



EMD - BATIMO

LIB ORLEANS - UDRP

OTTAWA

JUNE 12TH 2026 | 13521

NEUF 

FOTENN

emo batimo

TABLE OF CONTENTS

1 INTRODUCTION

SITE & REGIONAL CONTEXT	4
SUBJECT PROPERTY - AERIAL VIEWS	5
TRANSIT	6
SITE PHOTOS	7
OFFICIAL PLAN - TRANSECT & DESIGNATION	8-10
ORLÉANS CORRIDOR SECONDARY PLAN	11-12
CURRENT ZONING BY-LAW	13
DRAFT NEW ZONING BY-LAW	14
URBAN DESIGN GUIDELINES	15-16

2 PROPOSED DEVELOPMENT

PROJECT OVERVIEW	18
CONCEPT	19
PROJECT DEVELOPMENT	20-21
PERSPECTIVES	22-24
BUILDING TRANSITION	25
TECHNICAL SITE PLAN	26
PUBLIC REALM	27

3 PLANS AND SECTIONS

SITE PLAN	29-30
FLOOR PLANS - PARKING	31-32
FLOOR PLANS	33-38
SECTIONS	39-40

4 STATISTICS

STATISTICS	42-44
------------	-------

5 VIEWS

PRECEDENTS	46
PEDESTRIAN VIEWS	47-48

6 ELEVATIONS AND MATERIALITY

ELEVATIONS	50-55
------------	-------

7 SUN STUDIES

SUN STUDIES	57-58
-------------	-------

8 APPROACH TO SUSTAINABILITY

APPROACH TO SUSTAINABILITY	60-61
----------------------------	-------

9 WIND STUDY, CIVIL AND LANDSCAPE

WIND STUDIES	63-66
CIVIL	67-73
PROPOSED LANDSCAPE PLAN	74

A APPENDIX

BOUNDARIES OF THE AREAS	76
SCHEDULE 1A	77
ZONING PLAN	78
ZONING GRID - MC	79
ZONING GRID - H2	80
SURVEYOR PLAN	81-83
PROPOSED BLOCK PLAN	84-85
PROPOSED SITE PLAN	86
PROPOSED PHASING PLAN	87
RESPONSES TO PRE-CONSULTATION COMMENTS	88

1

INTRODUCTION

SITE & REGIONAL CONTEXT



SUBJECT PROPERTY - AERIAL VIEWS

- 1 St. Matthew High School
- 2 Orleans Wood Elementary School
- 3 Décarie Park
- 4 François Dupont Park
- 5 Divine Infant Elementary School
- 6 Marsha Park
- 7 Joe Jamieson Park
- 8 Pierre Rocque Baseball Field
- 9 No Frills Grocery store
- 10 Place d'Orléans Mall
- 11 Hotel Holiday Inn
- 12 Farm Boy Grocery store



Google Earth
Image Licensed: © 2023



SITE PHOTOS

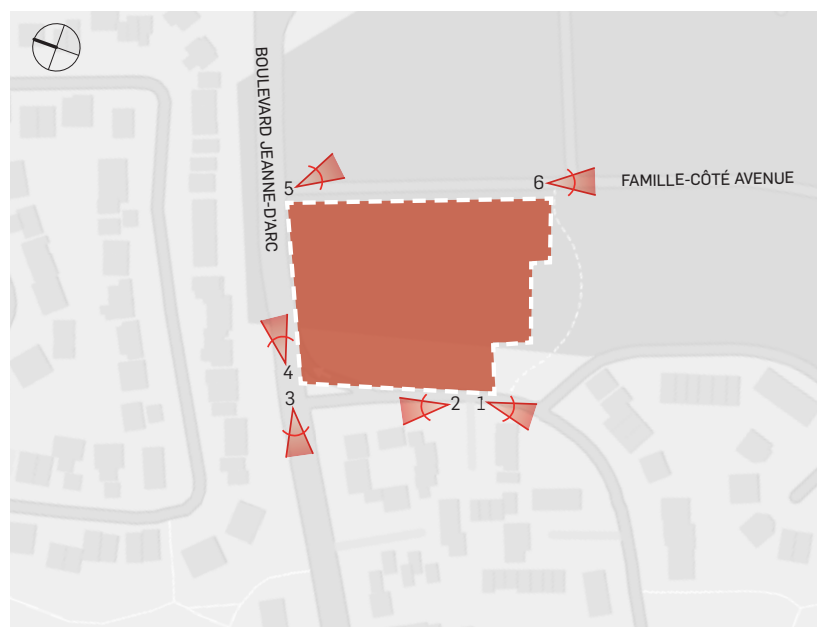
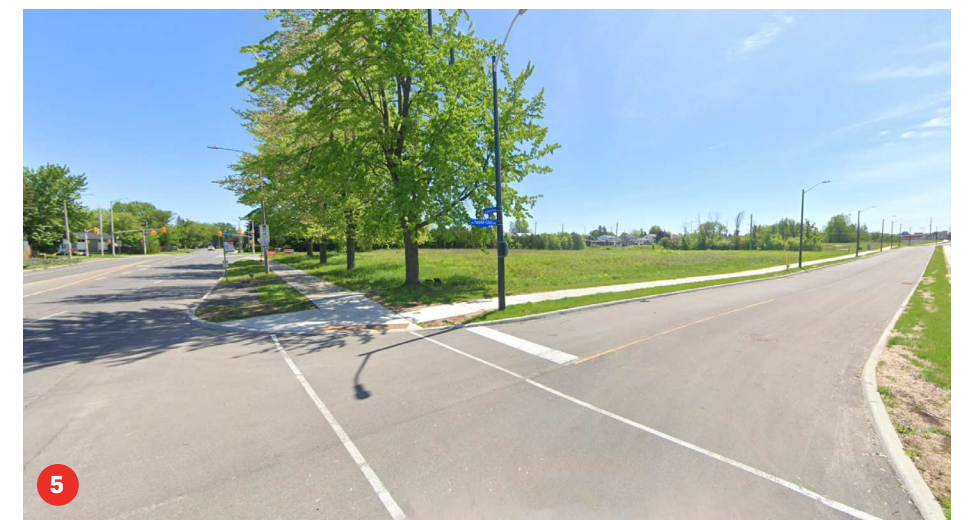

OFFICIAL PLAN -TRANSECT & DESIGNATION

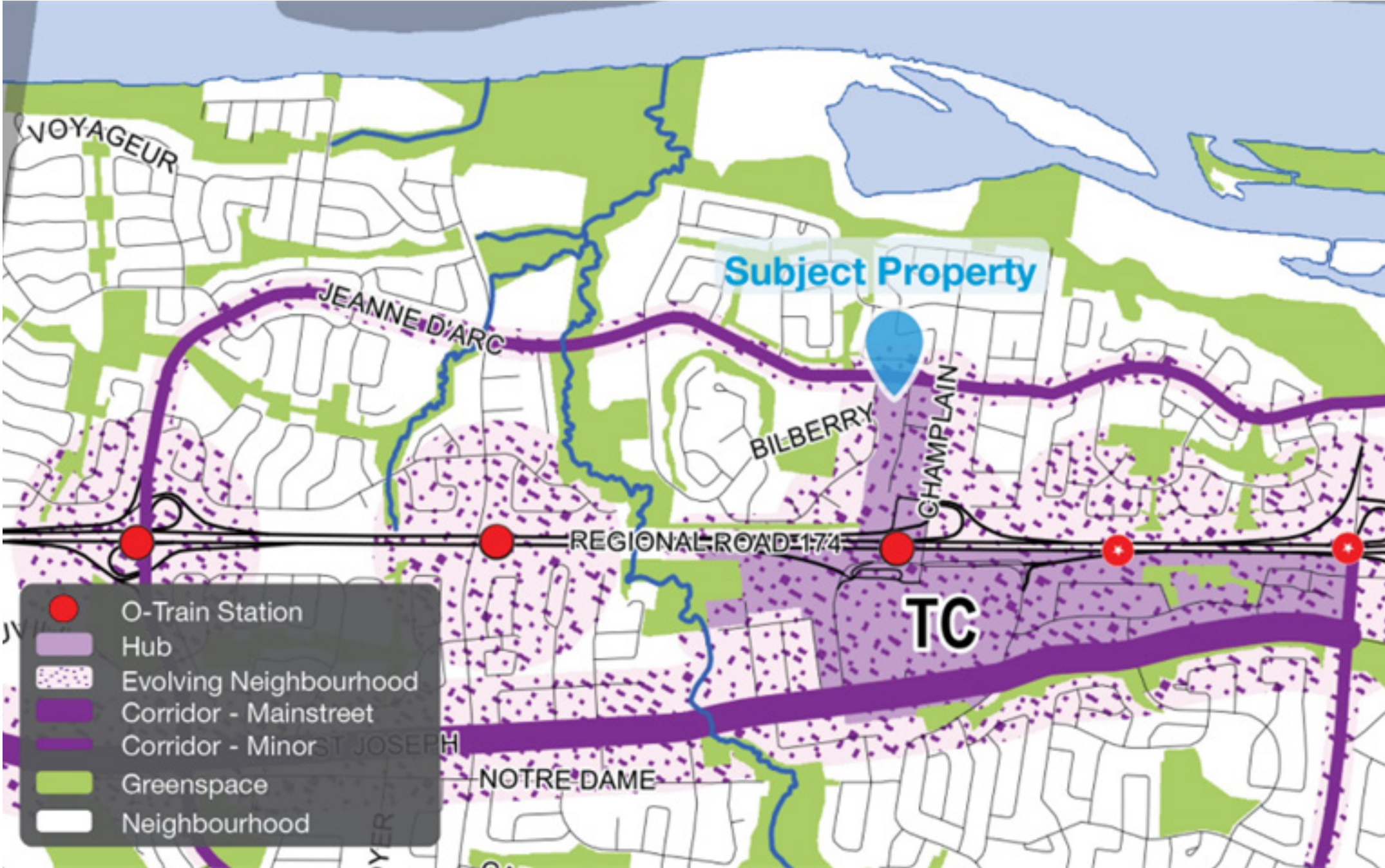

The subject property is designated **Hub** within the **Suburban (East) Transect** in the City of Ottawa Official Plan. Hubs are intended to support a mix of multi-unit dwellings and housing types.

High-rise building heights **up to 40 storeys** are permitted in Hubs within the Suburban Transect, generally within 400 metres of a rapid transit station.

Mid-rise building heights up to **9 storeys** are generally permitted within 800 metres of a rapid transit station.

OFFICIAL PLAN -PMTSA

The site is approximately 400 metres from the future Place d'Orléans O-Train station, within a **Protected Major Transit Station Area (PMTSA)**.

- Minimum density targets:
- People and Jobs per Gross Hectare: 120
 - Dwellings per Net Hectare: 150

- Minimum building heights:
- **4 storeys** within 400 metres walking distance of station.
 - **2 storeys** outside 400 metres walking distance of station.

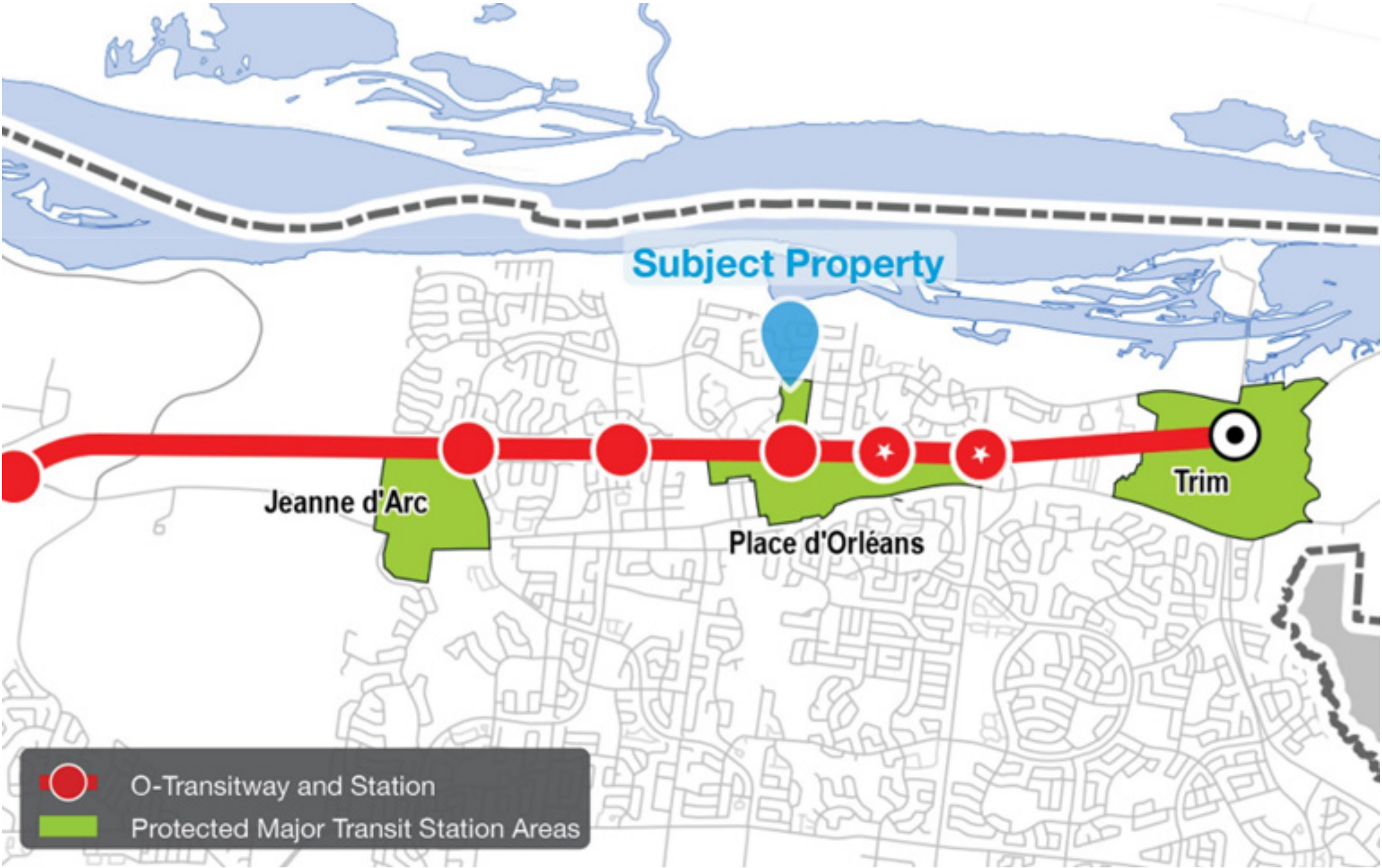

OFFICIAL PLAN -ROAD NETWORK



The subject property's location, with frontage along a **Major Collector** roads and proximity to **Highway 174**, provides efficient vehicular mobility.

Major Collector roads are intended to link smaller local roads with larger arterial roads, facilitation movement between communities and distributing traffic to main routes.

ORLÉANS CORRIDOR SECONDARY PLAN

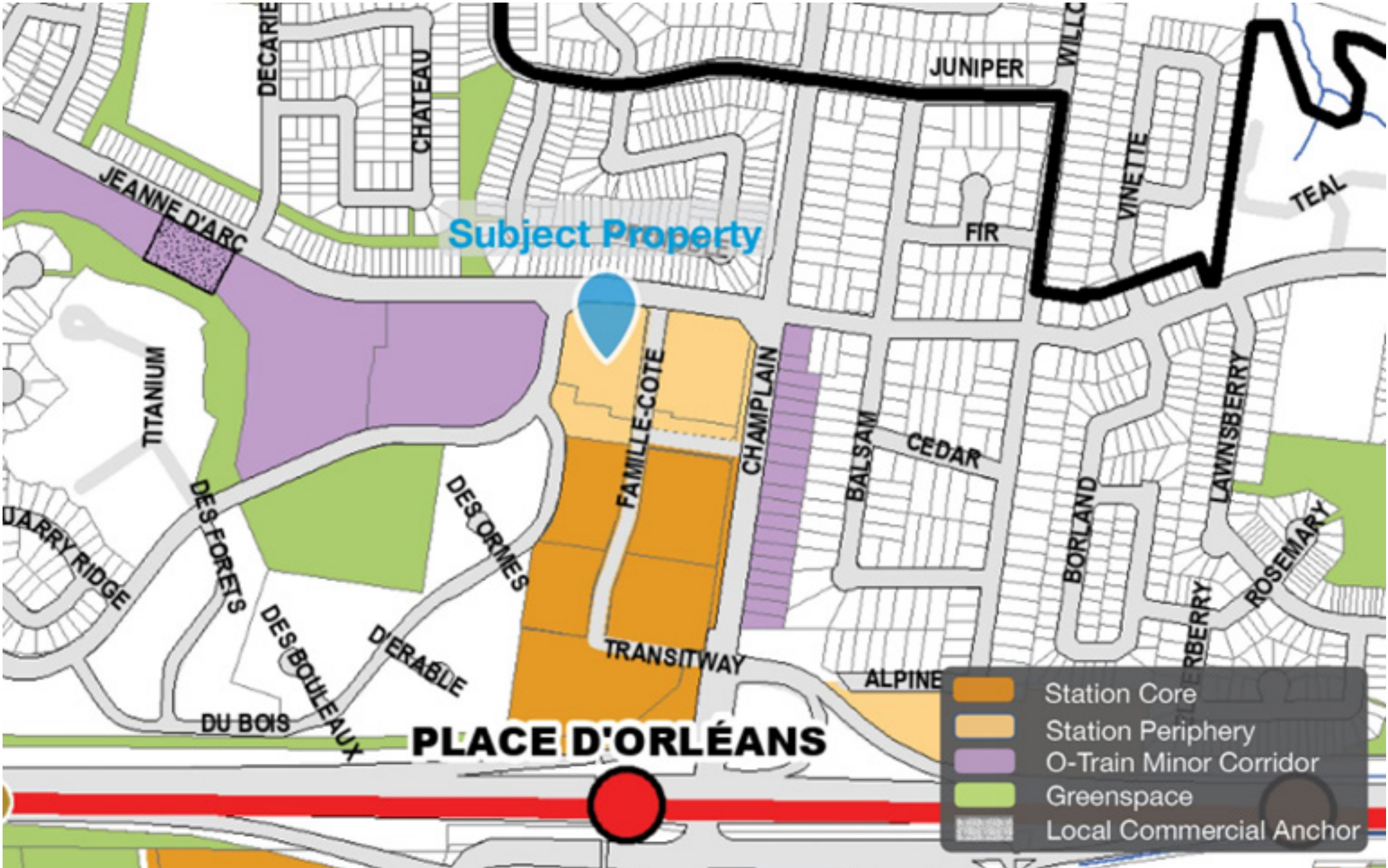

The subject property is designated **Station Periphery** and has a maximum permitted building height of **25 storeys**.

New development in the Station Periphery will be primarily mid-rise residential, with opportunities for high-rise, including the subject property.

Built-form transition to adjacent low-rise Neighbourhoods required.

ORLÉANS CORRIDOR SECONDARY PLAN

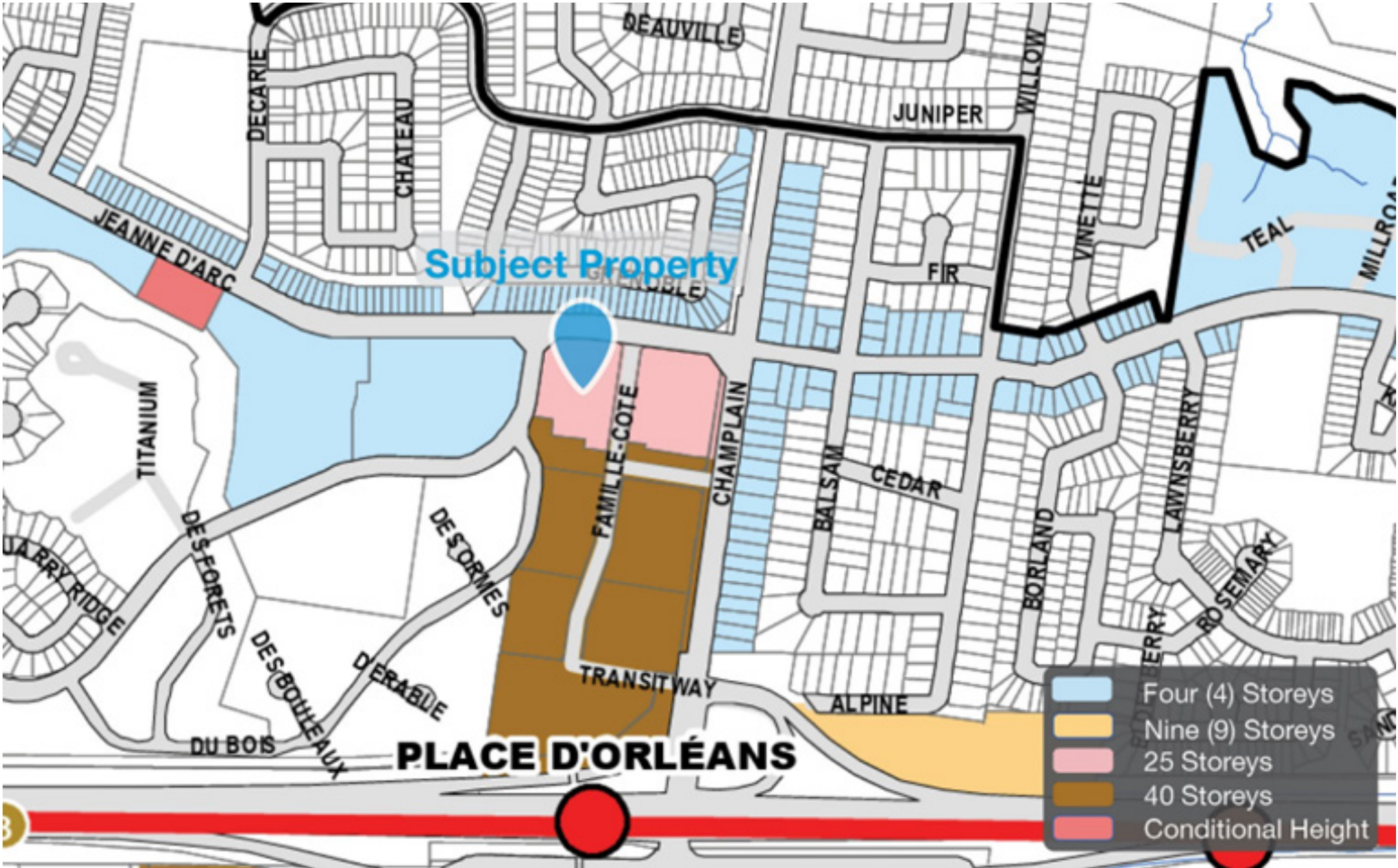

The subject property is identified for development of up to **25 storeys**.

High-rise buildings must provide height transitions, through setbacks and stepbacks generally guided by the application of an angular plane.

High-rise buildings must provide:

- Podium heights of 3-6 storeys.

- Minimized shadow impacts on public spaces.

- Tower separation of at least 25 meters (reduced to 23 meters if site constraints would result in the loss of a tower due to provision of this setback).

CURRENT ZONING BY-LAW



- The subject property is zoned **MC - Mixed-Use Centre Zone** in the current Zoning By-law.

Mixed, transit-supportive uses (offices, schools, retail, services, **high-density residential**, etc.)

- **Apartment dwelling, high rise** is a permitted use

- **Urban Exception [2179]:**

Min. 4 storeys for residential on any lot >600m²

DRAFT NEW ZONING BY-LAW

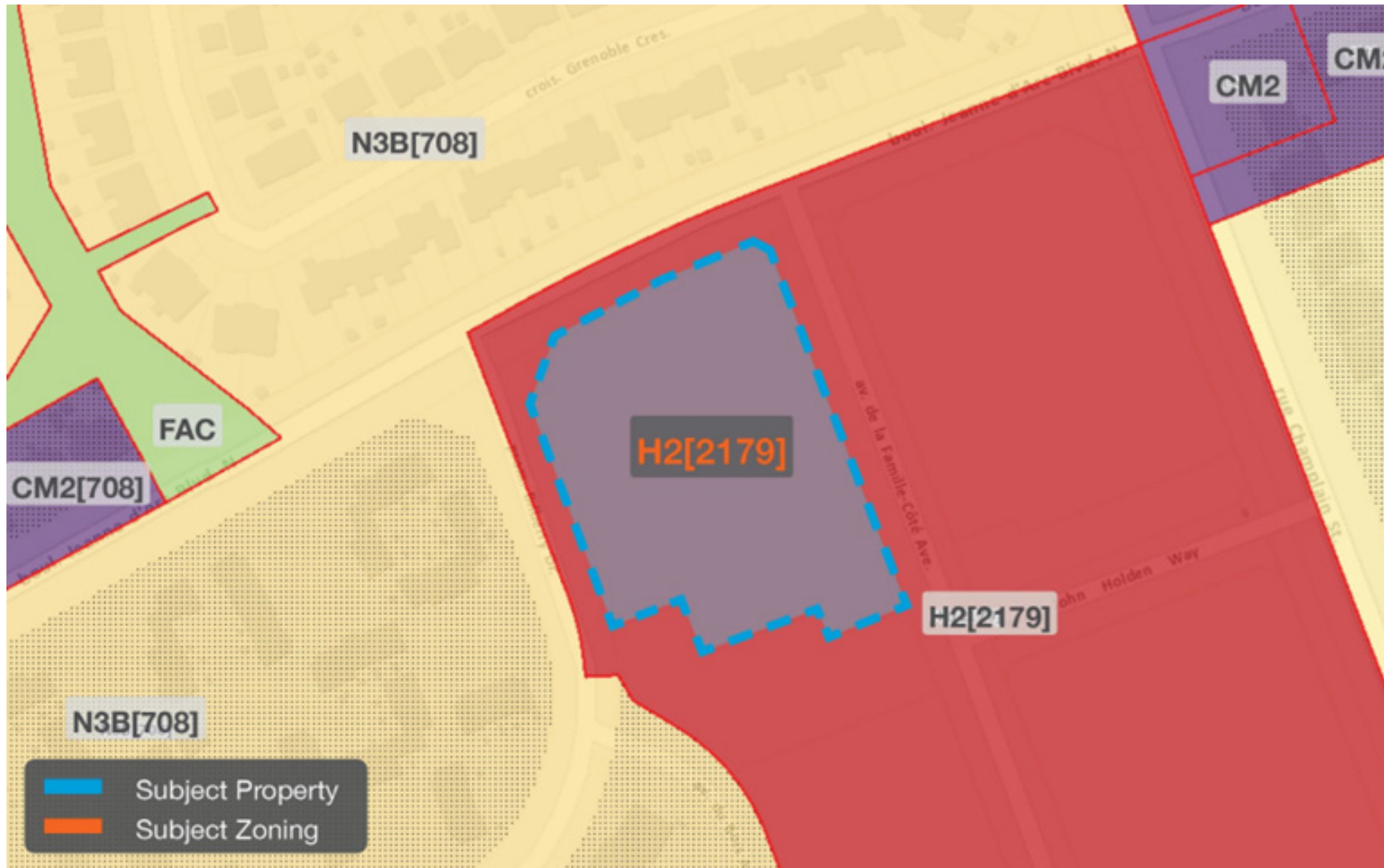

- The subject property is zoned **H2 - Hub Zone 2** in the draft new Zoning By-law.

Mixed, transit-supportive uses (offices, schools, retail, services, high-density residential, etc.)

- **Dwelling unit** is a permitted use

- **Urban Exception [2179]:**

Min. 4 storeys for residential on any lot >600m²

URBAN DESIGN GUIDELINES FOR HIGH-RISE BUILDINGS

The City of Ottawa's Urban Design Guidelines for High-Rise Buildings provide direction on Urban Design to be used during the review of development proposals.

Key guidelines reviewed include:

The application of a 45° angular plane

Small tower floorplate to minimize shadow and wind impacts

Base-Middle-Top approach



URBAN DESIGN GUIDELINES FOR TRANSIT ORIENTED DEVELOPMENT

These guidelines apply to development within a 600-metre walking distance of a rapid transit station and provide guidance for the proper development of strategically located properties.

Key guidelines reviewed include:

Step back buildings higher than 4 to 5 storeys to maintain a human scale along the sidewalk and reduce shadow and wind

Set large buildings back between 3-6 metres from the front/side property line to define the street edge and provide pedestrian space

Create transition in scale between higher development around transit and lower scale communities further away



AFTER

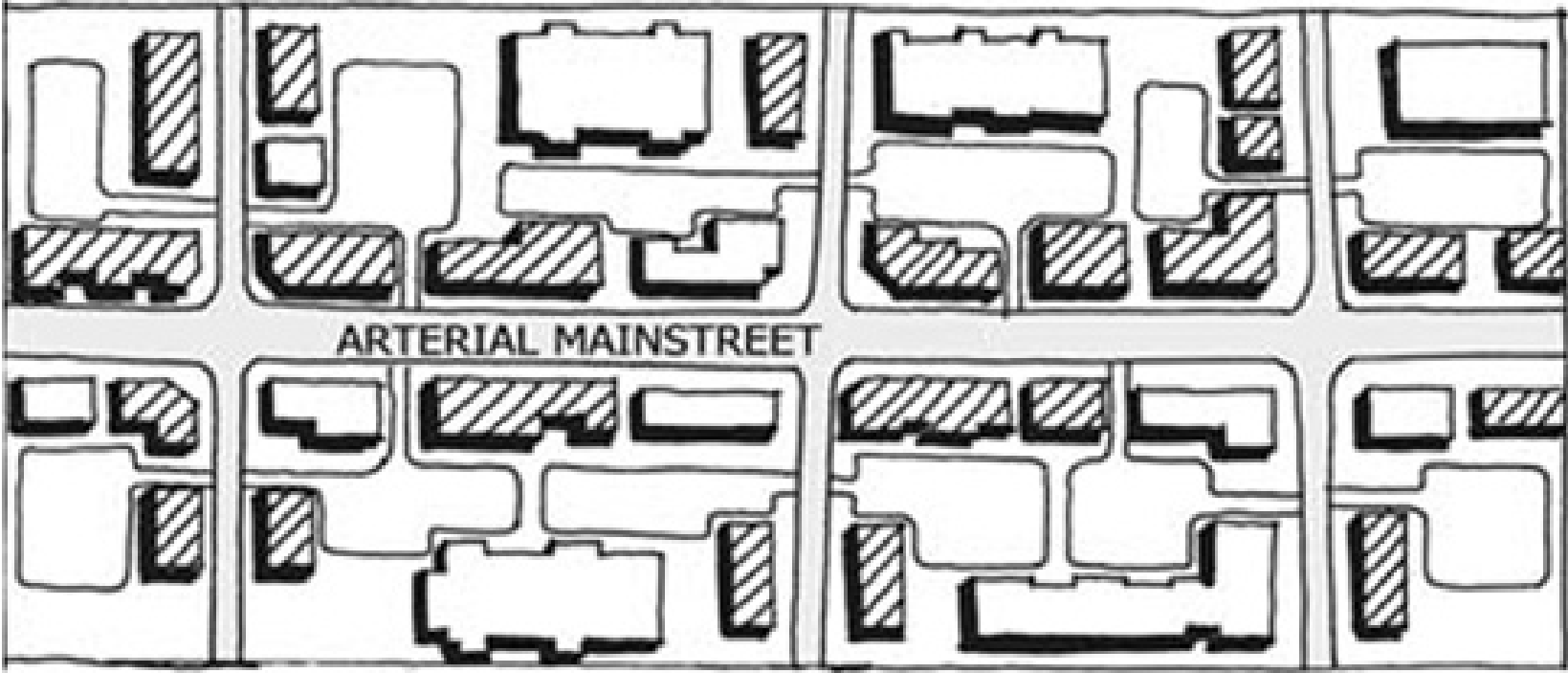

2

PROPOSED DEVELOPMENT

PROJECT OVERVIEW

2.0 PROJECT OVERVIEW

Site Plan Control (SPC) application to construct a residential building with a 12-storey tower (35 m) and a 14-storey tower (41 m), with a 4-storey podium.

No Official Plan or Zoning By-law Amendments required, as the proposal conforms and complies to all relevant policies and provision.

Total of 354 residential units

Phase 1: 226 units

Phase 2: 128 units

Total of 400 parking spaces (1.13 ratio)

379 underground

21 outdoor





AERIAL VIEW

2.1 CONCEPT

EMD-BATIMO is proposing a new residential development featuring two dynamic towers of **12 and 14 storeys**. Once completed, the project will offer **354 residential units**, contributing to the ongoing revitalization and urban densification around Place d'Orléans Station.

Accessibility & site integration

The development has been designed with ease of access in mind. Underground and surface parking are available via a dedicated ramp from Bilberry Drive. Residents can enter through welcoming lobbies located either along Avenue Famille-Côté or from the public landscaped courtyard. A convenient drop-off zone is strategically placed near the entrance to ensure smooth arrivals and departures.

Architectural Design

The towers feature a refined, neutral material palette that enhances visual interest while maintaining a timeless architectural expression. The podium, contrasting the towers, is thoughtfully designed to create a human-scaled experience, anchoring the towers and fostering a strong sense of place. A generous common area feature high-fenestration, creating active, well-lit spaces and a strong connection between the interior and exterior environments. It visually connects Famille-côté Avenue to the green park. Also, a semi-private rooftop terrace atop the podium gives residents additional high-quality outdoor living space.

Sustainability Features

The development considers a range of sustainable design features that contribute to making the building more efficient. Some of these features a 50% fenestration ratio which maximizes natural light exposure while working with a tight unit envelope to minimize energy loss; green roofs and lighter exterior colour palette designed to reduce the urban heat island effect, as well as energy efficient equipment.

PROJECT DEVELOPMENT

PRE-CONSULTATION MEETING

2025-01-08

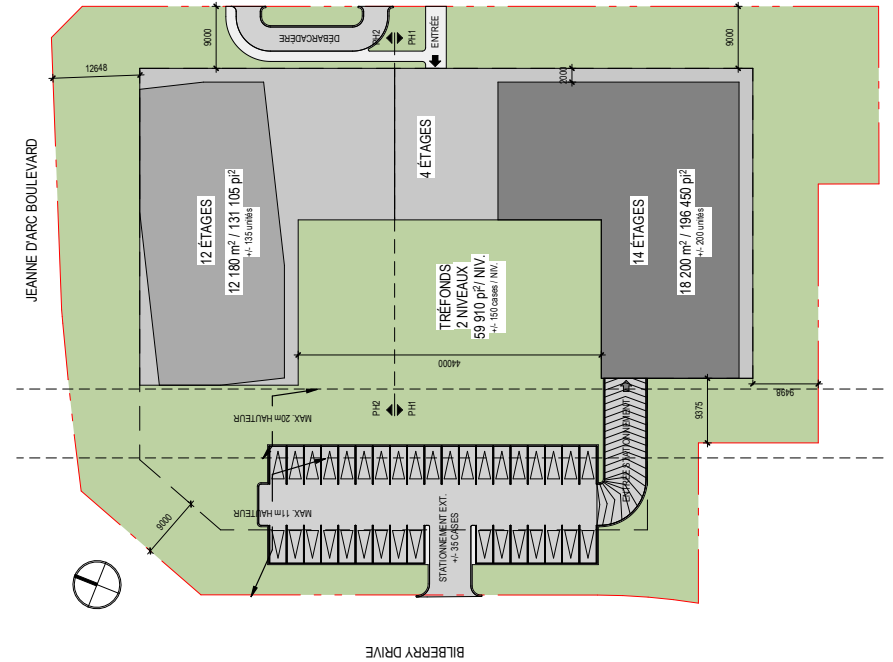

BUILDING HEIGHTS

Podium : 4 Storeys
 Tower A : 12 Storeys
 Tower B : 14 Storeys

UDRP

2025-09-22

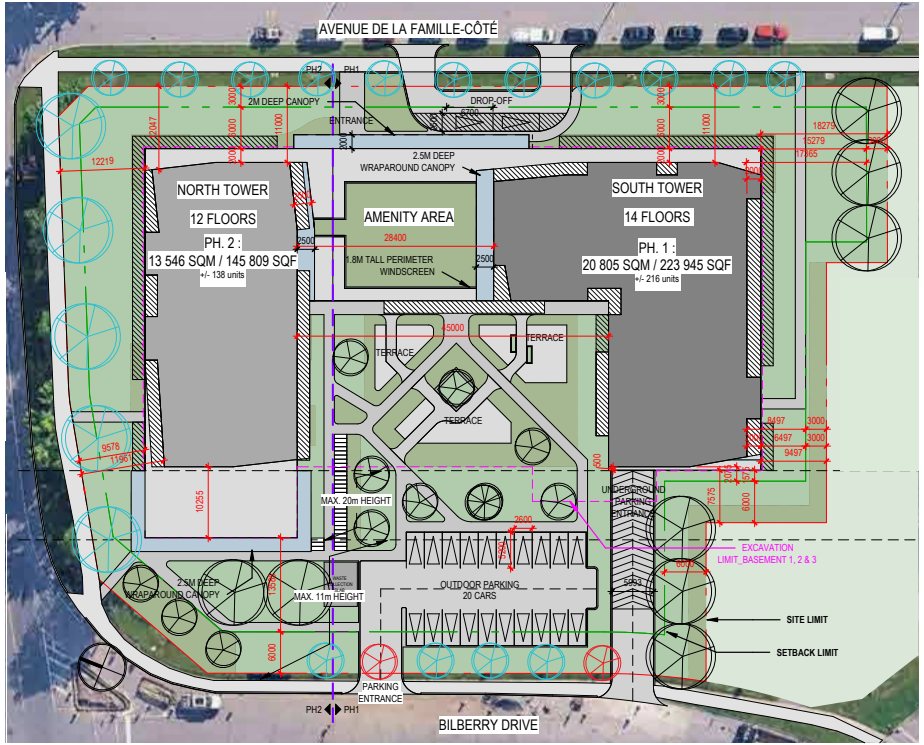

BUILDING HEIGHTS

Podium : 4 Storeys
 Tower A : 12 Storeys
 Tower B : 14 Storeys

ACTUAL DESIGN

2026-05-28

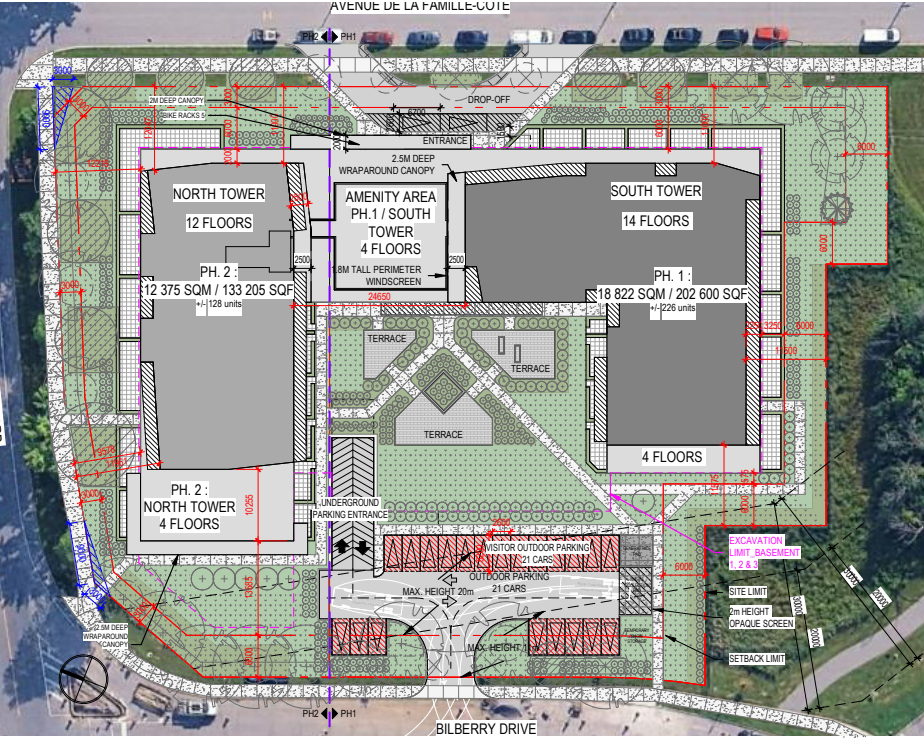

BUILDING HEIGHTS

Podium : 4 Storeys
 Tower A : 12 Storeys
 Tower B : 14 Storeys

Proposed development

VIEWS

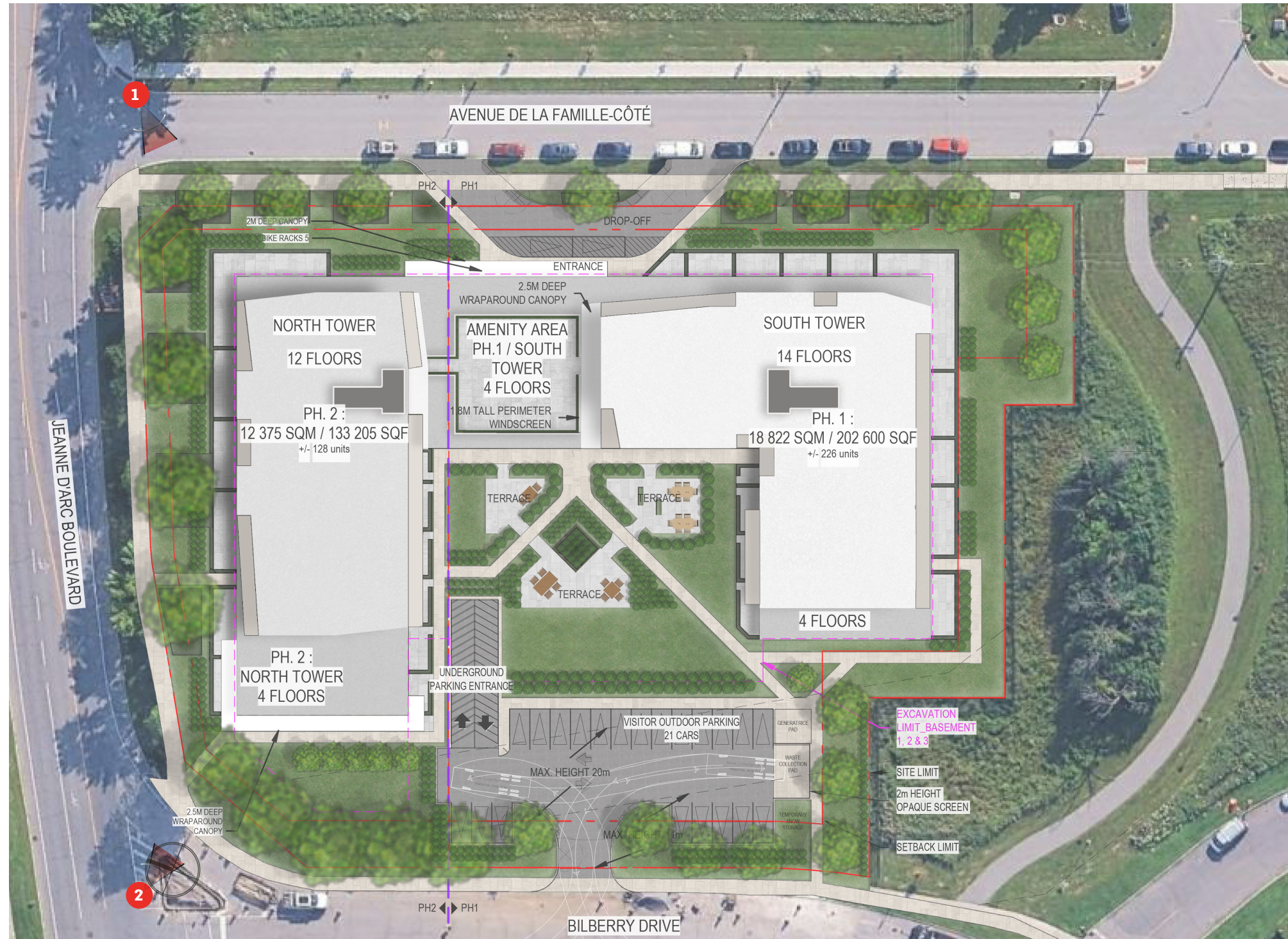

PROJECT DEVELOPMENT



500 Famille-Côté Avenue
ORLÉANS



Jeanne-d'Arc Boulevard
ORLÉANS

Proposed development

PERSPECTIVES - BUILDING HEIGHTS

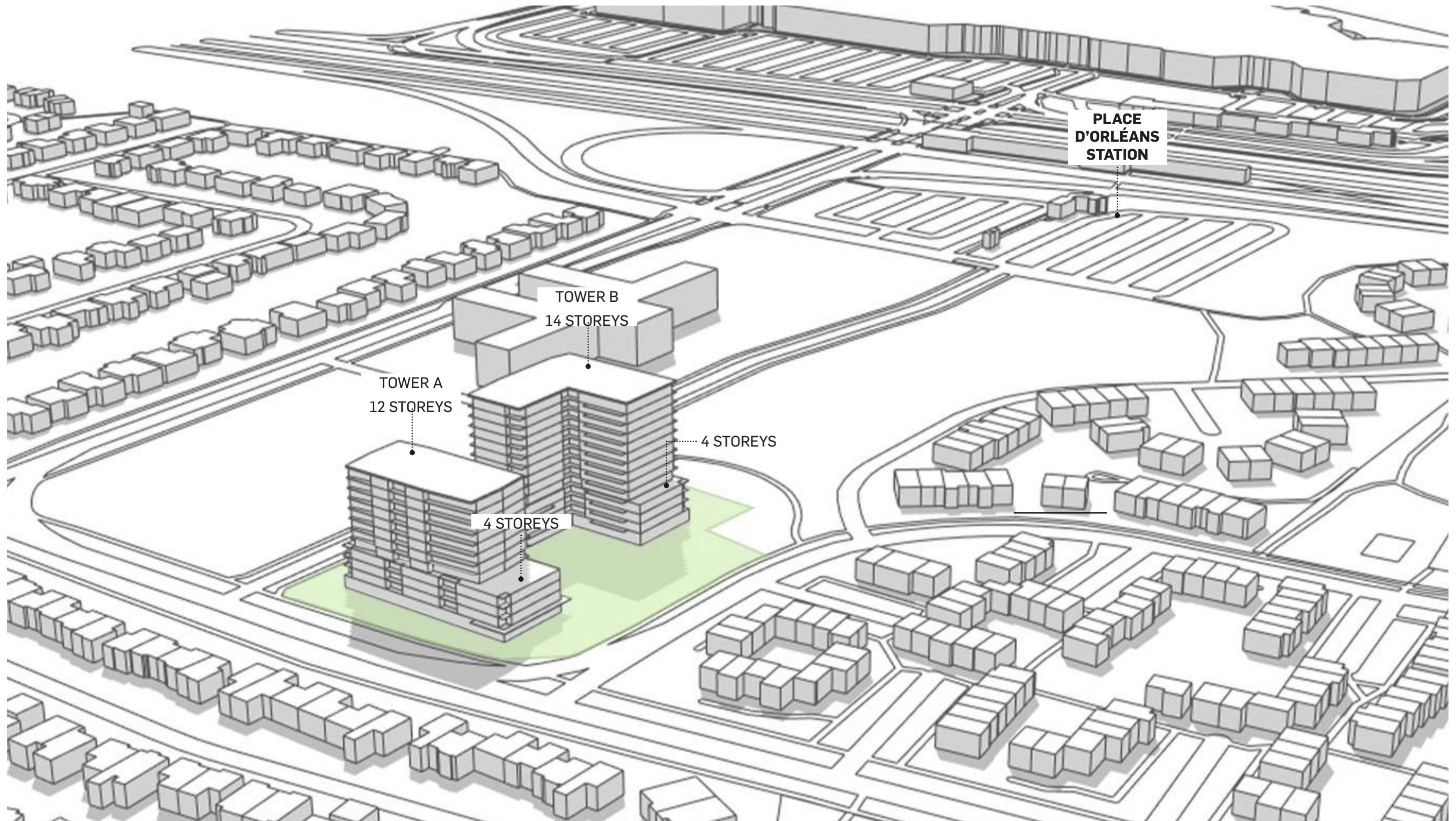

Proposed development

PERSPECTIVES - BIRDS EYE VIEW 01

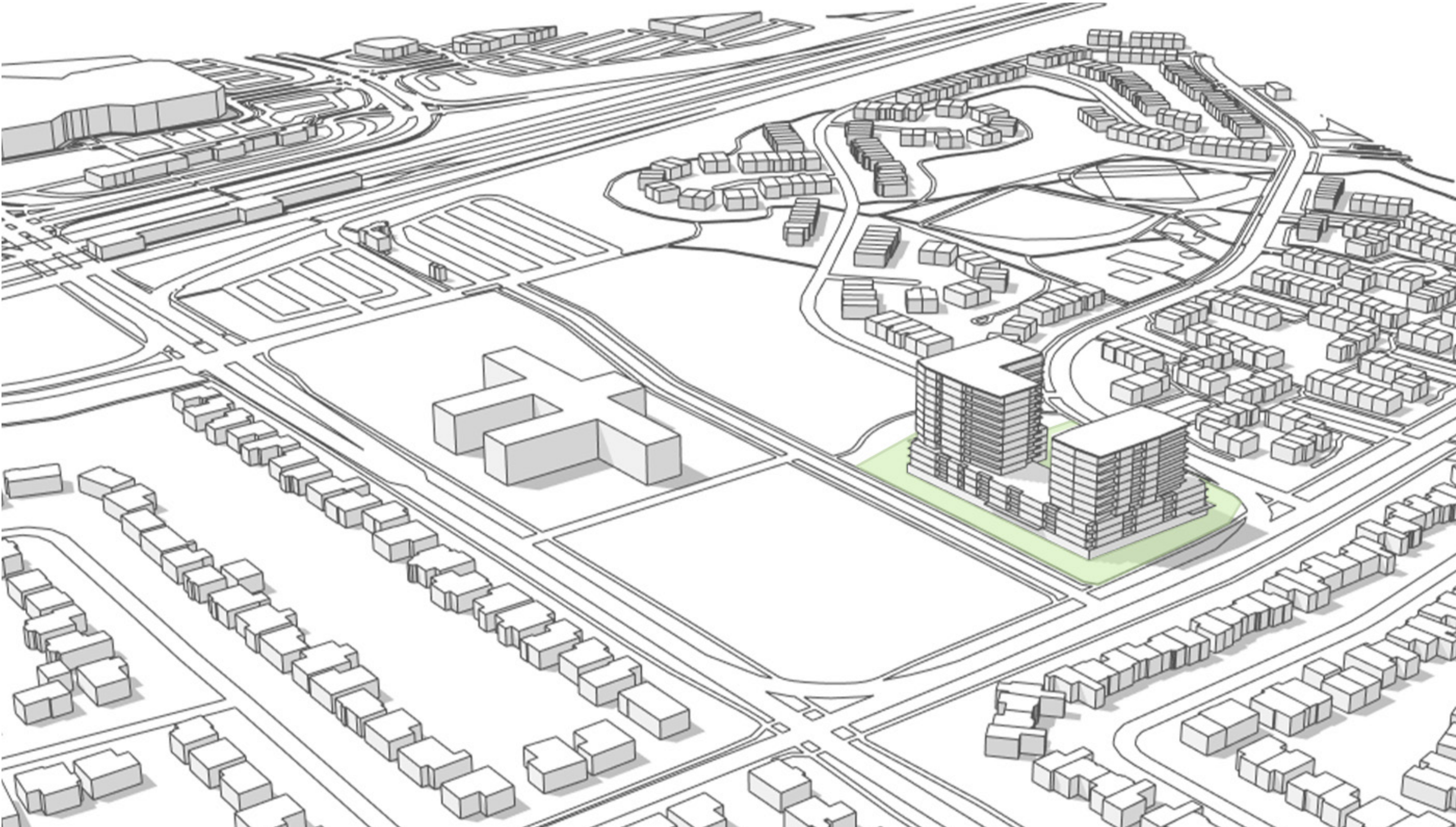

Proposed development

PERSPECTIVES - BIRDS EYE VIEW 02



Proposed development

BUILDING TRANSITION

2.3 BUILDING TRANSITION

The proposed development considers its surrounding site context to develop a site design that locates building typologies that relate to its existing and future context. While at present, the surrounding site context consists mostly of unifamilial houses, the development recognizes the sites location within a TOD area, its designation as a Hub and proximity to a rapid transit station (Suburban (East) Transect), where high-rise up to 25 storeys are contemplated as per the City of Ottawa Official Plan.

The proposed development achieves an appropriate transition to neighbouring properties which are currently characterized by low-rise residential uses and are anticipated to be developed into high-rise building heights as per the TOD plans. The development is designed to stepdown to neighbouring properties where the building heights are anticipated to be lower. Indeed, the 12 to 14 storeys towers break down the 25+ storeys towers located toward Queensway to provide a built-form transition to adjacent low-rise neighbourhoods.

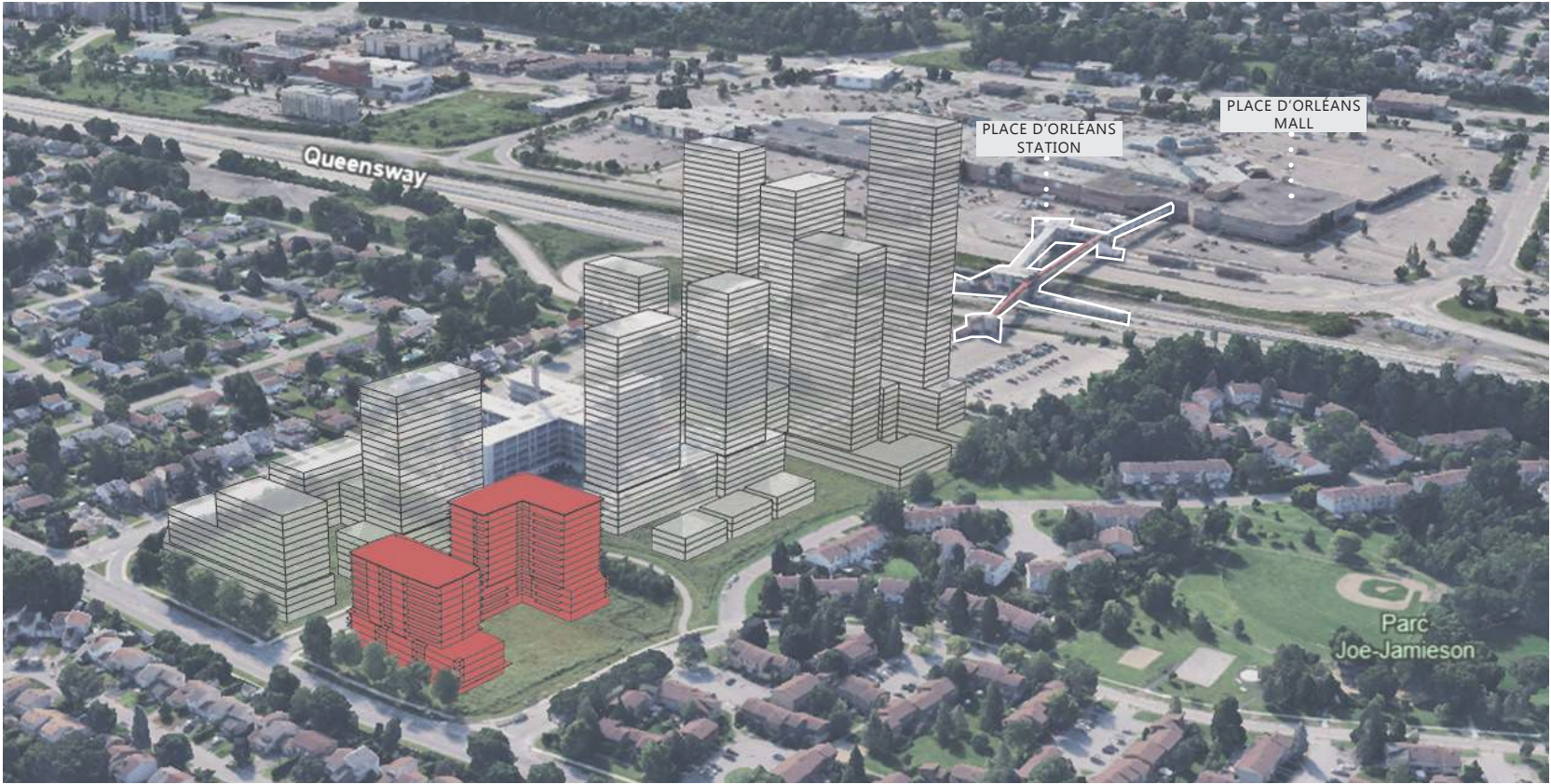

AREAL VIEW LOOKING TOWARDS EAST

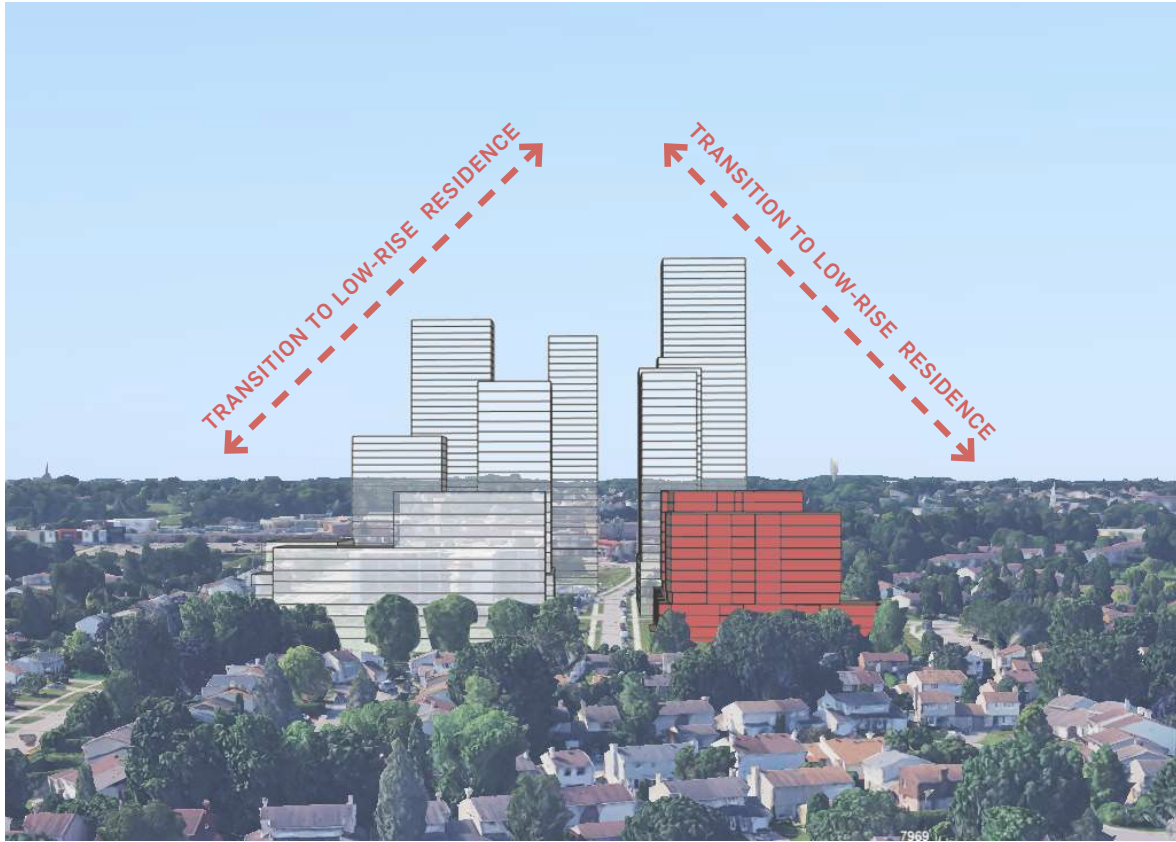

TECHNICAL SITE PLAN

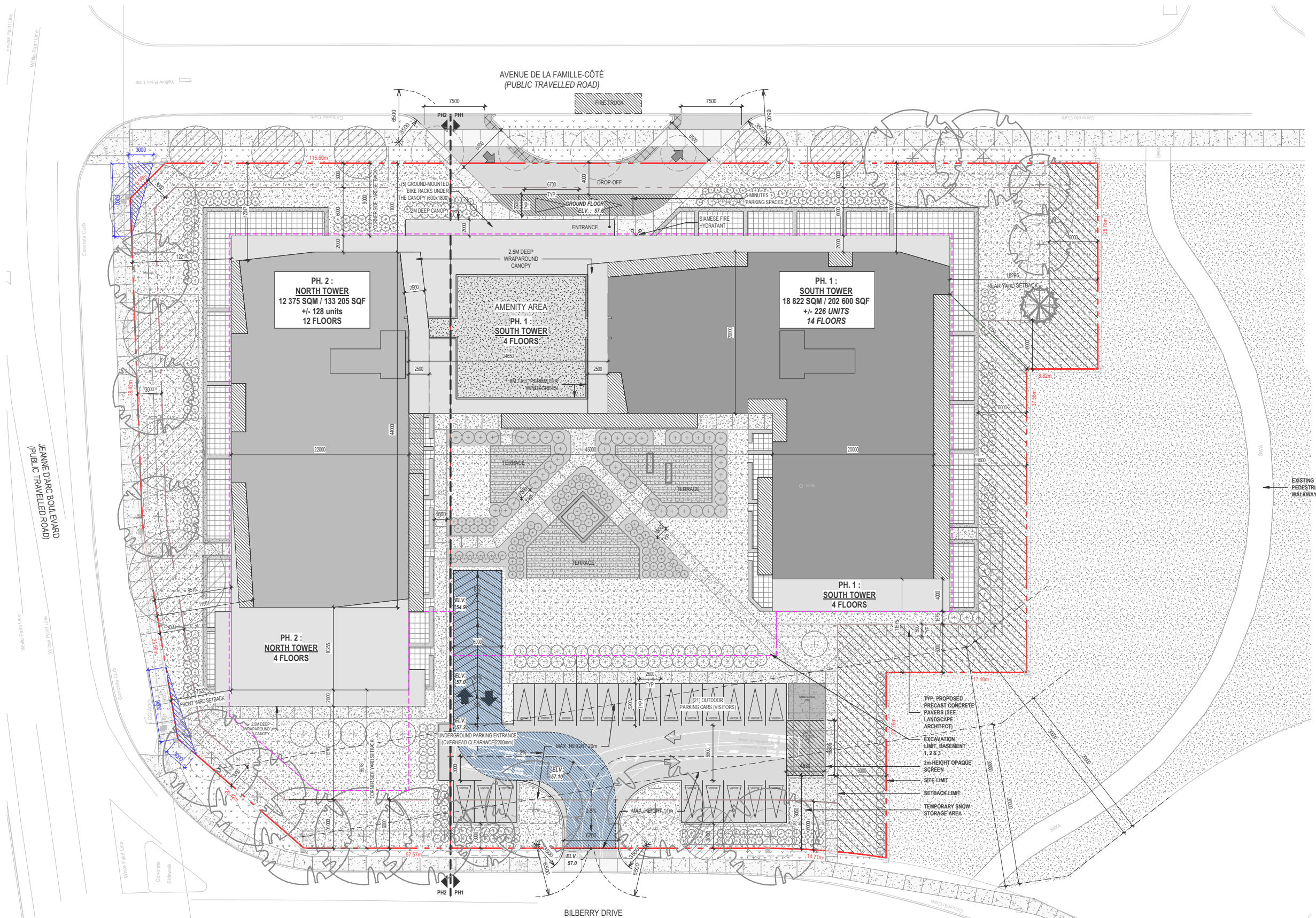

SITE INFORMATION	
SITE INFORMATION	
SITE AREA	8947 m ²
PHASE 1 - SOUTH TOWER	5 902 m ²
PHASE 2 - NORTH TOWER	3 045 m ²
HEIGHT	
PHASE 1 - SOUTH TOWER	45.547 m
PHASE 2 - NORTH TOWER	38.185 m
SETBACKS PROVIDED	
	NORTH SOUTH EAST WEST
DEVELOPMENT STATISTICS	
RESIDENTIAL UNITS	
Apartment phase 1	127
Apartment phase 2	128
Apartment total	255
GROSS LEASABLE FLOOR AREA # m²	
G/LFA phase 1	18 822 m ²
G/LFA phase 2	12 375 m ²
G/LFA total	31 197 m ²
PROPOSED GFA	
GFA phase 1	18 822 m ²
GFA phase 2	12 375 m ²
GFA total	31 197 m ²
TOTAL BUILDING AREA # m²	
Phase 1	25 191 m ²
Phase 2	17 856 m ²
Total building (basement incl.)	43 047 m ²
PARKING	
Phase 1	207
Phase 2	143
Total parking	350
Water waste (included)	36
Handicap waste Type A (included)	2
Handicap waste Type B (included)	4
Total handicap parking	100
AMENITY AREA	
ZONING BY-LAW SECTION 137	Required (m ²)
MINIMUM FOR APARTMENT COVERINGS: 6 m ² /UNIT	2 124
MINIMUM FOR COMMON AREAS: 1 m ² /UNIT	1 962
COMMON AMENITY - AREA - Area	3 121
GF Resident Common Interior Amenity Area	290
GF Resident Common Exterior Amenity Area	2 471
GF Pool Terrace	756
2nd to 3rd Floor - Private Balconies	256
4th Floor - Private Balconies	260
5th Floor - Common Terrace	260
6th to 14th Floor - Private Balconies	230
15th to 16th Floor - Private Balconies	230
17th to 18th Floor - Private Balconies	230
TOTAL AMENITY AREA	4 883
TOTAL PRIVATE AMENITY AREA	3 883
TOTAL COMMON AMENITY AREA	1 000
LOT COVERAGE	
Proposed 2nd area	8 927
Proposed building area	3 241
Proposed	36%
LANDSCAPED SURFACES	
Soil Retention	3 176
Soil Landscaping	1 516
Total landscaping	4 692
Proposed	87%
TOTAL BUILDING AREA	
PROPOSED RATIO	5.1

GRAPHIC LEGEND	
	SITE LIMIT (LENGTHS PROPERTY LINES)
	SETBACK LIMIT
	PHASING
	HEIGHT LIMIT
	UNDERGROUND PARKING LIMIT
	EASEMENT (SEE SURVEY)
	CORNER SIGHT TRIANGLES
	PROPOSED LAWN AREA (SEE LANDSCAPE ARCHITECT)
	PROPOSED PRECAST CONCRETE PAVERS (SEE LANDSCAPE ARCHITECT)
	PROPOSED PLANTING AREA (SEE LANDSCAPE ARCHITECT)
	PROPOSED CONCRETE PAVERS (SEE LANDSCAPE ARCHITECT)
	DRIVEWAY PATH (AVERAGE GRADIENT 5.3%)
	EXISTING TREE TO REMAIN (SEE LANDSCAPE ARCHITECT)
	EXISTING TREE TO BE REMOVED (SEE LANDSCAPE ARCHITECT)
	PROPOSED DECIDUOUS TREE (SEE LANDSCAPE ARCHITECT)
	PROPOSED CONIFEROUS TREE (SEE LANDSCAPE ARCHITECT)
	PROPOSED SHRUBS, PERENNIALS AND ORNAMENTAL GRASSES (SEE LANDSCAPE ARCHITECT)



2.4 PUBLIC REALM

Public Realm:

- Human scale to create comfortable and safe pedestrian realm throughout the site
- Prioritized Pedestrian comfort and scale
- Prioritized active frontages,
- Pedestrian Connections
- glazed building podiums that contribute to “eyes on the street” and animation
- building articulation and setbacks that define the pedestrian realm

3

PLANS AND SECTIONS

SITE PLAN

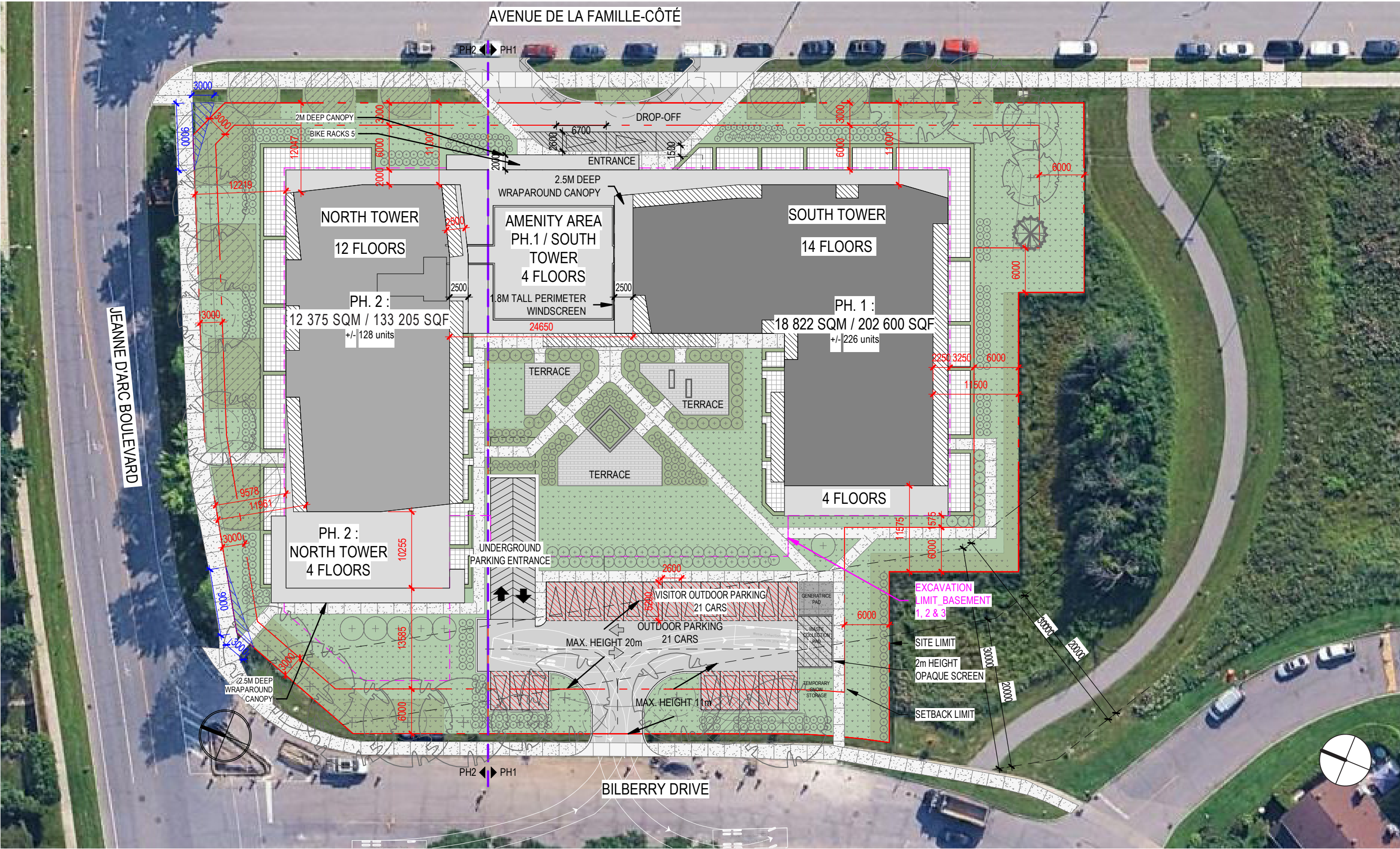

SITE PLAN

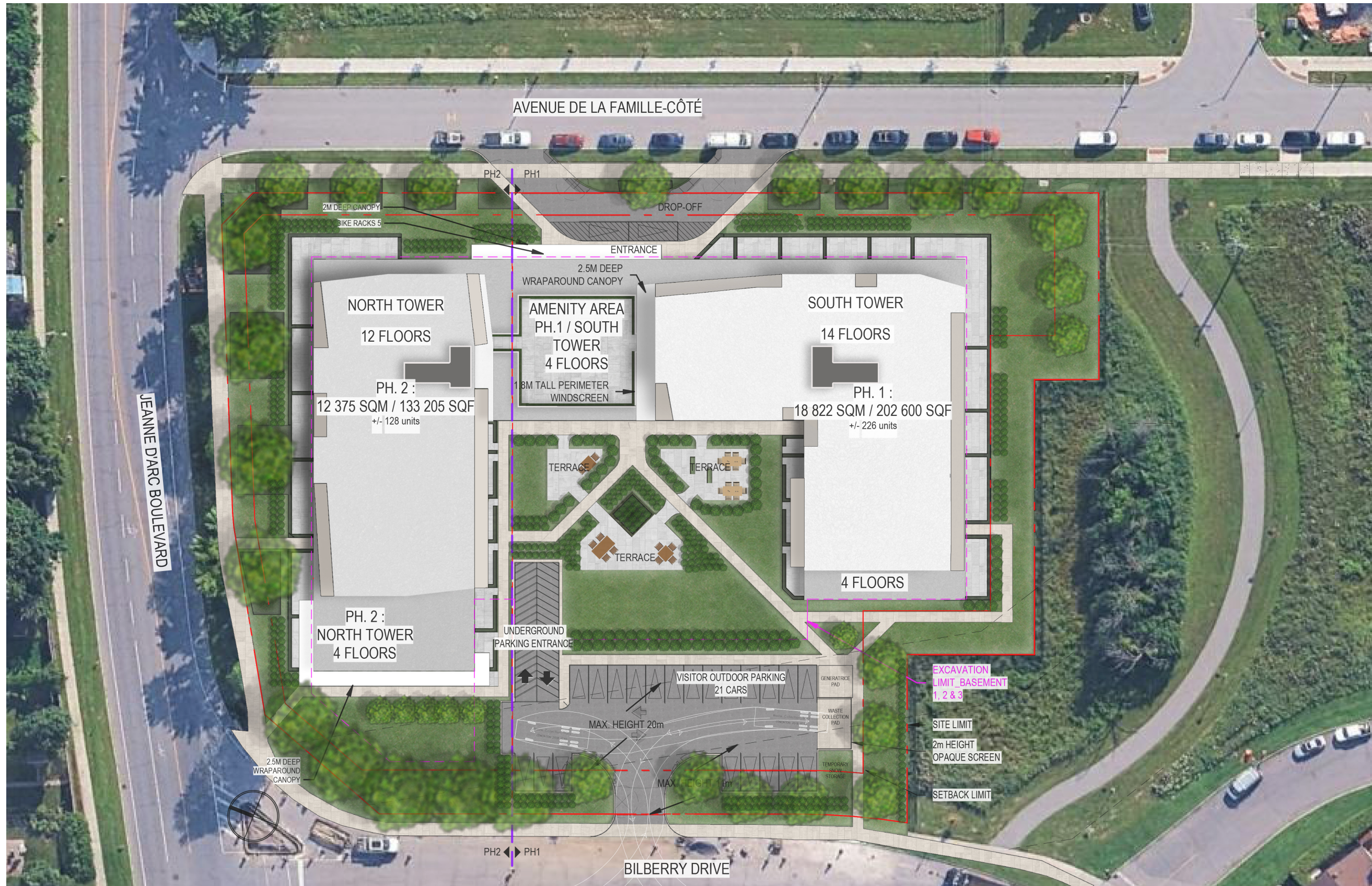

FLOOR PLANS

1:500

PARKING P2 & P3

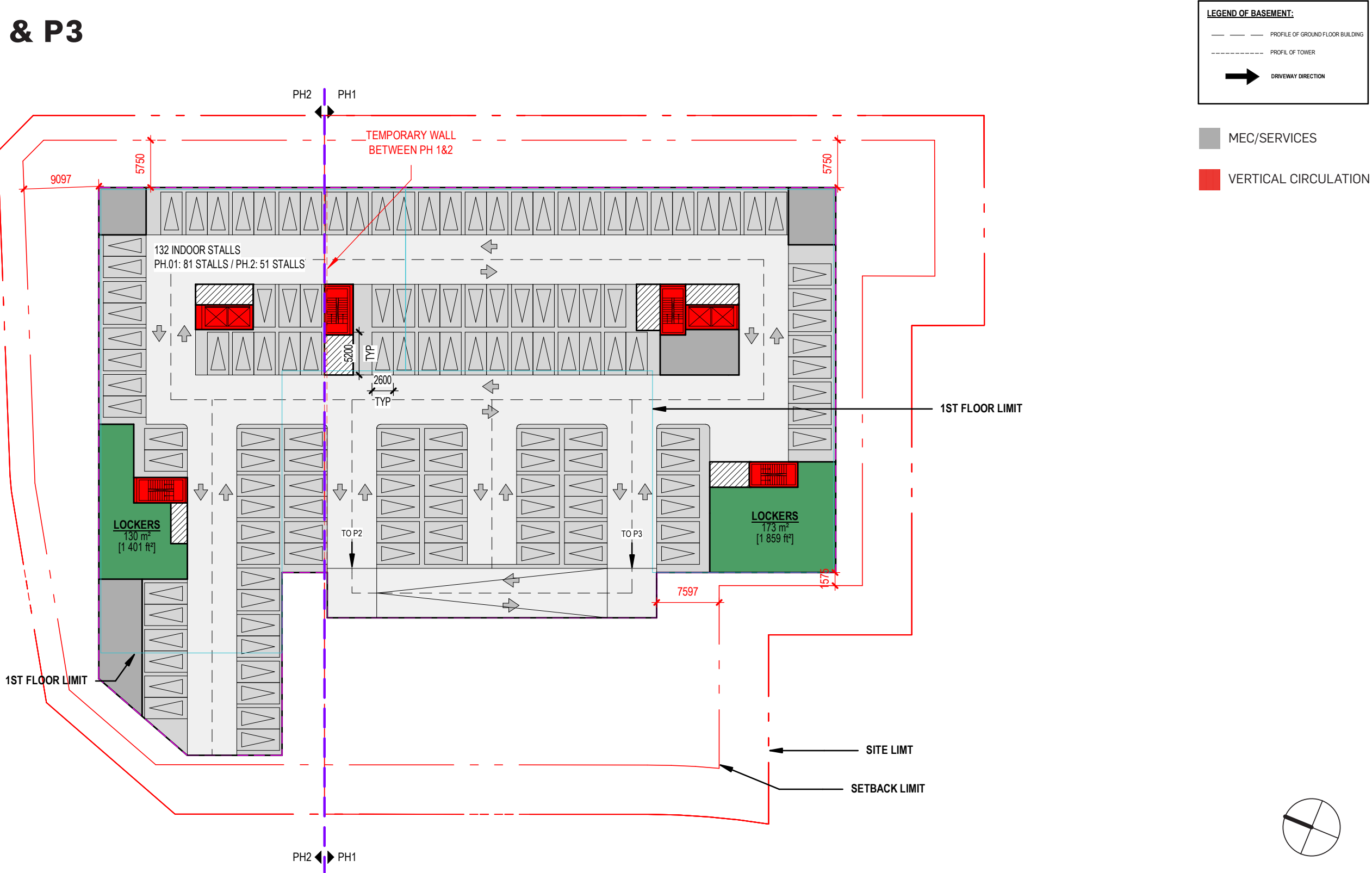

FLOOR PLANS

1:500

PARKING P1

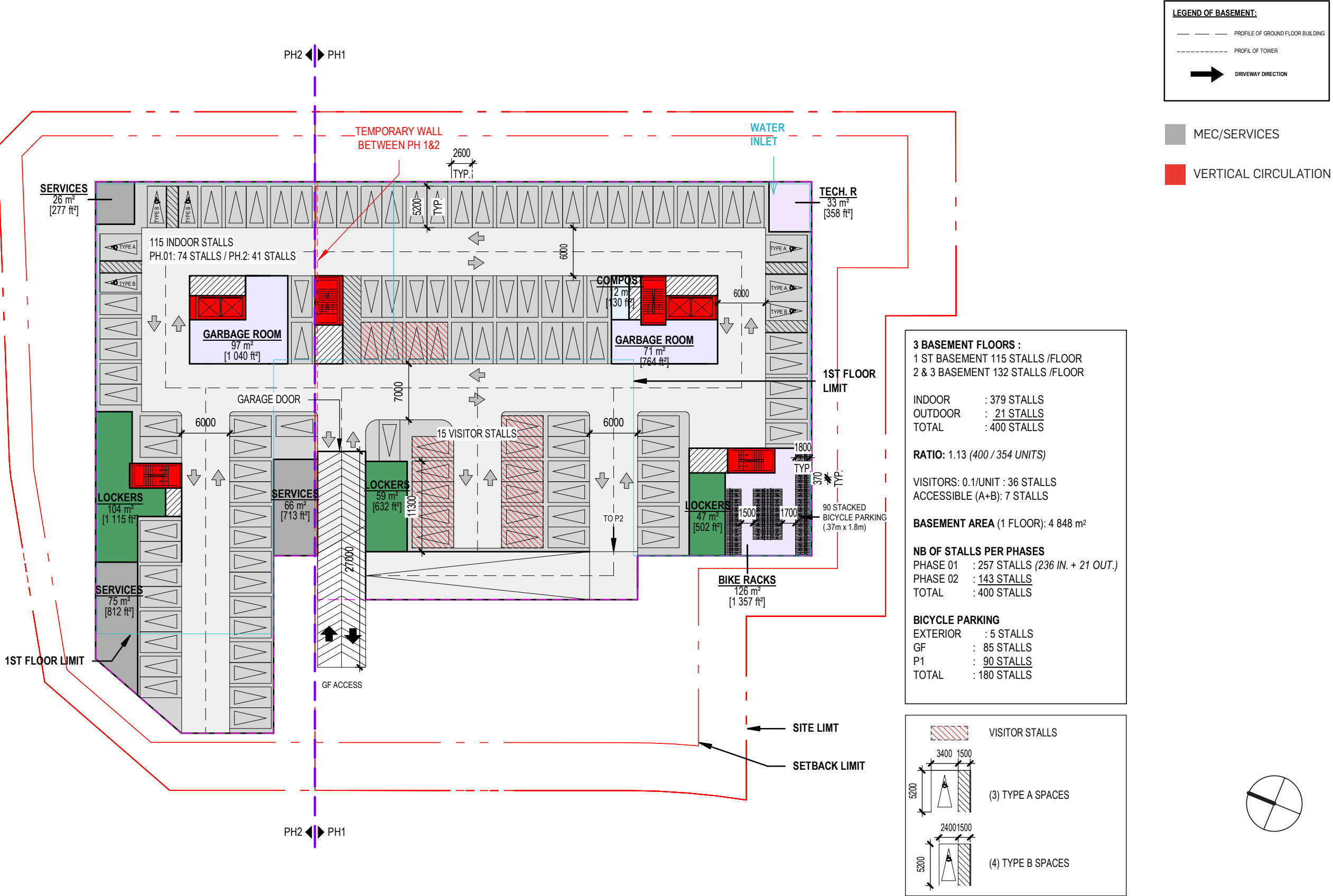

Plans & Sections

GROUND FLOOR

FLOOR PLANS

1:500

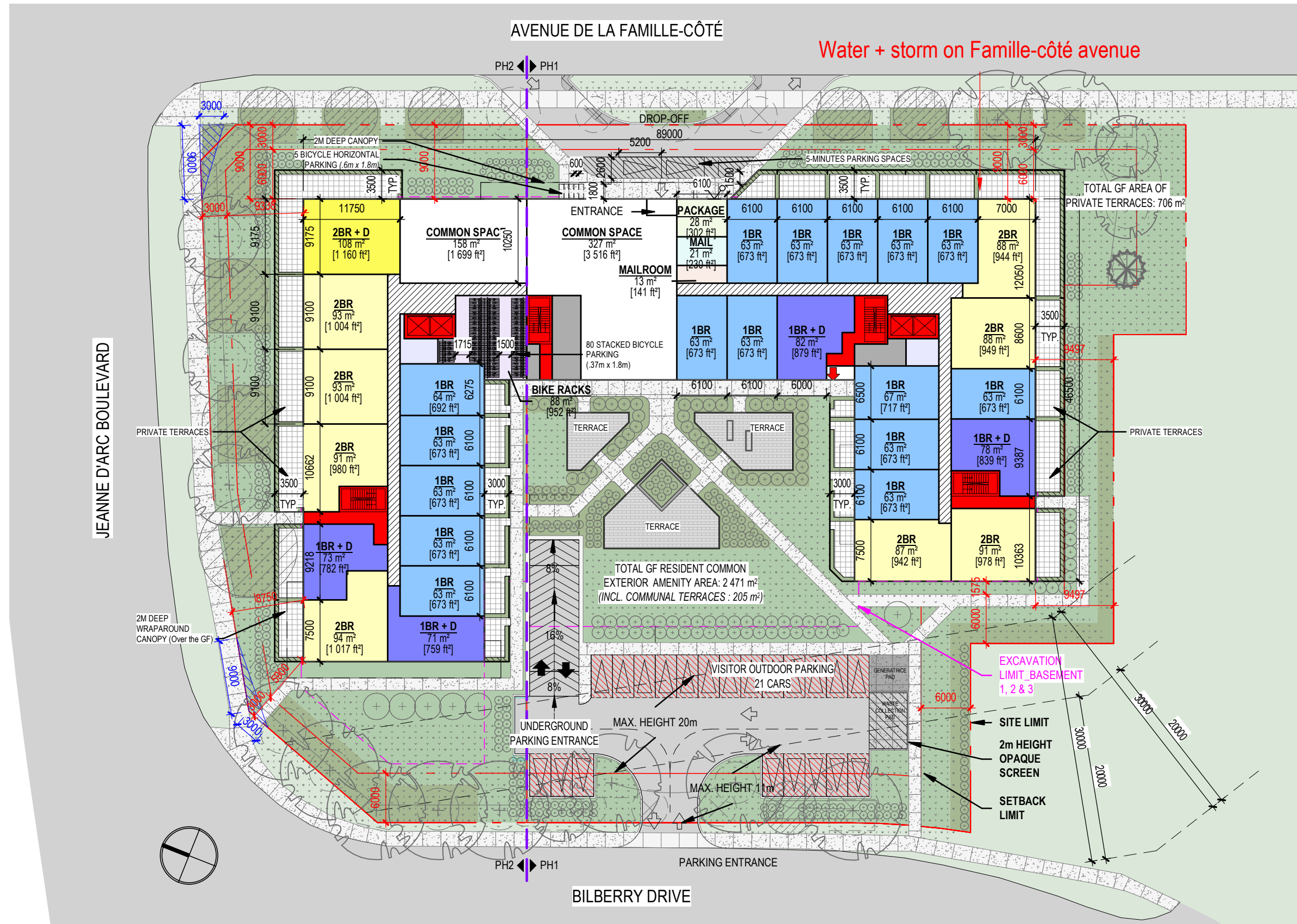

- 1 BEDROOM
- 1 BEDROOM + DEN
- 2 BEDROOMS
- 2 BEDROOMS + DEN
- 3 BEDROOMS
- VERTICAL CIRCULATION
- LOBBY/AMENITIES
- MEC/SERVICES



Plans & Sections

TYPICAL FLOOR PLAN - 4TH FLOOR

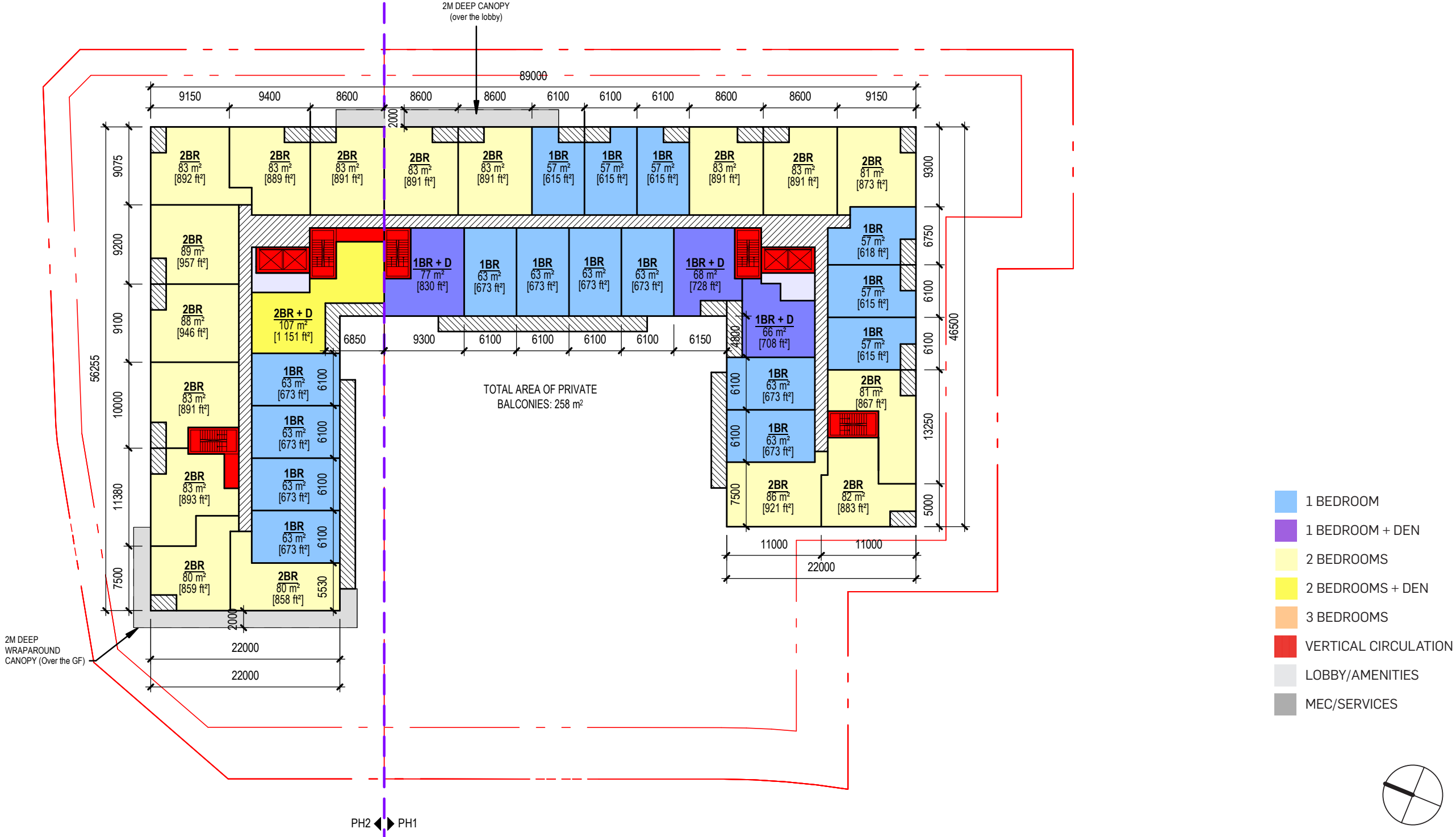

TYPICAL FLOOR PLAN - 5TH FLOOR

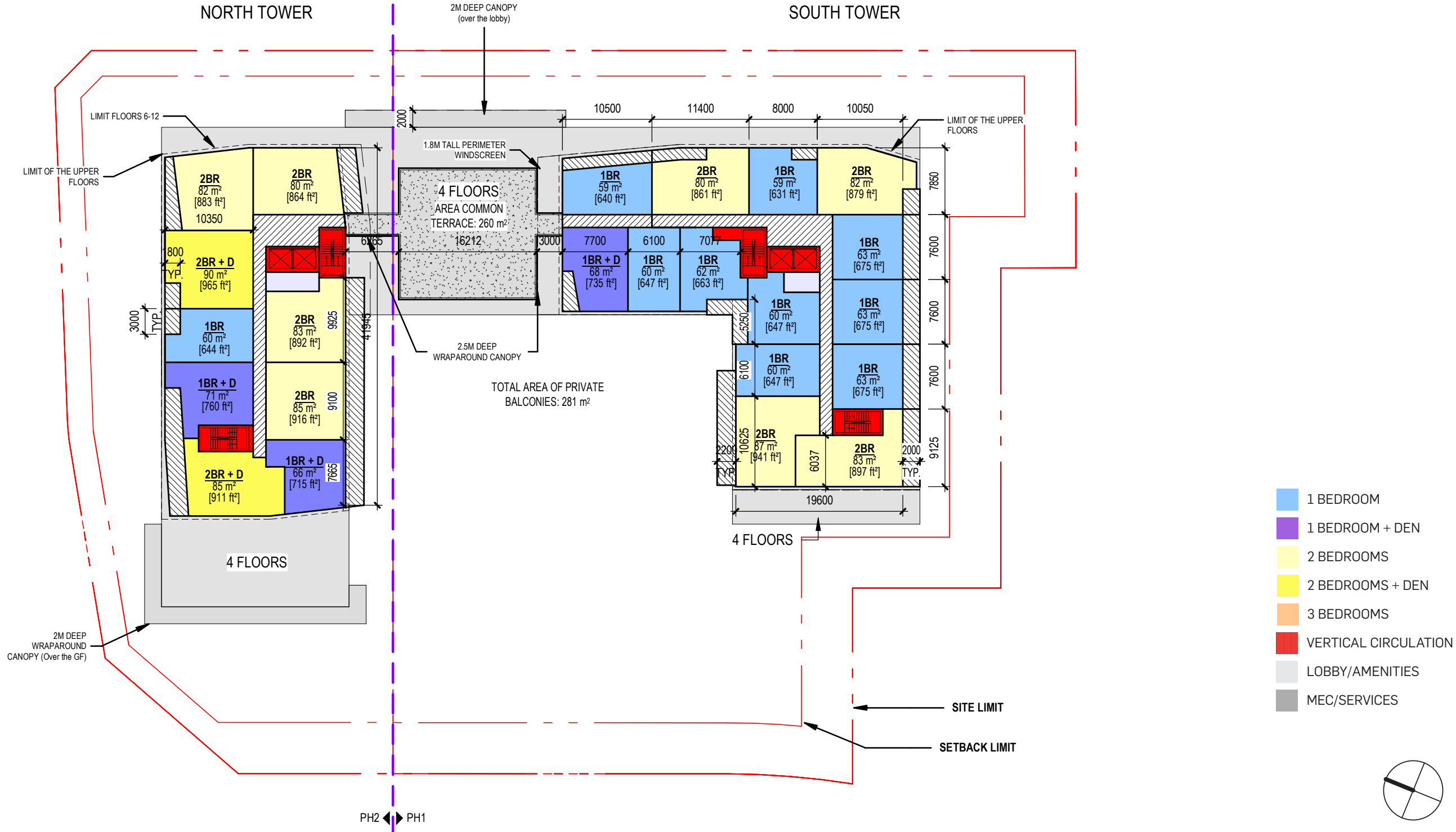

Plans & Sections

TYPICAL FLOOR PLAN - 13TH TO 14TH FLOOR

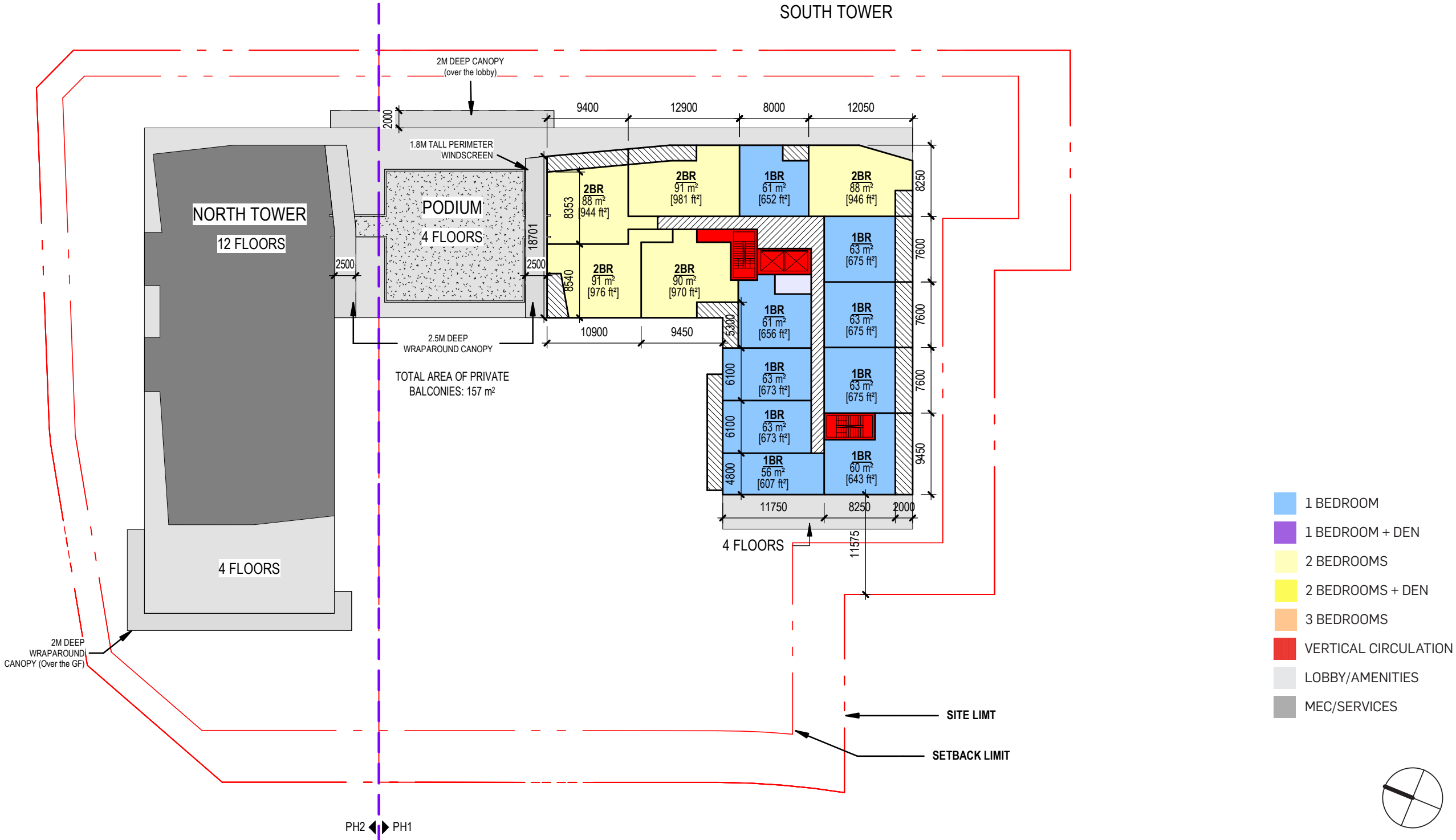

LONGITUDINAL SECTIONS

1:400

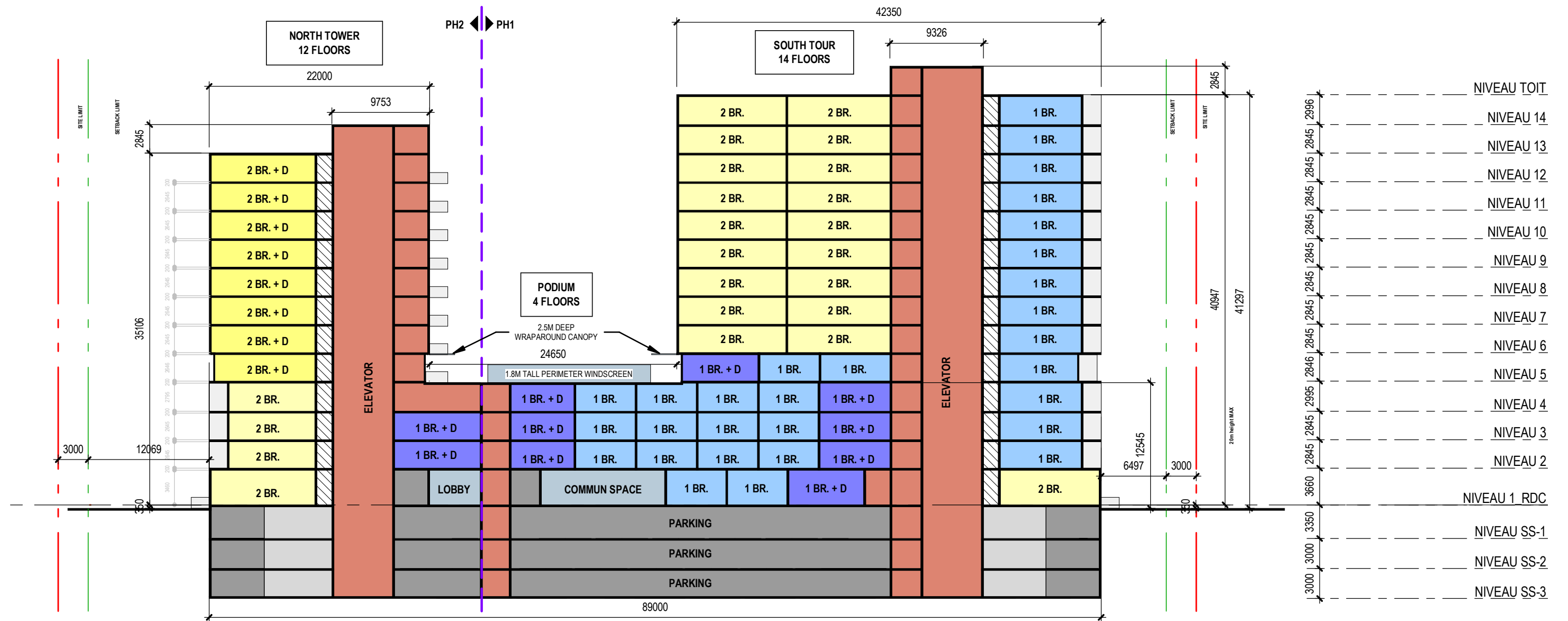
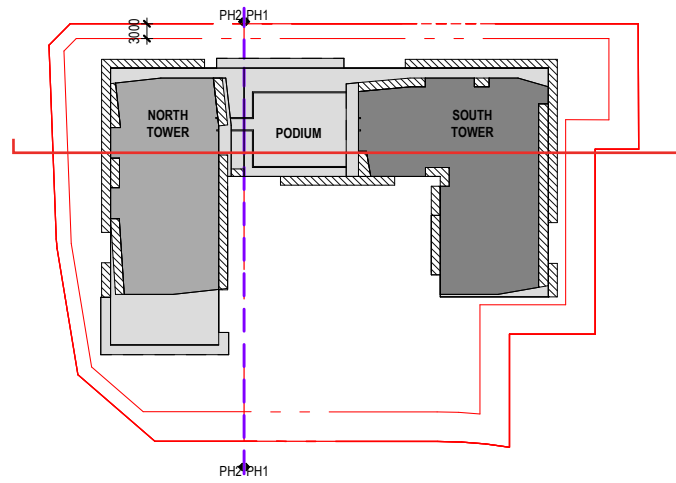

4

STATISTICS

PHASE 1 - STATISTICS

PROJECT 13 521

ORLÉANS_PHASE 1 (SOUTH TOWER)

Leaseable	LEASEABLE AREA								COMMON AREAS AND SERVICES						TOTAL						
	1 Bedroom	1 Bedroom + D	2 Bedrooms	2 Bedrooms + D	TOTAL Units	GROSS Leaseable floor (BOMA)		Estimated NET		Circulation vert. + horiz.		Technical area / utility		Amenities		Gross floor					
	1-1	1-1	2-1	2-1		Total area m ²	Total area ft ²	Total area m ²	Total area ft ²	Total area m ²	Total area ft ²	Total area m ²	Total area ft ²	Total area m ²	Total area ft ²	Total area m ²	Total area ft ²				
Level 14	9	0	5	0	14	998,0	10 742,5	863,6	9 296	143,0	1 539,3	9,0	96,9	-	-	1 153,0	12 411				
Level 13	9	0	5	0	14	998,0	10 742,5	863,6	9 296	143,0	1 539,3	9,0	96,9	-	-	1 153,0	12 411				
Level 12	9	0	5	0	14	1 000,0	10 764,0	863,6	9 296	143,0	1 539,3	10,0	107,6	-	-	1 153,0	12 411				
Level 11	9	0	5	0	14	1 000,0	10 764,0	863,6	9 296	143,0	1 539,3	10,0	107,6	-	-	1 153,0	12 411				
Level 10	9	0	5	0	14	1 000,0	10 764,0	863,6	9 296	143,0	1 539,3	10,0	107,6	-	-	1 153,0	12 411				
Level 9	9	0	5	0	14	1 000,0	10 764,0	863,6	9 296	143,0	1 539,3	10,0	107,6	-	-	1 153,0	12 411				
Level 8	9	0	5	0	14	1 000,0	10 764,0	863,6	9 296	143,0	1 539,3	10,0	107,6	-	-	1 153,0	12 411				
Level 7	9	0	5	0	14	1 000,0	10 764,0	863,6	9 296	143,0	1 539,3	10,0	107,6	-	-	1 153,0	12 411				
Level 6	9	0	5	0	14	1 000,0	10 764,0	863,6	9 296	143,0	1 539,3	10,0	107,6	-	-	1 153,0	12 411				
Level 5	9	1	4	0	14	949,0	10 215,0	863,6	9 296	142,0	1 528,5	10,0	107,6	-	-	1 101,0	11 851				
Level 4	12	3	8	0	23	1 589,0	17 104,0	1 446,0	15 565	209,0	2 249,7	16,0	172,2	-	-	1 814,0	19 526				
Level 3	12	3	8	0	23	1 589,0	17 104,0	1 446,0	15 565	209,0	2 249,7	16,0	172,2	-	-	1 814,0	19 526				
Level 2	12	3	8	0	23	1 589,0	17 104,0	1 446,0	15 565	208,0	2 238,9	16,0	172,2	-	-	1 813,0	19 515				
Level 1 Ground Floor	11	2	4	0	17	1 206,0	12 981,4	1 097,5	11 813	283,0	3 046,2	74,0	796,5	332,0	3 573,6	1 895,0	20 398				
Average unit type area	m ²	p.c.	m ²	p.c.	m ²	p.c.	m ²	p.c.	m ²	p.c.	m ²	p.c.	m ²	p.c.	m ²	p.c.	m ²	p.c.			
	60,9	656	71,6	771	86,9	936	0,0	0	15 918,0	171 341,4	14 071	151 463,8	2 338,0	25 166,2	220,0	2 368,1	332,0	3 573,6	18 814,0	202 513,9	
Total units by type	137	12	77	0																	
		149		77																	
RESIDENTIAL TOTAL	137	12	77	0	226																
UNIT MIX (%)	61%	5%	34%	0%	100%																
		66%		34%																	
TOTAL AREA RATIO						84,6%				12,4%		1,2%		1,8%					100,0%		
COMMERCIAL TOTAL																					
TOTAL																				18 814,0	202 514

PHASE 2 - STATISTICS

ORLÉANS_PHASE 2 (NORTH TOWER)																	
Leaseable	LEASEABLE AREA								COMMON AREAS AND SERVICES						TOTAL		
	1 Bedroom	1 Bedroom + D	2 Bedrooms	2 Bedrooms + D	TOTAL Units	GROSS Leaseable floor (BOMA)		Estimated NET		Circulation vert. + horiz.		Technical area / utility		Amenities		Gross floor	
	1-1	1-1	2-1	2-1		Total area m²	Total area ft²	Total area m²	Total area ft²	Total area m²	Total area ft²	Total area m²	Total area ft²	Total area m²	Total area ft²	Total area m²	Total area ft²
Level 12	1	2	3	3	9	760.0	8 180.6	637.9	6 866	118.0	1 270.2	14.0	150.7	-	-	892.0	9 601
Level 11	1	2	3	3	9	760.0	8 180.6	637.9	6 866	118.0	1 270.2	14.0	150.7	-	-	892.0	9 601
Level 10	1	2	3	3	9	760.0	8 180.6	637.9	6 866	118.0	1 270.2	14.0	150.7	-	-	892.0	9 601
Level 9	1	2	3	3	9	760.0	8 180.6	637.9	6 866	118.0	1 270.2	14.0	150.7	-	-	892.0	9 601
Level 8	1	2	3	3	9	760.0	8 180.6	637.9	6 866	118.0	1 270.2	14.0	150.7	-	-	892.0	9 601
Level 7	1	2	3	3	9	760.0	8 180.6	637.9	6 866	118.0	1 270.2	14.0	150.7	-	-	892.0	9 601
Level 6	1	2	3	3	9	760.0	8 180.6	637.9	6 866	118.0	1 270.2	14.0	150.7	-	-	892.0	9 601
Level 5	1	2	4	2	9	701.0	7 545.6	637.9	6 866	128.0	1 377.8	14.0	150.7	-	-	843.0	9 074
Level 4	4	0	9	1	14	1 107.0	11 915.7	1 007.4	10 843	166.0	1 786.8	17.0	183.0	-	-	1 290.0	13 886
Level 3	5	1	9	0	15	1 139.0	12 260.2	1 036.5	11 157	139.0	1 496.2	14.0	150.7	-	-	1 292.0	13 907
Level 2	5	1	9	0	15	1 139.0	12 260.2	1 036.5	11 157	139.0	1 496.2	14.0	150.7	-	-	1 292.0	13 907
Level 1 Ground Floor	5	2	4	1	12	937.0	10 085.9	852.7	9 178	152.0	1 636.1	104.0	1 119.5	158.0	1 700.7	1 351.0	14 542
Average unit type area	m²	p.c.	m²	p.c.		m²	p.c.	m²	p.c.							m²	p.c.
Total units by type	62,4	672	73,1	786	85,8	924	95,8	1031									
RESIDENTIAL TOTAL	27	20	56	25	128												
UNIT MIX (%)	21%	16%	44%	20%	100%												
TOTAL AREA						10 343,0	111 332,1	9 036,3	97 266,7	1 550,0	15 048,1	261,0	1 689,9	158,0	1 700,7	12 312,0	132 526,4
RATIO						84,0%				12,6%		2,1%		1,3%		100,0%	
COMMERCIAL TOTAL												16%					
TOTAL																12 312,0	132 526

5

VIEWS

PRECEDENTS

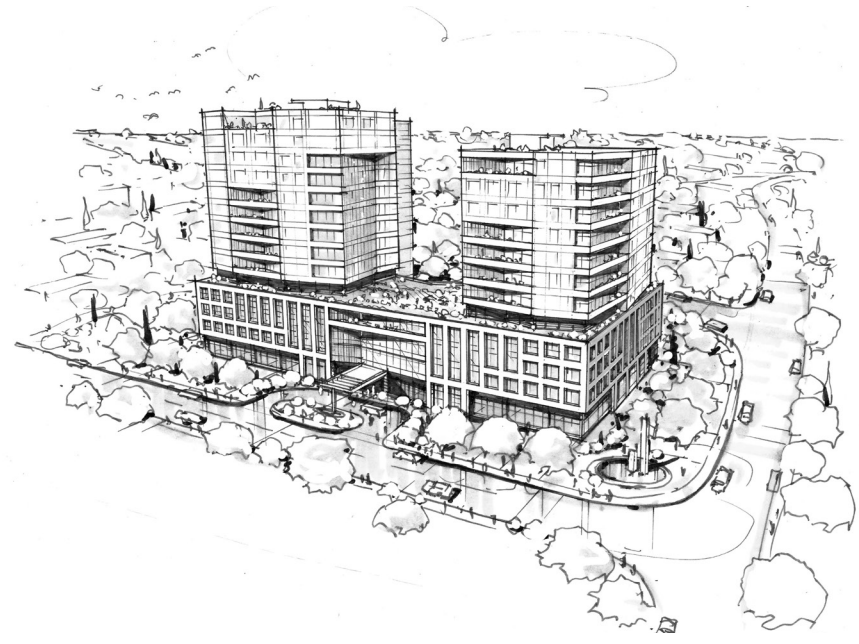

REFERENCE IMAGES



THE SMITH, Boston



Rouen Luciline - Rives de Seine, Rouene

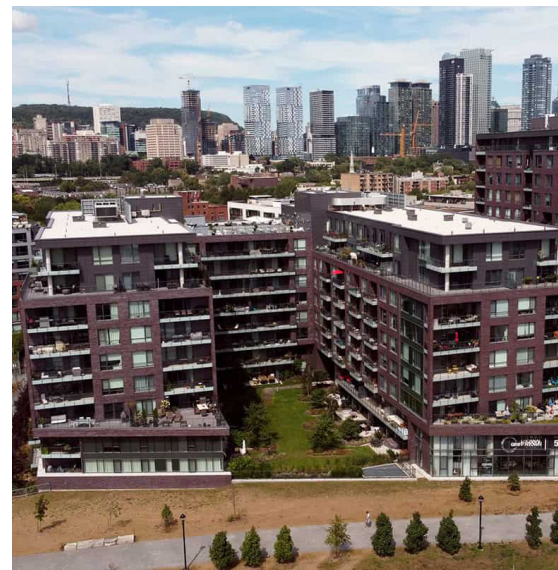

GALDIN, Griffintown Montréal



One Vince Street, London



Plomb, Amsterdam

PEDESTRIAN VIEW 1



PEDESTRIAN VIEW 2



6

ELEVATIONS AND MATERIALITY

WEST ELEVATION

VIEW FROM
BILBERRY DRIVE PROM.

1:400

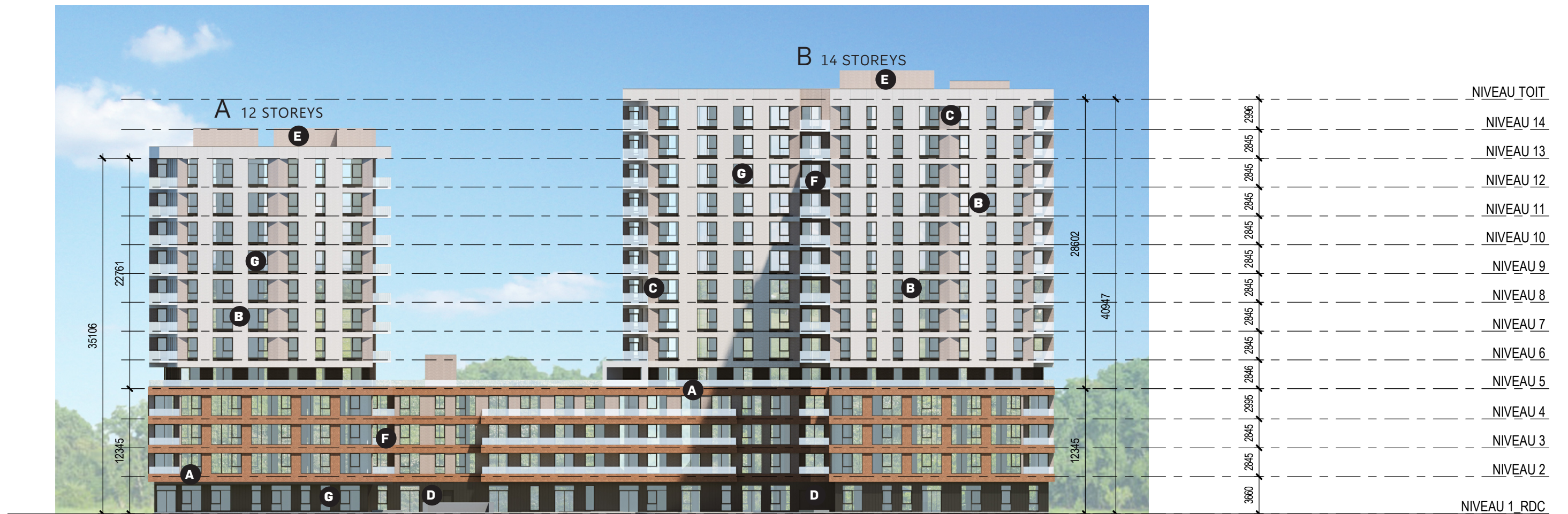
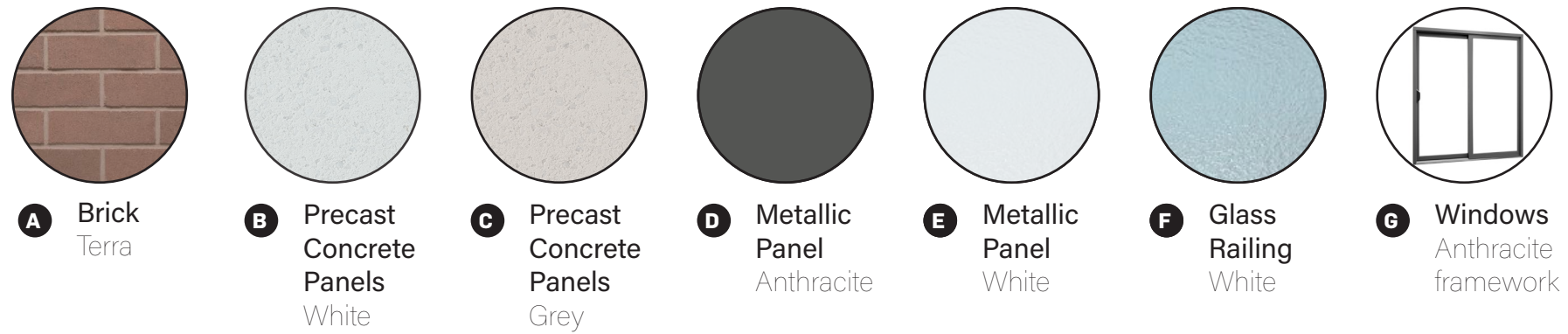

SOUTH ELEVATION

1:400

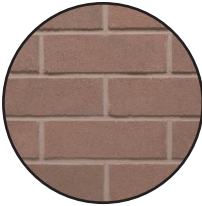
- 

A Brick
Terra
- 

B Precast
Concrete
Panels
White
- 

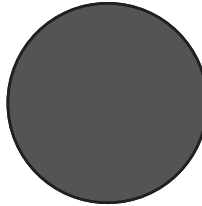
C Precast
Concrete
Panels
Grey
- 

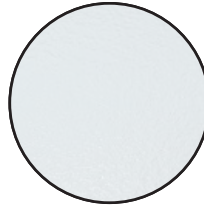
D Metallic
Panel
Anthracite
- 

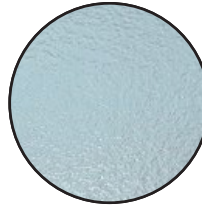
E Metallic
Panel
White
- 

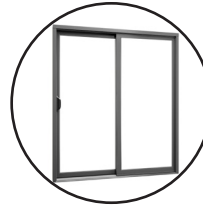
F Glass
Railing
White
- 

G Windows
Anthracite
framework

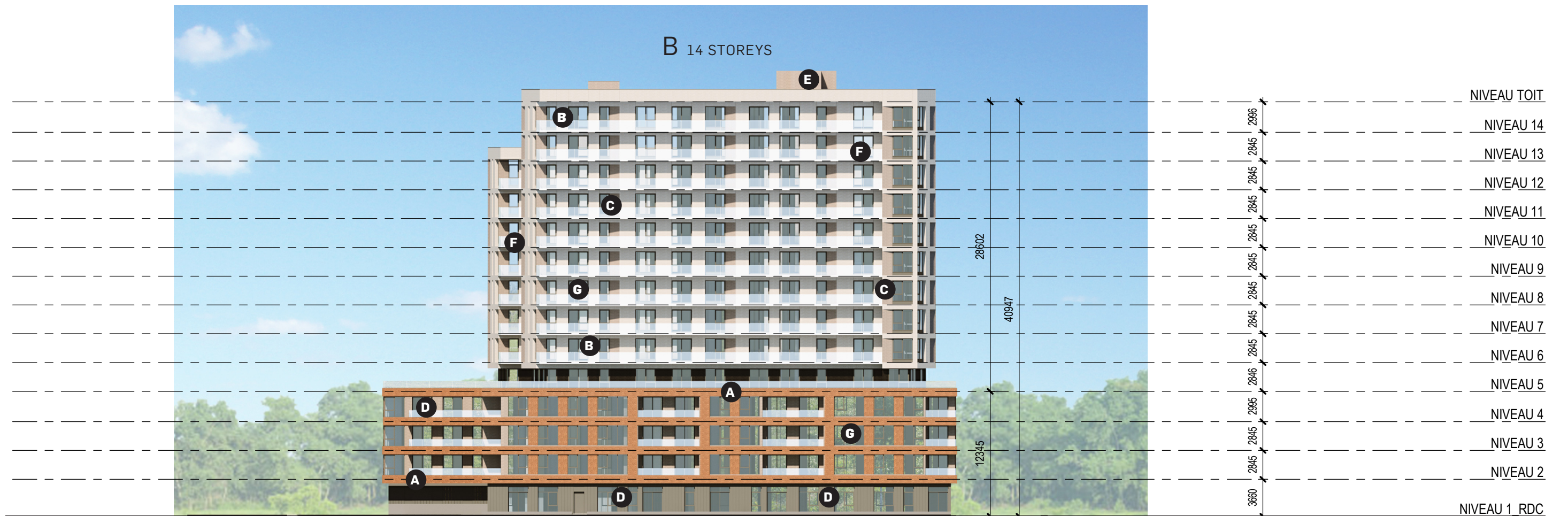

EAST ELEVATION

VIEW FROM
FAMILLE-COTÉ AV.

1:400

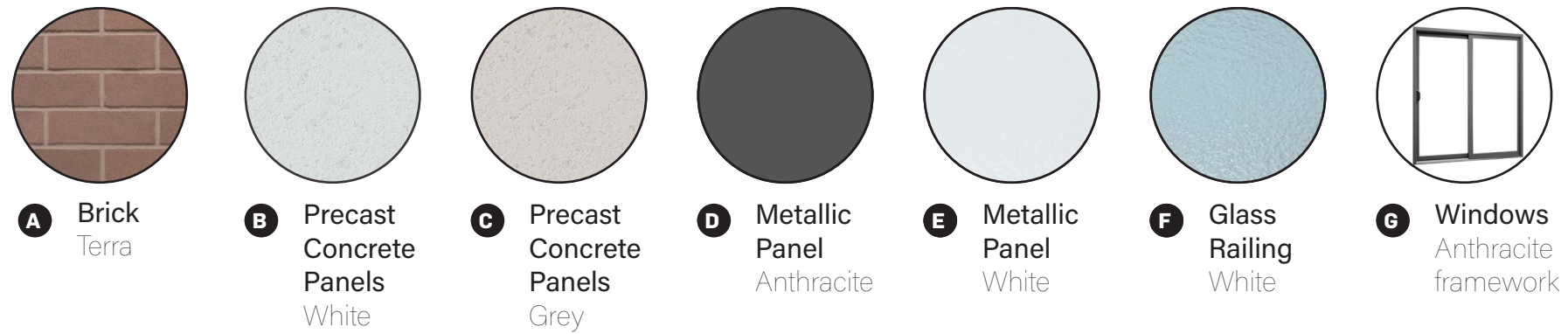

NORTH ELEVATION

VIEW FROM
JEANNE-D'ARC BD.

1:400

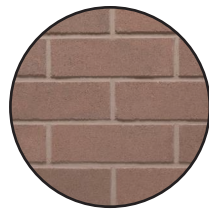

A Brick
Terra



B Precast
Concrete
Panels
White



C Precast
Concrete
Panels
Grey

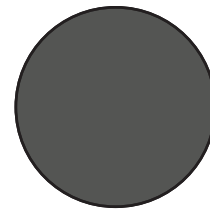

D Metallic
Panel
Anthracite

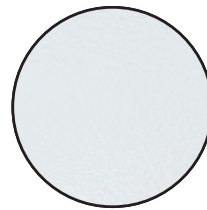

E Metallic
Panel
White

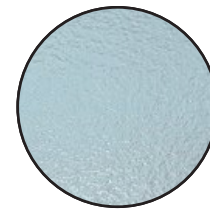

F Glass
Railing
White

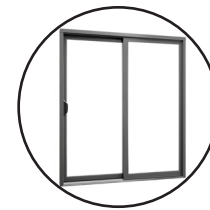

G Windows
Anthracite
framework

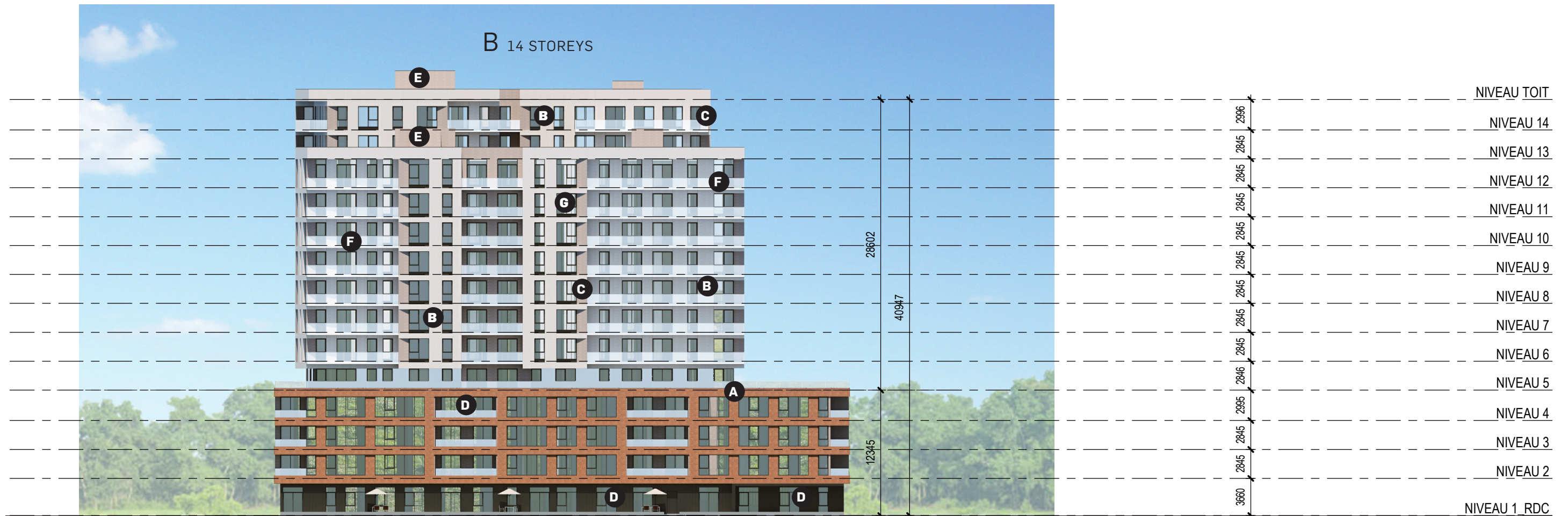

INTERIOR NORTH ELEVATION

1:400

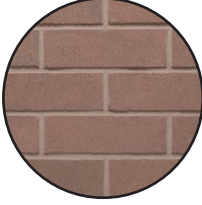
- 

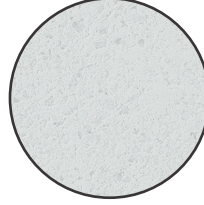
A Brick
Terra
- 

B Precast
Concrete
Panels
White
- 

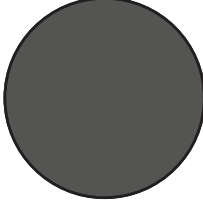
C Precast
Concrete
Panels
Grey
- 

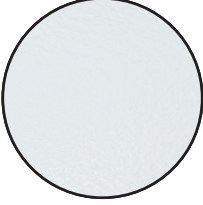
D Metallic
Panel
Anthracite
- 

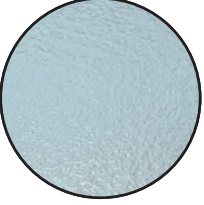
E Metallic
Panel
White
- 

F Glass
Railing
White
- 

G Windows
Anthracite
framework

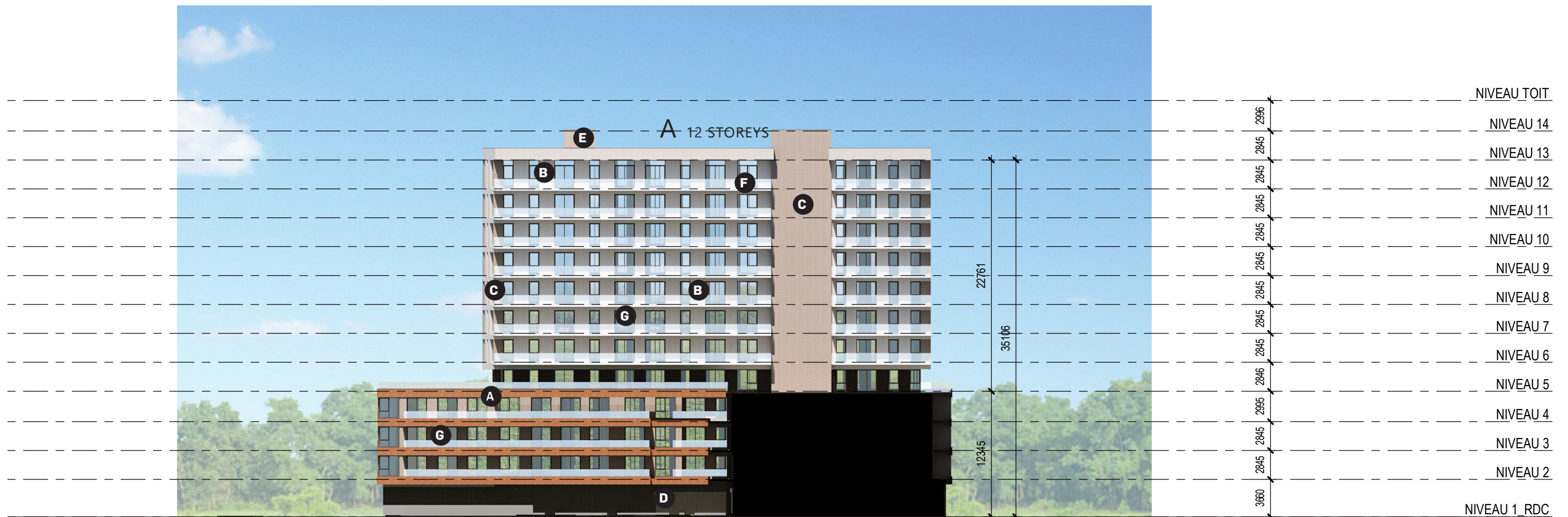

INTERIOR NORTH ELEVATION

1:400

- 

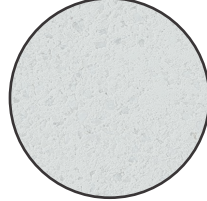
A Brick
Terra
- 

B Precast
Concrete
Panels
White
- 

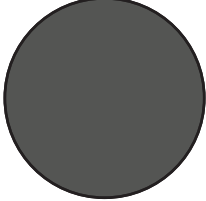
C Precast
Concrete
Panels
Grey
- 

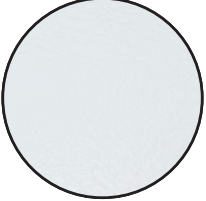
D Metallic
Panel
Anthracite
- 

E Metallic
Panel
White
- 

F Glass
Railing
White
- 

G Windows
Anthracite
framework



7

SUN AND WIND STUDIES



SUN STUDY- ACTUAL SITE

MARCH 21 & SEPTEMBER 21 (EQUINOXES)



9h00



12h00



15h00



18h00

JUNE 21 (SUMMER SOLSTICE)



9h00



12h00



15h00



18h00

DECEMBER 21 (WINTER SOLSTICE)



9h00



12h00



15h00



18h00



MARCH 21 & SEPTEMBER 21 (EQUINOXES)



9h00



12h00



15h00



18h00

JUNE 21 (SUMMER SOLSTICE)



9h00



12h00



15h00



18h00

DECEMBER 21 (WINTER SOLSTICE)



9h00



12h00



15h00



18h00

8

APPROACH TO SUSTAINABILITY

APPROACH TO SUSTAINABILITY



1 VEGETATION

INCREASING GREENSPACE

- Increasing the amount of vegetation to maximise carbon sequestration by incorporating greenroofs and a considered landscaping strategy.
- Providing users with a close visual proximity to sufficient greenspace; promoting positive mental and physical health effects (in accordance with notions of biophilia).
- Considering non-human users: creating habitats to support healthy ecosystems and promote biodiversity within urban areas.
- Use of various native species on site.
- Use of vegetation to retain rainwater and prevent an overload of the stormwater system.

2 CIRCULARITY

- Consideration of the lifecycle of the materials used in the building construction; using recycled and materials with low embodied energy where possible. Understanding maintenance costs of materials and their future impacts.
- Ensuring adaptability of the building design so it can meet the needs of future residents and/or a future change in programmatic use.

3 MATERIALS

- Utilising prefabricated modular panels reduce waste and lower construction time.
- Use of locally sourced materials (within 880km) to reduce transportation loads.

MATERIAL CHOICE:

- Choosing sustainable materials with lower embodied energies such as prefabricated concrete panels, aluminium and glass.
- Ensuring FSC certification where appropriate.
- Ensuring materials are free of volatile organic compounds (VOCs) and added formaldehyde (in bonded panels).
- Understanding the energy required to extract compounds and process materials at a manufacturing stage to ensure a sustainable approach is taken throughout the material's lifecycle.

MATERIAL EFFICIENCY

- Integration of the most efficient materials and insulators such as white membranes to limit heat loss therefore reducing energy loads and costs.
- Minimise thermal bridging and exceed the latest energy code requirements.

4 BIRD SAFE DESIGN

The project meets the city's requirements for bird protection.

5 ENERGY USAGE

- Using energy from a renewable source: Geothermal
- Setting up an energy sharing network between the different buildings. A main heatpump will draw energy from the geothermal source and ensure the water network is maintained at the right temperatures, using CO2 as a refrigerant.
- Use of most efficient air exchangers (85%) to reduce energy loads and costs required for ventilation.
- Use of water-saving toilet equipment (dual-flush toilets, low-flow shower heads).
- Collection of rainwater to be used as greywater (for flushing toilets and watering vegetation).
- High level temperature and humidity control; Use of an air exchanger in all rental units.
- Utilising operable glazing and shading strategies to provide a user-controlled internal climate, reducing ventilation and cooling loads. Implementation of passive systems where possible.

6 RESIDUAL MATTERS

- Space in each dwelling for waste, recycling and compost bins.
- Sorting and recycling of waste materials and control of material losses on site.

7 WELLNESS

- Consideration of user experience: Providing thermal comfort, natural lighting, operable windows, quality views, suitable acoustics of dwellings and courtyards.
- Installation of drinking water fountains designed for filling water bottles.
- Providing a gymnasium, yoga area and other spaces to maintain physical fitness mental health.
- Offer of co-working space to encourage social interactions between tenants.
- Visually calming and comfortable circulation and common areas to increase accessibility.
- No smoking inside and within 25 feet of the building

8 MOBILITY

- Road and bicycle networks providing access to cycle tracks and public parks.
- Offer of car and bicycle sharing.
- Close connection to major rail network and multiple local bus routes contribute to well established public transport system.

9 SENSE OF COMMUNITY

- Providing a community garden as a means for tenants to socialise, learn about food management and healthy diets as well as reducing food waste.
- Variety of units (1, 1+den, 2, 2+den bedrooms) to satisfy the needs of a diverse clientele.
- Careful consideration of common areas to promote social interactions and foster community spirit.
- Providing adaptable spaces to be used by the tenants for community events and clubs etc.



WIND STUDY, CIVIL AND LANDSCAPE

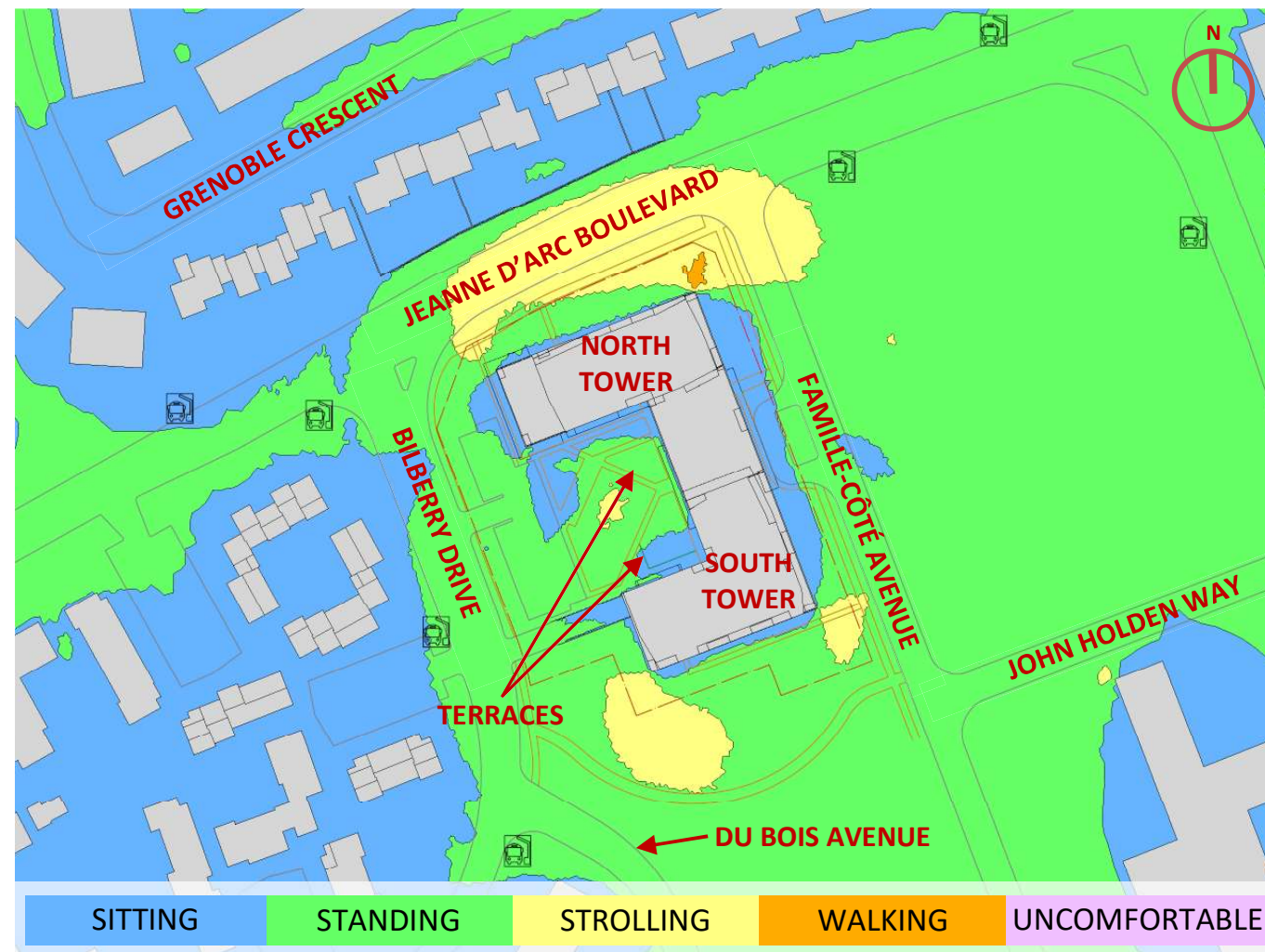

FIGURE 3A: SPRING – WIND COMFORT, GRADE LEVEL – PROPOSED MASSING

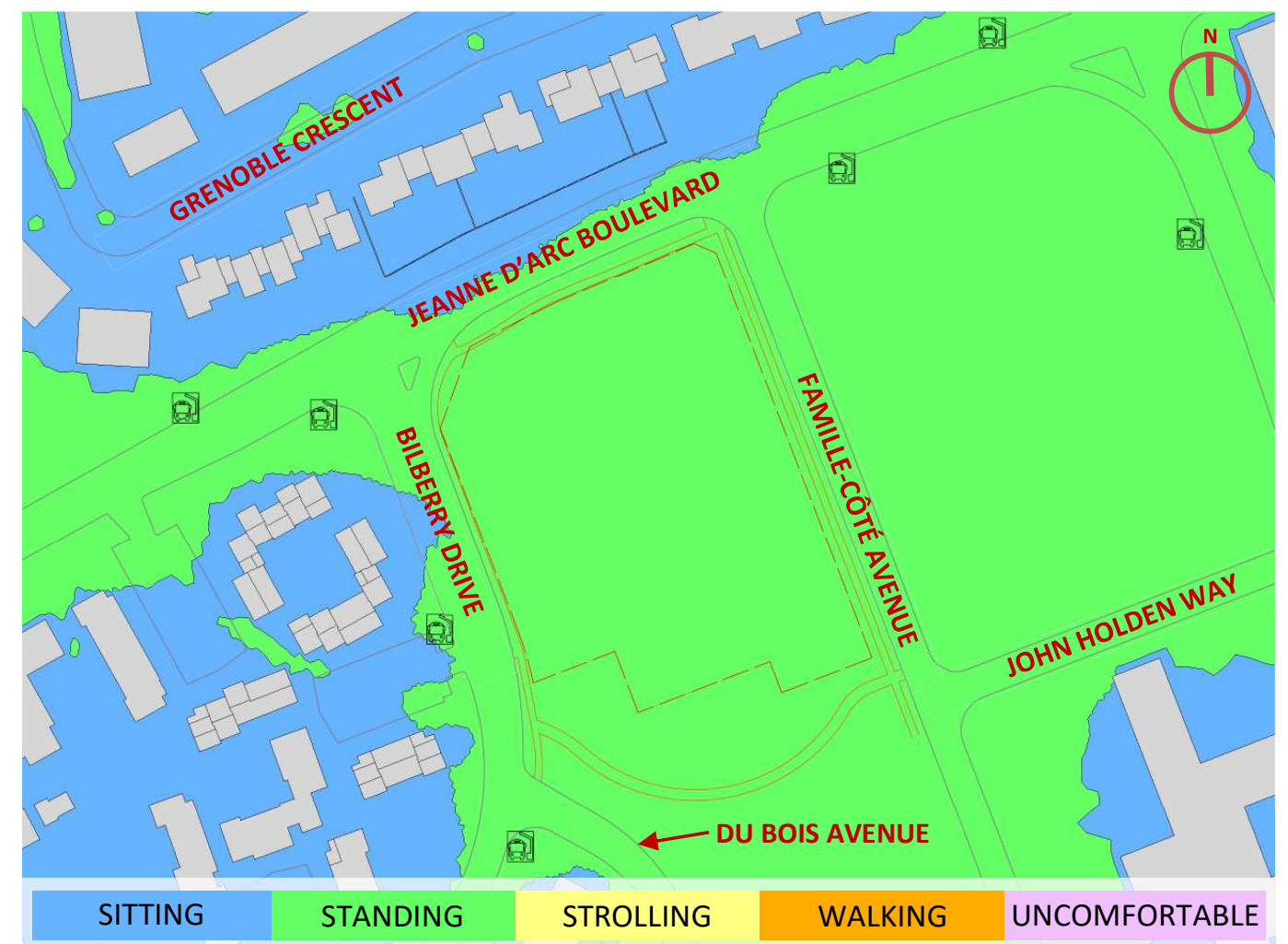

FIGURE 3B: SPRING – WIND COMFORT, GRADE LEVEL – EXISTING MASSING

WIND STUDY - SUMMER

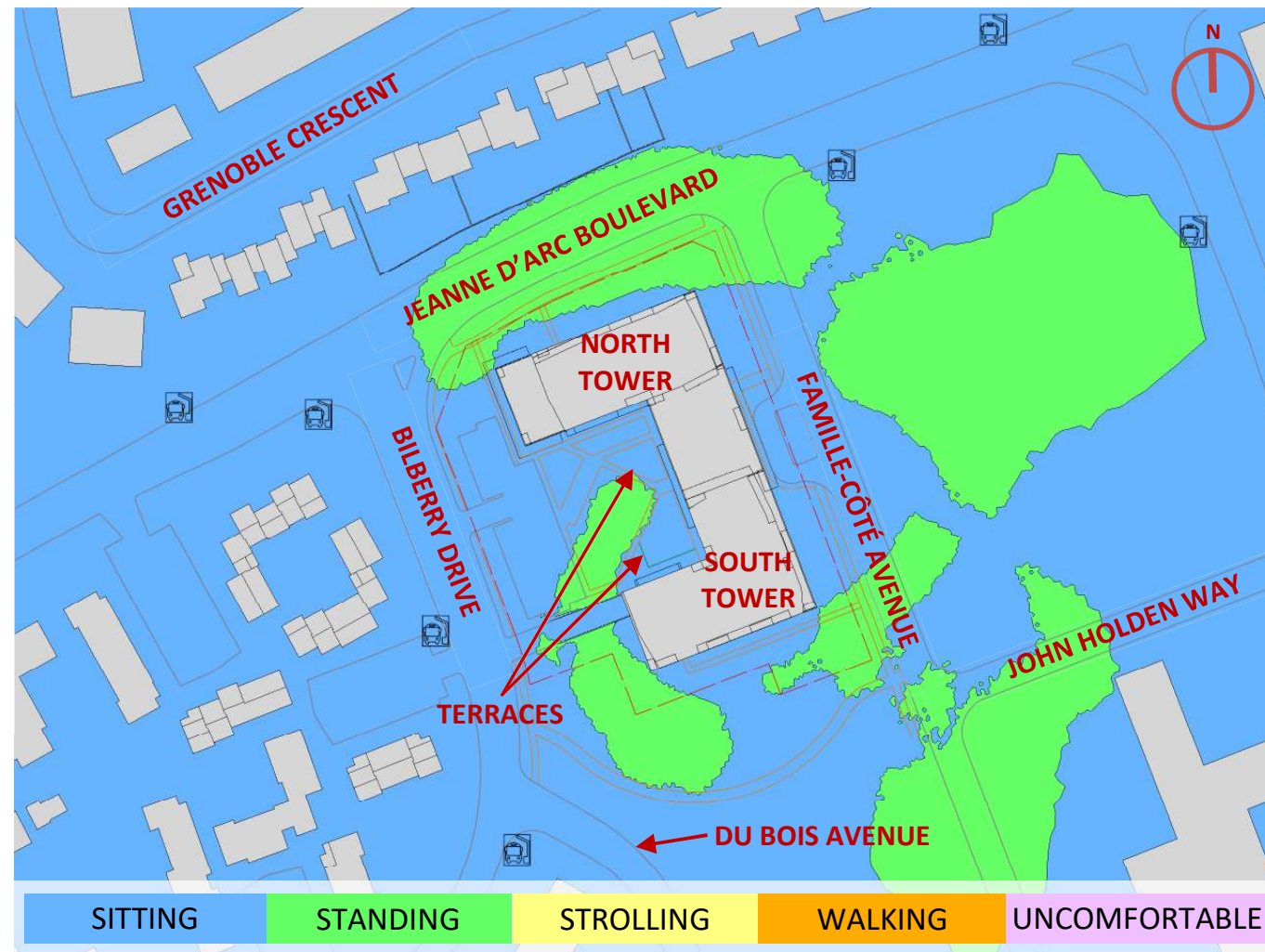

FIGURE 4A: SUMMER – WIND COMFORT, GRADE LEVEL – PROPOSED MASSING

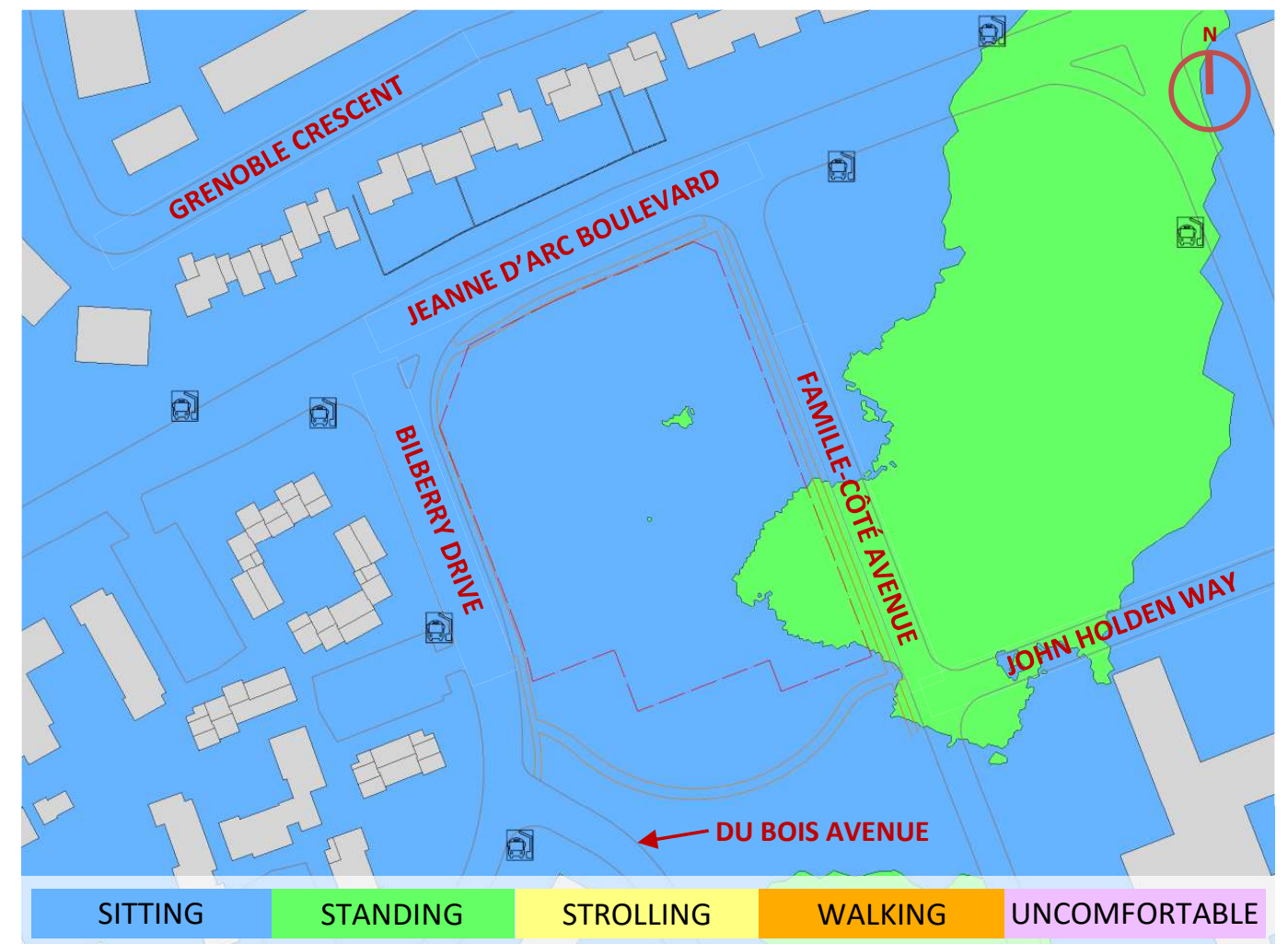

FIGURE 4B: SUMMER – WIND COMFORT, GRADE LEVEL – EXISTING MASSING

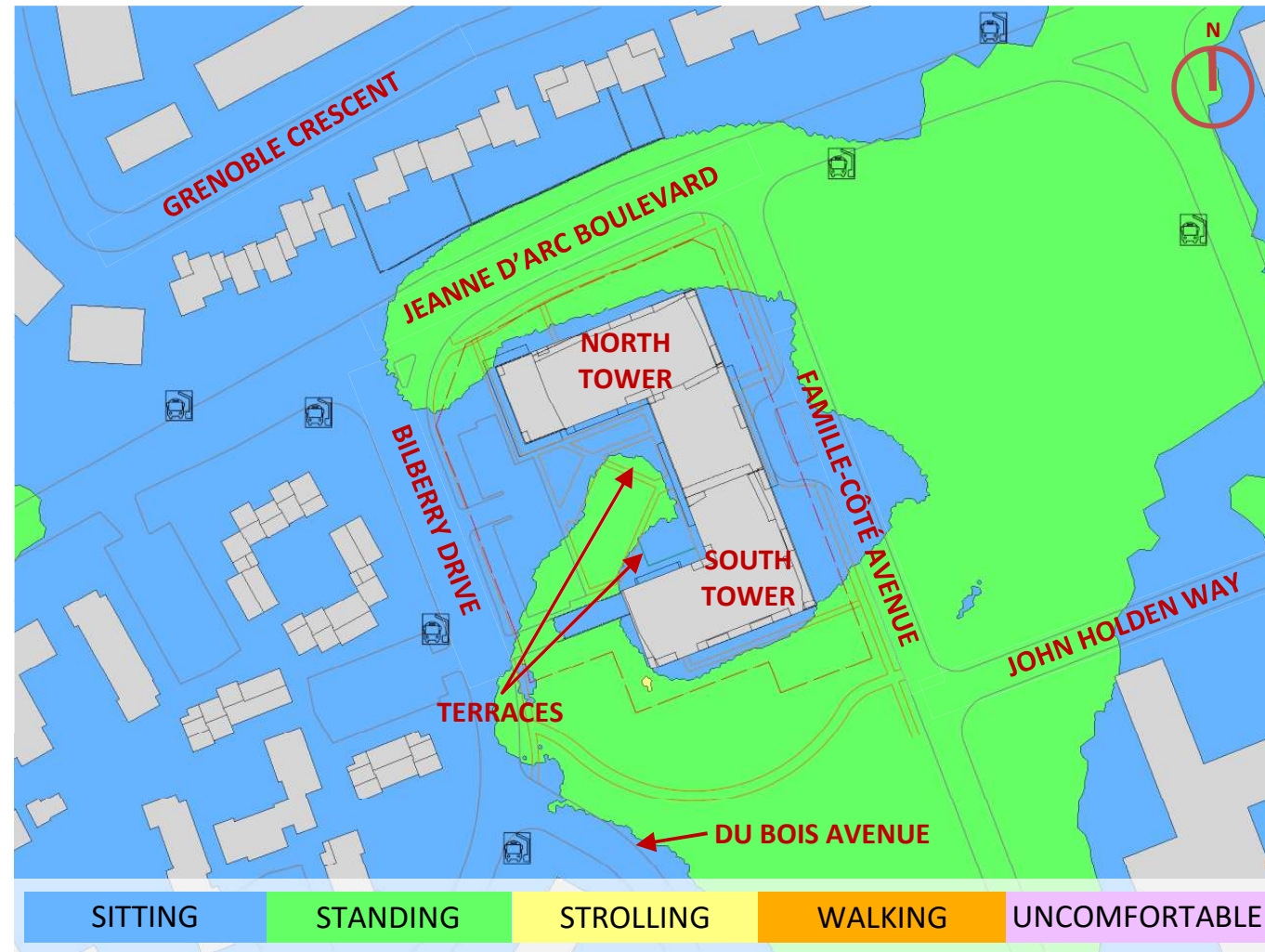

FIGURE 5A: AUTUMN – WIND COMFORT, GRADE LEVEL – PROPOSED MASSING

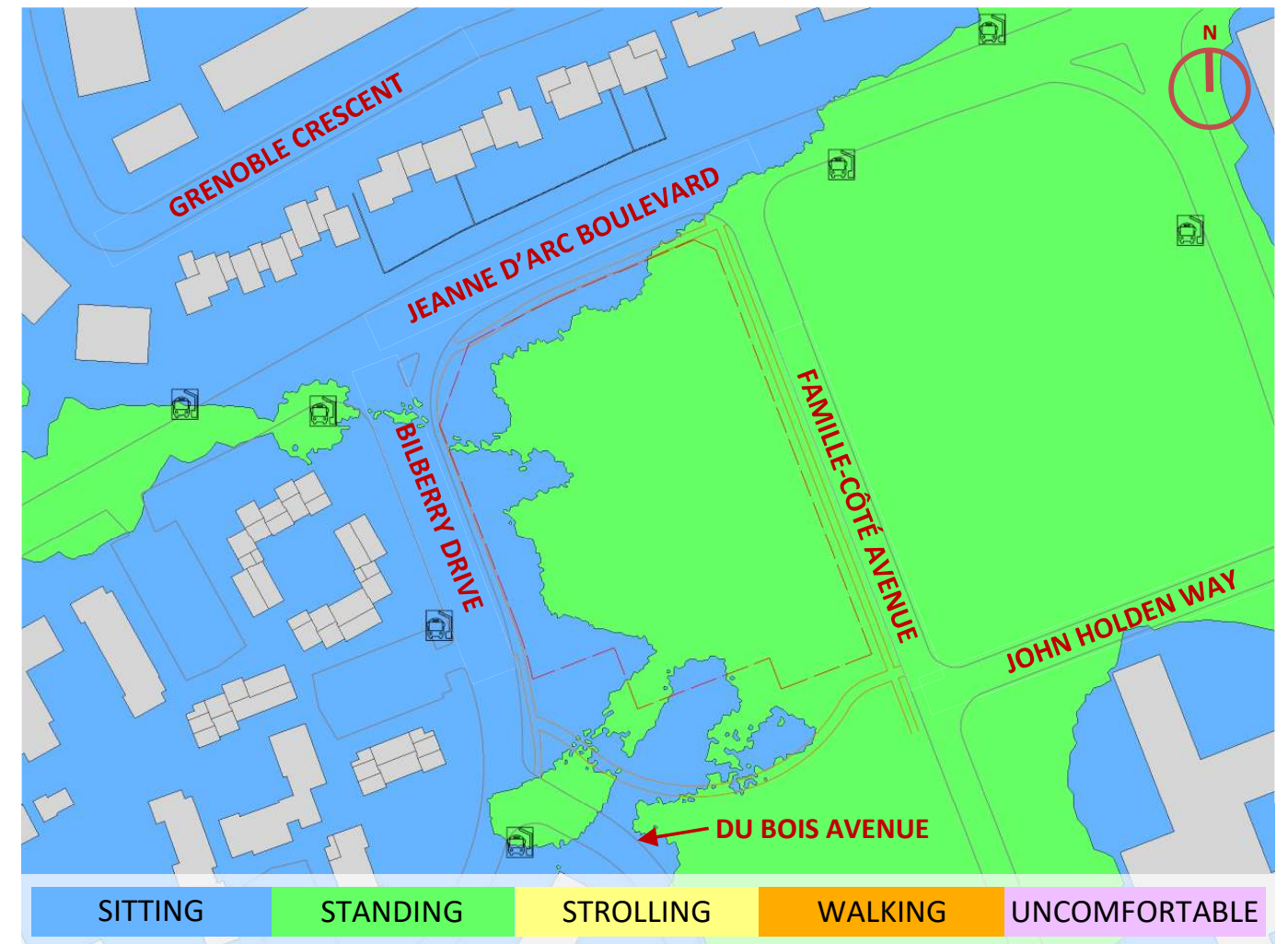

FIGURE 5B: AUTUMN – WIND COMFORT, GRADE LEVEL– EXISTING MASSING

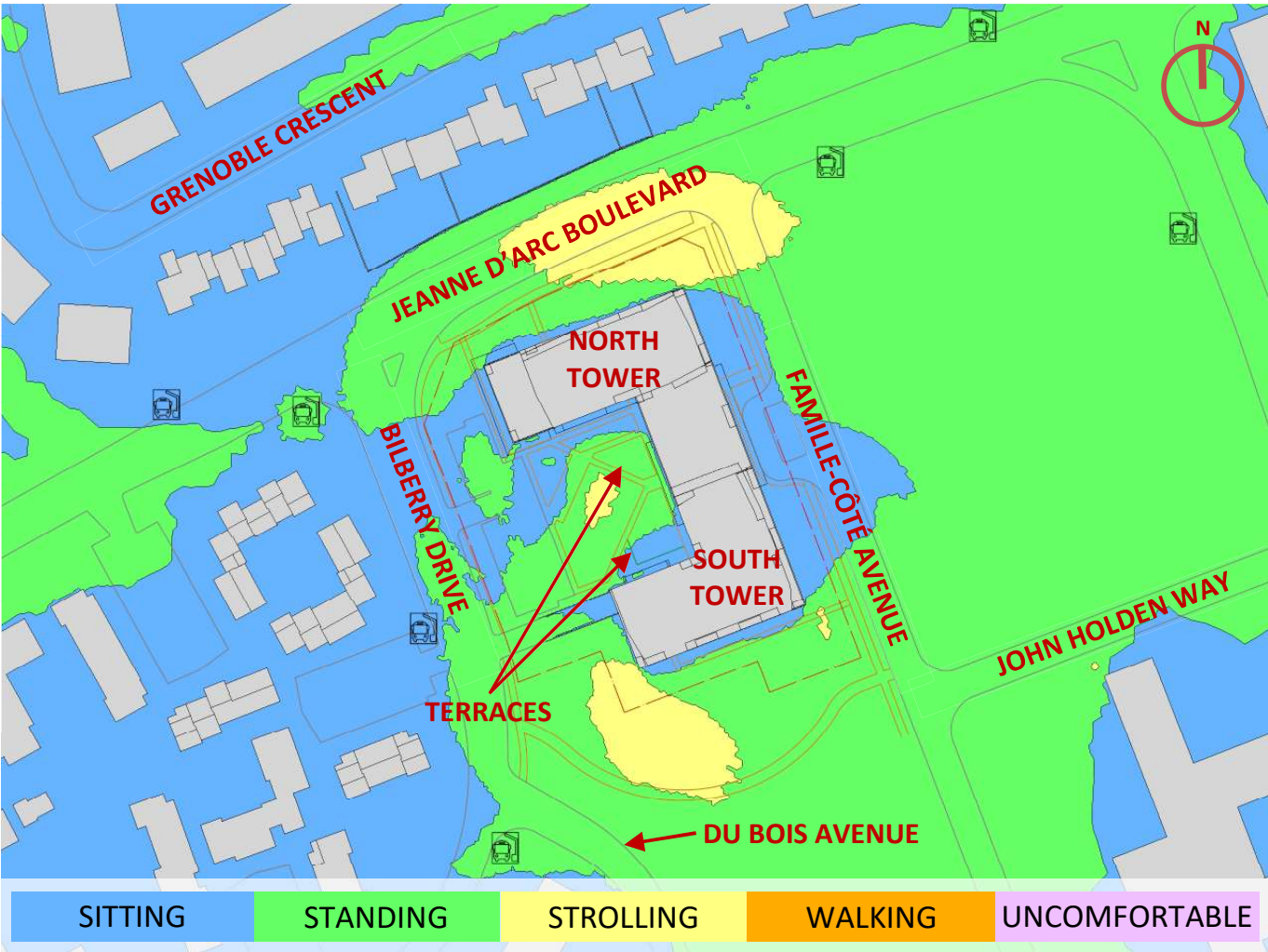

FIGURE 6A: WINTER – WIND COMFORT, GRADE LEVEL – PROPOSED MASSING

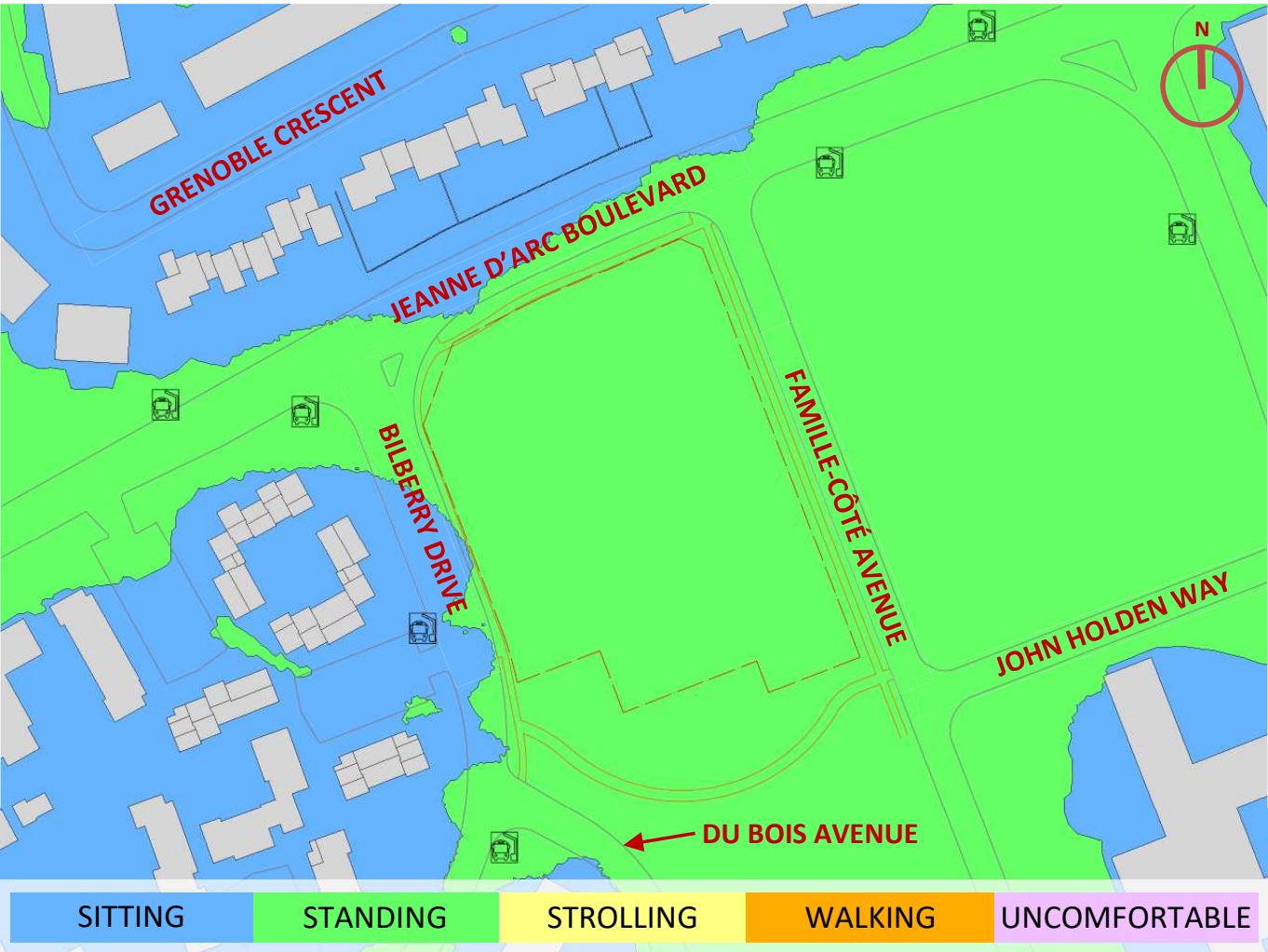

FIGURE 6B: WINTER – WIND COMFORT, GRADE LEVEL– EXISTING MASSING

TECHNICAL AND GENERAL SPECIFICATIONS

1.0 GENERAL SPECIFICATIONS

All work shall conform with Ontario building code, latest edition as well as local regulation and bylaws.

Contractor to verify all dimensions and report any discrepancies to the engineer immediately to get design confirmation before proceeding with construction.

Refer to the City of Ottawa for regulations and standards (supersedes provincial standards).

Refer to Ontario Provincial Standards for Roads and Public Works - Volume 3 for details.

Ontario provincial standards for roads and public works must also be respected.

Work to be performed in accordance with the Occupational Health and Safety Act and Regulations for Construction Projects.

All materials shall meet all current applicable standards set by the American Water Works Association ("AWWA"), Canadian Standards Association ("CSA"), the American National Standards Institute ("ANSI") safety criteria standards, American Society for Testing and Materials (ASTM), NSF/31, NSF/60 and NSF/61.

The Contractor will get approval for all materials selection from the Civil Engineer prior to delivery to the site.

BUILDING OWNER: BÂTIMO DÉVELOPPEMENT INC.

CONSULTING CIVIL ENGINEER: ÉQUIPE LAURENCE INC.

2.0 GENERAL INFORMATIONS

2.1 UNDERGROUND SERVICES

The plans show certain underground installations for the sole purpose to highlight the existence of cables, pipelines and underground structures. In the sectors where work must be performed, the contractor is responsible to verify himself with the competent authorities the existence and actual location of all cables, pipelines and existing underground structures that may affect the works.

Before beginning excavations, the contractor must thus contact the Ontario One Call (www.on1call.com), the municipal authorities and all other stake holders in order to identify on the field all existing underground structures whether they are shown on the plans or not.

He is responsible for damages to cables, pipelines and underground structures. No cost variation resulting from underground structures not shown or poorly located on the plans can be claimed against the building owner. Following the review of the plans and specifications, the contractor must notify the engineer of any error, omission or discrepancy noted by him before starting work.

2.2 EXISTING WATERMAIN AND SEWER CONDUITS

The location of the watermain and sewer pipes is approximate. The contractor must verify and validate the position and depth of the pipes by the means of meticulous excavations. Should discrepancies be observed, they must be provided to the engineer without delay in order that the required modifications are made to the construction plans. The contractor will have to coordinate with the city the connecting works to the existing networks (watermain and sewers). No service interruption shall take place without the building owner's authorization or the relevant authorities.

2.3 PROTECTION AGAINST EROSION

As per "Erosion and sediment control guideline for urban construction"

In all areas of the building site where there is a risk of erosion, the ground must be stabilized. Runoff water must be intercepted and routed to stabilized areas and this, throughout the construction period. The contractor must use the recognized methods to prevent the transport of sediments.

- Sediment barrier
- Mud mat
- Sedimentation pond
- Filtering berm and sediment trap
- Straw bale filter

Any intervention on the building site which may cause the transfer of sediments must be simultaneously accompanied by sediment capture measures.

2.4 DRAINING OF THE EXCAVATIONS

The contractor shall take all necessary precautions to prevent the penetration of surface waters and to evacuate surface, underground or sewer waters. Waste waters must be directed towards a combined sewer or a sanitary sewer and the surface and underground waters towards a storm sewer, a combined sewer or a ditch. In all cases, the diversion site must be submitted for approval. The contractor must assume all required pumping and cleaning costs.

2.5 PAVEMENT PROTECTION

At all times, the movement of machinery and metal tracked vehicles is prohibited on paved surfaces unless plywood sheets with a 20mm normal thickness or rubber with a 12.5mm thickness are used in order to avoid damaging pavement. All repairs or complete replacements of pavement is the contractor's responsibility, who will have to pay all the costs.

2.6 CLEANING OF SITE

At the end of the construction works and as often as requested by the project superintendent, the contractor must clean and eliminate all construction generated debris and restore all construction affected areas. The cleaning of the construction site is included in the global market unit prices.

3.0 SITE GRADING

Surface topsoil layer stripping required.

Low-lying areas may be filled by utilising soil cut from higher areas and by importing suitable fill materials.

The approved subgrade may be raised to design subgrade level with approved compactable on-site soil, providing it is placed in maximum 300 mm thick lifts and each lift is compacted to at least 95% of the material's SPMDD. As an alternative to subconcretion, a woven geotextile separator, such as Terratrack 24-15, Amoco 2002, Mirafi 500XL or equivalent, may be placed over spongy areas prior to placing the Granular 'B' sub-base layer.

4.0 CONCRETE WORKS

All weather exposed concrete shall have 5 to 8% air entrainment or as otherwise specified in Tables 2 and 4 of CSA A23.1.

Concrete sidewalk as per OPSD 310.010. Foundation consist of 150 mm minimum of granular 'A' material. Sidewalk concrete thickness shall be 200 mm.

Concrete barrier curb as per OPSD 600.110. Foundation consist of 150 mm minimum of granular 'A' material.



PROJECT LOCATION
NO SCALE

CIVIL ENGINEERING LEGEND

	EXISTING BUILDING
	PROPOSED BUILDING
	BOTTOM OF EMBANKMENT
	TOP OF EMBANKMENT
	DITCH CENTER
	DITCH TO BE REMOVED
	DITCH CENTER WITH ROCK FILL PROTECTION
	EXISTING FENCE
	FENCE TO BE REMOVED
	PROPOSED FENCE
	SILT FENCE BARRIER
	ISOLATED WETLAND
	EXISTING TREE
	WOODED AREA
	WOODED AREA TO BE REMOVED
	OVERLAND FLOW ROUTE
	GUARDRAIL
	STONE RETAINING WALL
	EXISTING FIRE HYDRANT
	PROPOSED FIRE HYDRANT
	EXISTING WATER SERVICE VALVE
	PROPOSED WATER SERVICE VALVE
	EXISTING WATER PIPE
	EXISTING WATER PIPE TO BE REMOVED
	PROPOSED WATER PIPE
	EXISTING DRINKING WATER SERVICE CONNECTION
	PROPOSED DRINKING WATER SERVICE CONNECTION
	EXISTING SANITARY SEWER AND MANHOLE
	PROPOSED SANITARY SEWER AND MANHOLE
	EXISTING STORM SEWER PIPE AND MANHOLE
	PROPOSED STORM SEWER PIPE AND MANHOLE
	STORM SEWER AND MANHOLE TO BE REMOVED
	CULVERT
	EXISTING CATCH BASIN OR MANHOLE-CATCH BASIN
	PROPOSED CATCH BASIN OR MANHOLE-CATCH BASIN
	EXISTING STORM SEWER MANHOLE
	PROPOSED STORM SEWER MANHOLE
	EXISTING SANITARY SEWER MANHOLE
	PROPOSED SANITARY SEWER MANHOLE
	LIGHTNING UNIT
	OVERHEAD WIRING AND GUY WIRE
	EXISTING GAS PIPELINE
	BELL CANADA UNDERGROUND CABLE
	UNDERGROUND ELECTRICAL WIRE
	PROPOSED ASPHALT SURFACE
	PROPOSED CONCRETE SIDEWALK/SLAB
	PAVER SIDEWALK
	PROPOSED GRASS SURFACE
	GRANULAR SURFACE
	PROPOSED TEMPORARY MUD MAT
	PROPOSED STONES SURFACE
	PROPOSED GRANITE STONES
	EXISTING ASPHALT SURFACE TO BE REMOVED
	EXISTING SURFACE TO BE REMOVED
	PROPOSED ELEVATION
	PROPOSED ELEVATION OF CONCRETE CURB
	PROPOSED ELEVATION OF CONCRETE SLAB
	PROPOSED TOP ELEVATION OF GRASS
	PROPOSED TOP ELEVATION OF SIDEWALK
	PROPOSED TOP ELEVATION OF RETAINING WALL
	PROPOSED BOTTOM ELEVATION OF RETAINING WALL
	EXISTING ELEVATION OF SURFACE
	GRADING SLOPES
	NORTH

THIS DOCUMENT MUST NOT BE USED FOR CONSTRUCTION

REV	DESCRIPTION	PAR	DATE
D	FOR COORDINATION		B.B. 2025-05-08
C	FOR SITE PLAN APPLICATION REV.01		B.B. 2025-02-05
B	FOR SITE PLAN APPLICATION		B.B. 2025-12-11
A	FOR UDRP		B.B. 2025-09-15

CLIENT: BÂTIMO DÉVELOPPEMENT INC.
SUITE 400-8485, RUE DORRIS-LUSSIER
DORRISBRAND, QUÉBEC
J7H 0E8

PROJET: LIB ORLÉANS
500 FAMILLE-CÔTÉ AVENUE
OTTAWA



135, boulevard de Sainte-Adèle, Sainte-Adèle (QC) J8B 0J4
T 450 227 1857
info@equipe-laurence.ca | equipe-laurence.ca

SCAU:

TITRE DU PLAN: TECHNICAL AND GENERAL SPECIFICATIONS' LEGEND AND NOTES LOCATION

ÉCHELLE: AUCUNE ÉCHELLE

ÉQUIPE DU PROJET: L-C. TELLIER, tech.
V.MERCIER, ing.

DOSIER NO: 601401

NOUVEAU: C-201.dwg

PRÉPARÉ PAR: B.BRAY, ing.

C-201

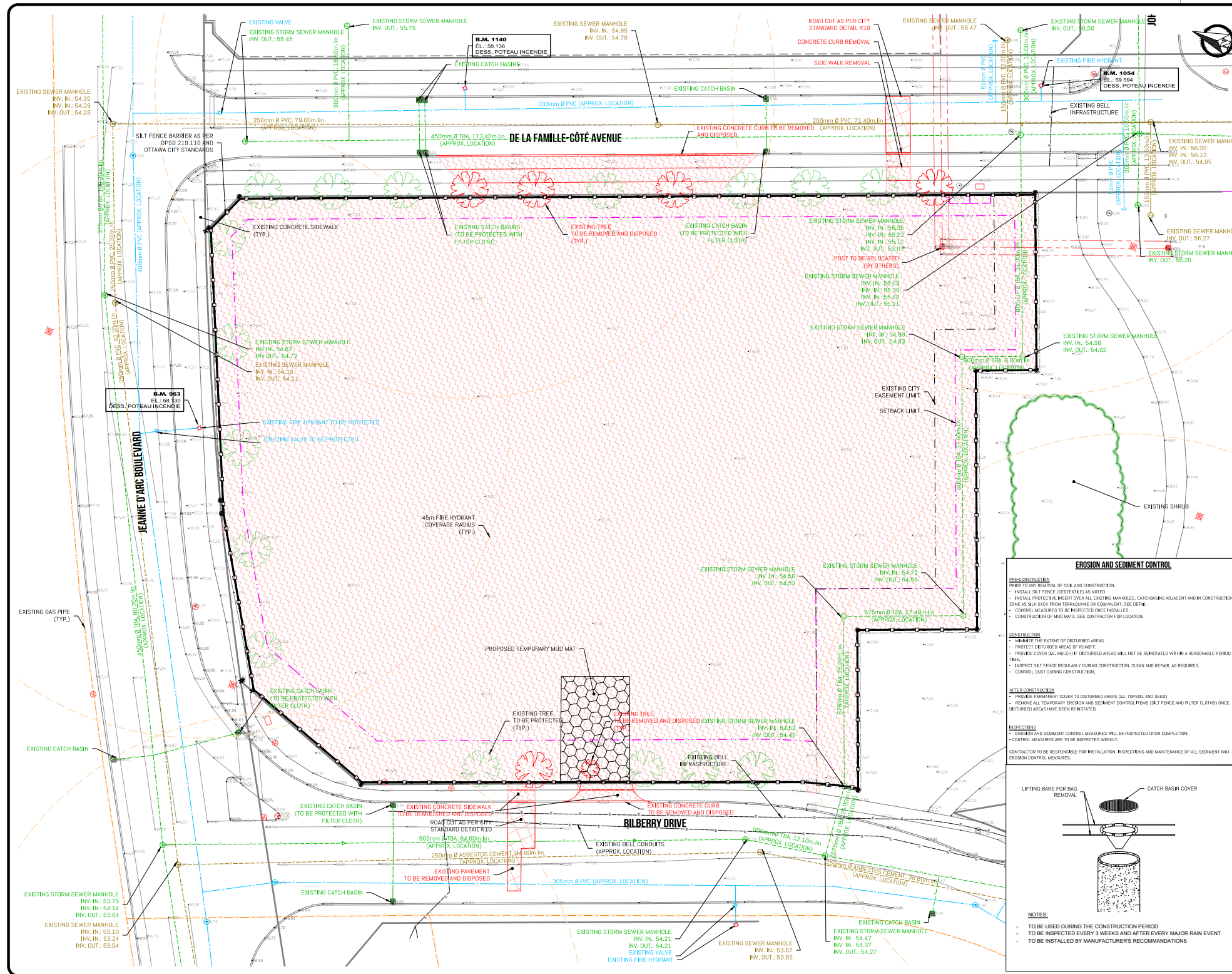

NOTE:
THE EXISTING AND PROPOSED SUBDIVISION WILL HAVE TO BE VALIDATED BY THE SURVEYOR-GEODETIC ON FILE.

SURVEY AND LOTS INFORMATION PROVIDED BY ANNIS, O'SULLIVAN, VOLLEBEKK LTD.
DATE: AUGUST 19 2024
FILE NO.: V-110337
PLANIMETRIC REFERENCE SYSTEM: MTM NAD 83 ZONE 9
ALTIMETRIC REFERENCE SYSTEM: CGVD28 HT2.0

THE CONTRACTOR MUST NOTIFY ÉQUIPE LAURENCE, THE CONSULTANT, IF HE NOTICES ANY DISCREPANCIES BETWEEN THE INFORMATION PRESENTED ON THE PLANS AND THE MEASUREMENTS TAKEN ON SITE SO THAT ADJUSTMENTS CAN BE MADE.
WHEN APPLICABLE, HE MUST ALSO VERIFY THE ELEVATIONS OF EXISTING SEWERS BEFORE STARTING CONSTRUCTION AND MUST PROVIDE THE INFORMATION TO THE CONSULTANT.

THIS DOCUMENT MUST NOT BE USED FOR CONSTRUCTION

REV	DESCRIPTION	DATE
D	FOR COORDINATION	B.B. 2025-05-08
C	FOR SITE PLAN APPLICATION REV.01	B.B. 2025-02-05
B	FOR SITE PLAN APPLICATION	B.B. 2025-12-11
A	FOR UDRP	B.B. 2025-09-15

CLIENT: BÂTIMO DÉVELOPPEMENT INC.
SUITE 400-8485, RUE DORIS-LUSSIER
BOISBRAND, QUÉBEC
J7H 0E8

PROJET: LIB ORLÉANS
500 FAMILLE-CÔTÉ AVENUE
OTTAWA

135, boulevard de Sainte-Adèle, Sainte-Adèle (Qc), J8B 0J4
T 450 227 1857
info@equipe-laurence.ca | equipe-laurence.ca

SCAOU

TITRE DU PLAN: PLAN VIEW
EXISTING ITEMS AND DEMOLITION

ÉCHELLE: Horizontale 1:250 0 2.5 5 12.5 m

ÉQUIPE DU PROJET: L-C. TELLIER, tech. V. MERCIER, ing.	DOSIER NO: 601401 C-202.dwg
PRÉPARÉ PAR: B. BRAY, ing.	C-202

EROSION AND SEDIMENT CONTROL

PRE-CONSTRUCTION
PRIOR TO ANY REMOVAL OF SOIL AND CONSTRUCTION:
• INSTALL SILT FENCE (DISTEXTILE) AS NOTED.
• INSTALL PROTECTIVE INSERT OVER ALL EXISTING MANHOLES, CATCHBASINS ADJACENT AND IN CONSTRUCTION ZONE AS FAR BACK FROM TEMPORARY OR PERMANENT INFRASTRUCTURE.
• CONTROL MEASURES TO BE INSPECTED ONCE INSTALLED.
• CONSTRUCTION OF MUD MATS, SEE CONTRACTOR FOR LOCATION.

CONSTRUCTION
• MINIMIZE THE EXTENT OF DISTURBED AREAS.
• PROTECT DISTURBED AREAS OF SOILS.
• PROVIDE COVER (E.G. MULCH) IF DISTURBED AREAS WILL NOT BE REINSTATED WITHIN A REASONABLE PERIOD OF TIME.
• INSPECT SILT FENCE REGULARLY DURING CONSTRUCTION, CLEAN AND REPAIR, AS REQUIRED.
• CONTROL DUST DURING CONSTRUCTION.

AFTER CONSTRUCTION
• PROVIDE PERMANENT COVER TO DISTURBED AREAS (E.G. TOPSOIL AND SEED).
• REMOVE ALL TEMPORARY EROSION AND SEDIMENT CONTROL ITEMS (SILT FENCE AND FILTER CLOTHS) ONCE DISTURBED AREAS HAVE BEEN REINSTATED.

INSPECTIONS
• EROSION AND SEDIMENT CONTROL MEASURES WILL BE INSPECTED UPON COMPLETION.
• CONTROL MEASURES ARE TO BE INSPECTED WEEKLY.

CONTRACTOR TO BE RESPONSIBLE FOR INSTALLATION, INSPECTIONS AND MAINTENANCE OF ALL EROSION AND SEDIMENT CONTROL MEASURES.

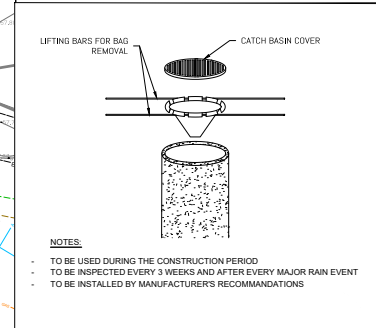

CIVIL ENGINEERING PLANS

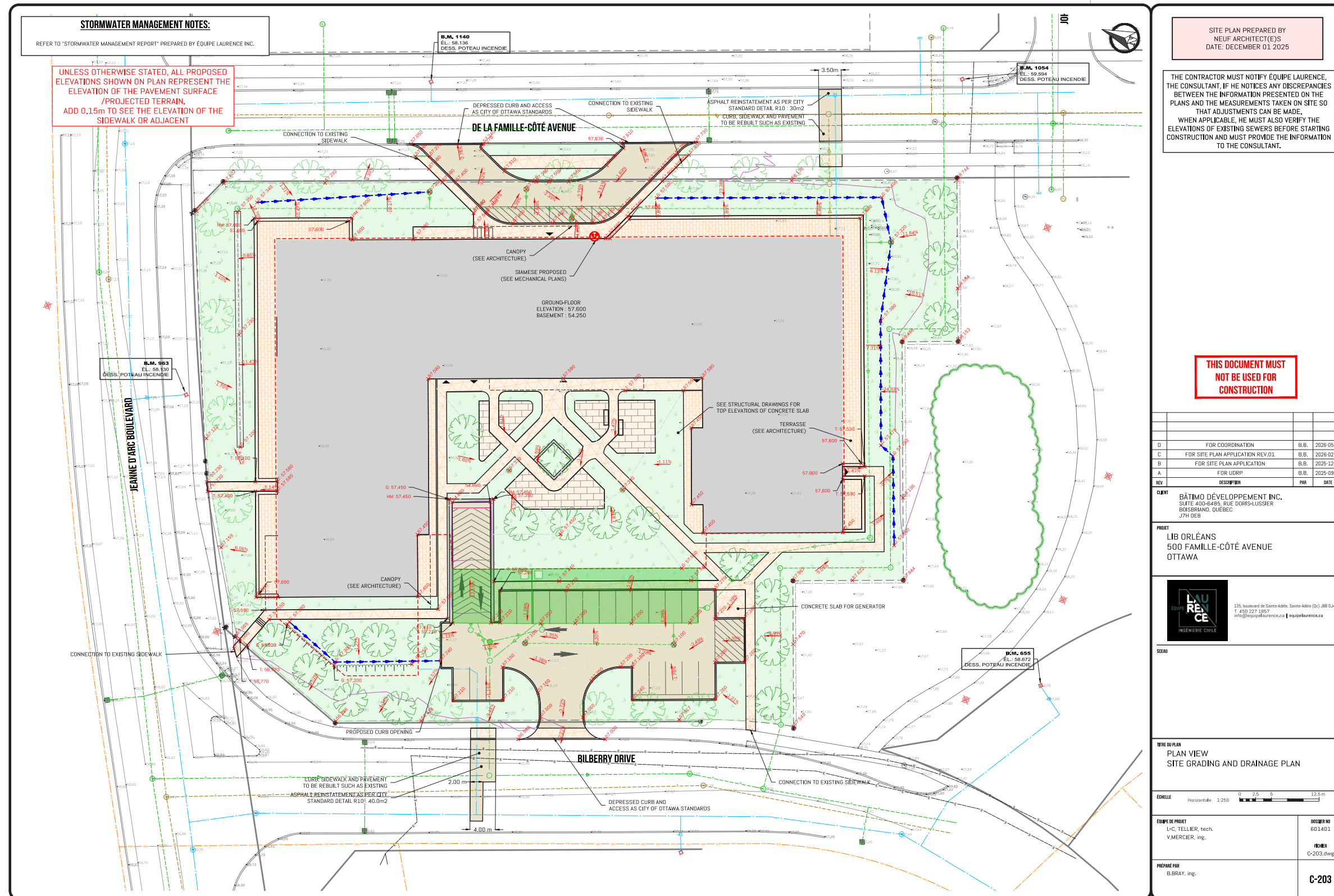

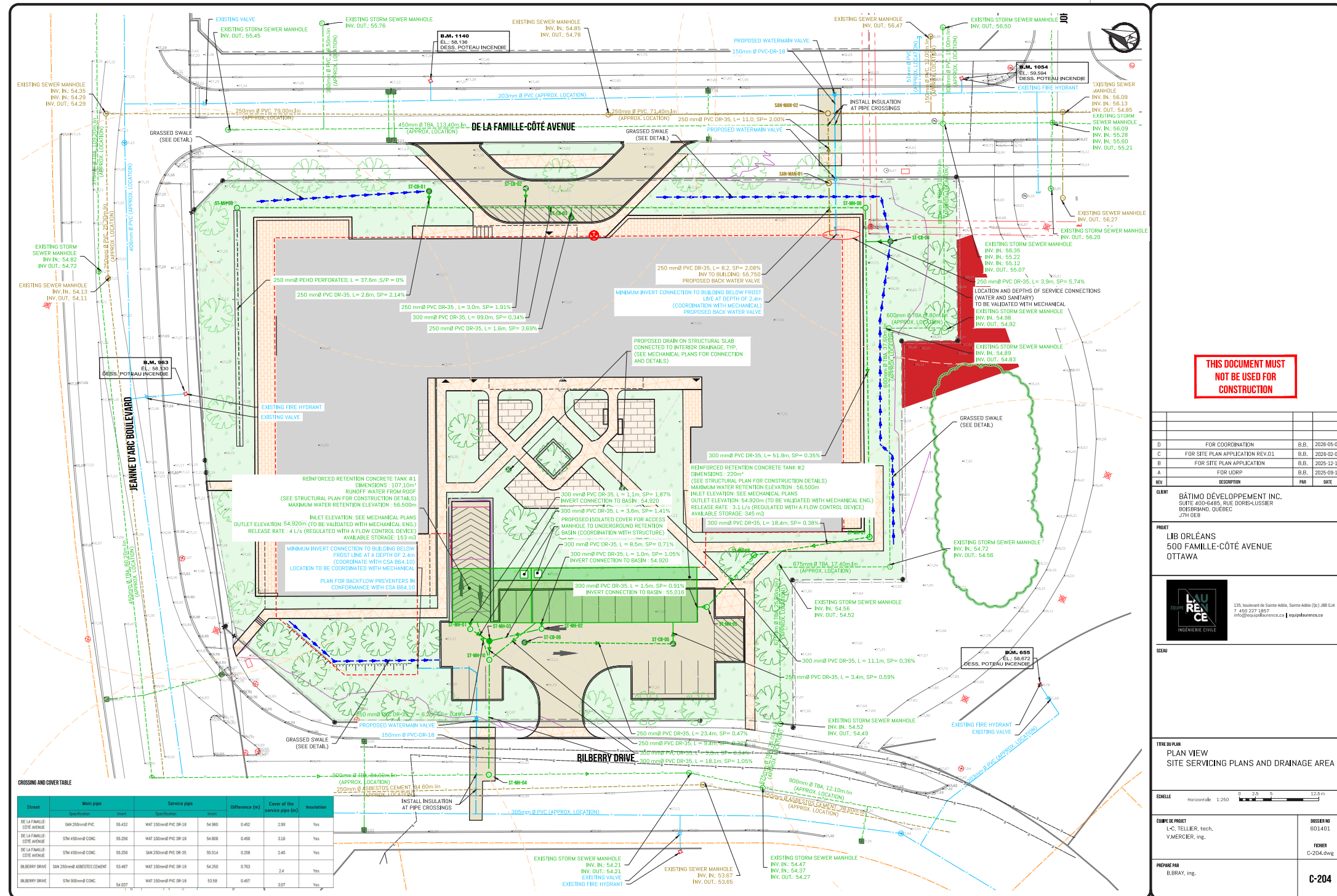

THIS DOCUMENT MUST NOT BE USED FOR CONSTRUCTION

REV	DESCRIPTION	DATE
D	FOR COORDINATION	B.B. 2026-05-08
C	FOR SITE PLAN APPLICATION REV.01	B.B. 2026-02-05
B	FOR SITE PLAN APPLICATION	B.B. 2025-12-11
A	FOR UORP	B.B. 2025-09-25

CLIENT
 BÂTIMO DÉVELOPPEMENT INC.
 SUITE 400-6485 RUE DORIS-LOUSSIER
 BOISBRIAND, QUÉBEC
 J7H 0E8

PROJET
 LIB ORLÉANS
 500 FAMILLE-CÔTÉ AVENUE
 OTTAWA



SCAOU

TITRE DU PLAN
 PLAN VIEW
 SITE SERVICING PLANS AND DRAINAGE AREA

ÉCHELLE
 Horizontale: 1:250

ÉQUIPE DE PROJET
 L.-C. TELLIER, tech.
 V.MERCIER, ing.

PROJETÉ PAR
 B.BRAY, ing.

Dossier no
 601401
Forme
 C-204.png
C-204

STRUCTURES TABLES - STORM WATER		
NAME	TYPE	DETAILS
ST-CB-01	PB-1	TOP: 57.200 (W) 250 mmØ PVC DR-35 INV OUT: 55.640
ST-CB-02	PB-1	TOP: 57.310 (W) 250 mmØ PVC DR-35 INV OUT: 55.590
ST-CB-03	PB-1	TOP: 57.350 (E) 250 mmØ PVC DR-35 INV OUT: 55.540
ST-CB-04	PB-1	TOP: 57.320 (N) 250 mmØ PVC DR-35 INV OUT: 55.550
ST-CB-05	PB-1	TOP: 57.100 (N) 250 mmØ PVC DR-35 INV IN: 55.490 (E) 250 mmØ PVC DR-35 INV OUT: 55.490
ST-CB-06	PB-1	TOP: 57.100 (S) 250 mmØ PVC DR-35 INV OUT: 55.800

STRUCTURES TABLES - SANITARY		
NAME	TYPE	DETAILS
SAN-MAN-01	RC-1200	TOP: 58.015 (W) 250 mmØ PVC DR-35 INV IN: 55.740 (E) 250 mmØ PVC DR-35 INV OUT: 55.690
SAN-MAN-02	RC-1200	TOP: 58.227 (W) 250 mmØ PVC DR-35 INV IN: 55.470 (N) 250 mmØ PVC DR-35 INV IN: 55.420 (S) 250 mmØ PVC DR-35 INV OUT: 55.420

STRUCTURES TABLES - STORM WATER		
NAME	TYPE	DETAILS
ST-MH-01	RC-1200 WITH FLOW REGULATOR	TOP: 57.183 (E) 300 mmØ PVC DR-35 INV IN: 54.900 (S) 300 mmØ PVC DR-35 INV OUT: 54.900
ST-MH-02	RC-1200 WITH FLOW REGULATOR	TOP: 57.169 (E) 300 mmØ PVC DR-35 INV IN: 54.910 (NW) 300 mmØ PVC DR-35 INV OUT: 54.910
ST-MH-03	STORMWATER QUALITY CONTROL SYSTEM WITH 80% TSS REMOVAL	TOP: 57.156 (SE) 300 mmØ PVC DR-35 INV IN: 54.850 (N) 300 mmØ PVC DR-35 INV IN: 54.850 (W) 300 mmØ PVC DR-35 INV OUT: 54.700
ST-MH-04	RC-1600 (EXISTING INVERT TO BE VALIDATED ON SITE)	TOP: 56.896 (E) 300 mmØ PVC DR-35 INV IN: 54.500 (N) 900 mmØ TBA CL-V INV IN: 54.039 (S) 900 mmØ TBA CL-V INV OUT: 54.039
ST-MH-05	RC-915	TOP: 56.817 (E) 300 mmØ PVC DR-35 INV IN: 55.030 (N) 300 mmØ PVC DR-35 INV OUT: 55.030
ST-MH-06	RC-915	TOP: 57.698 (SE) 300 mmØ PVC DR-35 INV IN: 55.070 (W) 300 mmØ PVC DR-35 INV OUT: 55.070
ST-MH-07	RC-915	TOP: 57.593 (E) 300 mmØ PVC DR-35 INV IN: 55.140 (NW) 300 mmØ PVC DR-35 INV OUT: 55.140
ST-MH-08	RC-915	TOP: 57.528 (N) 300 mmØ PVC DR-35 INV IN: 55.320 (W) 300 mmØ PVC DR-35 INV OUT: 55.320
ST-MH-09	RC-915	TOP: 57.261 (W) 250 mmØ PEHD INV IN: 55.770 (S) 300 mmØ PVC DR-35 INV OUT: 55.660
ST-MH-10	RC-1200	TOP: 57.157 (E) 300 mmØ PVC DR-35 INV IN: 54.890 (NE) 250 mmØ PVC DR-35 INV IN: 55.290 (SE) 250 mmØ PVC DR-35 INV IN: 55.290 (W) 300 mmØ PVC DR-35 INV OUT: 54.890

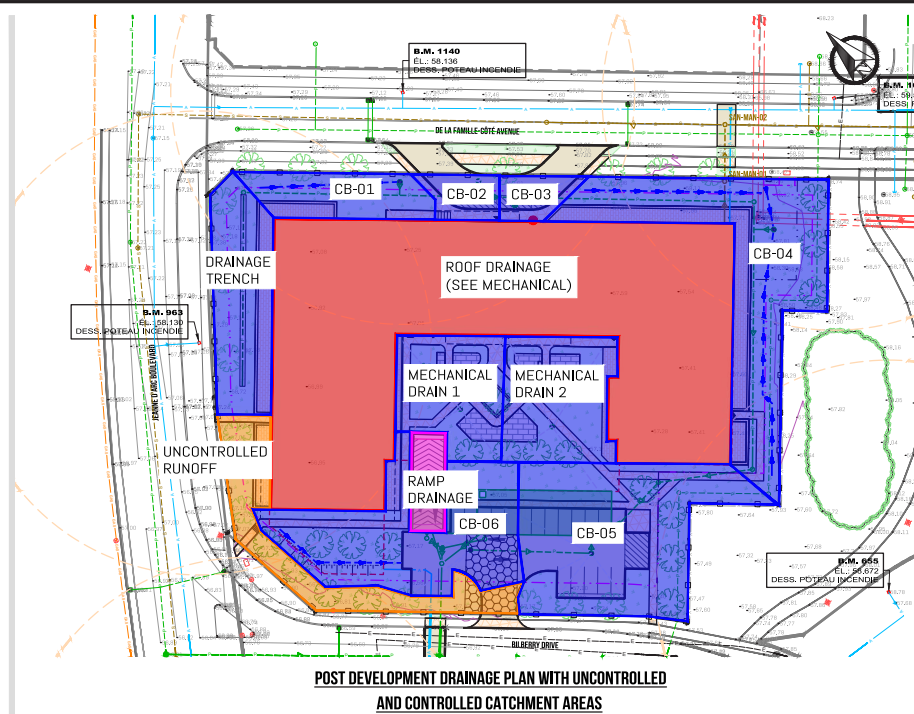

THIS DOCUMENT MUST NOT BE USED FOR CONSTRUCTION

REV	DESCRIPTION	PAR	DATE
D	FOR COORDINATION	B.B.	2026-05-08
C	FOR SITE PLAN APPLICATION REV.01	B.B.	2026-02-05
B	FOR SITE PLAN APPLICATION	B.B.	2025-12-11
A	FOR UDRP	B.B.	2025-09-15

CLIENT
BÂTIMO DÉVELOPPEMENT INC.
SUITE 400-8485, RUE DORVILLE
BOISBRAND, QUÉBEC
J7H 9E9

PROJET
LIB ORLÉANS
500 FAMILLE-CÔTÉ AVENUE
OTTAWA



TITRE DU PLAN
STRUCTURES TABLES AND DETAILS



EQUIPE DE PROJET
L.-C. TELLIER, tech.
V. MERCIER, ing.

PROFANE PAR
B. BRAY, ing.

DOSSIER NO
601401

FICHE
C-205.dwg

C-205

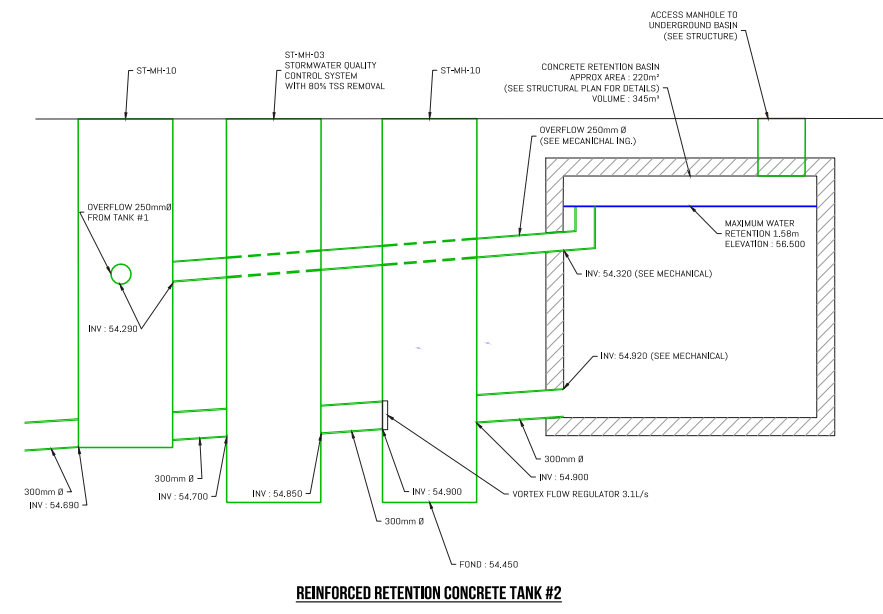
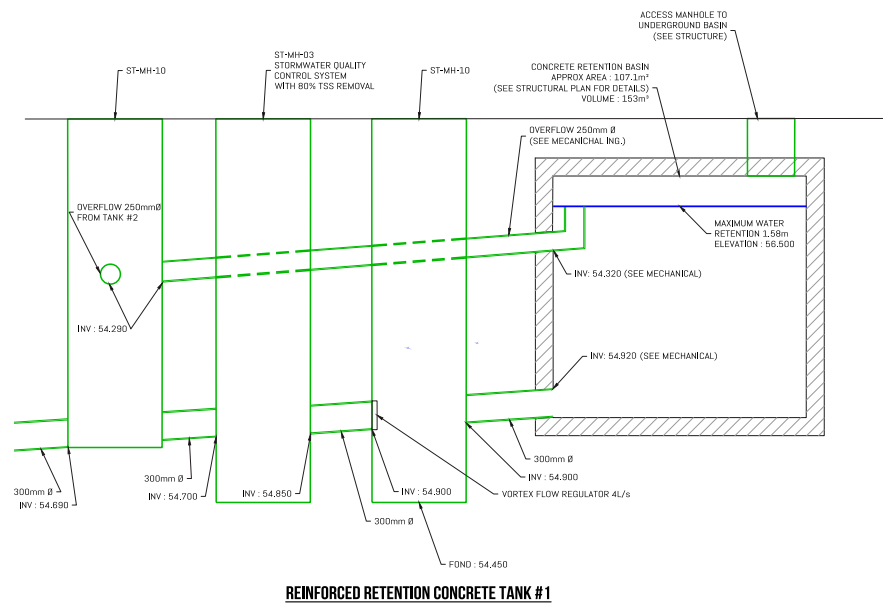

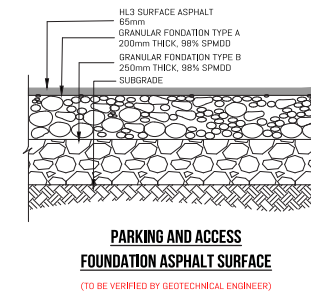
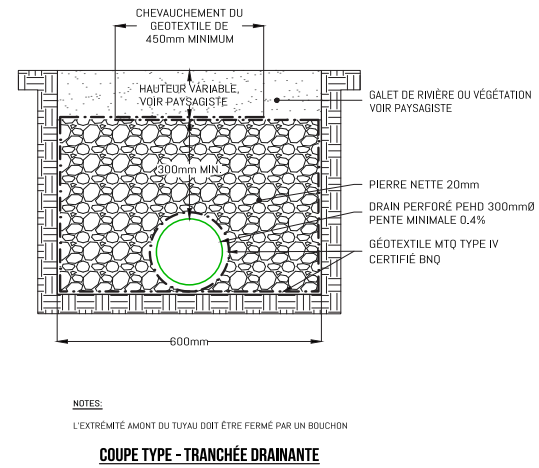
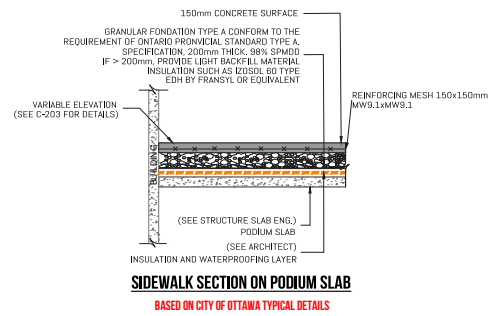

THIS DOCUMENT MUST NOT BE USED FOR CONSTRUCTION

REV	DESCRIPTION	PAR	DATE
D	FOR COORDINATION	B.B.	2025-09-08
C	FOR SITE PLAN APPLICATION REV.01	B.B.	2025-02-05
B	FOR SITE PLAN APPLICATION	B.B.	2025-12-11
A	FOR UDRP	B.B.	2025-09-15

CLIENT
 BÂTIMO DÉVELOPPEMENT INC.
 SUITE 400-8480, RUE DORIS-SUSSEX
 BOISBRAND, QUÉBEC
 J7H 5E9

PROJET
 LIB ORLÉANS
 500 FAMILLE-CÔTÉ AVENUE
 OTTAWA



SCALA

TITRE DU PLAN
 STANDARD SECTIONS AND DETAILS

ÉCHELLE
 AUCUNE ÉCHELLE

ÉQUIPE DE PROJET
 L.-C. TELLIER, tech.
 V. MERCIER, ing.

PRÉPARÉ PAR
 B. BRAY, ing.

DOSSIER NO
 601401
PROJET
 C-207.dwg
C-207

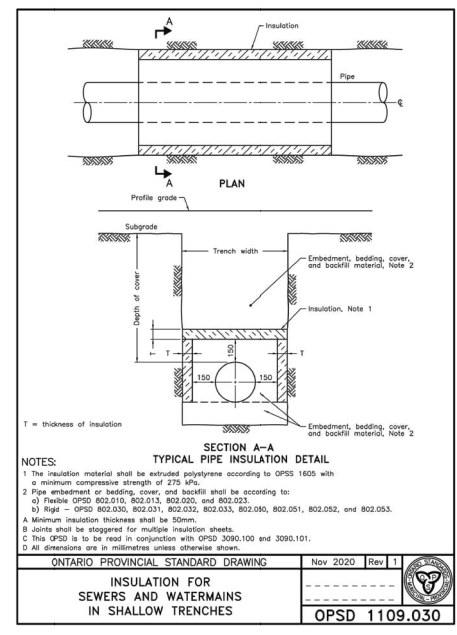

CIVIL ENGINEERING PLANS



THIS DOCUMENT MUST NOT BE USED FOR CONSTRUCTION

REV	DESCRIPTION	PAR	DATE
D	FOR COORDINATION	B.B.	2026-05-08
C	FOR SITE PLAN APPLICATION REV.01	B.B.	2026-02-05
B	FOR SITE PLAN APPLICATION	B.B.	2025-12-11
A	FOR UDRP	S.S.	2025-09-23

CLIENT
 BÂTIMO DÉVELOPPEMENT INC.
 500 FAMILLE-CÔTÉ AVENUE
 BOISBRIAND, QUÉBEC
 J7H 0E8

PROJET
 LIB ORLÉANS
 500 FAMILLE-CÔTÉ AVENUE
 OTTAWA



135 boulevard de Sainte-Adèle, Sainte-Adèle (QC), J8B 1L4
 T. 450.227.1807
 info@neufingenierie.ca | neufingenierie.ca

SCAUX

TITRE DU PLAN
 FIRE HYDRANT COVERAG MAP

ÉCHELLE
 AUCUNE ÉCHELLE

ÉQUIPE DE PROJET
 L.-C. TELLIER, tech.
 V. MERCIER, ing.

DOSSIER NO
 601401

PROJET PAR
 BLBRAY, ing.

PROJET
 C-208

PROPOSED LANDSCAPE PLAN

KEY	QTY	BOTANICAL NAME	COMMON NAME	SIZE	CONDITION	REMARKS	OWNERSHIP	COMMENTS
1	1	Acer ginnale	Amur Maple	50mm dbh	DEAD	TO BE REMOVED	500 Famille-Côte Ave	
2	1	Acer ginnale	Amur Maple	50mm dbh	GOOD	TO REMAIN	500 Famille-Côte Ave	
3	1	Acer ginnale	Amur Maple	50mm dbh	GOOD	TO BE REMOVED	500 Famille-Côte Ave	In conflict with parking lot entrance
4	1	Amelelancher canadensis	Shadblow Serviceberry	50mm dbh	POOR	TO BE REMOVED	500 Famille-Côte Ave	In conflict with parking lot entrance
5	1	Amelelancher canadensis	Shadblow Serviceberry	50mm dbh	GOOD	TO REMAIN	500 Famille-Côte Ave	In conflict with parking spaces
6	1	Amelelancher canadensis	Shadblow Serviceberry	50mm dbh	GOOD	TO REMAIN	500 Famille-Côte Ave	In conflict with parking spaces
7	1	Acer saccharinum	Silver Maple	450mm dbh	GOOD	TO BE REMOVED	500 Famille-Côte Ave	In conflict with proposed building
8	1	Acer saccharinum	Silver Maple	500mm dbh	GOOD	TO REMAIN	500 Famille-Côte Ave	
9	1	Acer saccharinum	Silver Maple	450mm dbh	GOOD	TO REMAIN	500 Famille-Côte Ave	
10	1	Acer saccharinum	Silver Maple	450mm dbh	GOOD	TO REMAIN	500 Famille-Côte Ave	
11	1	Acer saccharinum	Silver Maple	500mm dbh	GOOD	TO REMAIN	500 Famille-Côte Ave	
12	1	Amelelancher canadensis	Shadblow Serviceberry	50mm dbh	GOOD	TO REMAIN	City of Ottawa	
13	1	Amelelancher canadensis	Shadblow Serviceberry	50mm dbh	GOOD	TO REMAIN	City of Ottawa	
14	1	Amelelancher canadensis	Shadblow Serviceberry	50mm dbh	GOOD	TO REMAIN	City of Ottawa	
15	1	Amelelancher canadensis	Shadblow Serviceberry	50mm dbh	GOOD	TO BE REMOVED	City of Ottawa	
16	1	Tilia cordata	Little-Leaf Linden	50mm dbh	POOR	TO BE REMOVED	City of Ottawa	Leafy branch
17	1	Tilia cordata	Little-Leaf Linden	50mm dbh	POOR	TO BE REMOVED	City of Ottawa	Leafy branch
18	1	Tilia cordata	Little-Leaf Linden	50mm dbh	POOR	TO BE REMOVED	City of Ottawa	Leafy branch
19	1	Tilia cordata	Little-Leaf Linden	50mm dbh	POOR	TO REMAIN	City of Ottawa	
20	1	Gleditsia triacanthos	Honey Locust	50mm dbh	GOOD	TO REMAIN	City of Ottawa	
21	1	Gleditsia triacanthos	Honey Locust	50mm dbh	POOR	TO BE REMOVED	City of Ottawa	
22	1	Gleditsia triacanthos	Honey Locust	50mm dbh	DEAD	TO BE REMOVED	City of Ottawa	

GENERAL NOTES:

- IT IS THE RESPONSIBILITY OF THE APPROPRIATE CONTRACTOR OR OFFICIAL TO REPORT ANY ERRORS, OMISSIONS OR DISCREPANCIES ON THIS PLAN WITH ACTUAL SITE CONDITIONS TO THE LANDSCAPE ARCHITECT BEFORE PROCEEDING WITH CONSTRUCTION.
- THE CONTRACTOR IS TO NOTIFY ALL UTILITY COMPANIES AND AUTHORITIES PRIOR TO ANY EXCAVATION AND ASCERTAIN LOCATIONS OF UNDERGROUND SERVICES.
- THE CONTRACTOR IS TO REINSTATE ALL AREAS AND ITEMS DAMAGED AS A RESULT OF CONSTRUCTION ACTIVITY.
- THE CONTRACTOR IS TO COMPLY WITH ALL PERTINENT CODES AND BY-LAWS.
- THE CONTRACTOR IS TO MAINTAIN A POSITIVE SURFACE RUN-OFF THROUGHOUT THE ENTIRE CONSTRUCTION PERIOD.
- THE LANDSCAPE ARCHITECT IS NOT RESPONSIBLE FOR SUBSURFACE CONDITIONS.
- THE CONTRACTOR IS TO IDENTIFY ALL EXISTING TREES TO REMAIN ON SITE WITH THE LANDSCAPE ARCHITECT PRIOR TO CONSTRUCTION.
- THE CONTRACTOR IS TO STAKE THE PROPOSED LOCATION OF ALL PLANT MATERIAL IN CONJUNCTION WITH THE LANDSCAPE ARCHITECT PRIOR TO EXCAVATION.
- MINIMUM DISTANCES FOR SELECTED DECIDUOUS TREES ARE AS FOLLOWS:
 - 9.1. BUILDING FOUNDATIONS - 7.5M
 - 9.2. SIDEWALKS - 1.5M
 - 9.3. PUBLIC STREETS - 2.5M
 - 9.4. UNDERGROUND INFRASTRUCTURE - 2.0M
- ALL TREES WITHIN 1M OF UNDERGROUND UTILITY TRENCHES ARE TO BE EXCAVATED BY HAND.
- REMOVE ALL PROTECTIVE WRAPPING FROM TREE TRUNKS AFTER INSTALLATION.
- STAKING OF TREES SHALL ONLY BE PERFORMED IF NECESSARY.
- ENSURE THAT MULCH IS PULLED BACK A MINIMUM DISTANCE OF 75MM FROM BASE OF TREE TRUNK.



LEGAL DESCRIPTION:
 BLOCK 6
 REGISTERED PLAN 4M-1682
 CITY OF OTTAWA
 SURVEYED BY ANNIS, O'SULLIVAN, VOLLEBEKK LTD.

PROPOSED PLANT LIST						
KEY	QTY	BOTANICAL NAME	COMMON NAME	SIZE	CONDITION	REMARKS
TREES						
AL	2	Amelelancher laevis 'Spring Flurry'	Spring Flurry Serviceberry	50mm ø	B&B	Native
AF	2	Acer x freemanii	Freeman's Maple	50mm ø	B&B	
AG	1	Acer ginnale	Amur Maple	50mm ø	B&B	Native
AO	1	Celtis occidentalis	Hickory	50mm ø	B&B	
GD	3	Gleditsia triacanthos var. inermis 'Draven'	Street Keeper Honeylocust	50mm ø	B&B	
GT	4	Gleditsia triacanthos	Honey Locust	50mm ø	B&B	Native to S. Ont.
PD	1	Pinus glauca	White Spruce	2000mm ht.	B&B	Native
TA	3	Tilia americana	Basswood	50mm ø	B&B	
SHRUBS						
AH	24	Hydrangea arborescens 'Annabelle'	Annabelle Hydrangea	3 gal. pot	Potted	Space 1000mm o.c.
BB	16	Euroyrium alatum 'Compactus'	Burning Bush	800 mm ht.	Potted	Space 1200mm o.c.
CP	5	Syringa vulgaris	Common Purple Lilac	1200 mm ht.	Potted	Space 2000mm o.c.
JH	88	Juniperus horizontalis 'Andora Compacta'	Compact Andora Juniper	600 mm spr.	Potted	Space 1200mm o.c.
JV	11	Juniperus virginiana	Eastern Red Cedar	3 gal pot	Potted	Native
RA	47	Rhus aromatica 'Sola-Lux'	Grow Low Fragrant Sumac	500 mm ht.	Potted	Space 1000mm o.c. Native
RR	26	Rosa rugosa	Rugosa Rose	800 mm ht.	Potted	Space 1000mm o.c.
SF	42	Sorbaria sorbifolia 'Sem'	Sem Fall Spice	800 mm ht.	Potted	Space 1000mm o.c.
SS	41	Sorbaria sorbifolia	Ural False Spirea	800 mm ht.	Potted	Space 1200mm o.c.
SV	35	Spiraea x vanhouttei	Bridalweath Spirea	800 mm ht.	Potted	Space 1200mm o.c.
ORNAMENTAL GRASSES AND PERENNIALS						
KF	91	Calamagrostis 'Karl Foerster'	Feather Reed Grass	250mm pot	Potted	Space 1000mm o.c.
OD	119	Calamagrostis 'Overstar'	Overstar Grass	250mm pot	Potted	Space 1000mm o.c.

NOTE: ALL PLANT MATERIAL IS PROPOSED ON PRIVATE PROPERTY

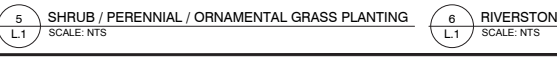
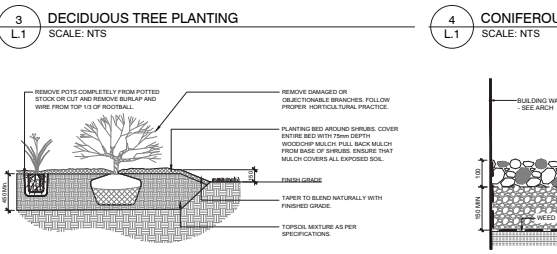
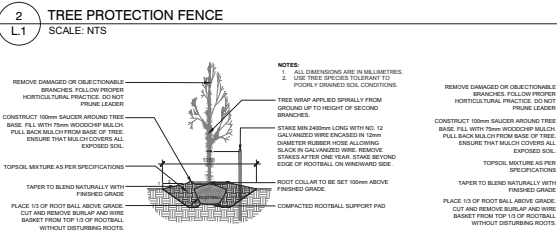
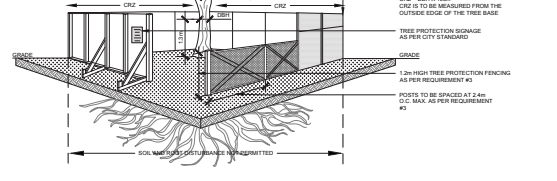
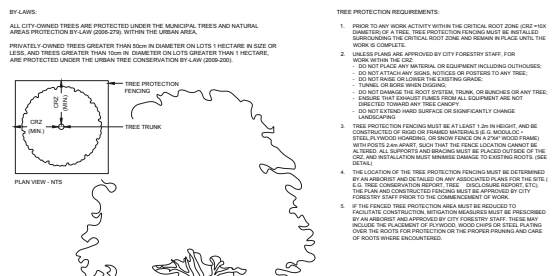
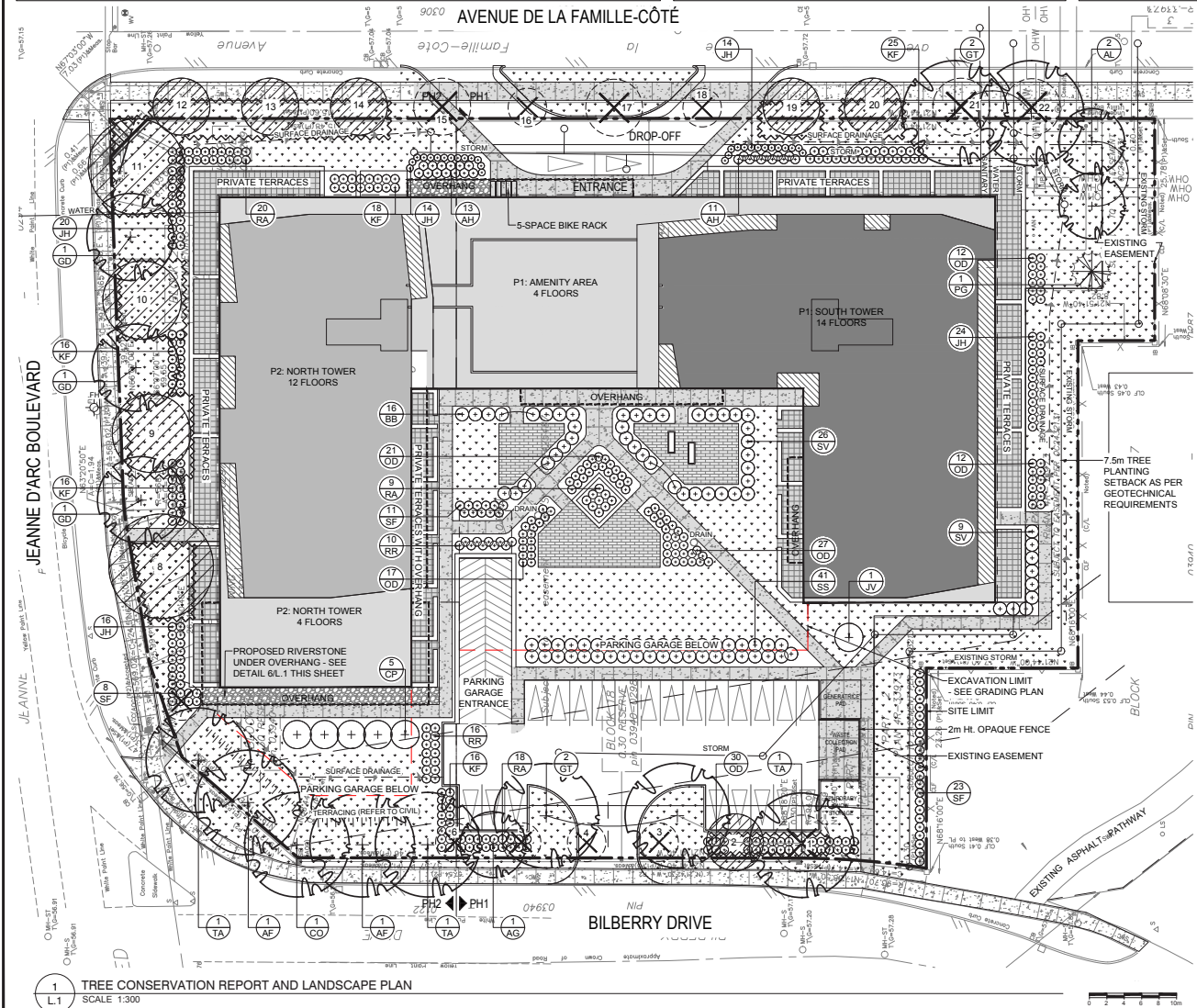

TREE PLANTING NOTES:

- ALL TREES ARE PROPOSED ON PRIVATE PROPERTY.
- PROPOSED TREES SPACING: MIN. 7m O.C.
- ALL TREES PROPOSED WITH A SOIL DEPTH OF 1.5m.
- THE LANDSCAPE PLAN WAS PREPARED IN CONJUNCTION WITH THE GEOTECHNICAL INVESTIGATION (PATTERSON, REPORT P08058-MEMO 01, June 1, 2025).
- SOIL VOLUME REQUIREMENTS:

TREE TYPE / SIZE	SINGLE TREE SOIL VOLUME (m³)	MULTIPLE TREE SOIL VOLUME (m³/row)
Ornamental / column	15	9
Small	20	12
Medium / conifer	25	15
Large	30	18

40 YEAR CANOPY CALCULATION:

- 8949m² SITE AREA
- 3 CONIFEROUS TREES PROPOSED (20m² ea.)
- 3 SMALL DECIDUOUS TREES PROPOSED (16m² ea.)
- 3 MEDIUM DECIDUOUS TREES PROPOSED (17m² ea.)
- 10 LARGE DECIDUOUS TREES PROPOSED (177m² ea.)
- EXISTING TREE CANOPY COVER TO REMAIN: 349m²
- 2424m² or 27.1% CANOPY COVER
- Large deciduous tree calculated at 15m spread.
- Medium deciduous tree calculated at 10m spread.
- Small deciduous tree calculated at 4.5m spread. Conifer tree calculated at 5m spread.

CLIENT
 emobatimo

CONSULTANTS
 SUPERVISORS
 ANNIS, O'SULLIVAN, VOLLEBEKK LTD.

ARCHITECTS
 NEUF ARCHITECTES

ENGINEERS
 REVE

LEGEND

- EXISTING TREE TO REMAIN
- EXISTING TREE TO BE REMOVED
- PROPOSED DECIDUOUS TREE
- PROPOSED CONIFEROUS TREE
- PROPOSED SHRUBS, PERENNIALS AND ORNAMENTAL GRASSES
- PROPOSED SOIL
- PROPOSED PRECAST CONCRETE PAVERS TYPE 1
- PROPOSED PRECAST CONCRETE PAVERS TYPE 2
- PROPOSED RIVERSTONE
- PROPOSED TREE PROTECTION FENCE
- PROPERTY LINE

No.	Issue	Date	By	Check
6	ISSUED FOR SPA	06/12/2025	WF	JL
5	ISSUED FOR SPA	04/02/2025	ML	JL
4	ISSUED FOR DISCUSSION AND REVIEW	11/12/2025	WF	JL
3	ISSUED FOR DISCUSSION AND REVIEW	13/10/2025	WF	JL
2	REVISED AS PER COMMENTS	12/09/2025	CAT	JL
1	ISSUED FOR REVIEW	09/09/2025	CAT	JL
No.	Issue	Date	By	Check

JAMES B. LENNOX & ASSOCIATES INC.
 LANDSCAPE ARCHITECTS
 5152 CAMELING AVE. OTTAWA, ONTARIO K1H 5A8
 TEL: (416) 733-9148 FAX: (416) 643-3942

PROJECT
 LIB ORLEANS
 500 Famille-Côte Ave, Orléans, ON K1C 2C2

DRAWING
 TREE CONSERVATION REPORT AND LANDSCAPE PLAN

STAMP
 ASSOCIATION OF PROFESSIONAL LANDSCAPE ARCHITECTS OF ONTARIO

SCALE
 AS SHOWN

START DATE
 SEPTEMBER, 2025

PROJECT NO.
 25MS2550

DRAWING NO.
 L.1

PLOT SIZE
 ARCH-D

APPENDIX

BOUNDARIES OF THE AREAS

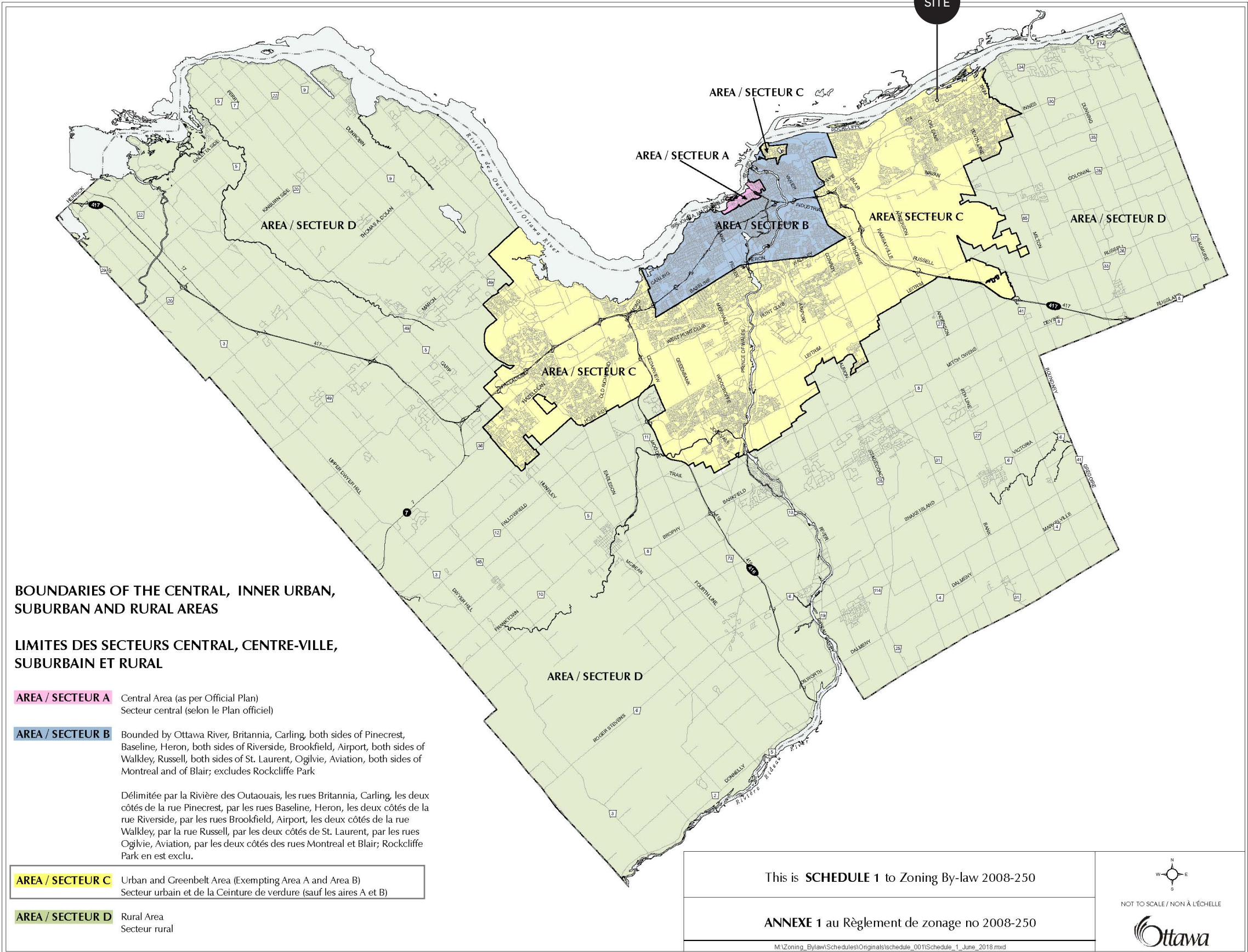

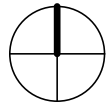

SCHEDULE 1A

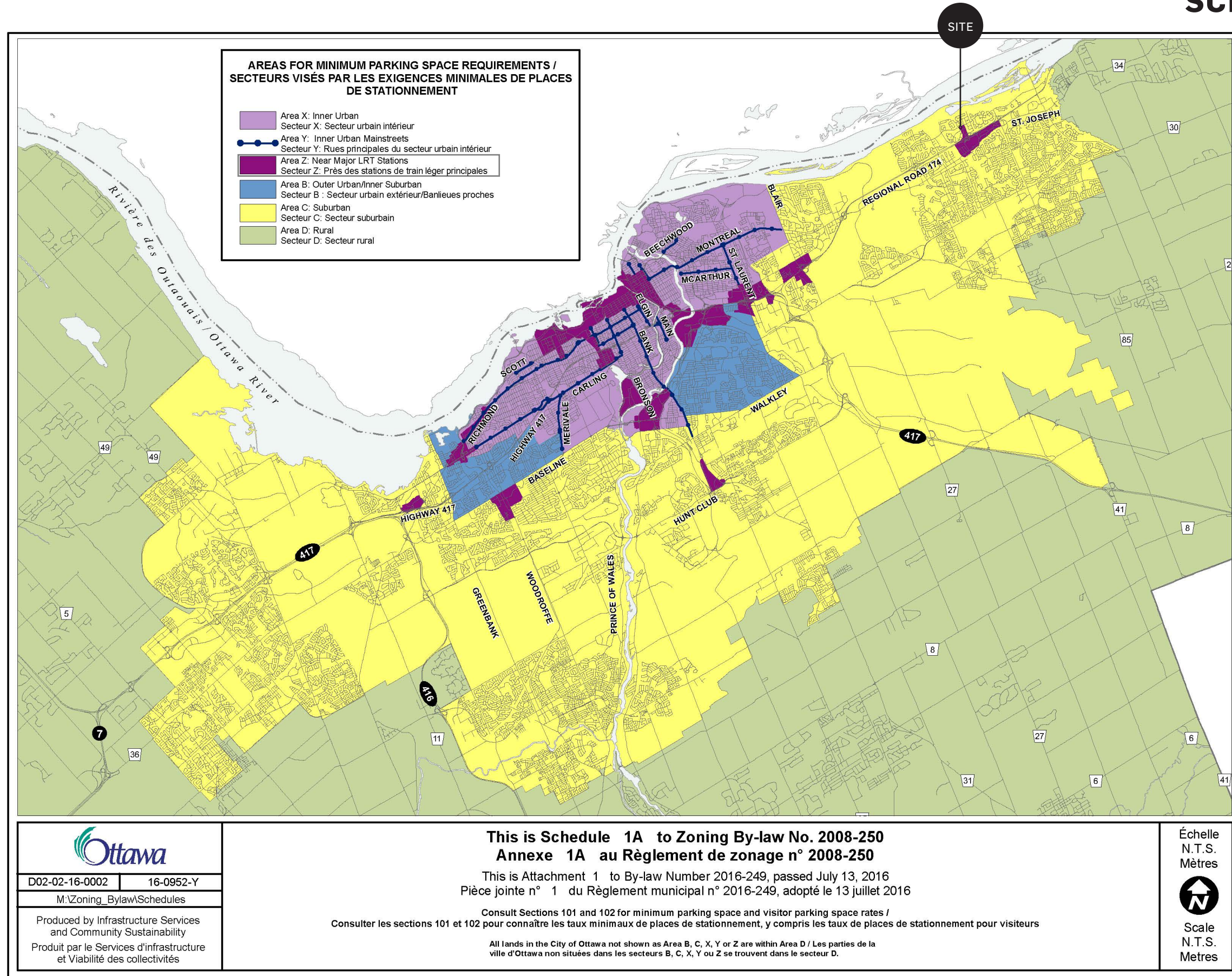

Ottawa

D02-02-16-0002	16-0952-Y
M:\Zoning_Bylaw\Schedules	

Produced by Infrastructure Services and Community Sustainability
Produit par le Services d'infrastructure et Viabilité des collectivités

**This is Schedule 1A to Zoning By-law No. 2008-250
Annexe 1A au Règlement de zonage n° 2008-250**

This is Attachment 1 to By-law Number 2016-249, passed July 13, 2016
Pièce jointe n° 1 du Règlement municipal n° 2016-249, adopté le 13 juillet 2016

Consult Sections 101 and 102 for minimum parking space and visitor parking space rates /
Consulter les sections 101 et 102 pour connaître les taux minimaux de places de stationnement, y compris les taux de places de stationnement pour visiteurs

All lands in the City of Ottawa not shown as Area B, C, X, Y or Z are within Area D / Les parties de la ville d'Ottawa non situées dans les secteurs B, C, X, Y ou Z se trouvent dans le secteur D.

Échelle
N.T.S.
Mètres

Scale
N.T.S.
Metres

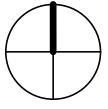

Property Report

Select a parcel on the map or search for an address to see a report for that property. Zoom in on the map if the property parcels are not visible.

Parcelle de propriété :

Superficie calculée de la parcelle⁽¹⁾: 8948.20 m²
(96317.49 pi²) (0.89 ha)

Adresse principale :

500 av de la Famille-Côté

Collecte des déchets solides :

Entrepreneur chargé de la collecte : City

Zone : 5

Jour/calendrier de collecte : FRIDAY/B

Calendrier de collecte des déchets et des matières à recycler

Information sur le quartier :

Numéro : 2

Nom du quartier : Orléans-Ouest-Innes

Nom du conseiller municipal : Laura Dudas

Pour en savoir plus sur Laura Dudas

Imprimer le rapport

Photo aérienne de la propriété

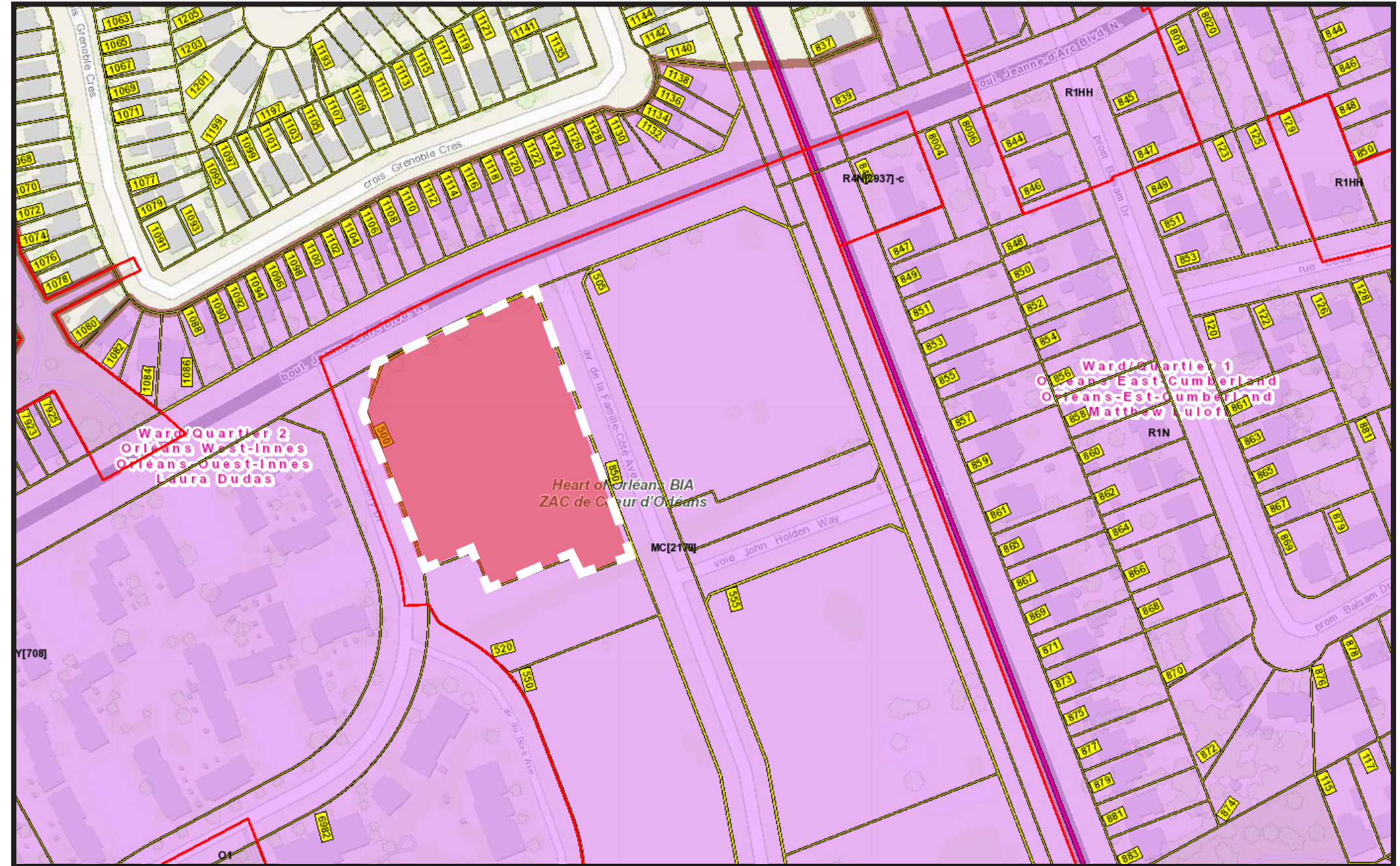

ZONING GRID - MC

Selected address: 500 Famille-Côté Ave
Ward: Ward 2, Orléans West-Innes

	Existing Zoning (By-law 2008-250)	New Zoning (By-law 2026-50) Draft 2
Zone code	MC[2179]	H2[2179]
Legend grouping	Mixed Use - Commercial Zones II	Hub Zones
Zoning overlays		

TABLE 191 - MC ZONE PROVISIONS

I ZONING MECHANISMS	II PROVISIONS	
(a) Minimum lot area	No minimum	
(b) Minimum lot width	No minimum	
(c) Minimum front yard and corner side yard setback	(i) abutting a lot in a residential zone	3 m
	(ii) abutting the rapid transit corridor	2 m
	(iii) other cases	No minimum
(d) Minimum interior side yard setback	(i) abutting a lot in a residential zone	3 m
	(ii) abutting the rapid transit corridor	2 m
	(iii) other cases	No minimum
(e) Minimum rear yard setback	(i) rear lot line abutting a lot in a residential zone	6 m
	(ii) abutting the rapid transit corridor	2 m
	(iii) other cases	No minimum
(f) Maximum floor space index	No maximum; unless otherwise shown on the zoning map	
(g) Minimum building height	(i) for all uses within 400 metres of a rapid transit station, other than a gas bar where it is permitted by an exception	6.7 m

	(ii) other cases	No minimum
(h) Maximum building heights	(i) in any area up to and including 20 metres from a property line abutting a R1, R2, R3 or R4 zone (By-law 2011-124)	11 m
	(ii) in any area over 20 metres and up to and including 30 metres from a property line abutting a R1, R2, R3 or R4 residential zone (By-law 2011-124)	20 m
	(iii) in all other cases	No maximum, or as shown by the suffix "H", on a zoning map, or specified in a subzone or exception where applicable
(i) Minimum width of landscaped area		No minimum, except that where a yard is provided and not used for required driveways, aisles, parking, loading spaces or outdoor commercial patio, the whole yard must be landscaped

ZONING GRID - H2

Selected address: 500 Famille-Côté Ave
 Ward: Ward 2, Orléans West-Innes

	Existing Zoning (By-law 2008-250)	New Zoning (By-law 2026-50) Draft 2
Zone code	MC[2179]	H2[2179]
Legend grouping	Mixed Use - Commercial Zones II	Hub Zones
Zoning overlays		

Table 902 – Hub Zone 2 Provisions		
Zoning Mechanism	Provisions	
(a) Minimum lot area (m ²)	No minimum	
(b) Minimum lot width (m)	No minimum	
(c) Minimum front and exterior side yard setback (m)	For any part of the building greater than 15m above grade: 1.5	
(d) Minimum interior side yard setbacks (m)	(i) Where abutting lands zoned N1-N6 – Neighbourhood	3
	(ii) Where abutting a rapid transit corridor	2
	(iii) In all other cases	No minimum
(e) Minimum rear yard setback (m)	(i) When abutting lands zoned N1-N6 – Neighbourhood	6
	(ii) When abutting a rapid transit corridor	2
	(iii) In all other cases	No minimum
(f) Minimum building height (m)	(i) In Area A of Schedule A1 -- Transects:	15
	(ii) In Area B and C of Schedule A1 – Transects:	11
(h) Maximum building heights (m)	(i) For any area up to and including 30m from a lot No part of a building may project above a	

	line abutting a N1, N2, N3 or N4 zone:	45 degree angular plane measured from a height of 15 metres above any lot line shared with an abutting N1-N4 zoned lot
	(ii) For any area greater than 30m away from a lot line abutting a N1, N2, N3 or N4 zone, or where the lot does not abut a N1, N2, N3 or N4 zone	132, unless otherwise specified by a H suffix, schedule, or exception.

SURVEYOR PLAN | 4M-1682

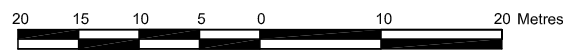
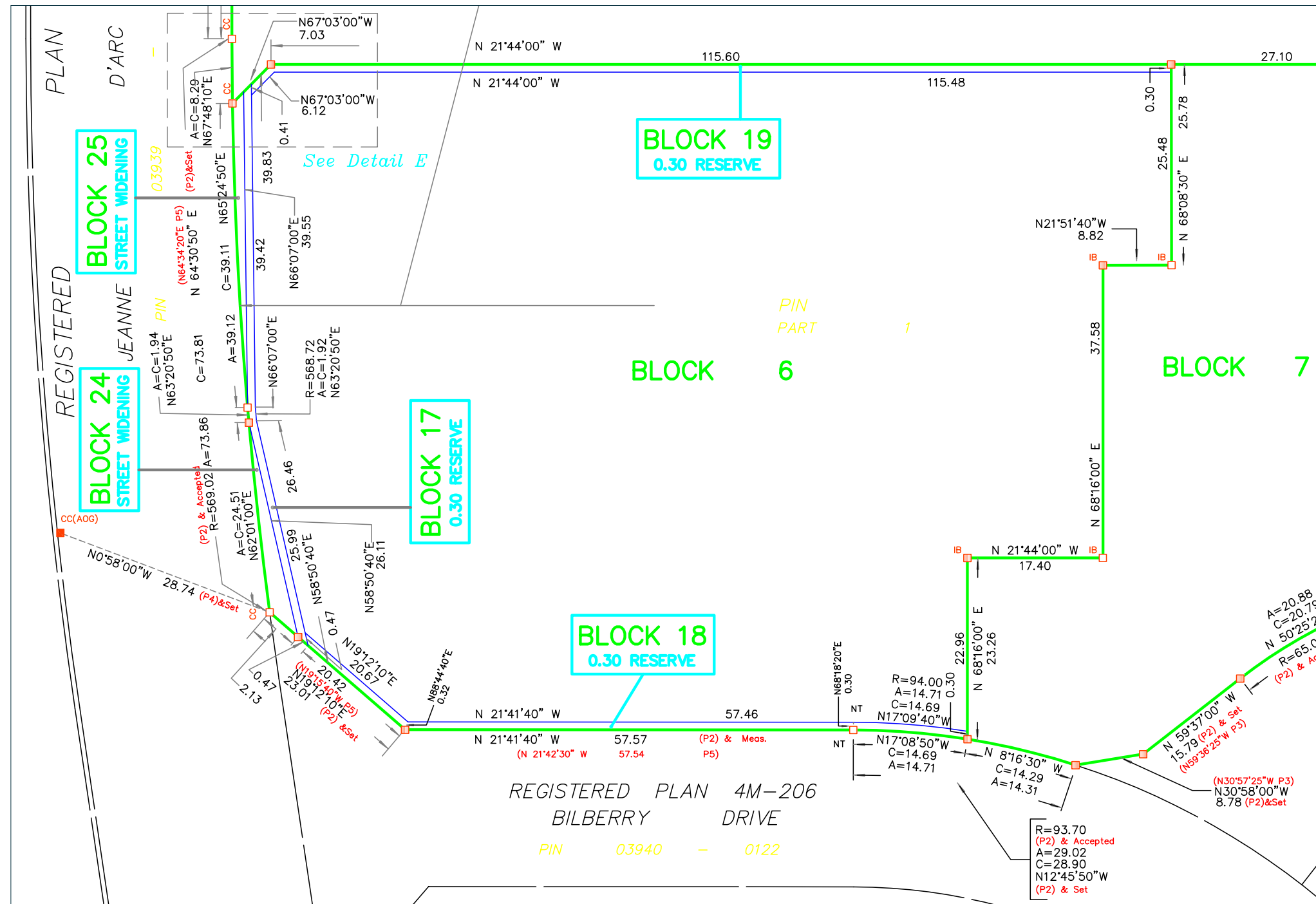
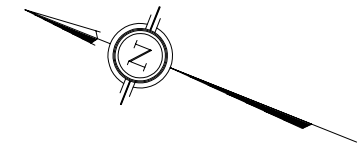

NOTES AND LEGEND

—□—	denotes	Survey Monument Planted.
—■—	"	Survey Monument Found
SIB	"	Standard Iron Bar.
SSIB	"	Short Standard Iron Bar.
CC	"	Cut Cross.
IB	"	Iron Bar.
CLF	"	Chain Link Fence
BF	"	Board Fence
SW	"	Stone Wall
(AOG)	"	Annis, O'Sullivan, Vollebek Ltd.
(WIT)	"	Witness
NT	"	Not Tangential
(P1)	"	Plan 4R-7075
(P2)	"	Plan 4R-16870
(P3)	"	Carleton Condominium Plan 330
(P4)	"	(AOG) Coordinate File, Reference 16497-16
(P5)	"	Registered Plan M-206

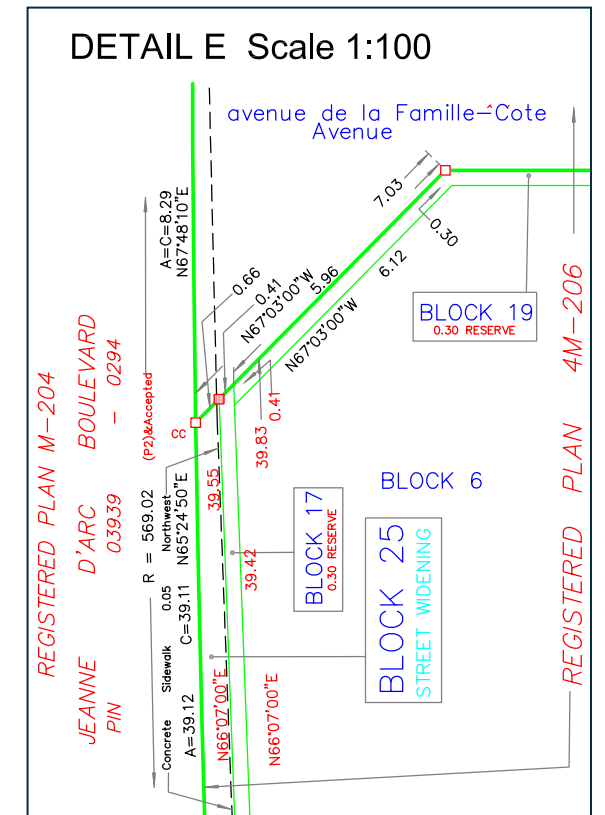

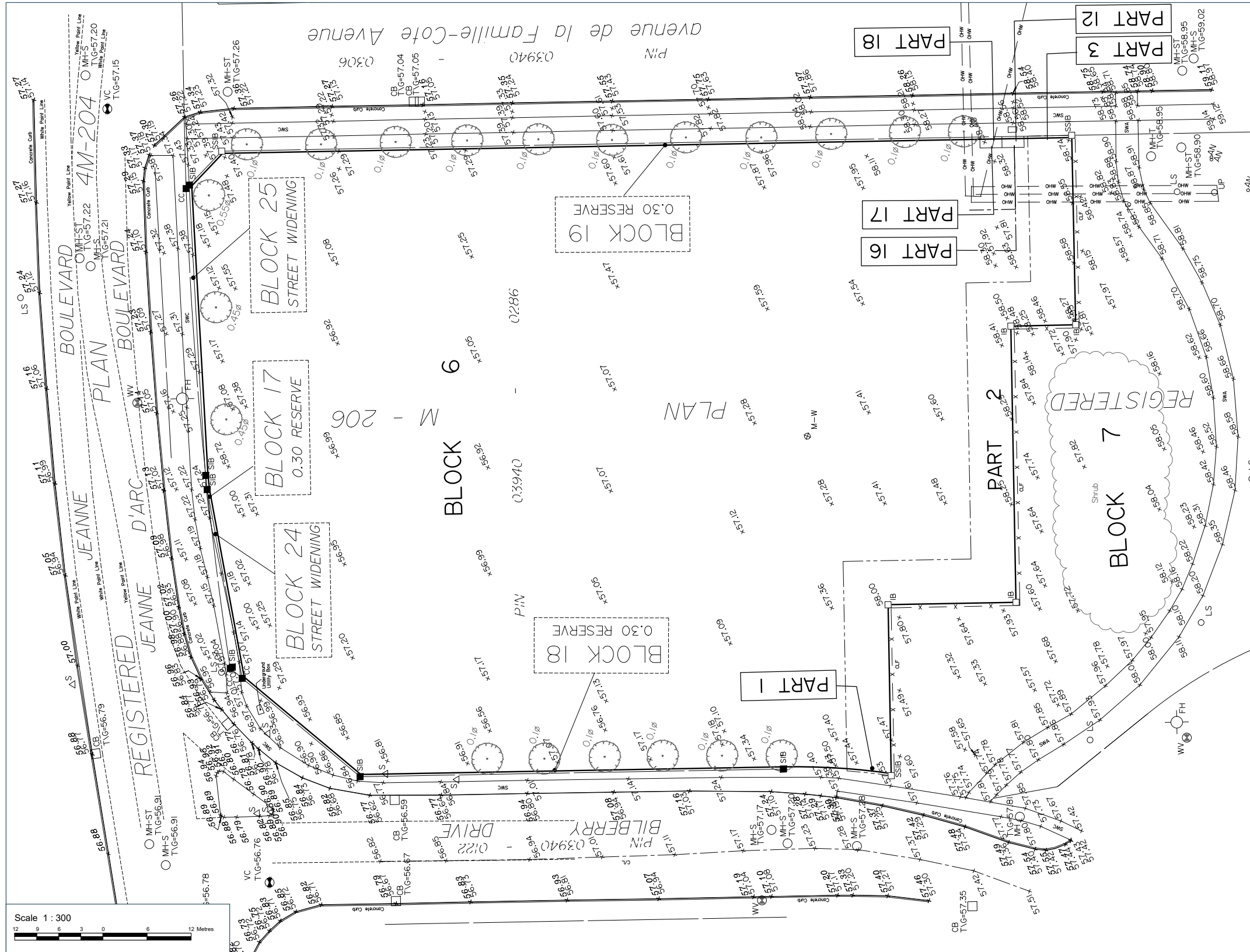
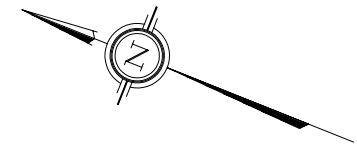

Notes & Legend

- Survey Monument Planted
- Survey Monument Found
- SIB Standard Iron Bar
- SSIB Short Standard Iron Bar
- IB Iron Bar
- CC Cut Cross
- CP Concrete Pin
- IB# Round Iron Bar
- SBW Spike & Washer
- SSIB* Short Standard Iron Bar (0.3 Long)
- IB* Iron Bar (0.3 Long)
- IP Iron Pipe
- RPL Rock Plug
- NW Nail & Washer
- (WIT) Witness
- Meas. Measured
- MH-ST Maintenance Hole (Storm Sewer)
- MH-S Maintenance Hole (Sanitary)
- MH-T Maintenance Hole (Traffic)
- MH Maintenance Hole (Unidentified)
- ⊙ VC Valve Chamber (Watermain)
- OHW Overhead Wires
- UP Utility Pole
- AN Anchor
- LS Light Standard
- CB Catch Basin
- FH Fire Hydrant
- ⊙ WV Water Valve
- T/G Top of Grate
- △ s Sign
- CLF Chain Link Fence
- SWA Asphalt Sidewalk
- SWC Concrete Sidewalk
- M-W Monitoring Well
- ∅ Diameter
- 65.00 Location of Elevations
- 66.00 Top of Concrete Curb Elevation
- C/L Centreline
- Property Line
- Deciduous Tree
- Shrub

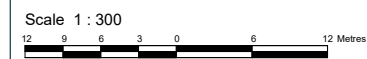

PROPOSED BLOCK PLAN

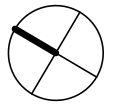

LEGEND

- RESIDENTIAL MID-DENSITY (R4M)
- RESIDENTIAL LOW DENSITY (TOWNHOUSES R3Y)
- RESIDENTIAL LOW DENSITY (SINGLE DETACHED R1N)
- MIXED USE/COMMERCIAL (MC)
- PROPERTY BOUNDARY
- SETBACKS

0 25m 50m 100m

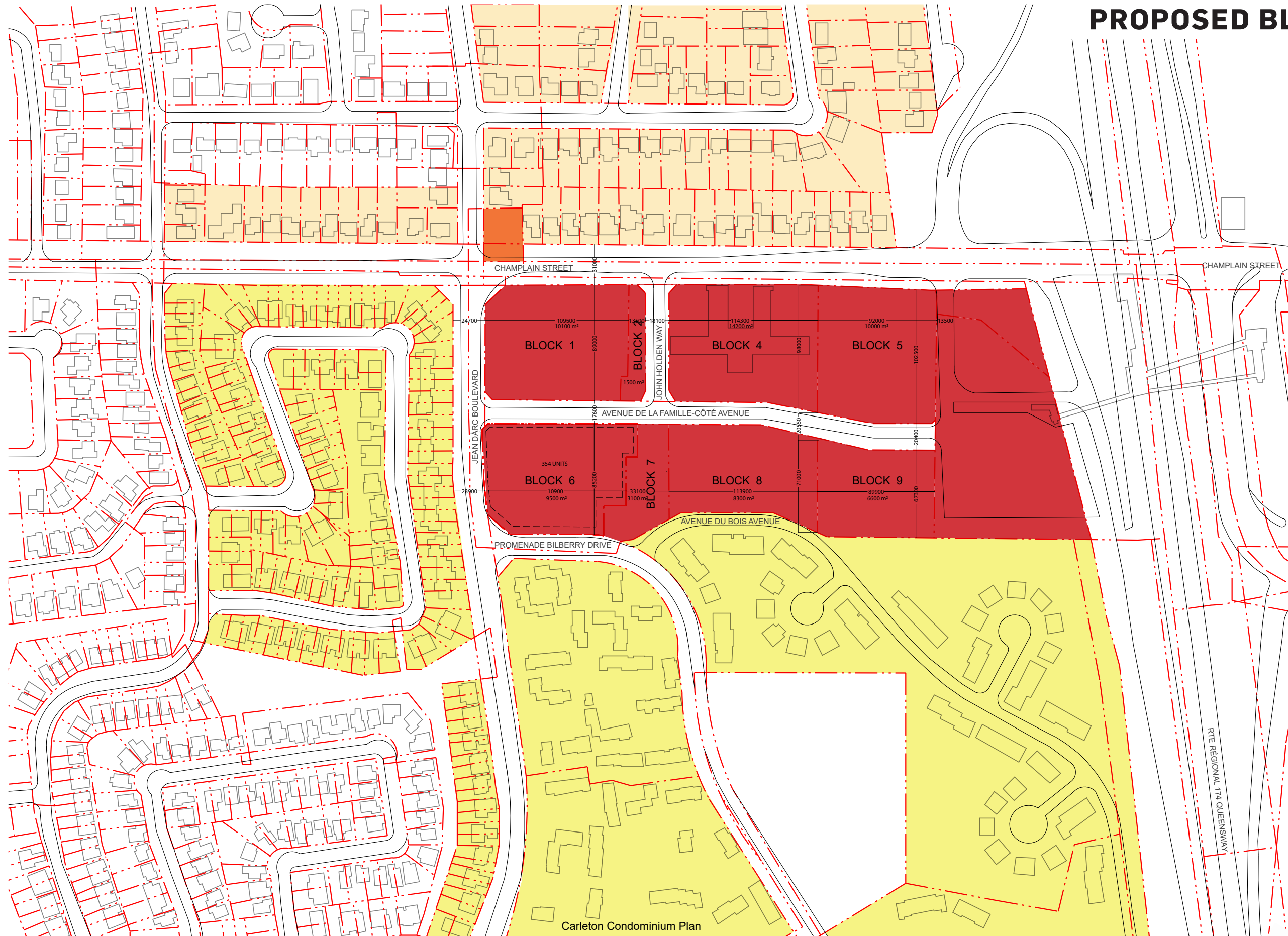

Carleton Condominium Plan

PROPOSED BLOCK PLAN (ZOOMED)

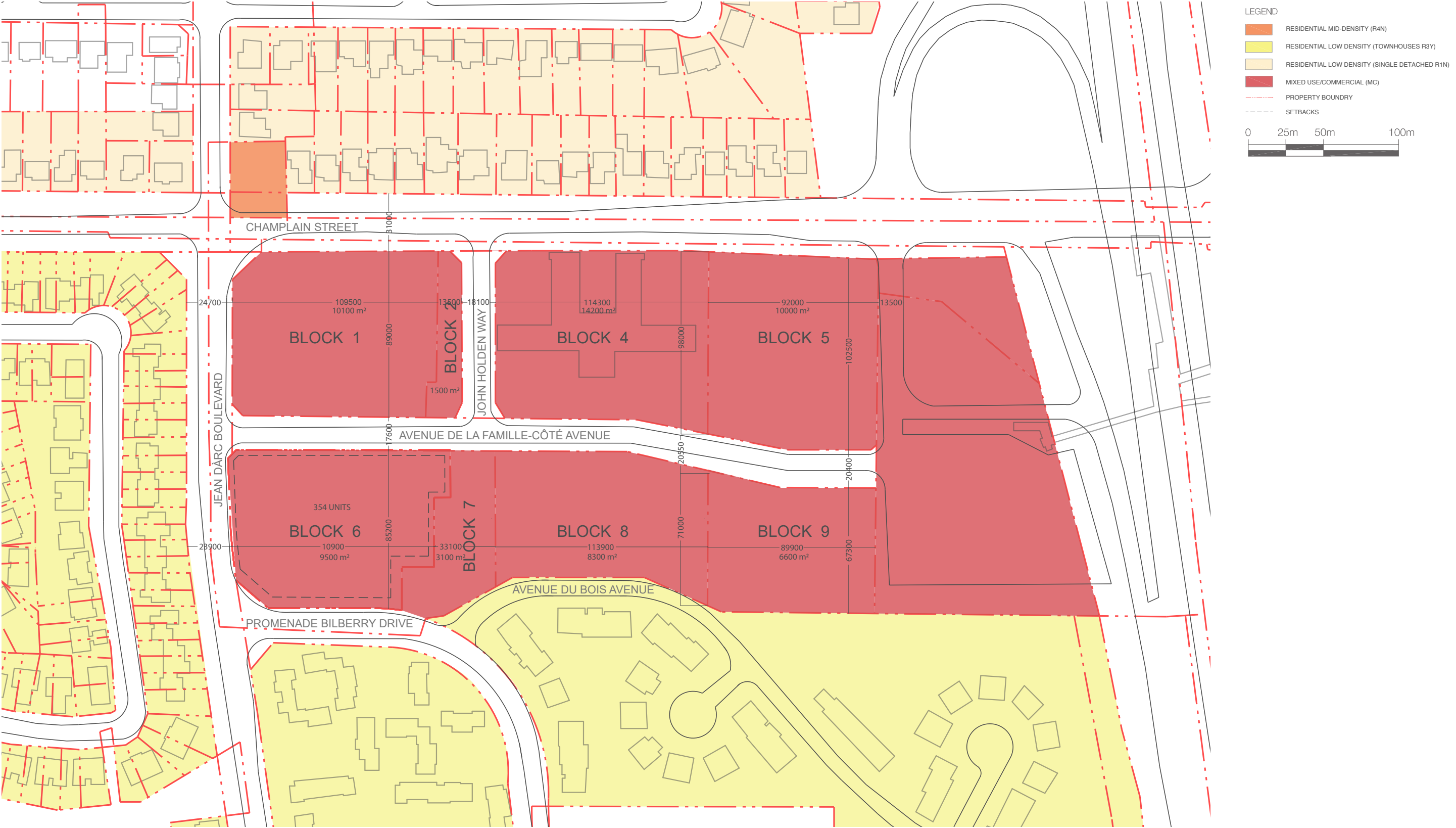

PROPOSED SITE PLAN

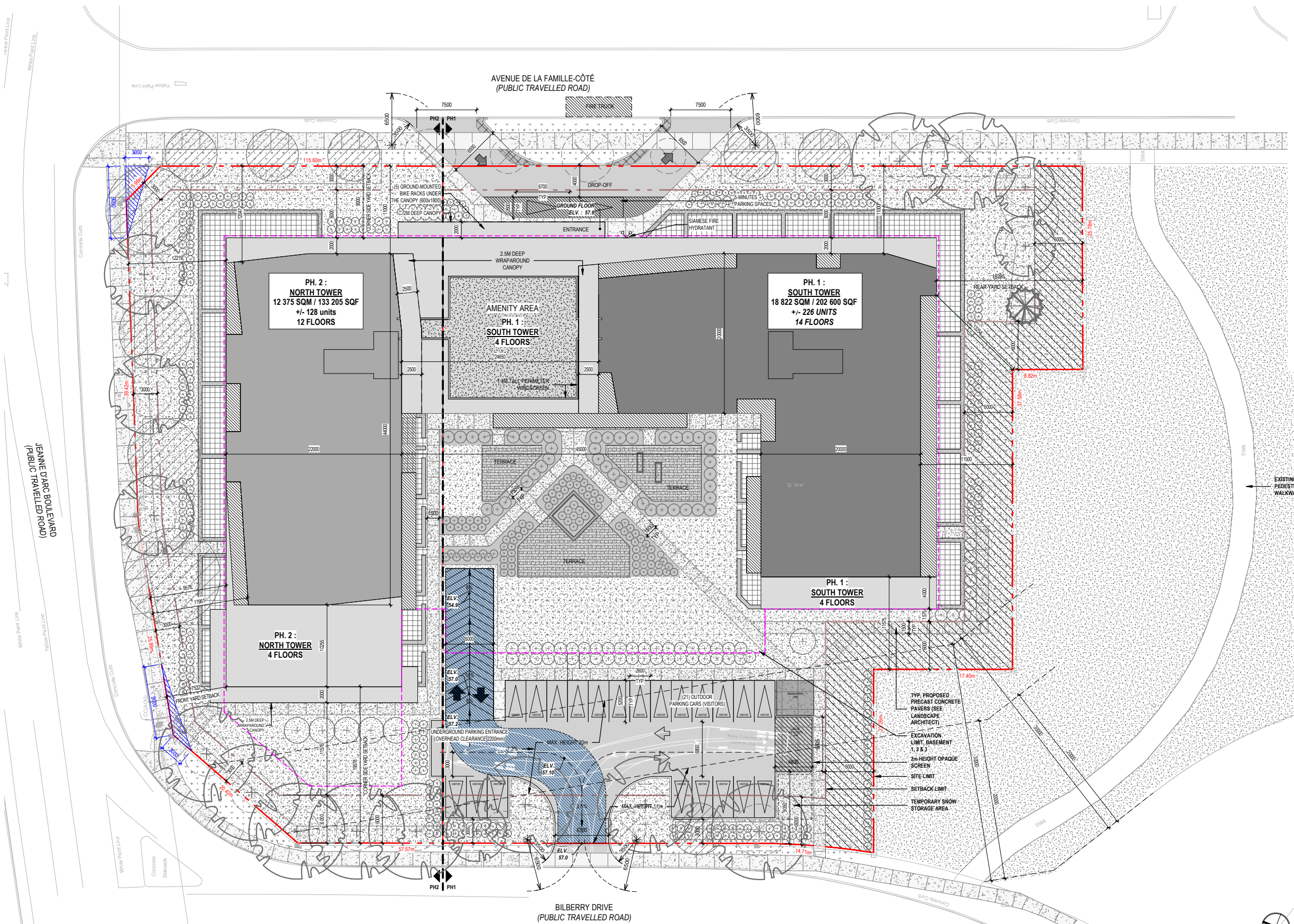

RESPONSES TO PRE-CONSULTATION COMMENTS

500 Famille-Côté Avenue, Ottawa

Response to Comments - Pre-Consultation Meeting Feedback
Site Plan Control Application (PC2024-0522)

No.	Comment	Response
1.0	Urban Design	
	General	
9	Urban Design Brief. Please see attached customized Terms of Reference to guide the preparation. Here are a few highlights: a) The Urban Design Brief should be structured by generally following the headings highlighted under Section 3 – Contents of these Terms of Reference. b) Please document design evolution.	The brief will be structured according to the headings outlined in Section 3. We have also included the design evolution — see attached document.
10	The submission of a UDRP report is a requirement for deeming the site plan control application complete. The Terms of Reference of the UDRP report can be find in this link.	Noted
11	Additional drawings and studies are required as indicated in the attached Urban Design Brief and below. These should also be checked out on the Studies and Plan Identification List (SPIL). These additional drawings and studies must be included in the Urban Design Brief since the Urban Design Brief will also serve as the UDRP submission: 1. Shadow Study 2. Wind Study 3. Grading Plan 4. Landscape Plan 5. Site Plan 6. Elevations 7. Floor Plans	Those documents are part of the resubmission
12	Comments on preliminary design: a) Ample setbacks, increased tower separation and tree planting are appreciated in this context. b) Low rise podium is appropriate in the context. c) Please examine alternate tower orientations and floorplates to ensure that micro-climate issues (wind/shadow) are mitigated on the public realm, adjacent properties and amenity areas. The large floorplate and L-Shape of the 14-storey tower is of particular concern. d) Remove the majority of the surface parking. Any remaining visitor surface parking must be well screened from the public realm. e) You may consider extending the low rise podium along the Jeanne D'arc frontage. f) Consider removing the curb cut on Famille Cote and provide layby parking/drop off instead. This will require consultation with forestry as there are street trees along this frontage. g) Integration with the park is important. Think about the ground floor programming and landscape programming in this area – individual ground terraces or POPs space for example. Please discuss the approach in the design brief. h) Detach the podium from the tower along Jeanne D'Arc to maintain the low rise character along this street.	a) All setbacks and spacing between towers respect urban planning regulations. The planting of new trees is planned (see site plan and landscape plan). b) A four-level podium (12.75 m) is planned. c) The configuration of the towers has been designed to limit wind and shade issues. Canopies and windscreens have been added to the podium. Trees planted on the groundfloor provide comfort for users. The distance between the two towers also allows for comfortable sunlight. d) A large portion of the outdoor parking spaces has been removed. Twenty parking cases on Bilberry drive and a drop-off area on Famille Coté Street remain. These spaces will be visually screened from the public street with soft landscaping." e) The low-rise podium has been extended along the Jeanne d'Arc frontage f) The parking curb along Famille Coté has been removed and the drop-off area has been positioned to preserve the existing trees. g) The landscaping has been designed to link with the park, and individual terraces are planned for the ground floor apartments. (See landscape plan) h) In order to preserve the low-rise character along Jeanne d'Arc Boulevard, the facades of the podium and the tower have been treated differently to visually distinguish them. The outdoor spaces in the podium are alcoves, while those in the tower are balconies, creating a sense of depth.

NEUF

MONTRÉAL
630, boul. René-Lévesque O.
32e étage, Montréal, QC H3B 1S6
T 514 847 1117 F 514 847 2287

OTTAWA
10 Rideau Street
4e étage, Ottawa, ON K1N 9J1
T 613 234 2274 F 613 234 7453

TORONTO
8 Market Street, Suite 600,
Toronto (ON) M5E 1M6
T 416 864 8550 F 514 847 2287

NEUFarchitectes.com

