

10/16/2025 10:58:15 AM CUSTOMER SHEET SIZE  
 PLOT DATE: 2025/09/19 2:05:08 PM

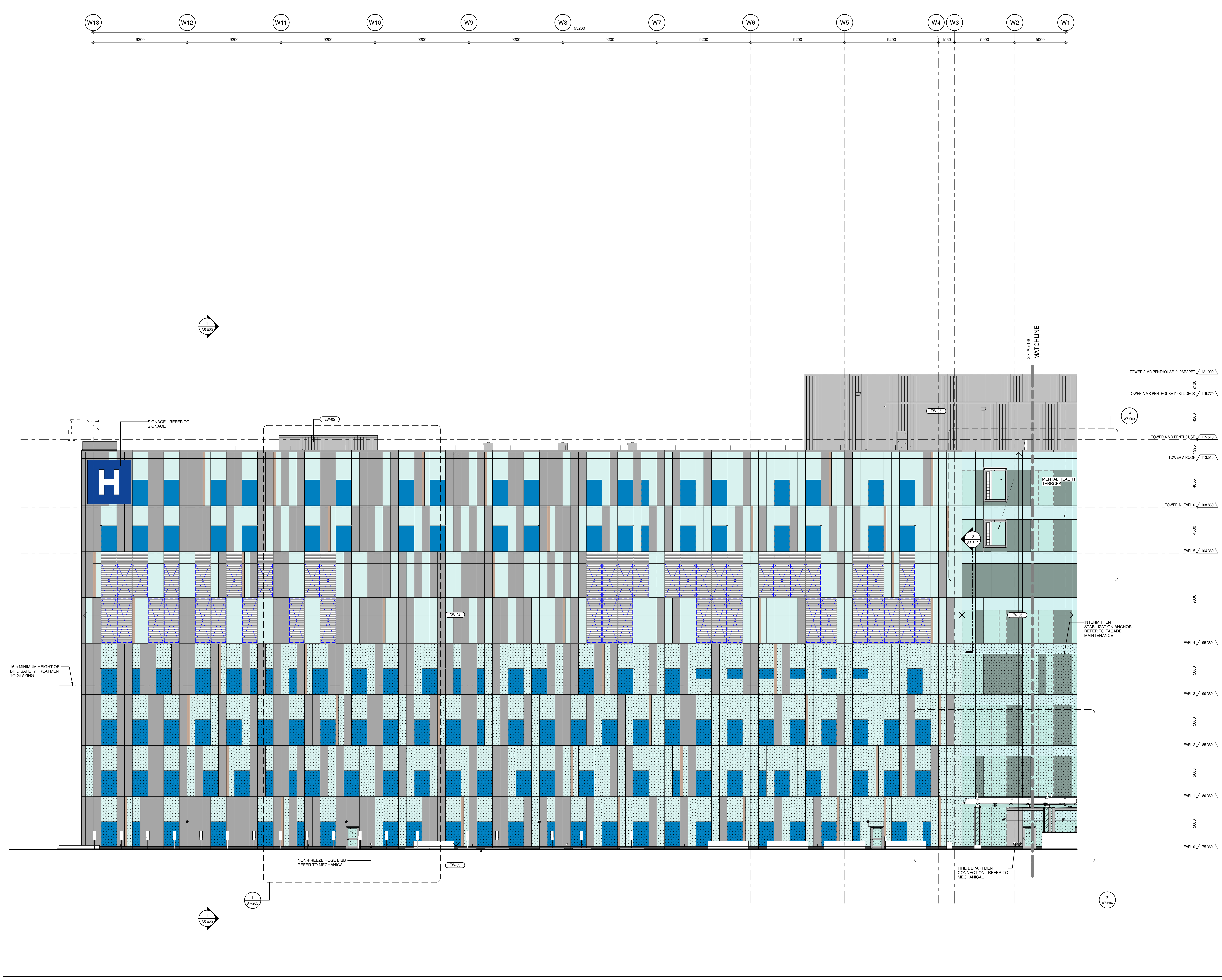

**ELEVATION - WEST TRUE ELEVATION TOWER A**  
 AS-100  
 1-100

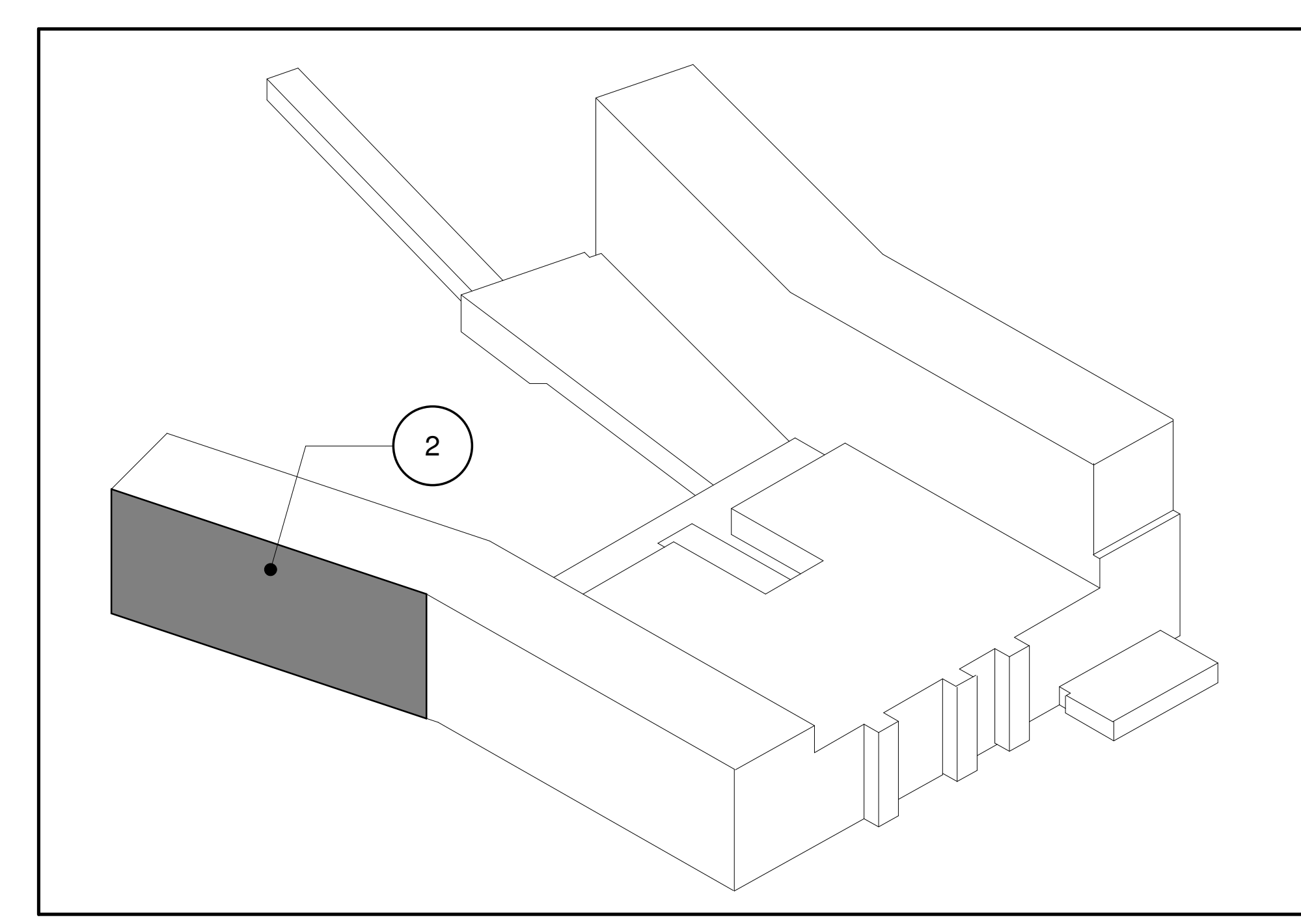

**3D KEY 1**

**GENERAL NOTES**  
 FOR CLADDING GENERAL NOTES, REFER TO AS-110

*SM*  
 SEAN MOORE MCP, PMP  
 MANAGER, DEVELOPMENT REVIEW - WEST  
 PLANNING, INFRASTRUCTURE & ECONOMIC  
 DEVELOPMENT DEPARTMENT, CITY OF OTTAWA

**APPROVED**  
 By Sean Moore at 6:26 pm, Jun 11, 2026

File Number:  
 D07-12-26-0008 (Revision)  
 D07-12-23-0168 (Original)  
 Plan Number: 19424

**PROJECT**  
 THE OTTAWA HOSPITAL  
 NEW CAMPUS  
 DEVELOPMENT -  
 PHASE 4 MAIN HOSPITAL  
 BUILDING  
 900 CARLING AVE. OTTAWA, ONTARIO

**CLIENT**  
 The Ottawa Hospital | L'Hôpital d'Ottawa

**Infrastructure Ontario**

**PCL CONSTRUCTION** | **EllisDon**

**CLIENT PROJECT NO.**  
 1070002

**KEY PLAN**  
 TRUE NORTH | PROJECT NORTH

**REVISIONS**

NO.	DESCRIPTION	DATE
01	ISSUE FOR PERMIT	2025-09-19
02	DESIGN BUILD BASELINE SUBMISSION	2025-09-19
03	95% DD SUBMISSION	2025-09-19

**DISCREPANCIES MUST BE REPORTED IMMEDIATELY TO THE ARCHITECT BEFORE PROCEEDING. ONLY PLOTTED DIMENSIONS ARE TO BE USED. CONTRACTORS MUST CHECK ALL DIMENSIONS ON SITE. THIS DRAWING IS PROTECTED BY COPYRIGHT.**

**NOT FOR CONSTRUCTION**

**ADAMSON ASSOCIATES ARCHITECTS**  
 A Partnership of Corporations

**PROJECT TEAM**  
**DESIGN-BUILDER** PCL/ED A JOINT VENTURE  
**ARCHITECTURAL** PARSON ARCHITECTS LIMITED, JACOBS LAMARIE PRATTE ARCHITECTS, ADAMSON ASSOCIATES ARCHITECTS, B&B ARCHITECTS OTTAWA INC.  
**STRUCTURAL** SIKAS OPEN CANADA INC., BOUTHILLETTE PARIZEAU INC.  
**MECHANICAL** H&I ANGLUS & ASSOCIATES LTD., SIKAS OPEN CANADA INC.  
**ELECTRICAL** MCKEY SWAN INTERNATIONAL INC.  
**CIVIL** WSP | PARSONS INC.  
**LANDSCAPE** VERDEAS DESIGN INC., PWP LANDSCAPE ARCHITECTURE

**BUILDING CODE** UMO BUILDING CODE CONSULTANTS LTD.

**AUTHOR PROJECT NO.**  
 2233-00

**STAMP**

**DRAWING TITLE**  
 PARTIAL TRUE ELEVATIONS WEST

DRAWN	CHECKED
AAA-PT	JM

SCALE AT 4" x 6" | DATE 19 SEP 2025  
 AS NOTED | GRAPHIC SCALE

**A5-141** | **03**