

DATE: 2024-08-15 10:00 AM

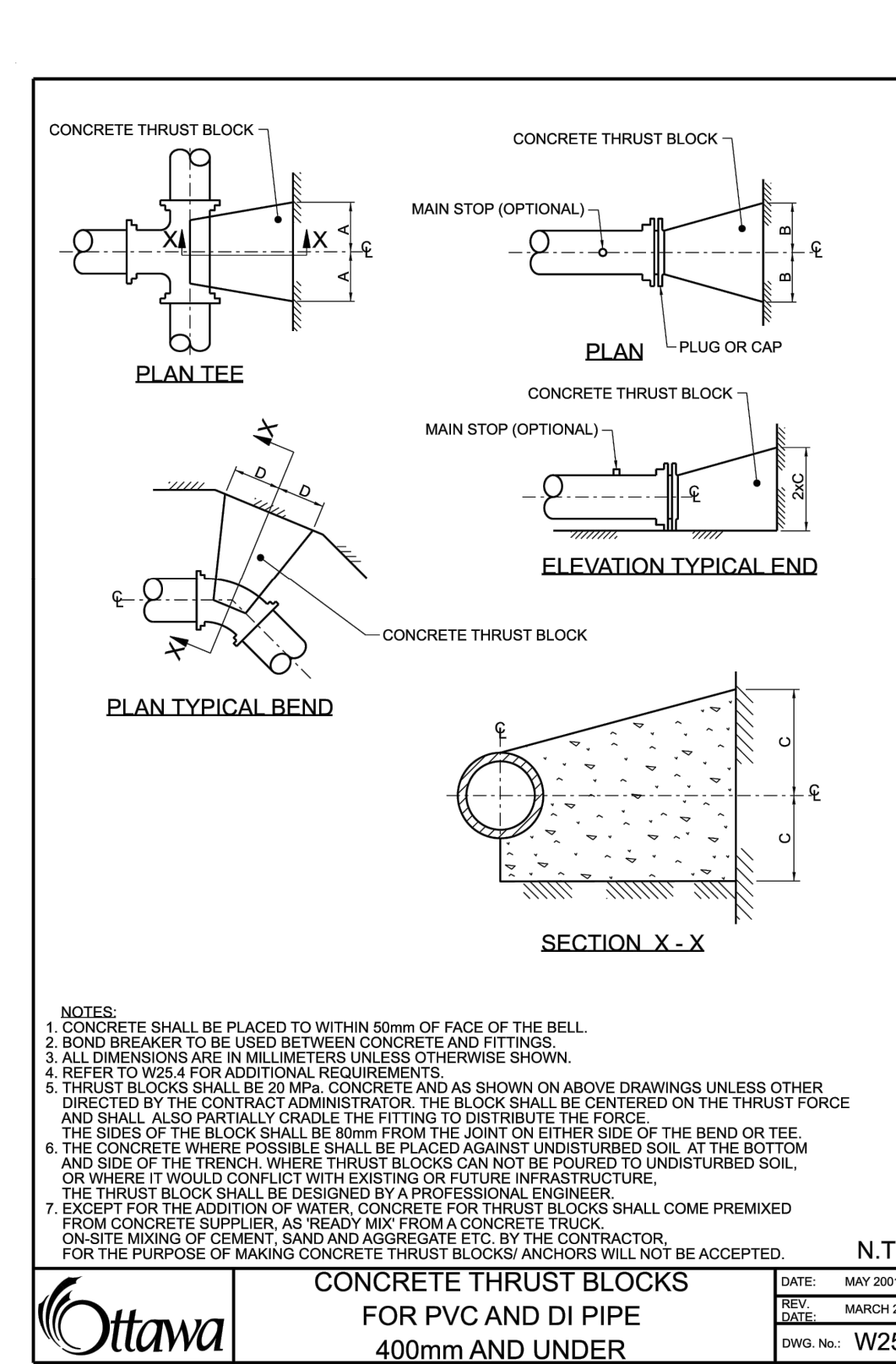

THRUST BLOCK DIMENSION TABLES FOR PVC AND DI PIPE 400mm AND UNDER. Includes tables for soil descriptions and pipe diameters.

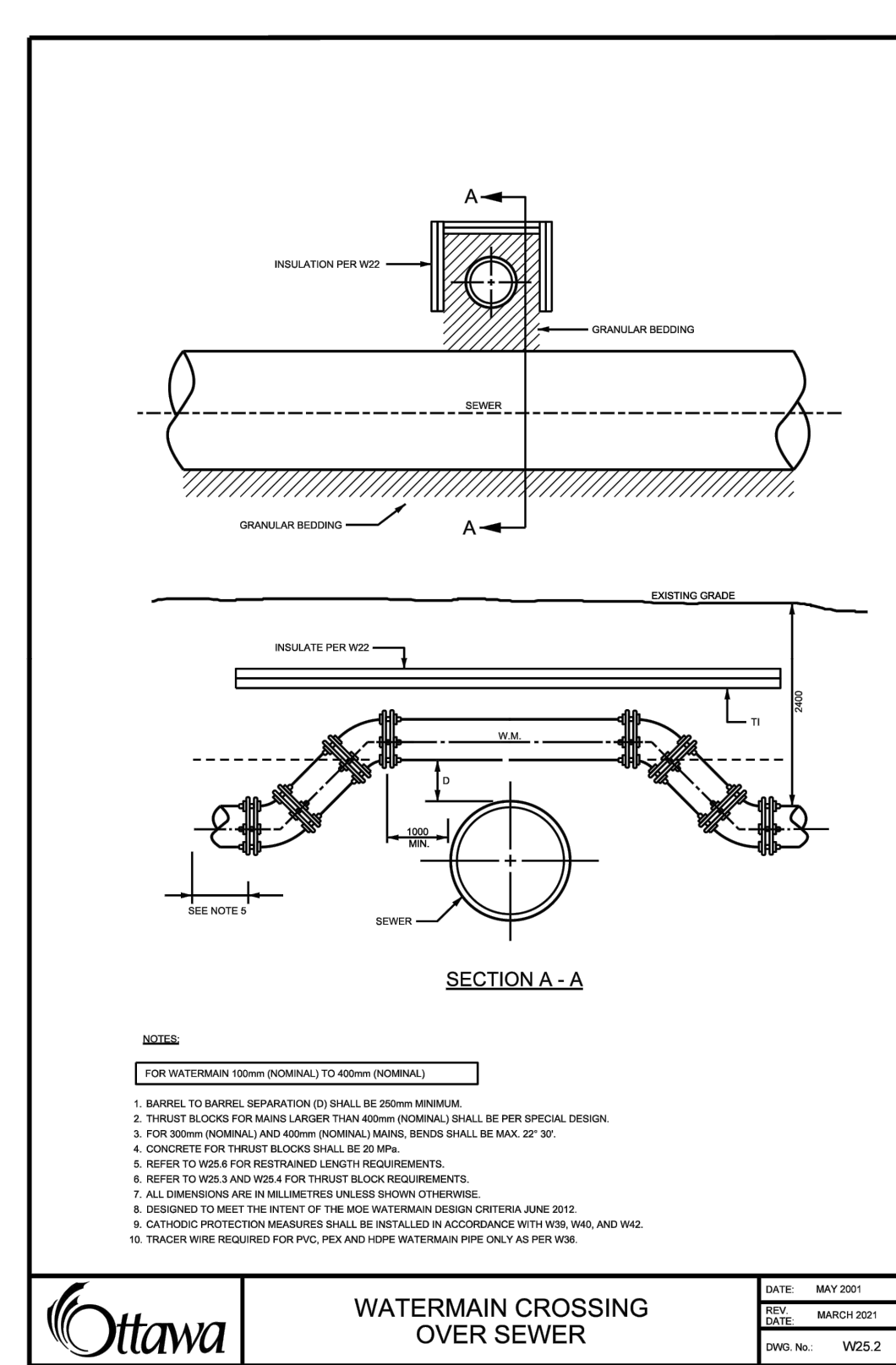
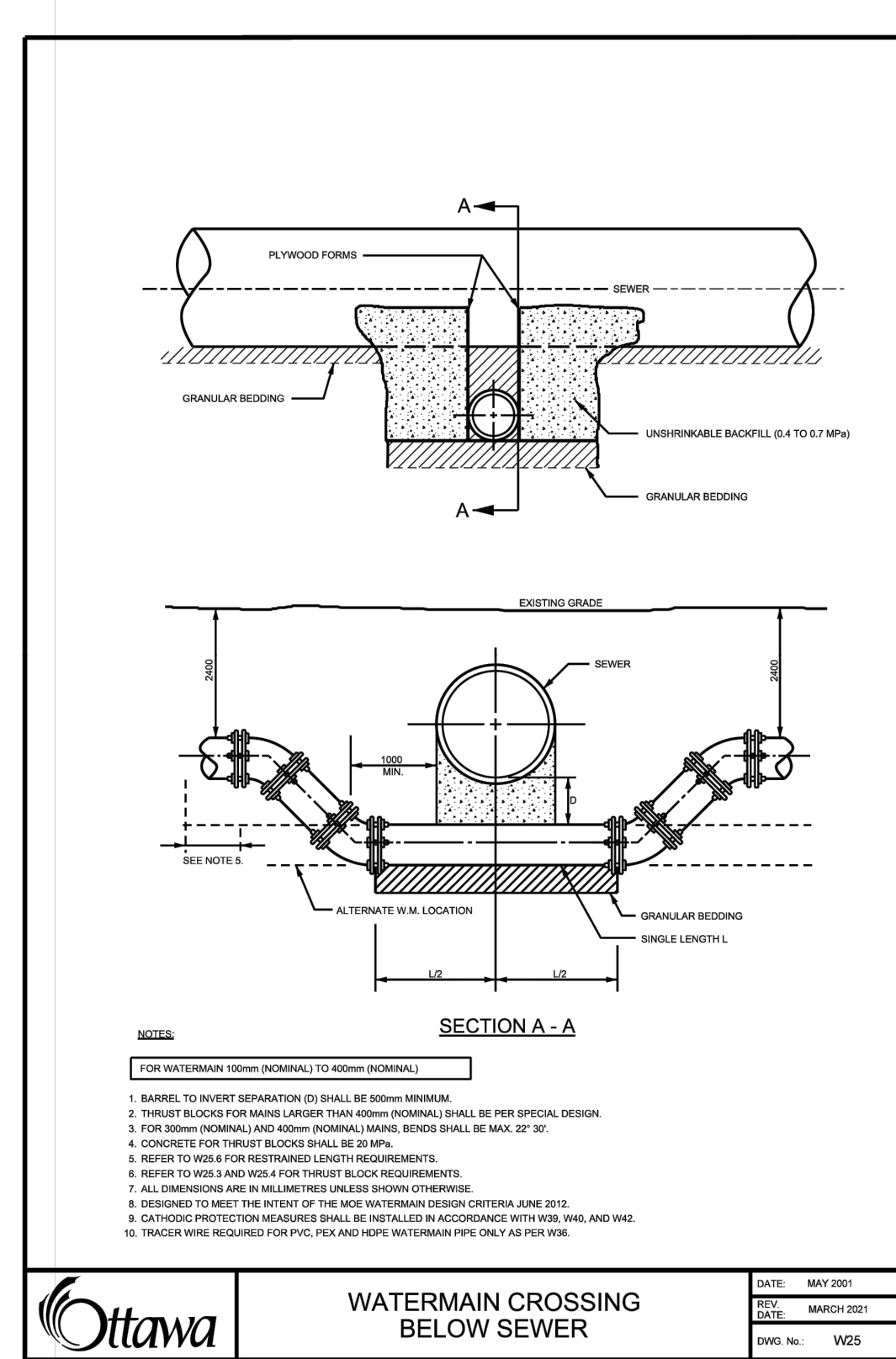
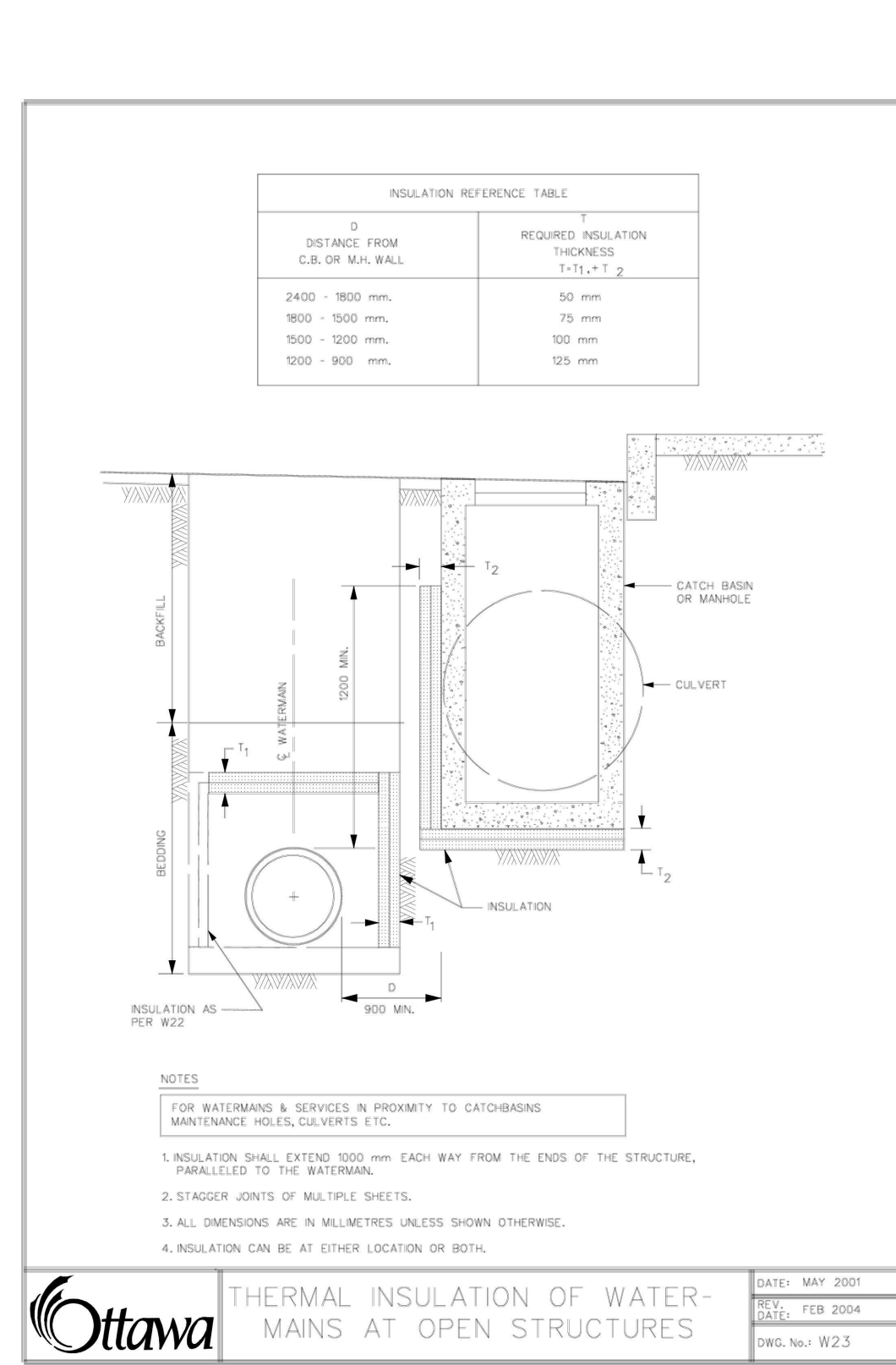
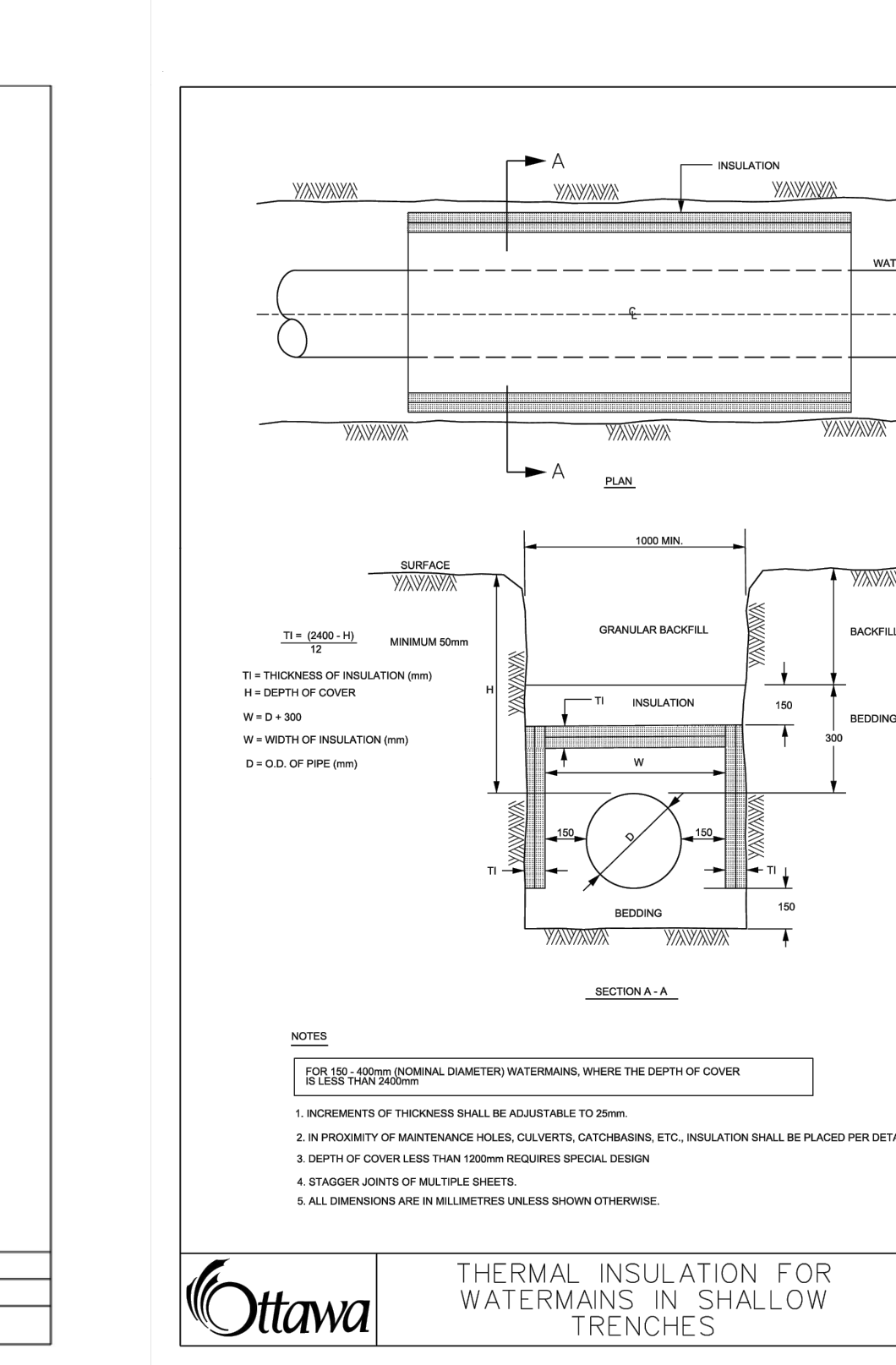
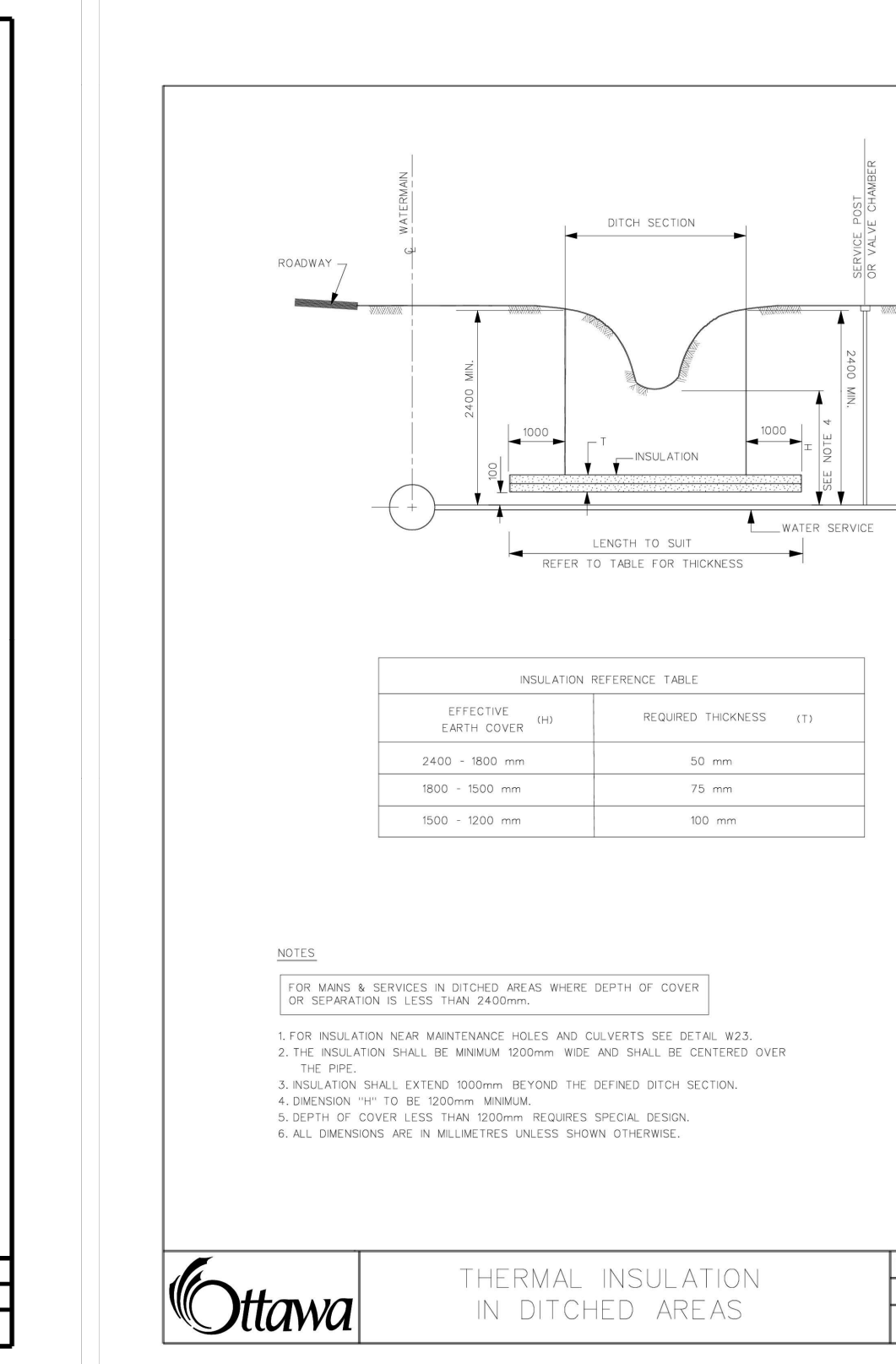
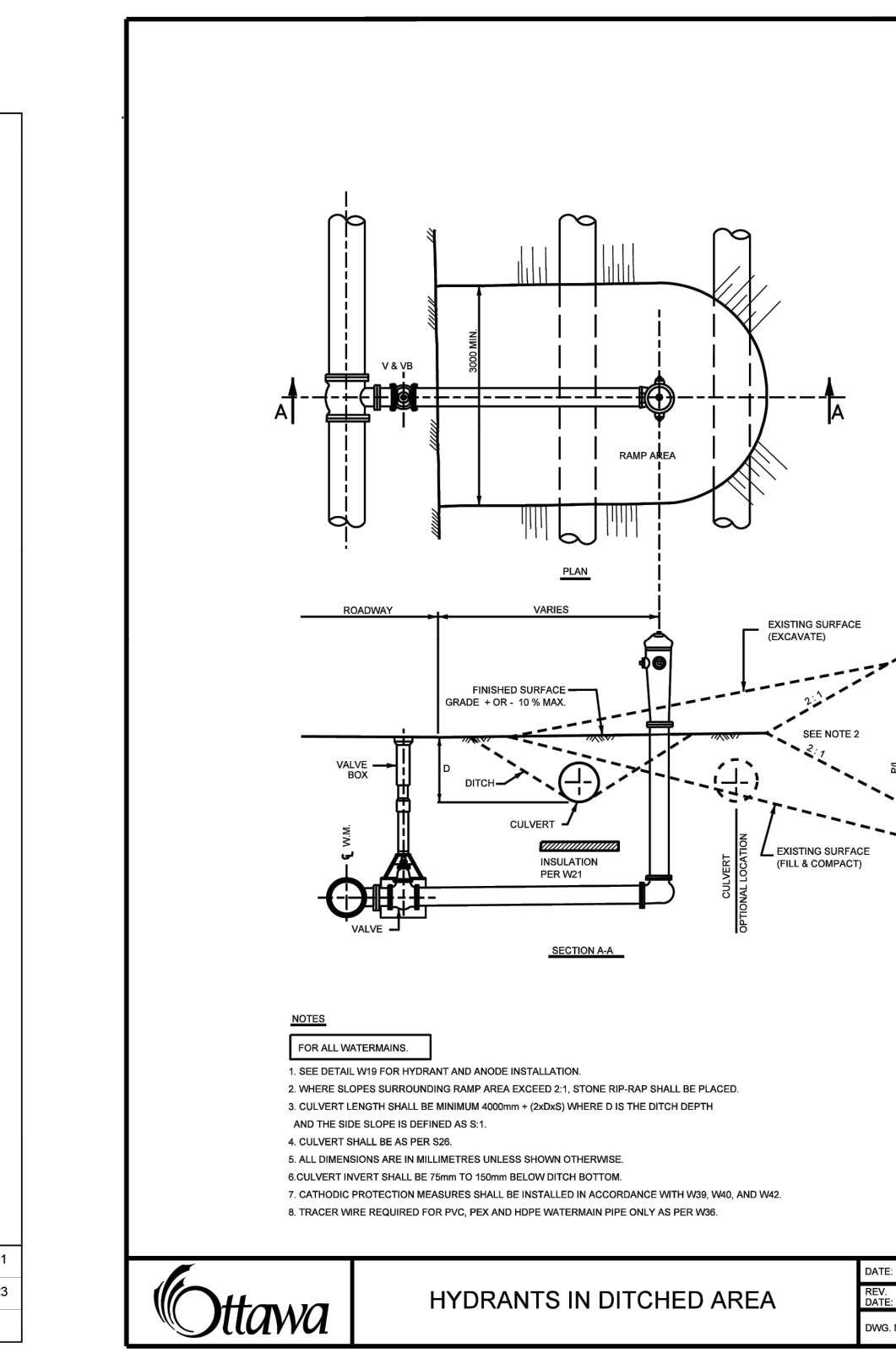
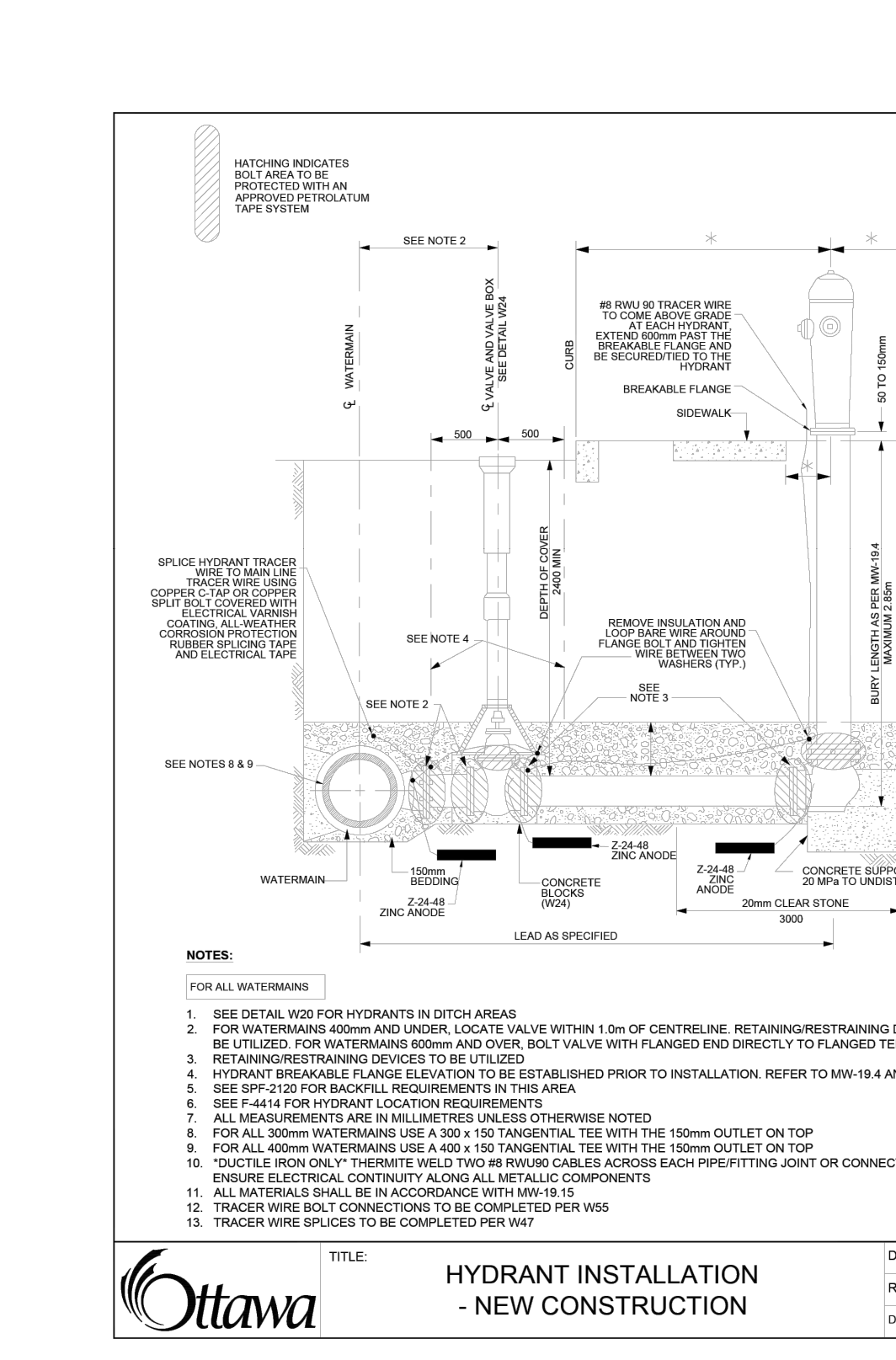
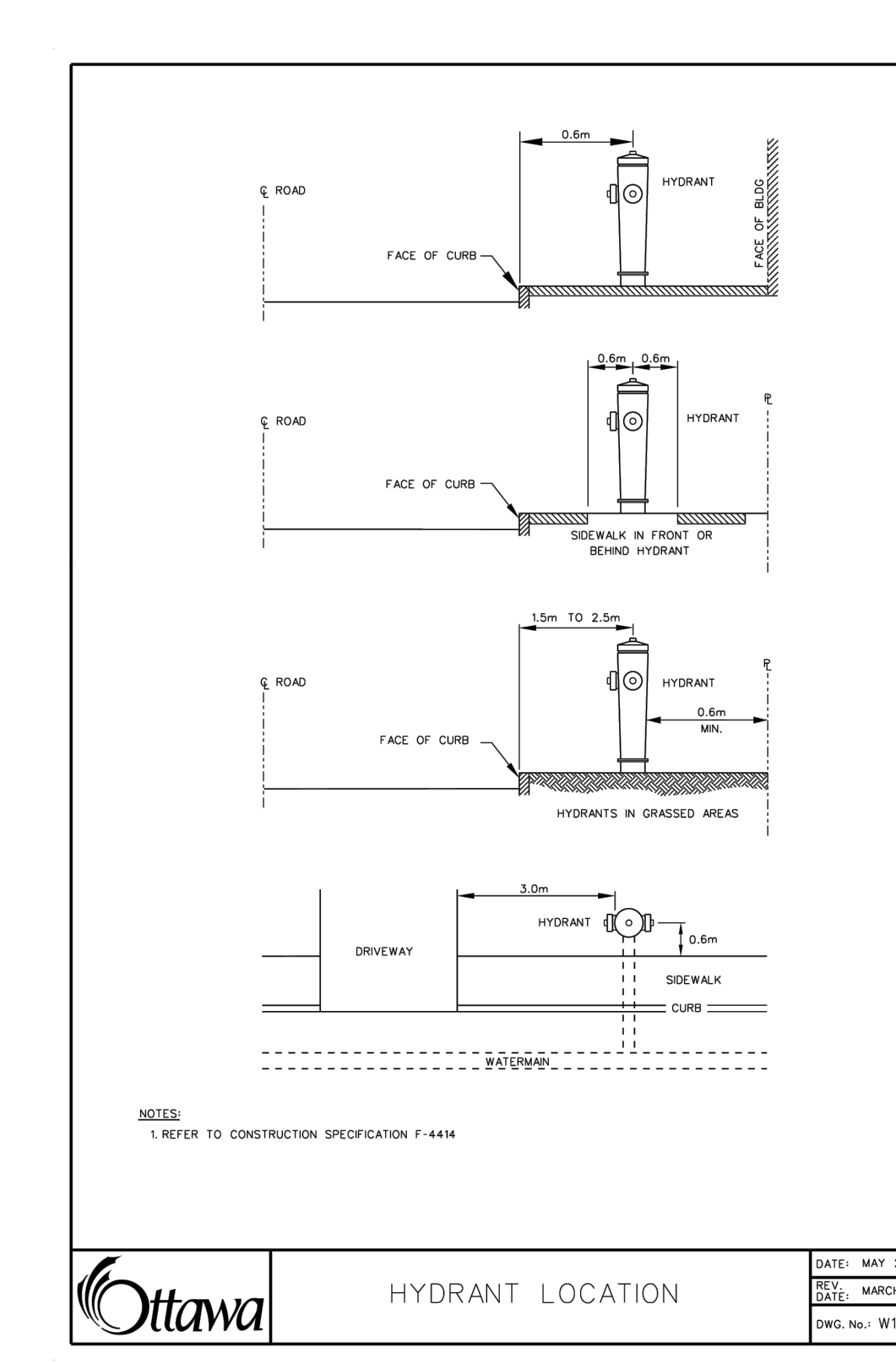
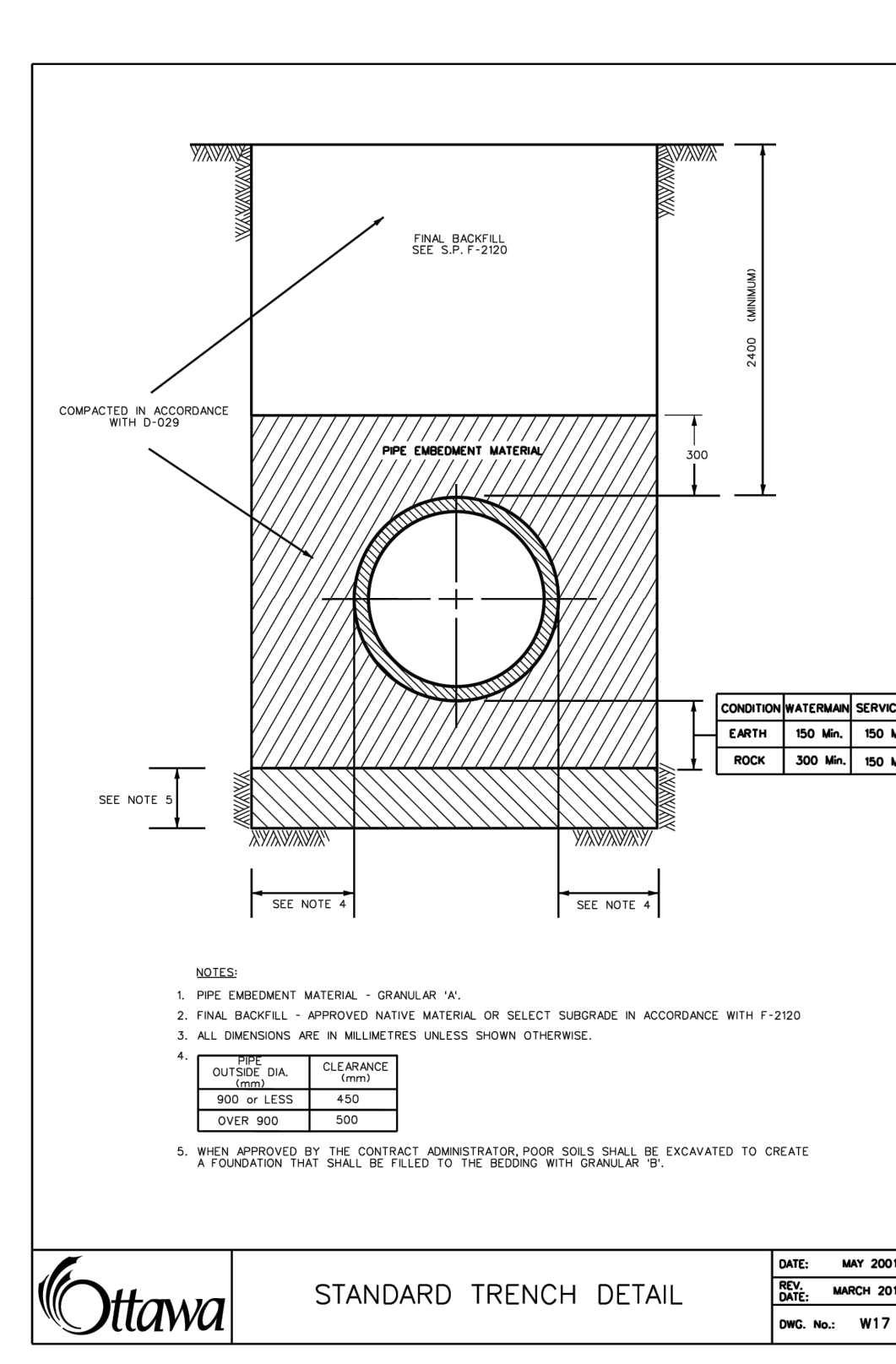
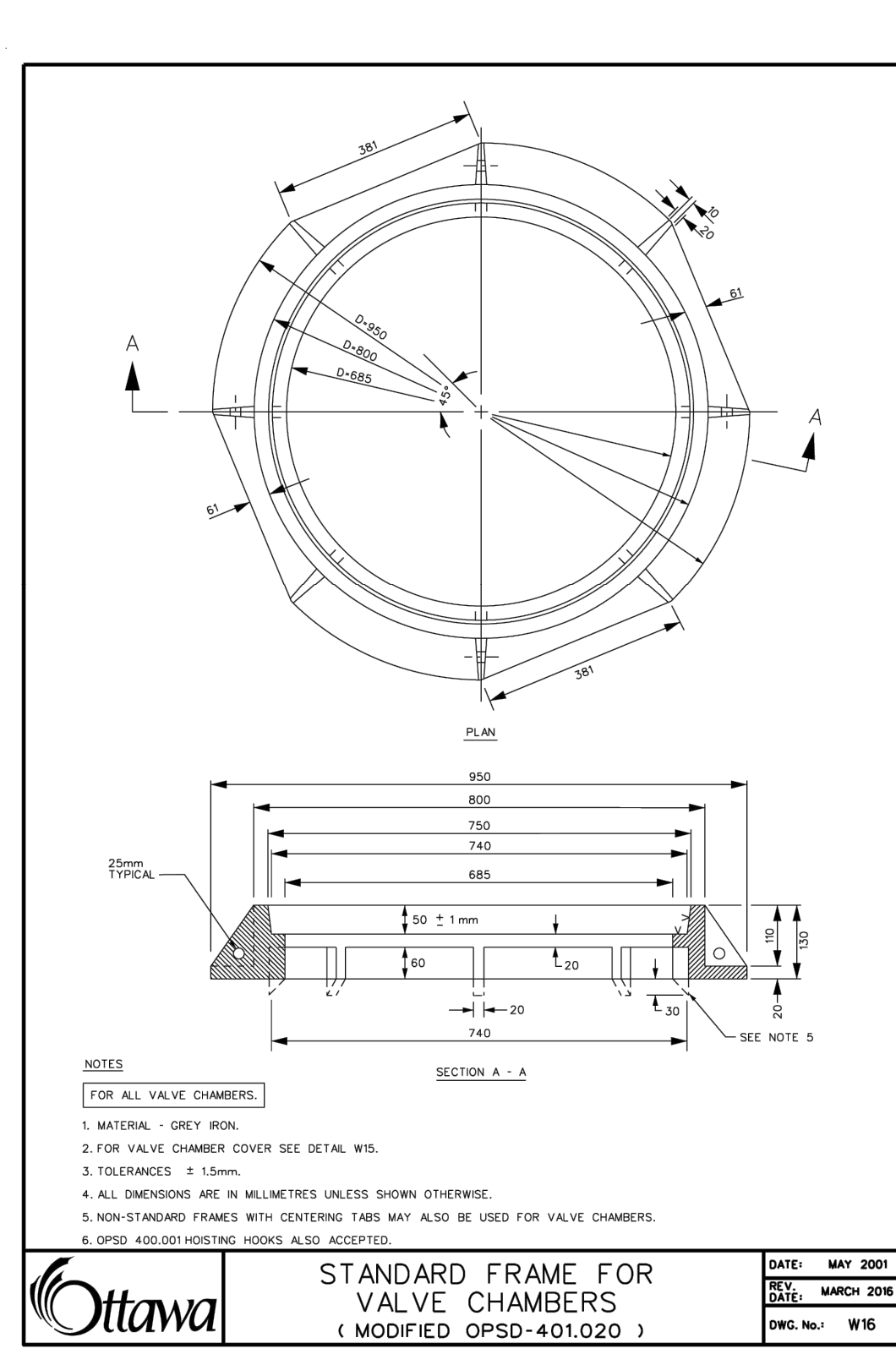
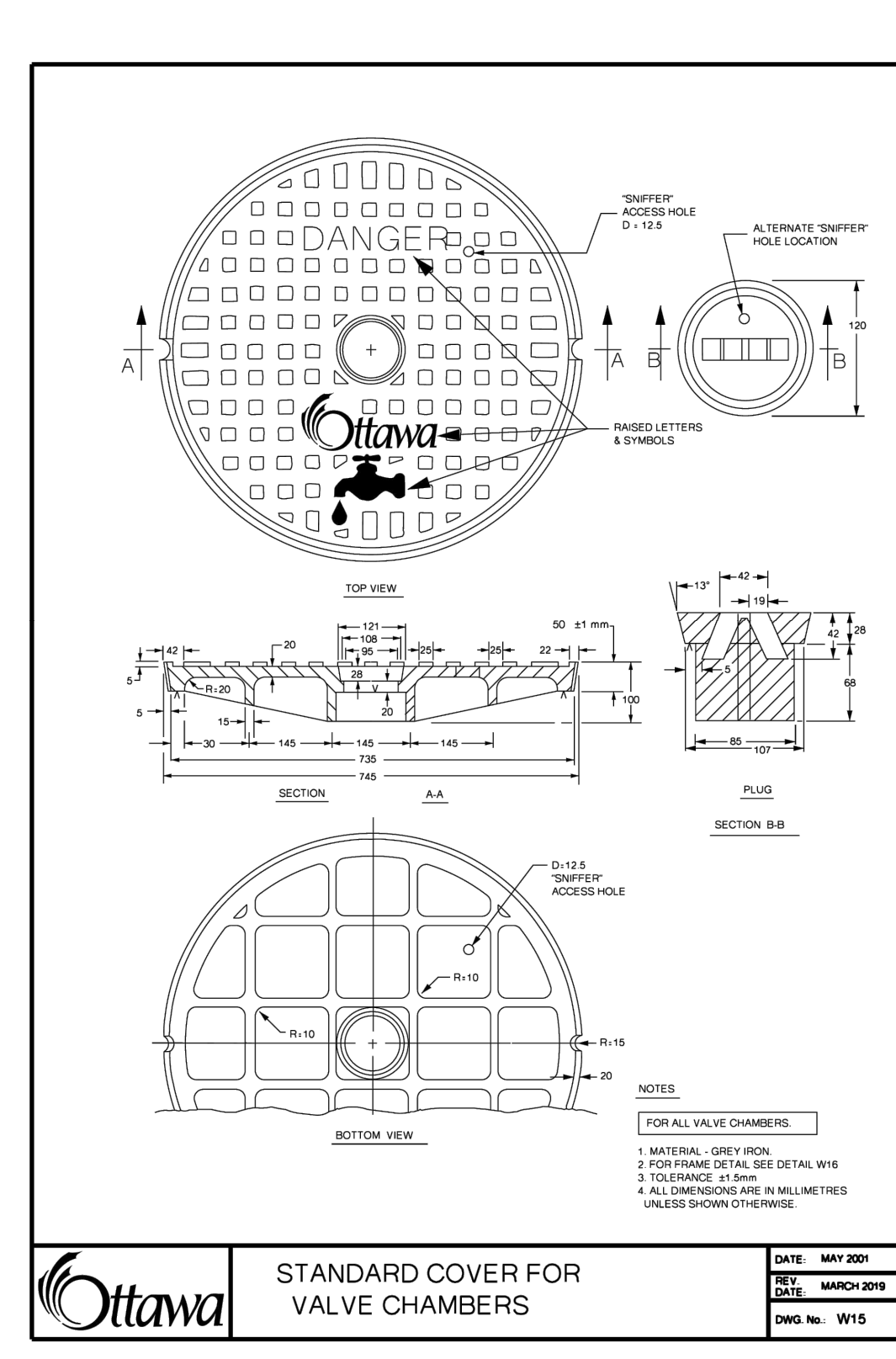
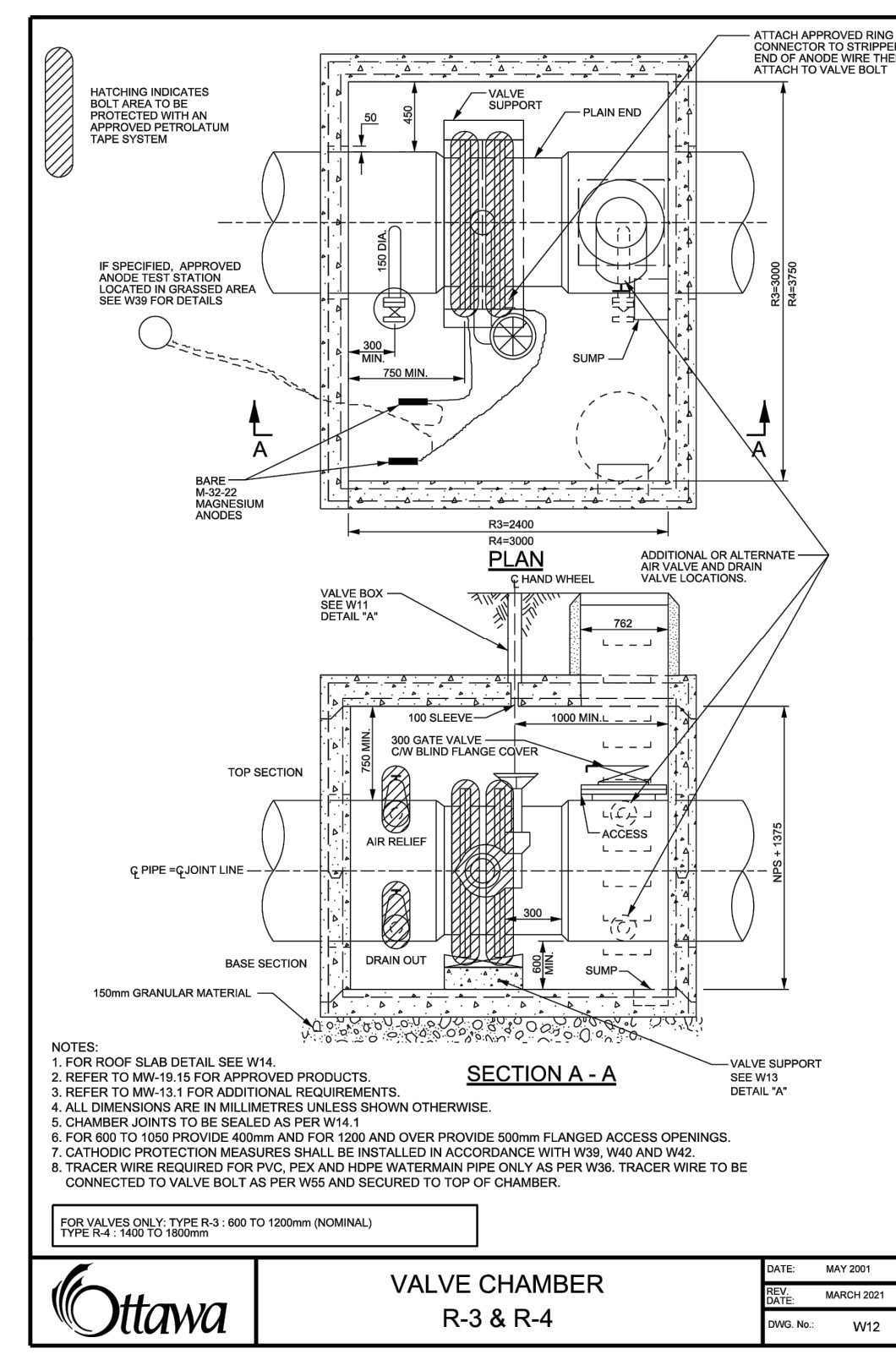
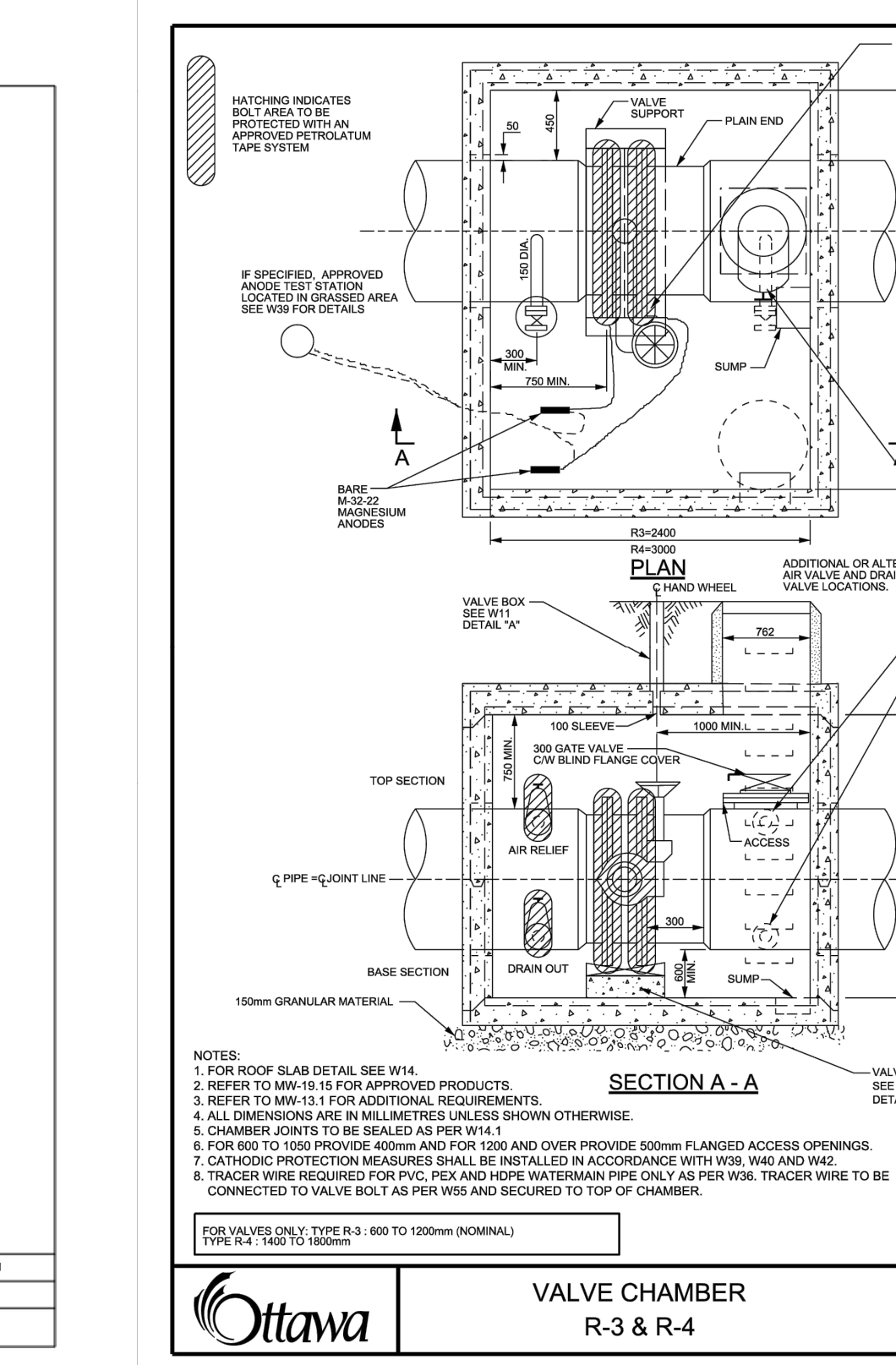
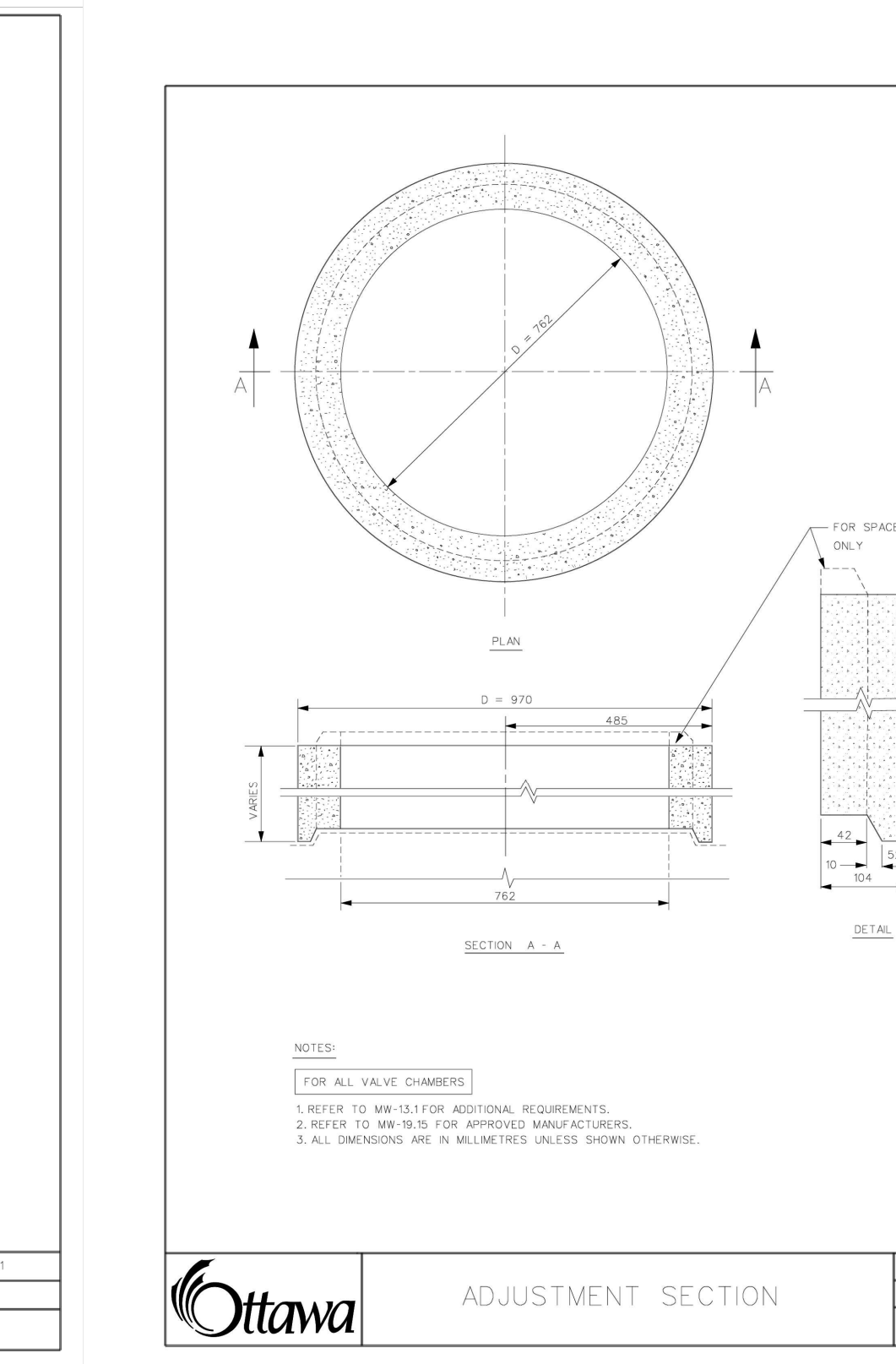
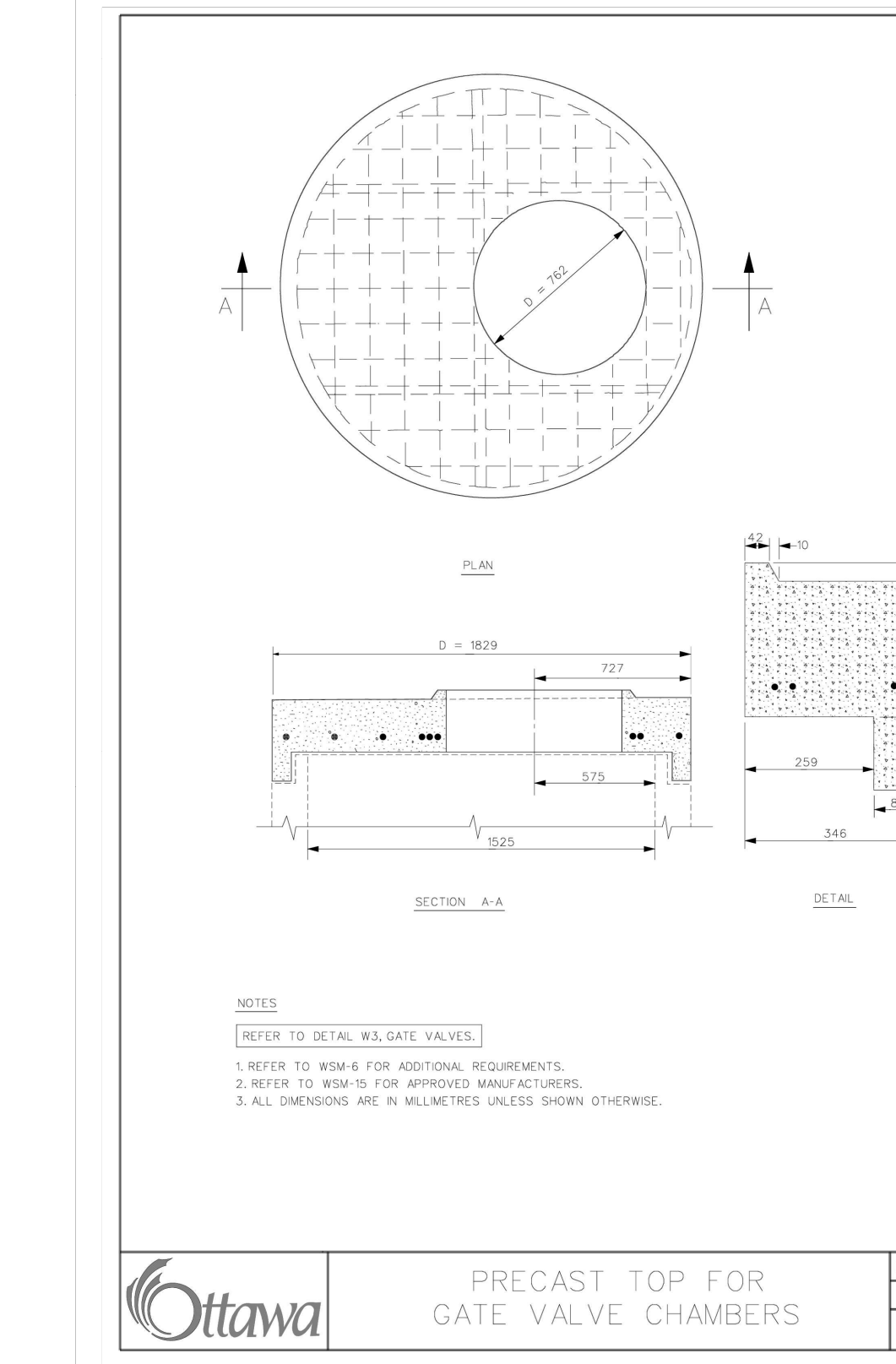
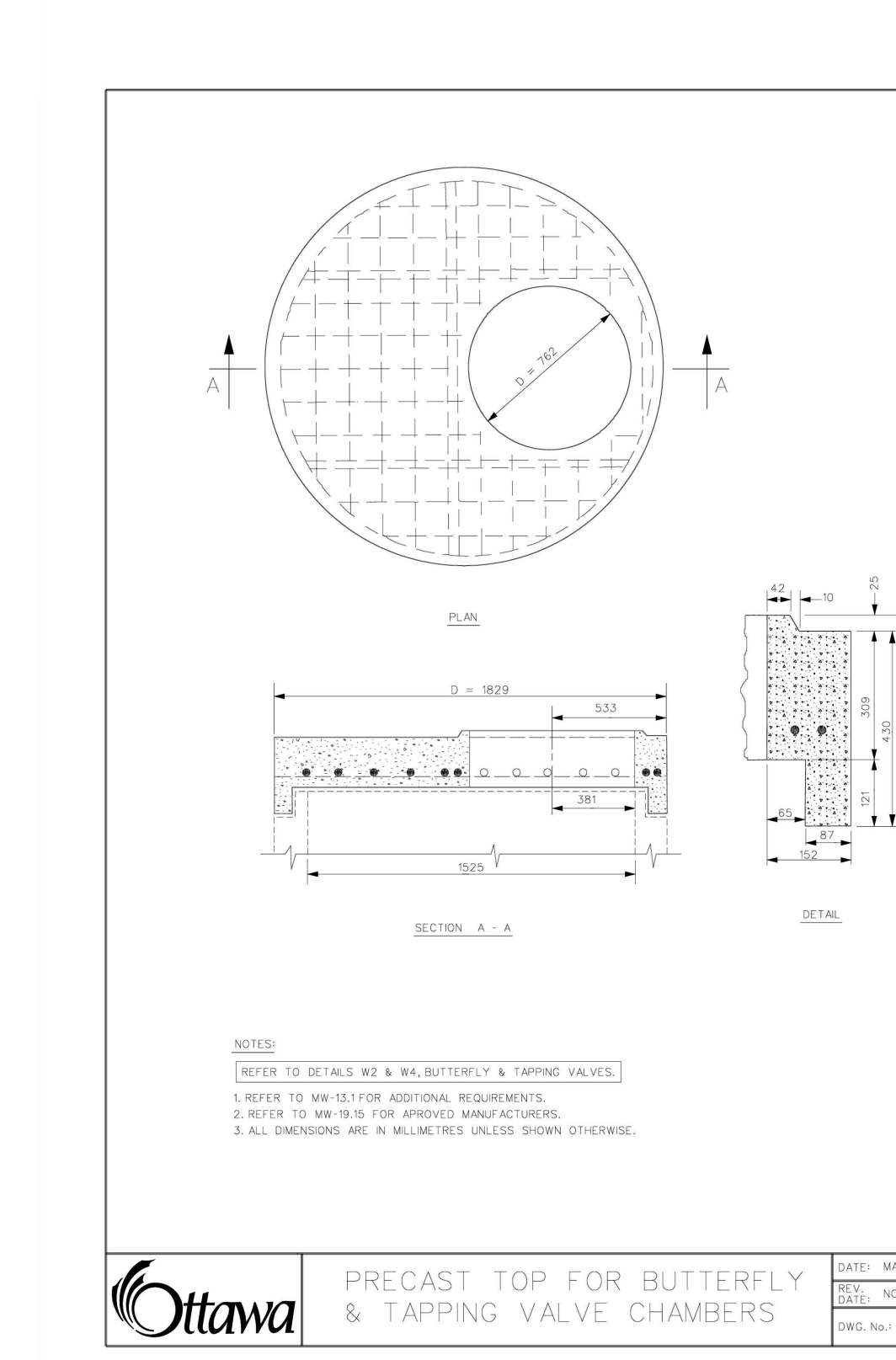
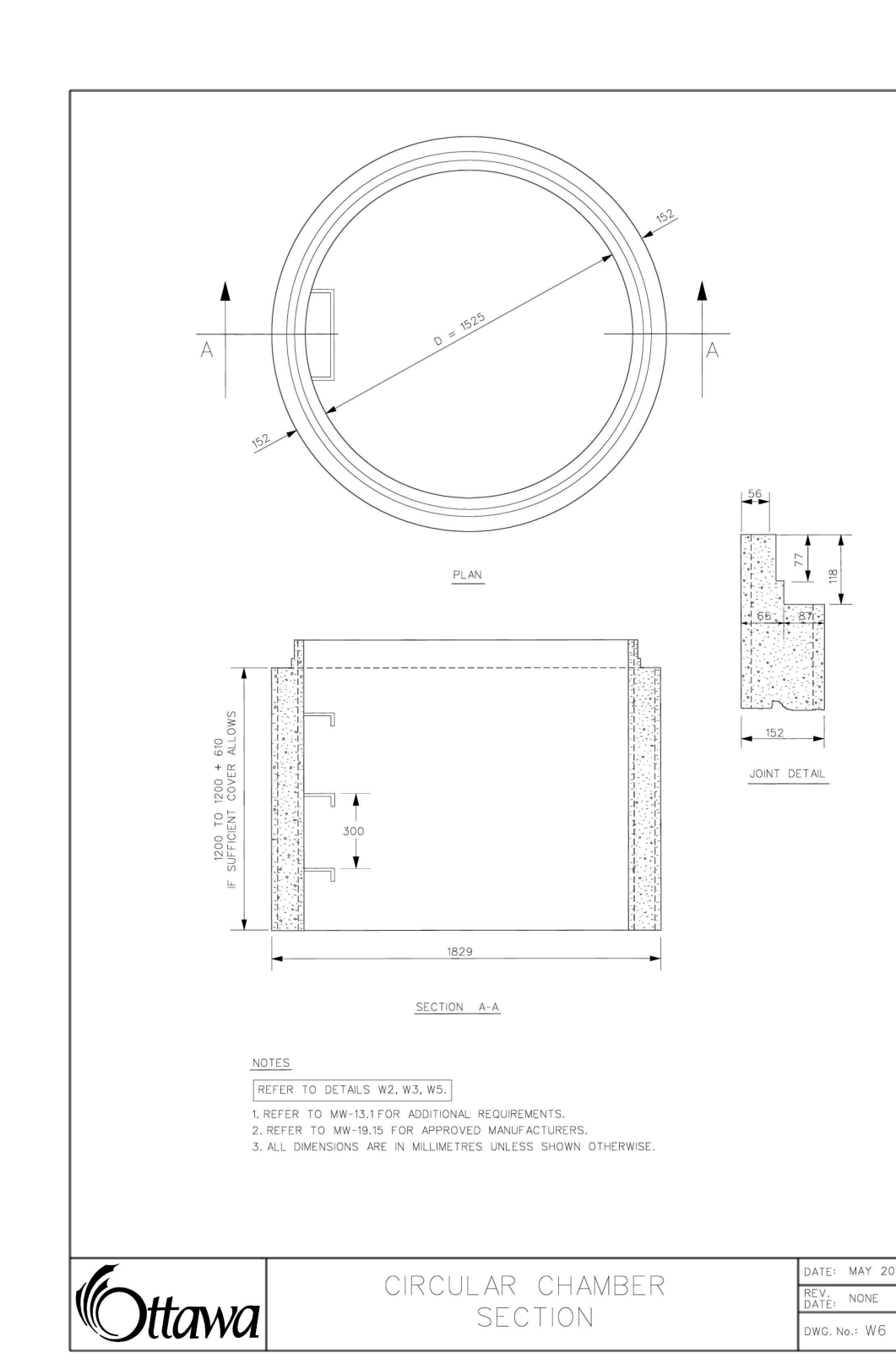
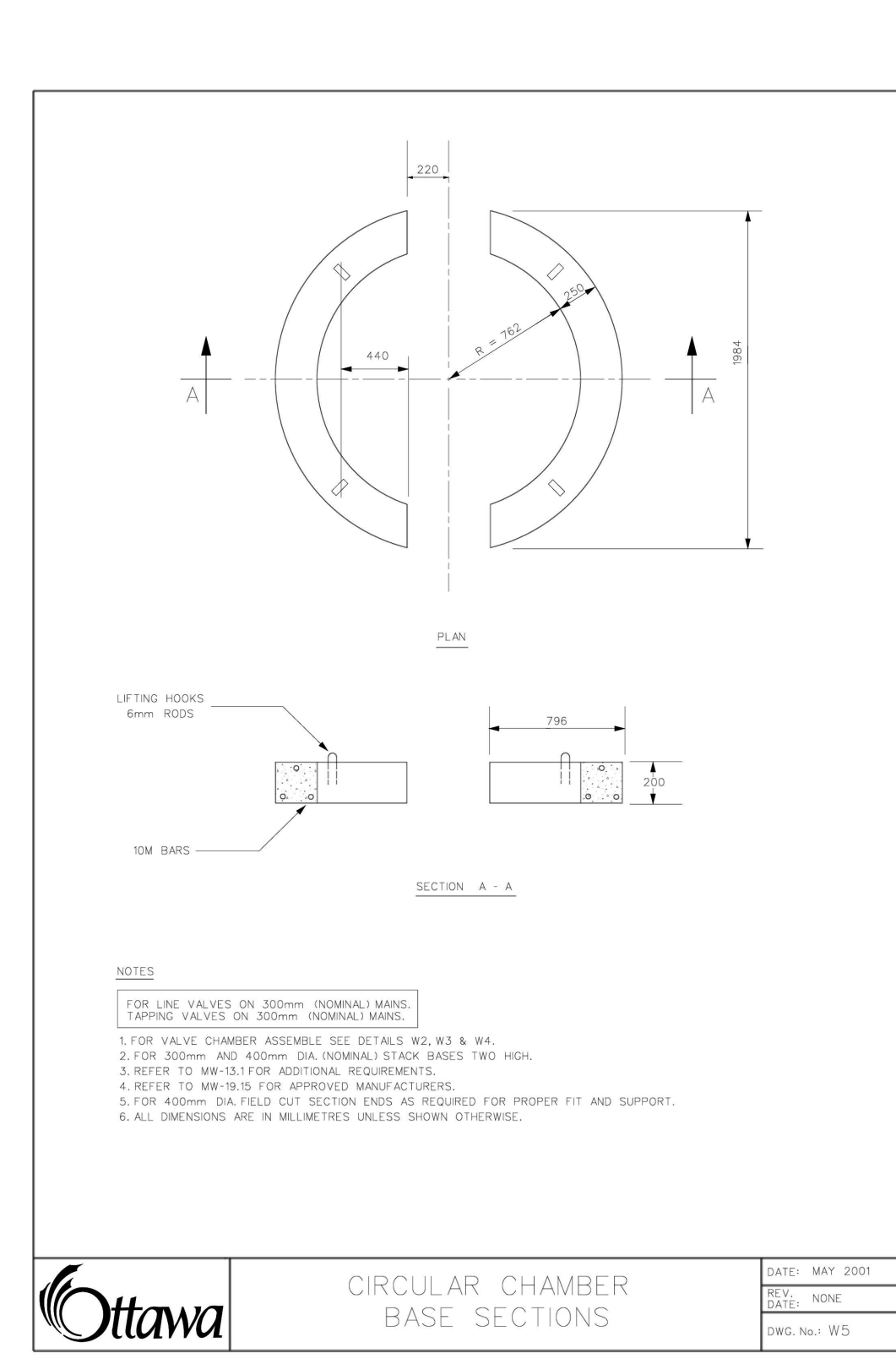
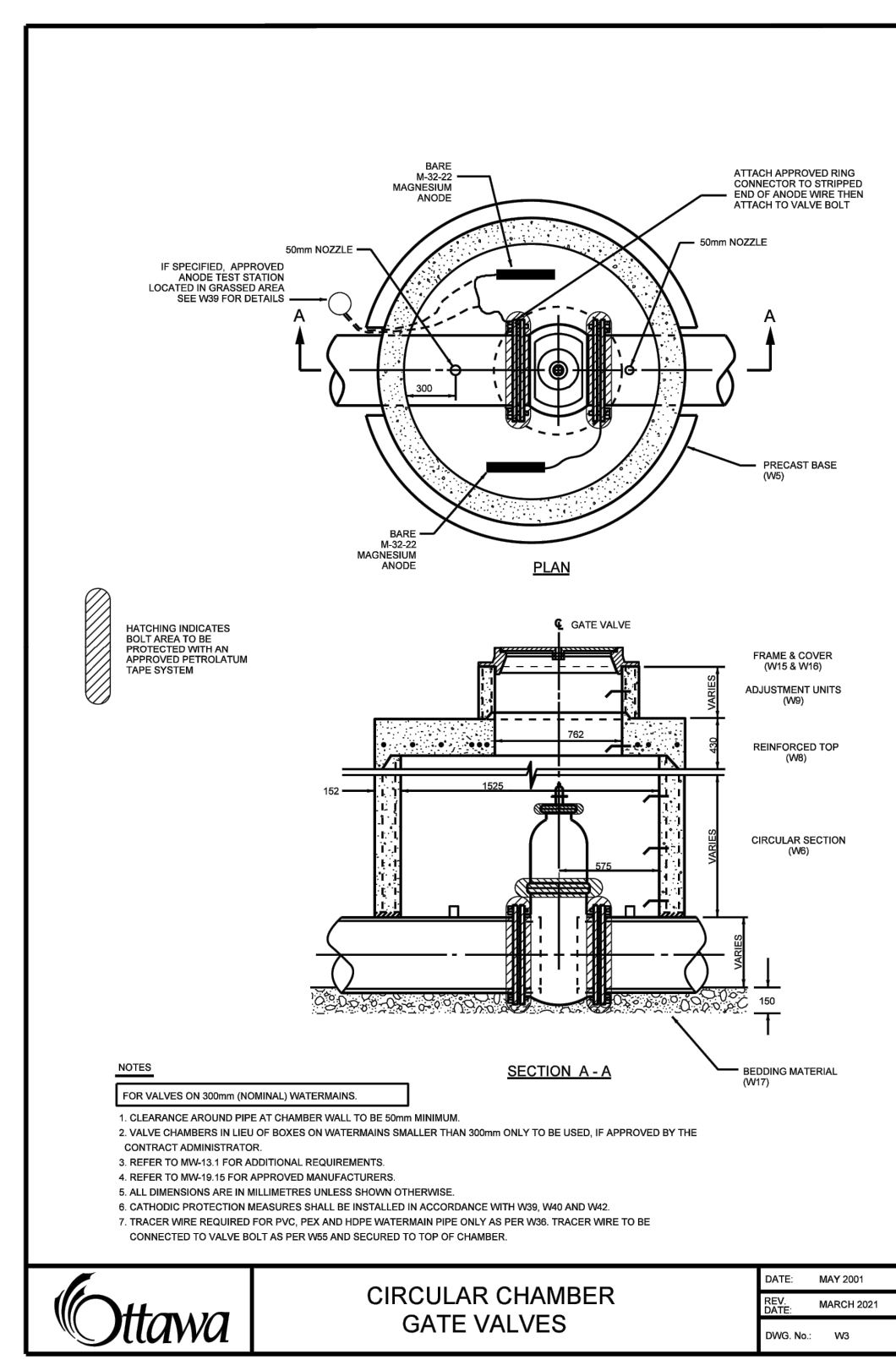
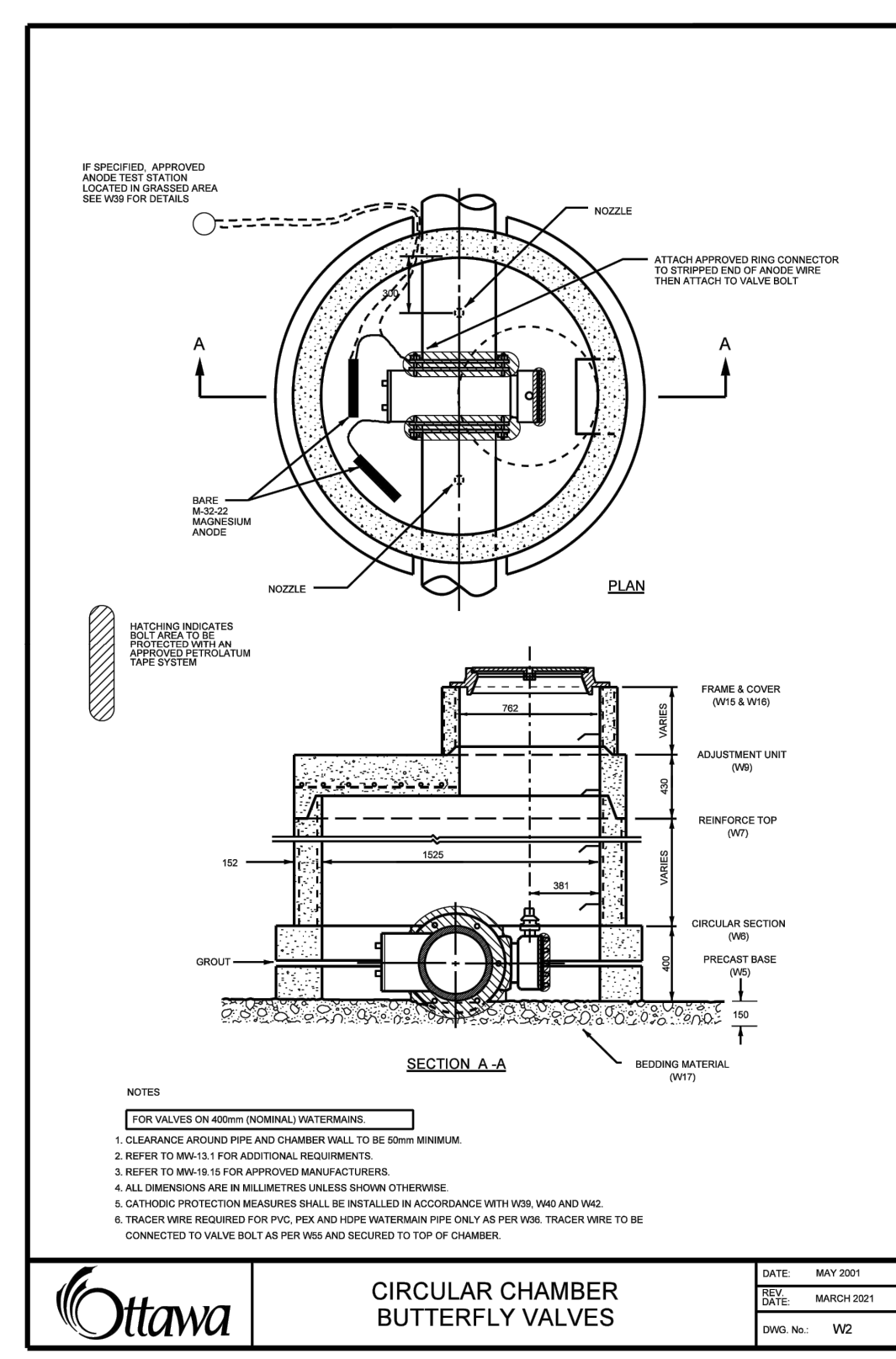
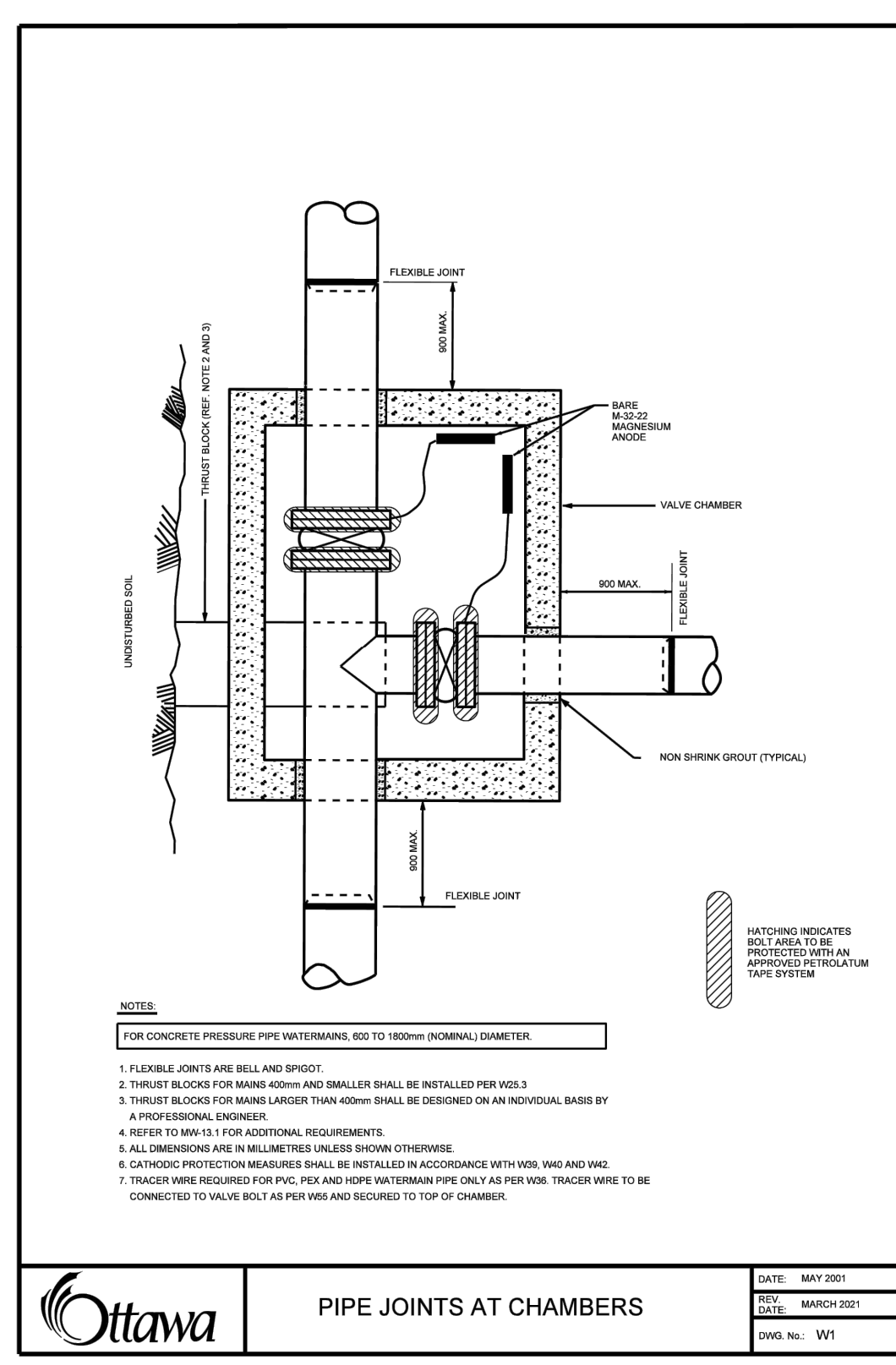
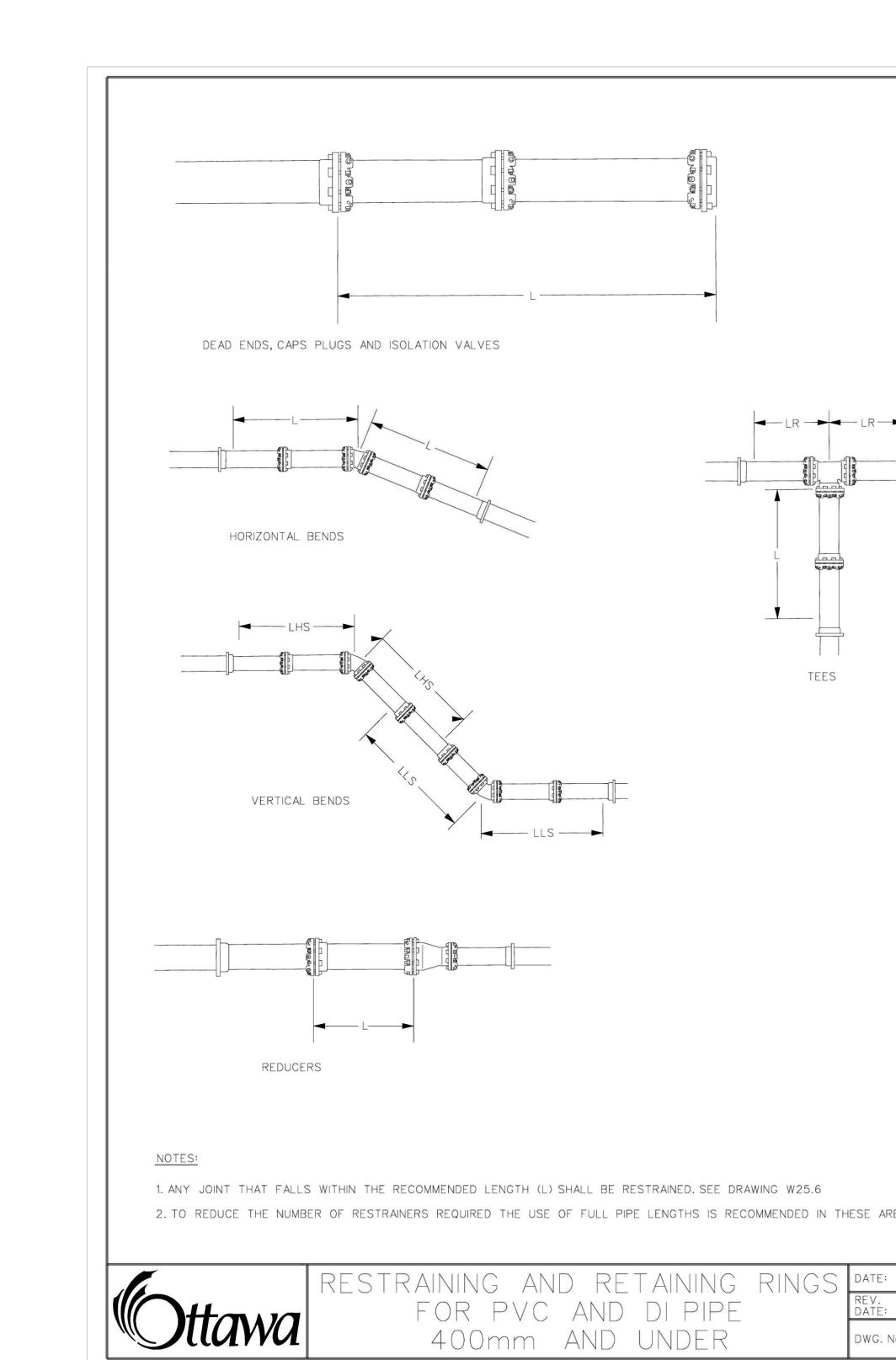

TABLES OF RESTRAINED LENGTHS FOR PVC AND DI PIPE 400mm AND UNDER. Includes tables for restrained lengths and pipe diameters.

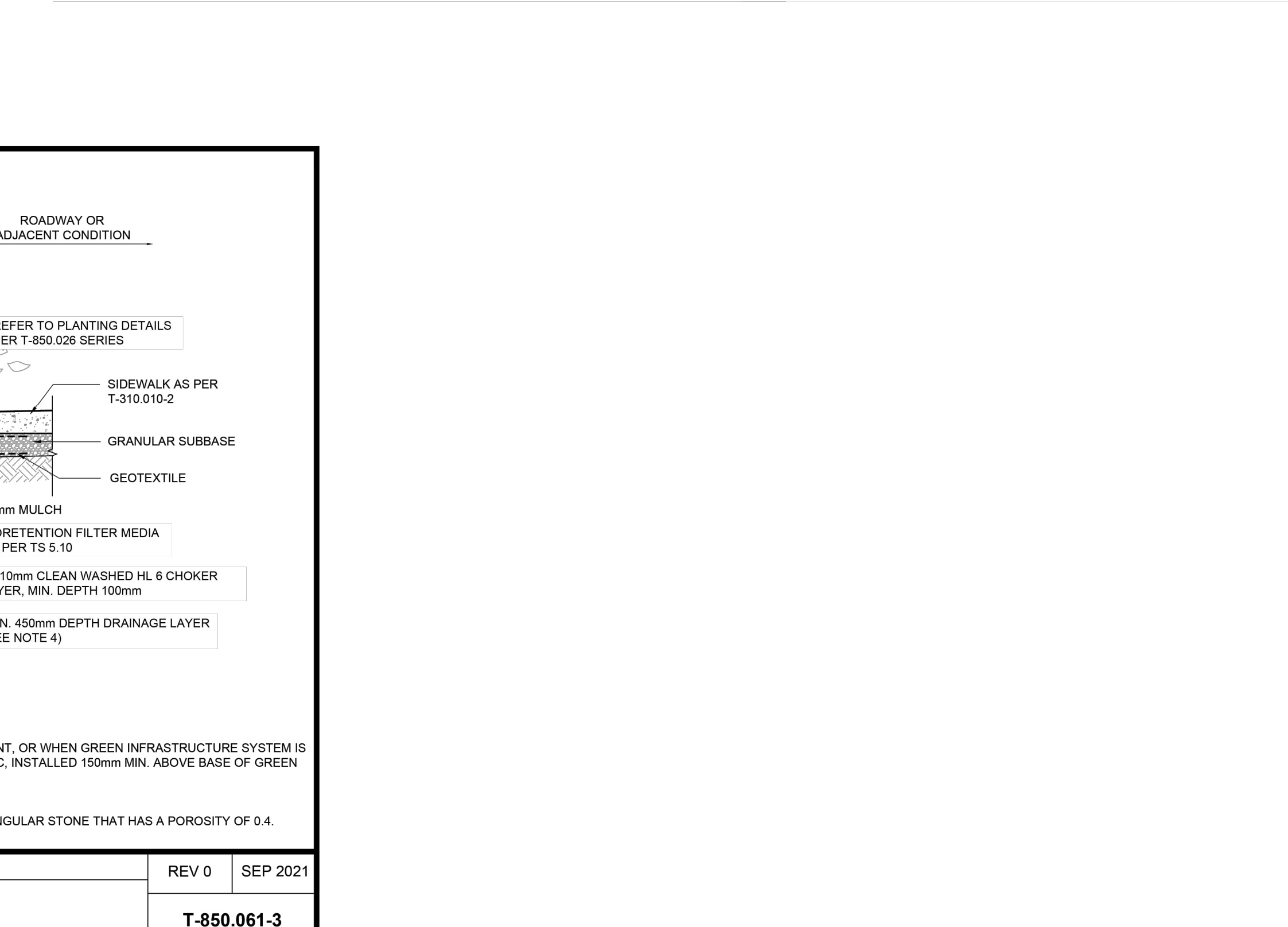
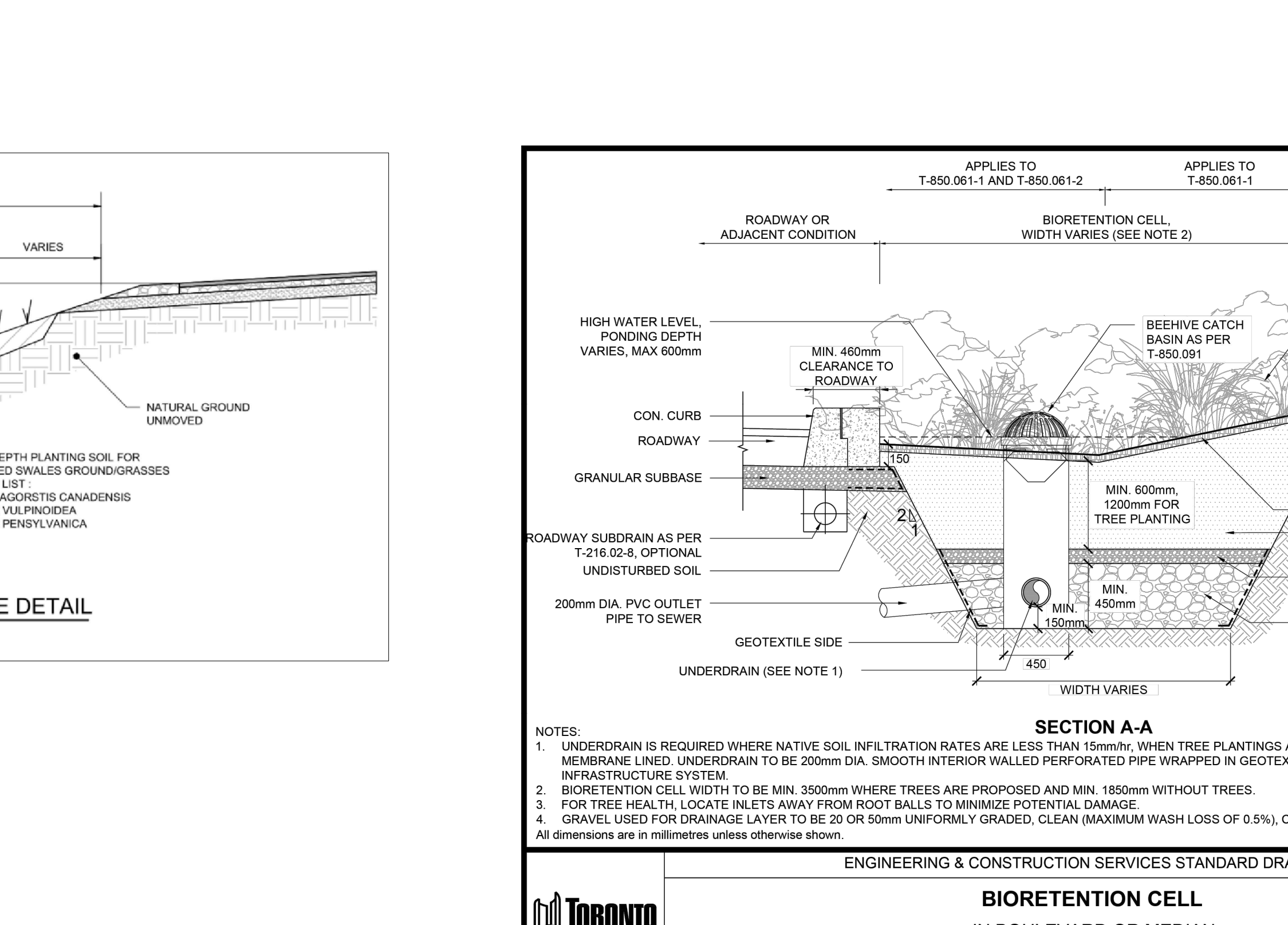
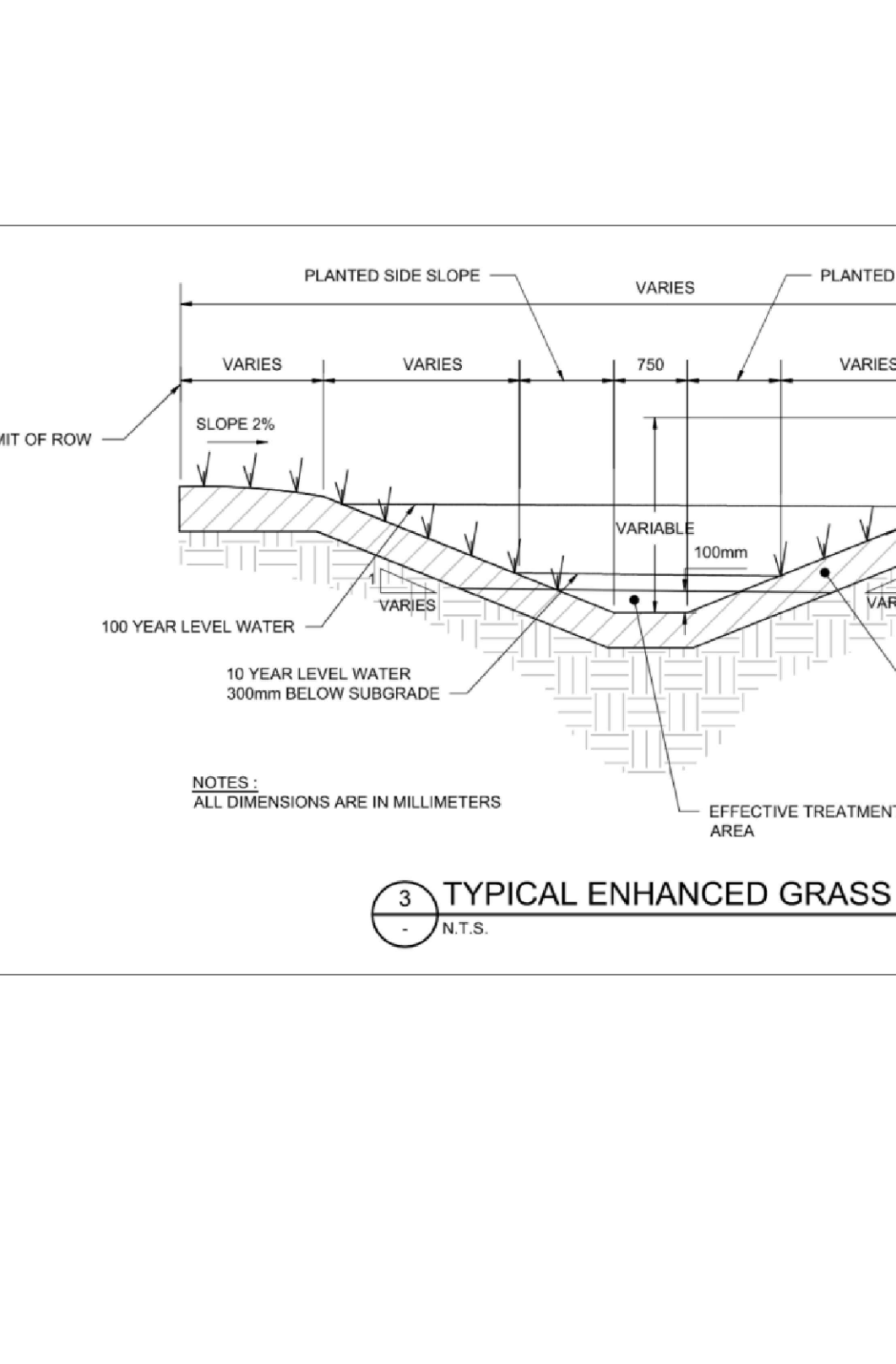
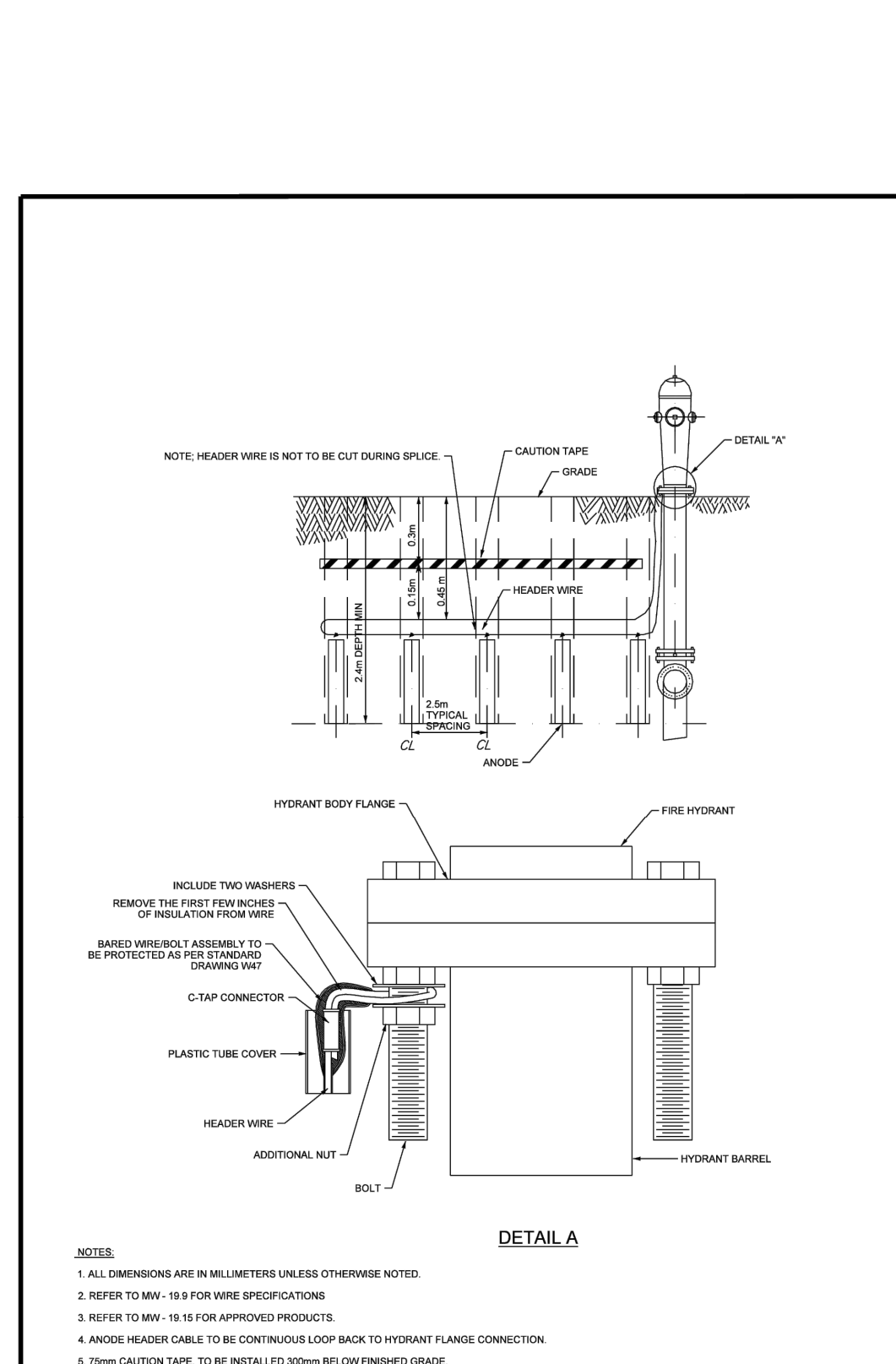
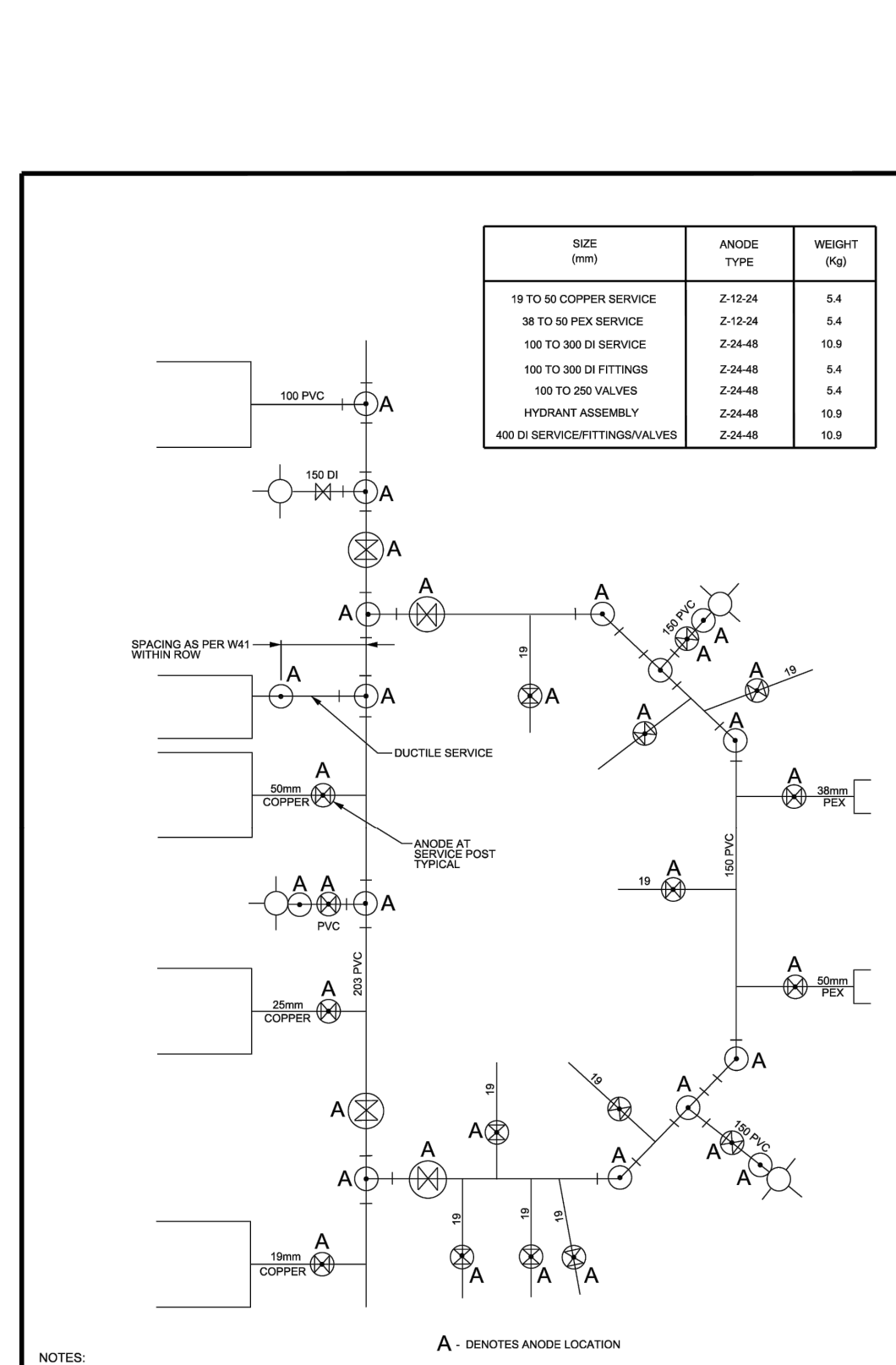
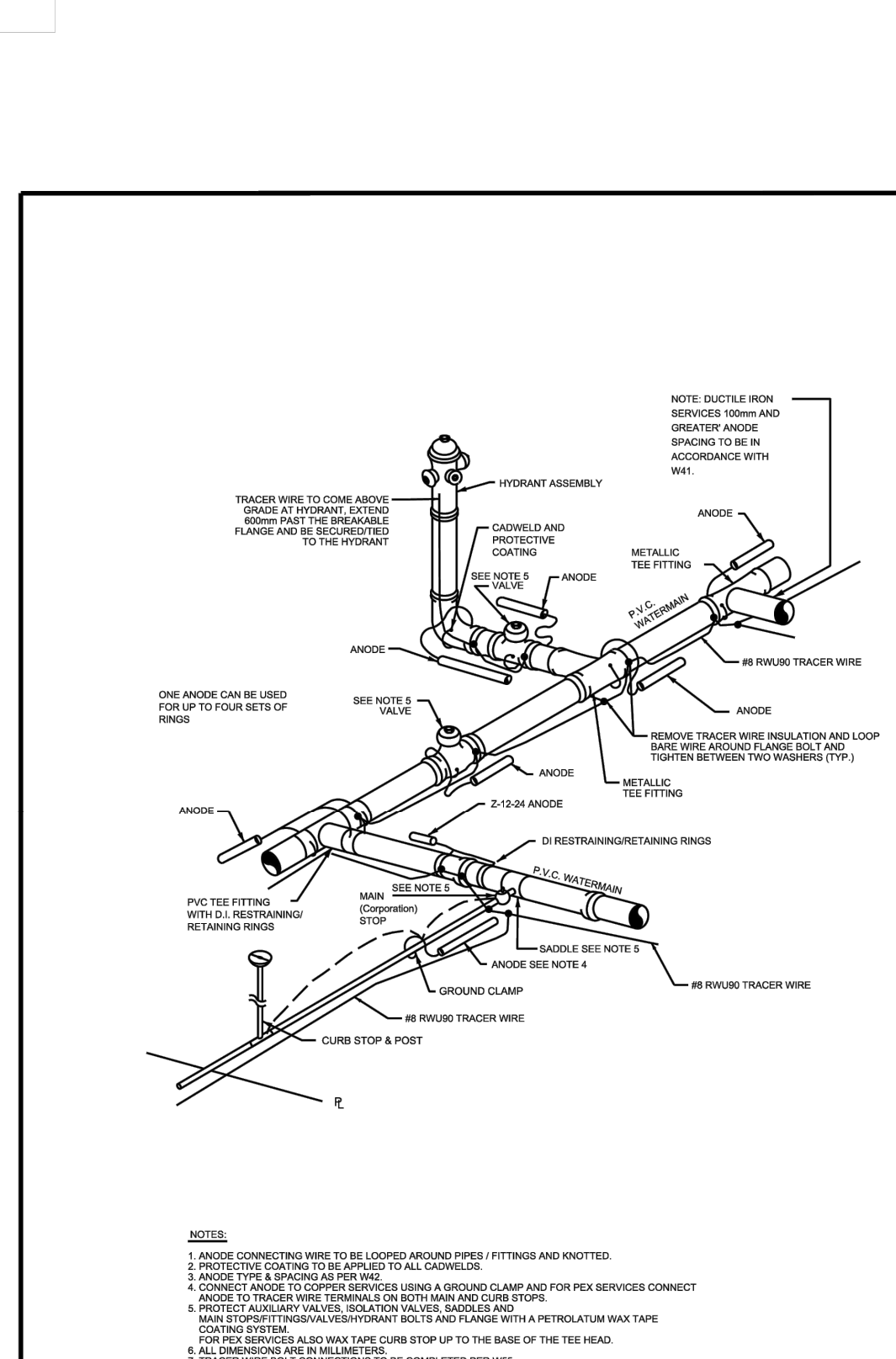
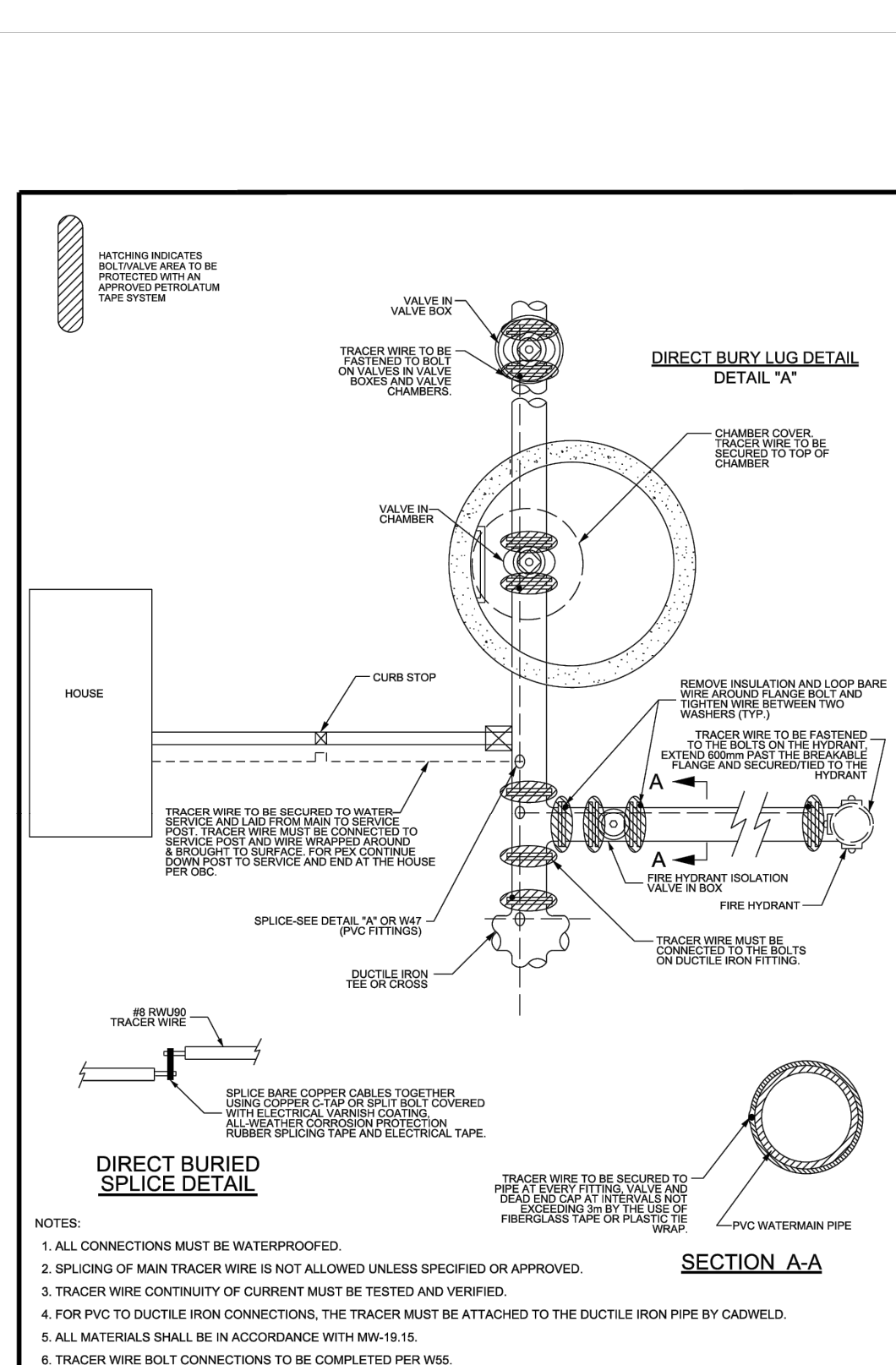
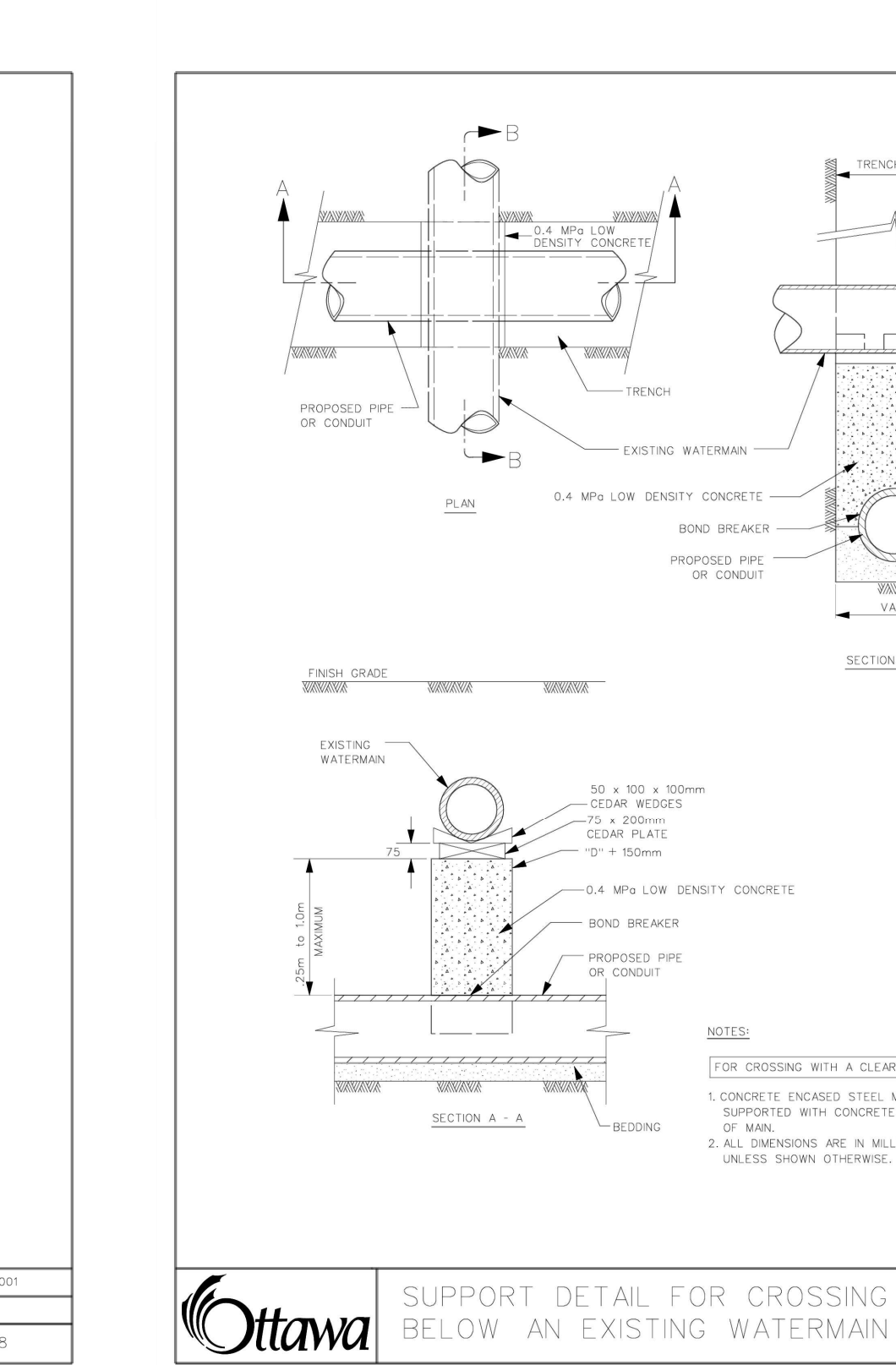
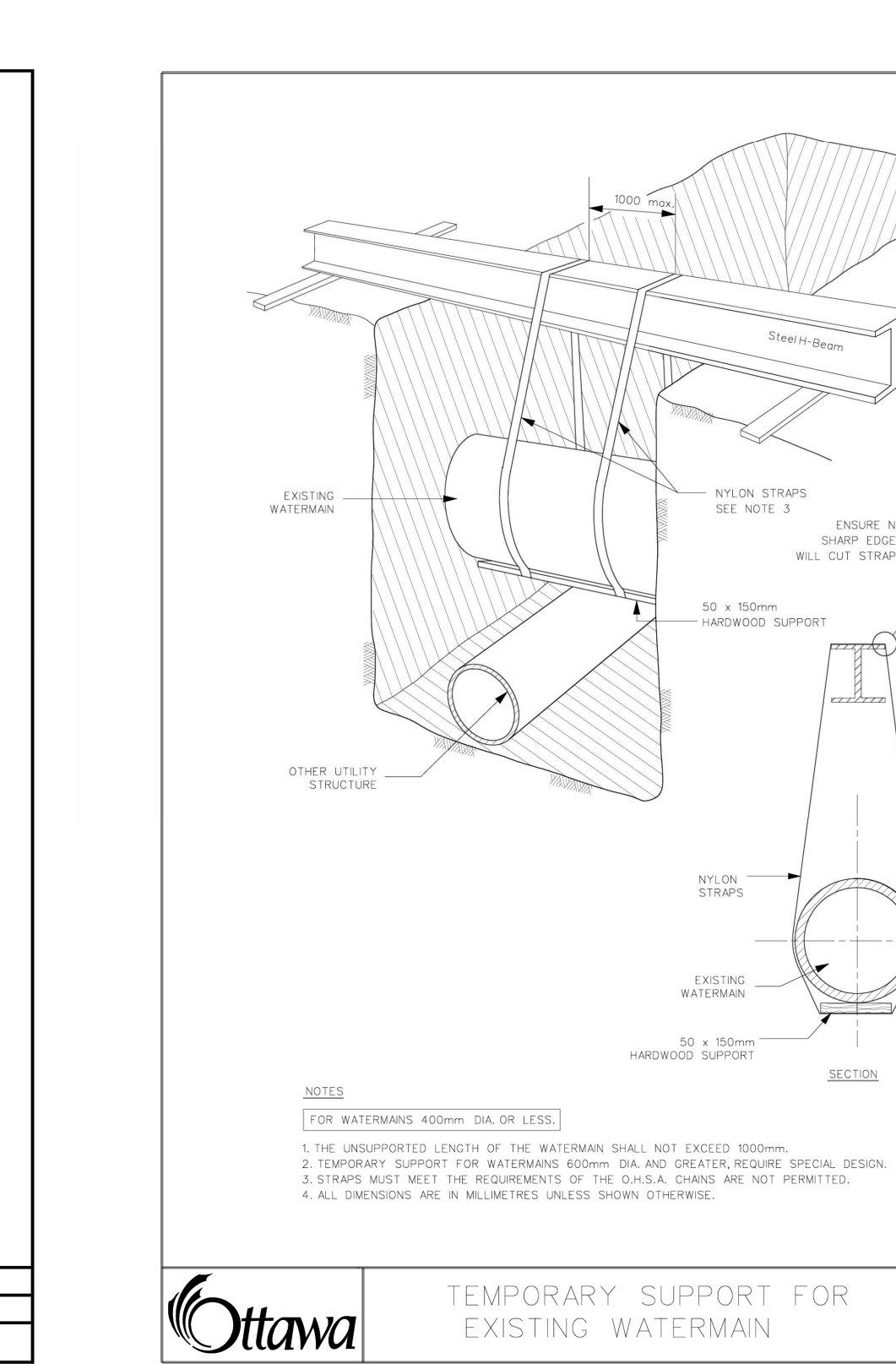

PROJECT: THE OTTAWA HOSPITAL NEW CAMPUS DEVELOPMENT - PHASE 4 MAIN HOSPITAL BUILDING. CLIENT: The Ottawa Hospital. PROJECT NO: 1070002. Includes a revision table and drawing information.

File Number: D07-12-26-0008 (Revision) D07-12-23-0168 (Original) Plan Number: 19424

DETAILS 2 OF 2. DRAWN: L. CURELY / B. NANDAL. CHECKED: C. GRAHAM. DATE: 2024-02-26. SCALE: 47 x 46". GRAPHIC SCALE: N.T.S.

C1-901 10