

## MEMO

---

**DATE** April 13, 2026 **PROJECT NO.** 1909-5877-5

**RE** Buildings A1 & A3, National Capital Business Park  
4055 Russell Road, City of Ottawa  
Transportation Impact Assessment Memorandum – 2<sup>nd</sup> Submission

---

**TO** Wally Dubyk, C.E.T.  
Transportation Project Manager, City of Ottawa

**FROM** Peter Apasnore, M.A.Sc., P.Eng, PTOE  
Aidan Hallsworth, P.Eng  
(C.F. Crozier & Associates Inc.)

---

Dear Wally,

C.F. Crozier & Associates Inc. (Crozier) was retained by National Capital Business Park LP to provide transportation engineering services in support of the development application for two proposed warehouse buildings. The development application is known as Buildings A1 & A3, located within a portion of Site 3, National Capital Business Park, City of Ottawa.

This Transportation Impact Assessment (TIA) Memo provides an update to previous work undertaken in support of the National Capital Business Park (NCBP) lands for the Buildings A1 & A3. A Master TIA for the full National Capital Business Park was prepared by Novatech in May 2020, which analyzed the transportation impacts of all NCBP sites, including the subject site, and Crozier also prepared a TIA for Site 3 in January 2022. Given that only minor changes have been made to the current site plan compared to those outlined in the NCBP Master TIA and particularly the overall Site 3 Crozier TIA, a full assessment of transportation impacts is redundant. Per the email correspondence between Wally Dubyk (City of Ottawa) and Aidan Hallsworth (Crozier), included in **Appendix A**, a TIA Memo with the agreed-upon scope was confirmed as sufficient to assess the transportation impacts associated with the Buildings A1 & A3 development proposal. The TIA Memo analyzes the following elements:

- Discussion on TIA Steps 1, 2.1 & 2.3
- TIA Step 3.1 – Trip Generation Forecasts during the weekday a.m. and p.m. peak hours;
- TIA Step 4 – Analysis
  - Site Access and Safety Review
  - Site Circulation Review
  - Parking Review
  - Boundary Street Design Review
  - Access Intersection Design Review

Following the original submission of this Memo (December 2025), Crozier received comments from Wally Dubyk of the City of Ottawa. The original Memo has been revised to address each of the provided City comments in this updated Memo submission. Included in **Appendix A** is a comment response matrix detailing how each of the municipal comments have been addressed.

## 1.0 BACKGROUND

Located within the City of Ottawa, the subject lands are bounded by Russell Road to the west, the Trans-Canada Highway to the east, a Hydro substation to the north, and a creek as well as Hunt Club Road to the south. The lands are designated "Industrial and Logistics" per the City of Ottawa Official Plan, reflecting the generally industrial nature of the surrounding areas. **Figure 1** outlines the site location.

Per the latest Site Plan prepared by McRobie Architects + Interior Designers (included as **Appendix B**), the proposed development consists of two warehouse buildings with office components. A combined Gross Floor Area (GFA) of 44,517 m<sup>2</sup> for Buildings A1 & A3 is proposed. The development proposes a surface parking lot with a total of 323 vehicle parking spaces, 28 bicycle parking spaces, and 8 oversized loading spaces. Three full-move access connections are proposed to Logistics Private Road (which ultimately connects to Russell Road), and a fourth full-move connection is proposed directly to Russell Road.

As previously noted, the site is located within the planned National Capital Business Park, an industrial business park development located along Russell Road. Previously, a Master Transportation Impact Assessment (NCBP Master TIA) was prepared for all three of the planned sites within the business park (Novatech, May 2020) and Crozier also prepared a TIA for Site 3 in January 2022. The NCBP Master TIA provided a comprehensive assessment of the transportation impacts associated with the planned developments, including the proposed development herein. Similarly, the Site 3 TIA by Crozier provided a more detailed assessment of anticipated impacts of development on the transportation network.

Within the NCBP Master TIA, the analysis assumed a development referred to as Site 3, Building A, consisting of a warehouse building with a GFA of 64,520 m<sup>2</sup>. In addition, the Crozier TIA prepared for Site 3 in January 2022 assumed a development referred to as Site 3, Building A1, consisting of a warehouse building and office space with a combined GFA of 59,323 m<sup>2</sup>. The current Buildings A1 & A3 development proposal has a smaller combined GFA of 44,517 m<sup>2</sup>. Therefore, in accordance with the scope established with City of Ottawa staff, this Transportation Impact Assessment (TIA) Memo reviews the development proposal through a trip generation forecast, a safety assessment of the proposed site accesses, and a review of the proposed parking supply to provide a current assessment of the Buildings A1 & A3 development in support of the development application.

Refer to **Appendix C** for relevant excerpts of the NCBP Master TIA and **Appendix D** for relevant excerpts of the Crozier Site 3 TIA conducted in January 2022.

## 2.0 SCREENING STEPS DISCUSSION

The City of Ottawa's *Transportation Impact Assessment (TIA) Guidelines* (2017) identify three triggers for completing a TIA report: Trip Generation, Location, and Safety. The screening assessment for each trigger is summarized below:

1. Trip Generation Trigger: For industrial developments, a minimum gross floor area (GFA) of 5,000 m<sup>2</sup> is required to satisfy this trigger. The proposed development for Buildings A1 & A3 has a total combined GFA of 44,517 m<sup>2</sup>; therefore, this requirement is satisfied.
2. Location Trigger: The site offers its main access connections via Russell Road. Based on a review of the City of Ottawa's GeoOttawa mapping, Russell Road is not designated as part of the City's Transit Priority Network, Rapid Transit Network, or Spine Bicycle Network. In addition, the site is not located within a Design Priority Area (DPA) or a Transit-Oriented Development (TOD) Zone). Therefore, the Location Trigger is not satisfied.
3. Safety Trigger: The posted speed limit on Russell Road is 80 km/h; therefore, the Safety Trigger is satisfied.

In summary, the development satisfies two of the three trigger criteria. A full TIA would typically be required if one or more triggers are satisfied. However, since multiple TIAs were previously completed for the site, including the Site 3 TIA which was primarily focused on the lands which encompass the proposed development, a full-scope TIA update is assessed to be not required. A reduced-scope TIA Memo assessment has been prepared instead, in accordance with the requested scope from City staff.

The complete TIA Screening Form is included in **Appendix E**. Refer to **Appendix A** for email correspondence with the City on establishing the TIA Memo scope.

### **3.0 SCOPING DISCUSSION**

This section provides an overview of the existing and future transportation conditions surrounding the site. It summarizes the characteristics of nearby roadways, as well as the available pedestrian, cycling, and transit facilities. Any ongoing or planned transportation improvements in the area are also noted.

#### **3.1 Existing Conditions**

##### **3.1.1 Roadways**

The nearby roadways of Russell Road, Hunt Club Road, Hawthorne Road and Last Mile Drive were reviewed given their proximity to the subject lands. Descriptions of these facilities are outlined below:

- Russell Road is a two-lane (one lane per travel direction) undivided arterial and is classified as a truck route, permitting full loads. It runs in a northwest-southeast direction near the subject lands and has a posted speed limit of 80km/h. The City of Ottawa Official Plan identifies 30m right of way (ROW) protection for Russell Road between Hawthorne Road and the Greenbelt Boundary.
- Hunt Club Road is a four-lane divided arterial roadway and is classified as a truck route, permitting full loads. It runs east-west and has a posted speed limit of 80km/h.
- Hawthorne Road is a five-lane undivided arterial roadway and is classified as a truck route, allowing full loads. It runs north-south and has a posted speed limit of 70km/h. The road has two lanes per travel direction and a two-way left turn median lane.

- Last Mile Drive is a two-lane (one lane per travel direction) undivided collector roadway. It runs east-west near the subject lands and has a posted speed limit of 50km/h.

### 3.1.2 Pedestrian and Cycling Facilities

Russell Road has gravel shoulders on both sides but does not provide any dedicated pedestrian or bicycle facilities. Hunt Club Road has a pedestrian sidewalk on the north side of the roadway between the Hydro-Ottawa right in right-out access and Hawthorne Road. Hawthorne Road has a bicycle lane and a pedestrian sidewalk on both sides of the roadway. Last Mile Drive has paved shoulders but also does not provide any dedicated pedestrian or bicycle facilities.

### 3.1.3 Transit

A single bus route by OC Transpo operates near the subject site on Russell Road. **Table 1** provides details regarding the existing bus route 47 operation.

**Table 1: Existing Transit Services**

Route	Span	Time of Operation	Peak Hour Headways	Bus Stops Near Site
Bus Route 47 (OC Transpo)	Hydro Road to St. Laurent Station	Monday to Friday 5:45 a.m. - 9:00 a.m. 3:00 p.m. - 6:25 p.m.	30 minutes	Stops for both travel directions within 200 m of the site

**Appendix F** contains the relevant transit network information.

### 3.1.4 Area Traffic Management

There are no Area Traffic Management measures within the study area nor are there any Area Traffic Management studies in progress.

## 3.2 Future Planned Conditions

Ottawa Council approved a new Capital Infrastructure Plan on July 23, 2025, guiding the city's road, transit, and active transportation investments through 2046. The approved plan reflects a "transit-first" philosophy: road investments are pursued only where transit alone would not suffice to meet demand. Per the updated Transport Mobility Plan (TMP), the need-based transit network identifies the addition of a transit priority corridor on Hunt Club Road between Riverside Drive and Conroy Road. When implemented, the corridor will provide faster, more reliable, and more convenient transit options, making it easier for employees across the city to reach the site. Refer to **Appendix G** for the 2025 TMP.

## 4.0 FORECASTING

This section compares the trip generation results from the NCBP Master TIA with the new site statistics to identify any changes in expected travel demand. The comparison helps determine whether the proposed development will have a different impact on the surrounding transportation network than previously anticipated.

#### 4.1 NCB Master TIA Trip Generation and Mode Share

Trip generation estimates were previously conducted for the proposed development identified as Site 3, Building A as part of the NCBP Master TIA. The ITE Trip Generation Manual, 10<sup>th</sup> Edition was used in the Master TIA to estimate vehicle trips. Person trips were derived using an ITE Vehicle-to-Person Trip conversion factor of 1.28, consistent with the City of Ottawa's TIA Guidelines. Finally, modal share targets from the Master TIA were estimated based on existing modal shares outlined in the 2011 TRANS O-D Survey Report, with minimal changes for future modal share changed being expected.

The trip generation results for the previous development scenario in the NCBP Master TIA are summarized in **Table 2**. Refer to **Appendix C** for NCBP Master TIA Trip Gen.

**Table 2: NCBP Master TIA Trip Generation and Modal Share**

Building (Units/GFA)	ITE Land Use Category	AM			PM		
		Trips Generated			Trips Generated		
		Inbound	Outbound	Total	Inbound	Outbound	Total
<b>Person Trips Generated – Site 3, Building A</b>							
Warehouse Building A (694,500 ft <sup>2</sup> )	LUC 156:High- Cube Parcel Hub Warehouse	470	469	<b>939</b>	631	297	<b>928</b>
<b>Person Trip by Modal Share – Site 3, Building A</b>							
Travel Mode	Target Modal Share	AM			PM		
		Trips Generated			Trips Generated		
		Inbound	Outbound	Total	Inbound	Outbound	Total
Auto Driver	70%	329	328	<b>657</b>	442	208	<b>650</b>
Auto Passenger	15%	70	70	<b>140</b>	95	44	<b>139</b>
Transit	10%	47	47	<b>94</b>	63	30	<b>93</b>
Active Trips	5%	24	24	<b>48</b>	31	15	<b>46</b>
<b>Total</b>	<b>100%</b>	<b>470</b>	<b>469</b>	<b>939</b>	<b>631</b>	<b>297</b>	<b>928</b>

Therefore, in the NCBP Master TIA, the development within the subject lands was projected to generated 939 and 928 two-way person trips in the weekday a.m. and p.m. peak hours, respectively.

#### 4.2 Crozier 2022 TIA Trip Generation and Mode Share

Trip generation estimates were previously conducted for the proposed development identified as Site 3, Building A1 as part of the NCBP Master TIA. The ITE Trip Generation Manual, 11<sup>th</sup> Edition was used in the Crozier TIA to estimate vehicle trips. Person trips were derived using an ITE Vehicle-to-Person Trip conversion factor of 1.28, consistent with the City of Ottawa's TIA Guidelines. Finally, modal share targets from the Master TIA were estimated based on existing

modal shares outlined in the 2011 TRANS O-D Survey Report, with minimal changes for future modal share changed being expected.

The trip generation results for the previous development scenario in the Crozier TIA are summarized in **Table 3**. Refer to **Appendix D** for Crozier TIA Trip Gen.

**Table 3: Crozier TIA Trip Generation and Modal Share**

Building (Units/GFA)	ITE Land Use Category	AM			PM		
		Trips Generated			Trips Generated		
		Inbound	Outbound	Total	Inbound	Outbound	Total
<b>Person Trips Generated – All Three Buildings</b>							
All Three Buildings (A1, A2 and B)	LUC 150: Warehouse	156	47	<b>203</b>	61	166	<b>227</b>
<b>Person Trips Generated – Site 3, Building A1</b>							
Warehouse Building A1 <sup>1</sup> <b>(638,550 ft<sup>2</sup>)</b>	LUC 150: Warehouse	108	33	<b>141</b>	42	115	<b>157</b>
<b>Person Trip by Modal Share – Site 3, Building A1</b>							
Travel Mode	Target Modal Share	AM			PM		
		Trips Generated			Trips Generated		
		Inbound	Outbound	Total	Inbound	Outbound	Total
Auto Driver	70%	76	23	<b>99</b>	29	81	<b>110</b>
Auto Passenger	15%	16	5	<b>21</b>	6	17	<b>23</b>
Transit	10%	11	3	<b>14</b>	4	12	<b>16</b>
Active Trips	5%	5	2	<b>7</b>	2	6	<b>8</b>
<b>Total</b>	<b>100%</b>	<b>108</b>	<b>33</b>	<b>141</b>	<b>42</b>	<b>115</b>	<b>157</b>

Note 1: Trip Generation of Building A1 is 69% of all three buildings combined, based on GFAs in the Crozier 2022 Site 3 TIA.

Therefore, in the Crozier 2022 Site 3 TIA, the development within the subject lands was projected to generate 141 and 157 two-way person trips in the weekday a.m. and p.m. peak hours, respectively.

### 4.3 New Site Stats Trip Generation and Mode Share

Trip generation for the proposed development was forecasted for the peak hours using the Institute of Transportation Engineers (ITE) Trip Generation Manual, 12<sup>th</sup> Edition and the City of Ottawa TRANS Trip Generation Manual given that the TRANS Trip Generation Manual does not have trip generation rates for employment type land uses.

The proposed development includes a combined 44,517 m<sup>2</sup> (478,210 ft<sup>2</sup>) of GFA within the two warehouse buildings. Therefore, this area was used for determining future trips at the site. LUC 150 “Warehouse” was applied to the warehouse building GFA, and the average rate methodology was applied for the forecast. Person trips were derived using an ITE Vehicle-to-

Person Trip conversion factor of 1.28, consistent with the City of Ottawa's TIA Guidelines and the NCBP Master TIA. Modal share targets from the NCBP Master TIA were reapplied for this person trip generation forecast. In addition to forecasting passenger vehicle trips, truck trips were also forecasted using a similar methodology to the ITE passenger vehicles forecast.

**Table 4** outlines the results of the ITE trip generation forecast for the proposed development.

**Table 4: New Site Stats Trip Generation and Mode Share**

Building (Units/GFA)	ITE Land Use Category	AM			PM		
		Trips Generated			Trips Generated		
		Inbound	Outbound	Total	Inbound	Outbound	Total
<b>Truck Trips Generated</b>							
Warehouse Buildings A1 & A3 <b>(478,210 ft<sup>2</sup>)</b>	LUC 150: Warehouse	5	5	<b>10</b>	5	5	<b>10</b>
<b>Vehicle Trips Generated- Building A1 &amp; A3</b>							
Warehouse Buildings A1 & A3 <b>(478,210 ft<sup>2</sup>)</b>	LUC 150: Warehouse	44	13	<b>57</b>	20	52	<b>72</b>
<b>Person Trips Generated- Building A1 &amp; A3</b>							
Warehouse Buildings A1 & A3 <b>(1.28 of Vehicle Trips)</b>	LUC 150: Warehouse	57	17	<b>74</b>	26	67	<b>93</b>
<b>Person Trip by Modal Share- Building A1 &amp; A3</b>							
Travel Mode	Target Modal Share	AM			PM		
		Trips Generated			Trips Generated		
		Inbound	Outbound	Total	Inbound	Outbound	Total
Auto Driver	70%	40	12	<b>52</b>	18	47	<b>65</b>
Auto Passenger	15%	9	2	<b>11</b>	4	10	<b>14</b>
Transit	10%	6	2	<b>8</b>	3	6	<b>9</b>
Active Trips	5%	2	1	<b>3</b>	1	4	<b>5</b>
<b>Total</b>	<b>100%</b>	<b>57</b>	<b>17</b>	<b>74</b>	<b>26</b>	<b>67</b>	<b>93</b>

Based on the ITE Trip Generation estimates, the proposed land use is forecasted to generate 74 and 93 total two-way vehicle trips during the weekday a.m. and p.m. peak hours, respectively. In addition, 10 truck trips are also projected during each of the weekday a.m. and p.m. peak hours.

### 4.3 Net Trip Generation

A net trip generation analysis compares the trips from the NCBP Master TIA and Site 3 TIA to those associated with the currently proposed Site A1 & A3 development. Two comparisons were made. The first comparison evaluates the trip generation results from the NCBP Master TIA using 10<sup>th</sup> Edition ITE vehicle trip generation rates, the Crozier Site 3 TIA prepared in January 2022 using 11<sup>th</sup> Edition ITE rates, and the currently proposed Site A1 & A3 development using 12<sup>th</sup> Edition ITE rates, reflecting the actual trip generation forecasts over time. The second comparison applies 12<sup>th</sup> Edition ITE vehicle trip generation rates consistently to both the NCBP Master TIA development scale and the current Site A1 & A3 development to provide a uniform and updated assessment. The details of the net trip generation during the weekday a.m. and p.m. peak hours for both person trips and vehicle trips are summarized in **Tables 5** and **6**. The net change between the proposed development and the development trips assumed in previous studies is also displayed in the corresponding previous study's row in brackets.

**Table 5: Net Person Trip Generation Comparison**

Building (Units/GFA)	ITE Land Use Category (Edition)	GFA	AM			PM		
			Trips Generated [Net Change to Current Dev.]			Trips Generated [Net Change to Current Dev.]		
			In	Out	Total	In	Out	Total
New Site Stats Trip Generation	LUC 150: Warehouse (12 <sup>th</sup> Edition)	478,210 ft <sup>2</sup>	57	17	<b>74</b>	26	67	<b>93</b>
NCB Master TIA Trip Generation	LUC 156: High-Cube Parcel Hub Warehouse (10 <sup>th</sup> Edition)	694,500 ft <sup>2</sup>	470 [-413]	469 [-452]	<b>939</b> [-865]	631 [-605]	297 [-230]	<b>928</b> [-835]
Crozier 2022 Site 3 TIA	LUC 150: Warehouse (11 <sup>th</sup> Edition)	638,550 ft <sup>2</sup>	108 [-51]	33 [-16]	<b>141</b> [-67]	42 [-16]	115 [-48]	<b>157</b> [-64]

**Table 6: Net Person Trip Generation Comparison (ITE 12<sup>th</sup> Edition Comparison)**

Building (Units/GFA)	ITE Land Use Category (Edition)	GFA	AM			PM		
			Trips Generated [Net Change to Current Dev.]			Trips Generated [Net Change to Current Dev.]		
			In	Out	Total	In	Out	Total
New Site Stat Trip Generation	LUC 150: Warehouse (12 <sup>th</sup> Edition)	478,210 ft <sup>2</sup>	57	17	<b>74</b>	26	67	<b>93</b>
NCB Master TIA Trip Generation <sup>1</sup>		694,500 ft <sup>2</sup>	82 [-25]	25 [-8]	<b>107</b> [-33]	37 [-11]	96 [-29]	<b>133</b> [-40]
Crozier 2022 Site 3 TIA Trip Generation <sup>1</sup>		638,550 ft <sup>2</sup>	76 [-19]	23 [-6]	<b>99</b> [-25]	35 [-9]	89 [-22]	<b>124</b> [-31]

Note 1: ITE Vehicle-to-Person Trip conversion factor of 1.28 was applied to ITE trips to result in person trips.

Based on the results in **Tables 5** and **6**, the proposed Site A1 & A3 development is expected to generate significantly fewer trips during the peak hours compared to the NCBP Master TIA (10th Edition) and the Crozier TIA prepared for Site 3 in January 2022 (11th Edition). This is primarily due to the use of updated ITE 12th Edition trip rates, which reflect lower trip generation for warehouse uses. When all developments are assessed using ITE 12th Edition rates, the Buildings A1 & A3 generate slightly fewer trips in comparison to previously assumed development statistics, consistent with their smaller combined GFA. Therefore, based on both comparisons, the forecasted trip generation is lower compared to prior reports. Therefore, additional traffic operational analysis is not required given the previous analyses undertaken in prior studies. A discussion on traffic operational issues and recommendations identified in the previous TIA studies which affect the proposed development are discussed in **Section 5.5**.

## **5.0 ANALYSIS**

The analysis section discusses the outcome of the transportation assessment process and identifies the necessary mitigation measures to support the development proposal, as required. The Analysis TIA step includes a transportation design review of the Site Plan, which considers the access configuration, parking supply, and internal site circulation for all applicable transportation modes.

### **5.1 Site Access Safety Review**

The development proposal includes two full-movement access directly onto Russell Road and three full-movement access points to Logistics Private Road (which ultimately connects to Russell Road). This section evaluates the suitability of these accesses from a transportation safety perspective and recommends mitigation measures, if warranted. The safety review considers whether turning maneuvers can be performed safely at each access, taking into account sight lines, intersection geometry, and spacing. The site access naming convention in this section is such that, Site Access A is Logistics Private Road, and the other proposed connection to Russell Road is Access B. Site Accesses #1 to 3 are the first to third accesses on Logistics Private Road, counting from Russell Road inward.

#### **5.1.1 Intersection Sight Distance**

Section 9.9 of the Transportation Association of Canada Geometric Design Guide for Canadian Roads (TAC GDGCR) provides intersection sight distance for different intersection control types. The calculated and design sight distances are further summarized in TAC GDGCR Tables 9.9.4, 9.9.6 and 9.9.12 for vehicles turning left from stop, turning right from stop, or turning left from the major road, respectively.

Case B1 (Left Turn from the Minor Road) and Case B2/B3 (Right Turn / Crossing Maneuver from the Minor Road) were used to evaluate sight line adequacy for the site accesses. A TAC WB-19 / WB-20 truck was used for the assessment at Site Access #A and #2 given these accesses are expected to accommodate large trucks. The Site Accesses #1, #3 and #B are meant to accommodate only passenger vehicles and thus a passenger car design vehicle was used for these cases. Finally, a design speed of 90 km/h was used for the Russell Road site access given the 80 km/h speed limit, while the remaining site accesses off of Logistics Private Road used a design speed of 50km/h, which is expected to be conservative for a private roadway.

**Table 7** summarizes the sight distance analysis for the proposed site accesses.

**Table 7: Intersection Sight Distance Assessment**

<b>Russell Road and Site Access #A (Logistics Private Road)</b>		
<b>Formula (TAC)</b>	<b>ISD = 0.278 * V<sub>major</sub> * t<sub>g</sub></b>	
<b>Feature</b>	<b>Case B1 – Left Turn/through</b>	<b>Case B2/B3 – Right Turn</b>
<b>Posted Speed</b>	80km/h	
<b>Design Speed (Assumed)</b>	90km/h	
Time Gap	11.5s	10.5s
Required Sight Distance	290m	265m
Available Sight Distance	>290m	>265m
<b>Russell Road and Site Access #B</b>		
<b>Formula (TAC)</b>	<b>ISD = 0.278 * V<sub>major</sub> * t<sub>g</sub></b>	
<b>Feature</b>	<b>Case B1 – Left Turn/through</b>	<b>Case B2/B3 – Right Turn</b>
<b>Posted Speed</b>	80km/h	
<b>Design Speed (Assumed)</b>	90km/h	
Time Gap	7.5s	6.5s
Required Sight Distance	105m	95m
Available Sight Distance	>200m	>200m
<b>Logistics Private Road and Site Access #1</b>		
<b>Formula (TAC)</b>	<b>ISD = 0.278 * V<sub>major</sub> * t<sub>g</sub></b>	
<b>Feature</b>	<b>Case B1 – Left Turn</b>	<b>Case B2/B3 – Right Turn</b>
<b>Posted Speed</b>	N/A	
<b>Design Speed (Assumed)</b>	50km/h	
Time Gap	7.5s	6.5s
Required Sight Distance	105m	95m
Available Sight Distance	45m <sup>1</sup>	>95m
<b>Logistics Private Road and Site Access #2</b>		
<b>Formula (TAC)</b>	<b>ISD = 0.278 * V<sub>major</sub> * t<sub>g</sub></b>	
<b>Feature</b>	<b>Case B1 – Left Turn</b>	<b>Case B2/B3 – Right Turn</b>
<b>Posted Speed</b>	N/A	
<b>Design Speed (Assumed)</b>	50km/h	
Time Gap	11.5s	10.5s
Required Sight Distance	290m	265m
Available Sight Distance	Functional <sup>1</sup>	Functional <sup>1</sup>
<b>Logistics Private Road and Site Access #3</b>		
<b>Formula (TAC)</b>	<b>ISD = 0.278 * V<sub>major</sub> * t<sub>g</sub></b>	
<b>Feature</b>	<b>Case B1 – Left Turn</b>	<b>Case B2/B3 – Right Turn</b>
<b>Posted Speed</b>	N/A	
<b>Design Speed (Assumed)</b>	50km/h	
Time Gap	7.5s	6.5s
Required Sight Distance	105m	95m
Available Sight Distance	165 m	185m

1. The limits of the intersection is less than required sight distance. No safety issues forecast given visibility of intersection, roadway limits and expected slower turning speeds.

Apart from the right-turn from the Site Access #2, all sight distance cases meet the applicable TAC-GDGCR sight distance requirements. Given the limits of Logistics Private roadway into the Russell Road intersection and the bend adjacent to the location of that access, the calculated required sight distance of 265m is not feasibly applicable in this scenario. Further, vehicles travelling at the intersection and bend will need to slow down. Therefore, no safety concerns related to sight distance constrains is forecast.

### 5.1.2 Access Spacing and Corner Clearance

The geometrics and spacings of the site accesses were reviewed as part of the Access Intersection Review. The requirements of the City of Ottawa Private Approach By-Law No. 2003-447 and the Transportation Association of Canada Geometric Design Guide for Canadian Roads (TAC-GDGCR) were used for the assessment.

**Tables 8 and 9** summarize the findings from the access review against the requirements of the City of Ottawa Private Approach By-Law No. 2003-447 and the TAC-GDGDCR Figures 8.8.2 and 8.9.2 for roadway frontage and access spacing, respectively. The larger of the two requirements in these manuals govern for the assessment and thus are displayed for the evaluation in **Table 9**.

**Table 8: Private Approach By-Law Roadway Frontage Evaluation**

Clause No.	Roadway (Frontage)	Maximum # of two-way private approaches	Satisfied?
S25.(1)(a-b)	Russell Road (~330m)	4	Yes (2 accesses)

**Table 9: Private Approach By-Law Access Spacing Evaluation**

Access	Viewing Direction relative to the Access	Distance Required to nearest Street / Private Access		Distance Provided to nearest Street / Private Access		Satisfied?
		Street	Access	Street	Access	
Site Access #A at Russell Road	North	70m <sup>1</sup>		>100m	>15m	Yes
	South			>100m	>15m	Yes
Site Access #B at Russell Road	North			>100m	>15m	Yes
	South			>100m	>15m	Yes
Site Access #1 at Logistic Private Road	North	30m <sup>2</sup>	15m <sup>2</sup>	N/A	>15m	Yes
	South			~30m	>15m	Yes
Site Access #2 at Logistic Private Road	North			N/A	>15m	Yes
	South			>70m	>15m	Yes
Site Access #3 at Logistic Private Road	North			N/A	>15m	Yes
	South			>100m	>15m	Yes

Note 1: The 70m requirement for access spacing along arterial roads (Russell Road) is per TAC-GDGCR Figure 8.8.2

Note 2: The 30m requirement for access spacing and 15m requirement for corner clearance is from S25.(1)(m) of the City of Ottawa Private Access By-law. The requirement for 100-199 parking spaces was applied for each access to reflect four accesses serving 522 vehicle parking spaces (~126 spaces per access).

The results of the access spacing and corner clearance evaluation demonstrate that the proposed spacings of the four site accesses are acceptable based on TAC-GDGCR and City of Ottawa By-Law requirements.

## 5.2 Site Circulation Review

Based on the vehicle maneuverability diagrams in **Appendix H**, drive-aisle width and parking lot space has been provided to allow for proper internal circulation. The site accesses have adequate radii to support the trucks expected at the site as shown on the Site Plan. The Site Plan shows feasible maneuverability for a WB-20 semi-trailer representing the most constrained vehicle profile expected onsite. Therefore, it is expected that the site accesses and the site itself will be functionally and operationally adequate based on the vehicle maneuvering diagrams displayed on the Site Plan.

## 5.3 Parking Review

The site is located in area “C – suburban” and the applicable zoning by-law parking requirements for the proposed development are summarized in **Table 10**. Section 101(7), Row N95 “Warehouse” of Table 101 of the City’s zoning by-law parking requirement was used to determine parking requirements for the entire site. Though there is small office spaces located within the warehouse building, these offices are expected to function as ancillary spaces to the main warehouse and will be used by warehouse employees. Therefore, no additional parking is calculated for the office components.

**Table 10: Parking Summary**

Land Use	Gross Floor Area (GFA)	By-Law Parking Rate	Total Parking Required	Parking Supply
Building A1 (Warehouse)	19,190 m <sup>2</sup>	0.8 per 100 m <sup>2</sup> for the first 5000 m <sup>2</sup> GFA, 0.4 per 100 m <sup>2</sup> thereafter	97 parking spaces	113 parking spaces
Building A3 (Warehouse)	25,327 m <sup>2</sup>		126 parking spaces	210 parking spaces
<b>Total</b>			<b>223</b>	<b>323</b>

The vehicle parking supply of 323 results in a surplus of 100 spaces compared to the City’s Zoning By-Law requirement for the site. Additionally, the site provides excess barrier free accessible parking spaces, bicycle parking spaces and loading spaces for each building compared to the By-Law requirements.

Further, in response to a comment received from the City of Ottawa, Crozier undertook supplementary proposed parking supply evaluation regarding the suitability of the proposed parking supply being more than the Zoning By-Law.

Firstly, it is noted that the proposed parking supply has been reduced compared to the previous submission. Further, according to the ITE Parking Generation Manual (6<sup>th</sup> Edition), the average parking demand for the applicable Land Use Code 150 “Warehousing” land use is 0.37 spaces / 1000ft<sup>2</sup> GFA, which corresponds to an expected parking demand of 177 spaces for the proposed development.

While this result on the surface does not appear to correlate with the parking rate and supply proposed development at 0.68 spaces / 1000ft<sup>2</sup> GFA and 323 spaces, respectively, this is due to warehouse parking demand significantly varying depending on warehouse type and operations. This is evident when considering the range of parking rates included in the LUC150 dataset, which range between 0.03 and 1.96 spaces / 1000ft<sup>2</sup> GFA. Additionally, ITE also provides a rate for 85<sup>th</sup> percentile parking demand, which can be used as an upper bound of parking supply for the site. This rate is 1.11 spaces / 1000ft<sup>2</sup> GFA, or significantly higher than the proposed development.

Therefore, based on the City of Ottawa parking requirements, ITE Parking Generation Manual findings, the proponent's input on expected warehouse operations, and the location of the site being outskirts of the city, the proposed parking supply is expected to be adequate in serving proposed development parking demands. The proposed excess parking supply compared to the Zoning By-Law is appropriate.

#### 5.4 Boundary Street Design

The boundary roadways of Russell Road and Hunt Club Road were evaluated using the City of Ottawa Multi-Modal Level of Service (MMLOS) Guidelines within the NCBP Master TIA. The results of this assessment have been re-summarized herein for convenience. It is noted that no change in the boundary roadways which would alter the MMLOS assessment has been recorded since the date of the NCBP Master TIA. As such, the assessment is still considered accurate as of the date of this memorandum.

The NCBP Master TIA MMLOS assessment included evaluation of the Pedestrian Level of Service (PLOS), Bicycle Level of Service (BLOS) and Truck Level of Service (TkLOS). Since neither Russell Road nor Hunt Club Road have been identified as a transit priority corridor, Transit Level of Service (TLOS) was not evaluated for the boundary roadways. **Table 11** summarizes the MMLOS assessment on the boundary roadways.

**Table 11: MMLOS Summary**

Roadway	Horizon	PLOS	BLOS	TkLOS
Russell Road	Existing	F	F	C
	Target	C	E	B
Hunt Club Road	Existing	F	E	A
	Target	C	C	B

The results of the MMLOS evaluation demonstrate that the PLOS and BLOS are deficient on both boundary roadways, while TkLOS on Russell Road may also need improvement. In order to improve the existing MMLOS to the desired, the following transportation infrastructure improvements as already captured in the previous Mater TIA may be considered by the City:

- Urbanization of Russell Road between Hawthorne Road and Hunt Club Road overpass. Urbanization may include reducing the posted speed limit from 80 km/h to 50 km/h and introduction of a pedestrian 2 m sidewalk (or 3 m multi-use path) and a 2 m boulevard.

- There already appears to be a sidewalk and an on-street cycling lane on Hunt Club Road for the segment west of Last Mile Drive, which should be satisfactory for the proposed site. Potential speed limit reduction for the subject segment may also be considered in future.
- For Russell Road, widening the lane widths to at least 3.7m to satisfy the TkLOS requirements.

Annex 1 of the City of Ottawa's Official Plan identifies a 30 m right of way (ROW) protection for Russell Road between Hawthorne Road and the Greenbelt boundary, and a 42.5m to 50m ROW protection for Hunt Club Road near Last Mile Drive. Therefore, the improvements identified above are feasible if the City chooses to implement them. If the noted improvements are implemented, the TIA LOS targets would be met.

### 5.5 Prior Traffic Operations Analysis Discussion

As noted in the prior study for the previous development occupying the subject lands, site generated traffic does not materially impact traffic operations, and no development specific improvements are required. Given the trip generation comparison, this finding is also expected to be true for the currently proposed development.

In prior traffic operations analysis considered within the NCBP Master TIA and in particular the more recent Site 3 TIA, traffic operations were found to be generally acceptable within the study area, with a few intersections operational constraints representative of typical urban commuter roads. Refer to the Approved Site 3 TIA Study excerpts included in **Appendix D**.

Importantly, the study notes how site generated traffic does not materially impact traffic operations, and no development specific improvements are required. Given the trip generation comparison, this finding remains applicable to the currently proposed development.

### 5.6 Clear Throat Length

To address the request of the City, additional evaluation of the site accesses' clear throat length was pursued in this TIA Memorandum resubmission. Clear throat length was evaluated according to Section 8.9.10 of the TAC-GDGCR. The clear throat length suggested requirements for the Light Industrial Land Use, under the development size range of 10,000m<sup>2</sup> to 45,000m<sup>2</sup>, were selected as this is the most similar land use category and size for the proposed development.

**Table 12** demonstrates the results of the evaluation, including a comparison to the planned available throat length. It is noted that despite the Site Accesses #1 to #3 intersecting with Logistics Private Road, which is a local road, the collector road requirements were applied for the evaluation given no local road clear throat length requirements exist.

**Table 12: Clear Throat Length Evaluation**

Access	Intersecting Street Type	Suggested Clear Throat Length Requirement	Clear Throat Length Available
Site Access #A (Logistics Private Road)	Arterial	30m	~17m
Site Access #B	Arterial	30m	~90m
Site Access #1	Collector	15m	~100m
Site Access #2	Collector	15m	~100m
Site Access #3	Collector	15m	~140m

Therefore, all site accesses apart from the Site Access #A (Logistics Private Road) meet the applicable TAC clear throat length requirements. Site Access #A is deficient of the clear throat length requirement due to the Site Access #1 intersection.

However, this is not expected to be an issue. This is due to both Logistics Private Road and Site Access #1 having significant queuing space after the point at which they intersect (at 60m and 140m, respectively), which is sufficient space to avoid upstream blocking and accommodate fluctuations in vehicular traffic. No incremental safety issues are expected to arise because of the lower clear throat length than typical, with clear sight lines being available at the Site Access #A (Logistics Private Road) and Site Access #1 intersection.

## 6.0 Conclusion and Recommendations

This Transportation Impact Assessment (TIA) Memorandum has assessed the transportation impacts of the proposed National Capital Business Park Buildings A1 & A3 industrial development within the 4055 Russell Road property in the City of Ottawa. The analysis contained within this Memo has resulted in the following key findings:

- The proposed Sites A1 & A3 development is expected to generate approximately 57 and 72 two-way passenger auto trips, 10 total two-way truck trips, and 74 and 93 total person trips during the weekday a.m. and p.m. peak hours, respectively. Compared to the previous NCBP Master TIA forecasts and Crozier 2022 TIA, these trips represent a reduction in trip generation during each peak hour. Therefore, the findings regarding traffic operations in the Approved Site 3 TIA remain applicable to this development.
- The updated 2025 Transportation Master Plan prioritizes transit improvements, reflecting a city-wide transit-first approach. The addition of a transit priority corridor on Hunt Club Road was proposed, which will enhance travel options by providing faster, more reliable, and more convenient transit access for employees across the city.
- The site accesses are all largely satisfactory of city functional requirements and expected to function adequately without major operational or safety concerns. While clear throat at the Logistics Private Road connection to Russell Road is deficient of TAC-GDGCR suggested standards, in practice the access is expected to operate adequately with significant queuing just beyond the Site Access #1 intersection on both Logistics Private Road and Site Access #1.
- The MMLOS assessment indicates deficiencies in pedestrian and cycling facilities on Russell Road and Hunt Club Road, with truck operations on Russell Road also needing

improvement. Implementing the recommended measures, including urbanization, lane widening, and reducing the speed limit on Russell Road, along with maintaining or enhancing facilities and considering speed adjustments on Hunt Club Road, would address these issues and achieve the target MMLOS. These improvements are feasible given the available right-of-way.

- Similar to the approved Site 3 TIA study, site generated traffic does not materially impact traffic operations, and no development specific improvements are required. Given the trip generation comparison, this finding is also expected to be true for the currently proposed development.

The development proposal can be supported from a traffic operations and safety perspective given the findings of this TIA Memo. The nearby transportation network is expected to adequately accommodate travel demands from the development proposal, including for non-vehicular travel modes. Furthermore, no functional or safety concerns from a transportation perspective were identified.

We trust that this TIA Memo addresses any transportation concerns related to the development proposal. Should you have any questions or wish to discuss further, please feel free to give us a call.

Sincerely,

**C.F. CROZIER & ASSOCIATES INC.**

**DRAFT**

Peter Apasnore, M.A.Sc., P.Eng., PTOE  
Project Manager, Transportation

/IA/AH/pa

Encl.

Figures:

Figure 1 – Site Location

Appendices:

Appendix A – Correspondence and Comment Responses

Appendix B – Site Plan

Appendix C – National Capital Business Park Background TIA Excerpts

Appendix D – Crozier 2022 TIA

Appendix E – TIA Screening Form Excerpts

Appendix F – Transit Network Information

Appendix G – 2025 Transport Mobility Plan

Appendix H – Vehicle Maneuverability Diagrams

J:\1900\1909-Avenue 31\5877 - 4055 Russell Rd\Reports\TIA-BuildingsA1\_A3

**C.F. CROZIER & ASSOCIATES INC.**

**DRAFT**

Aidan Hallsworth, P.Eng  
Project Engineer, Transportation

# APPENDIX A

## Correspondence

Complete	Transportation Impact Assessment	Dated 12/19/25	Information	Wally Dubyk	The quantity of parking spaces proposed is not seen to align with the trip generation forecasts and is more than double the minimum requirement as per by-laws. Consider reducing the number of parking spaces to meet the expected parking demand without providing excess parking. Otherwise, review the trip generation to assure alignment with the forecasted parking usage.	Acknowledged. The parking supply is in excess of the ZBL but is consistent with typical parking demands for such uses, particularly located in the outskirts of the City with low transit. This is further highlighted by similar ITE parking demand estimates. Refer to <b>Section 5.3</b> of the updated TIA Memo for further details.  The ITE trip generation are however for only typical commuter peak hours and is expected to be much lower than the overall traffic throughout the day that accumulates on site.
Outstanding	Site Plan	SPA-01 Rev. 05	Mandatory for Approval	Wally Dubyk	Provide pathways and crosswalks from all parking areas to the nearest building entrances to improve safety.	Noted and captured on the latest site plan.
Outstanding	Site Plan	SPA-01 Rev. 05	Mandatory for Approval	Wally Dubyk	To encourage and support the transit trips forecasted, provide a bus pad for bus stop ID 3335 located on Russell Rd along the site frontage. Provide a pathway connection from the bus stop to the closest main building entrance. Alternative locations in consultation with Transit Services for Stop 3335 can be considered should they better align with the site frontage.	Noted. A pad is currently already provided at the intersection of Russell Road and Logistics Private (main access).
Outstanding	Site Plan	SPA-01 Rev. 05	Mandatory for Approval	Wally Dubyk	On Appendix H, outbound trucks appear to encroach on the opposing east-bound traffic lane on Russell Road. Please clarify if this is the case and illustrate what would be required to ensure that trucks do not encroach on opposing lanes. The posted 80km/h speeds and arterial road designation pose a safety concern for overlapping movements on Russell Road.	Noted. This is an existing access and designed to typical TAC standards. Truck encroachment to opposing lanes is common and similar to most of the accesses along the road and in the area. Trucks are expected to wait for sufficient gaps to make the maneuver similar to a left turn that encroaches both lanes.  Further, the site is considering LCV trucks as well. Therefore, truck aprons will ultimately be considered as well to accommodate LCVs.
Outstanding	Transportation Impact Assessment	Dated 12/19/25	Mandatory for Approval	Wally Dubyk	Section 5.1.1: Intersection Sight Distance The access name convention is not clear. Is Access #A meant to represent the intersection of Russell/Logistics and Access #B located at the southwest of the site? "A TAC WB-19/WB-20 truck was used for the assessment at Site Accesses #A and #B given these accesses are expected to accommodate large trucks." This sentence appears to contradict Appendix H turning movement whereby large trucks use Logistic Private access. Table 7 shows that Russell Road and Site Access #B has a 7.5 second time gap and 6.5 second time gap for left turn from minor road and right turn from minor road. This gap applies to Passenger Car not a WB-WO. This contradicts the description above. For clarity, provide a plan in	Access A refers to Logistics Private and Access B refers to the other access connection to Russell Road (north-west side).  <b>Section 5.1.1.</b> has been updated to clarify that WB-20 truck traffic is only through Logistics Private. Table 7 has been updated accordingly.
Outstanding	Transportation Impact Assessment	Dated 12/19/25	Mandatory for Approval	Wally Dubyk	Section 5.2 Circulation and Access Note that comments provided in previous memo 17129 have not been addressed. The response to previous comment provided about truck turning templates within Appendix H (now Appendix I) is not accepted. It is not acceptable to use opposing traffic lanes on an arterial truck route to exit an industrial site with frequent truck usage. When illustrating these movement, heavy vehicles do not need to stay in the designated lane on the access and can use auxiliary lanes on the arterial that are traveling in the same direction. Provide all truck movements at both accesses and clearly show Russell Road dimensions with pavement markings and shoulders illustrated. Accesses may need truck aprons to designate travel area for most common vehicle use while still accommodating LCV trucks. LCV trucks may require special permits and further analysis. Contact the City's ROW office.	Noted. This is an existing access and designed to typical TAC standards. Truck encroachment to opposing lanes is common and similar to most of the accesses along the road and in the area. Trucks are expected to wait for sufficient gaps to make the maneuver similar to a left turn that encroaches both lanes.  Further, the site is considering LCV trucks as well. Therefore, truck aprons will ultimately be considered as well to accommodate LCVs.
Outstanding	Transportation Impact Assessment	Dated 12/19/25	Mandatory for Approval	Wally Dubyk	Provide turning templates for trucks.	Please refer to the additional swept paths included in Appendix H.
Outstanding	Transportation Impact Assessment	Dated 12/19/25	Mandatory for Approval	Wally Dubyk	Provide elevation of throat length for the accesses per the TAC.	This comment is interpreted to mean evaluating clear throat length of the site accesses. This has been provided in the updated TIA Memo in <b>Section 5.6</b> .

---

**From:** Dubyk, Wally <Wally.Dubyk@ottawa.ca>  
**Sent:** December 9, 2025 3:39 PM  
**To:** Aidan Hallsworth <ahallsworth@cfcrozier.ca>  
**Subject:** RE: National Capital Business Park (Buildings A1 & A3): TIA Letter Terms of Reference

Hi Aidan,

Please proceed with the Scope below and the TIA letter.

Thank you,

Wally Dubyk, Transportation Prj Mgr  
Transportation Engineering Services  
Planning, Development and Building Services Department  
110 Laurier Ave West | 4th Floor | Ottawa, ON | K1P 1J1  
City of Ottawa | Ville d'Ottawa  
[Wally.Dubyk@ottawa.ca](mailto:Wally.Dubyk@ottawa.ca)

Classified as City of Ottawa - Internal / Ville d'Ottawa - classé interne

---

**From:** Aidan Hallsworth <[ahallsworth@cfcrozier.ca](mailto:ahallsworth@cfcrozier.ca)>  
**Sent:** December 08, 2025 2:18 PM  
**To:** Dubyk, Wally <[Wally.Dubyk@ottawa.ca](mailto:Wally.Dubyk@ottawa.ca)>  
**Cc:** Peter Apasnore <[papasnore@cfcrozier.ca](mailto:papasnore@cfcrozier.ca)>  
**Subject:** National Capital Business Park (Buildings A1 & A3): TIA Letter Terms of Reference

**CAUTION: This email originated from an External Sender. Please do not click links or open attachments unless you recognize the source.**

**ATTENTION : Ce courriel provient d'un expéditeur externe. Ne cliquez sur aucun lien et n'ouvrez pas de pièce jointe, excepté si vous connaissez l'expéditeur.**

Good afternoon Wally,

Hoping you had an enjoyable weekend and are looking forward to the upcoming holiday season.

C.F. Crozier & Associates Inc. has been retained by National Capital Business Park LP to provide transportation engineering services in support of the Buildings A1 and A3 within the National Capital Business Park (NCBP) Site 3 development application. I assume that you are the contact person for this file given your responsibility on the Site 3B file, but if this is not correct, we'd appreciate if you could kindly forward to the appropriate person.

Background / Development Proposal / Screening

The site is 13.52 ha in size and is located in the western portion of 4055 Russell Road. The site occupies the southern portion of Site 3, National Capital Business Park. A Master TIA (by Novatech, dated May 2020) for the full NCBP, and the Site 3 TIA (by Crozier, dated January 2022), have both been completed and were signed off by the City. Both of these studies considered transportation impacts of development on the lands occupied by Buildings A1 & A3.

The development proposal (as outlined in the attached Plan) consists of:

- Two industrial warehouse buildings with the following development statistics:
  - Building A1 → Warehouse 19,120 m<sup>2</sup> GFA
  - Building A3 → Warehouse 25,327m<sup>2</sup> GFA
- A surface parking lot with 504 vehicle parking spaces, 28 bicycle parking spaces, and 9 oversized loading spaces.
- Three accesses are proposed to Logistics Private Road (which ultimately connects to Russell Road), and a fourth connection is proposed to connect with Russell Road directly.

The size of the development warrants a TIA (>5000m<sup>2</sup> GFA trip generation trigger). The speed limit safety trigger is also satisfied per the attached screening form.

However, a TIA Letter scope is being proposed for this development application. Given the previous analyses in both the NCBP Master TIA and the Site 3 TIA, a full TIA for this application would only replicate previous transportation analyses which are still applicable to this application. Therefore, traffic operations analysis will not be performed provided the trip generation comparison is satisfactory. In addition, the four site accesses are in the same locations as the Site 3 TIA, therefore this analysis (sight distance, access spacing) will be replicated from the Site 3 TIA into this TIA Letter.

A preliminary trip generation comparison is provided below to demonstrate how the development proposal is smaller scale than previous versions, meaning larger traffic operational impacts have already been assessed:

Development Component	Statistic	Peak Hour	Inbound Trips	Outbound Trips	Total Trips
National Capital Business Park Master TIA by Novatech (May 2020)					
Site 3, Building A	694,500 ft <sup>2</sup>	A.M.	470	469	939
		P.M.	631	297	928
Site 3 National Capital Business Park TIA by Crozier (January 2022)					

Building A1 (proportion of total Trip Gen)	638,550 ft <sup>2</sup>	A.M.	81	29	110
		P.M.	40	88	128
Buildings A1 & A3 – Current Development Proposal per attached Site Plan					
Building A1 & A3	478,210 ft <sup>2</sup>	A.M.	47	14	61
		P.M.	20	52	72

Please advise if the following scope is acceptable, or if modifications to the scope are required.

TIA Letter Proposed Scope

The following TIA modules are proposed to be completed in this letter:

- Module 1 → Outline the Screening Form and reduced scope TIA.
- Module 2.1 → Existing and Planned Conditions (Similar to Site 3 TIA)
- Module 2.3 → Complete the Exemptions Review. The following modules will be exempt: 4.1.3 New Street Networks, 4.2.2 Spillover Parking, 4.5 Transportation Demand Management
- Module 3.1.1 → Trip Generation and Mode Shares. Trip generation will be compared with that assumed in the NCBP Master TIA to demonstrate conformity and to confirm that traffic operations analysis is not necessary.
- Module 4.1.1 → Design for Sustainable Modes
- Module 4.1.2 → Circulation and Access. Vehicle maneuverability diagrams will be prepared. (Access evaluation similar to Site 3 TIA)
- Module 4.2 → Assess the proposed parking supply (autos, bicycles, and loading) according to the City of Ottawa ZBL requirements.
- Module 4.3 → Boundary Street Design
- Module 4.4 → Access Intersection Design (Access evaluation similar to Site 3 TIA)

We would greatly appreciate if you could provide feedback and confirm our proposed scope for the TIA Letter at the earliest opportunity so we can proceed with the letter. If there are any questions, please let us know.

Kind Regards,

**Aidan Hallsworth**, EIT  
 Engineering Intern, Transportation  
 Office: 905.693.4712  
 Collingwood | Milton | Toronto | Bradford | Guelph

**Proudly supporting our communities.**  
[Click to learn more.](#)



This email was sent on behalf of C.F. Crozier & Associates Inc. and may contain confidential and/or privileged information for the sole use of the intended recipient. If you have received this email in error, please contact the sender and delete all copies. Any review or distribution by anyone other than the intended recipient is strictly prohibited.

This e-mail originates from the City of Ottawa e-mail system. Any distribution, use or copying of this e-mail or the information it contains by other than the intended recipient(s) is unauthorized. Thank you.

Le présent courriel a été expédié par le système de courriels de la Ville d'Ottawa. Toute distribution, utilisation ou reproduction du courriel ou des renseignements qui s'y trouvent par une personne autre que son destinataire prévu est interdite. Je vous remercie de votre collaboration.

# APPENDIX B

## Site Plan

**SITE PLAN GENERAL NOTES:**

- ARCHITECTURAL SITE PLAN PROVIDED FOR REFERENCE ONLY. REFER TO CIVIL & LANDSCAPE FOR ALL SITE WORK
- ALL PROJECT GLAZING TO INCLUDE WHITE CERAMIC FRITTING IN A 5mm DOT PATTERN SPACED 50mm O.C. IN ALL DIRECTIONS IN COMPLIANCE WITH BIRD SAFE GUIDELINES
- EXCESS SNOW TO BE REMOVED FROM SITE
- INTERIOR GARAGE ROOM LOCATIONS SUBJECT TO SEPARATE INTERIOR FIT-UP APPLICATION (BY OTHERS)
- THE PROPERTY BOUNDARY INFORMATION WAS DERIVED FROM PLAN SR-5635 AND TAKEN FROM THE SURVEY PLAN PREPARED BY ANNIS, O'SULLIVAN VOLLEBEK INC DATED 2022-01-21

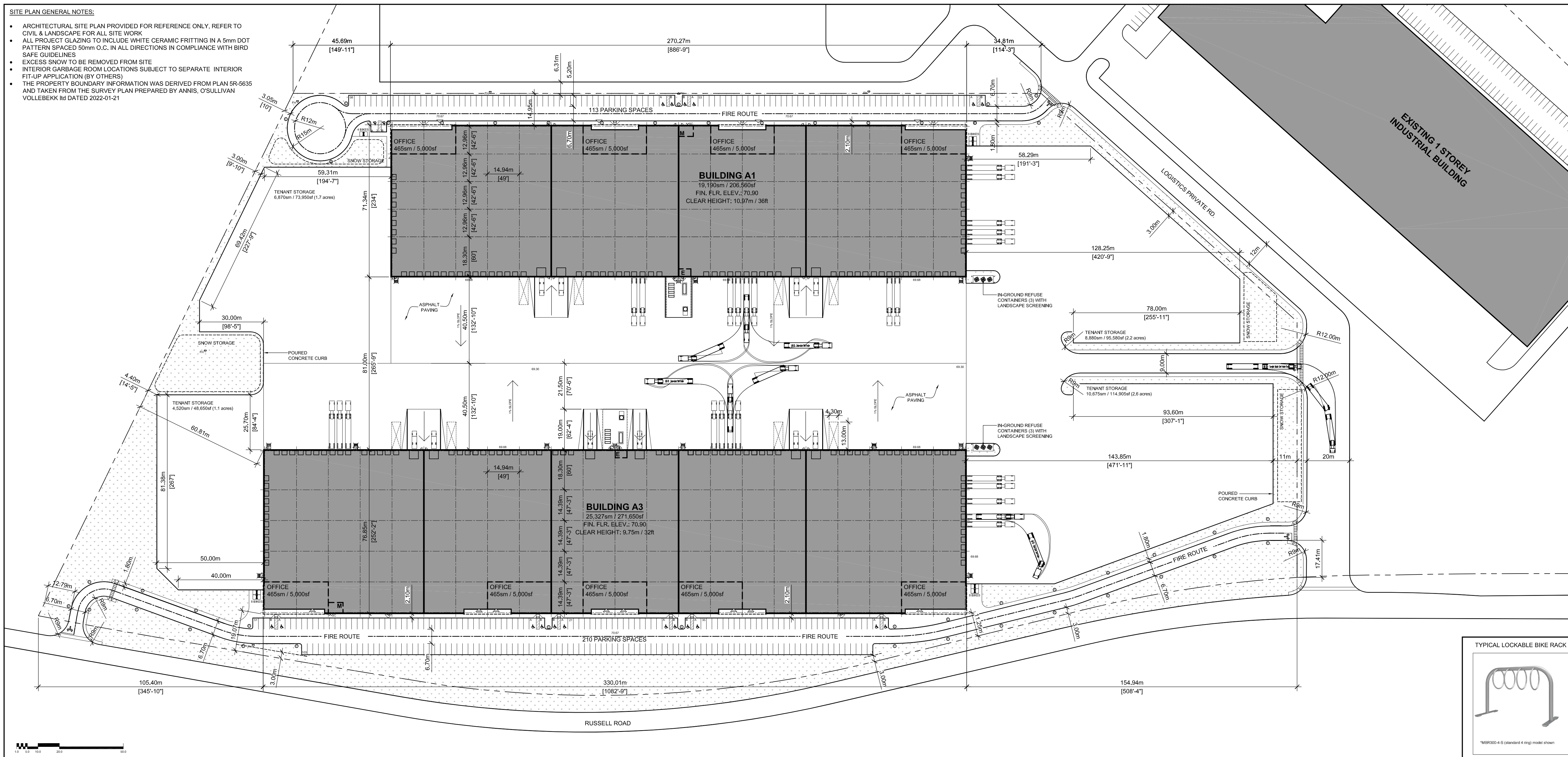

**CLIENT:**  
AVENUE 31 CAPITAL INC.

**REGISTERED OWNER:**  
Avenue 31 Capital Inc.  
801-250 City Centre  
Ottawa, ON K1R 6R7

**PLANNING CONSULTANT:**  
REPUBLIC URBANISM  
Montreal, QC

**CIVIL ENGINEER:**  
LRI ENGINEERING  
5430 Canotek Road  
Ottawa, ON K1J 9G2

**LANDSCAPE ARCHITECTS:**  
JAMES B. LENNOX & ASSOCIATES INC.  
3332 Carling Avenue  
Ottawa, ON K2H 5A8

**TRAFFIC ENGINEERING:**  
C.F. GROZIER & ASSOCIATES INC.  
211 Yonge Street, Suite 600  
Toronto, ON M5B 1M4

North

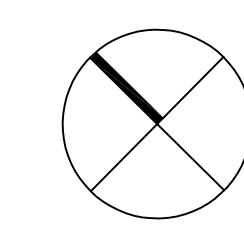

**Revisions**

No.	By	Description	Date
08	ERM	REVISED FOR COORDINATION	2025-12-02
09	ERM	REVISED FOR COORDINATION	2025-12-09
10	ERM	REVISED FOR COORDINATION	2025-12-10
11	ERM	ISSUED FOR SITE PLAN AMENDMENT	2025-12-19
12	ERM	REVISED FOR COORDINATION	2025-03-17
13	ERM	REVISED FOR COORDINATION	2025-03-18
14	ERM	REVISED FOR COORDINATION	2025-03-30

**04 SITE PLAN**

SPA-01 SCALE: 1:1000

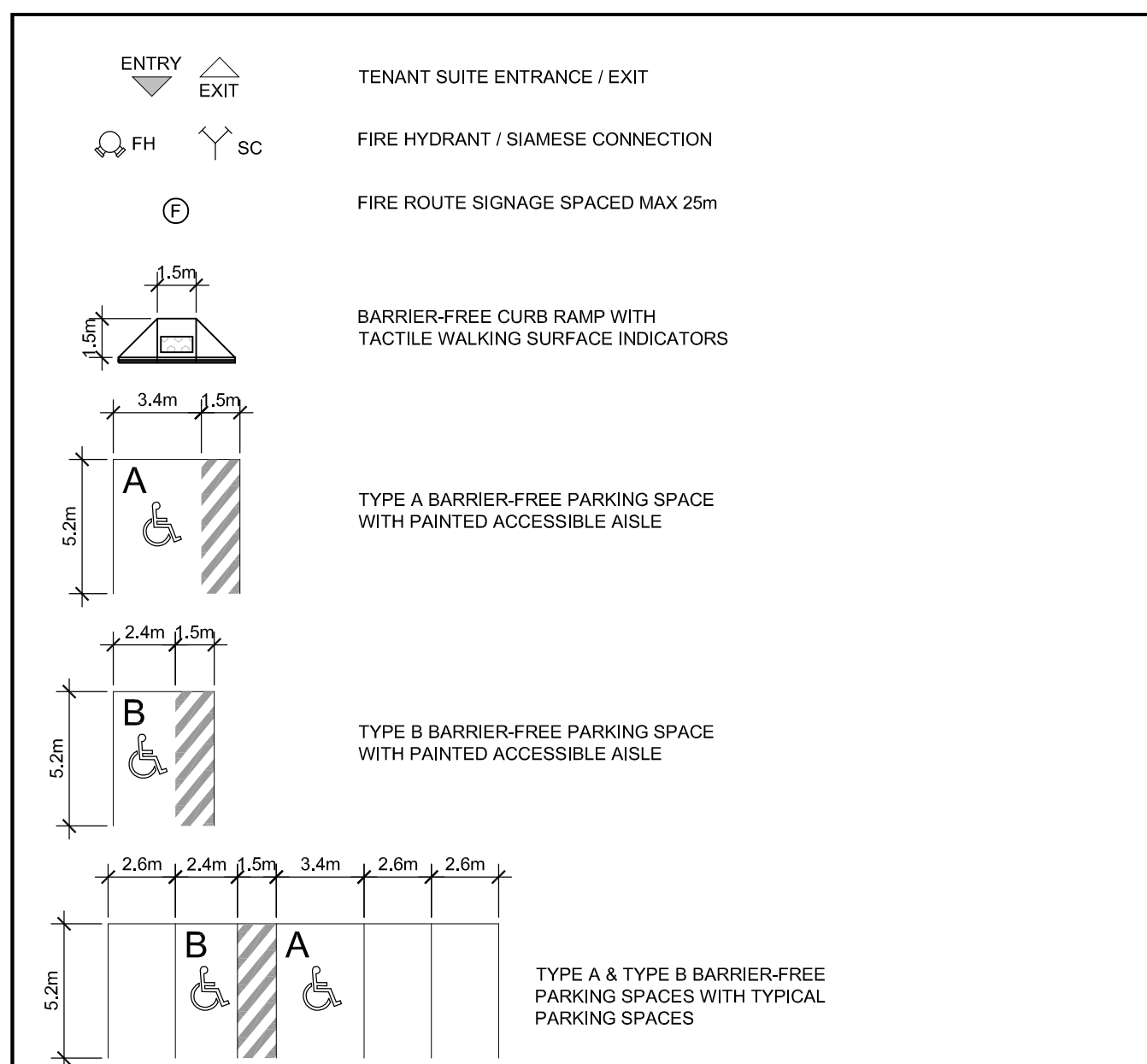

**03 DRAWING LEGEND**

SPA-01 SCALE:

ZONING MECHANISM: ZONING BY-LAW 2008-250 CONSOLIDATION	REQUIRED / PERMITTED	PROVIDED
ZONING: IH HEAVY INDUSTRIAL ZONE	WAREHOUSE HEAVY INDUSTRIAL LIMITED COMMERCIAL TRUCK TRANSPORT	WAREHOUSE (N95) HEAVY INDUSTRIAL (N42)
MINIMUM LOT AREA	0.4HA	13.31HA / 32.88 ACRES
MINIMUM LOT WIDTH	no minimum	IRREGULAR LOT SHAPE
MINIMUM FRONT YARD	7.5m	COMPLIANT WITH ZONING
MINIMUM CORNER SIDE YARD	7.5m	COMPLIANT WITH ZONING
MINIMUM INTERIOR YARD SETBACK	15m (abutting R or I zone) 7.5m	COMPLIANT WITH ZONING
MINIMUM REAR YARD	15m (abutting R or I zone) 7.5m	COMPLIANT WITH ZONING
MAXIMUM FLOOR SPACE INDEX	2	0.33 COMPLIANT WITH ZONING
MAXIMUM BUILDING HEIGHT	22m	BUILDING A1: 12.8m BUILDING A3: 12.8m
MINIMUM LANDSCAPE BUFFER WIDTH	7.5m (abutting R or I zone) 3m TYPICAL	COMPLIANT WITH ZONING

**02 SITE DATA AND ZONING INFORMATION**

SPA-01 SCALE:

ZONING MECHANISM: ZONING BY-LAW 2008-250 CONSOLIDATION	REQUIRED	PROVIDED
PARKING, TYPICAL - SECTION 101 AREA C	92 TYPICAL 2 TYPE A ACCESSIBLE 3 TYPE B ACCESSIBLE	105 TYPICAL 4 TYPE A ACCESSIBLE 4 TYPE B ACCESSIBLE
WAREHOUSE (N95) OR HEAVY INDUSTRIAL USE (N42): 0.8 SPACES PER 100sqm FOR FIRST 5,000sqm 0.4 SPACES PER 100sqm AFTER FIRST 5,000sqm	BUILDING A1: 19,190sqm BUILDING A3: 25,327sqm	121 TYPICAL 2 TYPE A ACCESSIBLE 3 TYPE B ACCESSIBLE
PARKING, BARRIER FREE - SECTION 112 (BYLAW 2017-301)	BUILDING A1: 19,190sqm	10 TYPICAL 12 TYPICAL
BICYCLE PARKING - SECTION 111	BUILDING A1: 19,190sqm	13 TYPICAL 16 TYPICAL
WAREHOUSE / HEAVY INDUSTRIAL 1 SPACE PER 200sqm	BUILDING A1: 19,190sqm	2 SPACES 4 OVERSIZED 13.4m X 4.3m
LOADING SPACE - SECTION 113 WAREHOUSE / HEAVY INDUSTRIAL	BUILDING A3: 25,327sqm	3 SPACES 4 OVERSIZED 13.4m X 4.3m

- BUILDING CLASSIFICATION:**
- 3.2.2.76 GROUP F, DIVISION 2, ANY HEIGHT, ANY AREA, SPRINKLERED
    - NON-COMBUSTIBLE CONSTRUCTION REQUIRED
    - FLOOR ASSEMBLIES SHALL HAVE A MIN 2hr FIRE RESISTANCE RATING
    - MEZZANINES SHALL HAVE A MIN 1hr FIRE RESISTANCE RATING
    - LOAD BEARING WALLS AND COLUMNS SHALL HAVE A FIRE RESISTANCE RATING NOT LESS THAN SUPPORTED ASSEMBLIES
  - 3.2.2.79 SPATIAL SEPARATION - TABLE 3.2.3.1.E
    - 15m MINIMUM SPATIAL SEPARATION FOR 100% AREA OF UNPROTECTED OPENINGS (EBF > 200m²)
    - 9m SPATIAL SEPARATION FOR 100% AREA OF UNPROTECTED OPENINGS WHEN FACING A STREET
  - 3.4.2.5 LOCATION OF EXITS
    - 45m MAXIMUM TRAVEL DISTANCE IF FLOOR AREA IS SPRINKLERED OR
    - PERIMETER EXITS SPACED MAX 60m ALONG PERIMETER OF FLOOR AREA

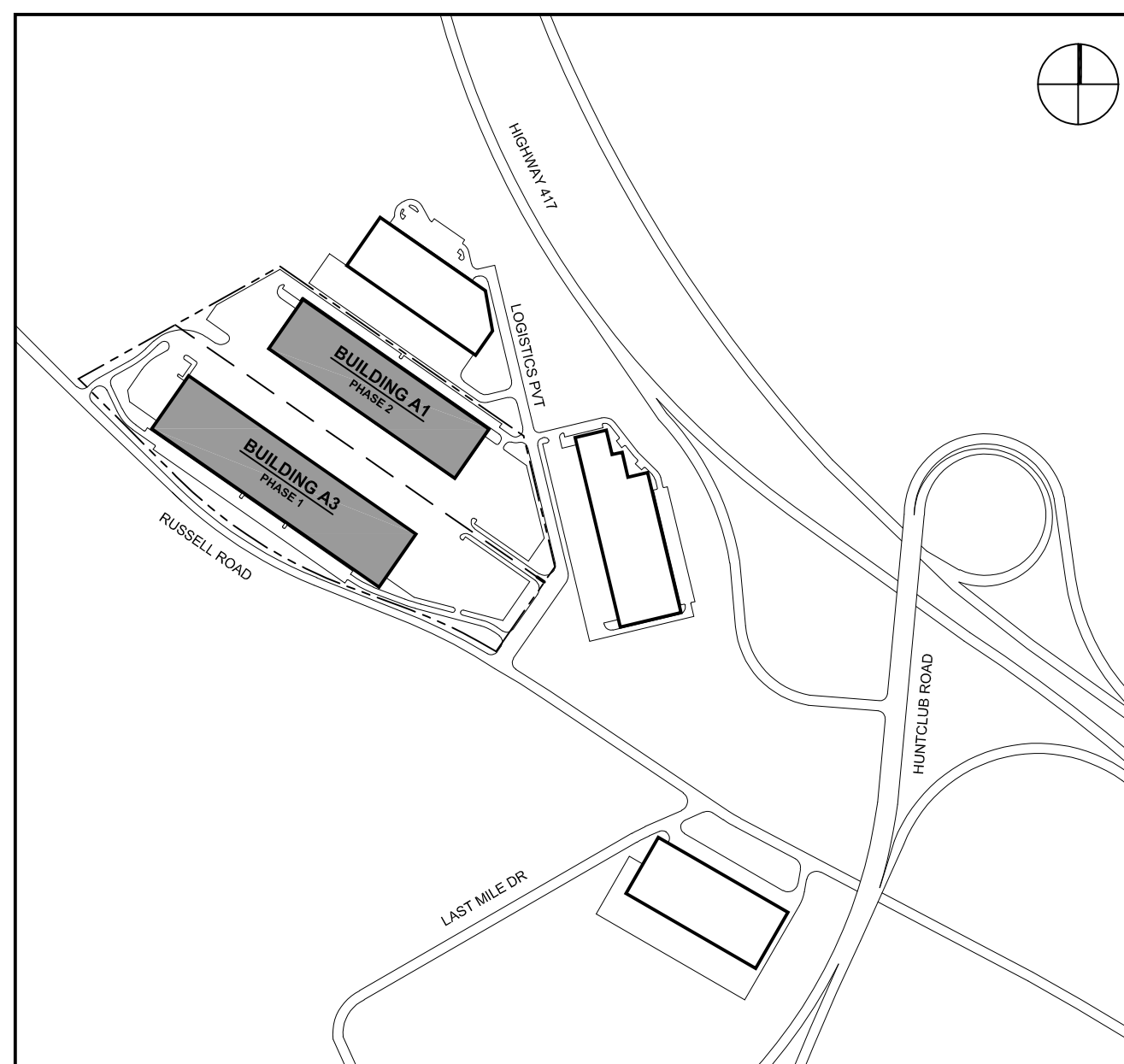

**01 LOCATION PLAN**

SPA-01 SCALE: NTS

Project

**NATIONAL CAPITAL BUSINESS PARK BUILDINGS A1 & A3**

4055 RUSSELL RD, OTTAWA

**Drawing LOCATION PLAN, ZONING REVIEW & SITE PLAN**

Scale AS NOTED Stamp

Drawn ERM

Checked ERM

Project No. 25-199  
Date NOV 2025

Drawing No.

**SPA-01**

PLAN NO. 1G431

# APPENDIX C

## National Capital Business Park Background TIA – Reports Excerpts

## Engineering

- Land / Site Development
- Municipal Infrastructure
- Environmental / Water Resources
- Traffic / Transportation
- Structural
- Recreational

## Planning

- Land / Site Development
- Planning Application Management
- Municipal Planning Documents & Studies
- Expert Witness (OMB)
- Wireless Industry

## Landscape Architecture

- Urban Design & Streetscapes
- Open Space, Parks & Recreation Planning
- Community & Residential Developments
- Commercial & Institutional Sites
- Environmental Restoration



# National Capital Business Park

## Traffic Impact Assessment

## 1.0 SITE LOCATION

This Transportation Impact Assessment (TIA) Forecasting report has been prepared in support of a Master Site Plan application for the National Capital Business Park at 4055 and 4120 Russell Road located west of the Hunt Club / Hwy 417 interchange (See **Figure 1**). Civic #4120 is vacant while civic #4055 includes a vacant farm as well as one single family dwelling.

The general area is characterized by a combination of various commercial and industrial land uses, including an existing hydro substation immediately north of 4055 Russell Road and a newly constructed Hydro Ottawa office just to the west of 4120 Russell Road.

**Figure 1: Site Location and Study Area**

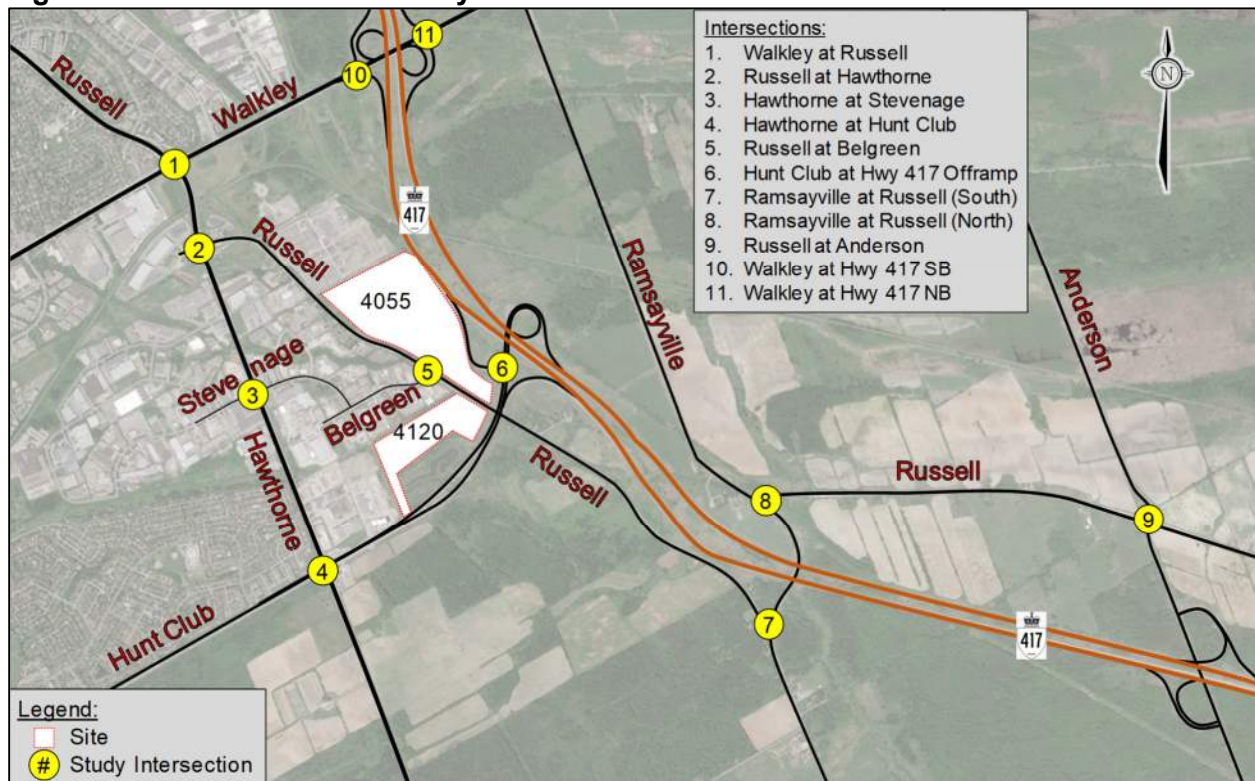

## 2.0 PROPOSED DEVELOPMENT

The subject sites are designated as 'Urban Employment Area' on Schedule 'B' of the City of Ottawa's Official Plan and zoned IH (Heavy Industrial). The proposed development (See **Appendix A**) is planned to be completed by 2023 and includes:

- Site 1- one warehouse with 8,325m<sup>2</sup> (89,610ft<sup>2</sup>);
- Site 2- two warehouses with 17,400m<sup>2</sup> (187,300ft<sup>2</sup>); and,
- Site 3- three warehouses with 75,685m<sup>2</sup> (814,700ft<sup>2</sup>).

The development is planned to include a total of about 976 parking spaces as well as loading bays and trailer drop spaces within each site. The concept includes six accesses to Russell Road and a connection to Hunt Club Road (Street 1).

## 5.0 Forecasting

### 5.1 Development-Generated Traffic

#### 5.1.1 Trip Generation

The proposed development is planned to be completed with three subareas consisting of:

- Site 1- one warehouse with 8,325m<sup>2</sup> (89,610ft<sup>2</sup>);
- Site 2- two warehouses with 17,400m<sup>2</sup> (187,300ft<sup>2</sup>); and,
- Site 3- three warehouses with 75,685m<sup>2</sup> (814,700ft<sup>2</sup>).

Trips generated by the proposed site development were estimated using *Trip Generation, 10<sup>th</sup> Edition* (Institute of Transportation Engineers, Washington, 2017). Person trips were estimated (See **Table 3**) using an ITE Trip to Person Trip conversion factor of 1.28, consistent with the City of Ottawa TIA Guidelines.

**Table 3: Person Trip Generation**

Land Use <sup>1</sup>	Units <sup>2</sup>	Person Trips Generated <sup>3</sup>					
		AM Peak Hour			PM Peak Hour		
		In	Out	Total	In	Out	Total
<b>Site 1</b>							
Warehouse (ITE 150)	89.6	35	11	46	13	36	49
<b>Site 2</b>							
Warehouse (ITE 150)	187.3	47	14	61	17	47	64
<b>Site 3</b>							
Warehouse (ITE 150)	120.2	39	12	51	15	39	54
High-Cube Parcel Hub Warehouse (ITE 156)	694.5	470	469	939	631	297	928
Total Development Trip Generation Sites 1-3		591	506	1097	676	419	1095
Notes: 1. Trip Generation for the associated Land Use from <i>Trip Generation 10<sup>th</sup> Edition</i> (Institute of Transportation Engineers, Washington, 2017). Trips have been increased by 28% to account for 10% non-auto mode share and average vehicle occupancy of 1.15. 2. Units are 1,000 ft <sup>2</sup> of GFA. 3. Person trips per hour for peak hours.							

The modal shares for the proposed development are anticipated to be generally consistent with the existing modal shares (See **Table 4**) outlined in the *2011 TRANS O-D Survey Report*, specific to the Hunt Club region which indicate the modal share values for the trips to/from and within the Hunt Club district. An increase to the auto driver share has been applied based on the location of the subject site, as the site is somewhat removed from significant residential development with minimal active transportation connections and transit service. The projected person trips by modal share for this full development are shown in **Table 4**.

**Table 4: Person Trips by Modal Share**

Travel Mode	Existing Modal Share	Target Modal Share	AM Peak			PM Peak		
			IN	OUT	TOT	IN	OUT	TOT
<b>Site 1</b>								
Person Trips			35	11	46	13	36	49
Auto Driver	60%	<b>70%</b>	<b>24</b>	<b>7</b>	<b>31</b>	<b>9</b>	<b>25</b>	<b>34</b>
Auto Passenger	15%	<b>15%</b>	5	2	7	2	5	7
Transit	15%	<b>10%</b>	4	1	5	1	4	5
Active Trips	10%	<b>5%</b>	2	1	3	1	2	3
<b>Site 2</b>								
Person Trips			47	14	61	17	47	64
Auto Driver	60%	<b>70%</b>	<b>33</b>	<b>10</b>	<b>43</b>	<b>11</b>	<b>33</b>	<b>44</b>
Auto Passenger	15%	<b>15%</b>	7	2	9	3	7	10
Transit	15%	<b>10%</b>	5	1	6	2	5	7
Active Trips	10%	<b>5%</b>	2	1	3	1	2	3
<b>Site 3</b>								
Person Trips			509	481	990	646	336	982
Auto Driver	60%	<b>70%</b>	<b>357</b>	<b>337</b>	<b>694</b>	<b>452</b>	<b>235</b>	<b>687</b>
Auto Passenger	15%	<b>15%</b>	76	72	148	97	50	147
Transit	15%	<b>10%</b>	51	48	99	65	34	99
Active Trips	10%	<b>5%</b>	25	24	49	32	17	49
<b>Total Development</b>								
Person Trips			591	506	1097	676	419	1095
Auto Driver	60%	<b>70%</b>	<b>414</b>	<b>354</b>	<b>768</b>	<b>472</b>	<b>293</b>	<b>765</b>
Auto Passenger	15%	<b>15%</b>	88	76	164	102	62	164
Transit	15%	<b>10%</b>	60	50	110	68	43	111
Active Trips	10%	<b>5%</b>	29	26	55	34	21	55

Full Buildout of the proposed development is estimated to generate 768 two-way vehicle trips during the AM peak hour and 765 two-way vehicle trips during the PM peak hour.

## 6.0 Analysis

### 6.1 Development Design

Conceptually, it is expected that pedestrian facilities will be provided between each building and the parking lots, to be reviewed at site plan for each site. New pedestrian walkways will be constructed, providing connectivity to Russell Road.

OC Transpo's service design guideline for peak period service is to provide service within a five minute (400m) walk of the home, school and work location of 95% of urban residents. The existing bus stops near the subject sites are described in **Section 4.1.3**.

Stops #3336 and 3339 are located in front of Buildings A and B. Stops #3335 and 3340 are less than 400m to Buildings C, D, and F. The distance between the stops and Building E is about 650m. Actual walking distance between exterior access doors and the transit stops will be measured and reviewed at site plan submission.

Each development block includes two connections to Russell Road to separate trucks and employees and have been aligned with opposing driveways where possible. Connections will be further reviewed at site plan.

Onsite turning paths of heavy vehicles and review of garbage collection and fire routes will also be reviewed at site plan.

### 6.2 Parking

The subject site is located in Area C on Schedule 1 and 1A of the City of Ottawa's ZBL. Minimum vehicular parking rates (0.8 / 100 m<sup>2</sup>) and bicycle parking rates (1 / 100 m<sup>2</sup>) for light industrial development are identified in the ZBL. The concept plan indicates sufficient vehicular parking within each of sites 1, 2, and 3, and the vehicular, accessible, and bicycle parking requirements for each building will be confirmed with the site plan submissions.

Minimum vehicle loading for light industrial are identified in the ZBL and indicate that for warehouse / light industrial uses, 1 space is required for buildings up to 9,999 m<sup>2</sup>, 2 spaces are required for sites up to 24,999 m<sup>2</sup>, and 3 spaces are required for sites over 25,000m<sup>2</sup>. Each building exceeds these minimum requirements, and this will be confirmed at site plan submission.

### 6.3 Boundary Streets

Schedule 'B' of the City of Ottawa's Official Plan indicates the site is in an Urban Employment Area. Targets for pedestrian level of service (PLOS), bicycle level of service (BLOS), and truck level of service (TkLOS) for Russell Road and Hunt Club Road reflect those outlined for an arterial road located within an employment area in Exhibit 22 of the MMLOS guidelines. Since neither boundary street is identified as a transit priority corridor, the transit level of service (TLOS) has not been evaluated. The Segment PLOS, BLOS, and TkLOS and associated targets for Russell Road and Hunt Club Road are summarized in

**Table 6.** Details on the Segment MMLOS are included in **Appendix G**.

**Table 6: Segment MMLOS Summary**

Intersection	PLOS	BLOS	TkLOS
Russell Road	F	F	C
<b>Target</b>	<b>C</b>	<b>E</b>	<b>B</b>
Hunt Club Road	F	E	A
<b>Target</b>	<b>C</b>	<b>C</b>	<b>B</b>

The PLOS along both Russell Road and Hunt Club Road fronting the site is currently failing. Both streets have 80km/h posted speed limits fronting the site and more than 3,000 vehicles per day AADT. Even if sidewalk were installed, the highest attainable PLOS score for each roadway is D due to the roadway speed and volume. Hunt Club Road fronting the site currently only leads to the Highway 417 ramps and has no pedestrian destinations. If Russell Road in this area is urbanized in the future and a reduced operating speed of 60km/h (posted 50km/h) is achieved, the City could include 2m sidewalk with 2m boulevard to achieve the PLOS target.

The BLOS along both Russell Road and Hunt Club Road fronting the site is currently failing. Without physically separated bikeways, the highest attainable BLOS score on both roadways is E due to the high operating speed. Hunt Club Road fronting the site currently only leads to the Highway 417 ramps and has no cycling destinations. The addition of on-street bicycle lanes along Russell Road would achieve the City’s BLOS target for that street. This is identified for the City’s consideration pending funding.

The TkLOS along Russell Road fronting the site misses the target B. To achieve the target TkLOS of B, 3.7m wide lanes are required. The existing gravel shoulders are approximately 2.5m. The City may wish to consider paving an additional 0.5m on either side of the road.

**6.4 Access Intersections**

The proposed development will be served by seven connections, six to Russell Road and one to Hunt Club Road. Each Russell Road driveway is intended to be STOP controlled with free flow traffic on Russell Road.

Signals are required at the connection to Hunt Club based on high approach intersection delay (See **Table 10**). The Street 1 connection to Hunt Club Road is proposed approximately 250m east of the Hydro Ottawa (signalized) access road. The location and ultimate functional design of this intersection have been agreed by the City of Ottawa in a tri-party agreement with NCC and Hydro Ottawa in 2016.

The driveway configurations with respect to design guidelines and requirements of the City’s Private Approach By-law will be reviewed at site plan submission for each site, however the following are noted:

- The Transportation Association of Canada (TAC) outlines minimum clear throat lengths for driveways based on the land use, development size, and type of roadway. For the proposed building sizes, the clear throat requirements are:
  - 60m for driveways to Building A (60m is provided);
  - 30m for driveways to Sites 1 and 2 (30m is provided);

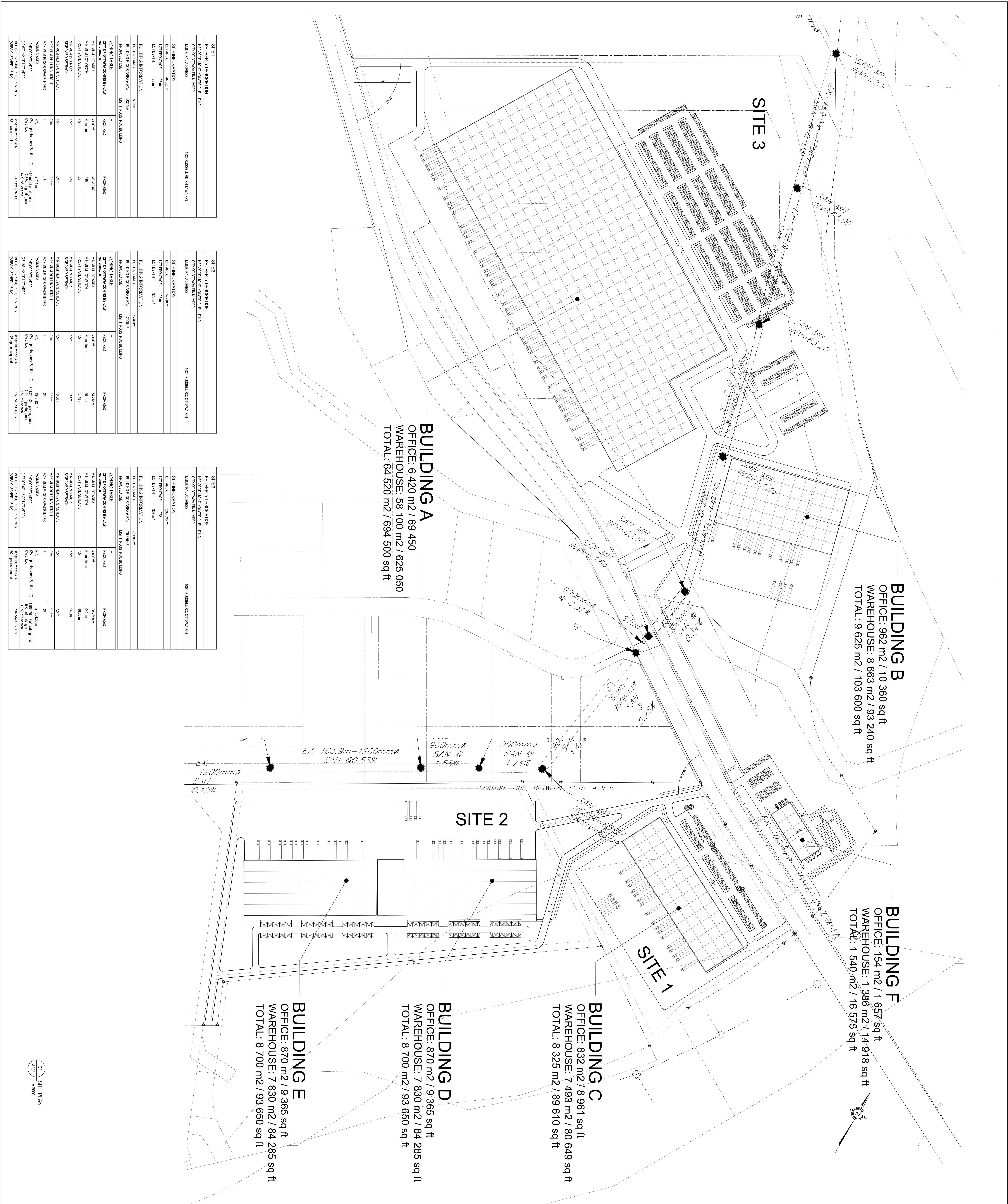

**BUILDING B**  
 OFFICE: 962 m<sup>2</sup> / 10 360 sq ft  
 WAREHOUSE: 8 663 m<sup>2</sup> / 93 240 sq ft  
 TOTAL: 9 625 m<sup>2</sup> / 103 600 sq ft

**BUILDING F**  
 OFFICE: 154 m<sup>2</sup> / 1 657 sq ft  
 WAREHOUSE: 1 386 m<sup>2</sup> / 14 918 sq ft  
 TOTAL: 1 540 m<sup>2</sup> / 16 575 sq ft

**BUILDING C**  
 OFFICE: 832 m<sup>2</sup> / 8 961 sq ft  
 WAREHOUSE: 7 493 m<sup>2</sup> / 80 649 sq ft  
 TOTAL: 8 325 m<sup>2</sup> / 89 610 sq ft

**BUILDING D**  
 OFFICE: 870 m<sup>2</sup> / 9 365 sq ft  
 WAREHOUSE: 7 830 m<sup>2</sup> / 84 285 sq ft  
 TOTAL: 8 700 m<sup>2</sup> / 93 650 sq ft

**BUILDING E**  
 OFFICE: 870 m<sup>2</sup> / 9 365 sq ft  
 WAREHOUSE: 7 830 m<sup>2</sup> / 84 285 sq ft  
 TOTAL: 8 700 m<sup>2</sup> / 93 650 sq ft

**BUILDING A**  
 OFFICE: 6 420 m<sup>2</sup> / 69 450  
 WAREHOUSE: 58 100 m<sup>2</sup> / 625 050  
 TOTAL: 64 520 m<sup>2</sup> / 694 500 sq ft

SITE 1	
<b>PROPERTY DESCRIPTION</b>	PROPOSED
<b>PROPOSED BUILDING</b>	PROPOSED
<b>CITY OF OTTAWA NUMBER</b>	4120 RUSSELL RD OTTAWA, ON
<b>MUNICIPAL ADDRESS</b>	4120 RUSSELL RD OTTAWA, ON
<b>SITE INFORMATION</b>	
<b>LOT NUMBER</b>	4828 m <sup>2</sup>
<b>LOT AREA</b>	4828 m <sup>2</sup>
<b>LOT DEPTH</b>	143 m
<b>BUILDING INFORMATION</b>	
<b>BUILDING AREA</b>	8234 m <sup>2</sup>
<b>BUILDING FLOOR AREA (GFA)</b>	8234 m <sup>2</sup>
<b>PROPOSED USE</b>	LIHTI INDUSTRIAL BUILDING
<b>ZONING TABLE</b>	
<b>No. of stories</b>	2
<b>MINIMUM LOT AREA</b>	4000 m <sup>2</sup>
<b>MINIMUM LOT WIDTH</b>	No minimum
<b>FRONT YARD SETBACK</b>	7.5m
<b>MINIMUM INTERIOR CLEARANCE</b>	2.5m
<b>MINIMUM SIDE YARD SETBACK</b>	1.5m
<b>MINIMUM REAR YARD SETBACK</b>	2.5m
<b>MAXIMUM BUILDING HEIGHT</b>	12m
<b>MAXIMUM FLOOR SPACE INDEX</b>	2
<b>MAXIMUM FLOOR SPACE INDEX</b>	2
<b>LANDSCAPED AREA</b>	15% of GFA
<b>PERCENTAGE OF GFA</b>	17% of GFA
<b>PERCENTAGE OF GFA</b>	42% of lot area
<b>PERCENTAGE OF GFA</b>	86% of lot area

SITE 2	
<b>PROPERTY DESCRIPTION</b>	PROPOSED
<b>PROPOSED BUILDING</b>	PROPOSED
<b>CITY OF OTTAWA NUMBER</b>	4120 RUSSELL RD OTTAWA, ON
<b>MUNICIPAL ADDRESS</b>	4120 RUSSELL RD OTTAWA, ON
<b>SITE INFORMATION</b>	
<b>LOT NUMBER</b>	1419 m <sup>2</sup>
<b>LOT AREA</b>	1419 m <sup>2</sup>
<b>LOT DEPTH</b>	30 m
<b>BUILDING INFORMATION</b>	
<b>BUILDING AREA</b>	1749 m <sup>2</sup>
<b>BUILDING FLOOR AREA (GFA)</b>	1749 m <sup>2</sup>
<b>PROPOSED USE</b>	LIHTI INDUSTRIAL BUILDING
<b>ZONING TABLE</b>	
<b>No. of stories</b>	2
<b>MINIMUM LOT AREA</b>	4000 m <sup>2</sup>
<b>MINIMUM LOT WIDTH</b>	No minimum
<b>FRONT YARD SETBACK</b>	7.5m
<b>MINIMUM INTERIOR CLEARANCE</b>	2.5m
<b>MINIMUM SIDE YARD SETBACK</b>	1.5m
<b>MINIMUM REAR YARD SETBACK</b>	2.5m
<b>MAXIMUM BUILDING HEIGHT</b>	12m
<b>MAXIMUM FLOOR SPACE INDEX</b>	2
<b>MAXIMUM FLOOR SPACE INDEX</b>	2
<b>LANDSCAPED AREA</b>	15% of GFA
<b>PERCENTAGE OF GFA</b>	124% of GFA
<b>PERCENTAGE OF GFA</b>	56% of lot area
<b>PERCENTAGE OF GFA</b>	196% of lot area

SITE 3	
<b>PROPERTY DESCRIPTION</b>	PROPOSED
<b>PROPOSED BUILDING</b>	PROPOSED
<b>CITY OF OTTAWA NUMBER</b>	4655 RUSSELL RD OTTAWA, ON
<b>MUNICIPAL ADDRESS</b>	4655 RUSSELL RD OTTAWA, ON
<b>SITE INFORMATION</b>	
<b>LOT NUMBER</b>	836 m <sup>2</sup>
<b>LOT AREA</b>	836 m <sup>2</sup>
<b>LOT DEPTH</b>	137 m
<b>BUILDING INFORMATION</b>	
<b>BUILDING AREA</b>	73 568 m <sup>2</sup>
<b>BUILDING FLOOR AREA (GFA)</b>	73 568 m <sup>2</sup>
<b>PROPOSED USE</b>	LIHTI INDUSTRIAL BUILDING
<b>ZONING TABLE</b>	
<b>No. of stories</b>	2
<b>MINIMUM LOT AREA</b>	4000 m <sup>2</sup>
<b>MINIMUM LOT WIDTH</b>	No minimum
<b>FRONT YARD SETBACK</b>	7.5m
<b>MINIMUM INTERIOR CLEARANCE</b>	2.5m
<b>MINIMUM SIDE YARD SETBACK</b>	1.5m
<b>MINIMUM REAR YARD SETBACK</b>	2.5m
<b>MAXIMUM BUILDING HEIGHT</b>	12m
<b>MAXIMUM FLOOR SPACE INDEX</b>	2
<b>MAXIMUM FLOOR SPACE INDEX</b>	2
<b>LANDSCAPED AREA</b>	15% of GFA
<b>PERCENTAGE OF GFA</b>	100% of GFA
<b>PERCENTAGE OF GFA</b>	48% of lot area
<b>PERCENTAGE OF GFA</b>	74% of lot area

01 SITE PLAN  
 A101

**AVENUE 31**

**PROJET | PAYSAGE**

**Figur.r**

**NATIONAL CAPITAL BUSINESS PARK**

2020-03-04

# APPENDIX D

## Crozier 2022 TIA Excerpts

**TRANSPORTATION IMPACT ASSESSMENT**

**NATIONAL CAPITAL BUSINESS PARK "SITE 3"  
PROPOSED INDUSTRIAL DEVELOPMENT  
4055 RUSSELL ROAD  
CITY OF OTTAWA**

**PREPARED FOR:  
AVENUE 31 CAPITAL INC.**

**PREPARED BY:  
C.F. CROZIER & ASSOCIATES INC.  
2800 HIGH POINT DRIVE, SUITE 100  
MILTON, ON L9T 6P4**

**JANUARY 2022**

**CFCA FILE NO. 1909-5877**

The material in this report reflects best judgment in light of the information available at the time of preparation. Any use which a third party makes of this report, or any reliance on or decisions made based on it, are the responsibilities of such third parties. C.F. Crozier & Associates Inc. accepts no responsibility for damages, if any, suffered by any third party as a result of decisions made or actions based on this report.



### 1.3 Development Proposal

Based on the conceptual site plan prepared by Ware Malcomb (dated May 7, 2021) as used in the first TIA submission, the proposed development includes three industrial buildings (with offices) as listed below:

- Industrial Building A1 has a total Gross Floor Area (GFA) of 59,425 m<sup>2</sup>, with 2,412 m<sup>2</sup> GFA being office space. A total of 140 trailer parking spaces, 265 surface level car parking spaces and associated loading docks are proposed.
- Industrial Building A2 has a total of 11,718 m<sup>2</sup> GFA, of which 786 m<sup>2</sup> GFA is office. A total of 125 surface level car parking spaces and associated loading docks are proposed.
- Industrial Building B has a total of 15,657 m<sup>2</sup> GFA, of which 1,289 m<sup>2</sup> GFA is office. A total of 166 surface level car parking spaces and associated loading docks are proposed.
- Two full moves site access connections to Russel Road. One is expected to serve the entire development and the other mainly serves the trailer trucks at Building A1.

It is noted that a most recent site plan (dated May 13, 2021) included minor changes to the building GFA's as listed below:

- Building A1: total of 59,323 m<sup>2</sup> Gross Floor Area (GFA)
- Building A2: total of 12,141 m<sup>2</sup> GFA
- Building B: total of 15,500.5 m<sup>2</sup> GFA

As presented above the current site plan results in a total industrial GFA of 86,965 m<sup>2</sup>, thus, 165 more compared to the original site plan used in the first submission TIA. Given the immaterial nature of the site plan change, the original analysis is maintained in this TIA.

Similar to the remaining National Capital Business Park developments, the proposed development has an anticipated build out by 2023. Refer to **Appendix B** for the conceptual site plan.

## 2.0 Screening

The City's TIA Guidelines contain a screening form highlighting the criteria based on which a TIA is required for a proposed development. There are three triggers, which includes the trip generation, location, and safety. A TIA study is required if at least one of the triggers is satisfied.

**Trip Generation Trigger** – the proposed industrial development has a total GFA that exceeds 5,000 m<sup>2</sup> and is anticipated to generate over 60 person trips/peak hour. Therefore, this trigger is satisfied.

**Location Triggers** – The site proposes main access connections to Russell Road which is not part of the City's Transit Priority, Rapid Transit or Spine Bicycle Networks. Additionally, the subject property is not located in a Design Priority Area (DPA) or Transit-Oriented Development (TOD) zone. Therefore, this trigger is not satisfied.

**Safety Triggers** – This trigger is satisfied as the development proposes new connections onto Russell Road, which has a posted speed limit of 80 km/h.

## 4.0 Forecasting

The proposed development will result in new traffic turning movements on the boundary road network that would otherwise not exist. This section presents the generated trips and trip assignment through the study intersections. The forecasting and trip assignment methodology conforms to modules 3.1 and 3.2 of the TIA Guidelines.

### 4.1 Auto Trip Generation

Trip generation for the proposed development was forecasted using the Institute of Transportation Engineers (ITE) Trip Generation Manual, 10<sup>th</sup> Edition.

Though the master TIA study used LUC 156 "High-Cube Parcel Hub Warehouse" for building A1, the proponent has noted that the use of the subject building is expected to be a typical industrial warehouse similar to the other two buildings (A2 and B). Therefore, the trip generation rates for Land Use Category (LUC) 150 "Warehousing" were applied to the proposed buildings A1, A2 and B to generate both the total auto trips and truck trips.

Conservatively, the greater trip generation between the fitted curve equation and average rate methodologies were used. **Table 6** outlines the total auto trip and truck trip generation for the proposed development.

**Table 6: Site Auto-Trip Generation**

Building	ITE Land Use Category	Gross Floor Area (GFA)	Peak Hour	Number of Trips		
				Inbound	Outbound	Total
Total Auto Trip Generation						
All three Buildings (A1, A2 and B)	LUC 150: Warehousing	86,800 m <sup>2</sup> (934,307 ft <sup>2</sup> )	A.M.	122	37	159
			P.M.	48	130	178
Truck Trip Generation						
All three Buildings (A1, A2 and B)	LUC 150: Warehousing	86,800 m <sup>2</sup> (934,307 ft <sup>2</sup> )	A.M.	10	9	19
			P.M.	15	13	28
Total Trips			A.M.	119	42	141
			P.M.	58	129	159

Given the assumption of LUC 156 "High-Cube Parcel Hub Warehouse" for building A1 in the master TIA, their trip generation forecast was overestimated as presented in **Table 7**.

**Table 7: Site Auto-Trip Generation per Master TIA**

Travel Mode	ITE Land Use Category	Gross Floor Area (GFA)	Peak Hour	Number of Trips		
				Inbound	Outbound	Total
Total Auto Trip Generation						
Site 3 (per master TIA)	LUC 150: Warehousing	11,167 m <sup>2</sup> (120,200 ft <sup>2</sup> )	A.M.	30	9	39
			P.M.	12	30	42
	LUC 156: High-Cube Parcel Hub Warehouse	64,521 m <sup>2</sup> (694,500 ft <sup>2</sup> )	A.M.	367	366	733
			P.M.	493	232	725
Total Trips			A.M.	397	375	772
			P.M.	505	262	767

Comparing **Tables 6 and 7**, the current proposal for the site results in a lower trip generation and is expected to have a lesser overall impact to the boundary road network than captured in the master TIA. Section 5 further discusses traffic operations at boundary study intersections.

#### 4.2 Person Trips and Modal Shares

The City's TIA Guidelines provide methodology for forecasting person trips using the ITE auto trip generation, as follows:

- Assume a 10% non-auto mode share for trips generated by the proposed development for low-density areas with low transit mode shares.
- Assume an average vehicle occupancy of 1.15 for the purposes of translating auto trips to person trips.

The methodology outlined above equates to a factor of 1.28 to be applied to the ITE auto trip rates outlined in **Table 6** to forecast the person trips presented in **Table 8**. **Table 8** further outlines the modal splits of the person trips based on the target modal shares identified in section 5.1 of the master TIA study. The master TIA study notes that the modal split for the National Capital Business Park developments is expected to be consistent with the existing modal shares of the 2011 TRANS O-D Survey Report for the Hunt Club district. However, target modal split for the site's surrounding area were determined by adjusting the existing modal splits (10% increase of auto driver split) to account for the site being located in an area with comparatively less dense active transportation connections and transit service.

**Table 8: Person Trips by Travel Mode**

Travel Mode	Modal Share		A.M. Peak Hour Trips			P.M. Peak Hour Trips		
	Existing	Target	In	Out	Total	In	Out	Total
	Person Trips		156	47	203	61	166	227
Auto Driver	60%	70%	109	33	142	43	116	159
Auto Passenger	15%	15%	23	7	30	9	25	34
Transit	15%	10%	16	5	20	6	17	23
Active Transport	10%	5%	8	2	10	3	8	11

The full build-out of the proposed development is expected to generate a total of 161 and 187 two-way auto trips during the weekday a.m. and p.m. peak hours, respectively, which includes the 19 and 28 two-way truck trips (Table 6) during the weekday a.m. and p.m. peak hour, respectively. Given that the proposed development is solely industrial use, no material trips due to pass-by or synergy between the buildings is expected. Therefore, no internal trip synergy reductions or pass-by trip reductions were applied.

### 4.3 Trip Distribution and Assignment

The development generated trips were distributed based on the existing travel and settlement patterns similar to section 5.1 of the master TIA study. The general distributions are noted below.

- 10% To/from the north via Russell Road (Alta Vista)
- 10% to/from the south / east (Russell Road south, Hwy 417 E)
- 5% to/from the south (East Barrhaven and Airport via Ramsayville Road)
- 40% to/from the north/west (Hwy 417 W)
- 15% to/from the west via Walkley Road (Alta Vista, Baseline Road)
- 20% to/from the west via Hunt Club (Nepean)

Further, similar to the master TIA study a single distribution pattern was assumed for the employee (passenger car) trips and truck trips as the truck trips make a small portion of the total trips and patterns are not expected to differ significantly given the location of the development.

Given the layout of the site and the proposed site accesses at Russell Road, all employee trips were assigned to the east access. It is expected that during the peak hours, a greater portion of truck trips will use the less busy west site access, as such 70% truck distribution to the west access was assumed. To account for the impact of the truck trips, a 100% heavy goods (HGV) was applied to the left and right turning movements at the west access in the synchro analysis. All other movements at all intersections assumed a 5% HGV in synchro analysis similar to the Mater TIA study.

The detailed trip distribution and trip assignment for the proposed development are presented in **Figures 3 and 4**, respectively.

## 5.0 Analysis

### 5.1 Development Design

#### 5.1.1. Design for Sustainable Modes

The site proposes pedestrian sidewalks connecting all three buildings to the internal road within the site (identified as east Site Access). Further, the internal road will have sidewalks connecting ultimately to Russell Road. Refer to **Appendix C** for the multi-modal site circulation plan.

All the buildings on the site are within a 500 m walking distance of the existing OC Transpo bus stop on Russell Road, located at the approximate intersection of the east site access and Russell Road. Buildings A1 and B which generates approximately 96% of the site's person trips are within 400 m (five minutes) of the bus stop, consistent with the TIA Guidelines.

The site satisfies the required measures per the Transportation Demand Management (TDM) – Supportive Development Design and infrastructure Checklist. The TDM checklist is included in **Appendix C**.

#### 5.1.2. Circulation and Access

The internal roadway is wide and has adequate radii to support the expected WB-20 and potential long combination trucks expected at the site as illustrated on the truck turning diagrams in **Appendix I**. Circulation of the site for other vehicles such as the waste removal trucks, fire truck and employee vehicles are expected to be feasible given they are smaller than the design trucks.

### 5.2 Boundary Road Network

Russell Road is the only boundary street to the proposed "Site 3" development. As noted under section 3, the roadway is a truck route (permitting full loads) with a posted speed limit of 80km/h, has a gravel shoulder on both sides and no pedestrian or bicycle facilities.

**Table 8** highlights the existing MMLOS and the target minimum desirable MMLOS based on the City of Ottawa TIA supplement - MMLOS Guidelines. As the site is in an Urban Employment Area, the target MMLOS are based on an arterial road located within an employment area per Exhibit 22 of the MMLOS guidelines (see **Appendix C** herein).

**Table 9: MMLOS Summary**

Roadway	Horizon	PLOS	BLOS	TkLOS
Russell Road	Existing	F	F	C
	Target	C	E	B

As presented in **Table 9**, the pedestrian level of service (PLOS), bicycle LOS (BLOS) and truck LOS (TkLOS) along the boundary Russell Road are short of the minimum desired. In order to improve the existing MMLOS to the desired, the following road improvements may be considered by the City.

**Table 18: Zoning By-Law Parking Requirements**

Land Use	Gross Floor Area (GFA)	By-Law Parking Rate	Parking Required	Total Parking Required	Parking Supply
Warehouse	82,313 m <sup>2</sup>	0.8 per 100 m <sup>2</sup> for the first 5000 m <sup>2</sup> GFA 0.4 per 100 m <sup>2</sup> for above 5000 m <sup>2</sup> GFA	350 spaces	458 parking spaces	556 parking spaces
Office	4,487 m <sup>2</sup>	2.4 per 100 m <sup>2</sup> of GFA	108 spaces		

The vehicle parking supply of 556 spaces results in a surplus of 98 spaces compared to the City's Zoning By-Law requirement for the site. Additionally, the site provides the required barrier free accessible parking spaces and bicycle parking spaces for each building. Excess loading spaces are provided for each building compared to the By-law requirements.

### 5.8 Transportation Demand Management

To support sustainable transportation, the TDM measures listed below are recommended for the site based on the City's TDM checklist. The TDM checklist is included in **Appendix C**.

- Provision of pedestrian sidewalks connecting the buildings and the parking areas as well as to the intersection on Russel Road where a transit stop is anticipated.
- Provision of bicycle and vehicle parking spaces in conformance with the zoning by-law requirements.
- Display local area maps with walking/cycling access routes and key destinations at main entrances or lobbies.
- Display relevant transit schedules and route maps at entrances.

Given the conveniently close proximity of transit, as well as the proposed TDM measures for this development, employees and visitors will be encouraged to be less dependent on single occupant auto trips.

## 6.0 Conclusions and Recommendations

This Transportation Impact Assessment (TIA) has assessed the transportation impacts of the proposed National Capital Business Park "Site 3" industrial development at the 4055 Russell Road site in the City of Ottawa. The analysis contained within this report has resulted in the following key findings:

- Under 2021 existing traffic conditions, the study intersections are projected to operate at the Level of Services (LOS) below.
  - Hawthorne Road and Russell Road is forecast to operate below capacity at a LOS "B" or better during the a.m. and p.m. peak hours.
  - Hawthorne Road and Hunt Club Road is projected to operate at a LOS "D" and "E" during the a.m. and p.m. peak hours, respectively.
  - The stop-controlled southbound left turn movement on the Highway 417 Offramp at Hunt Club Road is forecast to operate at a LOS "D" during the a.m. and p.m. peak hours.

- The proposed industrial development is projected to generate a total of 644 and 638 two-way auto trips during the weekday a.m. and p.m. peak hours, respectively, which includes 64 and 47 two-way truck trips during the weekday a.m. and p.m. peak hours, respectively.
- Under the 2023 and 2028 future background conditions:
  - Hawthorne Road and Russell Road is forecast to operate below capacity at a LOS "B" or better during the a.m. and p.m. peak hours.
  - Hawthorne Road and Hunt Club Road is projected to operate at a LOS "D" and "E" during the a.m. and p.m. peak hours, respectively.
  - At Hawthorne Road and Hunt Club Road, the northbound through, eastbound and westbound left turn movements are forecast to exceed capacity during the peak hours.
  - The future signalized intersection of Last Mile Drive at Hunt Club Road is forecast to operate at a LOS "A" during the a.m. and p.m. peak hours.
  - The future stop-controlled Last Mile Drive connection to Russell Road is projected to operate at a LOS "C" or better.
  - The stop-controlled southbound left turn (SBL) movement at the intersection of Hunt Club Road and Highway 417 Offramp is forecast to operate at a LOS "E" and "D" or better during the a.m. and p.m. peak hours, respectively. This includes a 2033 horizon.
- For the 2023 and 2028 total traffic conditions (includes site generated trips), the study intersections are projected to operate as follows:
  - Hawthorne Road and Russell Road is forecast to operate at a LOS "B" or better during the a.m. and p.m. peak hours.
  - Hawthorne Road and Hunt Club Road is projected to operate at a LOS "E" during the a.m. and p.m. peak hours.
  - Similar to the future background, the eastbound and westbound left turns as well as the northbound through movements are forecast to exceed capacity during either of the a.m. or p.m. peak hours.
  - The future signalized intersection of Last Mile Drive at Hunt Club Road is forecast to operate at a LOS "A" during the a.m. and p.m. peak hours.
  - The future stop-controlled Last Mile Drive connection to Russell Road is projected to operate at a LOS "C" or better.
  - Including 2033 total traffic conditions, the stop-controlled southbound left turn (SBL) movement of the Highway 417 Offramp at the intersection with Hunt Club Road is forecast to operate at a LOS "E" and "D" or better during the a.m. and p.m. peak hours, respectively.

- The proposed stop-controlled full-moves east site access at Russell Road is projected to operate at a LOS "C" or better.
  - The proposed stop-controlled full-moves west site access at Russell Road is projected to operate at a LOS "B" or better.
- The proposed site accesses are projected to operate efficiently and safely without any issues related to sight-lines, corner clearance, access conflicts, truck movements and transit operational conflicts. No external road improvements or turn lanes are warranted at the site accesses to support the development.
- The vehicle parking supply of 556 spaces satisfies the City's Zoning By-Law requirement for the site. Additionally, the site provides the required barrier free accessible parking spaces and bicycle parking spaces for each building. Excess loading spaces are provided for each building compared to the By-law requirements.
- To support sustainable transportation, the site proposes TDM measures such as provision of pedestrian sidewalks, bicycle parking, display of local transit and active transport maps at main entrances. These TDM measures are expected to encourage employees and visitors to be less dependent on single occupant auto trips.
- It is recommended that the City consider the following:
  - Future optimization of the a.m. signal time may be needed at the Hawthorne Road and Russell Road intersection to provide additional capacity for the westbound right (WBR) turn during the a.m. peak hour.
  - As the eastbound and westbound left turn volumes exceeds capacity, consideration should be given to optimization of the signal timing plans to increase the effective green time for these left turns. Further, these movements have peak hour volumes in excess of 300, a threshold identified to warrant dual left turn lanes per the Transportation Association of Canada (TAC) Geometric Design Guide for Canadian Roads (GDGCR). Therefore, dual eastbound and westbound left turn lanes may be investigated in future as a long term measure to further improve the intersection operations.
  - The northbound through (NBT) movement at Hunt Club Road and Hawthorne Road is forecast to operate above capacity under the study horizons. Given the NBT peak hour volumes are less than 500 under all study horizons, signal time optimization to increase the effective green time for the NBT is expected to provide the additional capacity.
  - Given the existing and anticipated developments on both sides of Russel Road between Hawthorne Road and Hunt Club Road, it is recommended that the City consider reducing the posted speed limit from 80 km/h to 60 km/h for the subject roadway segment as part of implementation of the National Capital Business Park developments.
  - Considering the potential long term impact of the Covid-19 pandemic on home-work trips, the forecasted future volumes may be overstated, it is important to monitor

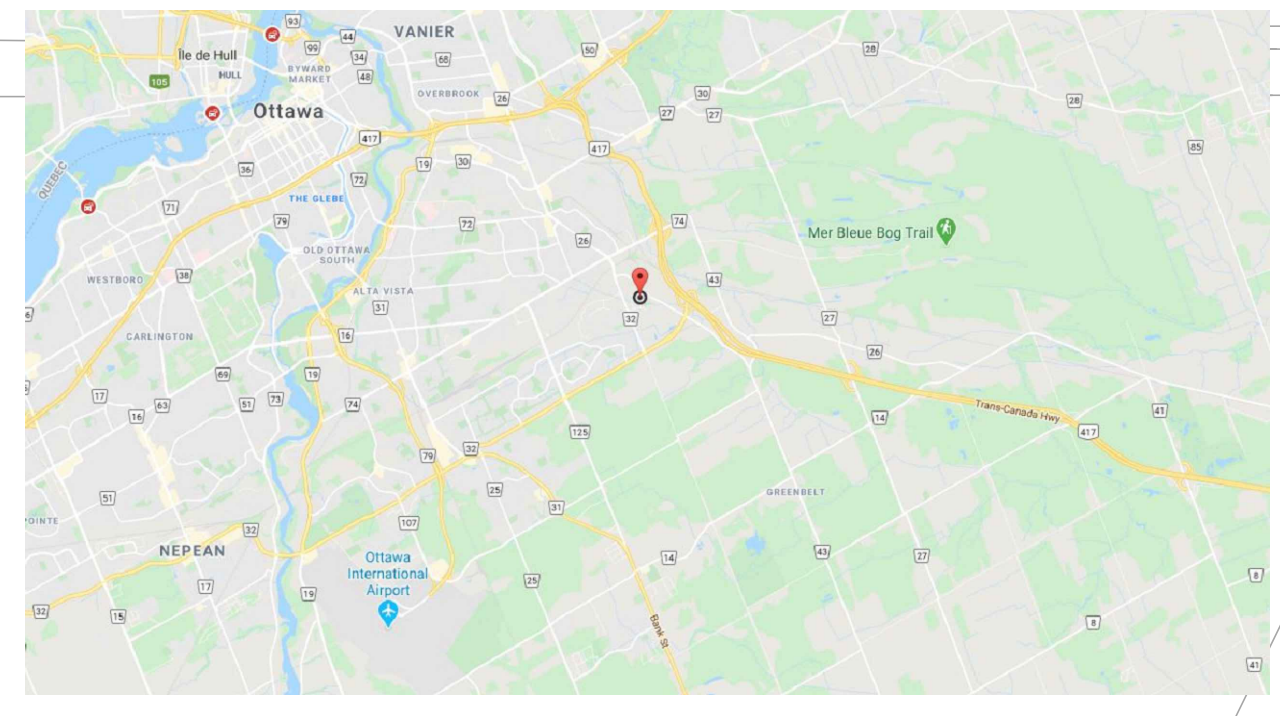

TRANS CANADA HWY.

THE KING'S HIGHWAY

RUSSELL RD.

RUSSELL RD.

**BLDG A2**  
 FOOTPRINT: 12,140.94 SM  
 (130,684 SF)  
 CLR. HGT: 9.75m (32')

SNOW STORAGE 105.0 m<sup>2</sup>

**BLDG B**  
 FOOTPRINT: 3,300.5 SM  
 CLR. HGT: 9.15m (29')

SNOW STORAGE 105.0 m<sup>2</sup>

**BLDG A1**  
 FOOTPRINT: 59,323.1 SM (638,550 SF)  
 CLR. HGT: 10.97m (36'-0")

TENANT 1 14,865.9 SM 160,015 SF	TENANT 2 14,759.7 SM 159,260 SF	TENANT 3 14,759.7 SM 159,260 SF	TENANT 4 14,940.2 SM 160,815 SF
---------------------------------------	---------------------------------------	---------------------------------------	---------------------------------------

SNOW STORAGE 660.0 m<sup>2</sup>

SNOW STORAGE 360.0 m<sup>2</sup>

**WARE MALCOMB**  
 Leading Design for Commercial Real Estate

architecture 180 base pro mills drive, unit 103  
 planning vaughan, ontario L4K 5W9  
 interiors p.905.760.1221  
 graphics f.905.248.3344  
 civil engineering a business name of WMA Inc.

**NATIONAL CAPITAL  
 BUILDING A2  
 RUSSELL RD  
 OTTAWA, ONTARIO**

OVERALL SITE PLAN

DATE	ISSUED FOR	REMARKS
1	2021-05-13	ISSUED FOR SPA

PA / PM: AS/LN  
 DRAWN BY: HW  
 JOB NO.: TOR21-0007-00

SHEET  
**A1.0**

THESE DRAWINGS AND SPECIFICATIONS ARE THE PROPERTY AND COPYRIGHT OF WARE MALCOMB AND SHALL NOT BE USED ON ANY OTHER WORK EXCEPT BY AGREEMENT WITH WARE MALCOMB. WRITTEN DIMENSIONS SHALL TAKE PRECEDENCE OVER SCALED DIMENSIONS AND SHALL BE VERIFIED ON THE JOB SITE. ANY DISCREPANCY SHALL BE BROUGHT TO THE NOTICE OF WARE MALCOMB PRIOR TO THE COMMENCEMENT OF ANY WORK.

SITE STATISTICS

ZONING	IH/AG	
GROSS SITE AREA	240,980.00m <sup>2</sup>	
Zone Permitted Use (OTTAWA ZONING BY-LAW NO. 2008-250)		
Proposed Use	Industrial	
Regulations (Part 11: Industrial Zones)		
	Proposed	Required
Industrial BLDG A1		
Min. Front Yard Building Setback (m)	21.80	7.5 m
Min. Interior Side Yard Building Set back (m)	29.80	7.5 m
Min.Rear Yard Building Setback (m)	15.40	7.5 m
Industrial BLDG A2		
Min. Front Yard Building Setback (m)	7.5 m	7.5 m
Min. Interior Side Yard Building Set back (m)	41.9 m	7.5 m
Min.Rear Yard Building Setback (m)	7.5 m	7.5 m
Industrial BLDG B		
Min. Front Yard Building Setback (m)	44.4 m	7.5 m
Min. Interior Side Yard Building Set back (m)	12.2 m	7.5 m
Min.Rear Yard Building Setback (m)	30.9 m	7.5 m
Min.Landscape Front Yard Setback (m)	30.59 m	3 m
Max. Floor Space Index	0.4	2
Max. Building Height	11.25 m	22 m
BUILDING FLOOR AREA		
Industrial BLDG A1		
Industrial Area	57,013.00m <sup>2</sup>	
Office Area	2,412.00m <sup>2</sup>	
<b>TOTAL BUILDING GFA</b>	<b>59,425.00m<sup>2</sup></b>	
Industrial BLDG A2		
Industrial Area	10,932.00m <sup>2</sup>	
Office Area	786.00m <sup>2</sup>	
<b>TOTAL BUILDING GFA</b>	<b>11,718.00m<sup>2</sup></b>	
Industrial BLDG B		
Industrial Area	14,368.00m <sup>2</sup>	
Office Area	1,289.00m <sup>2</sup>	
<b>TOTAL BUILDING GFA</b>	<b>15,657.00m<sup>2</sup></b>	
PARKING REQUIREMENT		
	REQUIRED	PROPOSED
Industrial BLDG A1		
GFA @ 0.8 Spaces Per 100m <sup>2</sup> up to 5,000 m <sup>2</sup> , 0.4 Spaces Per 100m <sup>2</sup> above 5,000 m <sup>2</sup>	258	
<b>Total No. of Parking Spaces</b>	<b>258</b>	<b>265</b>
Barrier Free Parking Spaces	8	8
Industrial BLDG A2		
GFA @ 0.8 Spaces Per 100m <sup>2</sup> up to 5,000 m <sup>2</sup> , 0.4 Spaces Per 100m <sup>2</sup> above 5,000 m <sup>2</sup>	67	
<b>Total No. of Parking Spaces</b>	<b>67</b>	<b>125</b>
Barrier Free Parking Spaces	3	4
Industrial BLDG B		
GFA @ 0.8 Spaces Per 100m <sup>2</sup> up to 5,000 m <sup>2</sup> , 0.4 Spaces Per 100m <sup>2</sup> above 5,000 m <sup>2</sup>	77	
<b>Total No. of Parking Spaces</b>	<b>77</b>	<b>166</b>
Barrier Free Parking Spaces	4	4
Parking Stall Dimensions	2.6 m X 5.2 m	
Barrier Free Parking Stall Type A	3.4m X 5.2m	
Barrier Free Parking Stall Type B	2.4m X 5.2m	
Bicycle Parking Space Dimensions	1.8m X 0.6m	
No. Of Bicycle Parking (Warehouse: 1 per 2000m <sup>2</sup> , Office 1 per 250m <sup>2</sup> )		
Industrial BLDG A1	36	36
Industrial BLDG A2	9	9
Industrial BLDG B	10	10
Loading Space Dimensions	3.5m X 9.0m	
No. Of Loading Spaces		
Industrial BLDG A1	3	112
Industrial BLDG A2	2	36
Industrial BLDG B	2	44
Trailer Parking (A1 only)	140	
DOCK DOOR STATISTICS (PROPOSED)		
	DOCK-HIGH	OVERHEAD
Industrial BLDG A1	112	8
Industrial BLDG A2	36	2
Industrial BLDG B	44	2

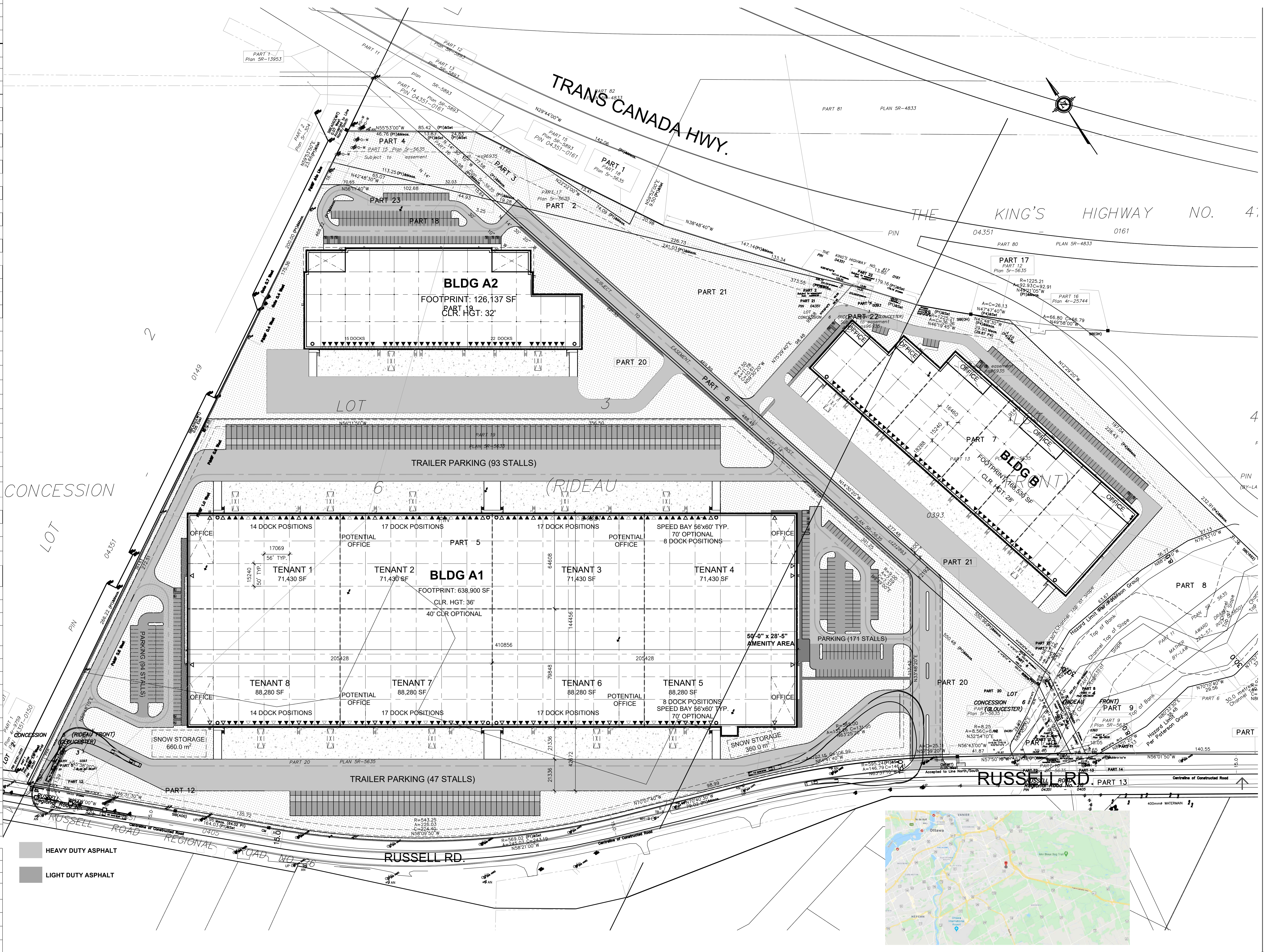

HEAVY DUTY ASPHALT  
LIGHT DUTY ASPHALT

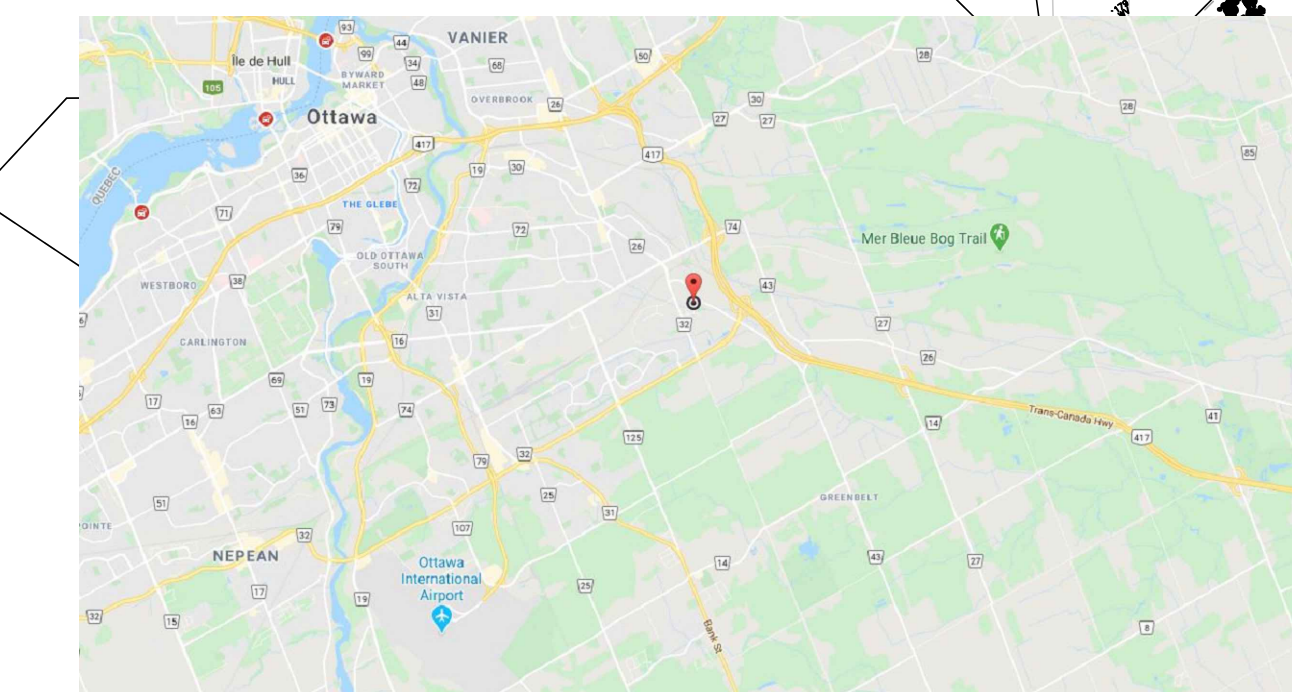

This conceptual design is based upon a preliminary review of entitlement requirements and on unverified and possibly incomplete site and/or building information, and is intended merely to assist in exploring how the project might be developed.

1:1000

0 25m 50m 100m

NORTH

Conceptual Site Plan

MASTERPLAN

National Capital Business Park / Park d'Affaires de la Capitale Nationale, Russell Road & Hunt Club Road, Ottawa, ON CAN

WARE MALCOMB

TOR20-0028-00  
2021-05-07

SHEET  
4



# APPENDIX E

## TIA Screening Form

**City of Ottawa 2017 TIA Guidelines Screening Form**

**1. Description of Proposed Development**

Municipal Address	4055 Russell Road (Buildings A1&A3 National Capital Business Park)
Description of Location	The site is located in the planned National Capital Business Park
Land Use Classification	<b>Industrial Development</b>
Development Size (units)	-
Development Size (m <sup>2</sup> )	<b>44,447 m<sup>2</sup> (478,210 SF)</b>
Number of Accesses and Locations	4 Site Accesses (3 onto Logistics Private Road, one direct onto Russell Road)
Phase of Development	
Buildout Year	2030 (Assumed)

**If available, please attach a sketch of the development or site plan to this form.**

**2. Trip Generation Trigger**

Considering the Development’s Land Use type and Size (as filled out in the previous section), please refer to the Trip Generation Trigger checks below.

Land Use Type	Minimum Development Size
Single-family homes	40 units
Townhomes or apartments	90 units
Office	3,500 m <sup>2</sup>
Industrial	5,000 m <sup>2</sup>
Fast-food restaurant or coffee shop	100 m <sup>2</sup>
Destination retail	1,000 m <sup>2</sup>
Gas station or convenience market	75 m <sup>2</sup>

*\* If the development has a land use type other than what is presented in the table above, estimates of person-trip generation may be made based on average trip generation characteristics represented in the current edition of the Institute of Transportation Engineers (ITE) Trip Generation Manual.*

**If the proposed development size is greater than the sizes identified above, the Trip Generation Trigger is satisfied.**

### 3. Location Triggers

	Yes	No
Does the development propose a new driveway to a boundary street that is designated as part of the City’s Transit Priority, Rapid Transit or Spine Bicycle Networks?		✓
Is the development in a Design Priority Area (DPA) or Transit-oriented Development (TOD) zone?*		✓

\*DPA and TOD are identified in the City of Ottawa Official Plan (DPA in Section 2.5.1 and Schedules A and B; TOD in Annex 6). See Chapter 4 for a list of City of Ottawa Planning and Engineering documents that support the completion of TIA).

**If any of the above questions were answered with ‘Yes,’ the Location Trigger is satisfied.**

### 4. Safety Triggers

	Yes	No
Are posted speed limits on a boundary street are 80 km/hr or greater?	✓	
Are there any horizontal/vertical curvatures on a boundary street limits sight lines at a proposed driveway?		✓
Is the proposed driveway within the area of influence of an adjacent traffic signal or roundabout (i.e. within 300 m of intersection in rural conditions, or within 150 m of intersection in urban/ suburban conditions)?		✓
Is the proposed driveway within auxiliary lanes of an intersection?		✓
Does the proposed driveway make use of an existing median break that serves an existing site?		✓
Is there is a documented history of traffic operations or safety concerns on the boundary streets within 500 m of the development?		✓
Does the development include a drive-thru facility?		✓

**If any of the above questions were answered with ‘Yes,’ the Safety Trigger is satisfied.**

### 5. Summary

	Yes	No
Does the development satisfy the Trip Generation Trigger?	✓	
Does the development satisfy the Location Trigger?		✓
Does the development satisfy the Safety Trigger?	✓	

**If none of the triggers are satisfied, the TIA Study is complete. If one or more of the triggers is satisfied, the TIA Study must continue into the next stage (Screening and Scoping).**

# APPENDIX F

## Transit Network Information



# 47

## HAWTHORNE ST-LAURENT

### Local

**Monday to Friday / Lundi au vendredi**  
Peak periods only  
Périodes de pointe seulement

**PM**  
↑  
**ST-LAURENT**

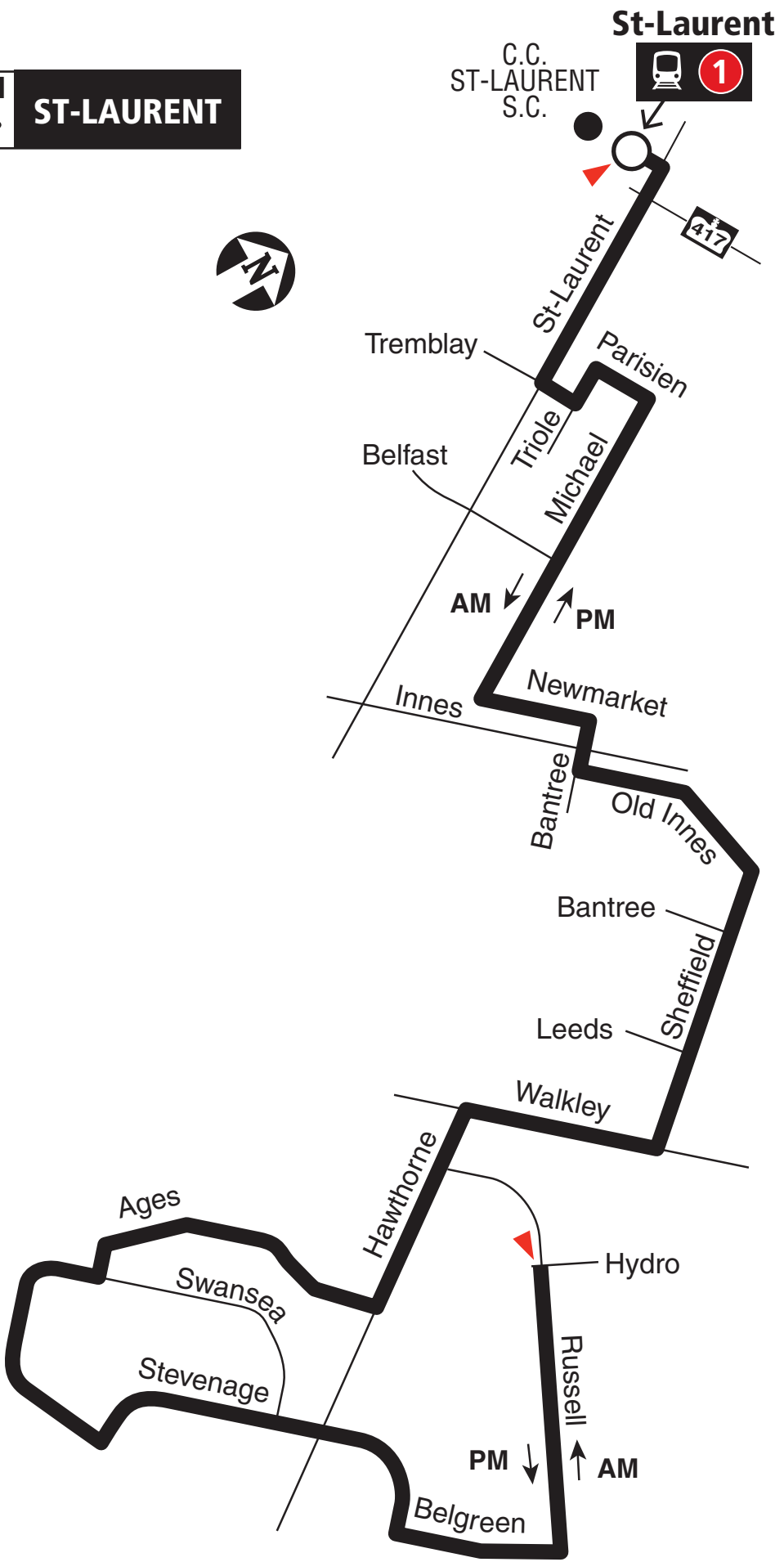

**AM**  
↓  
**HAWTHORNE**

- Station
- ▲ Timepoint / Heures de passage

2019.06

**Schedule / Horaire ..... 613-560-1000**  
**Text / Texto ..... 560560**  
*plus your four digit bus stop number / plus votre numéro d'arrêt à quatre chiffres*

Customer Service  
 Service à la clientèle ..... **613-741-4390**  
 Lost and Found / Objets perdus..... **613-563-4011**  
 Security / Sécurité ..... **613-741-2478**

**Effective June 25, 2017**  
**En vigueur 25 juin 2017**



**INFO 613-741-4390**  
**octranspo.com**

# APPENDIX G

## Ottawa Transport Mobility Plan Excerpts

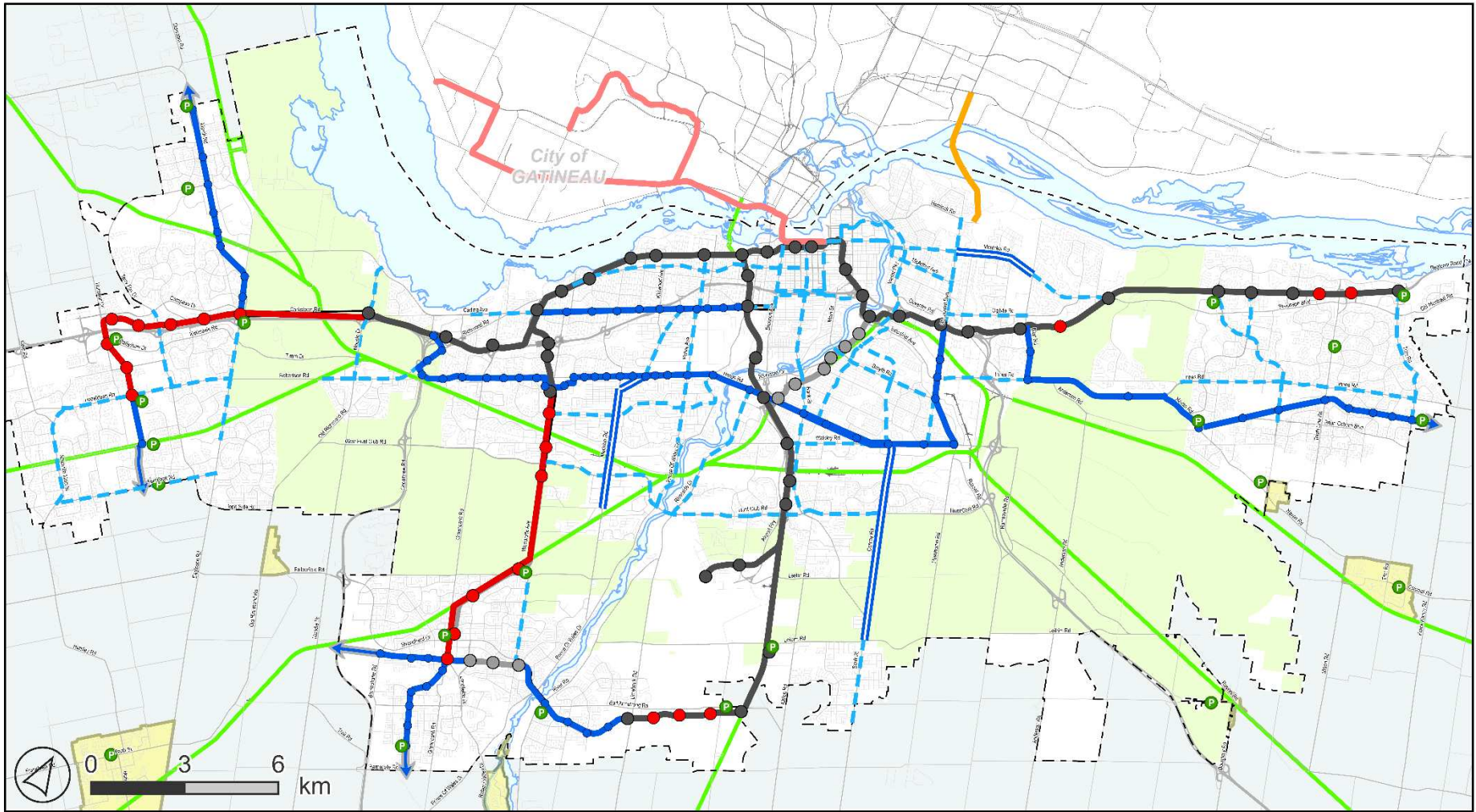

**Existing Rapid Transit**

- O-Train
- Transitway
- Existing Bus Lanes
- O-Train Station
- Transitway Station

**Transit Projects**

- O-Train
- Transitway
- Continuous Bus Lanes
- - - Transit Priority Corridor
- Gatineau Tramway (Delivered by Others)
- Future Corridor

**Transportation and Infrastructure Corridor**

- New Interprovincial Crossing (Delivered by Others)
- New O-Train Station
- New Transitway Station
- Park and Ride

**Village**

- - - Existing Urban Boundary

**Needs Based Transit Network**

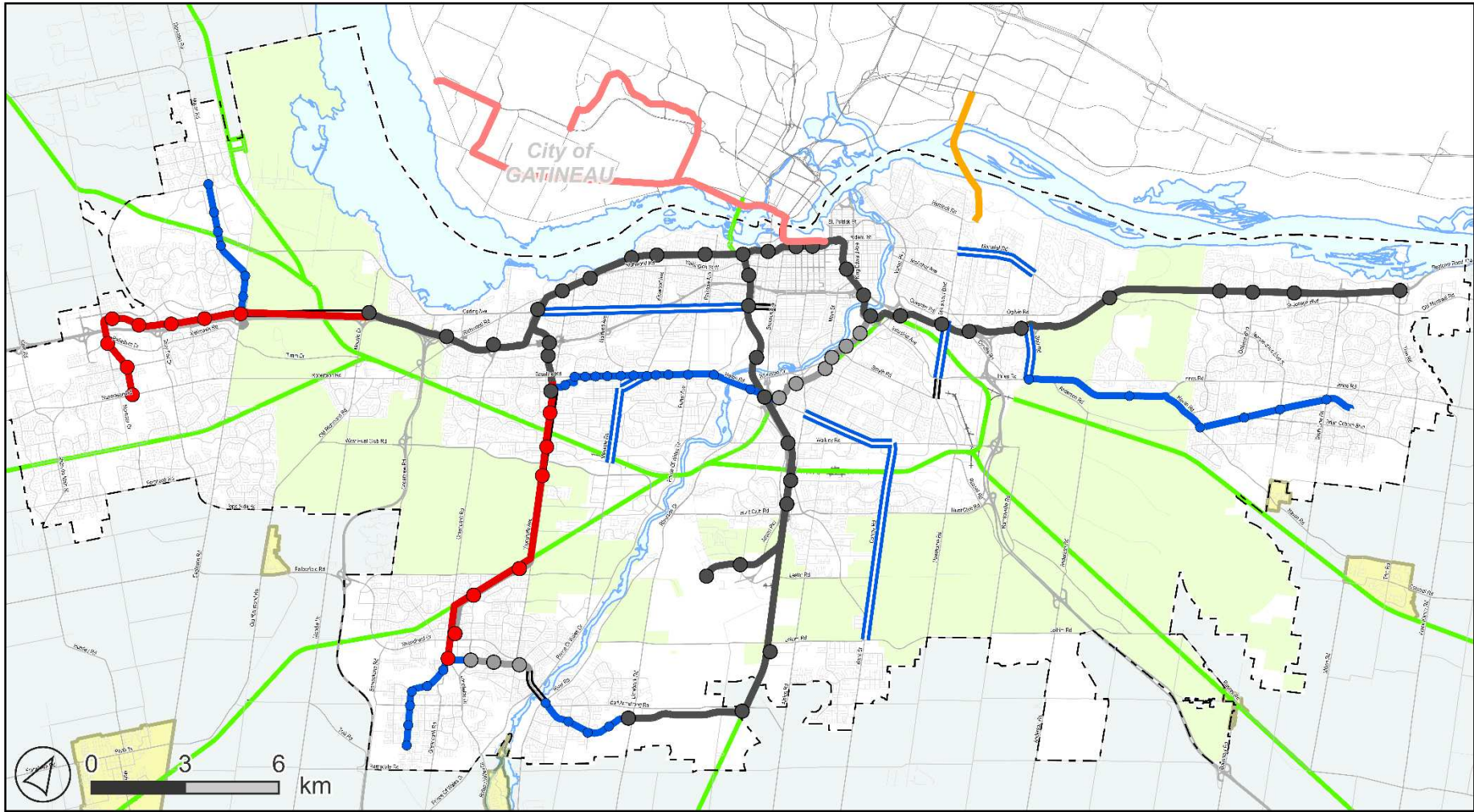

**Existing Rapid Transit**

- O-Train
- Transitway
- Existing Bus Lanes
- O-Train Station
- Transitway Station

**Transit Projects**

- O-Train
- Transitway
- Continuous Bus Lanes
- Gatineau Tramway (Delivered by Others)

- Transportation and Infrastructure Corridor
- New Interprovincial Crossing (Delivered by Others)
- New O-Train Station
- New Transitway Station

- Village Boundaries
- Existing Urban Boundary

**Priority Transit Network**

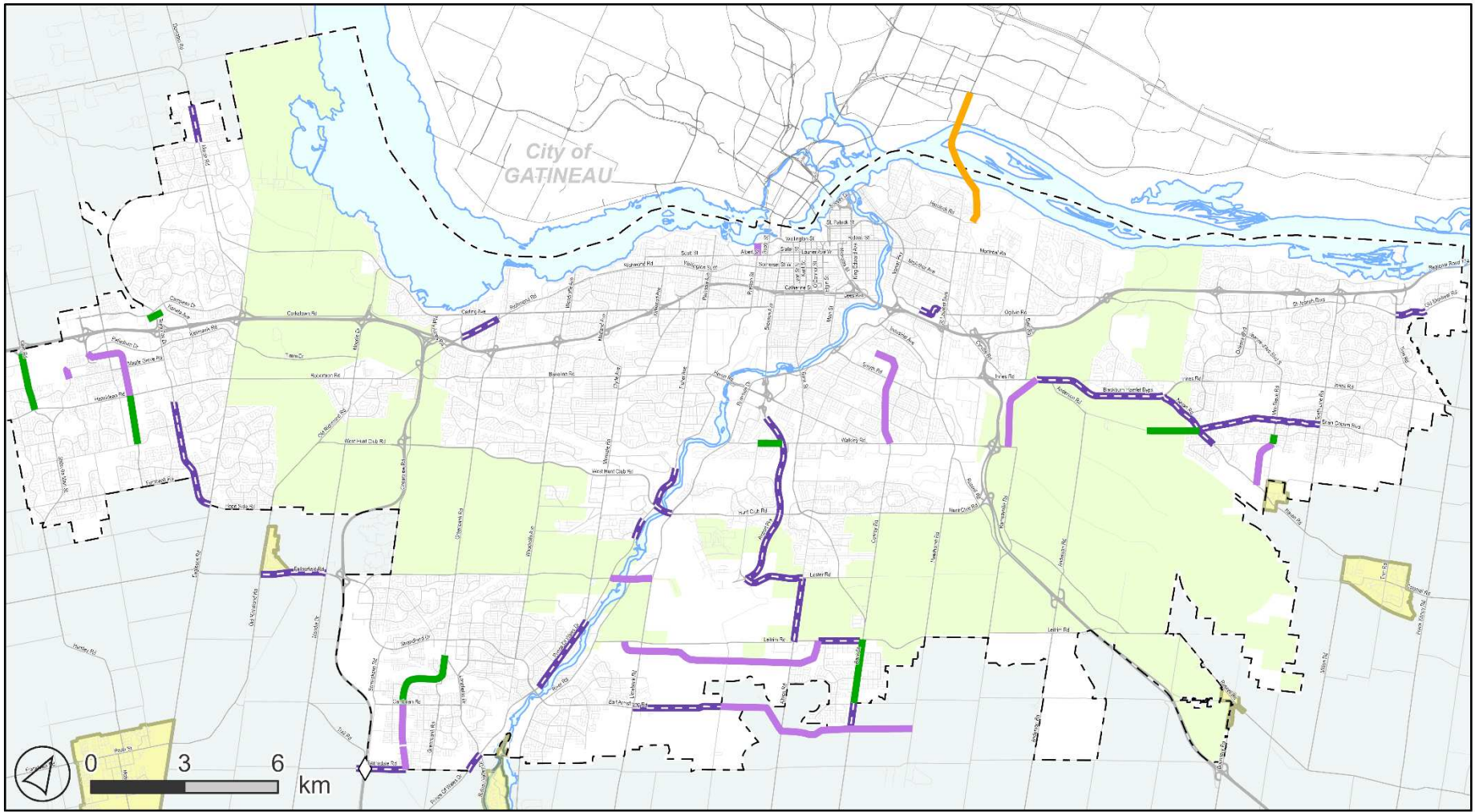

<b>Roads</b>		Village Boundaries
Road Widening	New Interchange (Delivered by Others)	Existing Urban Boundary
New Road	New Interprovincial Crossing (Delivered by Others)	
Committed Projects		

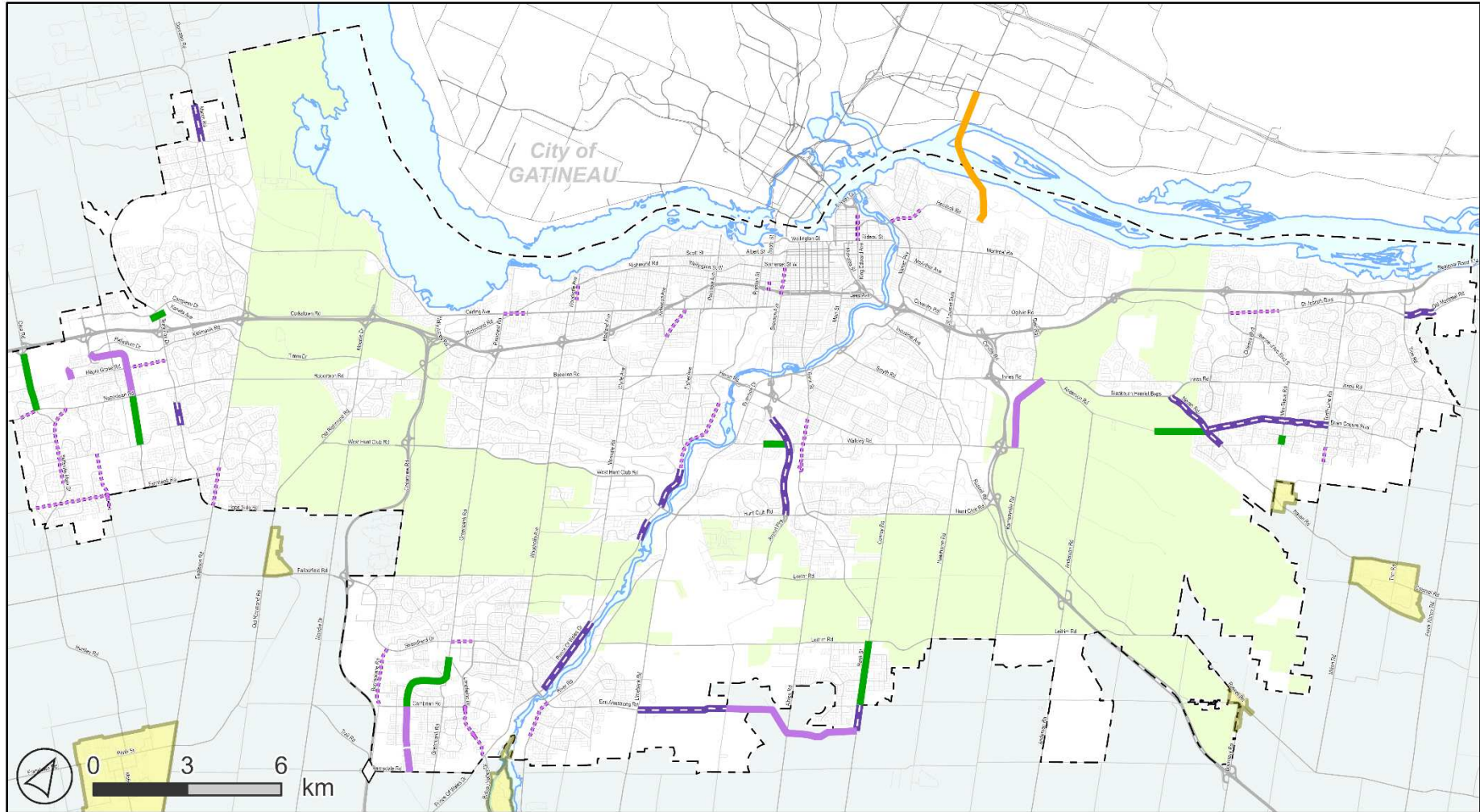

**Needs Based Road Network**



**Roads**

-  Road Widening
-  New Road
-  Committed Projects

-  New Interchange (Delivered by Others)
-  New Interprovincial Crossing (Delivered by Others)

-  Road Urbanization and Mainstreet Improvements
-  Village Boundaries
-  Existing Urban Boundary

**Priority Road Network**

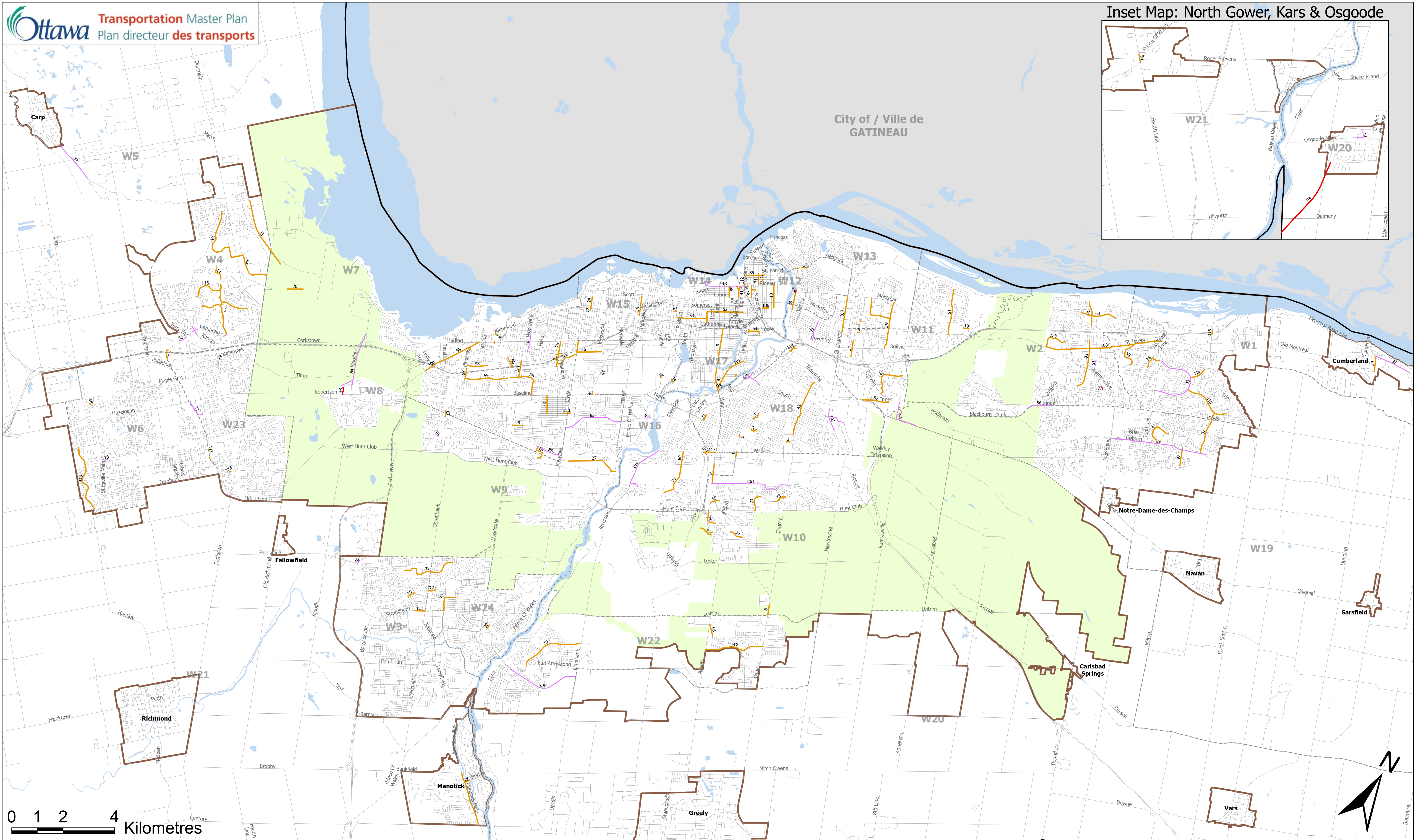

### TMP Cycling Projects Proposed Priority

- First Phase
- First Phase - Completed
- Later Phase
- Greenbelt
- Urban Area
- Wards
- Village Boundaries
- City Boundary

#	Project Name	#	Project Name	#	Project Name	#	Project Name	#	Project Name	#	Project Name
1	Albion Rd North	15	Belcourt Blvd to Frank Bender St	29	Crestview-Tanglewood Rail Crossing	44	Experimental Farm Path Connections	59	Iris St West	75	Maitland Ave Cycling
2	Alta Vista East-West Route	16	Brian Coburn Blvd	30	Crestway Dr	45	Fairlawn Ave and Woodroffe Ave	60	Jeanne d'Arc Blvd North	76	Maitland Ave Cycling Connections
3	Alta Vista North-South Route	17	Byron Ave and Churchill Ave	31	Cumberland St and Murray St East	46	Fallowfield Rd - Forager St Pathway	61	Johnston Rd	77	Malvern Dr, Foxfield Dr, and Highbury Park Dr
4	Aquaview Drive	18	Byward Market to Somerset St East	32	Cummings Ave	47	Findlay Creek Dr	62	Kanata Ave and Campeau Dr	78	Manotick Main St / Bridge St
5	Aviation Pathway Connections	19	Canotek Rd	33	Cummings Bridge Underpass	48	Fitzgerald Rd	63	Laurel St Bridge	79	McCarthy Rd and Paul Anka Dr
6	Bank St Cycling	20	Carling Ave, Beachburg Rail Underpass	34	D'Aoust Ave and Bridle Path Dr	49	Flamborough Way and Innovation Dr	64	Lees Ave to Hawthorne Ave	80	McCarthy Rd Cycling
7	Bank St Over Rail	21	Carp River Pathway	35	Dazé St	50	Fourth Line Rd	65	Legget Dr, Solandt Rd and Hines Rd	81	McClellan Rd Pathway Connectivity
8	Bank St South	22	Carp River Pathway under Hwy 417	36	Den Haag Dr and Bathgate Dr	51	Garneau Park to Carrière St	66	Leitrim Station Pathway	82	Meadowbrook Rd
9	Bank St, Lansdowne North	23	Charlemagne Blvd	37	Donald B Munro Dr and Old Carp Rd	52	Gilmour St	67	Leslie Park-Banner Rd Rail Crossing	83	Meadowlands Dr
10	Barrhaven VIA Pathway (Jockvale Rd - Antler-Dolan underpass)	24	Churchill Ave Cycling	38	Duford Dr, Prestone Dr and Tompkins Ave	53	Gladstone Ave and Percy St Cycling	68	Limebank Station Pathway	84	Moodie Dr
11	Beachburg Subdivision Rail Corridor Pathway	25	Clover St	39	Dunning Rd	54	Hartwell Locks Accessible Crossing	69	Lincoln Fields Crossings, Carling Ave and Richmond Rd	85	Murray St West
12	Beaverbrook - Kanata North Pathway	26	Clyde Ave N and Laperriere Ave	40	Echowoods Park	55	Holland Ave Cycling	70	Logan Farm Dr and Osgoode Main St	86	Nepean Creek Pathway
13	Beaverbrook Rd, Knudson Dr, Weslock Way, Walden Dr, Teron Rd, Kanata Ave and Campeau Dr	27	Colonnade Rd N	41	Elgin St Cycling	56	Innes Rd Eastbound	71	Lola St	87	Nicholas St and Daly Ave Cycling
14	Beechwood Ave	28	Cordova St and Meadowlands Dr	42	Elmvale-Canterbury Neighbourhood Bikeway	57	Innes Rd over Highway 417	72	Longfields Dr and Berrigan Dr	88	North River Rd
				43	Emerald Woods O-Train Pathway Connection	58	Inis St and Navaho Dr	73	Lorry Greenberg Dr	89	O'Connor St
								74	Main St Southbound Cycling Link	90	O-Train Crossing at Hwy 417
										91	Ogilvie Rd
										92	Old Montreal Rd
										93	Orléans Blvd
										94	Osgoode Link Pathway Extension
										95	Pinecrest Rd and Greenbank Rd
										96	Prescott-Russell Recreational Trail
										97	Provence Ave and Portobello Blvd
										98	Richmond Rd
										99	Richmond Rd over Hwy 417
										100	Riverdale Ave and Neighbourhood Connections
										101	Riverside Dr
										102	Russell Rd, St-Laurent Blvd and Lancaster Rd
										103	Sawmill Creek Connection from Walkley Rd
										104	Smyth Rd and Rideau River Eastern Pathway Connection
										105	Sussex Dr
										106	Somerset St East Cycling
										107	Spratt Rd Cycling
										108	St-Joseph Blvd Cycling
										109	St-Laurent Blvd Cycling
										110	Stittsville Trans Canada Trail Crossing
										111	Strandherd Dr Eastbound
										112	Sussex Dr
										113	Terry Fox Dr Pathway
										114	Tremblay Road to Terminal Avenue
										115	Trim Road Bridge
										116	Valin St and Watters Rd
										117	Walkley Rd
										118	Wellington St
										119	West Ridge Dr
										120	Withrow Ave and Capilano Dr
										121	Woodroffe Ave Cycling
										122	Woodward Dr
										123	Youville Dr

For further details, please refer to the TMP active transportation project list or GeoOttawa (<https://maps.ottawa.ca/geottawa/>)



# APPENDIX H

## Vehicle Maneuverability Diagrams

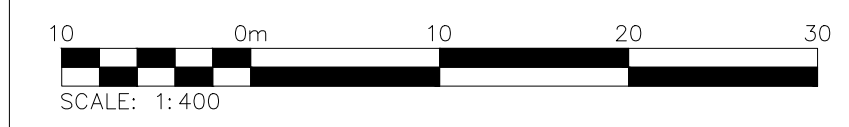

**FOR REVIEW**  
 NOT TO BE USED FOR CONSTRUCTION

No.	ISSUE	DATE: MM/DD/YYYY
1	ISSUED FOR REVIEW	04/02/2026

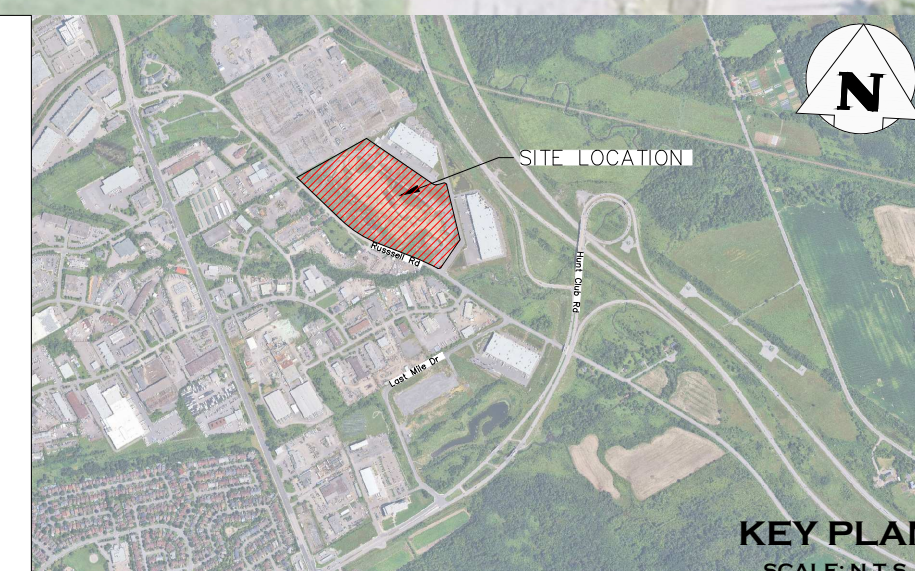
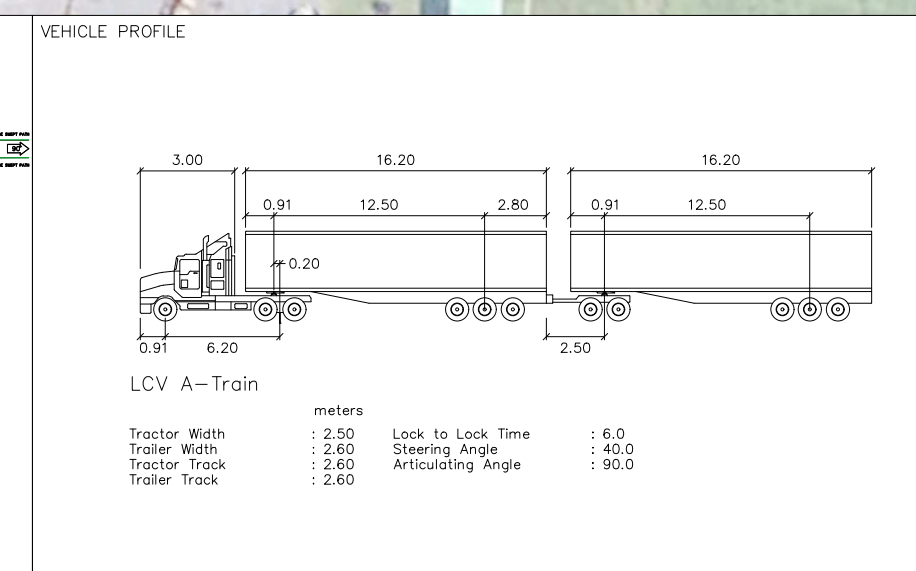
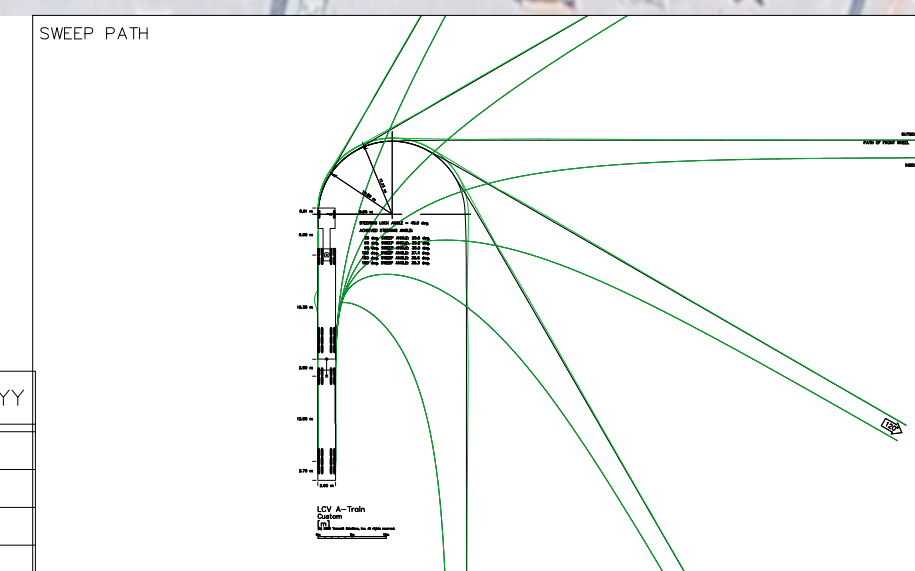

Project: 4055 RUSSELL ROAD (BUILDING A1&A3)  
 CITY OF OTTAWA  
 Drawing: SITE A1 & A3 EXTERNAL SITE ACCESS  
 AND RUSSELL RD  
 LCV A-TRAIN MANEUVERING

**CROZIER**  
 CONSULTING ENGINEERS

211 YONGE STREET  
 SUITE 600  
 TORONTO, ON, M5B 1M4  
 416-477-3392 T  
 WWW.CROZIER.CA

Drawn By: I.A.    Design By:    Project: 1909-5877  
 Check By: P.A.    Check By:    Scale: 1:400    Drawing: T101

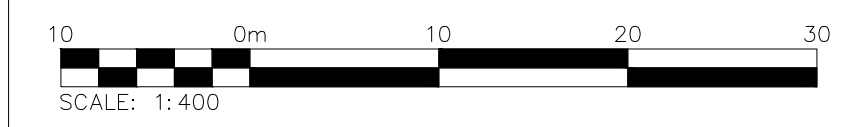

**FOR REVIEW**  
NOT TO BE USED FOR CONSTRUCTION

No.	ISSUE	DATE: MM/DD/YYYY
1	ISSUED FOR REVIEW	04/02/2026

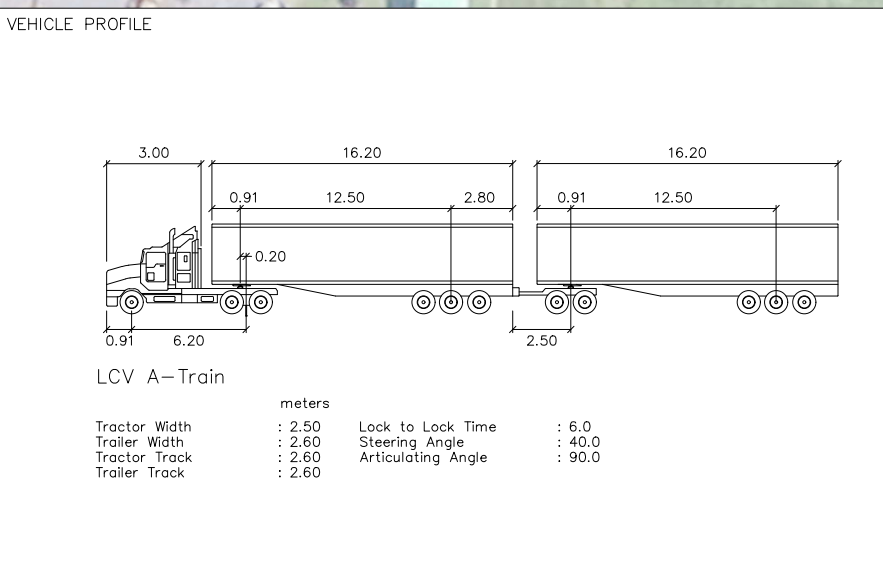
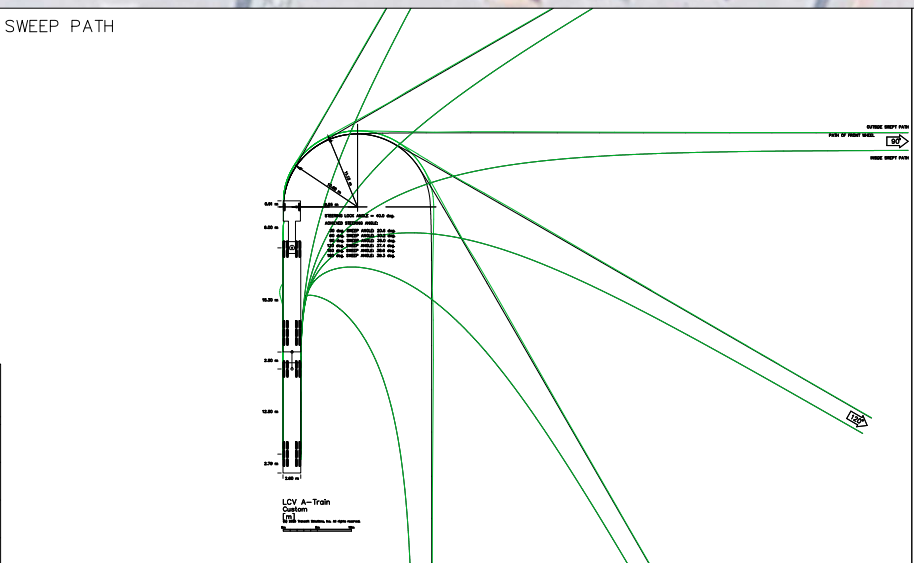

Project: 4055 RUSSELL ROAD (BUILDING A1&A3)  
CITY OF OTTAWA

Drawing: SITE A1 & A3 EXTERNAL SITE ACCESS  
AND RUSSELL RD  
LCV A-TRAIN MANEUVERING

**CROZIER**  
CONSULTING ENGINEERS

211 YONGE STREET  
SUITE 600  
TORONTO, ON, M5B 1M4  
416-477-3392 T  
www.crozier.ca  
www.crozier.us

Drawn By	I.A.	Design By		Project	1909-5877
Check By	P.A.	Check By		Scale	1:400
				Drawing	T102

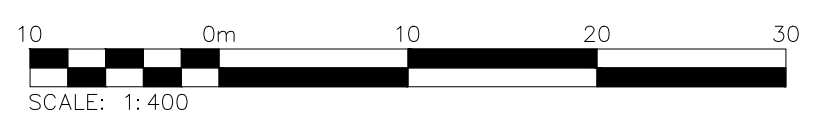

FOR REVIEW  
NOT TO BE USED FOR CONSTRUCTION

No.	ISSUE	DATE: MM/DD/YYYY
1	ISSUED FOR REVIEW	04/02/2026

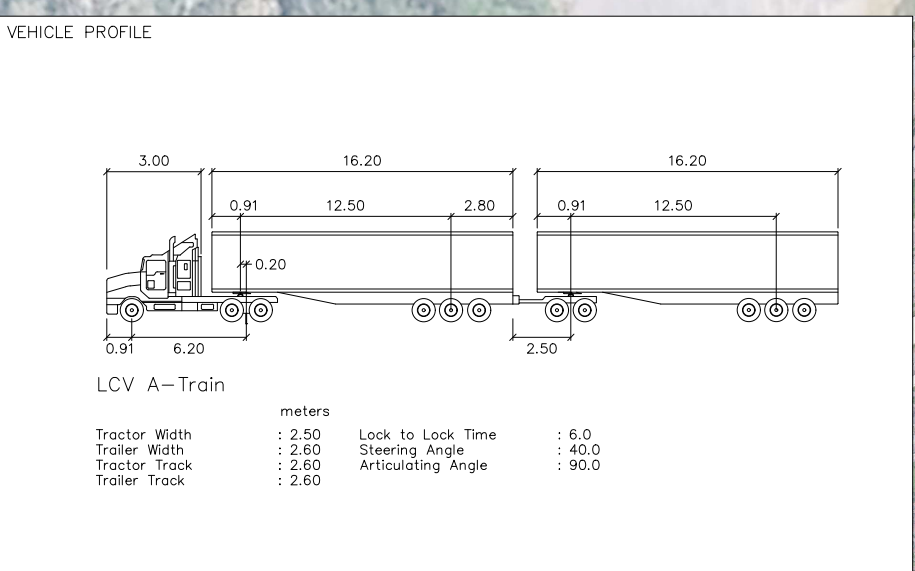
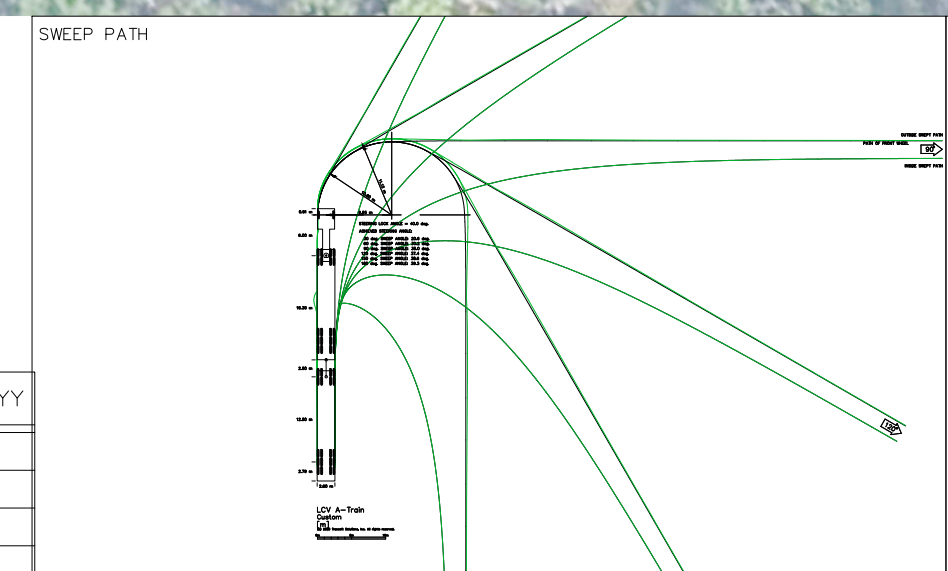

Project: 4055 RUSSELL ROAD (BUILDING A1&A3)  
CITY OF OTTAWA

Drawing: SITE A1 & A3 INTERNAL SITE ACCESS  
AND LOGISTICS PRIVATE RD  
LCV A-TRAIN MANEUVERING

**CROZIER**  
CONSULTING ENGINEERS

211 YONGE STREET  
SUITE 600  
TORONTO, ON, M5B 1M4  
416-477-3392 T  
www.crozier.ca  
www.pcrubber.ca

Drawn By: I.A. Design By: P.A. Project: 1909-5877  
Check By: P.A. Scale: 1:400 Drawing: T103

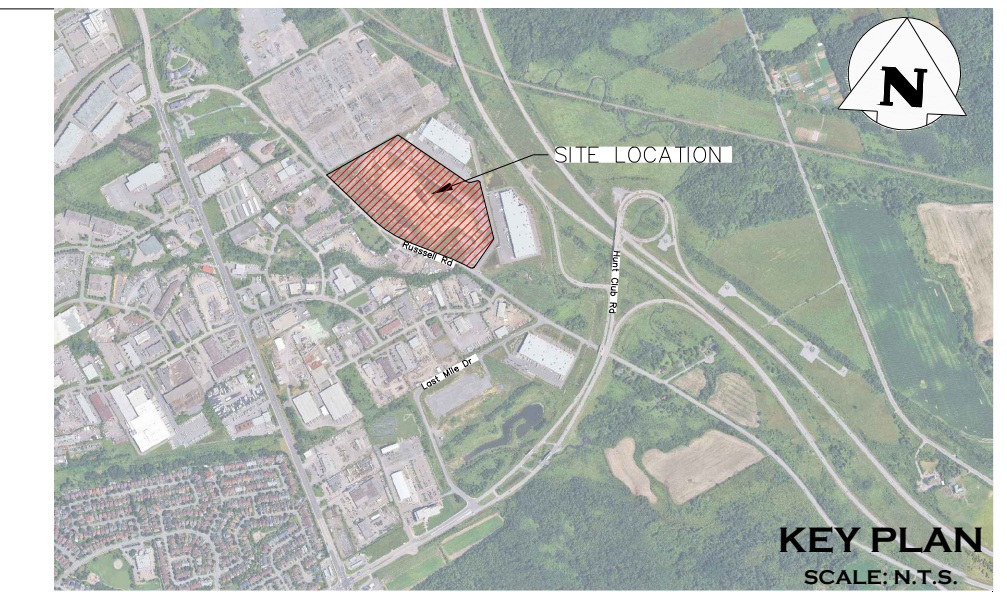
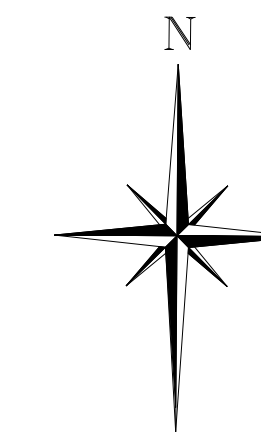

**FOR REVIEW**  
 NOT TO BE USED FOR CONSTRUCTION

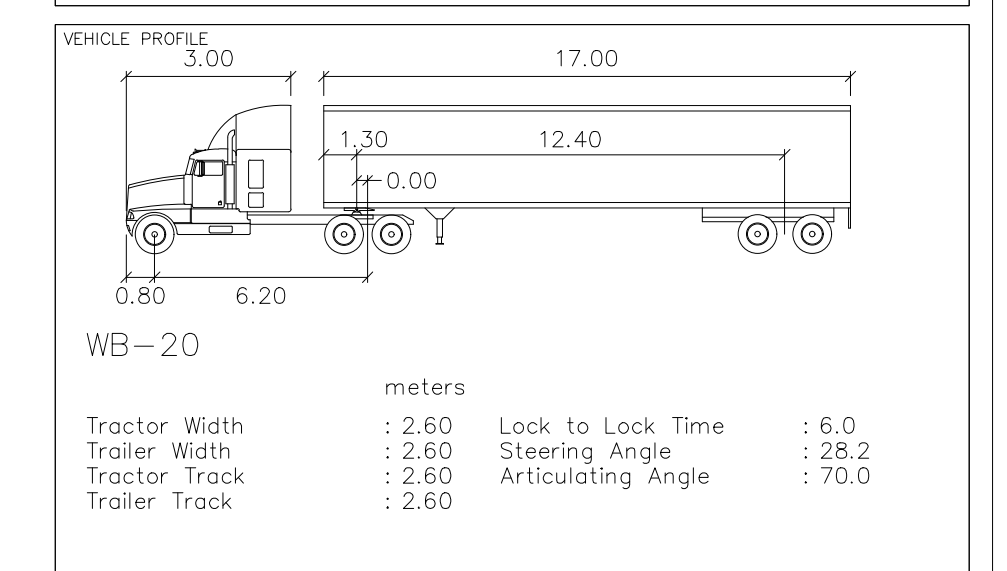
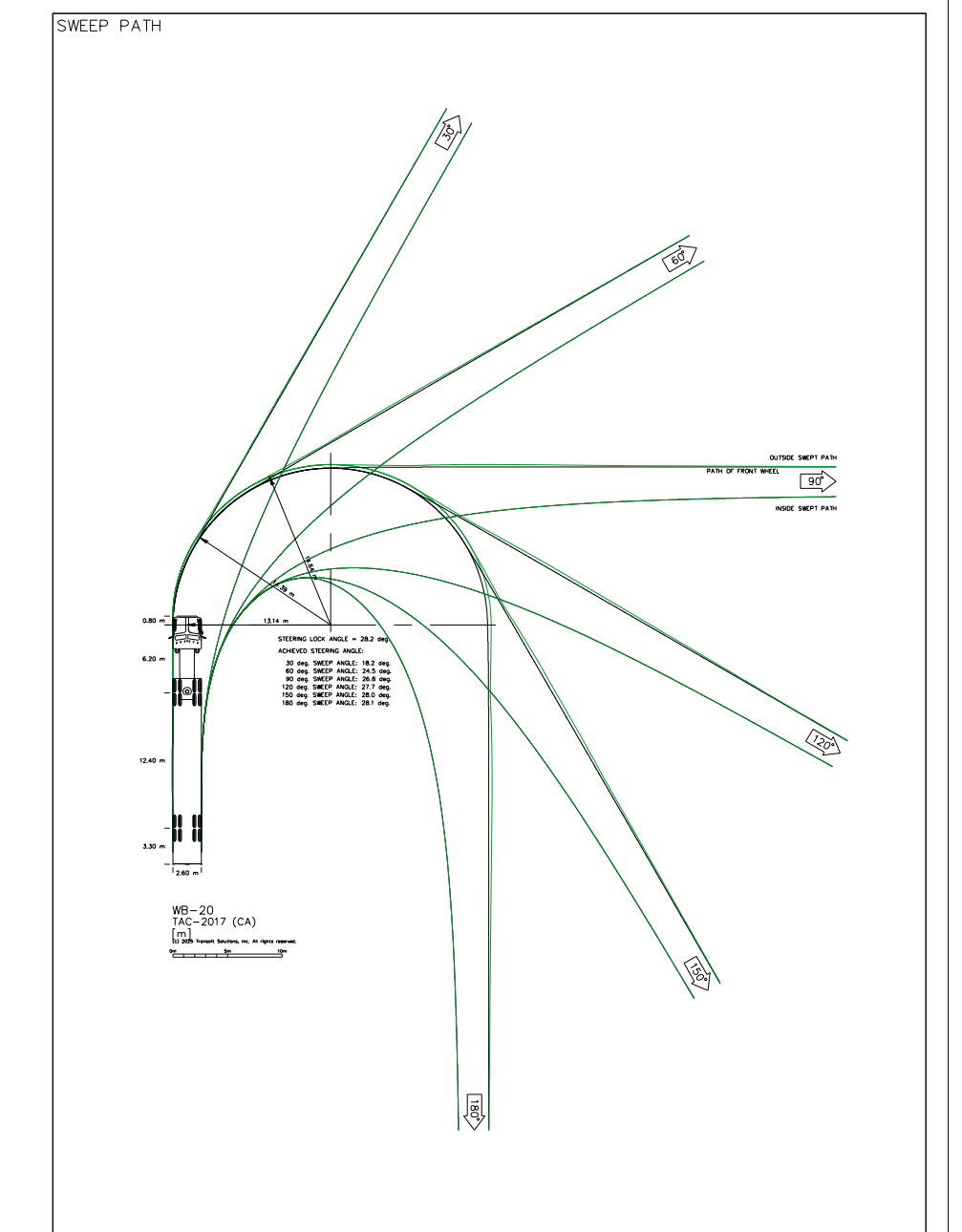
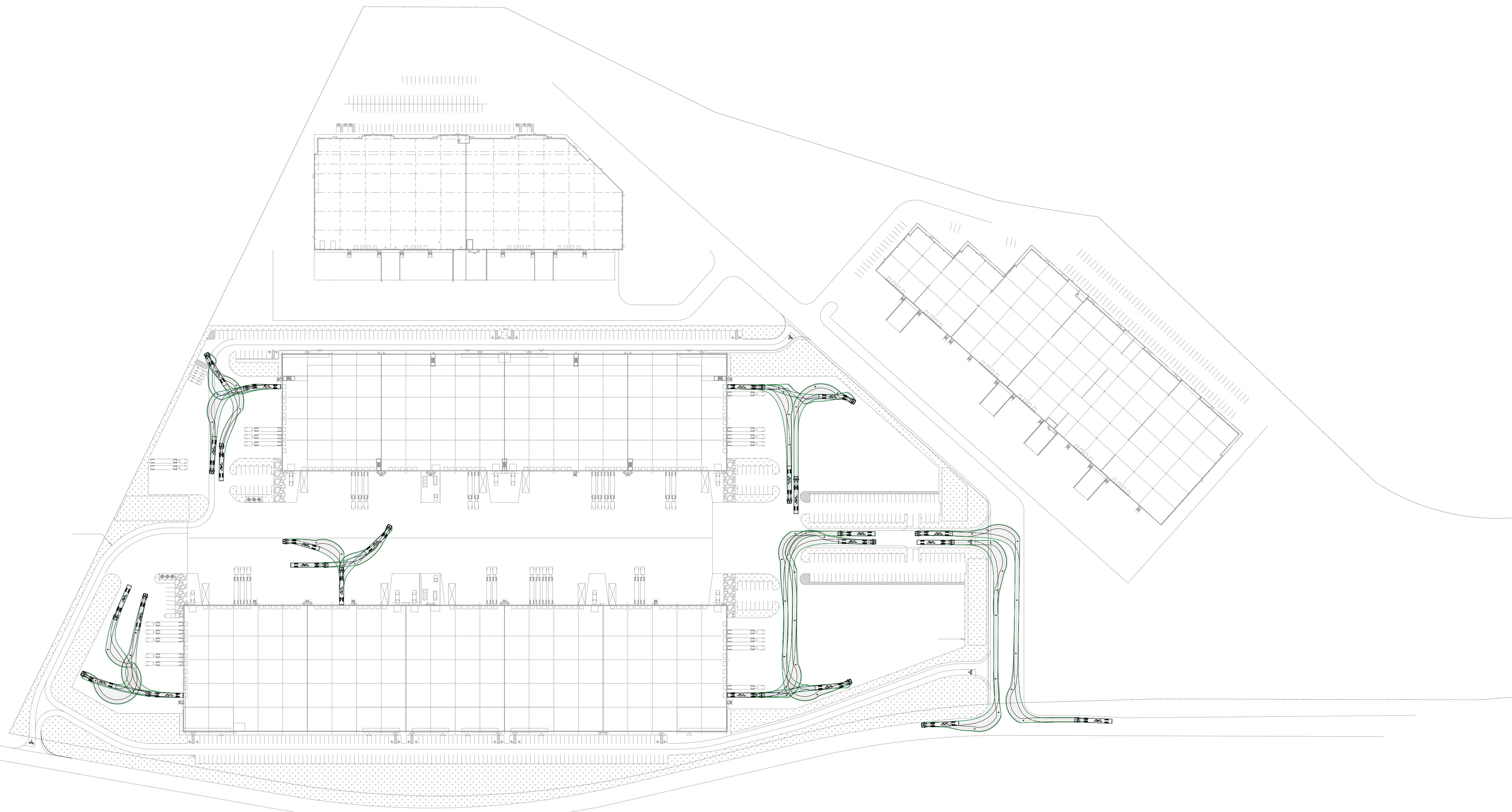

No.	ISSUE	DATE: MM/DD/YYYY
1	ISSUED FOR SUBMISSION	12/17/2025

Project  
 4055 RUSSELL ROAD (SITE A1 & A3)  
 CITY OF OTTAWA

Drawing  
 VEHICLE MANEUVERING ANALYSIS  
 WB-20 TRUCK

**CROZIER**  
CONSULTING ENGINEERS

211 YONGE STREET  
SUITE 600  
TORONTO, ON, M5B 1M4  
416-477-3392 T  
WWW.CFCROZIER.CA  
INFO@CFCROZIER.CA

Drawn By	I.A.	Design By	Project	1909-5877
Check By	P.A.	Check By	A.H.	Scale 1:1500 Drawing T300

