

Stormwater Management - Grading & Drainage - Storm & Sanitary Sewers - Watermains

700 Long Point Circle
Ottawa, Ontario K1T 4E9

613-425-8044
d.gray@dbgrayengineering.com

SITE SERVICING & STORMWATER MANAGEMENT REPORT

DICKIE MOORE RENTALS
1547 LAGAN WAY
OTTAWA, ONTARIO

REPORT No. 24022

DECEMBER 16, 2025
REVISE FEBRUARY 5, 2026

CONTENTS

- 1.0 INTRODUCTION
- 2.0 WATER SERVICING
 - 2.1 WATER SUPPLY FOR FIREFIGHTING
 - 2.2 DOMESTIC WATER SUPPLY
- 3.0 SANITARY SERVICING
- 4.0 STORMWATER MANAGEMENT
 - 4.1 QUANTITY CONTROL
 - 4.2 QUALITY CONTROL
 - 4.3 STORM SERVICING
- 5.0 CONCLUSIONS

LIST OF APPENDICES

- A WATER SERVICING
- B SANITARY SERVICING
- C STORMWATER MANAGEMENT

1.0 INTRODUCTION

This report has been prepared in support of the Site Plan Control application for the proposed and future light industrial warehouses located at 1547 Lagan Way in Ottawa, Ontario. This report describes the servicing for the proposed and future buildings and stormwater management for the 1.6 ha of developed property. The property is currently occupied by a light industrial warehouse to be demolished.

This report forms part of the site servicing and stormwater management design for the proposed development. Also refer to drawings C-1 to C-13 prepared by D.B. Gray Engineering Inc.

2.0 WATER SERVICING

2.1 WATER SUPPLY FOR FIREFIGHTING

The proposed building will have a fully supervised sprinkler system with the fire department connection located at the SW corner of the building. The future building will have a sprinkler system with the fire department connection located at the NW corner of the building. The sprinkler systems are to be designed, installed and maintained in accordance with NFPA standards and the Fire Underwriters Survey. Refer to Appendix A. There is an existing municipal Class AA fire hydrant located at the SW corner of the proposed building and NW corner of the future building. It is 25 m unobstructed distance to the proposed fire department connection for the proposed building, and 35 m unobstructed distance to the proposed fire department connection for the future building, which is less than the maximum 45 m required by the Ontario Building Code; therefore, a private fire hydrant is not required.

In accordance with City of Ottawa Technical Bulletin IWSTB-2024-05, when calculating the required fire flow on private property in urban areas, the Ontario Building Code Method is to be used. Using the Ontario Building Code Method, the required fire flow is calculated to be 9,000 L/min (150 L/s) for the proposed and future buildings. In accordance with City of Ottawa Technical Bulletin IWSTB-2024-05, when the Ontario Building Code Method yields a required fire flow of 9,000 L/min (150 L/s), the Fire Underwriters Survey Method is to be used instead. Using the Fire Underwriters Survey Method, the required fire flow is calculated to be 9,000 L/min (150 L/s) for the proposed building, and 6,000 L/min (100 L/s) for the future building. Refer to calculations in Appendix A.

The City of Ottawa indicated that 165 L/s is available. Refer to Appendix A. Therefore, there is an adequate water supply for firefighting from the existing municipal water distribution system.

In accordance with City of Ottawa Technical Bulletin ISTB-2018-02, the aggregate flow of all contributing fire hydrants within 150 m of the building shall not be less than the required fire flow. In accordance with City of Ottawa Technical Bulletin ISTB-2018-02 Appendix I:

Class	Distance (m)	Contribution (L/min)
AA	≤ 75	5,700
	> 75 and ≤ 150	3,800

Proposed Building

The existing municipal Class AA fire hydrant serving the fire department connection discussed above can contribute 5,700 L/min (95 L/s). There is another existing municipal Class AA fire hydrant within 75 m of the proposed building located at the NW corner of the proposed building. It can also contribute 5,700 L/min (95 L/s). The aggregate flow of the two contributing fire hydrants is 11,400 L/min (190 L/s), which is greater than the required fire flow of 9,000 L/min (150 L/s).

Future Building

The existing municipal Class AA fire hydrant serving the fire department connection discussed above can contribute 5,700 L/min (95 L/s). There is also an existing municipal Class AA fire hydrant within 150 m of the future building located at the NW corner of the proposed building. It can contribute 3,800 L/min (63.3 L/s). The aggregate flow of the two contributing fire hydrants is 9,500 L/min (158.3 L/s), which is greater than the required fire flow of 6,000 L/min (100 L/s).

2.2 DOMESTIC WATER SUPPLY

In accordance with

- i. the City of Ottawa Sewer Design Guidelines Appendix 4-A for the daily flows, and
- ii. the City of Ottawa Water Design Guidelines for the peaking factors, and

based on the 41 – proposed building employees, 16 – small car washes per day, 16 – large car washes per day, 10 – proposed building floor drains, 16 – future building employees and 8 – future building floor drains, the average daily demand is calculated to be 0.2 L/s, the maximum daily demand is calculated to be 0.4 L/s and the maximum hourly demand is calculated to be 0.6 L/s. Refer to calculations in Appendix A.

The boundary conditions in the 200 mm Lagan Way municipal watermain provided by the City of Ottawa at the subject property indicate a minimum HGL of 110.5 m and a maximum HGL of 118.2 m. Refer to Appendix A. Based on these boundary conditions, the pressure at the water meter is calculated to vary between 440 kPa (64 psi) and 515 kPa (75 psi) at the proposed building, and 395 kPa (57 psi) and 470 kPa (68 psi) at the future building. This is an acceptable range for the proposed development.

A 150 mm private watermain connecting to the existing 200 mm Lagan Way municipal watermain is proposed to service the development. 150 mm water services connecting to the proposed 150 mm private watermain are proposed to service the sprinkler system of each building. The same 150 mm water services will provide an adequate domestic water supply.

3.0 SANITARY SERVICING

In accordance with

- iii. the City of Ottawa Sewer Design Guidelines for the average daily flow and peaking factor, and
- iv. City of Ottawa Technical Bulletin ISTB-2018-01 for the infiltration allowance,

the post-development sanitary flow rate is calculated to be 4.66 L/s. Refer to calculations in Appendix B.

150 mm sanitary sewer services at 1% slope (14.43 L/s capacity) are proposed to service each building. Refer to calculations in Appendix B. The proposed sanitary sewer services will connect to the proposed private sanitary sewer system.

A 200 mm private sanitary sewer at 0.65% slope (26.80 L/s capacity) is proposed to service the development. At the design flow rate the 200 mm sanitary sewer will only be at 17% capacity. The proposed 200 mm sanitary sewer will connect to the existing 250 mm Lagan Way municipal sanitary sewer, which at 0.38% slope has a capacity of 37.05 L/s. Refer to calculations in Appendix B.

The pre-development sanitary flow rate is calculated to be 4.66 L/s. Refer to calculations in Appendix B. The proposed development is expected to have a negligible impact on the existing municipal sanitary sewer.

The basement plumbing fixtures will drain to a sanitary sump and be pumped to a sanitary drain. The point of connection to the sanitary drain is to be at high level in the basement. Refer to mechanical.

4.0 STORMWATER MANAGEMENT

4.1 QUANTITY CONTROL

The stormwater quantity control criterion is to control the post-development 100-year peak flow rate to the pre-development 2-year peak flow rate using a calculated pre-development runoff coefficient not more than 0.5 and a calculated pre-development time of concentration not less than 10 minutes. It is calculated that the pre-development conditions reflect a 5-year runoff coefficient of 0.74. The 5-year runoff coefficients are increased by 25% to a maximum of 1.00 to calculate the 100-year runoff coefficient. It is calculated that the pre-development conditions reflect a 100-year runoff coefficient of 0.89. Using the Bransby Williams Formula, the pre-development time of concentration is calculated to be 9 minutes. Using the Rational Method with a time of concentration of 10 minutes, the pre-development flow rates are calculated to be 724.75 L/s during the 100-year event and 350.73 L/s during the 5-year event. Using the Rational Method with a time of concentration of 10 minutes and runoff coefficient of 0.5, the maximum allowable release rate is calculated to be 174.94 L/s. The Rational and Modified Rational Methods are used to calculate the post-development flow rates and corresponding storage volumes. Refer to calculations in Appendix C.

Drainage Area I (Uncontrolled Flow Off Site – 1,321 sq.m)

The flow rates are calculated at a time of concentration of 10 minutes.

	100-Year Event	5-Year Event
Maximum Flow Rate	34.56 L/s	17.55 L/s

Drainage Area II (Proposed Building Roof – 2,250 sq.m)

The 6 roof drains are to be flow control type roof drains, which will restrict the flow of stormwater and cause it to pond on the roof. Each roof drain is to be installed with a single-parabolic slotted weir and release 0.01242 L/s/mm (5 USgpm/in). Roof drains are to be Watts with an Accutrol Weir RD-100-A1 or approved equivalent. The opening at the top of the flow control weir is to be a minimum 50 mm in diameter. A minimum of 12 scuppers each a minimum 550 mm wide are to be installed 150 mm above the roof drains. Refer to architectural for exact locations and details. The roof is to be designed to carry the load of water having a 50 mm depth at the scuppers (i.e. 200 mm depth at the roof drains). Refer to structural.

	100-Year Event	5-Year Event
Maximum Release Rate	10.73 L/s	8.26 L/s
Maximum Depth at Roof Drains	144 mm	111 mm
Maximum Volume Stored	87.83 cu.m	40.02 cu.m

Drainage Area III (Future Building Roof – 910 sq.m)

The 3 roof drains are to be flow control type roof drains, which will restrict the flow of stormwater and cause it to pond on the roof. Each roof drain is to be installed with a single-parabolic slotted weir and release 0.01242 L/s/mm (5 USgpm/in). Roof drains are to be Watts with an Accutrol Weir RD-100-A1 or approved equivalent. The opening at the top of the flow control weir is to be a minimum 50 mm in diameter. A minimum of 6 scuppers each a minimum 450 mm wide are to be installed 150 mm above the roof drains. Refer to architectural for exact locations and details. The roof is to be designed to carry the load of water having a 50 mm depth at the scuppers (i.e. 200 mm depth at the roof drains). Refer to structural.

	100-Year Event	5-Year Event
Maximum Release Rate	5.11 L/s	3.92 L/s
Maximum Depth at Roof Drains	137 mm	105 mm
Maximum Volume Stored	33.37 cu.m	15.05 cu.m

Drainage Area IV (6,783 sq.m)

An inlet control device (ICD) located in the outlet pipe of CB/MH-13 will restrict the flow of stormwater and cause it to backup into the upstream infrastructure and pond above CB-4, CB/MH-5, CB-6, CB-7, CB-8, CB/MH-9, CB-10 and CB/MH-11. The ICD will be a plug style with a round orifice located at the bottom of the plug manufactured by Pedro Plastics or approved equivalent sized by the manufacturer for a release rate of 53.32 L/s at 1.93 m. It is calculated that an orifice area of 14,201 sq.mm (± 134 mm dia) with a discharge coefficient of 0.61 will restrict the maximum flow rate to 53.32 L/s at 1.93 m. Based on this orifice, the maximum flow rate during the 5-year event is calculated to be 38.66 L/s at 1.02 m. Since some of the restricted stormwater is proposed to be stored using underground infrastructure, an average release rate equal to 50% of the maximum release rate is used to calculate the required storage volumes. The underground infrastructure will include 18 – Soleno HydroStor HS180 chambers or approved equivalent surrounded by clear stone wrapped in geotextile fabric.

	100-Year Event	5-Year Event
Maximum Release Rate	53.32 L/s	38.66 L/s
Maximum Water Elevation	68.73 m	67.81 m
Maximum Volume Stored	278.31 cu.m	120.67 cu.m

Drainage Area V (5,122 sq.m)

An ICD located in the outlet pipe of CB/MH-23 will restrict the flow of stormwater and cause it to backup into the upstream infrastructure and pond above CB-14, CB/MH-15, CB-16, CB/MH-17, CB/MH-18, CB/MH-19, CB-20, CB-21, CB/MH-22 and CB/MH-23. The ICD will be a plug style with a round orifice located at the bottom of the plug manufactured by Pedro Plastics or approved equivalent sized by the manufacturer for a release rate of 71.23 L/s at 2.18 m. It is calculated that an orifice area of 17,835 sq.mm (± 151 mm dia) with a discharge coefficient of 0.61 will restrict the maximum flow rate to 71.23 L/s at 2.18 m. Based on this orifice, the maximum flow rate during the 5-year event is calculated to be 69.32 L/s at 2.07 m.

	100-Year Event	5-Year Event
Maximum Release Rate	71.23 L/s	69.32 L/s
Maximum Water Elevation	69.02 m	68.90 m
Maximum Volume Stored	110.09 cu.m	30.20 cu.m

Summary

The maximum post-development release rate during the 100-year event is calculated to be 174.94 L/s, which is 76% less than the pre-development flow rate during the 100-year event and equal to the maximum allowable release rate. To achieve the maximum allowable release rate, a maximum storage volume of 509.59 cu.m is required and provided during the 100-year event. The maximum post-development release rate during the 5-year event is calculated to be 137.70 L/s, which is 61% less than the pre-development flow rate during the 5-year event and 21% less than the maximum allowable release rate. A maximum storage volume of 205.93 cu.m is required and provided during the 5-year event. The post-development reduction in flow is expected to have a positive impact on the 600 mm Lagan Way municipal storm sewer.

	100-Year Event	5-Year Event
Pre-Development Flow Rate	724.75 L/s	350.73 L/s
Maximum Allowable Release Rate	174.94 L/s	174.94 L/s
Maximum Release Rate	174.94 L/s	137.70 L/s
Maximum Volume Required	509.59 cu.m	205.93 cu.m
Maximum Volume Stored	509.59 cu.m	205.93 cu.m

4.2 QUALITY CONTROL

The stormwater quality control criterion is to provide an enhanced (80% TSS removal) level of protection. An oil grit separator (OGS) manhole is proposed to be located downstream of the inlet control devices. Calculations by the manufacturer indicate that the CDS PMSU-3020-6 OGS will remove 81.0% of total suspended solids. Refer to calculations in Appendix C.

An Erosion & Sediment Control Plan has been developed to be implemented during construction. Refer to drawing C-8 and C-9 and notes on drawing C-12. Sediment capture filter sock inserts are to be installed in all existing and proposed catch-basins and catch-basin/manholes adjacent to and within the site, and any material deposited on the public road is to be removed.

4.3 STORM SERVICING

The peak unrestricted proposed building roof flow rate during the 2-year event is calculated to be 48.5 L/s. A 300 mm storm sewer service at 2% slope (135.5 L/s capacity) is proposed to service the proposed building. At the design flow rate the storm sewer service will only be at 36% capacity. The proposed 300 mm storm sewer service will connect to the proposed private storm sewer system downstream of the ICDs. Refer to calculations in Appendix C.

The peak unrestricted future building roof flow rate during the 2-year event is calculated to be 17.5 L/s. A 200 mm storm sewer service at 2% slope (47.0 L/s capacity) is proposed to service the future building. At the design flow rate the storm sewer service will only be at 37% capacity. The proposed 200 mm storm sewer service will connect to the proposed private storm sewer system downstream of the ICDs. Refer to calculations in Appendix C.

The peak unrestricted flow rate draining into the private storm sewer system during the 2-year event is calculated to be 240.2 L/s. A 525 mm storm sewer at 0.3% slope (245.2 L/s capacity) is proposed to connect to the existing 600 mm Lagan Way municipal storm sewer, which at 0.36% slope has a capacity of 385.0 L/s. At the design flow rate the proposed 525 mm storm sewer will be at 98% capacity. Refer to calculations in Appendix C.

The rainwater leaders inside the buildings are to be constructed to withstand the pressure from a water column the height of the rainwater leader. Pressure tests are to be performed on the systems in accordance with the mechanical engineer's instructions.

The foundation drains will drain to a storm sump and be pumped to a storm drain. The point of connection to the storm drain is to be at high level in the basement. Refer to mechanical.

5.0 CONCLUSIONS

1. A private fire hydrant is not required.
2. There is an adequate water supply for firefighting from the existing municipal water distribution system.
3. There is an acceptable range of water pressures in the existing municipal water distribution system.
4. The post-development sanitary flow rates will be adequately handled by the proposed sanitary sewer services and private sanitary sewer system.
5. The proposed development is expected to have a negligible impact on the existing municipal sanitary sewer.
6. The maximum post-development release rate during the 100-year event will be equal to the maximum allowable release rate.
7. The post-development reduction in stormwater flow is expected to have a positive impact on the existing municipal storm sewer.
8. The proposed OGS will provide an enhanced (80% TSS removal) level of protection.
9. An Erosion & Sediment Control Plan has been developed to be implemented during construction.
10. The peak unrestricted flow rates during the 2-year event will be adequately handled by the proposed storm sewer services and private storm sewer system.
11. The rainwater leaders inside the buildings are to be constructed to withstand the pressure from a water column the height of the rainwater leader. Pressure tests are to be performed on the systems in accordance with the mechanical engineer's instructions.

Prepared by D.B. Gray Engineering Inc.

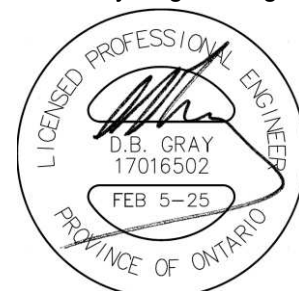

APPENDIX A

WATER SERVICING

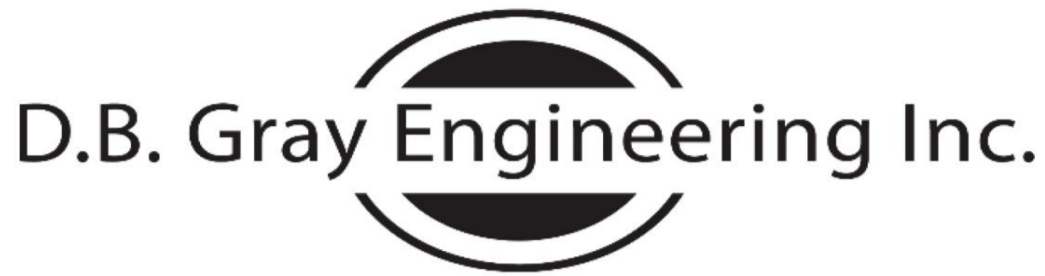

Stormwater Management - Grading & Drainage - Storm & Sanitary Sewers - Watermains

700 Long Point Circle
Ottawa, Ontario K1T 4E9

613-425-8044
d.gray@dbgrayengineering.com

October 28, 2025

1547 Lagan Way
2 Proposed Warehouse Buildings
Ottawa, Ontario

FIRE FLOW CALCULATIONS FUS Method

Proposed Building

RFF = Required Fire Flow in litres per minute
= $220CA^{0.5}$

C = Construction Coefficient related to the type of construction of the building
= 1.5 Type V Wood Frame Construction

A = Total Effective Floor Area in square meters of the building

Mezzanine: 665 sq.m

1st Floor: 2,240 sq.m

2,905 sq.m

RFF = 17,786 L/min
= 18,000 L/min (rounded to nearest 1,000 L/min)

Occupancy and Contents Adjustment Factor

-2% 0% Charge for combustible Occupancy (461 sq.m. Salesroom)
15% Charge for Free-burning Occupancy (1074 sq.m. Repair garage)
-15% Charge for Limited-burning Occupancy (1370 sq.m. Offices)

= -275 L/min Occupancy and Contents Adjustment Factor

RFF = 17,725 L/min

Automatic Sprinkler Protection Credit

30% Sprinkler system designed, installed and maintained in accordance with NFPA standards
10% Standard water supply for both the sprinkler system and fire department hose lines
10% Fully supervised sprinkler system

= 8,862 L/min Automatic Sprinkler Protection Credit

Exposure Adjustment Charge						
Side	Charge	Distance	Construction	Length	Storeys	Factor
North	0%	over 30 m				
East	0%	over 30 m				
South	0%	over 30 m				
West	0%	over 30 m				

0% Exposure Adjustment Charge
 = 0 L/min Exposure Adjustment Charge

RFF = 8,862 L/min
 = 9,000 L/min (rounded to nearest 1,000 L/min)
 = 150.0 L/s

Future Building

RFF = Required Fire Flow in litres per minute
 = $220CA^{0.5}$

C = Construction Coefficient related to the type of construction of the building
 = 1.5 Type V Wood Frame Construction

A = Total Effective Floor Area in square meters of the building
 1st Floor: 910 sq.m
 910 sq.m

RFF = 9,955 L/min
 = 10,000 L/min (rounded to nearest 1,000 L/min)

Occupancy and Contents Adjustment Factor
 15% Charge for Free-burning Occupancy

= 1,500 L/min Occupancy and Contents Adjustment Factor

RFF = 11,500 L/min

Automatic Sprinkler Protection Credit
 30% Sprinkler system designed, installed and maintained in accordance with NFPA standards
 10% Standard water supply for both the sprinkler system and fire department hose lines

= 4,000 L/min Automatic Sprinkler Protection Credit

Exposure Adjustment Charge						
Side	Charge	Distance	Construction	Length	Storeys	Factor
North	0%	over 30 m				0
East	0%	over 30 m				
South	4%	20.1 m to 30 m	Type V	23	2	46
West	0%	over 30 m				

4% Exposure Adjustment Charge
 = 400 L/min Exposure Adjustment Charge

RFF = 6,400 L/min
 = 6,000 L/min (rounded to nearest 1,000 L/min)
 = 100.0 L/s

WATER SUPPLY
FOR
PUBLIC FIRE PROTECTION

*A Guide to Recommended Practice
in Canada*

2020



Fire Underwriters Survey

Automatic Sprinkler Protection

The required fire flow may be reduced by up to 50 percent for complete Automatic Sprinkler Protection depending upon adequacy of the system. Where only part of a building is protected by Automatic Sprinkler Protection, credit should be interpolated by determining the percentage of the Total Floor Area being protected by the automatic sprinkler system.

To be able to apply the full 50 percent reduction, the following areas should be reviewed to determine the appropriate level of credit for having Automatic Sprinkler Protection as per the table below:

Table 4 Sprinkler Credits

Automatic Sprinkler System Design	Credit	
	With complete building coverage	With partial building coverage of X%
Automatic sprinkler protection designed and installed in accordance with NFPA 13	30%	$30\% \times \text{Percentage of Total Floor Area Served by Sprinkler System}$
Water supply is standard for both the system and Fire Department hose lines	10%	$10\% \times \text{Percentage of Total Floor Area Served by Sprinkler System}$
Fully supervised system	10%	$10\% \times \text{Percentage of Total Floor Area Served by Sprinkler System}$

Automatic Sprinkler Protection Designed and Installed in Accordance with Applicable NFPA Standards (30%)

The initial credit for Automatic Sprinkler Protection is a maximum of 30% based on the system being designed and installed in accordance with the applicable criteria of NFPA 13, *Standard for Installation of Sprinkler Systems*, NFPA 13R, *Standard for the Installation of Sprinkler Systems in Low-Rise Residential Occupancies*, or NFPA 13D, *Standard for the Installation of Sprinkler Systems in One- and Two-Family Dwellings and Manufactured Homes* and being maintained in accordance with the applicable criteria of NFPA 25, *Standard for the Inspections, Testing and Maintenance of Water-Based Fire* (see Recognition of Automatic Sprinkler Protection).

Water Supply is Standard for both the Sprinkler System and Fire Department Hose Lines (10%)

To qualify to apply an additional 10% reduction, a water supply that is standard for both the sprinkler system and fire department hose lines is required, to qualify the following conditions should be satisfied:

- a) Sprinkler system is supplied by a pressurized water supply system (public or private) that is designed and built with no major non-conformance issues (i.e. water supply system is designed in accordance with Part 1 of the Water Supply for Public Fire Protection to qualify for fire insurance grading recognition).
- b) Calculated demand for maximum sprinkler design area operation in addition to hose stream requirements are below the available water supply curve (at the corresponding flow rate and pressure). An appropriate safety margin is used to take into account the difference between the available water supply curve at the time of hydrant flow testing as compared to the available water supply curve during Maximum Day Demand.

- c) Volume of water available is adequate for the total flow rate including the maximum sprinkler design area operation plus required hose streams plus Maximum Day Demand for the full duration of the design fire event.
- d) Residual pressure at all points in the water supply system can be maintained at not less than 150 kPa during the flowing of the sprinkler and required hose streams (plus Maximum Day Demand).

Fully Supervised System (10%)

To qualify to apply an additional 10% reduction, an automatic sprinkler system should be fully supervised. The purpose of the supervisory signal is to ensure that malfunctions of the automatic sprinkler system will be discovered and corrected promptly, while the water flow alarm serves to notify emergency services of the fire as soon as the automatic sprinkler system activates.

- a distinctive supervisory signal to indicate conditions that could impair the satisfactory operation of the sprinkler system (a fault alarm), which is to sound and be displayed, either at a location within the building that is constantly attended by qualified personnel (such as a security room), or at an approved remotely located receiving facility (such as a monitoring facility of the sprinkler system manufacturer); and
- a water flow alarm to indicate that the sprinkler system has been activated, which is to be transmitted to an approved, proprietary alarm-receiving facility, a remote station, a central station or the fire department.

Additional Reductions for Community Level Automatic Sprinkler Protection of Area

Buildings located within communities or subdivisions that are completely sprinkler protected may apply up to a maximum additional 25% reduction in required fire flows beyond the normal maximum of 50% reduction for sprinkler protection of an individual building.

This additional reduction may be applied where all the following conditions are met:

- a) the community has a bylaw requiring all buildings that may be built within 30 m of the subject building to be fully sprinkler protected. I.e. future development will not create unsprinklered buildings within 30 m of the subject building, and
- b) all buildings within 30 meters of the subject building are fully sprinkler protected with systems that are designed and installed in accordance with the applicable criteria of NFPA 13, *Standard for Installation of Sprinkler Systems*, NFPA 13R, *Standard for the Installation of Sprinkler Systems in Low-Rise Residential Occupancies*, or NFPA 13D, *Standard for the Installation of Sprinkler Systems in One- and Two-Family Dwellings and Manufactured Homes*, and
- c) the community has in place a Fire Prevention Program that provides a system of ensuring that installed fire sprinkler systems are inspected, tested, and maintained in accordance with NFPA 25: *Standard for the Inspection, Testing, and Maintenance of Water-Based Fire Protection Systems*, and
- d) the community maintains the pressure and flow rate requirements for fire sprinkler installations. I.e. the community does not make significant reductions to the operating pressures or flows across the distribution network.

Adjustment of Sprinkler Reductions for Community Level Oversight of Sprinkler Maintenance, Testing and Water Supply Requirements

The reduction in required fire flows for sprinkler protection may be reduced or eliminated if

- a) the community does not have a Fire Prevention Program that provides a system of ensuring that installed fire sprinkler systems are inspected, tested, and maintained in accordance with NFPA 25: *Standard for the Inspection, Testing, and Maintenance of Water-Based Fire Protection Systems*, or
- b) the community does not maintain the pressure and flow rate requirements for fire sprinkler installations, or otherwise allows the flow rates and pressure levels that were available during sprinkler system design to significantly degrade, increasing the probability of inadequate water supply for effective sprinkler operation.

Recognition of Automatic Sprinkler Protection

A property should be considered as “sprinkler protected” for the purposes of determining required fire flows, if the building has an automatic fire sprinkler system:

- designed and installed throughout all areas in accordance with NFPA 13, *Standard for Installation of Sprinkler Systems*, and maintained in accordance with the NFPA 25, *Standard for the Inspections, Testing and Maintenance of Water-Based Fire Protection Systems*, and
- supplied by water infrastructure capable of meeting all pressure and flow requirements of the sprinkler system concurrently with Max Day Demand (if connected to a domestic system)

Evidence of the sprinkler system design, installation should be acquired from the party responsible for the building (the owner, building engineer or property manager) or the municipal fire prevention office.

On site, the sprinkler system should carry test tags verifying that a qualified person has conducted tests including:

- flushing and hydrostatic tests of both the underground and overhead piping in accordance with NFPA 13;
- full-flow main drain test within the previous 48 months.
- dry-pipe trip test (if applicable) conducted within the last 48 months
- fire-pump test (if applicable) conducted within the last 48 months

Items of Note for Sprinkler Systems

- i. It is important to note that installation of automatic sprinkler systems provides a highly effective and reliable system of fire protection however, this does not preclude the need for manual fire flows entirely as some fires, for various reasons, grow beyond the capability of sprinkler protection to be effective, and in these cases, manual fire fighting intervention is required.

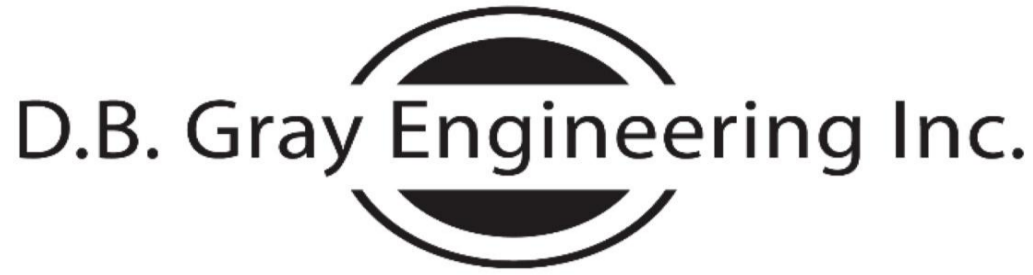

Stormwater Management - Grading & Drainage - Storm & Sanitary Sewers - Watermains

700 Long Point Circle
Ottawa, Ontario K1T 4E9

613-425-8044
d.gray@dbgrayengineering.com

December 16, 2025

1547 Lagan Way
Proposed and Future Buildings
Ottawa, Ontario

WATER DEMAND CALCULATIONS

		Proposed Building							
Employee	41	ea	75 L/day	3075 L/day					
Car wash	16	Small car per day	200 L/day	3200 L/day					
Car wash	16	Large car per day	400 L/day	6400 L/day					
Floor drain	10	ea	375 L/day	3750 L/day					
		Future Building							
Employee	16	ea	75 L/day	1200 L/day					
Floor drain	8	ea	375 L/day	3000 L/day					
			Total	20,625 L/day					
				24 hour day					
				14.3 L/min	0.2 L/s	3.8 USgpm			
			Maximum Daily Demand:	1.5	(Peaking factor as per City of Ottawa Water Design Guidelines)				
				21.5 L/min	0.4 L/s	5.7 USgpm			
			Maximum Hourly Demand:	1.8	(Peaking factor as per City of Ottawa Water Design Guidelines)				
				38.7 L/min	0.6 L/s	10.2 USgpm			

		Proposed Building			
Elevation of Water Meter:	65.66	m ASL			
Finish Floor Elevation:	64.76	m ASL			
		Static Pressure at Water Meter			
MINIMUM HGL:	110.5	m ASL	64 psi	440 kPa	
MAXIMUM HGL:	118.2	m ASL	75 psi	515 kPa	
		Future Building			
Elevation of Water Meter:	70.23	m ASL			
Finish Floor Elevation:	69.33	m ASL			
		Static Pressure at Water Meter			
MINIMUM HGL:	110.5	m ASL	57 psi	395 kPa	
MAXIMUM HGL:	118.2	m ASL	68 psi	470 kPa	

RE: Request for boundary conditions - 1547 Lagan Way

1 message

Cassidy, Tyler <tyler.cassidy@ottawa.ca>

Wed, May 14, 2025 at 9:18 AM

To: laurent Brosseau <l.brosseau@dbgrayengineering.com>

Cc: Douglas Gray <d.gray@dbgrayengineering.com>

Hi Laurent,

Please find below the boundary conditions for [1547 Lagan Way](#):

Please note that requested Fire Flow Requirements of 216.7 L/s [Building D], 200 L/s [Building C] was not met. Maximum available FF at 20psi is provided.

******The following information may be passed on to the consultant, but do NOT forward this e-mail directly.******

The following are boundary conditions, HGL, for hydraulic analysis at [1547 Lagan Way](#) (zone 1E) assumed to be connected to the 203 mm watermain on Lagan Way (see attached PDF for location).

-

Minimum HGL: 110.5 m

Maximum HGL: 118.2 m

Available fire flow at 20 psi: 165 L/s, assuming ground elevation of 69.2 m

These are for current conditions and are based on computer model simulation.

Disclaimer:

The boundary condition information is based on current operation of the city water distribution system. The computer model simulation is based on the best information available at the time. The operation of the water distribution system can change on a regular basis, resulting in a variation in boundary conditions. The physical properties of watermains deteriorate over time, as such must be assumed in the absence of actual field test data. The variation in physical watermain properties can therefore alter the results of the computer model simulation. Fire Flow analysis is a reflection of available flow in the watermain; there may be additional restrictions that occur between the watermain and the hydrant that the model cannot take into account.

"The IWSD has recently updated their water modelling software. Any significant difference between previously received BC results and newly received BC results could be attributed to this update."

Thank you,

Tyler Cassidy, P.Eng

Infrastructure Project Manager,

Planning, Development and Building Services department (PDBS)/ Direction générale des services de la planification, de l'aménagement et du bâtiment (DGSPAB) - South Branch

City of Ottawa | Ville d'Ottawa

[110 Laurier Avenue West Ottawa, ON](#) | 110, avenue. Laurier Ouest. Ottawa (Ontario)
[K1P 1J1](#)

613.580.2424 ext./poste 12977, Tyler.Cassidy@ottawa.ca

Classified as City of Ottawa - Internal / Ville d'Ottawa - classé interne

From: Cassidy, Tyler

Sent: April 16, 2025 2:43 PM

To: laurent Brosseau <l.brosseau@dbgrayengineering.com>

Cc: Douglas Gray <d.gray@dbgrayengineering.com>; Adams, Reed <reed.adams@ottawa.ca>

Subject: RE: Request for boundary conditions - [1547 Lagan Way](#)

Hi Laurent,

I've forwarded your request to our Water Resources group. Please allow for up to 10 business days for the results to be provided.

Thank you,

Tyler Cassidy, P.Eng

Infrastructure Project Manager,

Planning, Development and Building Services department (PDBS)/ Direction générale des services de la planification, de l'aménagement et du bâtiment (DGSPAB) - South Branch

City of Ottawa | Ville d'Ottawa

[110 Laurier Avenue West Ottawa, ON](#) | [110, avenue. Laurier Ouest. Ottawa \(Ontario\)](#)
[K1P 1J1](#)

[613.580.2424](tel:613.580.2424) ext./poste 12977, Tyler.Cassidy@ottawa.ca

From: Adams, Reed <reed.adams@ottawa.ca>

Sent: April 16, 2025 1:20 PM

To: laurent Brosseau <l.brosseau@dbgrayengineering.com>; Cassidy, Tyler <tyler.cassidy@ottawa.ca>

Cc: Douglas Gray <d.gray@dbgrayengineering.com>

Subject: Re: Request for boundary conditions - [1547 Lagan Way](#)

Hi Laurent,

I've cc'd Tyler who will be taking over this file and will be able to help you out.

Thanks,

Reed

Classified as City of Ottawa - Internal / Ville d'Ottawa - classé interne

From: Laurent Brosseau

Sent: Tuesday, April 15, 2025 9:33 AM

To: Adams, Reed

Cc: Douglas Gray

Subject: Request for boundary conditions - [1547 Lagan Way](#)

CAUTION: This email originated from an External Sender. Please do not click links or open attachments unless you recognize the source.

ATTENTION : Ce courriel provient d'un expéditeur externe. Ne cliquez sur aucun lien et n'ouvrez pas de pièce jointe, excepté si vous connaissez l'expéditeur.

Hi Reed,

Please provide the boundary conditions for the 200mm Lagan Way municipal watermain at [1547 Lagan Way](#). Approximate proposed point of connection is attached. We have calculated the following expected demands:

Fire flow demand: 216.7 L/s (Building D)

Average daily demand: 0.2 L/s, 17.3 cu.m/day

Maximum daily demand: 0.3 L/s
Maximum hourly demand: 0.5 L/s

Calculations are attached.

Thank you

Laurent Brosseau

D.B. Gray Engineering Inc.

700 Long Point Circle

Ottawa, Ontario K1T 4E9

613-425-8044

,

This e-mail originates from the City of Ottawa e-mail system. Any distribution, use or copying of this e-mail or the information it contains by other than the intended recipient(s) is unauthorized. Thank you.

Le présent courriel a été expédié par le système de courriels de la Ville d'Ottawa. Toute distribution, utilisation ou reproduction du courriel ou des renseignements qui s'y trouvent par une personne autre que son destinataire prévu est interdite. Je vous remercie de votre collaboration.

,

APPENDIX B

SANITARY SERVICING



SANITARY SEWER CALCULATIONS

1547 Lagan Way
Ottawa, Ontario

Residential Average Daily Flow: 280 L/capita/day
Commercial Average Daily Flow: 28,000 L/ha/day
Institutional Average Daily Flow: 28,000 L/ha/day
Light Industrial Average Daily Flow: 35,000 L/ha/day
Heavy Industrial Average Daily Flow: 55,000 L/ha/day

Residential Peaking Factor: Harmon Formula
Harmon Formula Correction Factor: 0.8
Commercial Peaking Factor: 1.5
Institutional Peaking Factor: 1.5
Industrial Peaking Factor: Ministry of the Environment

Stormwater Management - Grading & Drainage - Storm & Sanitary Sewers - Watermains
700 Long Point Circle
Ottawa, Ontario K1T 4E9

613-425-8044
d.gray@dbgrayengineering.com

December 16, 2025

Infiltration Allowance: 0.33 L/s/ha

Manning's Roughness Coefficient: 0.013

Location		Residential											Non-Residential				Infiltration			Q Total Flow Rate (L/s)	Sewer Data															
		Individual				Cumulative				Individual		Cumulative		Individual	Cumulative		Length (m)	Nominal Diameter (mm)	Actual Diameter (mm)		Slope (%)	Velocity (m/s)	Q _{Full} Capacity (L/s)	Q / Q _{Full}												
		Single Family	Semi Detached	Duplex	Apartment				Area (ha)	Population	Area (ha)	Population	Peaking Factor	Flow Rate (L/s)	Area (ha)	Daily Flow L/ha/day				Peaking Factor					Flow Rate (L/s)	Area (ha)	Area (ha)	Flow Rate (L/s)								
From	To	ppu = 3.4	ppu = 2.7	ppu = 2.3	(1 Bed) ppu = 1.4	(2 Bed) ppu = 2.1	(3 Bed) ppu = 3.1	(Average) ppu = 1.8	Area (ha)	Population	Area (ha)	Population	Peaking Factor	Flow Rate (L/s)	Area (ha)	Daily Flow L/ha/day	Peaking Factor	Flow Rate (L/s)	Area (ha)	Area (ha)	Flow Rate (L/s)	Flow Rate (L/s)														
Exist. Bld	250 SAN									0	0.0000	0	3.2	0.00	1.6627	35,000	6.1	4.11	1.6627	1.6627	0.55	4.66	15.1	150	147	1	0.85	14.43	0.32							
Prop. Bld	MH-SA.1									0	0.0000	0	3.2	0.00	0.0000	35,000	6.1	0.00	0.0000	0.0000	0.00	0.00	15.1	150	147	1	0.85	14.43	0.00							
Future Bld	MH-SA.1									0	0.0000	0	3.2	0.00	0.0000	35,000	6.1	0.00	0.0000	0.0000	0.00	0.00	25.4	150	147	1	0.85	14.43	0.00							
MH-SA.1	MH-SA.2									0	0.0000	0	3.2	0.00	1.6627	35,000	6.1	4.11	1.6627	1.6627	0.55	4.66	12.4	200	201	0.65	0.84	26.80	0.17							
MH-SA.2	250 SAN									0	0.0000	0	3.2	0.00	0.0000	35,000	6.1	4.11	0.0000	1.6627	0.55	4.66	5.9	200	201	0.65	0.84	26.80	0.17							
																						250 mm Lagan Way Sanitary Sewer:			250	251	0.38	0.75	37.05							

APPENDIX C

STORMWATER MANAGEMENT

SUMMARY TABLES

100-YEAR EVENT					
Drainage Area	Pre-Development Flow Rate (L/s)	Maximum Allowable Release Rate (L/s)	Maximum Release Rate (L/s)	Maximum Volume Required (cu.m)	Maximum Volume Stored (cu.m)
AREA I (Uncontrolled Flow Off Site)	-	-	34.56	-	-
AREA II (Proposed Building Roof)	-	-	10.73	87.83	87.83
AREA III (Future Building Roof)	-	-	5.11	33.37	33.37
AREA IV	-	-	53.32	278.31	278.31
AREA V	-	-	71.23	110.09	110.09
TOTAL	724.75	174.94	174.94	509.59	509.59

5-YEAR EVENT					
Drainage Area	Pre-Development Flow Rate (L/s)	Maximum Allowable Release Rate (L/s)	Maximum Release Rate (L/s)	Maximum Volume Required (cu.m)	Maximum Volume Stored (cu.m)
AREA I (Uncontrolled Flow Off Site)	-	-	17.55	-	-
AREA II (Proposed Building Roof)	-	-	8.26	40.02	40.02
AREA III (Future Building Roof)	-	-	3.92	15.05	15.05
AREA IV	-	-	38.66	120.67	120.67
AREA V	-	-	69.32	30.20	30.20
TOTAL	350.73	174.94	137.70	205.93	205.93

1547 Lagan Way

Ottawa, Ontario

STORMWATER MANAGEMENT CALCULATIONS

Modified Rational Method

PRE-DEVELOPMENT CONDITIONS

100-YEAR EVENT

			C
Roof Area:	1,152	sq.m	1.00
Hard Area:	3,130	sq.m	1.00
Gravel Area:	9,723	sq.m	1.00
Soft Area:	<u>2,381</u>	<u>sq.m</u>	<u>0.25</u>
Total Catchment Area:	16,386	sq.m	0.89

Bransby Williams Formula

$$T_c = \frac{0.057 \cdot L}{S_w^{0.2} \cdot A^{0.1}} \text{ min}$$

Sheet Flow Distance (L):	155	m
Slope of Land (Sw):	0.9	%
Area (A):	1.6386	ha
Time of Concentration (Sheet Flow):	8.6	min
Time of Concentration:	10	min
Rainfall Intensity (i):	179	mm/hr
100-Year Pre-Development Flow Rate (2.78AiC):	724.75	L/s

5-YEAR EVENT

			C
Roof Area:	1,152	sq.m	0.90
Hard Area:	3,130	sq.m	0.90
Gravel Area:	9,723	sq.m	0.80
Soft Area:	<u>2,381</u>	<u>sq.m</u>	<u>0.20</u>
Total Catchment Area:	16,386	sq.m	0.74
Time of Concentration:	10	min	
Rainfall Intensity (i):	104	mm/hr	
5-Year Pre-Development Flow Rate (2.78AiC):	350.73	L/s	

MAXIMUM ALLOWABLE RELEASE RATE

Area (A):	16,386	sq.m
Time of Concentration:	10	min
Rainfall Intensity (i):	77	mm/hr (2-Year Event)
Runoff Coefficient (C):	0.50	
Maximum Allowable Release Rate (2.78AiC):	174.94	L/s

100-YEAR EVENT

DRAINAGE AREA I (Uncontrolled Flow Off Site)

(100-YEAR EVENT)

			C
Roof Area:	0	sq.m	1.00
Hard Area:	488	sq.m	1.00
Gravel Area:	0	sq.m	1.00
Soft Area:	<u>833</u>	<u>sq.m</u>	<u>0.25</u>
Total Catchment Area:	1,321	sq.m	0.53
Area (A):	1,321	sq.m	
Time of Concentration:	10	min	
Rainfall Intensity (i):	179	mm/hr	
Runoff Coefficient (C):	0.53		
Flow Rate (2.78AiC):	34.56	L/s	

DRAINAGE AREA II (Proposed Building Roof)

(100-YEAR EVENT)

Total Catchment Area:	2,250	sq.m	C	1.00
No. of Roof Drains:	6			
Slots per Wier:	1	0.01242 L/s/mm/slot (5 USgpm/in/slot)		
Depth at Roof Drains:	144	mm		
Maximum Release Rate:	10.73	L/s	Pond Area:	1,830 sq.m
			Maximum Volume Stored:	87.83 cu.m
			Maximum Volume Required:	87.83 cu.m

Time (min)	i (mm/hr)	2.78AiC (L/s)	Release Rate (L/s)	Stored Rate (L/s)	Required Storage Volume (cu.m)
10	179	111.69	10.73	100.96	60.58
15	143	89.38	10.73	78.65	70.79
20	120	75.03	10.73	64.30	77.16
25	104	64.96	10.73	54.23	81.34
30	92	57.46	10.73	46.74	84.12
35	83	51.65	10.73	40.92	85.94
40	75	47.00	10.73	36.28	87.06
45	69	43.19	10.73	32.46	87.65
50	64	40.00	10.73	29.28	87.83
55	60	37.29	10.73	26.57	87.67
60	56	34.96	10.73	24.23	87.24
65	53	32.93	10.73	22.20	86.59
70	50	31.14	10.73	20.42	85.75
75	47	29.56	10.73	18.83	84.74
80	45	28.14	10.73	17.41	83.59
85	43	26.87	10.73	16.14	82.31
90	41	25.71	10.73	14.99	80.93
95	39	24.67	10.73	13.94	79.45
100	38	23.71	10.73	12.98	77.88
105	36	22.83	10.73	12.10	76.24
110	35	22.02	10.73	11.29	74.52
115	34	21.27	10.73	10.54	72.74
120	33	20.58	10.73	9.85	70.90
125	32	19.93	10.73	9.20	69.01
130	31	19.33	10.73	8.60	67.07
135	30	18.76	10.73	8.04	65.08
140	29	18.23	10.73	7.51	63.06
145	28	17.74	10.73	7.01	60.99
150	28	17.27	10.73	6.54	58.88
180	24	14.95	10.73	4.22	45.61
210	21	13.23	10.73	2.50	31.47
240	19	11.89	10.73	1.16	16.71
270	17	10.82	10.73	0.09	1.45
300	16	9.94	9.94	0.00	0.00

DRAINAGE AREA III (Future Building Roof)

(100-YEAR EVENT)

Total Catchment Area:	910	sq.m	C	1.00
No. of Roof Drains:	3			
Slots per Wier:	1	0.01242 L/s/mm/slot (5 USgpm/in/slot)		
Depth at Roof Drains:	137	mm		
Maximum Release Rate:	5.11	L/s	Pond Area:	730 sq.m
			Maximum Volume Stored:	33.37 cu.m
			Maximum Volume Required:	33.37 cu.m

Time (min)	i (mm/hr)	2.78AiC (L/s)	Release Rate (L/s)	Stored Rate (L/s)	Required Storage Volume (cu.m)
10	179	45.17	5.11	40.06	24.04
15	143	36.15	5.11	31.04	27.94
20	120	30.35	5.11	25.24	30.28
25	104	26.27	5.11	21.16	31.74
30	92	23.24	5.11	18.13	32.64
35	83	20.89	5.11	15.78	33.14
40	75	19.01	5.11	13.90	33.36
45	69	17.47	5.11	12.36	33.37
50	64	16.18	5.11	11.07	33.21
55	60	15.08	5.11	9.98	32.92
60	56	14.14	5.11	9.03	32.51
65	53	13.32	5.11	8.21	32.02
70	50	12.60	5.11	7.49	31.45
75	47	11.95	5.11	6.85	30.81
80	45	11.38	5.11	6.27	30.11
85	43	10.87	5.11	5.76	29.37
90	41	10.40	5.11	5.29	28.57
95	39	9.98	5.11	4.87	27.75
100	38	9.59	5.11	4.48	26.88
105	36	9.23	5.11	4.12	25.98
110	35	8.91	5.11	3.80	25.06
115	34	8.60	5.11	3.49	24.11
120	33	8.32	5.11	3.21	23.13
125	32	8.06	5.11	2.95	22.14
130	31	7.82	5.11	2.71	21.12
135	30	7.59	5.11	2.48	20.09
140	29	7.37	5.11	2.27	19.04
145	28	7.17	5.11	2.07	17.97
150	28	6.98	5.11	1.88	16.89
180	24	6.05	5.11	0.94	10.13
210	21	5.35	5.11	0.24	3.03
240	19	4.81	4.81	0.00	0.00
270	17	4.38	4.38	0.00	0.00
300	16	4.02	4.02	0.00	0.00

DRAINAGE AREA IV (North Area)

(100-YEAR EVENT)

			C
Roof Area:	138	sq.m	1.00
Hard Area:	3,005	sq.m	1.00
Gravel Area:	3,517	sq.m	1.00
Soft Area:	123	sq.m	0.25

Total Catchment Area: 6,783 sq.m 0.99

Water Elevation: 68.73 m

Head: 1.93 m

Centroid of ICD Orifice: 66.80 m
(ICD in Outlet Pipe of CB/MH-13)

Invert of Outlet Pipe of CB/MH-13: 66.73 m

Orifice Diameter: 134 mm

Orifice Area: 14,201 sq.mm

Discharge Coefficient: 0.61

Maximum Release Rate: 53.32 L/s

CB/MH	Top Area (sq.m)	Depth (m)	Volume	
CB-4	179	0.20	11.84	cu.m
CB/MH-5	288	0.20	19.02	cu.m
CB-6	219	0.20	14.43	cu.m
CB-7	593	0.20	39.15	cu.m
CB-8	312	0.20	20.58	cu.m
CB/MH-9	283	0.20	18.70	cu.m
CB-10	71	0.11	2.57	cu.m
CB/MH-11	80	0.13	3.43	cu.m

CB/MH Storage			
CB/MH	Invert	Size	Volume
CB-4	67.04	0.61	0.63
CB/MH-5	67.07	1.219	1.94
CB-6	67.02	0.61	0.64
CB-7	66.96	0.61	0.66
CB-8	66.89	0.61	0.68
CB/MH-9	66.99	1.219	2.03
CB-10	66.77	0.61	0.73
CB/MH-11	66.80	1.219	2.25
CB/MH-12	66.80	1.524	3.52
CB/MH-13	66.73	1.524	3.64

DRAINAGE AREA IV (Continued)

(100-YEAR EVENT)

Pipe Storage						
From	Invert	To	Invert	Length	Dia.	Volume
CB-4	67.04	pipe	67.03	1.5	0.45	0.24
CB/MH-5	67.07	CB/MH-9	66.99	36.4	0.45	5.79
CB-6	67.02	pipe	66.98	16.5	0.45	2.62
CB-7	66.96	pipe	66.93	14.4	0.45	2.29
CB-8	66.89	pipe	66.86	9.8	0.45	1.56
CB/MH-9	66.99	CB/MH-11	66.80	93.0	0.45	14.79
CB-10	66.77	pipe	66.76	3.1	0.45	0.49
CB/MH-11	66.80	CB/MH-13	66.73	36.6	0.45	5.82
CB/MH-12	66.80	CB/MH-13	66.80	8.2	0.60	2.32

Chamber Storage HS180

No. of Chambers	Volume Per Chamber	No. of Rows	No. of End Caps	Volume Per End Cap	Volume
18	3.22	2	4	0.43	59.68 cu.m

Clear Stone Storage

Length	Width	Depth	Volume	40% Voids
21.225	4.852	1.46	90.68	36.27 cu.m

Maximum Volume Stored: 278.31 cu.m

Maximum Volume Required: 278.31 cu.m

DRAINAGE AREA IV (Continued)

(100-YEAR EVENT)

Time (min)	i (mm/hr)	2.78AiC (L/s)	ICD Release Rate (L/s)	Stored Rate (L/s)	Required Storage Volume (cu.m)
10	179	332.12	26.66	305.47	183.28
15	143	265.79	26.66	239.13	215.22
20	120	223.11	26.66	196.45	235.74
25	104	193.16	26.66	166.50	249.75
30	92	170.88	26.66	144.22	259.60
35	83	153.60	26.66	126.94	266.58
40	75	139.77	26.66	113.11	271.47
45	69	128.44	26.66	101.78	274.80
50	64	118.96	26.66	92.30	276.90
55	60	110.90	26.66	84.24	278.01
60	56	103.97	26.66	77.31	278.31
75	47	87.90	26.66	61.24	275.57
90	41	76.47	26.66	49.81	268.97
105	36	67.89	26.66	41.23	259.74
120	33	61.19	26.66	34.53	248.60
135	30	55.80	26.66	29.14	236.01
150	28	51.36	26.66	24.70	222.29
165	26	47.63	26.66	20.97	207.65
180	24	44.46	26.66	17.80	192.26
195	22	41.72	26.66	15.06	176.23
210	21	39.33	26.66	12.67	159.66
240	19	35.35	26.66	8.69	125.18
270	17	32.17	26.66	5.51	89.27
300	16	29.56	26.66	2.90	52.21
330	15	27.38	26.66	0.72	14.23
360	14	25.52	25.52	0.00	0.00
390	13	23.93	23.93	0.00	0.00

DRAINAGE AREA V (South Area)

(100-YEAR EVENT)

			C
Roof Area:	0	sq.m	1.00
Hard Area:	2,329	sq.m	1.00
Gravel Area:	2,460	sq.m	1.00
Soft Area:	333	sq.m	0.25

Total Catchment Area: 5,122 sq.m 0.95

Water Elevation: 69.02 m

Head: 2.18 m

Centroid of ICD Orifice: 66.84 m
(ICD in Outlet Pipe of CB/MH-23)

Invert of Outlet Pipe of CB/MH-23: 66.76 m

Orifice Diameter: 151 mm

Orifice Area: 17,835 sq.mm

Discharge Coefficient: 0.61

Maximum Release Rate: 71.23 L/s

CB/MH	Top Area (sq.m)	Depth (m)	Volume	
CB-14	125	0.14	5.83	cu.m
CB/MH-15	113	0.12	4.52	cu.m
CB-16	119	0.12	4.76	cu.m
CB/MH-17	89	0.12	3.56	cu.m
CB/MH-18	292	0.20	19.47	cu.m
CB/MH-19	204	0.20	13.60	cu.m
CB-20	102	0.15	5.10	cu.m
CB/MH-22	100	0.15	5.00	cu.m
CB/MH-23	68	0.09	2.04	cu.m

Stormwater detention area

CB-20 183 0.51 46.21 cu.m

Maximum Volume Stored: 110.09 cu.m

Maximum Volume Required: 110.09 cu.m

DRAINAGE AREA V (Continued)

(100-YEAR EVENT)

Time (min)	i (mm/hr)	2.78AiC (L/s)	ICD Release Rate (L/s)	Stored Rate (L/s)	Required Storage Volume (cu.m)
10	179	241.86	71.23	170.63	102.38
15	143	193.55	71.23	122.32	110.09
20	120	162.47	71.23	91.24	109.49
25	104	140.66	71.23	69.43	104.15
30	92	124.43	71.23	53.21	95.77
35	83	111.85	71.23	40.63	85.31
40	75	101.78	71.23	30.56	73.34
45	69	93.53	71.23	22.30	60.21
50	64	86.62	71.23	15.40	46.20
55	60	80.76	71.23	9.53	31.46
60	56	75.71	71.23	4.48	16.14
65	53	71.31	71.23	0.08	0.32
70	50	67.44	67.44	0.00	0.00
75	47	64.01	64.01	0.00	0.00
80	45	60.94	60.94	0.00	0.00
85	43	58.18	58.18	0.00	0.00
90	41	55.68	55.68	0.00	0.00
95	39	53.41	53.41	0.00	0.00
100	38	51.34	51.34	0.00	0.00
105	36	49.44	49.44	0.00	0.00
110	35	47.68	47.68	0.00	0.00
115	34	46.06	46.06	0.00	0.00
120	33	44.56	44.56	0.00	0.00
125	32	43.16	43.16	0.00	0.00
130	31	41.85	41.85	0.00	0.00
135	30	40.63	40.63	0.00	0.00
140	29	39.49	39.49	0.00	0.00
145	28	38.41	38.41	0.00	0.00
150	28	37.40	37.40	0.00	0.00
180	24	32.38	32.38	0.00	0.00
210	21	28.64	28.64	0.00	0.00
240	19	25.74	25.74	0.00	0.00
270	17	23.43	23.43	0.00	0.00
300	16	21.52	21.52	0.00	0.00
330	15	19.94	19.94	0.00	0.00
360	14	18.59	18.59	0.00	0.00
390	13	17.42	17.42	0.00	0.00

5-YEAR EVENT

DRAINAGE AREA I (Uncontrolled Flow Off Site)

(5-YEAR EVENT)

			C
Roof Area:	0	sq.m	0.90
Hard Area:	488	sq.m	0.90
Gravel Area:	0	sq.m	0.80
Soft Area:	<u>833</u>	<u>sq.m</u>	<u>0.20</u>
Total Catchment Area:	1,321	sq.m	0.46
Area (A):	1,321	sq.m	
Time of Concentration:	10	min	
Rainfall Intensity (i):	104	mm/hr	
Runoff Coefficient (C):	0.46		
Flow Rate (2.78AiC):	17.55	L/s	

DRAINAGE AREA II (Proposed Building Roof)

(5-YEAR EVENT)

Total Catchment Area:	2,250	sq.m	C	0.90
No. of Roof Drains:	6			
Slots per Wier:	1	0.01242 L/s/mm/slot (5 USgpm/in/slot)		
Depth at Roof Drains:	111	mm		
Maximum Release Rate:	8.26	L/s	Pond Area:	1,084 sq.m
			Maximum Volume Stored:	40.02 cu.m
			Maximum Volume Required:	40.02 cu.m

Time (min)	i (mm/hr)	2.78AiC (L/s)	Release Rate (L/s)	Stored Rate (L/s)	Required Storage Volume (cu.m)
10	104	58.66	8.26	50.40	30.24
15	84	47.04	8.26	38.78	34.90
20	70	39.55	8.26	31.29	37.55
25	61	34.28	8.26	26.03	39.04
30	54	30.36	8.26	22.10	39.79
35	49	27.31	8.26	19.06	40.02
40	44	24.87	8.26	16.62	39.88
45	41	22.87	8.26	14.62	39.46
50	38	21.20	8.26	12.94	38.82
55	35	19.77	8.26	11.52	38.01
60	33	18.55	8.26	10.29	37.04
65	31	17.48	8.26	9.22	35.96
70	29	16.53	8.26	8.28	34.77
75	28	15.70	8.26	7.44	33.50
80	27	14.95	8.26	6.70	32.15
85	25	14.28	8.26	6.03	30.73
90	24	13.67	8.26	5.42	29.26
95	23	13.12	8.26	4.86	27.73
100	22	12.61	8.26	4.36	26.15
105	22	12.15	8.26	3.89	24.54
110	21	11.72	8.26	3.47	22.88
115	20	11.33	8.26	3.07	21.19
120	19	10.96	8.26	2.70	19.47
125	19	10.62	8.26	2.36	17.72
130	18	10.30	8.26	2.04	15.94
135	18	10.00	8.26	1.75	14.14
140	17	9.72	8.26	1.47	12.31
145	17	9.46	8.26	1.20	10.47
150	16	9.21	8.26	0.96	8.60
180	14	7.98	7.98	0.00	0.00
210	13	7.07	7.07	0.00	0.00
240	11	6.36	6.36	0.00	0.00
270	10	5.79	5.79	0.00	0.00
300	9	5.32	5.32	0.00	0.00

DRAINAGE AREA III (Future Building Roof)

(5-YEAR EVENT)

Total Catchment Area:	910	sq.m	C	0.90
No. of Roof Drains:	3			
Slots per Wier:	1	0.01242 L/s/mm/slot (5 USgpm/in/slot)		
Depth at Roof Drains:	105	mm		
Maximum Release Rate:	3.92	L/s	Pond Area:	429 sq.m
			Maximum Volume Stored:	15.05 cu.m
			Maximum Volume Required:	15.05 cu.m

Time (min)	i (mm/hr)	2.78AiC (L/s)	Release Rate (L/s)	Stored Rate (L/s)	Required Storage Volume (cu.m)
10	104	23.72	3.92	19.81	11.88
15	84	19.02	3.92	15.11	13.60
20	70	15.99	3.92	12.08	14.49
25	61	13.86	3.92	9.95	14.92
30	54	12.28	3.92	8.36	15.05
35	49	11.05	3.92	7.13	14.97
40	44	10.06	3.92	6.14	14.74
45	41	9.25	3.92	5.33	14.40
50	38	8.57	3.92	4.66	13.97
55	35	8.00	3.92	4.08	13.46
60	33	7.50	3.92	3.58	12.90
65	31	7.07	3.92	3.15	12.29
70	29	6.69	3.92	2.77	11.63
75	28	6.35	3.92	2.43	10.94
80	27	6.05	3.92	2.13	10.22
85	25	5.78	3.92	1.86	9.48
90	24	5.53	3.92	1.61	8.71
95	23	5.31	3.92	1.39	7.92
100	22	5.10	3.92	1.18	7.11
105	22	4.91	3.92	1.00	6.28
110	21	4.74	3.92	0.82	5.43
115	20	4.58	3.92	0.66	4.58
120	19	4.43	3.92	0.51	3.71
125	19	4.29	3.92	0.38	2.83
130	18	4.17	3.92	0.25	1.93
135	18	4.04	3.92	0.13	1.03
140	17	3.93	3.92	0.01	0.12
145	17	3.83	3.83	0.00	0.00
150	16	3.73	3.73	0.00	0.00
180	14	3.23	3.23	0.00	0.00
210	13	2.86	2.86	0.00	0.00
240	11	2.57	2.57	0.00	0.00
270	10	2.34	2.34	0.00	0.00
300	9	2.15	2.15	0.00	0.00

DRAINAGE AREA IV (North Area)

(5-YEAR EVENT)

			C
Roof Area:	138	sq.m	0.90
Hard Area:	3,005	sq.m	0.90
Gravel Area:	3,517	sq.m	0.80
Soft Area:	<u>123</u>	<u>sq.m</u>	<u>0.20</u>
Total Catchment Area:	6,783	sq.m	0.84
Water Elevation:	67.81	m	
Head:	1.02	m	
Centroid of ICD Orifice: (ICD in Outlet Pipe of CB/MH-13)	66.80	m	
Invert of Outlet Pipe of CB/MH-13:	66.73	m	
Orifice Diameter:	134	mm	
Orifice Area:	14,201	sq.mm	
Discharge Coefficient:	0.61		
Maximum Release Rate:	38.66	L/s	

CB/MH	Top Area (sq.m)	Depth (m)	Volume	
CB-4	2,356	0.00	0.00	cu.m
CB/MH-5	3,785	0.00	0.00	cu.m
CB-6	2,871	0.00	0.00	cu.m
CB-7	7,789	0.00	0.00	cu.m
CB-8	4,094	0.00	0.00	cu.m
CB/MH-9	3,721	0.00	0.00	cu.m
CB-10	3,989	0.00	0.00	cu.m
CB/MH-11	3,047	0.00	0.00	cu.m

CB/MH Storage			
CB/MH	Invert	Size	Volume
CB-4	67.04	0.61	0.29
CB/MH-5	67.07	1.219	0.87
CB-6	67.02	0.61	0.29
CB-7	66.96	0.61	0.32
CB-8	66.89	0.61	0.34
CB/MH-9	66.99	1.219	0.96
CB-10	66.77	0.61	0.39
CB/MH-11	66.80	1.219	1.18
CB/MH-12	66.80	1.524	1.85
CB/MH-13	66.73	1.524	1.97

Pipe Storage						
From	Invert	To	Invert	Length	Dia.	Volume
CB-4	67.0	pipe	67.0	1.5	0.45	0.24
CB/MH-5	67.1	CB/MH-9	67.0	36.4	0.45	5.79
CB-6	67.0	pipe	67.0	16.5	0.45	2.62
CB-7	67.0	pipe	66.9	14.4	0.45	2.29
CB-8	66.9	pipe	66.9	9.8	0.45	1.56
CB/MH-9	67.0	CB/MH-11	66.8	93.0	0.45	14.79
CB-10	66.8	pipe	66.8	3.1	0.45	0.49
CB/MH-11	66.8	CB/MH-13	66.7	36.6	0.45	5.82
CB/MH-12	66.8	CB/MH-13	66.8	8.2	0.60	2.32

Chamber Storage HS180

No. of Chambers	Volume Per Chamber	No. of Rows	No. of End Caps	Volume Per End Cap	Volume
18	3.11	2	4	0.43	57.63 cu.m

Clear Stone Storage

Length	Width	Depth	Volume	40% Voids
21.225	4.852	1.01	46.62	18.65 cu.m

Maximum Volume Stored: 120.67 cu.m

Maximum Volume Required: 120.67 cu.m

DRAINAGE AREA IV (Continued)

(5-YEAR EVENT)

Time (min)	i (mm/hr)	2.78AiC (L/s)	ICD Release Rate (L/s)	Stored Rate (L/s)	Required Storage Volume (cu.m)
10	104	164.15	19.33	144.82	86.89
15	84	131.64	19.33	112.31	101.08
20	70	110.67	19.33	91.34	109.61
25	61	95.94	19.33	76.61	114.91
30	54	84.96	19.33	65.63	118.13
35	49	76.43	19.33	57.10	119.92
40	44	69.61	19.33	50.28	120.67
45	41	64.01	19.33	44.68	120.63
50	38	59.32	19.33	39.99	119.97
55	35	55.33	19.33	36.00	118.81
60	33	51.90	19.33	32.57	117.25
75	28	43.94	19.33	24.61	110.73
90	24	38.26	19.33	18.93	102.24
105	22	34.00	19.33	14.67	92.43
120	19	30.67	19.33	11.34	81.64
135	18	27.99	19.33	8.66	70.12
150	16	25.78	19.33	6.45	58.02
165	15	23.92	19.33	4.59	45.46
180	14	22.34	19.33	3.01	32.50
195	13	20.97	19.33	1.64	19.23
210	13	19.78	19.33	0.45	5.67
240	11	17.79	17.79	0.00	0.00
270	10	16.20	16.20	0.00	0.00
300	9	14.90	14.90	0.00	0.00
330	9	13.81	13.81	0.00	0.00
360	8	12.88	12.88	0.00	0.00
390	8	12.08	12.08	0.00	0.00

DRAINAGE AREA V (South Area)

(5-YEAR EVENT)

			C
Roof Area:	0	sq.m	0.90
Hard Area:	2,329	sq.m	0.90
Gravel Area:	2,460	sq.m	0.80
Soft Area:	333	sq.m	<u>0.20</u>

Total Catchment Area: 5,122 sq.m 0.81

Water Elevation: 68.90 m

Head: 2.07 m

Centroid of ICD Orifice: 66.84 m
(ICD in Outlet Pipe of CB/MH-23)

Invert of Outlet Pipe of CB/MH-23: 66.76 m

Orifice Diameter: 151 mm

Orifice Area: 17,835 sq.mm

Discharge Coefficient: 0.61

Maximum Release Rate: 69.32 L/s

CB/MH	Top Area (sq.m)	Depth (m)	Volume	
CB-14	4	0.02	0.03	cu.m
CB/MH-15	0	0.00	0.00	cu.m
CB-16	0	0.00	0.00	cu.m
CB/MH-17	0	0.00	0.00	cu.m
CB/MH-18	52	0.08	1.48	cu.m
CB/MH-19	37	0.08	1.03	cu.m
CB-20	5	0.03	0.06	cu.m
CB/MH-22	5	0.03	0.06	cu.m
CB/MH-23	5	0.00	0.00	cu.m

Stormwater detention area

CB-20 141 0.39 27.52 cu.m

Maximum Volume Stored: 30.20 cu.m

Maximum Volume Required: 30.20 cu.m

DRAINAGE AREA V (Continued)

(5-YEAR EVENT)

Time (min)	i (mm/hr)	2.78AiC (L/s)	ICD Release Rate (L/s)	Stored Rate (L/s)	Required Storage Volume (cu.m)
10	104	119.65	69.32	50.33	30.20
15	84	95.95	69.32	26.63	23.97
20	70	80.67	69.32	11.35	13.62
25	61	69.93	69.32	0.61	0.91
30	54	61.93	61.93	0.00	0.00
35	49	55.71	55.71	0.00	0.00
40	44	50.74	50.74	0.00	0.00
45	41	46.66	46.66	0.00	0.00
50	38	43.24	43.24	0.00	0.00
55	35	40.33	40.33	0.00	0.00
60	33	37.83	37.83	0.00	0.00
65	31	35.65	35.65	0.00	0.00
70	29	33.73	33.73	0.00	0.00
75	28	32.03	32.03	0.00	0.00
80	27	30.50	30.50	0.00	0.00
85	25	29.13	29.13	0.00	0.00
90	24	27.89	27.89	0.00	0.00
95	23	26.76	26.76	0.00	0.00
100	22	25.73	25.73	0.00	0.00
105	22	24.78	24.78	0.00	0.00
110	21	23.91	23.91	0.00	0.00
115	20	23.10	23.10	0.00	0.00
120	19	22.36	22.36	0.00	0.00
125	19	21.66	21.66	0.00	0.00
130	18	21.01	21.01	0.00	0.00
135	18	20.40	20.40	0.00	0.00
140	17	19.83	19.83	0.00	0.00
145	17	19.29	19.29	0.00	0.00
150	16	18.79	18.79	0.00	0.00
180	14	16.28	16.28	0.00	0.00
210	13	14.42	14.42	0.00	0.00

**CDS ESTIMATED NET ANNUAL TSS LOAD REDUCTION
BASED ON THE RATIONAL RAINFALL METHOD
AND A FINE PARTICLE SIZE DISTRIBUTION**



Echelon Environmental

55 Albert Street, Suite #200 | Markham, ON, L3P 2T4

www.echelonenvironmental.ca

info@echelonenvironmental.ca

[905-948-0000](tel:905-948-0000)

Project Name: 1547 Lagan Way
Location: Ottawa, ON
OGS ID: OGS

Engineer: D.B. Gray Engineering Inc.
Contact: Laurent Bosseau
Report Date: 16-Dec-25

Area: 1.732 ha **Rainfall Station #** 215
C Value: 0.77 **Particle Size Distribution** FINE
CDS Model: PMSU3020-6 **CDS Treatment Capacity:** 57 l/s

<u>Rainfall Intensity¹</u> <u>(mm/hr)</u>	<u>Percent Rainfall Volume¹</u>	<u>Cumulative Rainfall Volume</u>	<u>Total Flowrate (l/s)</u>	<u>Treated Flowrate (l/s)</u>	<u>Operating Rate (%)</u>	<u>Removal Efficiency (%)</u>	<u>Incremental Removal (%)</u>
0.5	9.2%	9.2%	1.9	1.9	3.3	97.9	9.0
1.0	10.6%	19.8%	3.7	3.7	6.5	97.0	10.3
1.5	9.9%	29.7%	5.6	5.6	9.8	96.0	9.5
2.0	8.4%	38.1%	7.4	7.4	13.1	95.1	8.0
2.5	7.7%	45.8%	9.3	9.3	16.4	94.2	7.2
3.0	5.9%	51.7%	11.1	11.1	19.6	93.2	5.5
3.5	4.4%	56.1%	13.0	13.0	22.9	92.3	4.0
4.0	4.7%	60.7%	14.8	14.8	26.2	91.4	4.3
4.5	3.3%	64.0%	16.7	16.7	29.5	90.4	3.0
5.0	3.0%	67.1%	18.5	18.5	32.7	89.5	2.7
6.0	5.4%	72.4%	22.2	22.2	39.3	87.6	4.7
7.0	4.4%	76.8%	26.0	26.0	45.8	85.7	3.7
8.0	3.5%	80.3%	29.7	29.7	52.4	83.8	3.0
9.0	2.8%	83.2%	33.4	33.4	58.9	82.0	2.3
10.0	2.2%	85.3%	37.1	37.1	65.5	80.1	1.7
15.0	7.0%	92.3%	55.6	55.6	98.2	70.7	4.9
20.0	4.5%	96.9%	74.2	56.6	100.0	53.6	2.4
25.0	1.4%	98.3%	92.7	56.6	100.0	42.9	0.6
30.0	0.7%	99.0%	111.2	56.6	100.0	35.7	0.2
35.0	0.5%	99.5%	129.8	56.6	100.0	30.6	0.1
40.0	0.5%	100.0%	148.3	56.6	100.0	26.8	0.1
45.0	0.0%	100.0%	166.9	56.6	100.0	23.8	0.0
50.0	0.0%	100.0%	185.4	56.6	100.0	21.4	0.0

Removal Efficiency Adjustment² = 6.5%
Predicted Net Annual TSS Removal Efficiency = 81.0%
Predicted Annual Rainfall Treated = 97.0%

- 1 - Based on 42 years of hourly rainfall data from Canadian Station 6105976, Ottawa ON
- 2 - Reduction due to use of 60-minute data for a site that has a time of concentration less than 30-minutes.
- 3 - CDS Efficiency based on testing conducted at the University of Central Florida
- 4 - CDS design flowrate and scaling based on standard manufacturer model & product specifications

CDS PMSU-3020-6-C DESIGN NOTES

THE STANDARD CDS PMSU-3020-6-C CONFIGURATION IS SHOWN.
 ANTI-BUOYANCY SLAB MAY BE INCLUDED (NOT SHOWN).
 SUMP DEPTH SHOWN IS TYPICAL, CAN BE EXTENDED AS REQUIRED.
 HYDRAULIC CHARACTERISTICS VARY BASED ON PIPE SIZE, MATERIAL, AND CDS UNIT SELECTION. FOR CUSTOM HYDRAULIC ANALYSIS PLEASE CONTACT ECHELON ENVIRONMENTAL.
 FOR SITE SPECIFIC DRAWINGS PLEASE CONTACT ECHELON ENVIRONMENTAL.

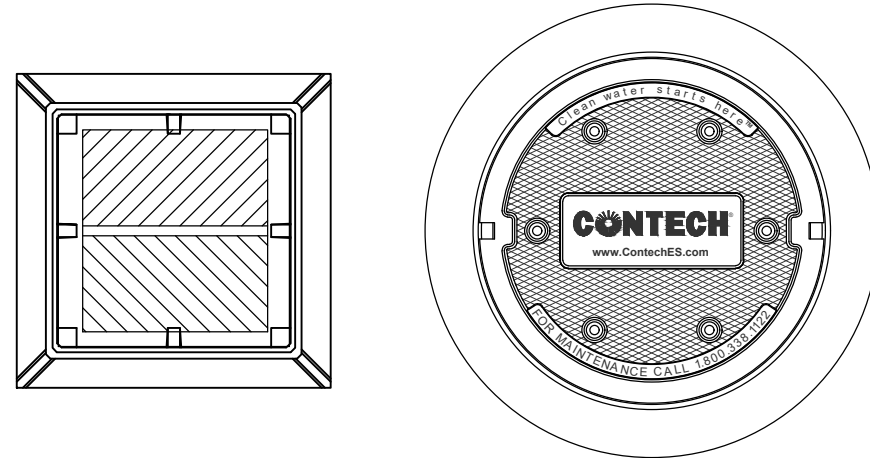
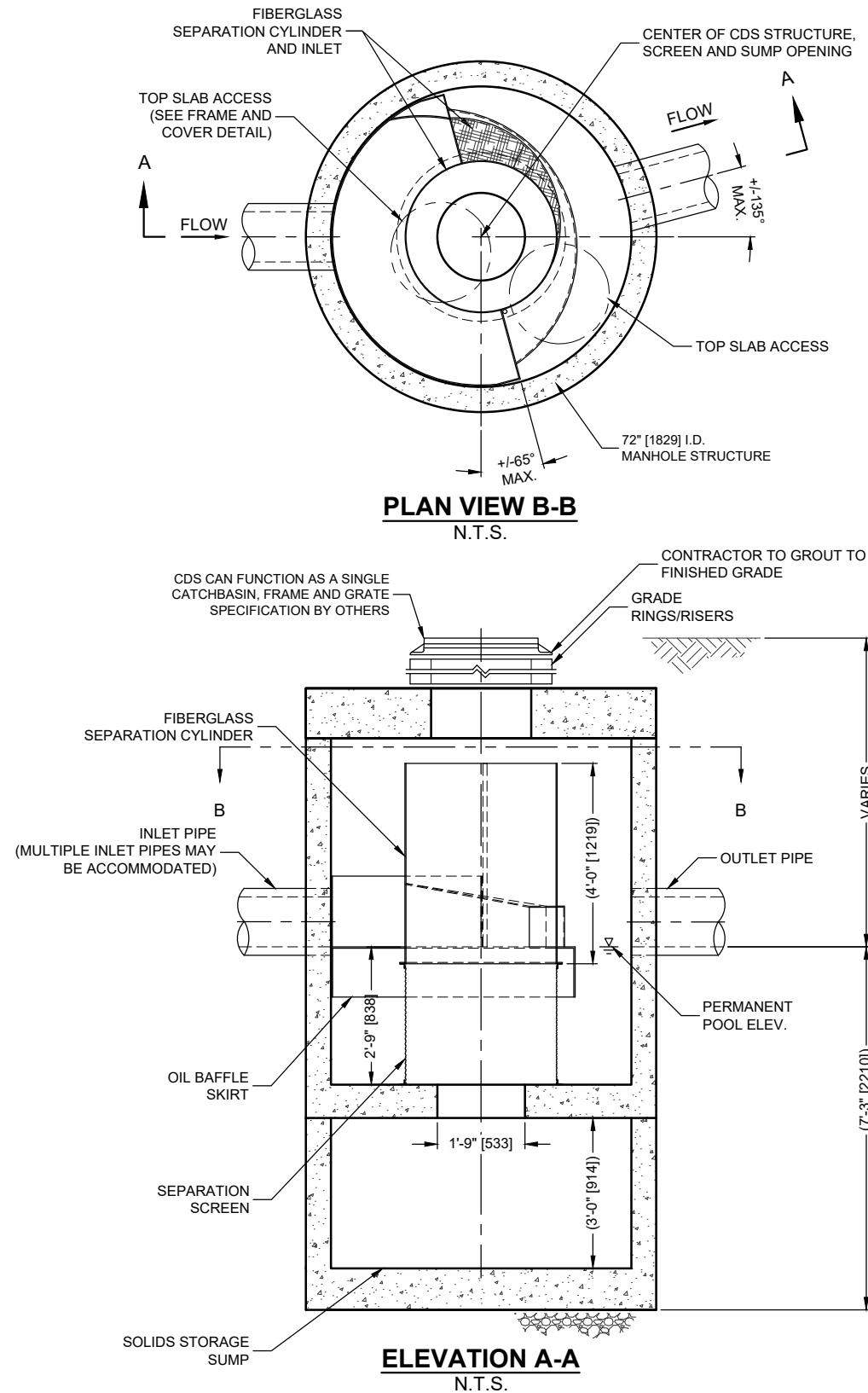

FRAME AND GRATE
(DIMENSIONS VARIES)
N.T.S.

FRAME AND COVER
(DIAMETER VARIES)
N.T.S.

GENERAL NOTES

1. CONTECH TO PROVIDE ALL MATERIALS UNLESS NOTED OTHERWISE.
2. DIMENSIONS MARKED WITH () ARE REFERENCE DIMENSIONS. ACTUAL DIMENSIONS MAY VARY.
3. FOR FABRICATION DRAWINGS WITH DETAILED STRUCTURE DIMENSIONS AND WEIGHTS, PLEASE CONTACT YOUR CONTECH ENGINEERED SOLUTIONS LLC REPRESENTATIVE. www.ContechES.com
4. CDS WATER QUALITY STRUCTURE SHALL BE IN ACCORDANCE WITH ALL DESIGN DATA AND INFORMATION CONTAINED IN THIS DRAWING.
5. STRUCTURE SHALL MEET AASHTO HS20 LOAD RATING, ASSUMING GROUNDWATER ELEVATION AT, OR BELOW, THE OUTLET PIPE INVERT ELEVATION. ENGINEER OF RECORD TO CONFIRM ACTUAL GROUNDWATER ELEVATION. CASTINGS SHALL MEET HS20 (AASHTO M 306) AND BE CAST WITH THE CONTECH LOGO.
6. IF REQUIRED, PVC HYDRAULIC SHEAR PLATE IS PLACED ON SHELF AT BOTTOM OF SCREEN CYLINDER. REMOVE AND REPLACE AS NECESSARY DURING MAINTENANCE CLEANING.

INSTALLATION NOTES

- A. ANY SUB-BASE, BACKFILL DEPTH, AND/OR ANTI-FLOTATION PROVISIONS ARE SITE-SPECIFIC DESIGN CONSIDERATIONS AND SHALL BE SPECIFIED BY ENGINEER OF RECORD.
- B. CONTRACTOR TO PROVIDE EQUIPMENT WITH SUFFICIENT LIFTING AND REACH CAPACITY TO LIFT AND SET THE CDS MANHOLE STRUCTURE (LIFTING CLUTCHES PROVIDED).
- C. CONTRACTOR TO ADD JOINT SEALANT BETWEEN ALL STRUCTURE SECTIONS, AND ASSEMBLE STRUCTURE.
- D. CONTRACTOR TO PROVIDE, INSTALL, AND GROUT PIPES. MATCH PIPE INVERTS WITH ELEVATIONS SHOWN.
- E. CONTRACTOR TO TAKE APPROPRIATE MEASURES TO ASSURE UNIT IS WATER TIGHT, HOLDING WATER TO FLOWLINE INVERT MINIMUM. IT IS SUGGESTED THAT ALL JOINTS BELOW PIPE INVERTS ARE GROUTED.

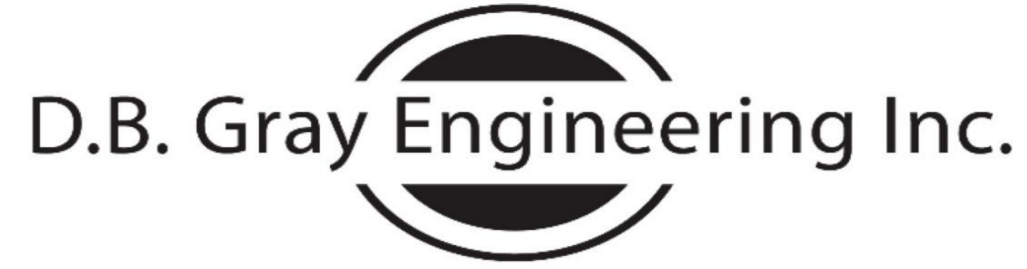

STORM SEWER CALCULATIONS

Rational Method

2-YEAR EVENT

Project: 1547 Lagan Way
Ottawa, Ontario

Stormwater Management - Grading & Drainage - Storm & Sanitary Sewers - Watermains

700 Long Point Circle
Ottawa, Ontario K1T 4E9

613-425-8044
d.gray@dbgrayengineering.com

Date: December 16, 2025

Manning's Roughness Coefficient: 0.013

Location		Individual				Cumulative				Sewer Data												
		Roof C = 0.90 (ha)	Hard C = 0.90 (ha)	Gravel C = 0.70 (ha)	Soft C = 0.20 (ha)	2.78AC	2.78AC	Time (min)	Rainfall Intensity (mm/hr)	Q Flow Rate (L/s)	Length (m)	Nominal Diameter (mm)	Actual Diameter (mm)	Slope (%)	Velocity (m/s)	Q _{Full} Capacity (L/s)	Time (min)	Q / Q _{Full}				
From	To																					
CB-1	Prop Bld		0.0275			0.0688	0.0688	10.00	77	5.3	1.4	250	251	2	1.72	85.0	0.0	0.06				
Prop Bld	CB-2	0.2250				0.5630	0.6318	10.01	77	48.5	7.7	300	299	2	1.93	135.5	0.1	0.36				
Flow Control Roof Drains Release Rate:										8.26	7.7	300	299	2	1.93	135.5	0.1	0.06				
CB-2	CB/MH-3		0.0115	0.0005	0.0670	0.0670	0.6988	10.08	76	53.5	16.8	300	299	0.34	0.80	55.9	0.4	0.96				
CB/MH-3	CB/MH-24		0.0033		0.0071	0.0122	0.7110	10.43	75	53.5	63.3	300	299	0.34	0.80	55.9	1.3	0.96				
CB-4	CB/MH-5		0.0394			0.0986	0.0986	10.00	77	7.6	1.5	450	457	0.195	0.80	131.2	0.0	0.06				
CB/MH-5	CB/MH-9		0.0568	0.0012	0.0111	0.1506	0.2492	10.03	77	19.1	36.4	450	457	0.195	0.80	131.2	0.8	0.15				
CB-6	CB/MH-9			0.0291		0.0566	0.0566	10.00	77	4.3	16.5	450	457	0.195	0.80	131.2	0.3	0.03				
CB-7	CB/MH-9		0.0331	0.1473		0.3695	0.3695	10.00	77	28.4	14.4	450	457	0.195	0.80	131.2	0.3	0.22				
CB-8	CB/MH-9		0.0272	0.1464		0.3529	0.3529	10.00	77	27.1	9.8	450	457	0.195	0.80	131.2	0.2	0.21				
CB/MH-9	CB/MH-11		0.0249	0.0214		0.1039	1.1322	10.79	74	83.7	93	450	457	0.195	0.80	131.2	1.9	0.64				
CB-10	CB/MH-11		0.0667			0.1669	0.1669	10.00	77	12.8	3.1	450	457	0.195	0.80	131.2	0.1	0.10				
CB/MH-11	MH-13		0.0276	0.0943		0.2526	1.5516	12.73	68	105.1	36.6	450	457	0.195	0.80	131.2	0.8	0.80				
Future Bld	MH-13		0.0910			0.2277	0.2277	10.00	77	17.5	30.3	200	201	2	1.48	47.0	0.3	0.37				
Flow Control Roof Drains Release Rate:										3.92	30.3	200	201	2	1.48	47.0	0.3	0.08				
MH-13	CB/MH-24					0.0000	1.7793	13.49	66	116.7	10.9	525	533	0.5	1.42	316.6	0.1	0.37				
ICD Release Rate:										38.66	10.9	525	533	0.5	1.42	316.6	0.1	0.12				
CB-14	CB/MH-15		0.0288			0.0721	0.0721	10.00	77	5.5	22.2	250	251	0.43	0.80	39.4	0.5	0.14				
CB/MH-15	CB/MH-17		0.0127	0.0566		0.1419	0.2140	10.46	75	16.1	18.3	250	251	0.43	0.80	39.4	0.4	0.41				
CB-16	CB/MH-17		0.0281	0.0877		0.2410	0.2410	10.00	77	18.5	6.2	250	251	0.43	0.80	39.4	0.1	0.47				
CB/MH-17	CB/MH-18		0.0204	0.0598		0.1674	0.6224	10.85	74	45.9	43.2	300	299	0.34	0.80	55.9	0.9	0.82				
CB/MH-18	CB/MH-19		0.0443	0.0729		0.2527	0.8751	11.75	71	61.8	20	300	299	0.34	0.80	55.9	0.4	1.11				
CB/MH-19	CB/MH-23		0.0312			0.0781	0.9531	12.17	69	66.1	12.7	300	299	0.34	0.80	55.9	0.3	1.18				
CB-20	CB/MH-22		0.0439		0.0027	0.1113	0.1113	10.00	77	8.6	15.1	250	251	0.43	0.80	39.4	0.3	0.22				
CB-21	CB/MH-22			0.0056	0.0300	0.0276	0.0276	10.00	77	2.1	4.8	250	251	0.43	0.80	39.4	0.1	0.05				
CB/MH-22	CB/MH-23		0.0165			0.0413	0.1802	10.32	76	13.6	12.9	250	251	0.43	0.80	39.4	0.3	0.35				
CB/MH-23	CB/MH-24		0.0070			0.0175	1.1508	12.44	69	78.9	16.6	525	533	0.2	0.90	200.2	0.3	0.39				
ICD Release Rate:										69.32	16.6	525	533	0.2	0.90	200.2	0.3	0.35				
CB/MH-24	MH-25		0.0184	0.0008	0.0054	0.0506	3.6917	13.62	65	240.8	4.3	525	533	0.3	1.10	245.2	0.1	0.98				
MH-25	EXIST. 600 ST					0.0000	3.6917	13.68	65	240.2	10	525	533	0.3	1.10	245.2	0.2	0.98				
CB-27	EXIST. 750 ST		0.0099	0.0022	0.0030	0.0307	0.0307	10.00	77	2.4	23.8	250	251	1	1.21	60.1	0.3	0.04				
		0.2250	0.6603	0.7236	0.1233	Existing 600 mm Municipal Storm Sewer:										600	610	0.36	1.32	385.0		
		Existing 750 mm Municipal Storm Sewer:										750	762	0.41	1.63	743.7						