

Engineering

Land/Site
Development

Municipal
Infrastructure

Environmental/
Water Resources

Traffic/
Transportation

Recreational

Planning

Land/Site
Development

Planning Application
Management

Municipal Planning

Urban Design

Expert Witness
(OLT)

Wireless Industry

Landscape Architecture

Streetscapes &
Public Amenities

Open Space, Parks &
Recreation

Community &
Residential

Commercial &
Institutional

Environmental
Restoration

Willow Court 3400 Woodroffe Avenue

Servicing Design Brief

**SERVICING DESIGN BRIEF
WILLOW COURT
3400 WOODROFFE AVENUE**



Prepared By:

NOVATECH

Suite 200, 240 Michael Cowpland Drive
Ottawa, Ontario
K2M 1P6

November 5, 2025
Revised: April 14, 2026

Novatech File: 124147
Ref: R-2025-80

April 14, 2026

Fotenn
420 O'Connor Street
Ottawa, ON K2P 1W4

Attention: Tamara Nahal, Planner

**Reference: Willow Court
3400 Woodroffe Avenue
Servicing Design Brief
Our File No.: 124147**

Enclosed for City review and approval is the Servicing Design Brief for the proposed 3400 Woodroffe Avenue development.

If you have any questions or comments, please do not hesitate to contact us.

Sincerely,

NOVATECH



Lucas Wilson, P.Eng.
Project Engineer

TABLE OF CONTENTS

1.0	INTRODUCTION	3
2.0	ROADWAYS	5
2.1	EXISTING CONDITIONS.....	5
2.2	PROPOSED CONDITIONS.....	5
2.3	ROADWAY DESIGN.....	5
3.0	GRADING	5
3.1	EXISTING CONDITIONS.....	5
3.2	PROPOSED CONDITIONS.....	6
4.0	EROSION AND SEDIMENT CONTROL	6
5.0	WATER	7
5.1	EXISTING CONDITIONS.....	7
5.2	PROPOSED CONDITIONS.....	7
6.0	SANITARY SEWERS	11
6.1	EXISTING CONDITIONS.....	11
6.2	PROPOSED CONDITIONS.....	11
7.0	STORMWATER MANAGEMENT	13
7.1	EXISTING CONDITIONS.....	13
7.2	STORMWATER MANAGEMENT CRITERIA.....	13
7.2.1	<i>Stormwater Quality Control</i>	13
7.2.2	<i>Stormwater Quantity Control</i>	13
7.2.3	<i>Minor System (Storm Sewers)</i>	14
7.2.4	<i>Major System (Overland Flow)</i>	15
7.3	PROPOSED CONDITIONS.....	15
7.3.1	<i>Stormwater Management Design</i>	15
7.3.2	<i>Storm Sewers</i>	15
7.4	SWM MODELLING (PCSWMM).....	17
7.4.1	<i>Design Storms</i>	17
7.4.2	<i>Modelling Files / Schematic</i>	17
7.4.3	<i>Subcatchment Model Parameters</i>	17
7.4.4	<i>Stormwater Storage and Inlet Control Devices</i>	19
7.5	PCSWMM MODEL RESULTS.....	21
7.5.1	<i>Results – Inlet Control Devices</i>	21
7.5.2	<i>Results – Peak Flows</i>	22
7.5.3	<i>Results – Ponding Depths</i>	24
7.5.4	<i>Results – Hydraulic Grade Line</i>	25
8.0	CONCLUSIONS AND RECOMMENDATIONS	26

LIST OF TABLES

Table 2.1: Roadway Structure.....	5
Table 5.1: Watermain Design Criteria	9
Table 5.2: Water Flow Summary.....	9
Table 5.3: Summary of Hydraulic Model Results - Maximum Day + Fire Flow.....	10
Table 5.4: Summary of Hydraulic Model Results - Peak Hour Demand.....	10
Table 5.5: Summary of Hydraulic Model Results – Maximum Pressure Check	10
Table 6.1: Sanitary Sewer Design Parameters.....	11
Table 7.1: Storm Sewer Design Parameters	15
Table 7.2: Hydrologic Modelling Parameters.....	18
Table 7.3: Total Storage Provided (Surface and Underground).....	20
Table 7.4: Inlet Control Devices and Design Flows	21
Table 7.5 Woodroffe Ditch Pre-Development vs Post-Development Peak Flows	22
Table 7.6: Woodroffe Storm Sewer Pre-Development vs Post-Development Peak Flows	23
Table 7.7: Ponding Depths.....	24
Table 7.8: Stormwater 100-year HGL Elevations	25

LIST OF FIGURES

- Figure 1: Key Plan
- Figure 2: Site Plan
- Figure 3: Watermain Layout
- Figure 4: Sanitary Sewer Network
- Figure 5: Storm Sewer Network

APPENDICES

- Appendix A: Watermain Boundary Conditions, FUS Calculations, Modelling Results
- Appendix B: Sanitary Design Sheets, Sanitary Correspondance
- Appendix C: STM Design Sheets, SWM Excerpts and PCWMM Modelling Info

1.0 INTRODUCTION

The subject site is located within Barrhaven, 100 metres south of the Woodroffe Avenue and Paul Metvier Drive intersection. The site is approximately 2.36 hectares and is bounded by existing residential and the Longfields Community Church to the north, Woodroffe Avenue to the east, and existing residential lands to the south and west. A key plan of the area is presented below in **Figure 1**.

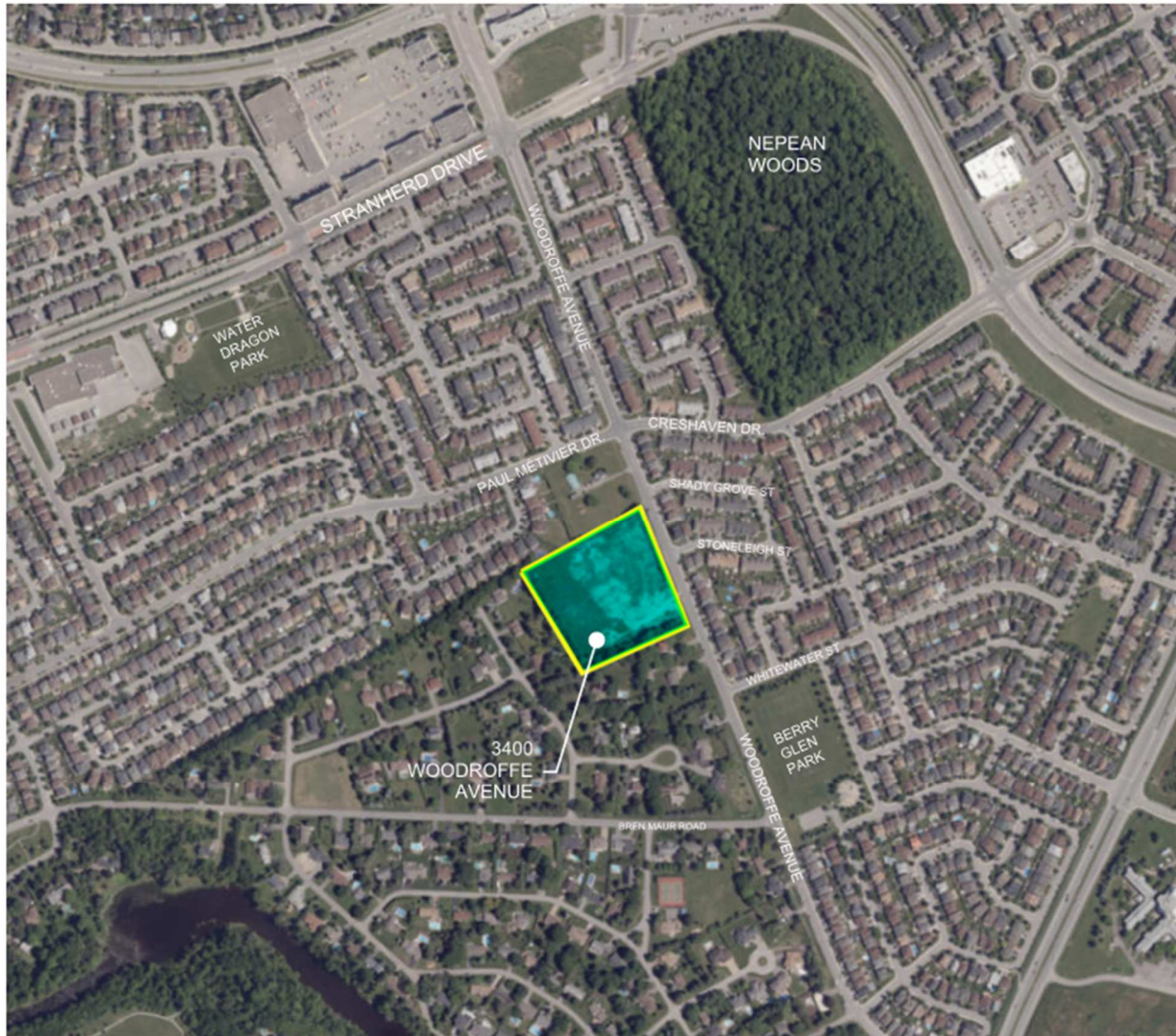

Figure 1: Key Plan

The site is vacant with an approximate 10m strip of wooded area running along the west and south property lines. The proposed development will consist of 160 units mixed between nine Terrace Flats blocks (108 units), three three-storey back-to-back Townhome blocks (32 units) and four townhome blocks (20 units). The proposed site plan is shown in **Figure 2**.

This Servicing Design Brief provides information on the considerations and approach by which Novatech has analyzed the existing site information for the subject site, and details how the

development lands will be serviced while meeting the City requirements and all other relevant regulations.

This report should be read in conjunction with the following:

- Geotechnical Investigation, 'Proposed Residential Development, 3400 Woodroffe Avenue, Ottawa, Ontario' prepared by Paterson dated October 3, 2024.



Figure 2: Site Plan

2.0 ROADWAYS

2.1 Existing Conditions

Currently there is access to the site via Woodroffe Avenue. Woodroffe Avenue is classified as a Major Collector in the 2013 City of Ottawa Transportation Master Plan.

2.2 Proposed Conditions

The development will be accessed from a single entrance at the intersection of Woodroffe Avenue and Stoneleigh Street.

The internal roads within the development are 6.0m private roads with at-grade parking, with the entrance roadway connecting to Woodroffe Avenue at 6.7m.

2.3 Roadway Design

Paterson has prepared a Geotechnical Investigation report for the development (October 2024) that provides recommendations for roadway structure, servicing and foundations. The site consists of private roads and at-grade parking; the recommended roadway structure is as follows:

Table 2.1: Roadway Structure

Roadway Material Description	Pavement Structure Layer Thickness (mm)	
	Driveways	Private Road
Asphalt Wear Course: Superpave 12.5 (Class B)	50	40
Asphalt Binder Course: Superpave 19.0 (Class B)		50
Base: Granular A	150	150
Sub-Base: Granular B – Type II	<u>300</u>	<u>450</u>
Total	500	690

3.0 GRADING

3.1 Existing Conditions

There is a ridge running down the centre of the site, from north to south. The eastern half slopes towards the Woodroffe Avenue ditch and the western half slopes towards the wooded area running along the western property line. The wooded area discharges to existing grassed swales that outlet to the Newland Drive roadside ditch.

A Geotechnical Investigation was carried out by Paterson which included 9 test pits. The subsurface consists of a relatively thin layer of fill underlain by glacial till composed of compact to very dense, brown silty sand with gravel, cobbles and boulders. The amount of gravel, cobbles and boulders was noted to gradually increase with depth, varying approximately from 40 to 70 percent of the total composition of the glacial till. Practical refusal in the glacial till was encountered

at a maximum depth of 3.3 meters below the existing ground surface. No groundwater infiltration was noted within the test pit locations prior to backfilling.

3.2 Proposed Conditions

Due to the Sites geography, the internal roadways are set approximately 2.0m above Woodroffe Avenue. In order to meet existing elevations along Woodroffe avenue, a terraced retaining wall (ranging from 1.5m to 2.7m) will be constructed adjacent buildings 3 to 7 fronting Woodroffe Avenue. Existing elevations will be met along the remaining property lines using a combination of 3:1 tie-ins and retaining walls. A 10.0m wide landscape buffer is to be maintained along the west and south property lines. For detailed grading refer to drawing 124147-GR.

The proposed grading will fall within these ranges:

- Landscaped Area: Minimum 1% - Maximum 6%
- Rearyard Swales: Minimum 1.5% (1.0% with subdrain)
- Maximum Terracing Grade of 3H:1V

4.0 EROSION AND SEDIMENT CONTROL

Erosion and sediment control measures will be implemented during construction in accordance with the "Guidelines on Erosion and Sediment Control for Urban Construction Sites" (Government of Ontario, May 1987). An Erosion and Sediment Control Plan will be prepared as part of the detailed design.

Typical erosion and sediment control measures recommended include, but are not limited to, the use of silt fences around perimeter of site (OPSD 219.110), catch basin inserts under catch basin/maintenance hole lids, heavy duty silt fence barrier (OPSD 219.130), straw bale check dams (OPSD 219.180), rock check dams (219.210 or OPSD 219.211), riprap (OPSS 511), mud mats, silt bags for dewatering operations, topsoil and sod to disturbed areas and natural grassed waterways. Dewatering and sediment control techniques will be developed for the individual situations based on the above guidelines and utilizing typical measures to ensure erosion and sediment control is controlled in an acceptable manner and there is no negative impact to adjacent Lands, water bodies or water treatment/conveyance facilities.

It will be the responsibility of the Contractor to submit a detailed construction schedule and appropriate staging, dewatering and erosion and sediment control plans to the Contract Administrator for review and approval prior to the commencement of work.

General Erosion and Sediment Control Measures

- All erosion and sediment control measures are to be installed to the satisfaction of the engineer, the municipality and the conservation authority prior to undertaking any site alterations (filling, grading, removal of vegetation, etc.) and remain present during all phases of site preparation and construction.
- A qualified inspector, provided by the owner, should conduct daily visits during construction to ensure that the contractor is working in accordance with the design drawings and that mitigation measures are being implemented as specified.
 - A light duty silt fence barrier is to be installed in the locations shown on the Erosion and Sediment Control Plan.
 - Rock check dams and/or straw bales are to be installed in drainage ditches.

- Catch basin inserts are to be placed under the grates of all existing and proposed catchbasins and structures.
- After complete build-out, all sewers are to be inspected and cleaned and all sediment and construction fencing is to be removed.
- The contractor shall ensure that proper dust control is provided with the application of water (and if required, calcium chloride) during dry periods.
- The contractor shall immediately report to the engineer or inspector any accidental discharges of sediment material into any ditch or sewer system. Appropriate response measures shall be carried out by the contractor without delay.

The contractor acknowledges that failure to implement erosion and sediment control measures may result in penalties imposed by any applicable regulatory agency.

5.0 WATER

5.1 Existing Conditions

The proposed development is located inside the SUC Pressure Zone. An existing 300mm diameter watermain runs along Woodroffe Avenue. The original dwellings, which have been demolished, were serviced by private wells.

Any existing private wells will be decommissioned by a licensed well driller in accordance with O. Reg. 903 s.21.

5.2 Proposed Conditions

The proposed development will be connected to the existing 300mm watermain by way of two separate feed points. One connection is proposed at the Site entrance, and the other connection will be made south of Building 7. For detailed watermain layout refer to drawing 124147-GP.

The development will be serviced by 200mm diameter watermains and will provide sufficient capacity to maintain appropriate pressures and fire flows throughout the development. **Figure 3** provides a high-level schematic of the proposed water distribution system.

The watermain boundary conditions below were obtained from the City of Ottawa and have been included in **Appendix A**. Interim and ultimate boundary conditions were provided as the SUC Pressure Zone will be undergoing reconfiguration. Both scenarios will be analyzed to ensure appropriate pressures are maintained.

Boundary Condition #1 – Woodroffe North connection (Shown in **Appendix A**)

Pre-SUC Reconfiguration

Maximum HGL = 154.5m
 Peak Hour = 142.0m
 Max Day + FF of 150 L/s = 142.0m
 Max Day + FF of 233 L/s = 137.3m

Post-SUC Reconfiguration

Maximum HGL = 146.9m
 Peak Hour = 143.5m
 Max Day + FF of 150 L/s = 142.2m
 Max Day + FF of 233 L/s = 139.9m

Boundary Condition #2 – Woodroffe South connection (Shown in **Appendix A**)

Pre-SUC Reconfiguration

Maximum HGL = 154.5m
 Peak Hour = 142.0m

Post-SUC Reconfiguration

Maximum HGL = 146.9m
 Peak Hour = 143.5m

Max Day + FF of 150 L/s = 142.0m
 Max Day + FF of 233 L/s = 136.7m

Max Day + FF of 150 L/s = 142.0m
 Max Day + FF of 233 L/s = 139.4m

City of Ottawa watermain design parameters are outlined in **Table 5.1**.



Figure 3: Watermain Layout

Table 5.1: Watermain Design Criteria

Design Parameter	Design Criteria
Terra Flats Unit Population	1.8 people/unit
Townhome Unit Population	2.7 people/unit
Density	160 units
Residential Demand	280 L/c/d
Maximum Day Demand	2.5 x Average Day
Peak Hour Demand	2.2 x Maximum Day
Fire Demand	183 L/s (Building 3) 200 L/s (Buildings 1, 4, 5, 6, 14, 15) 217 L/s (Buildings 7, 8, 9, 12) 233 L/s (Building 2, 13, 16) 267 L/s (Buildings 10, 11)
Maximum Pressure	690 kPa (100psi) unoccupied areas
Maximum Pressure	552 kPa (80psi) occupied areas outside of ROW
Minimum Pressure	275 kPa (40 psi) except during fire flow
Minimum Pressure	140 kPa (20 psi) fire flow conditions

Table 5.2: Water Flow Summary

Unit Type	Units	Population	Average Day Demand (L/s)	Maximum Day Demand (L/s)	Peak Hour Demand (L/s)
<i>Build-Out</i>					
Terra Flats	108	194.4	0.630	1.575	3.465
Towns/Back-to-Back Towns	52	140.4	0.455	1.138	2.503
Total	160	334.8	1.085	2.713	5.968

Fire Flow was calculated based on the Fire Underwriter’s Survey Guidelines for the proposed buildings. The fire flows range from 183 L/s to 267 L/s. The analysis assumed the worst-case fire flow of 267 L/s ensuring appropriate pressures will be achieved under all scenarios. OBC fire flows have been included for reference purposes per Technical Bulletin IWSTB-2024-05. Calculations are provided in **Appendix A**.

The proposed watermain was modeled using EPANET 2.

A summary of the model results are shown below in **Table 5.3**, **Table 5.4** and **Table 5.5**. Full model results are included in **Appendix A**.

Table 5.3: Summary of Hydraulic Model Results - Maximum Day + Fire Flow

Operating Condition	Minimum Pressure	
	Pre-SUC Reconfiguration	Post-SUC Reconfiguration
267 L/s (HYD1 = 95L/s, HYD4 = 95L/s, HYD2 = 77L/s)	205.23 kPa (HYD2, T6)	241.33 kPa (HYD2)
267 L/s (HYD2 = 95L/s, HYD3 = 95L/s, HYD4 = 77L/s)	185.31 kPa (T7)	221.41 kPa (T7)

Table 5.4: Summary of Hydraulic Model Results - Peak Hour Demand

Operating Condition	Maximum Pressure		Minimum Pressure	
	Pre-SUC Reconfiguration	Post-SUC Reconfiguration	Pre-SUC Reconfiguration	Post-SUC Reconfiguration
5.968 L/s through system	381.51 kPa (N1)	396.23 kPa (N1)	371.01 kPa (CAP6, CAP8)	385.73 kPa (CAP6, CAP8)

Table 5.5: Summary of Hydraulic Model Results – Maximum Pressure Check

Operating Condition	Maximum Pressure		Minimum Pressure	
	Pre-SUC Reconfiguration	Post-SUC Reconfiguration	Pre-SUC Reconfiguration	Post-SUC Reconfiguration
1.085 L/s through system	504.14 kPa (N1)	429.58 kPa (N1)	493.74 kPa (CAP6, CAP8)	419.18 kPa (CAP6, CAP8)

The hydraulic modelling summarized above highlights the maximum and minimum system pressures during Peak Hour/Maximum Pressure Check conditions, and the minimum system pressures during the Maximum Day + Fire condition. Since the Maximum Day + Fire Flow pressures are above the minimum 140 kPa, the Peak Hour Pressures onsite fall within the normal operating pressure range (345 kPa to 552 kPa) and the average day pressures throughout the system are below 552 kPa the proposed development can therefore be adequately serviced by the proposed network under both interim and ultimate conditions.

6.0 SANITARY SEWERS

6.1 Existing Conditions

A 200mm diameter sanitary stub to the 3400 Woodroffe Avenue property was installed in 2014 when the main line sewers were being installed within Woodroffe Avenue and was connected to the existing sanitary manhole in Stoneleigh Street. There was no allocation for the proposed Site during the design of Woodroffe Avenue and Stoneleigh Street sanitary sewers.

The previous dwellings located on the property were serviced with private sewage systems. Any on-site sewage systems should be decommissioned in accordance with Schedule 10 Decommissioning Requirements for Out-of-Service Septic Systems from the Ottawa Septic System Office (lands to be used for other purposes after decommissioning).

6.2 Proposed Conditions

The peak design flow parameters in **Table 6.1** have been used in the sewer capacity analysis.

Unit and population densities and all other design parameters are specified in the City of Ottawa Sewer Design Guidelines (October, 2025) and Technical bulletin ISTB-2018-01.

Table 6.1: Sanitary Sewer Design Parameters

Parameter	Design Parameter
Terra Flats Unit Population	1.8 people/unit
Townhome Unit Population	2.7 people/unit
Terra Flats Unit Density	108 Units (per Site Plan)
Townhome Unit Density	52 Units (per Site Plan)
Residential Flow Rate, Average Daily	280 L/cap/day
Residential Peaking Factor	Harmon Equation (min=2.0, max=4.0)
Total Infiltration Rate	0.33 L/s/ha
Minimum Pipe Size	200 mm
Minimum Velocity	0.6 m/s
Maximum Velocity	3.0 m/s

Sanitary flow from the Site will connect to the existing 200mm diameter sanitary stub located at the entrance to Woodroffe Avenue with a peak design flow of 4.3 L/s directed to the Stoneleigh Street sanitary sewers. The existing sanitary sewers have been analyzed downstream of the Site and illustrates that there is adequate capacity to accommodate the proposed development. See **Appendix B** for sanitary sewer design sheets.



7.0 STORMWATER MANAGEMENT

7.1 Existing Conditions

Under existing conditions, runoff from the east half of the site flows overland to the west side ditch of Woodroffe Avenue and outlets to the Rideau River south of Prince of Wales Drive. Runoff from the west half of the site flows overland to the west property line into a wooded area before outletting to the Newland Drive roadside ditches.

7.2 Stormwater Management Criteria

7.2.1 Stormwater Quality Control

The existing Woodroffe Avenue storm sewers direct flow to the Strandherd Stormwater Management Facility on Prince of Wales Drive, which outlets to the Rideau River. The SWMF was not sized to include the catchment area from 3400 Woodroffe Avenue. However, the overall drainage area used for the design of the SWMF was 315 ha (refer to Appendix C for documentation). Since the construction of the Pond, a more detailed analysis of the drainage area was required to account for future development. The outcome of this study resulted in a reduction of the total drainage area contributing to the SWMF to 300 ha. As a result, there is sufficient capacity in the Pond to accommodate the 2.1 ha from our Site directed to the storm sewers in Woodroffe Avenue.

7.2.2 Stormwater Quantity Control

The existing storm sewers in Woodroffe Avenue were designed to accommodate the minor system flows from the Site. The Woodroffe Avenue storm sewer design assumed a drainage area of 2.48 ha (2.36 ha from 3400 Woodroffe Avenue) with a runoff coefficient of 0.50 for pipe run 201 to 202 which resulted in a peak flow of 204.6 L/s. Although the Woodroffe Avenue storm sewer was designed to accommodate additional flow from our Site, the downstream trunk sewers directing flow to the SWMF were designed limiting runoff rates to 70 L/s/ha from contributing areas based on the South Nepean Urban Area Study. These criteria result in an allowable release rate of:

$$\begin{aligned} 70 \text{ L/s/ha} \times 2.36 \text{ ha (3400 Woodroffe Avenue)} &= 165.2 \text{ L/s} \\ 70 \text{ L/s/ha} \times 0.056 \text{ ha (Woodroffe ROW)} &= 3.9 \text{ L/s} \\ \text{Total} &= 169.1 \text{ L/s (minor system to Woodroffe storm sewers)} \end{aligned}$$

Flows directed to the west side ditch along Woodroffe Avenue and flows directed towards the western property line will be reduced under post-development conditions. Pre-development release rates have been calculated using the Rational Method with the following parameters:

Runoff Directed to Woodroffe Avenue Ditch

- *Drainage Area*
 - 1.221 ha (EX-02, EX-03)
- *Runoff Coefficient*
 - 0.29 (based on measurement of hard and soft surfaces)
 - Runoff coefficient for 'soft' and 'hard' surfaces = 0.20 and 0.90, respectively.
 - Runoff coefficient increased by 25%, up to a maximum value of 1.00, for the 100-year event.

- *Rainfall Intensity*
 - Based on City of Ottawa IDF data (Ottawa Sewer Design Guidelines)
 - *Time-of-Concentration*
 - 10 minutes (derived using Uplands Method).

The (pre-development) release rates are as follows. Refer to **Appendix C** for supporting calculations:

2-year	75.6 L/s
5-year	102.6 L/s
100-year	210.0 L/s

Runoff Directed to Western Property Line (Newland Drive Ditch)

- *Drainage Area*
 - 1.286 ha (EX-01)
- *Runoff Coefficient*
 - 0.23 (based on measurement of hard and soft surfaces)
 - Runoff coefficient for 'soft' and 'hard' surfaces = 0.20 and 0.90, respectively.
 - Runoff coefficient increased by 25%, up to a maximum value of 1.00, for the 100-year event.
- *Rainfall Intensity*
 - Based on City of Ottawa IDF data (Ottawa Sewer Design Guidelines)
 - *Time-of-Concentration*
 - 10 minutes (derived using Uplands Method).

The (pre-development) release rates are as follows. Refer to **Appendix C** for supporting calculations:

2-year	63.2 L/s
5-year	85.7 L/s
100-year	180.1 L/s

In addition, as per the City of Ottawa Sewer Design Guidelines (October, 2025) – Technical Bulletin (PIEDTB-2016-01, September 6, 2016):

“There is to be no surface ponding on private roads or private parking areas for the 2-year storm event.”

Based on the above criteria, underground storage will be required to prevent surface ponding on roads and parking areas during a 2-year storm event. Surface storage can be used to meet the allowable release rate for storms greater than the 2-year event.

7.2.3 Minor System (Storm Sewers)

The storm sewers comprising the minor system have been designed using the principles of dual drainage based on the criteria outlined in the *Ottawa Sewer Design Guidelines* (October 2025), and Technical Bulletins PIEDTB-2016-01 (September 6, 2016) and ISTB-2018-01 (March 21, 2018). The design criteria used to size the storm sewers are summarized in **Table 7.1**.

Table 7.1: Storm Sewer Design Parameters

Parameter	Design Criteria
Private Roads	2-year Return Period
Storm Sewer Design	Rational Method (confirmed with PCSWMM model)
IDF Rainfall Data	Ottawa Sewer Design Guidelines
Initial Time of Concentration (T_c)	10 min
Minimum Velocity	0.8 m/s
Maximum Velocity	3.0 m/s
Minimum Diameter	250 mm

7.2.4 Major System (Overland Flow)

The Site has been designed to convey private roadway and parking area runoff from storms that exceed the minor system capacity to Woodroffe Avenue through the private entrance. The 10m landscape buffer along the south and west property lines will maintain the existing overland flow routes to Woodroffe Avenue and Newland Drive roadside ditches. The Site has been graded to ensure the 100-year peak overland flows are confined within the road/parking areas at a maximum depth of 350mm.

7.3 Proposed Conditions

7.3.1 Stormwater Management Design

Catchbasins located within private roadways, parking and landscaped areas will be controlled with inlet control devices (ICDs). To prevent surface ponding during a 2-year storm event, underground storage will be provided using either StormTech STC-800 storage chambers or catchbasin maintenance holes.

The roadway and parking areas have been graded to provide surface storage of stormwater for larger storm events (> 2-year storm). The site grading uses a maximum static ponding depth of approximately 300mm to ensure that the dynamic ponding depths during a 100-year event do not exceed 350mm.

7.3.2 Storm Sewers

The site will be serviced by storm sewers ranging from 250mm to 450mm and have been designed to convey peak flow rates associated with a 2-year rainfall event.

The proposed storm sewer system layout is shown in **Figure 5**. Storm sewer design sheets are provided in **Appendix C**.

Offsite Works

Woodroffe Avenue will be urbanized along the frontage of the Site. Catchbasins on-grade will be installed opposite the existing catchbasins located on the east side of Woodroffe Avenue. All bypass flow will be directed south along Woodroffe Avenue and eventually spill into the westside ditch.



Figure 5: Storm Sewer Network

7.4 SWM Modelling (PCSWMM)

The *Ottawa Sewer Design Guidelines* (October 2025) require hydrologic modelling for all dual drainage systems. Post-development conditions were assessed using PCSWMM. The software simulates dual drainage networks (i.e. storm sewers and roads) as separate but connected systems and has the capability to generate and route storm runoff through a drainage network of pipes, channels, storage/treatment units, and diversion structures.

The PCSWMM model was used to:

- Simulate the performance of the storm sewer network (minor system), and overland flows along the road network;
- Evaluate overland flow depths and ponding volumes;
- Evaluate the 100-year hydraulic grade line (HGL) in the proposed storm sewers; and,
- Confirm the required storage volumes and release rates.

7.4.1 Design Storms

The SWM modelling was completed using the following synthetic design storms. The design storms were generated using IDF curves from the City of Ottawa Sewer Design Guidelines (October 2025).

3-hour Chicago Storm Distribution

2-year 3-hour Chicago storm
5-year 3-hour Chicago storm
100-year 3-hour Chicago storm
100-year (+20%) 3-hour Chicago storm

12-hour SCS Storm Distribution

2-year 12-hour SCS storm
5-year 12-hour SCS storm
100-year 12-hour SCS storm
100-year (+20%) 12-hour SCS storm

The 3-hour Chicago distribution was determined to be the critical storm distribution for the design of the storm drainage system and thus was used for the design and analysis. The proposed drainage system has also been stress tested using a 3-hour Chicago design storm that has a 20% higher intensity and total volume compared to the 100-year event.

7.4.2 Modelling Files / Schematic

The PCSWMM model schematics, storage curves, and model output are provided in **Appendix C** and will be provided electronically.

7.4.3 Subcatchment Model Parameters

The hydrologic parameters for each subcatchment were developed based on the areas shown on the Post-Development Storm Drainage Area Plans (Drawing's 124147-STM2). Drainage areas were delineated based on the existing or proposed site grading. Model parameters are provided in **Table 7.2**.

Table 7.2: Hydrologic Modelling Parameters

Area ID	Catchment Area (ha)	Runoff Coefficient (C)	Percent Impervious (%)	Zero-Imperv. (%)	Equivalent Width (m)	Average Slope (%)
On-site Controlled Areas						
A-01	0.147	0.42	31	95	92	2
A-02	0.118	0.47	38.9	95	74	2
A-03	0.115	0.78	83.3	43	46	2.5
A-04	0.096	0.76	79.6	53	48	2
A-05	0.095	0.76	80.3	41	48	1
A-06	0.079	0.64	62.7	85	53	1.5
A-07	0.092	0.74	77.1	29	46	2
A-08	0.065	0.76	80.3	22	33	2
A-09	0.090	0.79	84	60	56	2
A-10	0.074	0.75	79.1	36	37	2
A-11	0.120	0.76	80.7	42	40	2
A-12	0.160	0.78	82.4	48	53	2
A-13	0.088	0.80	86.4	60	55	2
A-14	0.084	0.78	82.1	36	28	3
A-15	0.119	0.76	79.8	38	40	2
A-16	0.082	0.53	47.6	0	27	6
A-19	0.090	0.77	81.6	53	45	2
A-20	0.061	0.73	75.7	25	31	2
A-24	0.023	0.34	20.4	95	23	2
A-25	0.054	0.65	64.3	66	36	1
A-26	0.023	0.50	43.5	95	23	2
A-27	0.015	0.75	78.6	91	15	2
A-28	0.015	0.75	78.6	91	15	2
A-29	0.016	0.67	66.7	95	16	2
A-30	0.013	0.74	76.9	95	13	2
A-31	0.015	0.75	77.9	92	15	2
A-32	0.015	0.75	77.9	92	15	2
A-33	0.015	0.71	73.3	91	15	2
A-34	0.015	0.75	78.6	91	15	2
A-35	0.015	0.67	66.7	95	15	2
On-site Uncontrolled Areas						
A-21	0.204	0.20	0	0	204	2
A-22	0.055	0.20	0	0	55	2
A-23	0.025	0.31	22.9	0	17	2
Off-site Controlled Areas (Woodroffe Avenue CBs)						
A-17	0.116	0.47	39.2	0	58	2
A-18	0.135	0.57	52.5	0	68	2
Off-Site Existing Areas (Tributary to Woodroffe Storm Sewers)						
EX-01	0.137	0.60	57.1	50	69	2
EX-02	0.078	0.60	57.1	50	39	2
EX-03	0.089	0.60	57.1	50	45	2
EX-04	0.067	0.60	57.1	50	34	2
EX-05	0.168	0.60	57.1	50	84	2
EX-06	0.18	0.60	57.1	95	120	1
EX-07	0.35	0.60	57.1	50	175	2
EX-08	0.46	0.60	57.1	50	230	2

Area ID	Catchment Area (ha)	Runoff Coefficient (C)	Percent Impervious (%)	Zero-Imperv. (%)	Equivalent Width (m)	Average Slope (%)
EX-09	0.42	0.60	57.1	25	210	2
EX-10	0.15	0.60	57.1	0	75	2
EX-11	0.15	0.60	57.1	0	75	2
EX-12	5.8	0.65	64.3	50	1305	1
EX-13	0.36	0.60	57.1	0	180	2
EX-14	0.41	0.60	57.1	0	205	2
EX-15	0.51	0.60	57.1	95	340	1

Infiltration

Infiltration losses have been modeled using Horton's infiltration equation, which defines the infiltration capacity of the soil over the duration of a precipitation event using a decay function that ranges from an initial maximum infiltration rate to a minimum rate as the storm progresses. The following values were used for all catchments.

Horton's Equation:
 $f(t) = f_c + (f_o - f_c)e^{-k(t)}$

Initial infiltration rate: $f_o = 76.2$ mm/hr

Final infiltration rate: $f_c = 13.2$ mm/hr

Decay Coefficient: $k = 4.14$ /hr

Depression Storage

The following values for depression storage were applied to all catchments.

- Depression Storage (pervious areas): 4.67 mm
- Depression Storage (impervious areas): 1.57 mm

Building rooftops were assumed to provide no depression storage.

Equivalent Width

'Equivalent Width' refers to the width of the subcatchment flow path. This parameter is calculated as described in the *City of Ottawa Sewer Design Guidelines, October 2025*. The equivalent width has been calculated as Area / Flow Path Length. The flow path lengths have been approximated based on the minimum direction of overland flow from the nearest edge of the subcatchment to the inlet; as per the Pre-Development and Post-Development Storm Drainage Area Plans.

Impervious Values

Impervious values for each sub catchment area were calculated based on the existing or proposed land use and correspond to the runoff coefficients shown on the Pre-Development and Post-Development Storm Drainage Area Plans based on the following equation:

$$C = 0.70(\% \text{ IMP}) + 0.20$$

Zero impervious is calculated as the percentage of the total impervious area with no depression storage (generally pitched roof buildings).

7.4.4 Stormwater Storage and Inlet Control Devices

Surface storage is represented in the PCSWMM model using storage nodes and storage curves. Refer to **Appendix C** for additional details.

Underground Storage

Underground storage will be provided using catchbasin maintenance holes or StormTech STC-800 (arch type) storage chambers connected to select catchbasins within the private road and parking areas. The underground storage chambers and catchbasin maintenance holes are required to prevent surface ponding during the 2-year storm event when controlling flows to the allowable release rate.

The StormTech STC-800 storage chambers have the following dimensions:

- Stone foundation depth = 150mm (min)
- Stone cover = 150mm (min)
- Stone porosity = 40%
- Size (L x W x H) = 2169mm x 1295mm x 828mm
- Chamber / minimum installed storage = 1.43 m³ / 2.22 m³

The storage volumes were determined using the StormTech design calculator based on the configurations shown on the General Plan of Services (Drawing 124147-GP). Documentation for the StormTech STC-800 storage chambers is provided in **Appendix C**.

Surface Storage

In addition to the underground storage provided for the 2-year event, surface storage will be provided to attenuate peak flows to the allowable release rates for the 5-year and 100-year storm events. Surface storage will consist of ponding above each catchbasin within the private road and parking areas.

A summary of the underground and surface storage is provided in **Table 7.3**. The extent of surface ponding is shown on the Post-Development Storm Drainage Area Plan (124147-STM2). **Table 7.3: Total Storage Provided (Surface and Underground)**

Structure ID	STM Area ID	Max Static Ponding Depth (m)	Storage Provided (m ³)			Number of StormTech STC-800 Storage Chambers
			Underground ¹	Surface ²	TOTAL	
<i>Catchbasins within Private Roadway and Parking Areas (with Underground and Surface storage)</i>						
CB01	A-12	0.32	19.3	45.2	64.5	5
CB02	A-11	0.30	17.5	50.4	67.9	5
CB03	A-03	0.30	8.7	52.9	61.6	2
CB04	A-07	0.33	8.7	46.1	54.8	2
CB05	A-15	0.30	12.5	46.3	58.8	3
CB06	A-14	0.30	8.7	38.1	46.8	2
CBMH01 (1200mm)	A-08	0.30	3.3	32.9	36.2	-
CBMH02 (1500mm)	A-05 / A-06	0.30	5.5	45.0	50.5	-
CBMH03 (1500mm)	A-04	0.20	6.3	13.7	20.0	-
CBMH04 (1500mm)	A-19	0.20	6.4	14.3	20.7	-

Structure ID	STM Area ID	Max Static Ponding Depth (m)	Storage Provided (m ³)			Number of StormTech STC-800 Storage Chambers
			Underground ¹	Surface ²	TOTAL	
CBMH05 (1800mm)	A-13	0.25	7.5	21.0	28.5	-
CBMH06 (1800mm)	A-09	0.26	8.2	15.9	24.1	-
CBMH07 (1200mm)	A-20	0.30	2.9	27.4	30.3	-
CBMH08 (1200mm)	A-10	0.30	3.2	27.9	31.1	-
TOTAL			118.7	477.1	595.8	19

¹Based on StormTech STC-800 storage calculation design spreadsheet (example provided in Appendix C)

²Based on proposed grading design / Autodesk Civil 3D (refer to Drawing 124147-STM2).

Inlet Control Devices (ICDs)

All catchbasins at sag points within the private road and parking areas will be fitted with Ipex Tempest LMF ICDs. All on-grade catchbasins located at the site entrance and along Woodroffe Avenue will be fitted with standard plate style 83mm ICDs. Refer to the Notes and Tables Plan for ICD specifications (Drawing 124147-ND).

7.5 PCSWMM Model Results

7.5.1 Results – Inlet Control Devices

Inlet Control Devices (ICDs)

ICDs are provided for specified structures within the roadway and landscaped areas. The ICD sizes and design flows are provided in **Table 7-4**. The ICDs have been sized to maximize surface storage, limit the outlet peak flows to the allowable release rates and ensure no surface ponding during a 2-year storm event.

Table 7.4: Inlet Control Devices and Design Flows

Structure ID	ICD Size & Inlet Rate						
	ICD Type	T/G (m)	Orifice Invert (m)	100-year Head on Orifice (m)	2-year Orifice Peak Flow* (L/s)	5-year Orifice Peak Flow* (L/s)	100-year Orifice Peak Flow* (L/s)
CB01	Tempest LMF	103.51	101.66	2.13	4.9	6.0	6.2
CB02	Tempest LMF	103.56	101.52	2.28	5.0	6.1	6.4
CB03	Tempest LMF	103.63	100.89	2.94	6.1	7.1	7.3
CB04	Tempest LMF	103.55	101.70	2.03	5.3	7.0	7.5
CB05	Tempest LMF	103.55	101.60	2.16	4.7	6.0	6.2
CB06	Tempest LMF	103.52	101.67	2.02	4.5	5.8	6.1
CB07	83mm	102.07	100.67	1.44	2.7	5.9	16.7
CB08	83mm	101.24	99.84	1.45	8.2	12.4	19.4
CB09	83mm	102.11	100.71	1.43	2.8	4.5	9.5
CB10	83mm	102.11	100.71	1.43	2.8	4.5	9.5
CBMH01	Tempest LMF	103.55	100.70	3.00	8.1	9.0	9.2

CBMH02	Tempest LMF	103.63	100.63	3.29	7.3	7.5	7.7
CBMH03	Tempest LMF	103.73	100.27	3.67	10.3	11.5	11.7
CBMH04	Tempest LMF	103.74	100.24	3.71	9.1	9.9	10.1
CBMH05	Tempest LMF	103.65	100.80	3.07	8.3	9.1	9.3
CBMH06	Tempest LMF	103.65	100.55	3.36	8.3	9.4	9.7
CBMH07	Tempest LMF	103.60	101.10	2.67	7.3	8.1	8.3
CBMH08	Tempest LMF	103.57	100.82	2.94	8.8	8.9	9.1
CBMH09	Tempest LMF	103.65	100.43	2.79	5.2	5.7	7.2
CBMH11	Tempest LMF	103.95	100.44	3.16	5.9	6.3	7.6
RY02	83mm	101.55	100.35	1.36	7.3	9.0	16.8
RY03	83mm	101.49	100.40	1.32	7.3	9.1	16.6
RY08	Tempest LMF	103.79	102.39	1.32	1.0	2.3	6.0

*From PCSWMM model, 3-hour Chicago storm distribution.

Both IPEX Tempest LMF and MHF ICDs are proposed for the site.

7.5.2 Results – Peak Flows

The PCSWMM model was used to evaluate the performance of the proposed storm drainage system and confirm that modelled post-development flows are controlled to the allowable release rates. The PCSWMM model output is provided in **Appendix C**.

Areas Draining to Woodroffe Avenue Roadside Ditch

Bypass flows from catchbasins on-grade (CB07, CB08, CB09, CB10) and uncontrolled runoff from the Site (Areas A-22 and A-23) are directed to the Woodroffe Avenue west side ditch. **Table 7.5** provides a summary of the peak flows directed to the ditch compared with pre-development peak flows.

Table 7.5 Woodroffe Ditch Pre-Development vs Post-Development Peak Flows

Contributing Drainage Area	Peak Flows (L/s)		
	2-year	5-year	100-year
Pre-Development Conditions (Rational Method)			
EX-02, EX-03	75.6	102.6	210.0
Post-Development Conditions (PCSWMM Model)			
Uncontrolled Areas (A-22, A-23)	1.5	7.6	28.0
Bypass Flow (CB07, CB08, CB09/10)	9.6	17.8	54.8
Total (Post-Development)	11.1	25.4	82.8

As shown above, the post-development peak flows being directed to the west side ditch of Woodroffe Avenue have significantly reduced from pre-development levels illustrating the existing ditch will not be negatively impacted from the development.

Areas Draining to Western Property Limits (Newland Drive)

Runoff from the 10m landscape buffer provided along the west and south property lines will not be altered and continue directing flow into existing grass swales to the Newland Drive roadside ditch. Flows will be significantly reduced under post-development conditions, decreasing from an area of 1.286 ha under pre-development conditions to 0.204 ha under post-development conditions.

Woodroffe Avenue 450mm diameter Storm Sewer (North to Strandherd Drive)

Table 7.6 below provides a comparison of the allowable release rate (70 L/s/ha) and the post-development flows directed to the 450mm diameter storm sewer in Woodroffe Avenue.

Table 7.6: Woodroffe Storm Sewer Pre-Development vs Post-Development Peak Flows

Contributing Drainage Area	Peak Flows (L/s)		
	2-year	5-year	100-year
Pre-Development Conditions (Rational Method)			
Allowable Release Rate	169.1		
Post-Development Conditions (PCSWMM Model)¹			
Controlled Areas (On-site)	109.1	128.8	152.5
Woodroffe Avenue (CB7)	2.7	5.9	16.4
Total (Post-Development)	111.8	134.7	168.9

¹Based on PCSWMM results for a 3-hour Chicago storm distribution.

As seen in **Table 7.6**, the total post-development peak flows will meet the allowable release rate. The on-site controlled area peak flows were taken from the PCSWMM model at the pipe run between maintenance holes 211 and 201. The Woodroffe Avenue controlled peak flows were also taken from the PCSWMM model and represent the flows captured by CB07.

Appendix C includes the approved storm sewer design sheet for the Woodroffe Avenue storm sewer from Stoneleigh Street to Chapman Mills Drive and documentation from DME Engineering, dated June 2, 2004, confirming there is sufficient capacity in the Woodroffe Avenue storm sewer and the Strandherd SWMF to accommodate the development. Additional downstream analysis has been conducted for the Woodroffe Avenue storm sewer up to the connection point to the Strandherd Drive trunk storm sewer. Subcatchments within the Woodroffe Avenue right-of-way (EX-04 to EX-05, EX-07 to EX-11, EX-13 and EX-14) have been modelled using outlet curves that control capture rates to the associated 5-year peak flows. Subcatchments consisting of existing residential development lands have been modelled to limit minor system flows to 70 L/s/ha (areas EX-06, EX-12 and EX-15). The model has assumed a conservative 5-year capture rate for the Woodroffe Avenue ROW since the roadway slopes gradually toward Strandherd Drive consisting of catchbasins on grade. The majority of peak flows will travel overland as bypass flow towards Strandherd Drive. The analysis indicates that no surcharging during the 100-year storm event will occur from MH201 to XMH1 under post-development conditions. Surcharging will occur during the 100-year storm event from XMH1 to XMH3 north of Chapman Mills Drive but is resolved at the connection to the trunk sewer in Strandherd Drive. The increase in surcharging within these pipe runs will not have any negative impacts on the stormwater system as there are only roadway catchbasins being connected to the storm sewers. **Appendix C** includes PCSWMM profiles of the 100-year HGL through the Woodroffe Avenue storm sewer for pre and post-development

conditions. The storm sewer design sheet in **Appendix C** shows Q/Q_{FULL} values greater than 100% for pipe runs between MH211 to MH202. The design sheet accounts for the full 2-year peak flows from the development being directed through the minor system but the ICDs have been designed to capture 70 L/s/ha, much less than the 2-year storm event. The PCSWMM model confirms that these pipe runs do not surcharge during the 100-year storm event.

Woodroffe Avenue 250mm diameter Storm Sewer (South to Whitewater Street)

The 250mm storm sewer directing stormwater flows south to Whitewater Street was modelled in PCSWMM to confirm the capacity for additional Woodroffe Avenue right-of-way flows captured by CB8. The model indicates that the 250mm storm sewer has sufficient capacity to accommodate the additional flows and shows no surcharging occurring during the 100-year storm event. The storm sewer design sheet and 100-year PCSWMM profiles are included in **Appendix C**.

7.5.3 Results – Ponding Depths

The major system network was evaluated using the PCSWMM model to ensure that the overland flow depths conform to the SWM design criteria.

The results of the analysis, shown in **Table 7.7**, indicate that the 100-year overland flow depths at all catchbasins will be less than 0.35m. The highlighted cells indicate locations where the dynamic ponding depth exceeds the maximum static ponding depth and spills over the high point.

Table 7.7: Ponding Depths

Structure ID	STM Area ID	Max Static Ponding Depth (m)	Ponding Depth (m) ¹				Release Rate (L/s) ¹		
			2-yr	5-yr	100-yr	100-yr (+20%)	2-yr	5-yr	100-yr
Catchbasins within Private Roadway, Parking Areas and Landscaped Areas									
CB01	A-12	0.32	0.00	0.09	0.28	0.33	4.9	6.0	6.2
CB02	A-11, A-25	0.30	0.00	0.04	0.24	0.30	5.0	6.1	6.4
CB03	A-03	0.30	0.00	0.06	0.20	0.24	6.1	7.1	7.3
CB04	A-07	0.33	0.00	0.00	0.18	0.32	5.3	7.0	7.5
CB05	A-15	0.30	0.00	0.05	0.21	0.26	4.7	6.0	6.2
CB06	A-14	0.30	0.00	0.00	0.17	0.25	4.5	5.8	6.1
CBMH01	A-08	0.30	0.00	0.05	0.15	0.19	8.1	9.0	9.2
CBMH02	A-05, A-06	0.30	0.00	0.13	0.29	0.31	7.3	7.5	7.7
CBMH03	A-04	0.20	0.00	0.08	0.21	0.22	10.3	11.5	11.7
CBMH04	A-19	0.20	0.00	0.08	0.21	0.22	9.1	9.9	10.1
CBMH05	A-13	0.25	0.00	0.09	0.22	0.26	8.3	9.1	9.3
CBMH06	A-09	0.26	0.00	0.08	0.26	0.28	8.3	9.4	9.7
CBMH07	A-20	0.30	0.00	0.05	0.17	0.26	7.3	8.1	8.3
CBMH08	A-10	0.30	0.00	0.08	0.19	0.28	8.8	8.9	9.1
CBMH09	A-26 to A-29	0.08	0.00	0.00	0.00	0.00	5.2	5.7	7.2
CBMH10	-	0.08	0.00	0.00	0.00	0.11	-	-	-
CBMH11	A-30 to A-35	0.04	0.00	0.00	0.00	0.00	5.9	6.3	7.6
CBMH12	-	0.05	0.00	0.00	0.00	0.10	-	-	-

Structure ID	STM Area ID	Max Static Ponding Depth (m)	Ponding Depth (m) ¹				Release Rate (L/s) ¹		
			2-yr	5-yr	100-yr	100-yr (+20%)	2-yr	5-yr	100-yr
LCB01	-	0.08	0.00	0.00	0.06	0.09	-	-	-
LCB02	-	0.07	0.00	0.00	0.00	0.00	-	-	-
RY01	-	0.27	0.00	0.00	0.21	0.29	-	-	-
RY02	A-02	0.25	0.00	0.00	0.21	0.29	7.3	8.9	16.8
RY03	A-01	0.31	0.00	0.00	0.29	0.33	7.3	9.1	16.6
RY04	-	0.22	0.00	0.00	0.23	0.27	-	-	-
RY05	-	0.09	0.00	0.00	0.06	0.09	-	-	-
RY06	-	0.24	0.00	0.00	0.08	0.14	-	-	-
RY07	-	0.13	0.00	0.00	0.10	0.13	-	-	-
RY08	A-24	0.15	0.00	0.00	0.03	0.08	1.0	2.3	6.0
RY09	-	0.05	0.00	0.00	0.00	0.00	-	-	-
RY10	-	0.05	0.00	0.00	0.00	0.00	-	-	-
RY11	-	0.05	0.00	0.00	0.00	0.00	-	-	-
RY12	-	0.05	0.00	0.00	0.00	0.00	-	-	-
RY13	-	0.05	0.00	0.00	0.00	0.00	-	-	-
RY14	-	0.05	0.00	0.00	0.00	0.00	-	-	-

¹Based on PCSWMM results for a 3-hour Chicago storm distribution.

7.5.4 Results – Hydraulic Grade Line

The hydraulic grade line in the proposed storm sewers was evaluated using the PCSWMM model. In addition, a stress test was applied using a 3-hour Chicago design storm that has a 20% higher intensity and total volume compared to the 100-year event. The 100-year HGL elevations at each STMMH are provided in **Table 7.8**.

Table 7.8: Stormwater 100-year HGL Elevations

MH ID	Obvert Elevation (m)	T/G Elevation (m)	HGL Elevation ¹ (m)	Surcharge (m)	Clearance from T/G (m)	HGL in Stress Test ¹ (m)
211	99.72	102.29	99.62	0	2.67	99.64
212	100.13	103.78	99.83	0	3.95	99.83
213	100.21	103.78	100.03	0	3.75	100.03
214	100.52	103.90	100.30	0	3.60	100.30
215	100.24	103.90	100.01	0	3.89	100.01
216	100.43	103.85	100.20	0	3.65	100.20
217	100.46	103.89	100.24	0	3.65	100.25
CB02 ²	101.82	103.56	101.57	0	1.99	101.57
CB03 ²	101.19	103.60	100.95	0	2.65	100.95
CB05 ²	101.90	103.55	101.65	0	1.90	101.65
CBMH02 ²	100.93	103.63	100.69	0	2.94	100.69
CBMH03 ²	100.57	103.73	100.38	0	3.35	100.38
CBMH04 ²	100.54	103.74	100.32	0	3.42	100.32

¹Based on PCSWMM results for a 3-hour Chicago storm distribution.

² HGL is based on water level downstream of the ICD.

Refer to **Appendix C** for an expanded table comparing HGL elevations to design USF elevations. The expanded table shows that the USF elevations are well above the modelled HGL at their corresponding connections to the storm sewer providing the requirement 0.30m minimum clearance between the USF and the 100-year HGL.

8.0 CONCLUSIONS AND RECOMMENDATIONS

The report conclusions are as follows:

- 1) The proposed storm system will control post-development flow to the allowable release rates for all outlet locations. All runoff volume from the 100-year storm event is stored on site. The existing Strandherd Stormwater Management Facility provides the required level of water quality control for flows directed to the Woodroffe Avenue storm sewer prior to discharge to the Rideau River.
- 2) The proposed sanitary sewer conforms to City design criteria and provides a gravity outlet for the development site. There is sufficient capacity in the Stoneleigh Street sanitary sewer to accommodate the development.
- 3) Connection to the existing watermain in Woodroffe Avenue will provide municipal water service to the development.
- 4) There is adequate fire protection to the proposed development, in accordance with the Fire Underwriter's Survey.
- 5) The proposed infrastructure (sanitary, storm and water) complies with City of Ottawa design standards.

This report is respectfully submitted for review and approval. Please contact the undersigned should you have questions or require additional information.

Sincerely,

NOVATECH

Prepared By:



Lucas Wilson, P.Eng.
Project Engineer

Reviewed By:



Mark Bissett., P.Eng.
Senior Project Manager

APPENDIX A: Hydraulic Analysis

Watermain Boundary Conditions

FUS Calculations

Modelling Results

Boundary Conditions 3400 Woodroffe Avenue

Provided Information

Scenario	Demand	
	L/min	L/s
Average Daily Demand	81	1.36
Maximum Daily Demand	203	3.39
Peak Hour	448	7.46
Fire Flow Demand #1	9,000	150.00
Fire Flow Demand #2	14,000	233.33

Location



Results

Existing Condition (Pre- SUC Pressure Zone Reconfiguration)

Connection 1 – Woodroffe North

Demand Scenario	Head (m)	Pressure ¹ (psi)
Maximum HGL	154.5	74.6
Peak Hour	142.0	56.7
Max Day plus Fire Flow #1	142.0	56.7
Max Day plus Fire Flow #2	137.3	50.1

¹ Ground Elevation = 102.1 m

Connection 2 – Woodroffe South

Demand Scenario	Head (m)	Pressure ¹ (psi)
Maximum HGL	154.5	77.1
Peak Hour	142.0	59.3
Max Day plus Fire Flow #1	142.0	59.3
Max Day plus Fire Flow #2	136.7	51.7

¹ Ground Elevation = 100.3 m

Future Condition (Post- SUC Pressure Zone Reconfiguration)

Connection 1 – Woodroffe North

Demand Scenario	Head (m)	Pressure ¹ (psi)
Maximum HGL	146.9	63.7
Peak Hour	143.5	58.9
Max Day plus Fire Flow #1	142.2	57.1
Max Day plus Fire Flow #2	139.9	53.8

¹ Ground Elevation = 102.1 m

Connection 2 – Woodroffe South

Demand Scenario	Head (m)	Pressure ¹ (psi)
Maximum HGL	146.9	66.3
Peak Hour	143.5	61.5
Max Day plus Fire Flow #1	142.0	59.3
Max Day plus Fire Flow #2	139.4	55.6

¹ Ground Elevation = 100.3 m

Notes

1. The IWSD has recently updated their water modelling software. Any significant difference between previously received BC results and newly received BC results could be attributed to this update.

Disclaimer

The boundary condition information is based on current operation of the city water distribution system. The computer model simulation is based on the best information available at the time. The operation of the water distribution system can change on a regular basis, resulting in a variation in boundary conditions. The physical properties of watermains deteriorate over time, as such must be assumed in the absence of actual field test data. The variation in physical watermain properties can therefore alter the results of the computer model simulation. Fire Flow analysis is a reflection of available flow in the watermain; there may be additional restrictions that occur between the watermain and the hydrant that the model cannot take into account.

FUS - Fire Flow Calculations

As per 1999 Fire Underwriter's Survey Guidelines



Engineers, Planners & Landscape Architects

Novatech Project #: 124147
Project Name: 3400 Woodroffe Avenue
Date: 11/5/2025
Input By: Lucas Wilson
Reviewed By: Mark Bissett

Building Description: Bldg #1
Wood frame

Step	Input		Value Used	Total Fire Flow (L/min)		
Base Fire Flow						
1	Construction Material		Multiplier	1.5		
	Coefficient related to type of construction C	Wood frame	Yes		1.5	
		Ordinary construction			1	
		Non-combustible construction			0.8	
		Modified Fire resistive construction (2 hrs)			0.6	
Fire resistive construction (> 3 hrs)			0.6			
2	Floor Area		1,035	11,000		
	A	Building Footprint (m ²)			345	
		Number of Floors/Storeys			3	
		Area of structure considered (m ²)				
F	Base fire flow without reductions					
Reductions or Surcharges						
3	Occupancy hazard reduction or surcharge		Reduction/Surcharge	8,250		
	(1)	Non-combustible	Yes		-25%	
		Limited combustible			-15%	
		Combustible			0%	
		Free burning			15%	
Rapid burning			25%			
4	Sprinkler Reduction		Reduction	0		
	(2)	Adequately Designed System (NFPA 13)			-30%	
		Standard Water Supply			-10%	
		Fully Supervised System			-10%	
Cumulative Total			0%			
5	Exposure Surcharge (cumulative %)		Surcharge	4,125		
	(3)	North Side	30.1 - 45 m		5%	
		East Side	3.1 - 10 m		20%	
		South Side	20.1 - 30 m		10%	
		West Side	10.1 - 20 m		15%	
Cumulative Total			50%			
Results						
6	(1) + (2) + (3)	Total Required Fire Flow, rounded to nearest 1000L/min		L/min	12,000	
		(2,000 L/min < Fire Flow < 45,000 L/min)		or	L/s	200
				or	USGPM	3,170
7	Storage Volume	Required Duration of Fire Flow (hours)		Hours	2.5	
		Required Volume of Fire Flow (m ³)		m ³	1800	

FUS - Fire Flow Calculations

As per 1999 Fire Underwriter's Survey Guidelines



Engineers, Planners & Landscape Architects

Novatech Project #: 124147
Project Name: 3400 Woodroffe Avenue
Date: 11/5/2025
Input By: Lucas Wilson
Reviewed By: Mark Bissett

Building Description: Bldg #2
Wood frame

Step	Input		Value Used	Total Fire Flow (L/min)		
Base Fire Flow						
1	Construction Material		Multiplier	1.5		
	Coefficient related to type of construction C	Wood frame	Yes		1.5	
		Ordinary construction			1	
		Non-combustible construction			0.8	
		Modified Fire resistive construction (2 hrs)			0.6	
Fire resistive construction (> 3 hrs)			0.6			
2	Floor Area			11,000		
	A	Building Footprint (m ²)	345		1,035	
		Number of Floors/Storeys	3			
		Area of structure considered (m ²)				
	F	Base fire flow without reductions				
$F = 220 C (A)^{0.5}$						
Reductions or Surcharges						
3	Occupancy hazard reduction or surcharge		Reduction/Surcharge	8,250		
	(1)	Non-combustible	Yes		-25%	
		Limited combustible			-15%	
		Combustible			0%	
		Free burning			15%	
Rapid burning			25%			
4	Sprinkler Reduction		Reduction	0		
	(2)	Adequately Designed System (NFPA 13)			-30%	
		Standard Water Supply			-10%	
		Fully Supervised System			-10%	
Cumulative Total			0%			
5	Exposure Surcharge (cumulative %)		Surcharge	5,775		
	(3)	North Side	3.1 - 10 m		20%	
		East Side	3.1 - 10 m		20%	
		South Side	20.1 - 30 m		10%	
		West Side	3.1 - 10 m		20%	
Cumulative Total			70%			
Results						
6	(1) + (2) + (3)	Total Required Fire Flow, rounded to nearest 1000L/min		L/min	14,000	
		(2,000 L/min < Fire Flow < 45,000 L/min)		or	L/s	233
				or	USGPM	3,699
7	Storage Volume	Required Duration of Fire Flow (hours)		Hours	3	
		Required Volume of Fire Flow (m ³)		m ³	2520	

FUS - Fire Flow Calculations

As per 1999 Fire Underwriter's Survey Guidelines



Engineers, Planners & Landscape Architects

Novatech Project #: 124147
Project Name: 3400 Woodroffe Avenue
Date: 11/5/2025
Input By: Lucas Wilson
Reviewed By: Mark Bissett

Building Description: Bldg #3
Wood frame

Step	Input		Value Used	Total Fire Flow (L/min)		
Base Fire Flow						
1	Construction Material		Multiplier	1.5		
	Coefficient related to type of construction C	Wood frame	Yes		1.5	
		Ordinary construction			1	
		Non-combustible construction			0.8	
		Modified Fire resistive construction (2 hrs)			0.6	
Fire resistive construction (> 3 hrs)			0.6			
2	Floor Area			11,000		
	A	Building Footprint (m ²)	345		1,035	
		Number of Floors/Storeys	3			
		Area of structure considered (m ²)				
F	Base fire flow without reductions					
Reductions or Surcharges						
3	Occupancy hazard reduction or surcharge		Reduction/Surcharge	8,250		
	(1)	Non-combustible	Yes		-25%	
		Limited combustible			-15%	
		Combustible			0%	
		Free burning			15%	
Rapid burning			25%			
4	Sprinkler Reduction		Reduction	0		
	(2)	Adequately Designed System (NFPA 13)			-30%	
		Standard Water Supply			-10%	
		Fully Supervised System			-10%	
Cumulative Total			0%			
5	Exposure Surcharge (cumulative %)		Surcharge	2,888		
	(3)	North Side	> 45.1m		0%	
		East Side	30.1- 45 m		5%	
		South Side	3.1 - 10 m		20%	
		West Side	20.1 - 30 m		10%	
Cumulative Total			35%			
Results						
6	(1) + (2) + (3)	Total Required Fire Flow, rounded to nearest 1000L/min		L/min	11,000	
		(2,000 L/min < Fire Flow < 45,000 L/min)		or	L/s	183
				or	USGPM	2,906
7	Storage Volume	Required Duration of Fire Flow (hours)		Hours	2	
		Required Volume of Fire Flow (m ³)		m ³	1320	

FUS - Fire Flow Calculations

As per 1999 Fire Underwriter's Survey Guidelines



Engineers, Planners & Landscape Architects

Novatech Project #: 124147
Project Name: 3400 Woodroffe Avenue
Date: 11/5/2025
Input By: Lucas Wilson
Reviewed By: Mark Bissett

Building Description: Bldg #4 & 5
Wood frame

Step	Input		Value Used	Total Fire Flow (L/min)		
Base Fire Flow						
1	Construction Material		Multiplier	1.5		
	Coefficient related to type of construction C	Wood frame	Yes		1.5	
		Ordinary construction			1	
		Non-combustible construction			0.8	
		Modified Fire resistive construction (2 hrs)			0.6	
Fire resistive construction (> 3 hrs)			0.6			
2	Floor Area			11,000		
	A	Building Footprint (m ²)	345		1,035	
		Number of Floors/Storeys	3			
		Area of structure considered (m ²)				
F	Base fire flow without reductions					
Reductions or Surcharges						
3	Occupancy hazard reduction or surcharge		Reduction/Surcharge	8,250		
	(1)	Non-combustible	Yes		-25%	
		Limited combustible			-15%	
		Combustible			0%	
		Free burning			15%	
Rapid burning			25%			
4	Sprinkler Reduction		Reduction	0		
	(2)	Adequately Designed System (NFPA 13)			-30%	
		Standard Water Supply			-10%	
		Fully Supervised System			-10%	
Cumulative Total			0%			
5	Exposure Surcharge (cumulative %)		Surcharge	3,713		
	(3)	North Side	3.1 - 10 m		20%	
		East Side	30.1 - 45 m		5%	
		South Side	20.1 - 30 m		10%	
		West Side	20.1 - 30 m		10%	
Cumulative Total			45%			
Results						
6	(1) + (2) + (3)	Total Required Fire Flow, rounded to nearest 1000L/min		L/min	12,000	
		(2,000 L/min < Fire Flow < 45,000 L/min)		or	L/s	200
				or	USGPM	3,170
7	Storage Volume	Required Duration of Fire Flow (hours)		Hours	2.5	
		Required Volume of Fire Flow (m ³)		m ³	1800	

FUS - Fire Flow Calculations

As per 1999 Fire Underwriter's Survey Guidelines



Engineers, Planners & Landscape Architects

Novatech Project #: 124147
Project Name: 3400 Woodroffe Avenue
Date: 11/5/2025
Input By: Lucas Wilson
Reviewed By: Mark Bissett

Building Description: Bldg #6
Wood frame

Step	Input		Value Used	Total Fire Flow (L/min)		
Base Fire Flow						
1	Construction Material		Multiplier	1.5		
	Coefficient related to type of construction C	Wood frame	Yes		1.5	
		Ordinary construction			1	
		Non-combustible construction			0.8	
		Modified Fire resistive construction (2 hrs)			0.6	
Fire resistive construction (> 3 hrs)			0.6			
2	Floor Area			11,000		
	A	Building Footprint (m ²)	345		1,035	
		Number of Floors/Storeys	3			
		Area of structure considered (m ²)				
F	Base fire flow without reductions					
Reductions or Surcharges						
3	Occupancy hazard reduction or surcharge		Reduction/Surcharge	8,250		
	(1)	Non-combustible	Yes		-25%	
		Limited combustible			-15%	
		Combustible			0%	
		Free burning			15%	
Rapid burning			25%			
4	Sprinkler Reduction		Reduction	0		
	(2)	Adequately Designed System (NFPA 13)			-30%	
		Standard Water Supply			-10%	
		Fully Supervised System			-10%	
Cumulative Total			0%			
5	Exposure Surcharge (cumulative %)		Surcharge	4,125		
	(3)	North Side	3.1 - 10 m		20%	
		East Side	30.1 - 45 m		5%	
		South Side	10.1 - 20 m		15%	
		West Side	20.1 - 30 m		10%	
Cumulative Total			50%			
Results						
6	(1) + (2) + (3)	Total Required Fire Flow, rounded to nearest 1000L/min		L/min	12,000	
		(2,000 L/min < Fire Flow < 45,000 L/min)		or	L/s	200
				or	USGPM	3,170
7	Storage Volume	Required Duration of Fire Flow (hours)		Hours	2.5	
		Required Volume of Fire Flow (m ³)		m ³	1800	

FUS - Fire Flow Calculations

As per 1999 Fire Underwriter's Survey Guidelines



Engineers, Planners & Landscape Architects

Novatech Project #: 124147
Project Name: 3400 Woodroffe Avenue
Date: 11/5/2025
Input By: Lucas Wilson
Reviewed By: Mark Bissett

Building Description: Bldg #7
Wood frame

Step	Input		Value Used	Total Fire Flow (L/min)		
Base Fire Flow						
1	Construction Material		Multiplier	1.5		
	Coefficient related to type of construction C	Wood frame	Yes		1.5	
		Ordinary construction			1	
		Non-combustible construction			0.8	
		Modified Fire resistive construction (2 hrs)			0.6	
Fire resistive construction (> 3 hrs)			0.6			
2	Floor Area		1,035	11,000		
	A	Building Footprint (m ²)			345	
		Number of Floors/Storeys			3	
		Area of structure considered (m ²)				
F	Base fire flow without reductions		$F = 220 C (A)^{0.5}$			
Reductions or Surcharges						
3	Occupancy hazard reduction or surcharge		Reduction/Surcharge	8,250		
	(1)	Non-combustible	Yes		-25%	
		Limited combustible			-15%	
		Combustible			0%	
		Free burning			15%	
Rapid burning			25%			
4	Sprinkler Reduction		Reduction	0		
	(2)	Adequately Designed System (NFPA 13)			-30%	
		Standard Water Supply			-10%	
		Fully Supervised System			-10%	
Cumulative Total			0%			
5	Exposure Surcharge (cumulative %)		Surcharge	4,538		
	(3)	North Side	3.1 - 10 m		20%	
		East Side	30.1 - 45 m		5%	
		South Side	10.1 - 20 m		15%	
		West Side	10.1 - 20 m		15%	
Cumulative Total			55%			
Results						
6	(1) + (2) + (3)	Total Required Fire Flow, rounded to nearest 1000L/min		L/min	13,000	
		(2,000 L/min < Fire Flow < 45,000 L/min)		or	L/s	217
				or	USGPM	3,435
7	Storage Volume	Required Duration of Fire Flow (hours)		Hours	2.5	
		Required Volume of Fire Flow (m ³)		m ³	1950	

FUS - Fire Flow Calculations

As per 1999 Fire Underwriter's Survey Guidelines



Engineers, Planners & Landscape Architects

Novatech Project #: 124147
 Project Name: 3400 Woodroffe Avenue
 Date: 11/5/2025
 Input By: Lucas Wilson
 Reviewed By: Mark Bissett

Building Description: Bldg #8 & 9
 Wood frame

Step	Input		Value Used	Total Fire Flow (L/min)		
Base Fire Flow						
1	Construction Material		Multiplier	1.5		
	Coefficient related to type of construction C	Wood frame	Yes		1.5	
		Ordinary construction			1	
		Non-combustible construction			0.8	
		Modified Fire resistive construction (2 hrs)			0.6	
Fire resistive construction (> 3 hrs)			0.6			
2	Floor Area			11,000		
	A	Building Footprint (m ²)	345		1,035	
		Number of Floors/Storeys	3			
		Area of structure considered (m ²)				
F	Base fire flow without reductions					
Reductions or Surcharges						
3	Occupancy hazard reduction or surcharge		Reduction/Surcharge	8,250		
	(1)	Non-combustible	Yes		-25%	
		Limited combustible			-15%	
		Combustible			0%	
		Free burning			15%	
Rapid burning			25%			
4	Sprinkler Reduction		Reduction	0		
	(2)	Adequately Designed System (NFPA 13)			-30%	
		Standard Water Supply			-10%	
		Fully Supervised System			-10%	
Cumulative Total			0%			
5	Exposure Surcharge (cumulative %)		Surcharge	4,950		
	(3)	North Side	10.1 - 20 m		15%	
		East Side	10.1 - 20 m		15%	
		South Side	20.1 - 30 m		10%	
		West Side	3.1 - 10 m		20%	
Cumulative Total			60%			
Results						
6	(1) + (2) + (3)	Total Required Fire Flow, rounded to nearest 1000L/min		L/min	13,000	
		(2,000 L/min < Fire Flow < 45,000 L/min)		or	L/s	217
				or	USGPM	3,435
7	Storage Volume	Required Duration of Fire Flow (hours)		Hours	2.5	
		Required Volume of Fire Flow (m ³)		m ³	1950	

FUS - Fire Flow Calculations

As per 1999 Fire Underwriter's Survey Guidelines



Engineers, Planners & Landscape Architects

Novatech Project #: 124147
Project Name: 3400 Woodroffe Avenue
Date: 11/5/2025
Input By: Lucas Wilson
Reviewed By: Mark Bissett

Building Description: Bldg #10 & 11
Wood frame

Step	Input		Value Used	Total Fire Flow (L/min)		
Base Fire Flow						
1	Construction Material		Multiplier	1.5		
	Coefficient related to type of construction C	Wood frame	Yes		1.5	
		Ordinary construction			1	
		Non-combustible construction			0.8	
		Modified Fire resistive construction (2 hrs)			0.6	
Fire resistive construction (> 3 hrs)			0.6			
2	Floor Area			12,000		
	A	Building Footprint (m ²)	456		1,368	
		Number of Floors/Storeys	3			
		Area of structure considered (m ²)				
	F	Base fire flow without reductions				
$F = 220 C (A)^{0.5}$						
Reductions or Surcharges						
3	Occupancy hazard reduction or surcharge		Reduction/Surcharge	10,200		
	(1)	Non-combustible			-25%	
		Limited combustible	Yes		-15%	
		Combustible			0%	
		Free burning			15%	
Rapid burning			25%			
4	Sprinkler Reduction		Reduction	0		
	(2)	Adequately Designed System (NFPA 13)			-30%	
		Standard Water Supply			-10%	
		Fully Supervised System			-10%	
Cumulative Total			0%			
5	Exposure Surcharge (cumulative %)		Surcharge	5,610		
	(3)	North Side	20.1 - 30 m		10%	
		East Side	20.1 - 30 m		10%	
		South Side	3.1 - 10 m		20%	
		West Side	10.1 - 20 m		15%	
Cumulative Total			55%			
Results						
6	(1) + (2) + (3)	Total Required Fire Flow, rounded to nearest 1000L/min		L/min	16,000	
		(2,000 L/min < Fire Flow < 45,000 L/min)		or	L/s	267
				or	USGPM	4,227
7	Storage Volume	Required Duration of Fire Flow (hours)		Hours	3.5	
		Required Volume of Fire Flow (m ³)		m³	3360	

FUS - Fire Flow Calculations

As per 1999 Fire Underwriter's Survey Guidelines



Engineers, Planners & Landscape Architects

Novatech Project #: 124147
Project Name: 3400 Woodroffe Avenue
Date: 11/5/2025
Input By: Lucas Wilson
Reviewed By: Mark Bissett

Building Description: Bldg #12 (2hr Firewall)
Wood frame

Step	Input		Value Used	Total Fire Flow (L/min)		
Base Fire Flow						
1	Construction Material		Multiplier	1.5		
	Coefficient related to type of construction C	Wood frame	Yes		1.5	
		Ordinary construction			1	
		Non-combustible construction			0.8	
		Modified Fire resistive construction (2 hrs)			0.6	
Fire resistive construction (> 3 hrs)			0.6			
2	Floor Area		910	10,000		
	A	Building Footprint (m ²)			455	
		Number of Floors/Storeys			2	
		Area of structure considered (m ²)				
F	Base fire flow without reductions		F = 220 C (A)^{0.5}			
Reductions or Surcharges						
3	Occupancy hazard reduction or surcharge		Reduction/Surcharge	8,500		
	(1)	Non-combustible			-25%	
		Limited combustible	Yes		-15%	
		Combustible			0%	
		Free burning			15%	
Rapid burning			25%			
4	Sprinkler Reduction		Reduction	0		
	(2)	Adequately Designed System (NFPA 13)			-30%	
		Standard Water Supply			-10%	
		Fully Supervised System			-10%	
Cumulative Total			0%			
5	Exposure Surcharge (cumulative %)		Surcharge	4,250		
	(3)	North Side	20.1 - 30 m		10%	
		East Side	10.1 - 20 m		15%	
		South Side	2Hr Fire Wall		10%	
		West Side	10.1 - 20 m		15%	
Cumulative Total			50%			
Results						
6	(1) + (2) + (3)	Total Required Fire Flow, rounded to nearest 1000L/min		L/min	13,000	
		(2,000 L/min < Fire Flow < 45,000 L/min)		or	L/s	217
				or	USGPM	3,435
7	Storage Volume	Required Duration of Fire Flow (hours)		Hours	2.5	
		Required Volume of Fire Flow (m ³)		m ³	1950	

FUS - Fire Flow Calculations

As per 1999 Fire Underwriter's Survey Guidelines



Engineers, Planners & Landscape Architects

Novatech Project #: 124147
Project Name: 3400 Woodroffe Avenue
Date: 11/5/2025
Input By: Lucas Wilson
Reviewed By: Mark Bissett

Building Description: Bldg #13 & 16
Wood frame

Step	Input		Value Used	Total Fire Flow (L/min)		
Base Fire Flow						
1	Construction Material		Multiplier	1.5		
	Coefficient related to type of construction C	Wood frame	Yes		1.5	
		Ordinary construction			1	
		Non-combustible construction			0.8	
		Modified Fire resistive construction (2 hrs)			0.6	
Fire resistive construction (> 3 hrs)			0.6			
2	Floor Area			11,000		
	A	Building Footprint (m ²)	533		1,066	
		Number of Floors/Storeys	2			
		Area of structure considered (m ²)				
F	Base fire flow without reductions					
Reductions or Surcharges						
3	Occupancy hazard reduction or surcharge		Reduction/Surcharge	9,350		
	(1)	Non-combustible			-25%	
		Limited combustible	Yes		-15%	
		Combustible			0%	
		Free burning			15%	
Rapid burning			25%			
4	Sprinkler Reduction		Reduction	0		
	(2)	Adequately Designed System (NFPA 13)			-30%	
		Standard Water Supply			-10%	
		Fully Supervised System			-10%	
Cumulative Total			0%			
5	Exposure Surcharge (cumulative %)		Surcharge	4,208		
	(3)	North Side	3.1 - 10 m		20%	
		East Side	10.1 - 20 m		15%	
		South Side	20.1 - 30 m		10%	
		West Side	> 45.1m		0%	
Cumulative Total			45%			
Results						
6	(1) + (2) + (3)	Total Required Fire Flow, rounded to nearest 1000L/min		L/min	14,000	
		(2,000 L/min < Fire Flow < 45,000 L/min)		or	L/s	233
				or	USGPM	3,699
7	Storage Volume	Required Duration of Fire Flow (hours)		Hours	3	
		Required Volume of Fire Flow (m ³)		m ³	2520	

FUS - Fire Flow Calculations

As per 1999 Fire Underwriter's Survey Guidelines



Engineers, Planners & Landscape Architects

Novatech Project #: 124147
Project Name: 3400 Woodroffe Avenue
Date: 11/5/2025
Input By: Lucas Wilson
Reviewed By: Mark Bissett

Building Description: Bldg #14 & 15
Wood frame

Step	Input		Value Used	Total Fire Flow (L/min)		
Base Fire Flow						
1	Construction Material		Multiplier	1.5		
	Coefficient related to type of construction C	Wood frame	Yes		1.5	
		Ordinary construction			1	
		Non-combustible construction			0.8	
		Modified Fire resistive construction (2 hrs)			0.6	
Fire resistive construction (> 3 hrs)			0.6			
2	Floor Area		716	9,000		
	A	Building Footprint (m ²)			358	
		Number of Floors/Storeys			2	
		Area of structure considered (m ²)				
F	Base fire flow without reductions					
Reductions or Surcharges						
3	Occupancy hazard reduction or surcharge		Reduction/Surcharge	7,650		
	(1)	Non-combustible			-25%	
		Limited combustible	Yes		-15%	
		Combustible			0%	
		Free burning			15%	
Rapid burning			25%			
4	Sprinkler Reduction		Reduction	0		
	(2)	Adequately Designed System (NFPA 13)			-30%	
		Standard Water Supply			-10%	
		Fully Supervised System			-10%	
Cumulative Total			0%			
5	Exposure Surcharge (cumulative %)		Surcharge	4,208		
	(3)	North Side	3.1 - 10 m		20%	
		East Side	10.1 - 20 m		15%	
		South Side	3.1 - 10 m		20%	
		West Side	> 45.1m		0%	
Cumulative Total			55%			
Results						
6	(1) + (2) + (3)	Total Required Fire Flow, rounded to nearest 1000L/min		L/min	12,000	
		(2,000 L/min < Fire Flow < 45,000 L/min)		or	L/s	200
				or	USGPM	3,170
7	Storage Volume	Required Duration of Fire Flow (hours)		Hours	2.5	
		Required Volume of Fire Flow (m ³)		m ³	1800	

OBC Water Supply for Firefighting Calculation

Based on OBC 2012 (Div. B, Article 3.2.5.7)

References: [Ontario Fire Marshal - OBC Fire Fighting Water Supply](#)
[Ontario Building Code 2012, Appendix A, Vol 2., A-3.2.5.7](#)

Novatech Project #: 124147
 Project Name: 3400 Woodroffe Avenue
 Date: 9/22/2025
 Input By: Lucas Wilson
 Reviewed By: Mark Bissett

Building Description: Terra Flats (Building # 1 to # 9)
 Unsprinklered

Step	Calculation Inputs	Calculation Notes	Value
Minimum Fire Protection Water Supply Volume			
1	Water Supply Coefficient		
	Building Classification = Water Supply Coefficient - K =	C, D From Table 3.1.2.1 From Table 1 (A3.2.5.7)	23
2	Total Building Volume		
	Building Width - W	19.00 m	Area (W * L) = 380 m
	Building Length - L	20.00 m	
	Building Height - H	9 m	
Total Building Volume - V =		W * L * H	3420 m³
3	Spatial Coefficient Value		
	Exposure Distances: (Exterior building face to property/lot line, to street centre, or to mid-point between proposed building and another building on same lot)		Spatial Coefficients: From Figure 1 (Spatial Coefficient vs Exposure Distance)
	North	2.50 m	Sside 1 = 0.50
	East	9.40 m	Sside 2 = 0.06
	South	2.50 m	Sside 3 = 0.50
West	13.20 m	Sside 4 = 0.00	
	Total of Spatial Coefficient Values - S-Tot as obtained from the formula =	1.0 + (Sside 1 + Sside 2 + Sside 3 + Sside 4) (Max. value = 2.0)	2.00
4	Minimum Fire Protection Water Supply Volume		
	Q =	$K * V * S_{Tot}$	157,320 L
Required Minimum Water Supply Flow Rate			
5	Minimum Water Supply Flow Rate =	From Table 2 (For water supply from a municipal or industrial water supply system, min. pressure is 140 kPa)	4,500 L/min or 75 L/s
Minimum Fire Protection Water Supply Volume for 30 minutes			
6	Q =	= Minimum Water Supply Flow Rate (L/min) * 30 minutes	135,000 L
Required Fire Protection Water Supply Volume			
7	Q =	Highest volume out of (4) and (6)	157,320 L
Notes			

OBC Water Supply for Firefighting Calculation

Based on OBC 2012 (Div. B, Article 3.2.5.7)

References: [Ontario Fire Marshal - OBC Fire Fighting Water Supply](#)
[Ontario Building Code 2012, Appendix A, Vol 2., A-3.2.5.7](#)

Novatech Project #: 124147
 Project Name: 3400 Woodroffe Avenue
 Date: 9/22/2025
 Input By: Lucas Wilson
 Reviewed By: Mark Bissett

Building Description: Building #12 - 16-unit Back-to-Back Town (2hr Fire Wall)
 Unsprinklered

Step	Calculation Inputs	Calculation Notes	Value
Minimum Fire Protection Water Supply Volume			
Water Supply Coefficient			
1	Building Classification = Water Supply Coefficient - K =	C, D From Table 3.1.2.1 From Table 1 (A3.2.5.7)	23
Total Building Volume			
2	Building Width - W	24.50 m	Area (W * L) = 456 m W * L * H
	Building Length - L	18.60 m	
	Building Height - H	8.6 m	
	Total Building Volume - V =		3919 m³
Spatial Coefficient Value			
3	Exposure Distances: (Exterior building face to property/lot line, to street centre, or to mid-point between proposed building and another building on same lot)		Spatial Coefficients: From Figure 1 (Spatial Coefficient vs Exposure Distance)
	North	8.90 m	Sside 1 = 0.11
	East	7.70 m	Sside 2 = 0.23
	South	0.00 m	Sside 3 = 0.50
	West	7.70 m	Sside 4 = 0.23
	Total of Spatial Coefficient Values - S-Tot as obtained from the formula =	1.0 + (Sside 1 + Sside 2 + Sside 3 + Sside 4) (Max. value = 2.0)	2.00
Minimum Fire Protection Water Supply Volume			
4	Q =	$K * V * S_{Tot}$	180,275 L
Required Minimum Water Supply Flow Rate			
5	Minimum Water Supply Flow Rate =	From Table 2 (For water supply from a municipal or industrial water supply system, min. pressure is 140 kPa)	5,400 L/min or 90 L/s
Minimum Fire Protection Water Supply Volume for 30 minutes			
6	Q =	= Minimum Water Supply Flow Rate (L/min) * 30 minutes	162,000 L
Required Fire Protection Water Supply Volume			
7	Q =	Highest volume out of (4) and (6)	180,275 L
Notes			

OBC Water Supply for Firefighting Calculation

Based on OBC 2012 (Div. B, Article 3.2.5.7)

References: [Ontario Fire Marshal - OBC Fire Fighting Water Supply](#)
[Ontario Building Code 2012, Appendix A, Vol 2., A-3.2.5.7](#)

Novatech Project #: 124147
 Project Name: 3400 Woodroffe Avenue
 Date: 9/22/2025
 Input By: Lucas Wilson
 Reviewed By: Mark Bissett

Building Description: Building #13 - 6-unit Town
 Unsprinklered

Step	Calculation Inputs	Calculation Notes	Value	
Minimum Fire Protection Water Supply Volume				
1	Water Supply Coefficient			
	Building Classification = Water Supply Coefficient - K =	C, D From Table 3.1.2.1 From Table 1 (A3.2.5.7)	23	
2	Total Building Volume			
	Building Width - W	24.40 m	Area (W * L) = 356 m	
	Building Length - L	14.60 m		
	Building Height - H	8.2 m		
Total Building Volume - V =		W * L * H	2921 m³	
3	Spatial Coefficient Value			
	Exposure Distances: (Exterior building face to property/lot line, to street centre, or to mid-point between proposed building and another building on same lot)		Spatial Coefficients: From Figure 1 (Spatial Coefficient vs Exposure Distance)	
	North	1.80 m	Sside 1 = 0.50	
	East	8.20 m	Sside 2 = 0.18	
	South	0.00 m	Sside 3 = 0.50	
West	21.30 m	Sside 4 = 0.00		
Total of Spatial Coefficient Values - S-Tot as obtained from the formula =		1.0 + (Sside 1 + Sside 2 + Sside 3 + Sside 4) (Max. value = 2.0)	2.00	
4	Minimum Fire Protection Water Supply Volume			
	Q =		K * V * S_{Tot}	134,374 L
Required Minimum Water Supply Flow Rate				
5	Minimum Water Supply Flow Rate =		From Table 2 (For water supply from a municipal or industrial water supply system, min. pressure is 140 kPa)	3,600 L/min or 60 L/s
Minimum Fire Protection Water Supply Volume for 30 minutes				
6	Q =		= Minimum Water Supply Flow Rate (L/min) * 30 minutes	108,000 L
Required Fire Protection Water Supply Volume				
7	Q =		Highest volume out of (4) and (6)	134,374 L
Notes				

**3400 Woodroffe Avenue
Water Demand**

	Area (ha)	Units	Population	Average Day Demand (L/s)	Maximum Day Demand (L/s)	Peak Hour Demand (L/s)
Terra Flats	N/A	108	194.4	0.630	1.575	3.465
Towns/Back-to-Back Towns	N/A	52	140.4	0.455	1.138	2.503
Total		160	334.8	1.085	2.713	5.968

Water Demand Parameters

Towns/Back-to-Back Towns	2.7	ppl/unit
Terra Flats	1.8	ppl/unit
Residential Demand	280	L/c/day
Residential Max Day	2.5	x Avg Day
Residential Peak Hour	2.2	x Max Day
Terrace Homes Fire Flow	183 - 267	L/s

3400 Woodroffe Avenue - Watermain Demand

Node	Terra Flats	Towns	Total Population	Total Average Day Demand (L/s)	Maximum Day Residential Demand (L/s)	Peak Hour Residential Demand (L/s)	Fire Flow (L/s)
CAP1	12		22	0.070	0.175	0.385	N/A
CAP2	6		11	0.035	0.088	0.193	N/A
CAP3	12		22	0.070	0.175	0.385	N/A
CAP4	6	4	22	0.070	0.175	0.385	N/A
CAP5	6	4	22	0.070	0.175	0.385	N/A
CAP6	12		22	0.070	0.175	0.385	N/A
CAP7	12		22	0.070	0.175	0.385	N/A
CAP8	12		22	0.070	0.175	0.385	N/A
HYD1			0	0.000	0.000	0.000	267
HYD2			0	0.000	0.000	0.000	233
HYD3			0	0.000	0.000	0.000	233
HYD4			0	0.000	0.000	0.000	267
N1	12		22	0.070	0.175	0.385	N/A
N2	6		11	0.035	0.088	0.193	N/A
RED1			0	0.000	0.000	0.000	N/A
T1		4	11	0.035	0.088	0.193	N/A
T2			0	0.000	0.000	0.000	N/A
T3	6		11	0.035	0.088	0.193	N/A
T4		8	22	0.070	0.175	0.385	N/A
T5			0	0.000	0.000	0.000	N/A
T6		10	27	0.088	0.219	0.481	N/A
T7		10	27	0.088	0.219	0.481	N/A
T8			0	0.000	0.000	0.000	N/A
T9		8	22	0.070	0.175	0.385	N/A
T10			0	0.000	0.000	0.000	N/A
T11		4	11	0.035	0.088	0.193	N/A
T12	6		11	0.035	0.088	0.193	N/A
Total	108	52	335	1.085	2.713	5.968	

Water Demand Parameters

Terra Flats	1.8	ppl/unit	Residential Max Day	2.5	x Avg Day
Towns	2.7	ppl/unit	Residential Peak Hour	2.2	x Max Day
Residential Demand	280	L/c/day	Fire Flow	183 to 267	L/s

3400 Woodroffe Avenue - Watermain Analysis

Pre-SUC Pressure Zone Reconfiguration

Network Table - Nodes - (Peak Hour)

Node ID	Elevation m	Demand LPS	Head m	Pressure m	Pressure kPa	Pressure psi
Junc CAP1	104.1	0.38	141.99	37.9	371.80	53.92
Junc CAP2	104.05	0.19	141.99	37.94	372.19	53.98
Junc CAP3	104.06	0.38	141.99	37.93	372.09	53.97
Junc CAP4	103.72	0.38	141.99	38.27	375.43	54.45
Junc CAP5	103.74	0.38	141.99	38.25	375.23	54.42
Junc CAP6	104.17	0.38	141.99	37.82	371.01	53.81
Junc CAP7	104.1	0.38	141.99	37.89	371.70	53.91
Junc CAP8	104.17	0.38	141.99	37.82	371.01	53.81
Junc HYD1	103.85	0	141.99	38.14	374.15	54.27
Junc HYD2	103.86	0	141.99	38.13	374.06	54.25
Junc HYD3	103.88	0	141.99	38.11	373.86	54.22
Junc HYD4	103.84	0	141.99	38.15	374.25	54.28
Junc N1	103.11	0.38	142	38.89	381.51	55.33
Junc N2	103.64	0.19	142	38.36	376.31	54.58
Junc RED1	103.65	0	141.99	38.34	376.12	54.55
Junc T1	103.74	0.19	141.99	38.25	375.23	54.42
Junc T2	103.69	0	141.99	38.3	375.72	54.49
Junc T3	103.7	0.19	141.99	38.29	375.62	54.48
Junc T4	103.83	0.38	141.99	38.16	374.35	54.29
Junc T5	103.81	0	141.99	38.18	374.55	54.32
Junc T6	103.88	0.48	141.99	38.11	373.86	54.22
Junc T7	103.91	0.48	141.99	38.08	373.56	54.18
Junc T8	103.88	0	141.99	38.11	373.86	54.22
Junc T9	103.87	0.38	141.99	38.12	373.96	54.24
Junc T10	103.86	0	141.99	38.13	374.06	54.25
Junc T11	103.85	0.19	141.99	38.14	374.15	54.27
Junc T12	103.8	0.19	141.99	38.19	374.64	54.34
Resvr RES1	142	-3.29	142	0	0.00	0.00
Resvr RES2	142	-2.63	142	0	0.00	0.00

Network Table - Links - (Peak Hour)

Link ID	Length m	Diameter mm	Roughness	Flow LPS	Velocity m/s	Headloss m/km	Friction Factor
Pipe P1	36	200	110	3.29	0.10	0.11	0.041
Pipe P2	25	200	110	2.90	0.09	0.09	0.041
Pipe P3	17	200	110	2.05	0.07	0.05	0.043
Pipe P4	18	200	110	0.77	0.02	0.01	0.053
Pipe P5	27	100	100	0.38	0.05	0.07	0.061
Pipe P6	7	200	110	0.19	0.01	0.00	0.000
Pipe P7	36	100	100	0.19	0.02	0.02	0.068
Pipe P8	7	200	110	1.28	0.04	0.02	0.050
Pipe P9	29	200	110	1.28	0.04	0.02	0.046
Pipe P10	62	200	110	-0.23	0.01	0.00	0.056
Pipe P11	7	200	110	1.12	0.04	0.02	0.050
Pipe P12	28	100	100	0.38	0.05	0.07	0.061
Pipe P13	20	200	110	0.74	0.02	0.01	0.049
Pipe P14	4	200	110	0.74	0.02	0.01	0.057
Pipe P15	30	100	100	0.38	0.05	0.07	0.061
Pipe P16	68	200	110	-0.08	0.00	0.00	0.079
Pipe P17	30	100	100	0.38	0.05	0.07	0.061
Pipe P18	2	200	110	-0.95	0.03	0.01	0.050
Pipe P19	24	200	110	-0.95	0.03	0.01	0.049
Pipe P20	27	100	100	0.38	0.05	0.07	0.061
Pipe P21	1	200	110	-1.33	0.04	0.02	0.047
Pipe P22	29	200	110	-1.95	0.06	0.04	0.044
Pipe P23	6	200	110	-0.08	0.00	0.00	0.000
Pipe P24	27	100	100	0.38	0.05	0.07	0.061
Pipe P25	39	200	110	-0.66	0.02	0.01	0.052
Pipe P26	7	200	110	-1.86	0.06	0.04	0.044
Pipe P27	13	200	110	-1.86	0.06	0.04	0.044
Pipe P28	27	100	100	0.38	0.05	0.07	0.061
Pipe P29	48	200	110	-2.44	0.08	0.07	0.042
Pipe P30	35	200	110	-2.63	0.08	0.08	0.042

3400 Woodroffe Avenue - Watermain Analysis

Post-SUC Pressure Zone Reconfiguration

Network Table - Nodes - (Peak Hour)

Node ID	Elevation m	Demand LPS	Head m	Pressure m	Pressure kPa	Pressure psi
Junc CAP1	104.1	0.38	143.49	39.4	386.51	56.06
Junc CAP2	104.05	0.19	143.49	39.44	386.91	56.12
Junc CAP3	104.06	0.38	143.49	39.43	386.81	56.10
Junc CAP4	103.72	0.38	143.49	39.77	390.14	56.59
Junc CAP5	103.74	0.38	143.49	39.75	389.95	56.56
Junc CAP6	104.17	0.38	143.49	39.32	385.73	55.95
Junc CAP7	104.1	0.38	143.49	39.39	386.42	56.04
Junc CAP8	104.17	0.38	143.49	39.32	385.73	55.95
Junc HYD1	103.85	0	143.49	39.64	388.87	56.40
Junc HYD2	103.86	0	143.49	39.63	388.77	56.39
Junc HYD3	103.88	0	143.49	39.61	388.57	56.36
Junc HYD4	103.84	0	143.49	39.65	388.97	56.41
Junc N1	103.11	0.38	143.5	40.39	396.23	57.47
Junc N2	103.64	0.19	143.5	39.86	391.03	56.71
Junc RED1	103.65	0	143.49	39.84	390.83	56.69
Junc T1	103.74	0.19	143.49	39.75	389.95	56.56
Junc T2	103.69	0	143.49	39.8	390.44	56.63
Junc T3	103.7	0.19	143.49	39.79	390.34	56.61
Junc T4	103.83	0.38	143.49	39.66	389.06	56.43
Junc T5	103.81	0	143.49	39.68	389.26	56.46
Junc T6	103.88	0.48	143.49	39.61	388.57	56.36
Junc T7	103.91	0.48	143.49	39.58	388.28	56.32
Junc T8	103.88	0	143.49	39.61	388.57	56.36
Junc T9	103.87	0.38	143.49	39.62	388.67	56.37
Junc T10	103.86	0	143.49	39.63	388.77	56.39
Junc T11	103.85	0.19	143.49	39.64	388.87	56.40
Junc T12	103.8	0.19	143.49	39.69	389.36	56.47
Resvr RES1	143.5	-3.29	143.5	0	0.00	0.00
Resvr RES2	143.5	-2.63	143.5	0	0.00	0.00

Network Table - Links - (Peak Hour)

Link ID	Length m	Diameter mm	Roughness	Flow LPS	Velocity m/s	Headloss m/km	Friction Factor
Pipe P1	36	200	110	3.29	0.10	0.11	0.041
Pipe P2	25	200	110	2.90	0.09	0.09	0.041
Pipe P3	17	200	110	2.05	0.07	0.05	0.044
Pipe P4	18	200	110	0.77	0.02	0.01	0.049
Pipe P5	27	100	100	0.38	0.05	0.07	0.061
Pipe P6	7	200	110	0.19	0.01	0.00	0.000
Pipe P7	36	100	100	0.19	0.02	0.02	0.068
Pipe P8	7	200	110	1.28	0.04	0.02	0.047
Pipe P9	29	200	110	1.28	0.04	0.02	0.046
Pipe P10	62	200	110	-0.23	0.01	0.00	0.056
Pipe P11	7	200	110	1.12	0.04	0.02	0.050
Pipe P12	28	100	100	0.38	0.05	0.07	0.061
Pipe P13	20	200	110	0.74	0.02	0.01	0.049
Pipe P14	4	200	110	0.74	0.02	0.01	0.057
Pipe P15	30	100	100	0.38	0.05	0.07	0.061
Pipe P16	68	200	110	-0.08	0.00	0.00	0.079
Pipe P17	30	100	100	0.38	0.05	0.07	0.061
Pipe P18	2	200	110	-0.95	0.03	0.01	0.050
Pipe P19	24	200	110	-0.95	0.03	0.01	0.049
Pipe P20	27	100	100	0.38	0.05	0.07	0.061
Pipe P21	1	200	110	-1.33	0.04	0.02	0.047
Pipe P22	29	200	110	-1.95	0.06	0.04	0.044
Pipe P23	6	200	110	-0.08	0.00	0.00	0.000
Pipe P24	27	100	100	0.38	0.05	0.07	0.061
Pipe P25	39	200	110	-0.66	0.02	0.01	0.052
Pipe P26	7	200	110	-1.86	0.06	0.04	0.044
Pipe P27	13	200	110	-1.86	0.06	0.04	0.044
Pipe P28	27	100	100	0.38	0.05	0.07	0.061
Pipe P29	48	200	110	-2.44	0.08	0.07	0.042
Pipe P30	35	200	110	-2.63	0.08	0.08	0.042

3400 Woodroffe Avenue - Watermain Analysis

Pre-SUC Pressure Zone Reconfiguration

Network Table - Nodes - (Max Pressure Check)

Node ID	Elevation m	Demand LPS	Head m	Pressure m	Pressure kPa	Pressure psi	Age Hours
Junc CAP1	104.1	0.07	154.5	50.41	494.52	71.72	3.33
Junc CAP2	104.05	0.04	154.5	50.45	494.91	71.78	6.43
Junc CAP3	104.06	0.07	154.5	50.44	494.82	71.77	5.85
Junc CAP4	103.72	0.07	154.5	50.78	498.15	72.25	11.25
Junc CAP5	103.74	0.07	154.5	50.76	497.96	72.22	5.28
Junc CAP6	104.17	0.07	154.5	50.33	493.74	71.61	3.89
Junc CAP7	104.1	0.07	154.5	50.4	494.42	71.71	2.42
Junc CAP8	104.17	0.07	154.5	50.33	493.74	71.61	4.64
Junc HYD1	103.85	0	154.5	50.65	496.88	72.07	1.61
Junc HYD2	103.86	0	154.5	50.64	496.78	72.05	6.31
Junc HYD3	103.88	0	154.5	50.62	496.58	72.02	4.27
Junc HYD4	103.84	0	154.5	50.66	496.97	72.08	1.9
Junc N1	103.11	0.07	154.5	51.39	504.14	73.12	0.52
Junc N2	103.64	0.04	154.5	50.86	498.94	72.36	0.64
Junc RED1	103.65	0	154.5	50.85	498.84	72.35	4.21
Junc T1	103.74	0.04	154.5	50.76	497.96	72.22	0.94
Junc T2	103.69	0	154.5	50.81	498.45	72.29	1.34
Junc T3	103.7	0.04	154.5	50.8	498.35	72.28	2.49
Junc T4	103.83	0.07	154.5	50.67	497.07	72.09	4.7
Junc T5	103.81	0	154.5	50.69	497.27	72.12	4.99
Junc T6	103.88	0.09	154.5	50.62	496.58	72.02	10.32
Junc T7	103.91	0.09	154.5	50.59	496.29	71.98	4.35
Junc T8	103.88	0	154.5	50.62	496.58	72.02	3.05
Junc T9	103.87	0.07	154.5	50.63	496.68	72.04	3.01
Junc T10	103.86	0	154.5	50.64	496.78	72.05	2.29
Junc T11	103.85	0.04	154.5	50.65	496.88	72.07	3.8
Junc T12	103.8	0.04	154.5	50.7	497.37	72.14	1.58
Resvr RES1	154.5	-0.6	154.5	0	0.00	0.00	0
Resvr RES2	154.5	-0.48	154.5	0	0.00	0.00	0

Network Table - Links - (Max Pressure Check)

Link ID	Length m	Diameter mm	Roughness	Flow LPS	Velocity m/s	Headloss m/km	Friction Factor
Pipe P1	36	200	110	0.60	0.02	0.00	0.054
Pipe P2	25	200	110	0.53	0.02	0.00	0.051
Pipe P3	17	200	110	0.37	0.01	0.00	0.060
Pipe P4	18	200	110	0.14	0.00	0.00	0.000
Pipe P5	27	100	100	0.07	0.01	0.00	0.085
Pipe P6	7	200	110	0.04	0.00	0.00	0.000
Pipe P7	36	100	100	0.04	0.00	0.00	0.103
Pipe P8	7	200	110	0.23	0.01	0.00	0.000
Pipe P9	29	200	110	0.23	0.01	0.00	0.069
Pipe P10	62	200	110	-0.04	0.00	0.00	0.000
Pipe P11	7	200	110	0.20	0.01	0.00	0.000
Pipe P12	28	100	100	0.07	0.01	0.00	0.083
Pipe P13	20	200	110	0.13	0.00	0.00	0.098
Pipe P14	4	200	110	0.13	0.00	0.00	0.000
Pipe P15	30	100	100	0.07	0.01	0.00	0.077
Pipe P16	68	200	110	-0.01	0.00	0.00	0.000
Pipe P17	30	100	100	0.07	0.01	0.00	0.077
Pipe P18	2	200	110	-0.17	0.01	0.00	0.000
Pipe P19	24	200	110	-0.17	0.01	0.00	0.050
Pipe P20	27	100	100	0.07	0.01	0.00	0.077
Pipe P21	1	200	110	-0.24	0.01	0.00	0.000
Pipe P22	29	200	110	-0.35	0.01	0.00	0.060
Pipe P23	6	200	110	-0.02	0.00	0.00	0.000
Pipe P24	27	100	100	0.07	0.01	0.00	0.077
Pipe P25	39	200	110	-0.12	0.00	0.00	0.063
Pipe P26	7	200	110	-0.34	0.01	0.00	0.044
Pipe P27	13	200	110	-0.34	0.01	0.00	0.050
Pipe P28	27	100	100	0.07	0.01	0.00	0.077
Pipe P29	48	200	110	-0.44	0.01	0.00	0.057
Pipe P30	35	200	110	-0.48	0.02	0.00	0.054

3400 Woodroffe Avenue - Watermain Analysis

Post-SUC Pressure Zone Reconfiguration

Network Table - Nodes - (Max Pressure Check)

Node ID	Elevation m	Demand LPS	Head m	Pressure m	Pressure kPa	Pressure psi	Age Hours
Junc CAP1	104.1	0.07	146.9	42.81	419.97	60.91	3.33
Junc CAP2	104.05	0.04	146.9	42.85	420.36	60.97	6.43
Junc CAP3	104.06	0.07	146.9	42.84	420.26	60.95	5.85
Junc CAP4	103.72	0.07	146.9	43.18	423.60	61.44	11.25
Junc CAP5	103.74	0.07	146.9	43.16	423.40	61.41	5.28
Junc CAP6	104.17	0.07	146.9	42.73	419.18	60.80	3.89
Junc CAP7	104.1	0.07	146.9	42.8	419.87	60.90	2.42
Junc CAP8	104.17	0.07	146.9	42.73	419.18	60.80	4.64
Junc HYD1	103.85	0	146.9	43.05	422.32	61.25	1.61
Junc HYD2	103.86	0	146.9	43.04	422.22	61.24	6.31
Junc HYD3	103.88	0	146.9	43.02	422.03	61.21	4.27
Junc HYD4	103.84	0	146.9	43.06	422.42	61.27	1.9
Junc N1	103.11	0.07	146.9	43.79	429.58	62.31	0.52
Junc N2	103.64	0.04	146.9	43.26	424.38	61.55	0.64
Junc RED1	103.65	0	146.9	43.25	424.28	61.54	4.21
Junc T1	103.74	0.04	146.9	43.16	423.40	61.41	0.94
Junc T2	103.69	0	146.9	43.21	423.89	61.48	1.34
Junc T3	103.7	0.04	146.9	43.2	423.79	61.47	2.49
Junc T4	103.83	0.07	146.9	43.07	422.52	61.28	4.7
Junc T5	103.81	0	146.9	43.09	422.71	61.31	4.99
Junc T6	103.88	0.09	146.9	43.02	422.03	61.21	10.32
Junc T7	103.91	0.09	146.9	42.99	421.73	61.17	4.35
Junc T8	103.88	0	146.9	43.02	422.03	61.21	3.05
Junc T9	103.87	0.07	146.9	43.03	422.12	61.22	3.01
Junc T10	103.86	0	146.9	43.04	422.22	61.24	2.29
Junc T11	103.85	0.04	146.9	43.05	422.32	61.25	3.8
Junc T12	103.8	0.04	146.9	43.1	422.81	61.32	1.58
Resvr RES1	146.9	-0.6	146.9	0	0.00	0.00	0
Resvr RES2	146.9	-0.48	146.9	0	0.00	0.00	0

Network Table - Links - (Max Pressure Check)

Link ID	Length m	Diameter mm	Roughness	Flow LPS	Velocity m/s	Headloss m/km	Friction Factor
Pipe P1	36	200	110	0.60	0.02	0.00	0.054
Pipe P2	25	200	110	0.53	0.02	0.00	0.051
Pipe P3	17	200	110	0.37	0.01	0.00	0.060
Pipe P4	18	200	110	0.14	0.00	0.00	0.000
Pipe P5	27	100	100	0.07	0.01	0.00	0.076
Pipe P6	7	200	110	0.04	0.00	0.00	0.000
Pipe P7	36	100	100	0.04	0.00	0.00	0.103
Pipe P8	7	200	110	0.23	0.01	0.00	0.000
Pipe P9	29	200	110	0.23	0.01	0.00	0.069
Pipe P10	62	200	110	-0.04	0.00	0.00	0.000
Pipe P11	7	200	110	0.20	0.01	0.00	0.000
Pipe P12	28	100	100	0.07	0.01	0.00	0.083
Pipe P13	20	200	110	0.13	0.00	0.00	0.098
Pipe P14	4	200	110	0.13	0.00	0.00	0.000
Pipe P15	30	100	100	0.07	0.01	0.00	0.077
Pipe P16	68	200	110	-0.01	0.00	0.00	0.000
Pipe P17	30	100	100	0.07	0.01	0.00	0.077
Pipe P18	2	200	110	-0.17	0.01	0.00	0.000
Pipe P19	24	200	110	-0.17	0.01	0.00	0.050
Pipe P20	27	100	100	0.07	0.01	0.00	0.077
Pipe P21	1	200	110	-0.24	0.01	0.00	0.000
Pipe P22	29	200	110	-0.35	0.01	0.00	0.060
Pipe P23	6	200	110	-0.02	0.00	0.00	0.000
Pipe P24	27	100	100	0.07	0.01	0.00	0.077
Pipe P25	39	200	110	-0.12	0.00	0.00	0.063
Pipe P26	7	200	110	-0.34	0.01	0.00	0.044
Pipe P27	13	200	110	-0.34	0.01	0.00	0.075
Pipe P28	27	100	100	0.07	0.01	0.00	0.085
Pipe P29	48	200	110	-0.44	0.01	0.00	0.054
Pipe P30	35	200	110	-0.48	0.02	0.00	0.054

3400 Woodroffe Avenue - Watermain Analysis

Pre-SUC Pressure Zone Reconfiguration

Network Table - Nodes - (Max Day + FF '267 L/s')

Node ID	Elevation m	Demand LPS	Head m	Pressure m	Pressure kPa	Pressure psi
Junc CAP1	104.1	0.17	125.72	21.63	212.19	30.78
Junc CAP2	104.05	0.09	125.72	21.67	212.58	30.83
Junc CAP3	104.06	0.17	125.06	21	206.01	29.88
Junc CAP4	103.72	0.17	124.8	21.08	206.79	29.99
Junc CAP5	103.74	0.17	125.37	21.63	212.19	30.78
Junc CAP6	104.17	0.17	125.58	21.41	210.03	30.46
Junc CAP7	104.1	0.17	127.49	23.39	229.46	33.28
Junc CAP8	104.17	0.17	126.48	22.31	218.86	31.74
Junc HYD1	103.85	95	125.2	21.35	209.44	30.38
Junc HYD2	103.86	77	124.78	20.92	205.23	29.77
Junc HYD3	103.88	0	125.38	21.5	210.92	30.59
Junc HYD4	103.84	95	126.43	22.59	221.61	32.14
Junc N1	103.11	0.17	130.47	27.36	268.40	38.93
Junc N2	103.64	0.09	131.54	27.9	273.70	39.70
Junc RED1	103.65	0	125.72	22.07	216.51	31.40
Junc T1	103.74	0.09	127	23.26	228.18	33.09
Junc T2	103.69	0	125.72	22.03	216.11	31.34
Junc T3	103.7	0.09	125.72	22.02	216.02	31.33
Junc T4	103.83	0.17	125.15	21.32	209.15	30.33
Junc T5	103.81	0	125.06	21.25	208.46	30.23
Junc T6	103.88	0.22	124.8	20.92	205.23	29.77
Junc T7	103.91	0.22	125.37	21.46	210.52	30.53
Junc T8	103.88	0	125.58	21.7	212.88	30.88
Junc T9	103.87	0.17	125.59	21.72	213.07	30.90
Junc T10	103.86	0	126.41	22.55	221.22	32.08
Junc T11	103.85	0.09	126.48	22.63	222.00	32.20
Junc T12	103.8	0.09	127.49	23.69	232.40	33.71
Resvr RES1	135.37	-152.33	135.37	0	0.00	0.00
Resvr RES2	134.53	-117.37	134.53	0	0.00	0.00

Network Table - Links - (Max Day + FF '267 L/s')

Link ID	Length m	Diameter mm	Roughness	Flow LPS	Velocity m/s	Headloss m/km	Friction Factor
Pipe P1	36	200	110	152.33	4.85	137.58	0.023
Pipe P2	25	200	110	152.15	4.84	137.29	0.023
Pipe P3	17	200	110	109.10	3.47	74.15	0.024
Pipe P4	18	200	110	0.35	0.01	0.00	0.064
Pipe P5	27	100	100	0.17	0.02	0.02	0.068
Pipe P6	7	200	110	0.09	0.00	0.00	0.000
Pipe P7	36	100	100	0.09	0.01	0.00	0.077
Pipe P8	7	200	110	108.75	3.46	73.71	0.024
Pipe P9	29	200	110	13.75	0.44	1.60	0.033
Pipe P10	62	200	110	-30.70	0.98	7.08	0.029
Pipe P11	7	200	110	44.27	1.41	13.96	0.028
Pipe P12	28	100	100	0.17	0.02	0.02	0.068
Pipe P13	20	200	110	44.10	1.40	13.85	0.028
Pipe P14	4	200	110	-32.90	1.05	8.05	0.029
Pipe P15	30	100	100	0.17	0.02	0.02	0.068
Pipe P16	68	200	110	-33.27	1.06	8.22	0.029
Pipe P17	30	100	100	0.17	0.02	0.02	0.069
Pipe P18	2	200	110	-33.67	1.07	8.40	0.029
Pipe P19	24	200	110	-33.67	1.07	8.40	0.029
Pipe P20	27	100	100	0.17	0.02	0.02	0.069
Pipe P21	1	200	110	-33.84	1.08	8.49	0.029
Pipe P22	29	200	110	-64.71	2.06	28.19	0.026
Pipe P23	6	200	110	-42.70	1.36	13.05	0.028
Pipe P24	27	100	100	0.17	0.02	0.02	0.068
Pipe P25	39	200	110	-42.96	1.37	13.20	0.028
Pipe P26	7	200	110	-22.02	0.70	3.83	0.031
Pipe P27	13	200	110	-117.02	3.72	84.42	0.024
Pipe P28	27	100	100	0.17	0.02	0.02	0.069
Pipe P29	48	200	110	-117.28	3.73	84.77	0.024
Pipe P30	35	200	110	-117.37	3.74	84.89	0.024

3400 Woodroffe Avenue - Watermain Analysis

Post-SUC Pressure Zone Reconfiguration

Network Table - Nodes - (Max Day + FF '267 L/s')

Node ID	Elevation m	Demand LPS	Head m	Pressure m	Pressure kPa	Pressure psi
Junc CAP1	104.1	0.17	129.4	25.31	248.29	36.01
Junc CAP2	104.05	0.09	129.4	25.35	248.68	36.07
Junc CAP3	104.06	0.17	128.74	24.68	242.11	35.12
Junc CAP4	103.72	0.17	128.49	24.77	242.99	35.24
Junc CAP5	103.74	0.17	129.05	25.31	248.29	36.01
Junc CAP6	104.17	0.17	129.27	25.1	246.23	35.71
Junc CAP7	104.1	0.17	131.2	27.1	265.85	38.56
Junc CAP8	104.17	0.17	130.17	26	255.06	36.99
Junc HYD1	103.85	95	128.88	25.03	245.54	35.61
Junc HYD2	103.86	77	128.46	24.6	241.33	35.00
Junc HYD3	103.88	0	129.07	25.19	247.11	35.84
Junc HYD4	103.84	95	130.13	26.29	257.90	37.41
Junc N1	103.11	0.17	134.11	31	304.11	44.11
Junc N2	103.64	0.09	135.3	31.66	310.58	45.05
Junc RED1	103.65	0	129.4	25.75	252.61	36.64
Junc T1	103.74	0.09	130.67	26.93	264.18	38.32
Junc T2	103.69	0	129.4	25.71	252.22	36.58
Junc T3	103.7	0.09	129.4	25.7	252.12	36.57
Junc T4	103.83	0.17	128.84	25.01	245.35	35.58
Junc T5	103.81	0	128.74	24.93	244.56	35.47
Junc T6	103.88	0.22	128.49	24.61	241.42	35.02
Junc T7	103.91	0.22	129.05	25.14	246.62	35.77
Junc T8	103.88	0	129.27	25.39	249.08	36.13
Junc T9	103.87	0.17	129.28	25.41	249.27	36.15
Junc T10	103.86	0	130.1	26.24	257.41	37.33
Junc T11	103.85	0.09	130.17	26.32	258.20	37.45
Junc T12	103.8	0.09	131.2	27.4	268.79	38.99
Resvr RES1	138.96	-151.49	138.96	0	0.00	0.00
Resvr RES2	138.33	-118.2	138.33	0	0.00	0.00

Network Table - Links - (Max Day + FF '267 L/s')

Link ID	Length m	Diameter mm	Roughness	Flow LPS	Velocity m/s	Headloss m/km	Friction Factor
Pipe P1	36	200	110	151.49	4.82	136.18	0.023
Pipe P2	25	200	110	151.31	4.82	135.89	0.023
Pipe P3	17	200	110	108.90	3.47	73.90	0.024
Pipe P4	18	200	110	0.35	0.01	0.00	0.064
Pipe P5	27	100	100	0.17	0.02	0.02	0.068
Pipe P6	7	200	110	0.09	0.00	0.00	0.000
Pipe P7	36	100	100	0.09	0.01	0.00	0.077
Pipe P8	7	200	110	108.55	3.46	73.46	0.024
Pipe P9	29	200	110	13.55	0.43	1.56	0.033
Pipe P10	62	200	110	-30.84	0.98	7.14	0.029
Pipe P11	7	200	110	44.21	1.41	13.92	0.028
Pipe P12	28	100	100	0.17	0.02	0.02	0.068
Pipe P13	20	200	110	44.04	1.40	13.82	0.028
Pipe P14	4	200	110	-32.96	1.05	8.08	0.029
Pipe P15	30	100	100	0.17	0.02	0.02	0.068
Pipe P16	68	200	110	-33.33	1.06	8.25	0.029
Pipe P17	30	100	100	0.17	0.02	0.02	0.067
Pipe P18	2	200	110	-33.73	1.07	8.44	0.029
Pipe P19	24	200	110	-33.73	1.07	8.43	0.029
Pipe P20	27	100	100	0.17	0.02	0.02	0.069
Pipe P21	1	200	110	-33.90	1.08	8.51	0.029
Pipe P22	29	200	110	-64.92	2.07	28.35	0.026
Pipe P23	6	200	110	-42.07	1.34	12.69	0.028
Pipe P24	27	100	100	0.17	0.02	0.02	0.068
Pipe P25	39	200	110	-42.33	1.35	12.84	0.028
Pipe P26	7	200	110	-22.85	0.73	4.10	0.030
Pipe P27	13	200	110	-117.85	3.75	85.54	0.024
Pipe P28	27	100	100	0.17	0.02	0.02	0.068
Pipe P29	48	200	110	-118.12	3.76	85.90	0.024
Pipe P30	35	200	110	-118.20	3.76	86.01	0.024

3400 Woodroffe Avenue - Watermain Analysis

Pre-SUC Pressure Zone Reconfiguration

Network Table - Nodes - (Max Day + FF '267L/s')

Node ID	Elevation m	Demand LPS	Head m	Pressure m	Pressure kPa	Pressure psi
Junc CAP1	104.1	0.17	126.24	22.15	217.29	31.52
Junc CAP2	104.05	0.09	126.24	22.19	217.68	31.57
Junc CAP3	104.06	0.17	123.93	19.87	194.92	28.27
Junc CAP4	103.72	0.17	122.79	19.07	187.08	27.13
Junc CAP5	103.74	0.17	122.8	19.06	186.98	27.12
Junc CAP6	104.17	0.17	124.24	20.07	196.89	28.56
Junc CAP7	104.1	0.17	127.3	23.2	227.59	33.01
Junc CAP8	104.17	0.17	126.25	22.08	216.60	31.42
Junc HYD1	103.85	0	125.86	22.01	215.92	31.32
Junc HYD2	103.86	95	122.79	18.93	185.70	26.93
Junc HYD3	103.88	95	122.8	18.92	185.61	26.92
Junc HYD4	103.84	77	126.22	22.38	219.55	31.84
Junc N1	103.11	0.17	130.57	27.46	269.38	39.07
Junc N2	103.64	0.09	131.46	27.82	272.91	39.58
Junc RED1	103.65	0	126.24	22.59	221.61	32.14
Junc T1	103.74	0.09	127.17	23.43	229.85	33.34
Junc T2	103.69	0	126.24	22.55	221.22	32.08
Junc T3	103.7	0.09	126.24	22.54	221.12	32.07
Junc T4	103.83	0.17	124.31	20.48	200.91	29.14
Junc T5	103.81	0	123.93	20.12	197.38	28.63
Junc T6	103.88	0.22	122.79	18.91	185.51	26.91
Junc T7	103.91	0.22	122.8	18.89	185.31	26.88
Junc T8	103.88	0	124.24	20.36	199.73	28.97
Junc T9	103.87	0.17	124.31	20.44	200.52	29.08
Junc T10	103.86	0	126.13	22.27	218.47	31.69
Junc T11	103.85	0.09	126.26	22.41	219.84	31.89
Junc T12	103.8	0.09	127.3	23.5	230.54	33.44
Resvr RES1	135.37	-150.64	135.37	0	0.00	0.00
Resvr RES2	134.53	-119.06	134.53	0	0.00	0.00

Network Table - Links - (Max Day + FF '267L/s')

Link ID	Length m	Diameter mm	Roughness	Flow LPS	Velocity m/s	Headloss m/km	Friction Factor
Pipe P1	36	200	110	150.64	4.79	134.77	0.023
Pipe P2	25	200	110	150.46	4.79	134.48	0.023
Pipe P3	17	200	110	92.10	2.93	54.19	0.025
Pipe P4	18	200	110	0.35	0.01	0.00	0.064
Pipe P5	27	100	100	0.17	0.02	0.02	0.068
Pipe P6	7	200	110	0.09	0.00	0.00	0.000
Pipe P7	36	100	100	0.09	0.01	0.00	0.073
Pipe P8	7	200	110	91.75	2.92	53.80	0.025
Pipe P9	29	200	110	91.75	2.92	53.80	0.025
Pipe P10	62	200	110	-2.10	0.07	0.05	0.043
Pipe P11	7	200	110	93.67	2.98	55.91	0.025
Pipe P12	28	100	100	0.17	0.02	0.02	0.068
Pipe P13	20	200	110	93.50	2.98	55.72	0.025
Pipe P14	4	200	110	-1.50	0.05	0.03	0.046
Pipe P15	30	100	100	0.17	0.02	0.02	0.068
Pipe P16	68	200	110	-1.87	0.06	0.04	0.044
Pipe P17	30	100	100	0.17	0.02	0.02	0.069
Pipe P18	2	200	110	-2.27	0.07	0.05	0.039
Pipe P19	24	200	110	-97.27	3.10	59.95	0.025
Pipe P20	27	100	100	0.17	0.02	0.02	0.069
Pipe P21	1	200	110	-97.44	3.10	60.15	0.025
Pipe P22	29	200	110	-99.71	3.17	62.77	0.024
Pipe P23	6	200	110	-58.01	1.85	23.02	0.027
Pipe P24	27	100	100	0.17	0.02	0.02	0.068
Pipe P25	39	200	110	-58.27	1.85	23.21	0.026
Pipe P26	7	200	110	-41.70	1.33	12.49	0.028
Pipe P27	13	200	110	-118.70	3.78	86.69	0.024
Pipe P28	27	100	100	0.17	0.02	0.02	0.068
Pipe P29	48	200	110	-118.97	3.79	87.05	0.024
Pipe P30	35	200	110	-119.06	3.79	87.16	0.024



Engineers, Planners & Landscape Architects

3400 Woodroffe Avenue - Watermain Analysis

Post-SUC Pressure Zone Reconfiguration

Network Table - Nodes - (Max Day + FF '267L/s')

Node ID	Elevation m	Demand LPS	Head m	Pressure m	Pressure kPa	Pressure psi
Junc CAP1	104.1	0.17	129.91	25.82	253.29	36.74
Junc CAP2	104.05	0.09	129.91	25.86	253.69	36.79
Junc CAP3	104.06	0.17	127.61	23.55	231.03	33.51
Junc CAP4	103.72	0.17	126.48	22.76	223.28	32.38
Junc CAP5	103.74	0.17	126.48	22.74	223.08	32.35
Junc CAP6	104.17	0.17	127.92	23.75	232.99	33.79
Junc CAP7	104.1	0.17	131.01	26.91	263.99	38.29
Junc CAP8	104.17	0.17	129.94	25.77	252.80	36.67
Junc HYD1	103.85	0	129.53	25.68	251.92	36.54
Junc HYD2	103.86	95	126.48	22.62	221.90	32.18
Junc HYD3	103.88	95	126.48	22.6	221.71	32.16
Junc HYD4	103.84	77	129.91	26.07	255.75	37.09
Junc N1	103.11	0.17	134.21	31.1	305.09	44.25
Junc N2	103.64	0.09	135.22	31.58	309.80	44.93
Junc RED1	103.65	0	129.91	26.26	257.61	37.36
Junc T1	103.74	0.09	130.84	27.1	265.85	38.56
Junc T2	103.69	0	129.91	26.22	257.22	37.31
Junc T3	103.7	0.09	129.91	26.21	257.12	37.29
Junc T4	103.83	0.17	128	24.17	237.11	34.39
Junc T5	103.81	0	127.61	23.8	233.48	33.86
Junc T6	103.88	0.22	126.48	22.6	221.71	32.16
Junc T7	103.91	0.22	126.48	22.57	221.41	32.11
Junc T8	103.88	0	127.92	24.04	235.83	34.20
Junc T9	103.87	0.17	128	24.13	236.72	34.33
Junc T10	103.86	0	129.82	25.96	254.67	36.94
Junc T11	103.85	0.09	129.94	26.09	255.94	37.12
Junc T12	103.8	0.09	131.01	27.21	266.93	38.71
Resvr RES1	138.96	-149.83	138.96	0	0.00	0.00
Resvr RES2	138.33	-119.87	138.33	0	0.00	0.00

Network Table - Links - (Max Day + FF '267L/s')

Link ID	Length m	Diameter mm	Roughness	Flow LPS	Velocity m/s	Headloss m/km	Friction Factor
Pipe P1	36	200	110	149.83	4.77	133.43	0.023
Pipe P2	25	200	110	149.65	4.76	133.14	0.023
Pipe P3	17	200	110	91.89	2.93	53.96	0.025
Pipe P4	18	200	110	0.35	0.01	0.00	0.064
Pipe P5	27	100	100	0.17	0.02	0.02	0.068
Pipe P6	7	200	110	0.09	0.00	0.00	0.000
Pipe P7	36	100	100	0.09	0.01	0.00	0.073
Pipe P8	7	200	110	91.54	2.91	53.58	0.025
Pipe P9	29	200	110	91.54	2.91	53.58	0.025
Pipe P10	62	200	110	-2.30	0.07	0.06	0.043
Pipe P11	7	200	110	93.66	2.98	55.90	0.025
Pipe P12	28	100	100	0.17	0.02	0.02	0.069
Pipe P13	20	200	110	93.49	2.98	55.71	0.025
Pipe P14	4	200	110	-1.51	0.05	0.03	0.045
Pipe P15	30	100	100	0.17	0.02	0.02	0.068
Pipe P16	68	200	110	-1.88	0.06	0.04	0.044
Pipe P17	30	100	100	0.17	0.02	0.02	0.069
Pipe P18	2	200	110	-2.28	0.07	0.05	0.039
Pipe P19	24	200	110	-97.28	3.10	59.96	0.025
Pipe P20	27	100	100	0.17	0.02	0.02	0.067
Pipe P21	1	200	110	-97.45	3.10	60.16	0.025
Pipe P22	29	200	110	-99.92	3.18	63.02	0.024
Pipe P23	6	200	110	-57.41	1.83	22.58	0.027
Pipe P24	27	100	100	0.17	0.02	0.02	0.068
Pipe P25	39	200	110	-57.67	1.84	22.77	0.027
Pipe P26	7	200	110	-42.52	1.35	12.95	0.028
Pipe P27	13	200	110	-119.52	3.80	87.79	0.024
Pipe P28	27	100	100	0.17	0.02	0.02	0.068
Pipe P29	48	200	110	-119.78	3.81	88.15	0.024
Pipe P30	35	200	110	-119.87	3.82	88.27	0.024

APPENDIX B

Sanitary Design Sheets

SANITARY SEWER DESIGN SHEET

Novatech Project #: 124147
 Project Name: 3400 Woodroffe Avenue
 Date: 11/4/2025
 Input By: Lucas Wilson
 Reviewed By: Mark Bissett
 Drawing Reference: 124147-GP

Legend: Design Input by User
 As-Built Input by User
 Cumulative Cell
 Calculated Design Cell Output
 Calculated Annual Cell Output
 Calculated Rare Cell Output
 Reference: City of Ottawa - Sewer Design Guidelines (2012 and TBs)
 MOE - Design Guidelines for Sewage Works (2008)

Location				Demand																		Design Capacity									
Street	Area ID	From MH	To MH	Residential Flow										Industrial / Commercial / Institutional (ICI) Flow						Extraneous Flow Area Method		Total Design Flow Q(D) (L/s)	Proposed Sewer Pipe Sizing / Design								
				Singles	Semis / Towns	Apts	Park Area	Population (in 1000's)	Cumulative Population (in 1000's)	Average Pop. Flow Q(q) (L/s)	Design Peaking Factor M	Peak Design Pop. Flow Q(p) (L/s)	Res. Drainage Area (ha.)	Cumulative Res. Drainage Area (ha.)	Commercial / Institutional Area (ha.)	Cumulative Commercial / Institutional Area (ha.)	Average Design Commercial / Institutional Flow (L/s)	Commercial / Institutional Peaking Factor	Cumulative ICI Area (ha.)	Peak Design ICI Flow Q(ici) (L/s)	Cumulative Extraneous Drainage Area (ha.)		Design Extraneous Flow Q(e) (L/s)	Pipe Length (m)	Pipe Size (mm) and Material	Pipe ID Actual (m)	Roughness n	Design Grade So (%)	Capacity Qfull (L/s)	Full Flow Velocity (m/s)	Q(D) / Qfull
3400 Woodroffe Avenue																															
		123	114		17			0.046	0.046	0.15	3.66	0.54	0.260	0.260	0.000	0.000	0.00	1.00	0.000	0.00	0.260	0.09	0.63	60.4	200 PVC	0.203	0.013	0.50	24.2	0.75	2.6%
		114	113		5	6		0.024	0.070	0.23	3.63	0.82	0.220	0.220	0.000	0.000	0.00	1.00	0.000	0.00	0.220	0.07	0.90	32.8	200 PVC	0.203	0.013	0.50	24.2	0.75	3.7%
		120	113		16			0.043	0.043	0.14	3.66	0.51	0.180	0.180	0.000	0.000	0.00	1.00	0.000	0.00	0.180	0.06	0.57	67.3	200 PVC	0.203	0.013	0.65	27.6	0.85	2.1%
		113	112			12		0.022	0.135	0.44	3.56	1.56	0.130	0.530	0.000	0.000	0.00	1.00	0.000	0.00	0.530	0.17	1.73	43.0	200 PVC	0.203	0.013	0.50	24.2	0.75	7.2%
		112	111		3	24		0.051	0.186	0.60	3.53	2.13	0.280	0.810	0.000	0.000	0.00	1.00	0.000	0.00	0.810	0.27	2.40	23.0	200 PVC	0.203	0.013	0.50	24.2	0.75	9.9%
		122	121		6	6		0.027	0.027	0.09	3.69	0.32	0.140	0.140	0.000	0.000	0.00	1.00	0.000	0.00	0.140	0.05	0.37	33.2	200 PVC	0.203	0.013	0.50	24.2	0.75	1.5%
		121	120					0.000	0.027	0.09	3.69	0.32	0.060	0.200	0.000	0.000	0.00	1.00	0.000	0.00	0.200	0.07	0.39	31.0	200 PVC	0.203	0.013	0.50	24.2	0.75	1.6%
		120	119			12		0.022	0.049	0.16	3.65	0.58	0.120	0.320	0.000	0.000	0.00	1.00	0.000	0.00	0.320	0.11	0.68	35.5	200 PVC	0.203	0.013	0.50	24.2	0.75	2.8%
		119	117		1	24		0.046	0.095	0.31	3.60	1.10	0.190	0.510	0.000	0.000	0.00	1.00	0.000	0.00	0.510	0.17	1.27	10.3	200 PVC	0.203	0.013	0.50	24.2	0.75	5.3%
		117	111		4	12		0.032	0.127	0.41	3.57	1.47	0.140	0.650	0.000	0.000	0.00	1.00	0.000	0.00	0.650	0.21	1.68	34.4	200 PVC	0.203	0.013	0.50	24.2	0.75	7.0%
		111	110			12		0.022	0.335	1.09	3.45	3.74	0.086	1.546	0.000	0.000	0.00	1.00	0.000	0.00	1.546	0.51	4.25	35.2	200 PVC	0.203	0.013	0.50	24.2	0.75	17.6%
		110	EX 155					0.000	0.335	1.09	3.45	3.74	0.060	1.606	0.000	0.000	0.00	1.00	0.000	0.00	1.606	0.53	4.27	34.1	200 PVC	0.203	0.013	0.68	28.2	0.87	15.1%
Off-Site																															
Stoneleigh Street		Ex 155	Ex 145					0.019	0.354	1.15	3.44	3.94	0.128	1.734	0.240	0.240	0.08	1.00	0.240	0.08	1.974	0.85	4.67	25.0	200 PVC	0.203	0.013	1.60	43.3	1.33	10.8%
Stoneleigh Street		Ex 145	Ex 146					0.067	0.420	1.36	3.41	4.64	0.670	2.404	0.000	0.240	0.08	1.00	0.240	0.08	2.644	0.87	5.59	96.0	200 PVC	0.203	0.013	1.75	45.3	1.40	12.4%
Shady Grove Street		Ex 146	Ex 148					0.144	0.564	1.83	3.36	6.13	1.450	3.854	0.000	0.240	0.08	1.00	0.240	0.08	4.094	1.35	7.56	72.3	200 PVC	0.203	0.013	0.89	32.3	1.00	23.4%
Marabrooke Street		Ex 148	Ex 149					0.035	0.599	1.94	3.35	6.49	0.430	4.284	0.000	0.240	0.08	1.00	0.240	0.08	4.524	1.49	8.06	46.6	200 PVC	0.203	0.013	1.14	36.5	1.13	22.1%
Marabrooke Street		Ex 149	Ex 150					0.011	0.609	1.97	3.34	6.60	0.250	4.534	0.000	0.240	0.08	1.00	0.240	0.08	4.774	1.58	8.25	11.8	200 PVC	0.203	0.013	1.44	41.1	1.27	20.1%
Marabrooke Street		Ex 150	Ex 151					0.039	0.648	2.10	3.33	6.99	0.370	4.904	0.000	0.240	0.08	1.00	0.240	0.08	5.144	1.70	8.77	68.8	200 PVC	0.203	0.013	1.51	42.0	1.30	20.8%
Whitewater Drive		Ex 141	Ex 151					0.080	0.080	0.26	3.62	0.93	1.460	1.460	0.000	0.000	0.00	1.00	0.000	0.00	1.460	0.48	1.42	71.3	200 PVC	0.203	0.013	1.11	36.0	1.11	3.9%
Whitewater Drive		Ex 151	Ex 152					0.008	0.735	2.38	3.31	7.88	0.140	6.504	0.000	0.000	0.00	1.00	0.000	0.00	6.504	2.15	10.02	56.4	200 PVC	0.203	0.013	0.55	25.4	0.78	39.5%
Totals					0	52	108	0.000	0.735	0.735	2.38	3.31	7.88	6.764	6.764	0.240	0.240	0.08	1.00	0.240	0.08	7.004	2.31	10.27	888.4						

Demand Equation / Parameters

- Q(D), Q(A), Q(R) = $Q(p) + Q(ft) + Q(ici) + Q(e)$
- Q(p) = $(P \times q \times M \times K / 86,400)$
- q = $\frac{280}{\text{L/person/day}}$ (design)
 $\frac{200}{\text{L/person/day}}$ (annual and rare)
- M = Harmon Formula (maximum of 4.0)
- K = $\frac{0.8}{\text{(design)}}$
 $\frac{0.6}{\text{(annual and rare)}}$
- Park flow is considered equivalent to a single unit / ha
Park Demand = $\frac{4}{\text{single unit equivalent / park ha (~ 3,600 L/ha/day)}}$
- Q(ft) = $\frac{0.45}{\text{L/s/unit}}$
- Q(ici) = $\frac{0.33}{\text{L/s/ha}}$ (design)
 $\frac{0.30}{\text{L/s/ha}}$ (annual)
 $\frac{0.55}{\text{L/s/ha}}$ (rare)

Definitions

Q(D) = Peak Design Flow (L/s)
 Q(A) = Peak Annual Flow (L/s)
 Q(R) = Peak Rare Flow (L/s)
 Q(p) = Peak Design Population Flow (L/s)
 Q(q) = Average Population Flow (L/s)

	Singles	Semis / Towns	Apts
P = Residential Population =	3.4	2.7	1.8
q = Average Capita Flow			
M = Harmon Formula			
K = Harmon Correction Factor			
Typ. Service Diameter (mm) =	135		
Typ. Service Length (m) =	15	15	
II Pipe Rate (L/mm dia/m/hr) =	0.007		
Q(ft) = Foundation Flow (L/s)			
Q(ici) = Industrial / Commercial / Institutional Flow (L/s)			
Q(e) = Extraneous Flow (L/s)			

	Industrial / Commercial / Institutional	Industrial	Commercial / Institutional
Design =	35000	28000	L/gross ha/day
Annual / Rare =	10000	17000	L/gross ha/day

ICI Peak *

Design =	1.0	1.5	* ICI Peak = 1.0 Default, 1.5 if ICI in contributing area is >20% (design only)
Annual / Rare =		1.0	

Capacity Equation

$$Q_{full} = 1000(1/n)A_p R^{2/3} S_0^{0.5}$$

Definitions

Q full = Capacity (L/s)
 n = Manning coefficient of roughness (0.013)
 A_p = Pipe flow area (m²)
 R = Hydraulic Radius of wetted area (dia/4 for full pipes)
 S₀ = Pipe slope/gradient



APPENDIX C: Drawings

STM Design Sheets
PCSWMM Modelling Info
SWM Excerpts

**STORM SEWER CALCULATIONS for
Chapman Mills
Woodroffe Avenue**

09/12/2015]2:18 PM

LOCATION					INDIV. 2.78AR	ACCUM. 2.78AR	TIME OF CONC.	RAINFALL INTENSITY I	PEAK FLOW Q (l/s)	PROPOSED SEWER						%FULL
STREET	FROM MH	TO MH	R= 0.5	R= 0.6						PIPE SIZE (mm)	GRADE (%)	LENGTH (m)	CAPACITY (l/s)	FULL FLOW VELOCITY (m/s)	TIME OF FLOW (min)	
Woodroffe Ave.	201	202	2.48		3.45	3.45	26.00	59.35	204.57	457.2	0.69	85.0	247.32	1.51	0.94	
Woodroffe Ave.	202	203	0.25	0.89	1.83	5.28	26.94	57.96	306.01	533.4	0.71	111.9	378.43	1.69	1.10	
Woodroffe Ave.	203	204		0.00	0.00	5.28	28.04	56.44	297.94	533.4	0.74	6.8	386.34	1.73	0.07	
Rear Yard Lead	EX CB	Main		0.18	0.30	0.30	15.00	83.56	25.09	203.2	1.00	18.0	34.25	1.06	0.28	
Woodroffe Ave.	204	205		0.15	0.25	5.83	28.11	56.35	328.49	609.6	0.69	39.0	532.63	1.82	0.36	
Woodroffe Ave.	205	206		0.43	0.72	6.55	28.46	55.87	365.80	685.8	0.61	71.0	685.60	1.86	0.64	
Rear Yard Lead	EX CB	Main		0.51	0.85	0.85	15.00	83.56	71.08	254.0	2.00	18.5	87.82	1.73	0.18	
Woodroffe Ave.	206	207		0.47	0.78	8.18	29.10	55.05	450.37	685.8	0.60	120.0	679.95	1.84	1.09	
Woodroffe Ave.	207	Ex. Stm MH 1			0.00	8.18	30.19	53.70	439.35	685.8	1.35	67.9	1019.93	2.76	0.41	
Woodroffe Ave.	Ex. Stm MH 1	Ex. Stm MH 2			0.00	17.57	30.60	53.21	935.04	762.0	0.89	32.1	1096.78	2.41	0.22	

Run-off Coefficient = 0.6 for all areas, with the following exceptions; Peak Flow = Accumulated 2.78AR x Rainfall Intensity
= 0.20 for Parkland

Rainfall Intensity = $998.071 / (T + 6.053)^{0.814}$ T= time in minutes
(City of Ottawa, 5 year storm)

5.3 Levels of Service

5.3.1. Minor System

- I. **Lateral sewer system to be designed using the Rational Method and the 5-year Intensity Duration Frequency Curve - Nepean DWG IDF-93 (See Appendix E).**
 - I-a Inlet time in typical residential areas = 20 min
 - I-b Average runoff coefficient for residential areas does not exceed $C_{max} = 0.55$ (asphalt = 0.9, grass = 0.2)
 - I-c Calculation of the hydraulic grade line to be conducted only for the surcharged lateral sewers that are connected to the trunk sewer at surcharged sections.
 - I-d Surge calculations to be based on the steady state Darcy-Weisbach formula using maximum water level in the trunk junction as the starting hydraulic grade line elevation.
 - I-e Maximum permitted hydraulic grade line elevation to be 0.30m below the underside of building foundations.
- II. **Density of inlets connected to the minor system to be restricted to a maximum of 3.5 inlets per hectare with the equivalent capacity of Inlet Control Device SCEPTOR type "A" – 20.0 l/s or the equivalent of 70 l/s/ha.**
- III. **Trunk storm sewers to be designed based on the results of hydrological/hydrodynamic modeling using XP-SWMM.**
 - III-a Modeling to be based on the 5 and 100 year Chicago design storm of 12 hour duration and 20 minutes time step, derived from the Nepean IDF-93 curves (see Appendix E).
 - III-b Modeling to be based on the inlet densities and restrictions specified in paragraph II above.
 - III-c Hydraulic grade line modeling to be based on the hydrodynamic fluctuation of the water levels in the Strandherd SWM facility.
 - III-d Maximum permitted hydraulic grade line elevation to be 0.30m below the underside of basement floor slab (top of footing).

5.3.2 Major system

- I **Major flow to be accommodated by a combination of on-site detention and overland flow conveyance with no-ponding**
- II **The storage versus conveyance requirements for areas of average runoff coefficient less than $c = 0.55$ to be determined using the chart enclosed in Appendix F.**
- III **Residential Development:**

Modeling is not required for densities with the average runoff coefficient lower than $C = 0.55$. The maximum on-site detention storage requirement during the 100 year storm is 130 m³/ha assuming no-overflow and that the average runoff coefficient does not exceed 0.55.

 - III-a On-site detention storage may be provided by:
 - low laying park surfaces, and/or,
 - fairly evenly distributed road/rear yard sawtooth design, and/or,
 - combination of both sawtooth design and park storage
 - III-b Maximum hydrostatic depth in roadways sags = 0.25m

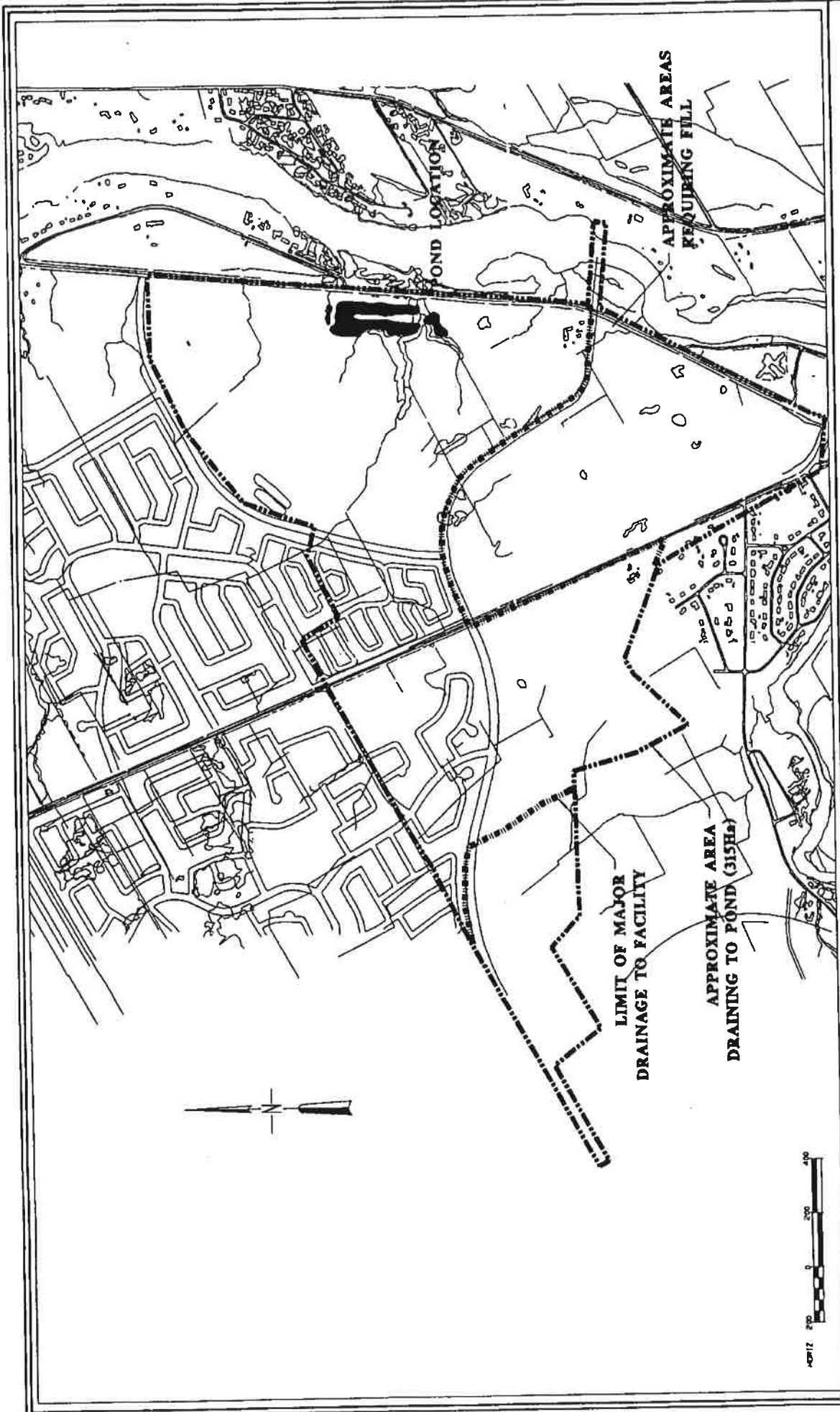

Title:

FACILITY DRAINAGE BOUNDARIES

FIGURE DBB



CITY OF NEPEAN
PUBLIC WORKS DEPARTMENT

CG&S
CH2M Gobe & Storie Limited

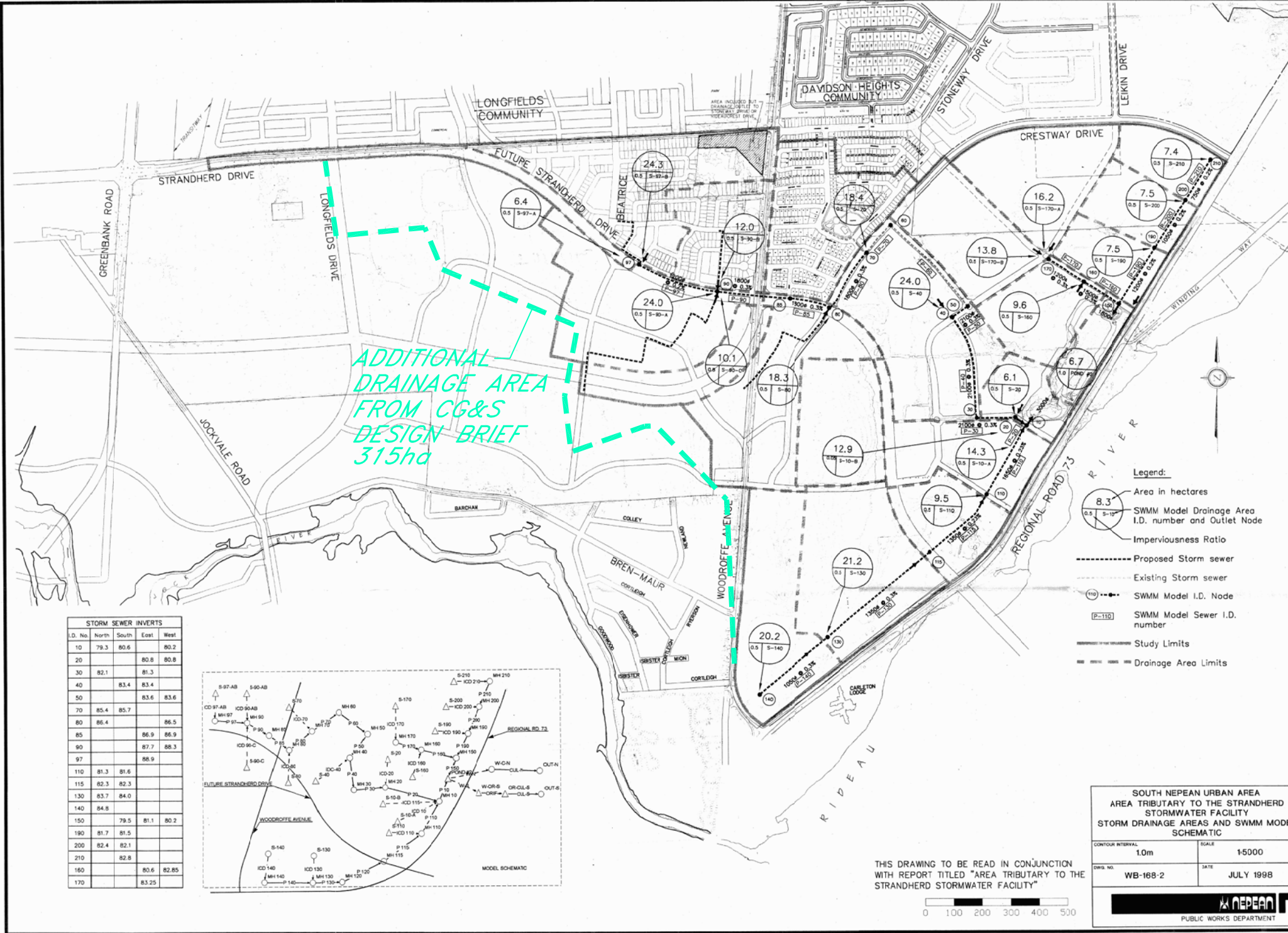

ADDITIONAL
DRAINAGE AREA
FROM CG&S
DESIGN BRIEF
315ha

- Legend:**
- 8.3 Area in hectares
 - 0.5 S-10 SWMM Model Drainage Area I.D. number and Outlet Node
 - Imperviousness Ratio
 - Proposed Storm sewer
 - Existing Storm sewer
 - 110 SWMM Model I.D. Node
 - P-110 SWMM Model Sewer I.D. number
 - Study Limits
 - Drainage Area Limits

STORM SEWER INVERTS				
I.D. No.	North	South	East	West
10	79.3	80.6		80.2
20			80.8	80.8
30	82.1			81.3
40		83.4		
50			83.6	83.6
60	85.4	85.7		
70				86.5
80	86.4			
85			86.9	86.9
90			87.7	88.3
97				88.9
110	81.3	81.6		
115	82.3	82.3		
130	83.7	84.0		
140	84.8			
150		79.5	81.1	80.2
190	81.7	81.5		
200	82.4	82.1		
210		82.8		
160			80.6	82.85
170			83.25	

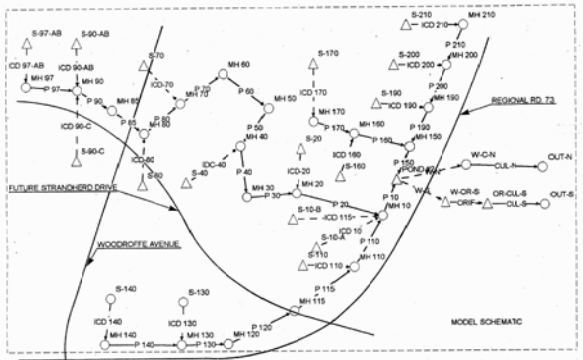

SOUTH NEPEAN URBAN AREA
AREA TRIBUTARY TO THE STRANDHERD
STORMWATER FACILITY
STORM DRAINAGE AREAS AND SWMM MODEL
SCHEMATIC

CONTOUR INTERVAL	1.0m	SCALE	1:5000
DRAW. NO.	WB-168-2	DATE	JULY 1998

THIS DRAWING TO BE READ IN CONJUNCTION
WITH REPORT TITLED "AREA TRIBUTARY TO THE
STRANDHERD STORMWATER FACILITY"

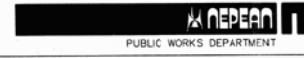



David M^cManus
Engineering Ltd.

JUNE 2/04
SNC

June 2, 2004

Cecil D. Naraine Associates Limited
Consulting Engineers
1097 Lena Avenue
Manotick, Ontario
K4M 1E7

Attn: Mr. D. Cecil Naraine, P.Eng.

Dear Sir:

Re: Borrello's Property, Woodroffe Avenue - Our File 2420

We have received your letter of April 13, 2004 requesting that capacity for the Borrello property be provided in the future storm sewer system that will be constructed on Woodroffe Avenue. We have discussed this request with Minto Developments Inc. and they have agreed to provide capacity for Borrello, subject to Borrello cost sharing on applicable works. Your client must negotiate with Minto directly on cost sharing.

As you know, the storm sewer system in this area outlets to the Strandherd SWM facility on Prince of Wales Drive. CH2M Gore & Storrie Limited prepared the *South Nepean Strandherd Stormwater Facility Design Brief (February 1998)* for the stormwater management facility on Prince of Wales Drive. This report indicates that the Strandherd SWM facility has capacity to accommodate minor system flows from 315 ha of developed area. The drainage area from Minto's lands and the Borrello property is a total of 300 ha. Therefore there is capacity in the Strandherd SWM facility. We have attached information from the CH2M Gore & Storrie Design Brief for your information.

Please call if you have any questions or concerns.

Regards,

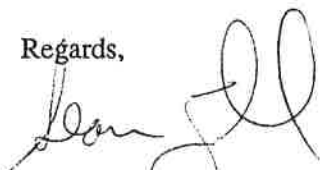

Sean Czaharynski, P.Eng.
Senior Project Manager

cc Mr. Marcel Denomme, Minto Developments Inc.

400 - 30 Camelot Drive, Nepean, Ontario K2G 5X8
Tel: 613-225-1929 Fax: 613-225-7330 E-mail: mcmanus@dmel.on.ca

Municipal and Land Development Consultants

1.0 TREATMENT FACILITY OVERVIEW

1.1 General

The Strandherd Stormwater Facility will receive stormwater flow from developments in South Nepean. The purpose of the proposed works is to provide treatment for influent stormwater prior to discharge into the Rideau River in order to achieve water quality targets for the Rideau River and to meet provincial water quality standards. Figure DB 'A' shows the location of the facility with respect to other areas in South Nepean. The following sections outline the general shape and configuration, operating water levels and hydraulic operation of the facility.

Inflow to the facility will be routed first into either the north or south forebay prior to discharge into the main cell. A constant outflow rate will be maintained from the facility during discharge events, with a typical water level fluctuation of approximately 1.1 m during these events. This constant outflow is an operational requirement for the potential future UV facility, but in the interim (prior to installation of UV) the flow control will help enhance the water quality of facility effluent by increasing facility mean retention times.

Storm events up to 5-year return period which exceed the treatment level in the facility will be discharged via the main southern outlet from the facility through the existing culvert on Strandherd Creek. This outlet will be designed to pass 2.3 m³/s at 5-year pond water levels. Flows from storms beyond this 5-year return period in excess of the capacity of the main outlet will be bypassed via the high level overflow spillway for the facility located near the south entrance to Winding Way. This outlet will ensure that water levels in the facility do not exceed an elevation of 82.5 m under storms equal to the 100-year design storm event. It is expected that the discharge from this outlet will be approximately 7 m³/s in this event.

Flow measurement and water quality monitoring equipment will be required at each of the inlets and at the main (south) facility outlet. This equipment will be used to monitor the performance of the facility with respect to water quality parameters of concern.

1.2 Facility Sizing

Sizing of the stormwater facility was performed as part of the pre-design process. This sizing was based on several criteria; the level of protection required based on fisheries habitat in receiving waters, the size of the contributing area, and the imperviousness of this contributing area all affect the facility size required. The portion of the major flows from the development to be directed through the facility as well as the outlet configuration and operation were also considered in the design.

1.2.1 Drainage Area

The facility is designed to accommodate minor system flows from 315 ha of developed area with an average runoff coefficient of 0.47. The facility provides enough storage to meet MOEE (1994) Level 1 protection sizing guidelines for a 55% impervious area, which is based on a reduction in the incoming suspended solids load by an average of 80%.

EXISTING CONDITIONS - AREAS DIRECTED TO WOODROFFE AVE

Time-of-Concentration (Uplands Method)

Flow Classification (Land Use)	Length (m)	Elevation		Slope (%)	Velocity ¹ (m/s)	Time-of- Concentration (min)
		U/S (m)	D/S (m)			
Overland Flow (Pasture)	70	104.5	103.0	2.1%	0.30	3.9
Paved Areas (Sheet Flow)	10	102.1	101.8	3.0%	1.00	0.2
TOTAL	80	104.5	101.8	3.4%	0.39	10.0

¹ Refer to Uplands Velocity Chart.

*Min 10-minutes.

Existing Catchment Parameters

Catchment ID	Areas (ha)			Runoff Coefficient		%Imperv.
	Total	Hard Surfaces (C=0.90)	Soft Surfaces (C=0.20)	C _{avg}	C _{100yr} ¹	
TOTAL (EX-02, EX-03)	1.221	0.157	1.064	0.29	0.35	12.9%

¹ Runoff coefficient increases by 25%, up to a maximum value of 1.00, for the 100-year event.

Pre-Development Peak Flows

Catchment ID	Rainfall Intensity (mm/hr) ¹			Peak Flows (L/s)		
	2-year	5-year	100-year	2-year	5-year	100-year
Site Boundary (existing conditions)	76.81	104.19	178.56	75.6	102.6	210.0

¹ Tc is based on Uplands Method.

Notes:

Rainfall Intensity from City of Ottawa Sewer Design Guidelines

- 100 year Intensity = $1735.688 / (Tc + 6.014)^{0.820}$
- 5 year Intensity = $998.071 / (Tc + 6.053)^{0.814}$
- 2 year Intensity = $732.951 / (Tc + 6.199)^{0.810}$

$$Q(\text{peak flow}) = 2.78 \times C \times I \times A$$

- C is the runoff coefficient
- I is the rainfall intensity
- A is the total drainage area

EXISTING CONDITIONS - AREAS TO WESTERN PROPERTY LINE (NEWLAND DR)

Time-of-Concentration (Uplands Method)

Flow Classification (Land Use)	Length (m)	Elevation		Slope (%)	Velocity ¹ (m/s)	Time-of- Concentration (min)
		U/S (m)	D/S (m)			
Overland Flow (Pasture)	80	104.5	101.0	4.4%	0.50	2.7
TOTAL	80	104.5	101.0	4.4%	0.50	10.0

¹ Refer to Uplands Velocity Chart.

*Min 10-minutes.

Existing Catchment Parameters

Catchment ID	Areas (ha)			Runoff Coefficient		%Imperv.
	Total	Hard Surfaces (C=0.90)	Soft Surfaces (C=0.20)	C _{avg}	C _{100yr} ¹	
TOTAL (EX-01)	1.286	0.055	1.231	0.23	0.28	4.3%

¹ Runoff coefficient increases by 25%, up to a maximum value of 1.00, for the 100-year event.

Pre-Development Peak Flows

Catchment ID	Rainfall Intensity (mm/hr) ¹			Peak Flows (L/s)		
	2-year	5-year	100-year	2-year	5-year	100-year
Site Boundary (existing conditions)	76.81	104.19	178.56	63.2	85.7	180.1

¹ Tc is based on Uplands Method.

Notes:

Rainfall Intensity from City of Ottawa Sewer Design Guidelines

- 100 year Intensity = $1735.688 / (Tc + 6.014)^{0.820}$
- 5 year Intensity = $998.071 / (Tc + 6.053)^{0.814}$
- 2 year Intensity = $732.951 / (Tc + 6.199)^{0.810}$

$$Q(\text{peak flow}) = 2.78 \times C \times I \times A$$

- C is the runoff coefficient
- I is the rainfall intensity
- A is the total drainage area

Calculation of Peak Flows

$$Q_p = 2.78 \times C \times I \times A$$

**Rational Method Equation*

Where:

Q_p = Peak Flow (L/s)

C = Runoff Coefficient (increases by 25% for a 100-year event; max 1.0)

I = Rainfall Intensity (mm)

**Based on City of Ottawa IDF data using a 10-minute time-of-concentration (T_c)*

A = Drainage Area (ha)

Sample Calculation for 100-year Storm Event:

Drainage Area = 2.280 ha

Runoff Coefficient = 0.36 (100-year)

Rainfall Intensity = 170.13 mm/hr (based on 11-minute T_c ; City of Ottawa IDF data)

$$Q_p = 2.78 \times 0.36 \times 170.13 \text{ mm/hr} \times 2.280 \text{ ha}$$

$$Q_p = 385.1 \text{ L/s}$$

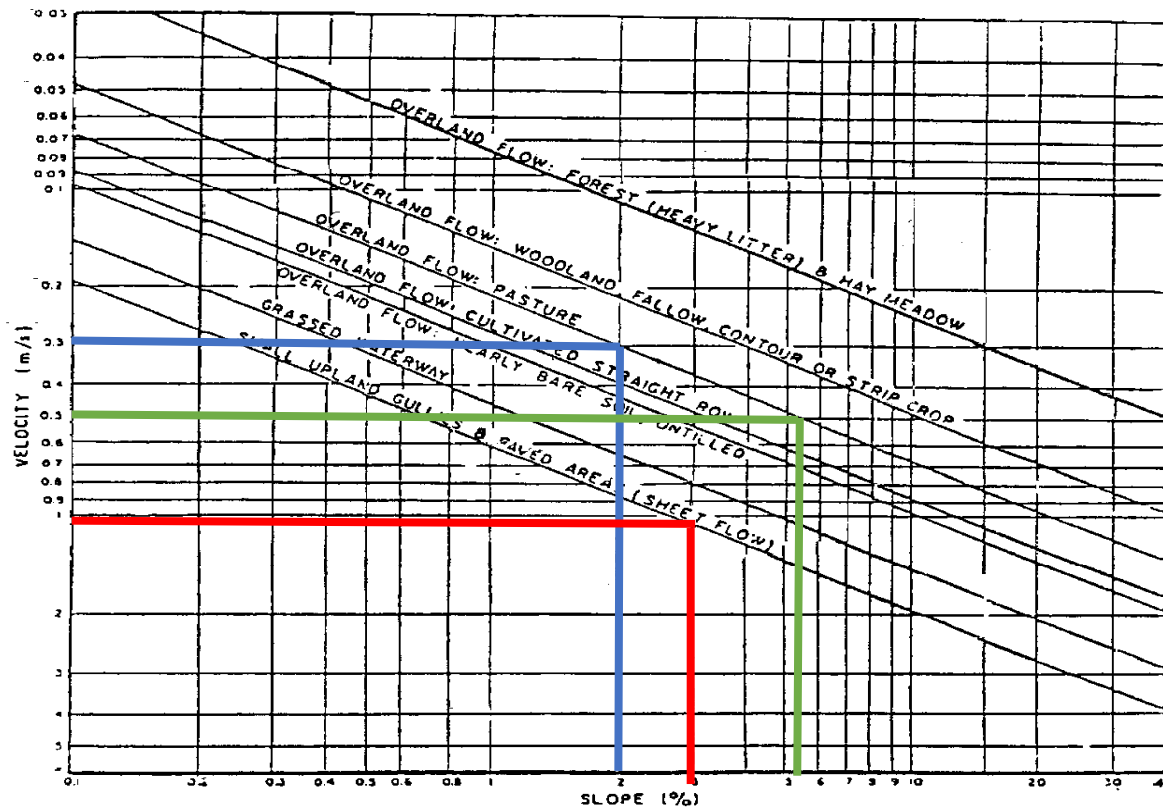

Figure A.5.2: Upland Method for Estimating Time of Concentration
(SCS National Engineering Handbook, 1971)

STORM SEWER DESIGN SHEET
(Phoenix Homes)
FLOW RATES BASED ON RATIONAL METHOD



LOCATION				AREA (ha)			FLOW							TOTAL FLOW	SEWER DATA									
Street	Catchment ID	From Manhole	To Manhole	Area (ha)	C	AC (ha)	Indiv 2.78 AC	Accum 2.78 AC	Time of Concentration	Rainfall Intensity 2 Year (mm/hr)	Rainfall Intensity 5 Year (mm/hr)	Rainfall Intensity 10 Year (mm/hr)	Peak Flow (L/s)	Total Peak Flow, Q (L/s)	Dia. (m) Actual	Dia. (mm)	Type	Slope (%)	Length (m)	Capacity (L/s)	Velocity (m/s)	Flow Time (min)	Ratio Q/Q full	
	A-01, A-04	CBMH3	214	0.243	0.55	0.13	0.372	0.372	10.00	76.81			10.00	28.5	28.5	0.305	300	PVC	0.30	19.0	55.2	0.76	0.42	52%
	A-05 to A-08, A-13, A-24	214	213	0.442	0.72	0.32	0.885	1.256	10.42	75.23			10.42	94.5	94.5	0.381	375	PVC	0.40	79.0	115.6	1.01	1.30	82%
	A-14, A-15	213	212	0.203	0.77	0.16	0.435	1.691	11.72	70.79			11.72	119.7	119.7	0.457	450	Conc	0.30	26.8	162.8	0.99	0.45	74%
	A-19	CBMH4	217	0.090	0.77	0.07	0.193	0.193	10.00	76.81			10.00	14.8	14.8	0.305	300	PVC	0.35	12.5	59.6	0.82	0.25	25%
	A-02	217	216	0.118	0.47	0.06	0.154	0.347	10.25	75.84			10.25	26.3	26.3	0.305	300	PVC	0.35	11.0	59.6	0.82	0.22	44%
	A-03, A-09, A-10, A-20	216	215	0.340	0.77	0.26	0.728	1.075	10.48	75.01			10.48	80.6	80.6	0.381	375	PVC	0.30	69.3	100.1	0.88	1.32	81%
	A-11, A-12, A-25	215	212	0.334	0.76	0.25	0.706	1.780	11.79	70.54			11.79	125.6	125.6	0.457	450	Conc	0.25	43.9	148.6	0.91	0.81	85%
		212	211			0.00	0.000	3.471	12.60	68.07			12.60	236.3	236.3	0.457	450	Conc	1.00	34.7	297.2	1.81	0.32	79%
	A-16, A-26 to A-35	211	201	0.237	0.64	0.15	0.422	3.893	12.92	67.15			12.92	261.4	261.4	0.457	450	Conc	0.70	15.6	248.7	1.51	0.17	105%
Woodroffe Ave	A-17, EX-04	201	202	0.188	0.56	0.11	0.293	0.293	13.09	66.67	90.27		13.09	285.9	285.9	0.457	450	Conc	0.75	83.2	257.4	1.57	0.88	111%
						0.00	0.000	0.000	12.92				12.92											

Q = 2.78 AIC, where
 Q = Peak Flow in Litres per Second (L/s)
 A = Area in hectares (ha)
 I = Rainfall Intensity (mm/hr), 5 year storm
 C = Runoff Coefficient

Consultant:	Novatech
Date:	April 14, 2026
Design By:	Lucas Wilson
Client:	
Phoenix Homes	Dwg. Reference: 124147-STM
	Checked By: MAB

Legend:
 * Indicates 100 Year intensity for storm sewers
 10.00 Storm sewers designed to the 2 year event (without ponding) for local roads
 10.00 Storm sewers designed to the 5 year event (without ponding) for collector roads
 10.00 Storm sewers designed to the 10 year event (without ponding) for arterial roads



WOODROFFE AVE SOUTH - STORM SEWER DESIGN SHEET
(Phoenix Homes)
 FLOW RATES BASED ON RATIONAL METHOD



LOCATION				AREA (ha)			FLOW							TOTAL FLOW	SEWER DATA									
Street	Catchment ID	From Manhole	To Manhole	Area (ha)	C	AC (ha)	Indiv 2.78 AC	Accum 2.78 AC	Time of Concentration	Rainfall Intensity 2 Year (mm/hr)	Rainfall Intensity 5 Year (mm/hr)	Rainfall Intensity 10 Year (mm/hr)	Peak Flow (L/s)	Total Peak Flow, Q (L/s)	Dia. (m) Actual	Dia. (mm)	Type	Slope (%)	Length (m)	Capacity (L/s)	Velocity (m/s)	Flow Time (min)	Ratio Q/Q full	
Woodroffe Ave	A-18, EX-02, EX-03	208	209	0.290	0.59	0.17	0.000	0.000	10.00						49.6	0.254	250	PVC	3.19	74.0	110.7	2.18	0.56	45%
						0.00	0.000	0.000	10.00															
						0.00	0.000	0.000	10.56															
Woodroffe Ave	EX-01	209	XSTM3	0.137	0.60	0.08	0.229	0.704	10.56						71.3	0.254	250	PVC	3.04	73.3	108.1	2.13	0.57	66%
						0.00	0.000	0.000	10.56															

Q = 2.78 AIC, where Q = Peak Flow in Litres per Second (L/s) A = Area in hectares (ha) I = Rainfall Intensity (mm/hr), 5 year storm C = Runoff Coefficient	Consultant:	Novatech
	Date:	April 14, 2026
	Design By:	Lucas Wilson
	Client:	
	Phoenix Homes	
	Dwg. Reference:	Checked By:
	124147-STM3	MAB

Legend:
 * Indicates 100 Year intensity for storm sewers
 10.00 Storm sewers designed to the 2 year event (without ponding) for local roads
 10.00 Storm sewers designed to the 5 year event (without ponding) for collector roads
 10.00 Storm sewers designed to the 10 year event (without ponding) for arterial roads



3400 Woodroffe Avenue (124147)
PCSWMM Storage Curves

STM ID	CB ID	Provided Storage	
		Underground	Surface
CB01	A-12	19.3	45.2
Depth (m)	Equivalent Area (m ²)	Incremental Volume (m ³)	Total Volume (m ³)
0.00	0.36	0.0	0.0
1.85	0.36	0.0	0.0
2.17	282.10	45.2	45.2
2.171	0.00	0.0	45.2
2.85	0.00	0.0	45.2

5x Stormtech STC-800 Storage Chambers (19.3 m3)

0.32m Static Ponding Depth (45.2 m3)

STM ID	CB ID	Provided Storage	
		Underground	Surface
CB02	A-11	17.5	50.4
Depth (m)	Equivalent Area (m ²)	Incremental Volume (m ³)	Total Volume (m ³)
0.00	0.36	0.0	0.0
2.04	0.36	0.0	0.0
2.34	335.60	50.4	50.4
2.341	0.00	0.0	50.4
3.04	0.00	0.0	50.4

5x Stormtech STC-800 Storage Chambers (17.5 m3)

0.30m Static Ponding Depth (50.4 m3)

STM ID	CB ID	Provided Storage	
		Underground	Surface
CB03	A-03	8.7	52.9
Depth (m)	Equivalent Area (m ²)	Incremental Volume (m ³)	Total Volume (m ³)
0.00	0.36	0.0	0.0
2.74	0.36	0.0	0.0
3.04	352.30	52.9	52.9
3.041	0.00	0.0	52.9
3.74	0.00	0.0	52.9

2x Stormtech STC-800 Storage Chambers (8.7 m3)

0.30m Static Ponding Depth (52.9 m3)

STM ID	CB ID	Provided Storage	
		Underground	Surface
CB04	A-07	8.7	46.1
Depth (m)	Equivalent Area (m ²)	Incremental Volume (m ³)	Total Volume (m ³)
0.00	0.36	0.0	0.0
1.85	0.36	0.0	0.0
2.18	279.00	46.1	46.1
2.181	0.00	0.0	46.1
2.85	0.00	0.0	46.1

2x Stormtech STC-800 Storage Chambers (8.7 m3)
 0.33m Static Ponding Depth (46.1 m3)

STM ID	CB ID	Provided Storage	
		Underground	Surface
CB05	A-15	12.5	46.3
Depth (m)	Equivalent Area (m ²)	Incremental Volume (m ³)	Total Volume (m ³)
0.00	0.36	0.0	0.0
1.95	0.36	0.0	0.0
2.25	308.30	46.3	46.3
2.251	0.00	0.0	46.3
2.95	0.00	0.0	46.3

3x Stormtech STC-800 Storage Chambers (12.5 m3)
 0.33m Static Ponding Depth (46.3 m3)

STM ID	CB ID	Provided Storage	
		Underground	Surface
CB06	A-14	8.7	38.1
Depth (m)	Equivalent Area (m ²)	Incremental Volume (m ³)	Total Volume (m ³)
0.00	0.36	0.0	0.0
1.85	0.36	0.0	0.0
2.15	253.60	38.1	38.1
2.151	0.00	0.1	38.2
2.85	0.00	0.0	38.2

2x Stormtech STC-800 Storage Chambers (8.7 m3)
 0.30m Static Ponding Depth (38.1 m3)

3400 Woodroffe Avenue (124147)
PCSWMM Storage Curves



STM ID	CB ID	Provided Storage	
		Underground	Surface
CBMH01	A-08	3.3	32.9
Depth (m)	Equivalent Area (m ²)	Incremental Volume (m ³)	Total Volume (m ³)
0.00	1.17	0.0	0.0
2.85	1.17	3.3	3.3
3.15	218.30	32.9	36.2
3.151	0.00	0.1	36.3
3.85	0.00	0.0	36.3

1200mm diameter CBMH (3.3 m3)
0.30m Static Ponding Depth (32.9 m3)

STM ID	CB ID	Provided Storage	
		Underground	Surface
CBMH02	A-05, A-06	5.5	45.0
Depth (m)	Equivalent Area (m ²)	Incremental Volume (m ³)	Total Volume (m ³)
0.00	1.82	0.0	0.0
3.00	1.82	5.5	5.5
3.30	298.30	45.0	50.5
3.301	0.00	0.0	50.5
4.00	0.00	0.0	50.5

1500mm diameter CBMH (5.5 m3)
0.30m Static Ponding Depth (45.0 m3)

STM ID	CB ID	Provided Storage	
		Underground	Surface
CBMH03	A-04	6.3	13.7
Depth (m)	Equivalent Area (m ²)	Incremental Volume (m ³)	Total Volume (m ³)
0.00	1.82	0.0	0.0
3.46	1.82	6.3	6.3
3.66	135.60	13.7	20.0
3.661	0.00	0.0	20.0
4.46	0.00	0.0	20.0

1500mm diameter CBMH (6.3 m3)
0.20m Static Ponding Depth (13.7 m3)

STM ID	CB ID	Provided Storage	
		Underground	Surface
CBMH04	A-19	6.4	14.3
Depth (m)	Equivalent Area (m ²)	Incremental Volume (m ³)	Total Volume (m ³)
0.00	1.82	0.0	0.0
3.50	1.82	6.4	6.4
3.70	141.60	14.3	20.7
3.701	0.00	0.0	20.7
4.50	0.00	0.0	20.7

1500mm diameter CBMH (6.4 m³)
 0.20m Static Ponding Depth (14.3 m³)

STM ID	CB ID	Provided Storage	
		Underground	Surface
CBMH05	A-13	7.5	21.0
Depth (m)	Equivalent Area (m ²)	Incremental Volume (m ³)	Total Volume (m ³)
0.00	2.63	0.0	0.0
2.85	2.63	7.5	7.5
3.10	165.20	21.0	28.5
3.101	0.00	0.0	28.5
3.85	0.00	0.0	28.5

1800mm diameter CBMH (7.5 m³)
 0.25m Static Ponding Depth (21.0 m³)

STM ID	CB ID	Provided Storage	
		Underground	Surface
CBMH06	A-09	8.2	15.9
Depth (m)	Equivalent Area (m ²)	Incremental Volume (m ³)	Total Volume (m ³)
0.00	2.63	0.0	0.0
3.10	2.63	8.2	8.2
3.36	119.64	15.9	24.1
3.361	0.00	0.0	24.1
4.10	0.00	0.0	24.1

1800mm diameter CBMH (8.2 m³)
 0.26m Static Ponding Depth (15.9 m³)

3400 Woodroffe Avenue (124147)
PCSWMM Storage Curves



STM ID	CB ID	Provided Storage	
		Underground	Surface
CBMH07	A-20	2.9	27.4
Depth (m)	Equivalent Area (m ²)	Incremental Volume (m ³)	Total Volume (m ³)
0.00	1.17	0.0	0.0
2.50	1.17	2.9	2.9
2.80	181.60	27.4	30.3
2.801	0.00	0.0	30.3
3.50	0.00	0.0	30.3

1200mm diameter CBMH (2.9 m3)
 0.30m Static Ponding Depth (27.4 m3)

STM ID	CB ID	Provided Storage	
		Underground	Surface
CBMH08	A-10	3.2	27.9
Depth (m)	Equivalent Area (m ²)	Incremental Volume (m ³)	Total Volume (m ³)
0.00	1.17	0.0	0.0
2.75	1.17	3.2	3.2
3.05	185.00	27.9	31.1
3.051	0.00	0.0	31.1
3.75	0.00	0.0	31.1

1200mm diameter CBMH (3.2 m3)
 0.30m Static Ponding Depth (27.9 m3)

3400 Woodroffe (124147)
PCSWMM Model Results (Ponding)



CB ID	Invert Elev. (m)	Rim Elev. (m)	Spill Elev. (m)	Ponding Depth (m)	HGL Elev. (m) ¹				Ponding Depth (m)				Spill Depth (m)			
					2-yr	5-yr	100-yr	100-yr (+20%)	2-yr	5-yr	100-yr	100-yr (+20%)	2-yr	5-yr	100-yr	100-yr (+20%)
CB01	101.66	103.51	103.83	0.32	102.98	103.60	103.79	103.84	0.00	0.09	0.28	0.33	0.00	0.00	0.00	0.01
CB02	101.52	103.56	103.86	0.30	102.90	103.60	103.80	103.86	0.00	0.04	0.24	0.30	0.00	0.00	0.00	0.00
CB03	100.89	103.63	103.93	0.30	102.99	103.69	103.83	103.87	0.00	0.06	0.20	0.24	0.00	0.00	0.00	0.00
CB04	101.70	103.55	103.88	0.33	102.73	103.46	103.73	103.87	0.00	0.00	0.18	0.32	0.00	0.00	0.00	0.00
CB05	101.60	103.55	103.85	0.30	102.85	103.60	103.76	103.81	0.00	0.05	0.21	0.26	0.00	0.00	0.00	0.00
CB06	101.67	103.52	103.82	0.30	102.76	103.52	103.69	103.77	0.00	0.00	0.17	0.25	0.00	0.00	0.00	0.00
CBMH01	100.70	103.55	103.85	0.30	103.06	103.60	103.70	103.74	0.00	0.05	0.15	0.19	0.00	0.00	0.00	0.00
CBMH02	100.63	103.63	103.93	0.30	103.59	103.76	103.92	103.94	0.00	0.13	0.29	0.31	0.00	0.00	0.00	0.01
CBMH03	100.27	103.73	103.93	0.20	103.11	103.81	103.94	103.95	0.00	0.08	0.21	0.22	0.00	0.00	0.01	0.02
CBMH04	100.24	103.74	103.94	0.20	103.26	103.82	103.95	103.96	0.00	0.08	0.21	0.22	0.00	0.00	0.01	0.02
CBMH05	100.80	103.65	103.90	0.25	103.28	103.74	103.87	103.91	0.00	0.09	0.22	0.26	0.00	0.00	0.00	0.01
CBMH06	100.55	103.65	103.91	0.26	103.01	103.73	103.91	103.93	0.00	0.08	0.26	0.28	0.00	0.00	0.00	0.02
CBMH07	101.10	103.60	103.90	0.30	103.15	103.65	103.77	103.86	0.00	0.05	0.17	0.26	0.00	0.00	0.00	0.00
CBMH08	100.82	103.57	103.87	0.30	103.57	103.65	103.76	103.85	0.00	0.08	0.19	0.28	0.00	0.00	0.00	0.00
CBMH09	100.43	103.65	103.73	0.08	101.94	102.20	103.22	103.60	0.00	0.00	0.00	0.00	0.00	0.00	0.00	0.00
CBMH10	102.00	103.50	103.58	0.08	102.04	102.20	103.23	103.61	0.00	0.00	0.00	0.11	0.00	0.00	0.00	0.03
CBMH11	100.44	103.95	103.99	0.04	102.36	102.63	103.60	103.88	0.00	0.00	0.00	0.00	0.00	0.00	0.00	0.00
CBMH12	102.28	103.78	103.83	0.05	102.36	102.63	103.60	103.88	0.00	0.00	0.00	0.10	0.00	0.00	0.00	0.05
LCB01	102.86	103.86	103.94	0.08	103.59	103.76	103.92	103.95	0.00	0.00	0.06	0.09	0.00	0.00	0.00	0.01
LCB02	102.98	103.98	104.05	0.07	102.98	103.61	103.80	103.86	0.00	0.00	0.00	0.00	0.00	0.00	0.00	0.00
RY01	100.61	101.52	101.79	0.27	100.66	100.79	101.73	101.81	0.00	0.00	0.21	0.29	0.00	0.00	0.00	0.02
RY02	100.37	101.52	101.77	0.25	100.66	100.79	101.73	101.81	0.00	0.00	0.21	0.29	0.00	0.00	0.00	0.04
RY03	100.42	101.44	101.75	0.31	100.71	100.85	101.73	101.77	0.00	0.00	0.29	0.33	0.00	0.00	0.00	0.02
RY04	100.69	101.50	101.72	0.22	100.71	100.85	101.73	101.77	0.00	0.00	0.23	0.27	0.00	0.00	0.01	0.05
RY05	102.40	103.86	103.95	0.09	103.59	103.76	103.92	103.95	0.00	0.00	0.06	0.09	0.00	0.00	0.00	0.00
RY06	102.38	103.72	103.96	0.24	102.90	103.61	103.80	103.86	0.00	0.00	0.08	0.14	0.00	0.00	0.00	0.00
RY07	102.90	103.82	103.95	0.13	103.59	103.76	103.92	103.95	0.00	0.00	0.10	0.13	0.00	0.00	0.00	0.00
RY08	102.39	103.79	103.94	0.15	102.47	102.70	103.82	103.87	0.00	0.00	0.03	0.08	0.00	0.00	0.00	0.00
RY09	102.55	103.95	104.00	0.05	102.59	102.60	103.22	103.61	0.00	0.00	0.00	0.00	0.00	0.00	0.00	0.00
RY10	102.52	103.92	103.97	0.05	102.56	102.57	103.22	103.61	0.00	0.00	0.00	0.00	0.00	0.00	0.00	0.00
RY11	102.54	103.94	103.99	0.05	102.58	102.63	103.60	103.88	0.00	0.00	0.00	0.00	0.00	0.00	0.00	0.00
RY12	102.56	103.96	104.01	0.05	102.60	102.63	103.60	103.88	0.00	0.00	0.00	0.00	0.00	0.00	0.00	0.00
RY13	102.52	103.92	103.97	0.05	102.56	102.63	103.60	103.88	0.00	0.00	0.00	0.00	0.00	0.00	0.00	0.00
RY14	102.52	103.92	103.97	0.05	102.56	102.63	103.60	103.88	0.00	0.00	0.00	0.00	0.00	0.00	0.00	0.00

¹ 3-hour Chicago Storm.

3400 Woodroffe (124147)
PCSWMM Model Results (HGL)

MH ID	Obvert Elevation (m)	T/G Elevation (m)	HGL Elevation ¹ (m)	Surcharge (m)	Clearance from T/G (m)	HGL in Stress Test ¹ (m)	USF (m)	Clearance from HGL ² (m)
211	99.72	102.29	99.62	0	2.67	99.64	102.39	2.67
212	100.13	103.78	99.83	0	3.95	99.83	103.76	3.63
213	100.21	103.78	100.03	0	3.75	100.03	102.42	2.21
214	100.52	103.90	100.30	0	3.60	100.30	101.94	1.42
215	100.24	103.90	100.01	0	3.89	100.01	102.43	2.19
216	100.43	103.85	100.20	0	3.65	100.20	101.93	1.50
217	100.46	103.89	100.24	0	3.65	100.25	101.92	1.46
CB02	101.82	103.56	101.57	0	1.99	101.57	102.43	0.61
CB03	101.19	103.60	100.95	0	2.65	100.95	101.93	0.74
CB05	101.90	103.55	101.65	0	1.90	101.65	102.42	0.52
CBMH02	100.93	103.63	100.69	0	2.94	100.69	101.94	1.01
CBMH03	100.57	103.73	100.38	0	3.35	100.38	101.92	1.35
CBMH04	100.54	103.74	100.32	0	3.42	100.32	101.92	1.38

¹ 3-hour Chicago Storm.

² Clearance from the 100-year HGL or pipe obvert (whichever is greater).

3400 Woodroffe Avenue (124147)
PCSWMM Model Output
100yr 3-hour Chicago Storm



EPA STORM WATER MANAGEMENT MODEL - VERSION 5.2 (Build 5.2.4)

 Element Count

 Number of rain gages 1
 Number of subcatchments ... 50
 Number of nodes 121
 Number of links 152
 Number of pollutants 0
 Number of land uses 0

 Raingage Summary

Name	Data Source	Data Type	Recording Interval
RG-1	C3hr-100yr	INTENSITY	10 min.

 Subcatchment Summary

Name	Area	Width	%Imperv	%Slope	Rain Gage	Outlet
A-01	0.15	91.87	31.00	2.0000	RG-1	RY03
A-02	0.12	73.75	38.90	2.0000	RG-1	RY02
A-03	0.12	46.00	83.30	2.5000	RG-1	CB03
A-04	0.10	48.00	79.60	2.0000	RG-1	CBMH03
A-05	0.10	47.50	80.30	1.0000	RG-1	CBMH02
A-06	0.08	52.67	62.70	1.5000	RG-1	RY05
A-07	0.09	46.00	77.10	2.0000	RG-1	CB04
A-08	0.07	32.50	80.30	2.0000	RG-1	CBMH01
A-09	0.09	56.25	84.00	2.0000	RG-1	CBMH06
A-10	0.07	37.00	79.10	2.0000	RG-1	CBMH08
A-11	0.12	40.00	80.70	2.0000	RG-1	CB02
A-12	0.16	53.33	82.40	2.0000	RG-1	CB01
A-13	0.09	55.00	86.40	2.0000	RG-1	CBMH05
A-14	0.08	28.00	82.10	3.0000	RG-1	CB06
A-15	0.12	39.67	79.80	2.0000	RG-1	CB05
A-16	0.08	27.33	47.60	6.0000	RG-1	J10
A-17	0.09	46.00	17.40	2.0000	RG-1	J17
A-18	0.12	61.50	52.80	2.0000	RG-1	CB08
A-19	0.09	45.00	81.60	2.0000	RG-1	CBMH04
A-20	0.06	30.50	75.70	2.0000	RG-1	CBMH07
A-21	0.20	204.00	0.00	2.0000	RG-1	OF4
A-22	0.06	55.00	0.00	2.0000	RG-1	Woodroffe_Ditch
A-23	0.03	16.67	22.90	2.0000	RG-1	Woodroffe_Ditch
A-24	0.02	23.00	20.40	2.0000	RG-1	RY08
A-25	0.05	36.00	64.30	1.0000	RG-1	RY06
A-26	0.02	22.84	43.50	2.0000	RG-1	CBMH10
A-27	0.01	14.54	78.60	2.0000	RG-1	RY09
A-28	0.01	14.53	78.60	2.0000	RG-1	RY10
A-29	0.02	15.78	66.70	2.0000	RG-1	CBMH09
A-30	0.01	13.35	76.90	2.0000	RG-1	CBMH11
A-31	0.01	14.59	77.90	2.0000	RG-1	RY11
A-32	0.01	14.54	77.90	2.0000	RG-1	RY12
A-33	0.02	15.16	73.30	2.0000	RG-1	RY13
A-34	0.01	14.53	78.60	2.0000	RG-1	RY14
A-35	0.01	14.80	66.70	2.0000	RG-1	CBMH12
EX-01	0.14	68.50	57.10	2.0000	RG-1	J26
EX-02	0.08	39.00	57.10	2.0000	RG-1	J24
EX-03	0.09	44.50	57.10	2.0000	RG-1	J23
EX-04	0.07	33.50	57.10	2.0000	RG-1	J28
EX-05	0.17	84.00	57.10	2.0000	RG-1	J29
EX-06	0.18	120.00	57.10	1.0000	RG-1	EX_06_S
EX-07	0.35	175.00	57.10	2.0000	RG-1	J31
EX-08	0.46	230.00	57.10	2.0000	RG-1	J32
EX-09	0.42	210.00	57.10	2.0000	RG-1	J33
EX-10	0.15	75.00	57.10	2.0000	RG-1	J34
EX-11	0.15	75.00	57.10	2.0000	RG-1	J35
EX-12	5.80	1305.13	64.30	1.0000	RG-1	EX-12_S
EX-13	0.36	180.00	57.10	2.0000	RG-1	J36
EX-14	0.41	205.00	57.10	2.0000	RG-1	J37
EX-15	0.51	340.00	57.10	1.0000	RG-1	EX_15_S

 Node Summary

Name	Type	Invert Elev.	Max. Depth	Pondd Area	External Inflow
208_(EX_STM)	JUNCTION	98.41	3.96	0.0	
CB02-Dummy	JUNCTION	101.72	2.84	0.0	
CB02-Dummy2	JUNCTION	101.52	3.04	0.0	
CB03-Dummy	JUNCTION	101.79	2.84	0.0	
CB03-Dummy2	JUNCTION	100.89	3.74	0.0	
CB04-Dummy	JUNCTION	101.71	2.84	0.0	
CB05-Dummy	JUNCTION	101.71	2.84	0.0	
CB05-Dummy2	JUNCTION	101.60	2.95	0.0	
CB06-Dummy	JUNCTION	101.68	2.84	0.0	
CB07	JUNCTION	102.07	1.00	0.0	
CB08	JUNCTION	101.24	1.00	0.0	
CB09/10	JUNCTION	102.11	1.00	0.0	
CBMH02-Dummy	JUNCTION	100.63	4.00	0.0	
CBMH03-Dummy	JUNCTION	100.27	4.46	0.0	
CBMH04-Dummy	JUNCTION	100.24	4.50	0.0	
Dummy01	JUNCTION	99.99	3.89	0.0	
HP03	JUNCTION	101.89	1.00	0.0	
J1	JUNCTION	101.88	1.00	0.0	
J10	JUNCTION	103.01	1.00	0.0	
J11	JUNCTION	103.93	1.00	0.0	
J12	JUNCTION	103.94	1.00	0.0	
J13	JUNCTION	103.93	1.00	0.0	
J14	JUNCTION	103.87	1.00	0.0	
J15	JUNCTION	103.86	1.00	0.0	
J16	JUNCTION	103.91	1.00	0.0	
J17	JUNCTION	102.23	1.00	0.0	
J18	JUNCTION	101.79	1.00	0.0	
J19	JUNCTION	103.90	1.00	0.0	
J2	JUNCTION	103.82	1.00	0.0	
J20	JUNCTION	103.94	1.00	0.0	
J21	JUNCTION	103.94	1.00	0.0	
J22	JUNCTION	101.67	2.84	0.0	
J23	JUNCTION	101.24	1.00	0.0	
J24	JUNCTION	100.13	1.00	0.0	
J25	JUNCTION	103.94	1.00	0.0	
J26	JUNCTION	97.55	1.00	0.0	
J27	JUNCTION	102.07	1.00	0.0	
J28	JUNCTION	102.23	1.00	0.0	
J29	JUNCTION	102.23	1.00	0.0	
J3	JUNCTION	103.83	1.00	0.0	
J30	JUNCTION	101.86	1.00	0.0	
J31	JUNCTION	101.32	1.00	50.0	
J32	JUNCTION	100.77	1.00	50.0	
J33	JUNCTION	99.58	1.00	50.0	
J34	JUNCTION	99.05	1.00	50.0	
J35	JUNCTION	98.53	1.00	50.0	
J36	JUNCTION	97.55	1.00	50.0	
J37	JUNCTION	95.35	1.00	50.0	
J4	JUNCTION	103.85	1.00	0.0	
J5	JUNCTION	103.85	1.00	0.0	
J6	JUNCTION	103.88	1.00	0.0	
J7	JUNCTION	103.90	1.00	0.0	
J8	JUNCTION	103.95	1.00	0.0	
J9	JUNCTION	103.93	1.00	0.0	
1950mm_STM	OUTFALL	87.11	5.73	0.0	
OF1	OUTFALL	101.75	1.00	0.0	
OF2	OUTFALL	97.45	1.00	0.0	
OF3	OUTFALL	101.72	1.00	0.0	
OF4	OUTFALL	101.00	0.00	0.0	
OF5	OUTFALL	95.24	1.00	0.0	
OF6	OUTFALL	101.77	1.00	0.0	
OF7	OUTFALL	103.58	1.00	0.0	
OF8	OUTFALL	103.83	1.00	0.0	
SU5	OUTFALL	93.77	0.27	0.0	
Woodroffe_Ditch	OUTFALL	101.00	1.00	0.0	
201_(EX_STM)	STORAGE	99.11	2.91	0.0	
202_(EX_STM)	STORAGE	98.45	3.71	0.0	
203_(EX_STM)	STORAGE	97.73	3.77	0.0	
204_(EX_STM)	STORAGE	97.58	3.92	0.0	
205_(EX_STM)	STORAGE	97.31	4.06	0.0	
206_(EX_STM)	STORAGE	97.06	3.74	0.0	
207_(EX_STM)	STORAGE	96.00	3.60	0.0	
209_(EX_STM)	STORAGE	96.02	5.28	0.0	
211	STORAGE	99.26	3.03	0.0	
212	STORAGE	99.62	4.16	0.0	
213	STORAGE	99.76	4.02	0.0	

3400 Woodroffe Avenue (124147)
PCSWMM Model Output
100yr 3-hour Chicago Storm



214	STORAGE	100.14	3.76	0.0
215	STORAGE	99.79	4.11	0.0
216	STORAGE	100.06	3.79	0.0
217	STORAGE	100.16	3.73	0.0
CB01	STORAGE	101.66	2.85	0.0
CB02	STORAGE	101.52	3.04	0.0
CB03	STORAGE	100.89	3.74	0.0
CB04	STORAGE	101.70	2.85	0.0
CB05	STORAGE	101.60	2.95	0.0
CB06	STORAGE	101.67	2.85	0.0
CBMH01	STORAGE	100.70	3.85	0.0
CBMH02	STORAGE	100.63	4.00	0.0
CBMH03	STORAGE	100.27	4.46	0.0
CBMH04	STORAGE	100.24	4.50	0.0
CBMH05	STORAGE	100.80	3.85	0.0
CBMH06	STORAGE	100.55	4.10	0.0
CBMH07	STORAGE	101.10	3.50	0.0
CBMH08	STORAGE	100.82	3.75	0.0
CBMH09	STORAGE	100.43	4.22	0.0
CBMH10	STORAGE	102.00	2.50	0.0
CBMH11	STORAGE	100.44	4.51	0.0
CBMH12	STORAGE	102.28	2.50	0.0
Dummy02	STORAGE	99.96	3.93	0.0
EX_06_S	STORAGE	100.42	2.40	0.0
EX_15_S	STORAGE	99.87	2.40	0.0
EX_MH1	STORAGE	94.15	4.95	0.0
EX_MH2	STORAGE	93.87	4.73	0.0
EX_MH3	STORAGE	92.80	4.80	0.0
EX-12_S	STORAGE	98.15	2.40	0.0
LCB01	STORAGE	102.86	2.00	0.0
LCB02	STORAGE	102.98	2.00	0.0
RY01	STORAGE	100.61	1.91	0.0
RY02	STORAGE	100.37	2.15	0.0
RY03	STORAGE	100.42	2.02	0.0
RY04	STORAGE	100.69	1.81	0.0
RY05	STORAGE	102.40	2.46	0.0
RY06	STORAGE	102.38	2.34	0.0
RY07	STORAGE	102.90	1.92	0.0
RY08	STORAGE	102.39	2.40	0.0
RY09	STORAGE	102.55	2.40	0.0
RY10	STORAGE	102.52	2.40	0.0
RY11	STORAGE	102.54	2.40	0.0
RY12	STORAGE	102.56	2.40	0.0
RY13	STORAGE	102.52	2.40	0.0
RY14	STORAGE	102.52	2.40	0.0

 Link Summary

Name	From Node	To Node	Type	Length	%Slope	Roughness
201-202	201_(EX_STM)	202_(EX_STM)	CONDUIT	83.2	0.7452	0.0130
211-201	211	201_(EX_STM)	CONDUIT	15.6	0.7051	0.0130
212-211	212	211	CONDUIT	34.7	1.0087	0.0130
213-212	213	212	CONDUIT	26.8	0.2985	0.0130
214-Dummy	214	Dummy01	CONDUIT	35.8	0.4190	0.0130
215-212	215	212	CONDUIT	43.9	0.2506	0.0130
216-Dummy	216	Dummy02	CONDUIT	34.0	0.2941	0.0130
217-216	217	216	CONDUIT	11.0	0.3636	0.0130
C1	CB05-Dummy2	213	CONDUIT	20.7	1.0145	0.0130
C10	J6	CBMH01	CONDUIT	3.0	11.0672	0.0150
C11	J11	CB04	CONDUIT	3.0	12.7695	0.0150
C12	CBMH05	J7	CONDUIT	3.0	-8.3624	0.0150
C13	J7	CB04	CONDUIT	3.0	11.7469	0.0150
C14	CBMH01	J5	CONDUIT	3.0	-10.0504	0.0150
C15	J5	CB06	CONDUIT	3.0	11.0672	0.0150
C16	CB05	J4	CONDUIT	3.0	-10.0504	0.0150
C17	J4	CB06	CONDUIT	3.0	11.0672	0.0150
C18	CB06	J2	CONDUIT	3.0	-10.0504	0.0150
C19	J2	J10	CONDUIT	14.8	5.4812	0.0150
C2	CBMH02-Dummy	214	CONDUIT	18.3	0.9837	0.0130
C20	RY05	J8	CONDUIT	3.0	-3.0014	0.0350
C21	J8	CBMH02	CONDUIT	3.0	10.7279	0.0150
C22	CB02-Dummy2	215	CONDUIT	20.3	0.9853	0.0130
C23	CBMH04	J12	CONDUIT	3.0	-6.6815	0.0150
C24	J12	CBMH07	CONDUIT	3.0	10.3889	0.0150
C25	CB03	J13	CONDUIT	3.0	-10.0504	0.0150
C26	J13	CBMH07	CONDUIT	3.0	11.0672	0.0150
C27	CBMH08	J14	CONDUIT	3.0	-10.0504	0.0150
C28	J14	CB02	CONDUIT	3.0	10.3889	0.0150
C29	J16	CBMH08	CONDUIT	3.0	11.4068	0.0150

C3	CBMH04-Dummy	217	CONDUIT	12.5	0.6400	0.0130
C30	CB02	J15	CONDUIT	3.0	-10.0504	0.0150
C31	J15	CB01	CONDUIT	3.0	11.7469	0.0150
C32	CB01	J3	CONDUIT	3.0	-10.7279	0.0150
C33	J3	CB06	CONDUIT	3.0	10.3889	0.0150
C34	CB09/10	CB08	CONDUIT	67.1	1.2967	0.0150
C35	J17	CB07	CONDUIT	44.2	0.3620	0.0150
C36	CB07	CB08	CONDUIT	70.5	1.1774	0.0150
C37	CB08	Woodroffe_Ditch	CONDUIT	3.0	8.0257	0.0150
C38	CBMH06	J16	CONDUIT	3.0	-8.6994	0.0150
C39	J1	RY03	CONDUIT	21.4	1.8227	0.0350
C4	CB03-Dummy2	216	CONDUIT	15.8	1.0127	0.0130
C40	HP03	RY03	CONDUIT	28.7	1.3939	0.0350
C41	HP03	RY02	CONDUIT	22.3	1.5248	0.0350
C42	RY01	J18	CONDUIT	18.5	-1.1352	0.0350
C43	RY07	J20	CONDUIT	3.0	-4.0032	0.0350
C44	RY04	OF3	CONDUIT	1.0	-22.5525	0.0350
C45	LCB02	RY06	CONDUIT	25.2	0.9921	0.0130
C46	J18	RY02	CONDUIT	21.6	1.1112	0.0350
C47	J20	RY08	CONDUIT	3.0	5.0063	0.0350
C48	RY08	J21	CONDUIT	3.0	-5.0063	0.0350
C49	J21	CBMH01	CONDUIT	3.0	13.1113	0.0150
C5	J10	CB09/10	CONDUIT	14.8	6.9924	0.0150
C50	LCB01	RY05	CONDUIT	1.7	1.1766	0.0130
C51	J1	RY04	CONDUIT	22.7	1.6742	0.0350
C52	RY06	J25	CONDUIT	2.0	-11.0672	0.0350
C53	J25	CB02	CONDUIT	5.0	7.6220	0.0150
C54	CBMH10	CBMH09	CONDUIT	50.1	0.4990	0.0130
C55	RY09	CBMH09	CONDUIT	2.0	1.0001	0.0130
C56	RY10	CBMH09	CONDUIT	2.0	1.0001	0.0130
C57	CBMH12	CBMH11	CONDUIT	66.2	0.4985	0.0130
C58	RY14	CBMH12	CONDUIT	2.0	1.0001	0.0130
C59	CBMH07	J19	CONDUIT	3.0	-10.0504	0.0150
C6	CBMH03	J11	CONDUIT	3.0	-6.6815	0.0150
C60	J19	CBMH08	CONDUIT	3.0	11.0672	0.0150
C61	RY13	CBMH12	CONDUIT	2.0	1.0001	0.0130
C62	RY11	CBMH11	CONDUIT	2.0	1.0001	0.0130
C63	RY12	CBMH11	CONDUIT	2.0	1.0001	0.0130
C64	209_(EX_STM)	SU5	CONDUIT	73.4	3.0396	0.0130
C65	202_(EX_STM)	203_(EX_STM)	CONDUIT	113.0	0.6372	0.0130
C66	203_(EX_STM)	204_(EX_STM)	CONDUIT	9.3	0.7527	0.0130
C67	204_(EX_STM)	205_(EX_STM)	CONDUIT	39.4	0.3553	0.0130
C68	205_(EX_STM)	206_(EX_STM)	CONDUIT	85.8	0.2914	0.0130
C69	206_(EX_STM)	207_(EX_STM)	CONDUIT	120.1	0.4246	0.0130
C7	CBMH02	J9	CONDUIT	3.0	-10.0504	0.0150
C70	207_(EX_STM)	EX_MH1	CONDUIT	51.8	1.0232	0.0130
C71	EX_MH1	EX_MH2	CONDUIT	30.0	0.7667	0.0130
C72	EX_MH2	EX_MH3	CONDUIT	120.0	0.8500	0.0130
C73	EX_MH3	1950mm_STM	CONDUIT	96.5	0.7461	0.0130
C74	J28	J27	CONDUIT	44.2	0.3620	0.0150
C75	J27	J23	CONDUIT	70.0	1.1858	0.0150
C76	J23	J24	CONDUIT	40.6	2.7350	0.0150
C77	J24	J26	CONDUIT	76.1	3.3922	0.0150
C78	J26	OF2	CONDUIT	10.0	1.0001	0.0150
C79	J29	J30	CONDUIT	92.7	0.3991	0.0150
C8	J9	CB04	CONDUIT	3.0	12.7695	0.0150
C80	J30	J31	CONDUIT	84.1	0.6421	0.0150
C81	J31	J32	CONDUIT	86.3	0.6373	0.0150
C82	J32	J33	CONDUIT	118.8	1.0017	0.0150
C83	J33	J34	CONDUIT	53.1	0.9982	0.0150
C84	J34	J35	CONDUIT	51.7	1.0059	0.0150
C85	J35	J36	CONDUIT	98.2	0.9980	0.0150
C86	J36	J37	CONDUIT	73.3	3.0027	0.0150
C87	J37	OF5	CONDUIT	11.5	0.9566	0.0150
C88	RY03	OF1	CONDUIT	1.0	-32.6063	0.0350
C89	RY02	OF6	CONDUIT	1.0	-25.8199	0.0350
C9	CB04	J6	CONDUIT	3.0	-11.0672	0.0150
C90	CBMH10	OF7	CONDUIT	1.0	-8.0257	0.0350
C91	CBMH12	OF8	CONDUIT	1.0	-5.0063	0.0350
C92	EX-12_S	J35	CONDUIT	3.0	48.9979	0.0150
CB01-Storage	J22	CB01	CONDUIT	8.9	0.1117	0.0130
CB02-Storage	CB02-Dummy	CB02	CONDUIT	8.1	0.1235	0.0130
CB03-Storage	CB03-Dummy	CB03	CONDUIT	4.0	0.2500	0.0130
CB04-Storage	CB04-Dummy	CB04	CONDUIT	4.0	0.2500	0.0130
CB05-Storage	CB05-Dummy	CB05	CONDUIT	5.8	0.1724	0.0130
CB06-Storage	CB06-Dummy	CB06	CONDUIT	4.0	0.2500	0.0130
CBMH03-214	CBMH03-Dummy	214	CONDUIT	19.0	0.3158	0.0130
dummy-213	Dummy01	213	CONDUIT	43.2	0.3935	0.0130
Dummy-215	Dummy02	215	CONDUIT	35.4	0.3107	0.0130
EX_STM-16_(EX_STM)	208_(EX_STM)	209_(EX_STM)	CONDUIT	74.0	3.1908	0.0130
RY01-RY02	RY01	RY02	CONDUIT	36.7	0.4905	0.0130
RY04-RY03	RY04	RY03	CONDUIT	43.4	0.4839	0.0130

3400 Woodroffe Avenue (124147)
PCSWMM Model Output
100yr 3-hour Chicago Storm



RY05-CBMH02	RY05	CBMH02	CONDUIT	11.5	1.5654	0.0130
RY06-CB02	RY06	CB02-Dummy	CONDUIT	12.6	1.0318	0.0130
ry07-ry05	RY07	RY05	CONDUIT	48.0	1.0001	0.0130
0-CB01	CB01	215	ORIFICE			
0-CB02	CB02	CB02-Dummy2	ORIFICE			
0-CB03	CB03	CB03-Dummy2	ORIFICE			
0-CB04	CB04	214	ORIFICE			
0-CB05	CB05	CB05-Dummy2	ORIFICE			
0-CB06	CB06	213	ORIFICE			
0-CBMH01	CBMH01	Dummy01	ORIFICE			
0-CBMH02	CBMH02	CBMH02-Dummy	ORIFICE			
0-CBMH03	CBMH03	CBMH03-Dummy	ORIFICE			
0-CBMH04	CBMH04	CBMH04-Dummy	ORIFICE			
0-CBMH05	CBMH05	Dummy01	ORIFICE			
0-CBMH06	CBMH06	Dummy02	ORIFICE			
0-CBMH07	CBMH07	216	ORIFICE			
0-CBMH08	CBMH08	Dummy02	ORIFICE			
0-CBMH09	CBMH09	211	ORIFICE			
0-CBMH11	CBMH11	211	ORIFICE			
OR3	EX-12_S	EX_MH1	ORIFICE			
OR4	EX_06_S	204_(EX_STM)	ORIFICE			
OR5	EX_15_S	206_(EX_STM)	ORIFICE			
0-RY02	RY02	217	ORIFICE			
0-ry03	RY03	214	ORIFICE			
0-RY08	RY08	213	ORIFICE			
0-CB07	CB07	201_(EX_STM)	OUTLET			
0-CB08	CB08	208_(EX_STM)	OUTLET			
0-CB09/CB10	CB09/10	211	OUTLET			
OL1	J23	208_(EX_STM)	OUTLET			
OL10	J35	EX_MH2	OUTLET			
OL11	J26	EX_MH3	OUTLET			
OL12	J37	EX_MH3	OUTLET			
OL2	J24	209_(EX_STM)	OUTLET			
OL3	J26	209_(EX_STM)	OUTLET			
OL4	J27	201_(EX_STM)	OUTLET			
OL5	J30	203_(EX_STM)	OUTLET			
OL6	J31	205_(EX_STM)	OUTLET			
OL7	J32	206_(EX_STM)	OUTLET			
OL8	J33	207_(EX_STM)	OUTLET			
OL9	J34	EX_MH1	OUTLET			

Cross Section Summary

Conduit	Shape	Full Depth	Full Area	Hyd. Rad.	Max. Width	No. of Barrels	Full Flow
201-202	CIRCULAR	0.45	0.16	0.11	0.45	1	246.13
211-201	CIRCULAR	0.45	0.16	0.11	0.45	1	239.43
212-211	CIRCULAR	0.45	0.16	0.11	0.45	1	286.36
213-212	CIRCULAR	0.45	0.16	0.11	0.45	1	155.78
214-Dummy	CIRCULAR	0.38	0.11	0.09	0.38	1	113.50
215-212	CIRCULAR	0.45	0.16	0.11	0.45	1	142.72
216-Dummy	CIRCULAR	0.30	0.07	0.07	0.30	1	52.45
217-216	CIRCULAR	0.30	0.07	0.07	0.30	1	58.32
C1	CIRCULAR	0.30	0.07	0.07	0.30	1	97.41
C10	RECT_OPEN	1.00	3.00	0.60	3.00	1	47334.20
C11	RECT_OPEN	1.00	3.00	0.60	3.00	1	50844.53
C12	RECT_OPEN	1.00	3.00	0.60	3.00	1	41145.56
C13	RECT_OPEN	1.00	3.00	0.60	3.00	1	48766.13
C14	RECT_OPEN	1.00	3.00	0.60	3.00	1	45107.44
C15	RECT_OPEN	1.00	3.00	0.60	3.00	1	47334.20
C16	RECT_OPEN	1.00	6.00	0.75	6.00	1	104685.09
C17	RECT_OPEN	1.00	3.00	0.60	3.00	1	47334.20
C18	RECT_OPEN	1.00	3.00	0.60	3.00	1	45107.44
C19	Pvt_Ent	1.00	9.47	0.01	10.30	1	7587.27
C2	CIRCULAR	0.30	0.07	0.07	0.30	1	95.91
C20	TRAPEZOIDAL	1.00	3.15	0.49	6.15	1	9645.56
C21	RECT_OPEN	1.00	3.00	0.60	3.00	1	46602.99
C22	CIRCULAR	0.30	0.07	0.07	0.30	1	95.99
C23	RECT_OPEN	1.00	3.00	0.60	3.00	1	36778.58
C24	RECT_OPEN	1.00	3.00	0.60	3.00	1	45860.92
C25	RECT_OPEN	1.00	3.00	0.60	3.00	1	45107.44
C26	RECT_OPEN	1.00	3.00	0.60	3.00	1	47334.20
C27	RECT_OPEN	1.00	3.00	0.60	3.00	1	45107.44
C28	RECT_OPEN	1.00	3.00	0.60	3.00	1	45860.92
C29	RECT_OPEN	1.00	3.00	0.60	3.00	1	48055.09
C3	CIRCULAR	0.30	0.07	0.07	0.30	1	77.37
C30	RECT_OPEN	1.00	3.00	0.60	3.00	1	45107.44
C31	RECT_OPEN	1.00	3.00	0.60	3.00	1	48766.13
C32	RECT_OPEN	1.00	3.00	0.60	3.00	1	46602.99

C33	RECT_OPEN	1.00	3.00	0.60	3.00	1	45860.92
C34	Pvt_Ent	1.00	9.47	0.01	10.30	1	3690.33
C35	Woodroffe_West	1.00	10.93	0.35	13.00	1	21575.31
C36	Woodroffe_West	1.00	10.93	0.35	13.00	1	38910.45
C37	Woodroffe_West	1.00	10.93	0.35	13.00	1	101589.49
C38	RECT_OPEN	1.00	3.00	0.60	3.00	1	41966.39
C39	TRAPEZOIDAL	1.00	3.30	0.50	6.30	1	7999.66
C4	CIRCULAR	0.30	0.07	0.07	0.30	1	97.32
C40	TRAPEZOIDAL	1.00	3.30	0.50	6.30	1	6995.53
C41	TRAPEZOIDAL	1.00	3.30	0.50	6.30	1	7316.82
C42	TRAPEZOIDAL	1.00	3.30	0.50	6.30	1	6313.18
C43	TRAPEZOIDAL	1.00	3.30	0.50	6.30	1	11855.34
C44	TRAPEZOIDAL	1.00	3.30	0.50	6.30	1	28138.95
C45	CIRCULAR	0.25	0.05	0.06	0.25	1	59.24
C46	TRAPEZOIDAL	1.00	3.30	0.50	6.30	1	6246.01
C47	TRAPEZOIDAL	1.00	3.30	0.50	6.30	1	13257.66
C48	TRAPEZOIDAL	1.00	3.30	0.50	6.30	1	13257.66
C49	RECT_OPEN	1.00	3.00	0.60	3.00	1	51520.40
C5	Pvt_Ent	1.00	9.47	0.01	10.30	1	7999.09
C50	CIRCULAR	0.25	0.05	0.06	0.25	1	64.51
C51	TRAPEZOIDAL	1.00	3.30	0.50	6.30	1	7666.89
C52	TRAPEZOIDAL	1.00	3.15	0.49	6.15	1	18521.97
C53	RECT_OPEN	1.00	3.00	0.60	3.00	1	39281.92
C54	CIRCULAR	0.30	0.07	0.07	0.30	1	68.31
C55	CIRCULAR	0.25	0.05	0.06	0.25	1	59.47
C56	CIRCULAR	0.25	0.05	0.06	0.25	1	59.47
C57	CIRCULAR	0.30	0.07	0.07	0.30	1	68.28
C58	CIRCULAR	0.25	0.05	0.06	0.25	1	59.47
C59	RECT_OPEN	1.00	3.00	0.60	3.00	1	45107.44
C6	RECT_OPEN	1.00	3.00	0.60	3.00	1	36778.58
C60	RECT_OPEN	1.00	3.00	0.60	3.00	1	47334.20
C61	CIRCULAR	0.25	0.05	0.06	0.25	1	59.47
C62	CIRCULAR	0.45	0.16	0.11	0.45	1	285.13
C63	CIRCULAR	0.25	0.05	0.06	0.25	1	59.47
C64	CIRCULAR	0.25	0.05	0.06	0.25	1	103.68
C65	CIRCULAR	0.53	0.22	0.13	0.53	1	343.31
C66	CIRCULAR	0.53	0.22	0.13	0.53	1	373.14
C67	CIRCULAR	0.60	0.28	0.15	0.60	1	366.03
C68	CIRCULAR	0.68	0.36	0.17	0.68	1	453.77
C69	CIRCULAR	0.68	0.36	0.17	0.68	1	547.80
C7	RECT_OPEN	1.00	3.00	0.60	3.00	1	45107.44
C70	CIRCULAR	0.68	0.36	0.17	0.68	1	850.34
C71	CIRCULAR	0.76	0.46	0.19	0.76	1	1017.00
C72	CIRCULAR	0.76	0.46	0.19	0.76	1	1070.85
C73	CIRCULAR	0.76	0.46	0.19	0.76	1	1003.28
C74	Woodroff_East	1.00	10.93	0.30	13.00	1	19778.12
C75	Woodroff_East	1.00	10.93	0.30	13.00	1	35796.46
C76	Woodroff_East	1.00	10.93	0.30	13.00	1	54364.38
C77	Woodroff_East	1.00	10.93	0.30	13.00	1	60544.85
C78	Woodroff_East	1.00	10.93	0.30	13.00	1	32873.48
C79	Woodroff_East	1.00	10.93	0.30	13.00	1	20768.14
C8	RECT_OPEN	1.00	3.00	0.60	3.00	1	50844.53
C80	Woodroffe_26m	1.00	21.87	0.35	26.00	1	57469.84
C81	Woodroffe_26m	1.00	21.87	0.35	26.00	1	57255.47
C82	Woodroffe_26m	1.00	21.87	0.35	26.00	1	71781.55
C83	Woodroffe_26m	1.00	21.87	0.35	26.00	1	71653.62
C84	Woodroffe_26m	1.00	21.87	0.35	26.00	1	71929.00
C85	Woodroffe_26m	1.00	21.87	0.35	26.00	1	71648.12
C86	Woodroffe_26m	1.00	21.87	0.35	26.00	1	124277.89
C87	Woodroffe_26m	1.00	21.87	0.35	26.00	1	70144.56
C88	TRAPEZOIDAL	1.00	3.30	0.50	6.30	1	33834.59
C89	TRAPEZOIDAL	1.00	3.30	0.50	6.30	1	30108.38
C9	RECT_OPEN	1.00	3.00	0.60	3.00	1	47334.20
C90	TRAPEZOIDAL	1.00	3.30	0.50	6.30	1	16786.20
C91	TRAPEZOIDAL	1.00	3.30	0.50	6.30	1	13257.66
C92	Woodroffe_26m	1.00	21.87	0.35	26.00	1	502025.03
CB01-Storage	RECT_CLOSED	1.14	2.16	0.36	1.90	1	2782.84
CB02-Storage	RECT_CLOSED	1.14	2.16	0.36	1.90	1	2925.22
CB03-Storage	RECT_CLOSED	1.14	2.16	0.36	1.90	1	4162.66
CB04-Storage	RECT_CLOSED	1.14	2.16	0.36	1.90	1	4162.66
CB05-Storage	RECT_CLOSED	1.14	2.16	0.36	1.90	1	3456.90
CB06-Storage	RECT_CLOSED	1.14	2.16	0.36	1.90	1	4162.66
CBMH03-214	CIRCULAR	0.30	0.07	0.07	0.30	1	54.34
dummy-213	CIRCULAR	0.38	0.11	0.09	0.38	1	109.99
Dummy-215	CIRCULAR	0.38	0.11	0.09	0.38	1	97.74
EX_STM-16_(EX_STM)	CIRCULAR	0.25	0.05	0.06	0.25	1	106.23
RY01-RY02	CIRCULAR	0.45	0.16	0.11	0.45	1	199.68
RY04-RY03	CIRCULAR	0.45	0.16	0.11	0.45	1	198.34
RY05-CBMH02	CIRCULAR	0.25	0.05	0.06	0.25	1	74.41
RY06-CB02	CIRCULAR	0.25	0.05	0.06	0.25	1	60.41
ry07-ry05	CIRCULAR	0.25	0.05	0.06	0.25	1	59.47

**3400 Woodroffe Avenue (124147)
PCSWMM Model Output
100yr 3-hour Chicago Storm**



Transect Summary

Transect Pvt_Ent

Area:

0.0021	0.0085	0.0190	0.0329	0.0471
0.0613	0.0755	0.0905	0.1094	0.1311
0.1528	0.1745	0.1962	0.2179	0.2396
0.2613	0.2830	0.3047	0.3264	0.3482
0.3699	0.3916	0.4133	0.4350	0.4567
0.4785	0.5002	0.5219	0.5436	0.5653
0.5871	0.6088	0.6305	0.6522	0.6740
0.6957	0.7174	0.7392	0.7609	0.7826
0.8044	0.8261	0.8478	0.8696	0.8913
0.9130	0.9348	0.9565	0.9783	1.0000

Hrad:

0.8481	1.6963	2.5444	3.9359	5.6120
7.2781	8.9342	0.1423	0.1454	0.1637
0.1854	0.2076	0.2301	0.2526	0.2752
0.2978	0.3203	0.3427	0.3650	0.3873
0.4094	0.4314	0.4533	0.4751	0.4968
0.5183	0.5397	0.5610	0.5822	0.6032
0.6242	0.6450	0.6657	0.6862	0.7067
0.7270	0.7472	0.7673	0.7873	0.8072
0.8270	0.8466	0.8662	0.8856	0.9049
0.9242	0.9433	0.9623	0.9812	1.0000

Width:

0.1944	0.3889	0.5833	0.6515	0.6518
0.6520	0.6523	0.7761	0.9691	0.9981
0.9981	0.9982	0.9982	0.9983	0.9983
0.9984	0.9984	0.9985	0.9985	0.9986
0.9986	0.9987	0.9987	0.9988	0.9988
0.9989	0.9989	0.9990	0.9990	0.9990
0.9991	0.9991	0.9992	0.9992	0.9993
0.9993	0.9994	0.9994	0.9995	0.9995
0.9996	0.9996	0.9997	0.9997	0.9998
0.9998	0.9999	0.9999	1.0000	1.0000

Transect Woodroff_East

Area:

0.0006	0.0025	0.0056	0.0100	0.0155
0.0224	0.0305	0.0401	0.0525	0.0673
0.0838	0.1022	0.1224	0.1444	0.1680
0.1917	0.2155	0.2393	0.2630	0.2868
0.3106	0.3343	0.3581	0.3819	0.4056
0.4294	0.4532	0.4769	0.5007	0.5245
0.5483	0.5720	0.5958	0.6196	0.6433
0.6671	0.6909	0.7147	0.7384	0.7622
0.7860	0.8098	0.8335	0.8573	0.8811
0.9049	0.9287	0.9524	0.9762	1.0000

Hrad:

0.0324	0.0647	0.0971	0.1294	0.1618
0.1942	0.2265	0.2568	0.2793	0.3153
0.3420	0.3617	0.3762	0.3868	0.3957
0.4074	0.4211	0.4362	0.4523	0.4690
0.4862	0.5037	0.5215	0.5394	0.5575
0.5756	0.5938	0.6121	0.6303	0.6485
0.6667	0.6849	0.7030	0.7210	0.7390
0.7570	0.7748	0.7926	0.8104	0.8280
0.8456	0.8631	0.8805	0.8978	0.9151
0.9322	0.9493	0.9663	0.9832	1.0000

Width:

0.0523	0.1046	0.1569	0.2092	0.2615
0.3138	0.3662	0.4602	0.5806	0.6574
0.7342	0.8110	0.8879	0.9647	0.9992
0.9993	0.9993	0.9993	0.9993	0.9994
0.9994	0.9994	0.9994	0.9994	0.9995
0.9995	0.9995	0.9995	0.9995	0.9996
0.9996	0.9996	0.9996	0.9997	0.9997
0.9997	0.9997	0.9997	0.9998	0.9998
0.9998	0.9998	0.9998	0.9999	0.9999
0.9999	0.9999	1.0000	1.0000	1.0000

Transect Woodroffe_26m

Area:

0.0006	0.0025	0.0056	0.0100	0.0155
0.0224	0.0305	0.0401	0.0525	0.0673
0.0838	0.1022	0.1224	0.1444	0.1680
0.1917	0.2155	0.2393	0.2630	0.2868
0.3106	0.3343	0.3581	0.3819	0.4056

0.4294	0.4532	0.4769	0.5007	0.5245
0.5483	0.5720	0.5958	0.6196	0.6433
0.6671	0.6909	0.7147	0.7384	0.7622
0.7860	0.8098	0.8335	0.8573	0.8811
0.9049	0.9287	0.9524	0.9762	1.0000

Hrad:

0.0284	0.0568	0.0852	0.1136	0.1420
0.1704	0.1988	0.2240	0.2449	0.2781
0.3031	0.3220	0.3362	0.3470	0.3564
0.3682	0.3819	0.3970	0.4129	0.4296
0.4468	0.4643	0.4822	0.5004	0.5188
0.5373	0.5560	0.5748	0.5937	0.6126
0.6317	0.6508	0.6700	0.6892	0.7085
0.7278	0.7471	0.7665	0.7858	0.8052
0.8247	0.8441	0.8635	0.8830	0.9025
0.9220	0.9415	0.9610	0.9805	1.0000

Width:

0.0523	0.1046	0.1569	0.2092	0.2615
0.3138	0.3662	0.4602	0.5806	0.6574
0.7342	0.8110	0.8879	0.9647	0.9992
0.9993	0.9993	0.9993	0.9993	0.9994
0.9994	0.9994	0.9994	0.9994	0.9995
0.9995	0.9995	0.9995	0.9995	0.9996
0.9996	0.9996	0.9996	0.9997	0.9997
0.9997	0.9997	0.9997	0.9997	0.9998
0.9998	0.9998	0.9998	0.9999	0.9999
0.9999	0.9999	1.0000	1.0000	1.0000

Transect Woodroffe_West

Area:

0.0006	0.0025	0.0056	0.0100	0.0155
0.0224	0.0305	0.0401	0.0525	0.0673
0.0838	0.1022	0.1224	0.1444	0.1680
0.1917	0.2155	0.2393	0.2630	0.2868
0.3106	0.3343	0.3581	0.3819	0.4056
0.4294	0.4532	0.4769	0.5007	0.5245
0.5483	0.5720	0.5958	0.6196	0.6433
0.6671	0.6909	0.7147	0.7384	0.7622
0.7860	0.8098	0.8335	0.8573	0.8811
0.9049	0.9287	0.9524	0.9762	1.0000

Hrad:

0.0284	0.0568	0.0852	0.1136	0.1420
0.1704	0.1988	0.2240	0.2449	0.2781
0.3031	0.3220	0.3362	0.3470	0.3564
0.3682	0.3819	0.3970	0.4129	0.4296
0.4468	0.4643	0.4822	0.5004	0.5188
0.5373	0.5560	0.5748	0.5937	0.6126
0.6317	0.6508	0.6700	0.6892	0.7085
0.7278	0.7471	0.7665	0.7858	0.8052
0.8247	0.8441	0.8635	0.8830	0.9025
0.9220	0.9415	0.9610	0.9805	1.0000

Width:

0.0523	0.1046	0.1569	0.2092	0.2615
0.3138	0.3662	0.4602	0.5806	0.6574
0.7342	0.8110	0.8879	0.9647	0.9992
0.9993	0.9993	0.9993	0.9993	0.9994
0.9994	0.9994	0.9994	0.9994	0.9995
0.9995	0.9995	0.9995	0.9995	0.9996
0.9996	0.9996	0.9996	0.9997	0.9997
0.9997	0.9997	0.9997	0.9997	0.9998
0.9998	0.9998	0.9998	0.9999	0.9999
0.9999	0.9999	1.0000	1.0000	1.0000

Analysis Options

Flow Units LPS

Process Models:

Rainfall/Runoff YES

RDII NO

Snowmelt NO

Groundwater NO

Flow Routing YES

Ponding Allowed YES

Water Quality NO

Infiltration Method HORTON

Flow Routing Method DYNWAVE

Surcharge Method EXTRAN

Starting Date 06/25/2025 00:00:00

Ending Date 06/26/2025 00:00:00

Antecedent Dry Days 0.0

3400 Woodroffe Avenue (124147)
PCSWMM Model Output
100yr 3-hour Chicago Storm



Report Time Step 00:01:00
Wet Time Step 00:05:00
Dry Time Step 00:05:00
Routing Time Step 0.50 sec
Variable Time Step YES
Maximum Trials 10
Number of Threads 4
Head Tolerance 0.001500 m

	Volume hectare-m	Depth mm
Runoff Quantity Continuity		
Total Precipitation	0.848	71.667
Evaporation Loss	0.000	0.000
Infiltration Loss	0.207	17.465
Surface Runoff	0.644	54.415
Final Storage	0.006	0.510
Continuity Error (%)	-1.010	

	Volume hectare-m	Volume 10^6 ltr
Flow Routing Continuity		
Dry Weather Inflow	0.000	0.000
Wet Weather Inflow	0.644	6.440
Groundwater Inflow	0.000	0.000
RDII Inflow	0.000	0.000
External Inflow	0.004	0.042
External Outflow	0.647	6.469
Flooding Loss	0.000	0.000
Evaporation Loss	0.000	0.000
Exfiltration Loss	0.000	0.000
Initial Stored Volume	0.000	0.002
Final Stored Volume	0.002	0.015
Continuity Error (%)	-0.002	

Time-Step Critical Elements
None

Highest Flow Instability Indexes
Link OL6 (2)
Link OL12 (1)
Link OL7 (1)
Link OL11 (1)
Link OL9 (1)

Most Frequent Nonconverging Nodes
Convergence obtained at all time steps.

Routing Time Step Summary
Minimum Time Step : 0.50 sec
Average Time Step : 0.50 sec
Maximum Time Step : 0.50 sec
% of Time in Steady State : 0.00
Average Iterations per Step : 2.00
% of Steps Not Converging : 0.00
Time Step Frequencies :
0.500 - 0.500 sec : 100.00 %
0.500 - 0.500 sec : 0.00 %
0.500 - 0.500 sec : 0.00 %
0.500 - 0.500 sec : 0.00 %
0.500 - 0.500 sec : 0.00 %

Subcatchment Runoff Summary

Total Runoff Subcatchment 10^6 ltr	Peak Runoff LPS	Runoff Coeff	Total Precip mm	Total Runon mm	Total Evap mm	Total Infil mm	Imperv Runoff mm	Perv Runoff mm	Total Runoff mm
A-01			71.67	0.00	0.00	30.90	41.77	19.55	41.77
A-02	40.46	0.583	71.67	0.00	0.00	27.29	45.34	17.47	45.34
A-03	32.53	0.633	71.67	0.00	0.00	7.36	59.14	5.10	64.24
A-04	55.42	0.896	71.67	0.00	0.00	9.00	56.61	6.19	62.80
A-05	45.91	0.876	71.67	0.00	0.00	8.72	57.03	5.85	62.88
A-06	45.21	0.877	71.67	0.00	0.00	16.54	44.86	10.97	55.83
A-07	35.88	0.779	71.67	0.00	0.00	10.11	54.54	6.89	61.43
A-08	43.69	0.857	71.67	0.00	0.00	8.69	56.72	5.99	62.71
A-09	31.14	0.875	71.67	0.00	0.00	7.03	59.80	5.00	64.80
A-10	43.53	0.904	71.67	0.00	0.00	9.22	56.04	6.33	62.37
A-11	35.34	0.870	71.67	0.00	0.00	8.55	57.34	5.72	63.06
A-12	57.09	0.880	71.67	0.00	0.00	7.78	58.63	5.25	63.88
A-13	76.57	0.891	71.67	0.00	0.00	5.97	61.51	4.29	65.81
A-14	42.75	0.918	71.67	0.00	0.00	7.90	58.22	5.40	63.62
A-15	40.31	0.888	71.67	0.00	0.00	8.95	56.65	5.97	62.62
A-16	56.43	0.874	71.67	0.00	0.00	23.37	33.41	15.06	48.47
A-17	34.54	0.676	71.67	0.00	0.00	37.40	12.21	22.69	34.90
A-18	29.15	0.487	71.67	0.00	0.00	21.07	37.08	13.53	50.60
A-19	52.49	0.706	71.67	0.00	0.00	8.11	58.04	5.62	63.66
A-20	43.25	0.888	71.67	0.00	0.00	10.74	53.50	7.29	60.78
A-21	28.85	0.848	71.67	0.00	0.00	44.68	0.00	28.54	28.54
A-22	69.95	0.398	71.67	0.00	0.00	44.68	0.00	28.54	28.54
A-23	18.86	0.398	71.67	0.00	0.00	34.57	16.07	21.78	37.85
A-24	9.12	0.528	71.67	0.00	0.00	35.41	14.61	23.08	37.70
A-25	9.03	0.526	71.67	0.00	0.00	15.87	45.84	10.39	56.23
A-26	24.37	0.785	71.67	0.00	0.00	25.01	31.17	16.77	47.94
A-27	10.00	0.669	71.67	0.00	0.00	9.40	56.29	6.76	63.05
A-28	6.98	0.880	71.67	0.00	0.00	9.40	56.29	6.76	63.05
A-29	6.97	0.880	71.67	0.00	0.00	14.66	47.80	10.24	58.04
A-30	7.40	0.810	71.67	0.00	0.00	10.15	55.12	7.27	62.38
A-31	6.39	0.870	71.67	0.00	0.00	9.70	55.80	6.97	62.77
A-32	6.99	0.876	71.67	0.00	0.00	9.70	55.80	6.97	62.77
A-33	6.97	0.876	71.67	0.00	0.00	11.74	52.49	8.32	60.81
A-34	7.21	0.849	71.67	0.00	0.00	9.40	56.29	6.76	63.05
A-35	6.98	0.880	71.67	0.00	0.00	14.66	47.80	10.24	58.04
EX-01	6.94	0.810	71.67	0.00	0.00	19.11	40.55	12.38	52.92
0.07	59.91	0.738							

3400 Woodroffe Avenue (124147)
PCSWMM Model Output
100yr 3-hour Chicago Storm

EX-02	34.11	0.738	71.67	0.00	0.00	19.11	40.55	12.38	52.92
EX-03	38.92	0.738	71.67	0.00	0.00	19.11	40.55	12.38	52.92
EX-04	29.30	0.738	71.67	0.00	0.00	19.11	40.55	12.38	52.92
EX-05	73.46	0.738	71.67	0.00	0.00	19.11	40.55	12.38	52.92
EX-06	78.24	0.743	71.67	0.00	0.00	19.13	40.95	12.33	53.28
EX-07	153.04	0.738	71.67	0.00	0.00	19.11	40.55	12.38	52.92
EX-08	201.14	0.738	71.67	0.00	0.00	19.11	40.55	12.38	52.92
EX-09	183.65	0.735	71.67	0.00	0.00	19.11	40.10	12.38	52.48
EX-10	65.59	0.732	71.67	0.00	0.00	19.11	40.10	12.38	52.48
EX-11	65.59	0.732	71.67	0.00	0.00	19.11	40.10	12.38	52.48
EX-12	2338.79	0.773	71.67	0.00	0.00	16.35	45.88	9.54	55.42
EX-13	157.41	0.732	71.67	0.00	0.00	19.11	40.10	12.38	52.48
EX-14	179.28	0.732	71.67	0.00	0.00	19.13	40.95	12.33	53.28
EX-15	221.69	0.743	71.67	0.00	0.00	19.13	40.95	12.33	53.28

Node Depth Summary

Node	Type	Average Depth Meters	Maximum Depth Meters	Maximum HGL Meters	Time of Max Occurrence days hr:min	Reported Max Depth Meters
Z08_(EX_STM)	JUNCTION	0.01	0.10	98.51	0 01:12	0.10
CB02-Dummy	JUNCTION	0.33	2.08	103.80	0 01:42	2.08
CB02-Dummy2	JUNCTION	0.01	0.05	101.57	0 01:43	0.05
CB03-Dummy	JUNCTION	0.19	2.04	103.83	0 01:31	2.04
CB03-Dummy2	JUNCTION	0.01	0.06	100.95	0 01:31	0.06
CB04-Dummy	JUNCTION	0.15	2.02	103.73	0 01:24	2.02
CB05-Dummy	JUNCTION	0.24	2.05	103.76	0 01:33	2.05
CB05-Dummy2	JUNCTION	0.01	0.05	101.65	0 01:34	0.05
CB06-Dummy	JUNCTION	0.17	2.01	103.69	0 01:26	2.01
CB07	JUNCTION	0.00	0.04	102.11	0 01:11	0.04
CB08	JUNCTION	0.00	0.05	101.29	0 01:10	0.05
CB09/10	JUNCTION	0.00	0.03	102.14	0 01:10	0.03
CBMH02-Dummy	JUNCTION	0.01	0.06	100.69	0 01:35	0.06
CBMH03-Dummy	JUNCTION	0.01	0.11	100.38	0 01:10	0.11
CBMH04-Dummy	JUNCTION	0.01	0.08	100.32	0 01:04	0.08
Dummy01	JUNCTION	0.04	0.23	100.22	0 01:28	0.23
HP03	JUNCTION	0.00	0.00	101.89	0 00:00	0.00
J1	JUNCTION	0.00	0.00	101.88	0 00:00	0.00
J10	JUNCTION	0.00	0.03	103.04	0 01:10	0.03
J11	JUNCTION	0.00	0.01	103.94	0 01:12	0.01
J12	JUNCTION	0.00	0.01	103.95	0 01:13	0.00
J13	JUNCTION	0.00	0.00	103.93	0 00:00	0.00
J14	JUNCTION	0.00	0.00	103.87	0 00:00	0.00
J15	JUNCTION	0.00	0.00	103.86	0 00:00	0.00
J16	JUNCTION	0.00	0.00	103.91	0 00:00	0.00
J17	JUNCTION	0.00	0.07	102.30	0 01:10	0.07
J18	JUNCTION	0.00	0.00	101.79	0 00:00	0.00
J19	JUNCTION	0.00	0.00	103.90	0 00:00	0.00
J2	JUNCTION	0.00	0.00	103.82	0 00:00	0.00
J20	JUNCTION	0.00	0.00	103.94	0 00:00	0.00
J21	JUNCTION	0.00	0.00	103.94	0 00:00	0.00
J22	JUNCTION	0.34	2.12	103.79	0 01:42	2.12
J23	JUNCTION	0.00	0.04	101.28	0 01:10	0.04
J24	JUNCTION	0.00	0.05	100.18	0 01:10	0.05
J25	JUNCTION	0.00	0.00	103.94	0 00:00	0.00
J26	JUNCTION	0.00	0.08	97.63	0 01:10	0.08
J27	JUNCTION	0.00	0.04	102.11	0 01:10	0.04
J28	JUNCTION	0.00	0.07	102.30	0 01:10	0.07
J29	JUNCTION	0.01	0.10	102.33	0 01:10	0.10
J3	JUNCTION	0.00	0.00	103.83	0 00:00	0.00
J30	JUNCTION	0.00	0.05	101.91	0 01:11	0.05
J31	JUNCTION	0.00	0.07	101.39	0 01:11	0.07
J32	JUNCTION	0.00	0.08	100.85	0 01:11	0.08

J33	JUNCTION	0.00	0.09	99.67	0 01:11	0.09
J34	JUNCTION	0.00	0.09	99.14	0 01:11	0.09
J35	JUNCTION	0.00	0.10	98.63	0 01:12	0.10
J36	JUNCTION	0.00	0.08	97.63	0 01:12	0.08
J37	JUNCTION	0.00	0.10	95.45	0 01:12	0.10
J4	JUNCTION	0.00	0.00	103.85	0 00:00	0.00
J5	JUNCTION	0.00	0.00	103.85	0 00:00	0.00
J6	JUNCTION	0.00	0.00	103.88	0 00:00	0.00
J7	JUNCTION	0.00	0.00	103.90	0 00:00	0.00
J8	JUNCTION	0.00	0.00	103.95	0 00:00	0.00
J9	JUNCTION	0.00	0.00	103.93	0 00:00	0.00
1950mm_STM	OUTFALL	0.00	0.00	87.11	0 00:00	0.00
OF1	OUTFALL	0.00	0.00	101.75	0 00:00	0.00
OF2	OUTFALL	0.00	0.08	97.53	0 01:10	0.08
OF3	OUTFALL	0.00	0.01	101.73	0 01:23	0.01
OF4	OUTFALL	0.00	0.00	101.00	0 00:00	0.00
OF5	OUTFALL	0.00	0.10	95.34	0 01:12	0.10
OF6	OUTFALL	0.00	0.00	101.77	0 00:00	0.00
OF7	OUTFALL	0.00	0.00	103.58	0 00:00	0.00
OF8	OUTFALL	0.00	0.00	103.83	0 00:00	0.00
SU5	OUTFALL	0.30	0.30	94.07	0 00:00	0.30
Woodroffe_Ditch	OUTFALL	0.00	0.05	101.05	0 01:10	0.05
201_(EX_STM)	STORAGE	0.05	0.29	99.40	0 01:12	0.29
202_(EX_STM)	STORAGE	0.05	0.28	98.73	0 01:12	0.28
203_(EX_STM)	STORAGE	0.05	0.30	98.03	0 01:13	0.30
204_(EX_STM)	STORAGE	0.05	0.32	97.90	0 01:13	0.32
205_(EX_STM)	STORAGE	0.06	0.39	97.70	0 01:14	0.39
206_(EX_STM)	STORAGE	0.06	0.44	97.50	0 01:15	0.44
207_(EX_STM)	STORAGE	0.05	0.37	96.37	0 01:15	0.37
209_(EX_STM)	STORAGE	0.01	0.16	96.18	0 01:12	0.16
211	STORAGE	0.06	0.36	99.62	0 01:12	0.36
212	STORAGE	0.04	0.21	99.83	0 01:22	0.21
213	STORAGE	0.05	0.27	100.03	0 01:18	0.27
214	STORAGE	0.03	0.16	100.30	0 01:23	0.16
215	STORAGE	0.05	0.22	100.01	0 01:58	0.22
216	STORAGE	0.03	0.14	100.20	0 01:57	0.14
217	STORAGE	0.03	0.08	100.24	0 02:15	0.08
CB01	STORAGE	0.35	2.13	103.79	0 01:42	2.13
CB02	STORAGE	0.38	2.28	103.80	0 01:42	2.28
CB03	STORAGE	0.31	2.94	103.83	0 01:31	2.94
CB04	STORAGE	0.16	2.03	103.73	0 01:24	2.03
CB05	STORAGE	0.26	2.16	103.76	0 01:33	2.16
CB06	STORAGE	0.18	2.02	103.69	0 01:26	2.02
CBMH01	STORAGE	0.12	3.00	103.70	0 01:19	3.00
CBMH02	STORAGE	0.47	3.29	103.92	0 01:34	3.29
CBMH03	STORAGE	0.17	3.67	103.94	0 01:12	3.67
CBMH04	STORAGE	0.19	3.71	103.95	0 01:13	3.71
CBMH05	STORAGE	0.19	3.07	103.87	0 01:22	3.07
CBMH06	STORAGE	0.19	3.36	103.91	0 01:22	3.36
CBMH07	STORAGE	0.12	2.67	103.77	0 01:21	2.67
CBMH08	STORAGE	0.14	2.94	103.76	0 01:21	2.94
CBMH09	STORAGE	0.13	2.79	103.22	0 01:22	2.79
CBMH10	STORAGE	0.04	1.23	103.23	0 01:21	1.22
CBMH11	STORAGE	0.21	3.16	103.60	0 01:23	3.16
CBMH12	STORAGE	0.05	1.32	103.60	0 01:24	1.32
Dummy02	STORAGE	0.04	0.19	100.15	0 01:57	0.19
EX_06_S	STORAGE	0.12	1.56	101.98	0 01:25	1.56
EX_15_S	STORAGE	0.14	1.64	101.51	0 01:26	1.64
EX_MH1	STORAGE	0.07	0.88	95.03	0 01:20	0.88
EX_MH2	STORAGE	0.07	0.97	94.84	0 01:20	0.97
EX_MH3	STORAGE	0.08	1.24	94.04	0 01:21	1.24
EX-12_S	STORAGE	0.15	1.69	99.84	0 01:30	1.69
LCB01	STORAGE	0.12	1.06	103.92	0 01:35	1.06
LCB02	STORAGE	0.10	0.82	103.80	0 01:43	0.82
RY01	STORAGE	0.02	1.12	101.73	0 01:20	1.12
RY02	STORAGE	0.04	1.36	101.73	0 01:21	1.36
RY03	STORAGE	0.07	1.31	101.73	0 01:22	1.31
RY04	STORAGE	0.05	1.04	101.73	0 01:23	1.04
RY05	STORAGE	0.19	1.52	103.92	0 01:35	1.52
RY06	STORAGE	0.20	1.42	103.80	0 01:42	1.42
RY07	STORAGE	0.12	1.02	103.92	0 01:35	1.02
RY08	STORAGE	0.02	1.43	103.82	0 01:13	1.43
RY09	STORAGE	0.02	0.67	103.22	0 01:22	0.67
RY10	STORAGE	0.02	0.70	103.22	0 01:22	0.70
RY11	STORAGE	0.04	1.06	103.60	0 01:23	1.06
RY12	STORAGE	0.04	1.04	103.60	0 01:23	1.04
RY13	STORAGE	0.04	1.08	103.60	0 01:24	1.08
RY14	STORAGE	0.04	1.08	103.60	0 01:24	1.08

Node Inflow Summary

3400 Woodroffe Avenue (124147)
 PCSWMM Model Output
 100yr 3-hour Chicago Storm

Node	Type	Maximum Lateral Inflow LPS	Maximum Total Inflow LPS	Time of Max Occurrence days hr:min	Lateral Inflow Volume 10^6 ltr	Total Inflow Volume 10^6 ltr	Flow Balance Error Percent
Z08_(EX_STM)	JUNCTION	0.00	38.80	0 01:06	0	0.0683	-0.043
CB02-Dummy	JUNCTION	0.00	31.42	0 01:04	0	0.0355	-0.853
CB02-Dummy2	JUNCTION	0.00	6.42	0 01:42	0	0.106	-0.003
CB03-Dummy	JUNCTION	0.00	20.15	0 01:04	0	0.005	-11.584
CB03-Dummy2	JUNCTION	0.00	7.30	0 01:31	0	0.0744	-0.003
CB04-Dummy	JUNCTION	0.00	15.62	0 01:04	0	0.00498	-11.459
CB05-Dummy	JUNCTION	0.00	21.72	0 01:04	0	0.00688	-6.811
CB05-Dummy2	JUNCTION	0.00	6.24	0 01:33	0	0.075	-0.003
CB06-Dummy	JUNCTION	0.00	14.90	0 01:04	0	0.00499	-10.980
CB07	JUNCTION	0.00	28.08	0 01:10	0	0.0321	0.258
CB08	JUNCTION	52.49	76.18	0 01:10	0.0622	0.0857	-0.040
CB09/10	JUNCTION	0.00	34.31	0 01:10	0	0.0397	-0.044
CBMH02-Dummy	JUNCTION	0.00	7.72	0 01:34	0	0.104	-0.004
CBMH03-Dummy	JUNCTION	0.00	11.68	0 01:12	0	0.0581	0.033
CBMH04-Dummy	JUNCTION	0.00	10.11	0 01:13	0	0.0556	-0.015
Dummy01	JUNCTION	0.00	61.78	0 01:23	0	0.422	0.142
HP03	JUNCTION	0.00	0.00	0 00:00	0	0.000	ltr
J1	JUNCTION	0.00	0.00	0 00:00	0	0.000	ltr
J10	JUNCTION	34.54	34.54	0 01:10	0.0397	0.0397	0.050
J11	JUNCTION	0.00	22.36	0 01:12	0	0.00221	0.012
J12	JUNCTION	0.00	14.01	0 01:13	0	0.00168	0.017
J13	JUNCTION	0.00	0.00	0 00:00	0	0.000	ltr
J14	JUNCTION	0.00	0.00	0 00:00	0	0.000	ltr
J15	JUNCTION	0.00	0.00	0 00:00	0	0.000	ltr
J16	JUNCTION	0.00	0.00	0 00:00	0	0.000	ltr
J17	JUNCTION	29.15	29.15	0 01:10	0.0321	0.0321	-0.025
J18	JUNCTION	0.00	0.00	0 00:00	0	0.000	ltr
J19	JUNCTION	0.00	0.00	0 00:00	0	0.000	ltr
J2	JUNCTION	0.00	0.00	0 00:00	0	0.000	ltr
J20	JUNCTION	0.00	0.00	0 00:00	0	0.000	ltr
J21	JUNCTION	0.00	0.00	0 00:00	0	0.000	ltr
J22	JUNCTION	0.00	29.67	0 01:04	0	0.0103	-3.974
J23	JUNCTION	38.92	49.87	0 01:10	0.0471	0.0579	-0.044
J24	JUNCTION	34.11	62.97	0 01:10	0.0413	0.0669	-0.007
J25	JUNCTION	0.00	0.00	0 00:00	0	0.000	ltr
J26	JUNCTION	59.91	100.69	0 01:10	0.0725	0.106	0.005
J27	JUNCTION	0.00	28.69	0 01:10	0	0.0355	0.139
J28	JUNCTION	29.30	29.30	0 01:10	0.0355	0.0355	-0.025
J29	JUNCTION	73.46	73.46	0 01:10	0.0889	0.0889	-0.195
J3	JUNCTION	0.00	0.00	0 00:00	0	0.000	ltr
J30	JUNCTION	0.00	71.17	0 01:10	0	0.0891	0.324
J31	JUNCTION	153.04	196.15	0 01:10	0.185	0.225	-0.120
J32	JUNCTION	201.14	302.28	0 01:10	0.243	0.299	-0.100
J33	JUNCTION	183.65	346.28	0 01:10	0.221	0.31	-0.074
J34	JUNCTION	65.59	296.09	0 01:11	0.0787	0.198	-0.175
J35	JUNCTION	65.59	311.42	0 01:11	0.0787	0.208	0.488
J36	JUNCTION	157.41	376.35	0 01:11	0.189	0.325	-0.006
J37	JUNCTION	179.28	419.30	0 01:11	0.215	0.374	-0.165
J4	JUNCTION	0.00	0.00	0 00:00	0	0.000	ltr
J5	JUNCTION	0.00	0.00	0 00:00	0	0.000	ltr
J6	JUNCTION	0.00	0.00	0 00:00	0	0.000	ltr
J7	JUNCTION	0.00	0.00	0 00:00	0	0.000	ltr
J8	JUNCTION	0.00	0.00	0 00:00	0	0.000	ltr
J9	JUNCTION	0.00	0.00	0 00:00	0	0.000	ltr
1950mm_STM	OUTFALL	0.00	1107.28	0 01:21	0	5.94	0.000
OF1	OUTFALL	0.00	0.00	0 00:00	0	0.000	ltr
OF2	OUTFALL	0.00	78.68	0 01:10	0	0.0548	0.000
OF3	OUTFALL	0.00	2.19	0 01:23	0	0.0424	0.000
OF4	OUTFALL	69.95	69.95	0 01:10	0.0582	0.0582	0.000
OF5	OUTFALL	0.00	333.43	0 01:12	0	0.186	0.000
OF6	OUTFALL	0.00	0.00	0 00:00	0	0.000	ltr
OF7	OUTFALL	0.00	0.00	0 00:00	0	0.000	ltr
OF8	OUTFALL	0.00	0.00	0 00:00	0	0.000	ltr
SU5	OUTFALL	0.00	77.60	0 01:12	0	0.153	0.000
Woodroffe_Ditch	OUTFALL	27.98	80.40	0 01:10	0.0252	0.0749	0.000
201_(EX_STM)	STORAGE	0.00	184.77	0 01:11	0	1.25	0.011
202_(EX_STM)	STORAGE	0.00	184.43	0 01:12	0	1.25	0.004
203_(EX_STM)	STORAGE	0.00	203.89	0 01:12	0	1.3	0.013
204_(EX_STM)	STORAGE	0.00	216.30	0 01:13	0	1.39	0.006
205_(EX_STM)	STORAGE	0.00	287.86	0 01:13	0	1.56	0.013
206_(EX_STM)	STORAGE	0.00	416.74	0 01:14	0	2.04	0.014
207_(EX_STM)	STORAGE	0.00	501.14	0 01:15	0	2.24	0.004
209_(EX_STM)	STORAGE	0.00	77.60	0 01:12	0	0.153	0.036
211	STORAGE	0.00	152.52	0 01:12	0	1.2	0.019

212	STORAGE	0.00	126.91	0 01:22	0	1.08	-0.005
213	STORAGE	0.00	78.56	0 01:17	0	0.559	0.012
214	STORAGE	0.00	43.37	0 01:23	0	0.324	0.006
215	STORAGE	0.00	52.91	0 01:58	0	0.524	-0.045
216	STORAGE	0.00	21.91	0 01:57	0	0.211	0.038
217	STORAGE	0.00	26.92	0 01:21	0	0.109	-0.036
CB01	STORAGE	76.57	76.57	0 01:10	0	0.102	0.113
CB02	STORAGE	57.09	85.03	0 01:07	0	0.0757	0.111
CB03	STORAGE	55.42	55.42	0 01:10	0	0.0739	0.0795
CB04	STORAGE	43.69	45.68	0 01:12	0	0.0565	0.0643
CB05	STORAGE	56.43	56.43	0 01:10	0	0.0745	0.0819
CB06	STORAGE	40.31	41.13	0 01:06	0	0.0534	0.0591
CBMH01	STORAGE	31.14	31.14	0 01:10	0	0.0408	0.0408
CBMH02	STORAGE	45.21	77.79	0 01:10	0	0.0597	0.107
CBMH03	STORAGE	45.91	45.91	0 01:10	0	0.0603	0.0603
CBMH04	STORAGE	43.25	43.25	0 01:10	0	0.0573	0.0573
CBMH05	STORAGE	42.75	42.75	0 01:10	0	0.0579	0.0579
CBMH06	STORAGE	43.53	43.53	0 01:10	0	0.0583	0.0583
CBMH07	STORAGE	28.85	28.85	0 01:10	0	0.0371	0.0388
CBMH08	STORAGE	35.34	35.34	0 01:10	0	0.0462	0.0462
CBMH09	STORAGE	7.40	25.37	0 01:04	0.00916	0.0399	-0.181
CBMH10	STORAGE	10.00	22.78	0 01:05	0.0109	0.0125	0.514
CBMH11	STORAGE	6.39	32.90	0 01:04	0.00833	0.0541	-0.253
CBMH12	STORAGE	6.94	32.66	0 01:05	0.00859	0.0276	0.391
Dummy02	STORAGE	0.00	40.27	0 01:57	0	0.316	0.233
EX_06_S	STORAGE	78.24	78.24	0 01:10	0.0959	0.0959	0.004
EX_15_S	STORAGE	221.69	221.69	0 01:10	0.272	0.272	0.003
EX_MH1	STORAGE	0.00	935.12	0 01:16	0	5.52	0.015
EX_MH2	STORAGE	0.00	966.39	0 01:15	0	5.59	0.080
EX_MH3	STORAGE	0.00	1110.93	0 01:18	0	5.94	-0.054
EX_12_S	STORAGE	2338.79	2338.79	0 01:10	3.21	3.21	0.005
LCB01	STORAGE	0.00	7.41	0 01:04	0	0.00127	0.147
LCB02	STORAGE	0.00	24.12	0 01:06	0	0.00158	0.043
RY01	STORAGE	0.00	11.61	0 01:08	0	0.00662	0.408
RY02	STORAGE	32.53	32.53	0 01:10	0.0535	0.0601	-0.046
RY03	STORAGE	40.46	40.46	0 01:15	0.0614	0.111	-0.016
RY04	STORAGE	0.00	13.84	0 01:09	0	0.0507	0.236
RY05	STORAGE	35.88	45.72	0 01:04	0.0441	0.0521	0.294
RY06	STORAGE	24.37	38.63	0 01:06	0.0304	0.0326	0.249
RY07	STORAGE	0.00	24.58	0 01:03	0	0.00362	0.277
RY08	STORAGE	9.03	9.03	0 01:10	0.00867	0.00867	0.002
RY09	STORAGE	6.98	6.98	0 01:10	0.00916	0.00916	-0.001
RY10	STORAGE	6.97	6.97	0 01:10	0.00916	0.00916	-0.001
RY11	STORAGE	6.99	9.20	0 01:06	0.00916	0.00917	-0.002
RY12	STORAGE	6.97	6.97	0 01:10	0.00913	0.00913	0.001
RY13	STORAGE	7.21	7.21	0 01:10	0.00922	0.00922	0.001
RY14	STORAGE	6.98	6.98	0 01:10	0.00916	0.00916	0.001

Node Surcharge Summary

Surcharging occurs when water rises above the top of the highest conduit.

Node	Type	Hours Surcharged	Max. Height Above Crown Meters	Min. Depth Below Rim Meters
CB02-Dummy	JUNCTION	3.59	0.946	0.756
CB03-Dummy	JUNCTION	2.19	0.902	0.800
CB04-Dummy	JUNCTION	1.66	0.886	0.816
CB05-Dummy	JUNCTION	2.60	0.913	0.789
CB06-Dummy	JUNCTION	1.88	0.872	0.830
J22	JUNCTION	3.61	0.985	0.717

Node Flooding Summary

No nodes were flooded.

Storage Volume Summary

Storage Unit	Average Volume 1000 m³	Avg Pcnt Full	Evap Pcnt Loss	Exfill Pcnt Loss	Maximum Volume 1000 m³	Max Pcnt Full	Time of Max Occurrence days hr:min	Maximum Outflow LPS
--------------	------------------------	---------------	----------------	------------------	------------------------	---------------	------------------------------------	---------------------

**3400 Woodroffe Avenue (124147)
PCSWMM Model Output
100yr 3-hour Chicago Storm**



201_(EX_STM)	0.000	1.6	0.0	0.0	0.000	10.0	0	01:12	184.43
202_(EX_STM)	0.000	1.3	0.0	0.0	0.000	7.4	0	01:12	184.49
203_(EX_STM)	0.000	1.3	0.0	0.0	0.001	7.8	0	01:13	203.53
204_(EX_STM)	0.000	1.4	0.0	0.0	0.001	8.3	0	01:13	216.36
205_(EX_STM)	0.000	1.4	0.0	0.0	0.001	9.6	0	01:14	287.73
206_(EX_STM)	0.000	1.5	0.0	0.0	0.001	11.7	0	01:15	415.34
207_(EX_STM)	0.000	1.3	0.0	0.0	0.001	10.4	0	01:15	501.19
209_(EX_STM)	0.000	0.1	0.0	0.0	0.000	3.1	0	01:12	77.60
211	0.000	1.9	0.0	0.0	0.000	11.9	0	01:12	152.46
212	0.000	1.0	0.0	0.0	0.000	5.0	0	01:22	126.91
213	0.000	1.1	0.0	0.0	0.000	6.7	0	01:18	78.53
214	0.000	0.9	0.0	0.0	0.000	4.3	0	01:23	43.37
215	0.000	1.2	0.0	0.0	0.000	5.3	0	01:58	52.89
216	0.000	0.8	0.0	0.0	0.000	3.6	0	01:57	21.90
217	0.026	0.7	0.0	0.0	0.081	2.2	0	02:15	7.10
CB01	0.003	6.6	0.0	0.0	0.036	78.4	0	01:42	34.23
CB02	0.003	5.4	0.0	0.0	0.034	66.3	0	01:42	29.75
CB03	0.001	2.4	0.0	0.0	0.025	45.6	0	01:31	26.19
CB04	0.001	1.2	0.0	0.0	0.015	31.9	0	01:24	21.25
CB05	0.001	3.0	0.0	0.0	0.024	50.3	0	01:33	26.44
CB06	0.001	1.4	0.0	0.0	0.013	33.1	0	01:26	19.46
CBMH01	0.000	0.9	0.0	0.0	0.012	32.8	0	01:19	9.16
CBMH02	0.004	7.5	0.0	0.0	0.046	91.5	0	01:34	24.76
CBMH03	0.001	3.1	0.0	0.0	0.020	100.0	0	01:12	34.04
CBMH04	0.001	3.4	0.0	0.0	0.021	100.0	0	01:13	24.12
CBMH05	0.001	3.3	0.0	0.0	0.024	83.8	0	01:22	9.26
CBMH06	0.001	3.8	0.0	0.0	0.024	98.6	0	01:22	9.69
CBMH07	0.000	1.1	0.0	0.0	0.012	40.4	0	01:21	8.30
CBMH08	0.000	1.4	0.0	0.0	0.015	46.9	0	01:21	9.06
CBMH09	0.000	3.2	0.0	0.0	0.003	66.2	0	01:22	20.49
CBMH10	0.000	1.5	0.0	0.0	0.001	49.0	0	01:21	6.37
CBMH11	0.000	4.6	0.0	0.0	0.004	70.1	0	01:23	18.99
CBMH12	0.000	2.2	0.0	0.0	0.002	52.8	0	01:24	15.49
Dummy02	0.000	0.9	0.0	0.0	0.000	4.9	0	01:57	40.26
EX_06_S	0.002	1.3	0.0	0.0	0.043	28.3	0	01:25	12.84
EX_15_S	0.006	3.0	0.0	0.0	0.123	65.1	0	01:26	35.34
EX_MH1	0.000	1.4	0.0	0.0	0.002	17.8	0	01:20	935.79
EX_MH2	0.000	1.5	0.0	0.0	0.002	20.5	0	01:20	953.73
EX_MH3	0.000	1.8	0.0	0.0	0.002	25.8	0	01:21	1107.28
EX-12_S	0.068	4.5	0.0	0.0	1.393	92.5	0	01:30	406.45
LCB01	0.000	6.2	0.0	0.0	0.000	52.8	0	01:35	1.55
LCB02	0.000	5.2	0.0	0.0	0.000	41.2	0	01:43	8.60
RY01	0.000	1.3	0.0	0.0	0.000	58.9	0	01:20	7.92
RY02	0.000	1.8	0.0	0.0	0.000	63.4	0	01:21	25.70
RY03	0.000	3.4	0.0	0.0	0.000	64.9	0	01:22	26.36
RY04	0.000	2.5	0.0	0.0	0.000	57.5	0	01:23	9.12
RY05	0.000	7.7	0.0	0.0	0.001	61.6	0	01:35	34.71
RY06	0.000	8.5	0.0	0.0	0.001	60.8	0	01:42	30.51
RY07	0.000	6.2	0.0	0.0	0.000	52.9	0	01:35	7.47
RY08	0.000	0.1	0.0	0.0	0.001	13.5	0	01:13	5.10
RY09	0.000	0.6	0.0	0.0	0.000	28.1	0	01:22	6.90
RY10	0.000	0.7	0.0	0.0	0.000	29.3	0	01:22	6.87
RY11	0.000	1.5	0.0	0.0	0.000	44.1	0	01:23	8.34
RY12	0.000	1.5	0.0	0.0	0.000	43.3	0	01:23	6.84
RY13	0.000	1.6	0.0	0.0	0.000	45.0	0	01:24	6.80
RY14	0.000	1.6	0.0	0.0	0.000	45.0	0	01:24	6.77

***** Summary
Outfall Loading Summary

Outfall Node	Flow Freq Pcnt	Avg Flow LPS	Max Flow LPS	Total Volume 10 ⁶ ltr
1950mm_STM	99.11	69.38	1107.28	5.941
OF1	0.00	0.00	0.00	0.000
OF2	12.39	5.12	78.68	0.055
OF3	94.43	0.52	2.19	0.042
OF4	4.72	14.27	69.95	0.058
OF5	2.39	89.94	333.43	0.186
OF6	0.00	0.00	0.00	0.000
OF7	0.00	0.00	0.00	0.000
OF8	0.00	0.00	0.00	0.000
SU5	16.97	10.42	77.60	0.153
Woodroffe_Ditch	12.53	6.92	80.40	0.075
System	22.05	196.57	1645.52	6.510

Link Flow Summary

Link	Type	Maximum Flow LPS	Time of Max Occurrence days hr:min	Maximum Veloc m/sec	Max/ Full Flow	Max/ Full Depth
201-202	CONDUIT	184.43	0 01:12	1.70	0.75	0.65
211-201	CONDUIT	152.46	0 01:12	1.30	0.64	0.69
212-211	CONDUIT	126.91	0 01:22	1.27	0.44	0.62
213-212	CONDUIT	78.53	0 01:18	0.95	0.50	0.51
214-Dummy	CONDUIT	43.37	0 01:23	0.75	0.38	0.52
215-212	CONDUIT	52.89	0 01:58	0.84	0.37	0.42
216-Dummy	CONDUIT	21.90	0 01:57	0.59	0.42	0.55
217-216	CONDUIT	7.10	0 02:15	0.55	0.12	0.25
C1	CONDUIT	6.24	0 01:34	0.77	0.06	0.17
C10	CONDUIT	0.00	0 00:00	0.00	0.00	0.08
C11	CONDUIT	18.36	0 01:12	0.08	0.00	0.09
C12	CONDUIT	0.00	0 00:00	0.00	0.00	0.11
C13	CONDUIT	0.00	0 00:00	0.00	0.00	0.09
C14	CONDUIT	0.00	0 00:00	0.00	0.00	0.08
C15	CONDUIT	0.00	0 00:00	0.00	0.00	0.08
C16	CONDUIT	0.00	0 00:00	0.00	0.00	0.11
C17	CONDUIT	0.00	0 00:00	0.00	0.00	0.08
C18	CONDUIT	0.00	0 00:00	0.00	0.00	0.08
C19	CHANNEL	0.00	0 00:00	0.00	0.00	0.01
C2	CONDUIT	7.72	0 01:35	0.78	0.08	0.20
C20	CONDUIT	0.00	0 00:00	0.00	0.00	0.03
C21	CONDUIT	0.00	0 00:00	0.00	0.00	0.14
C22	CONDUIT	6.42	0 01:43	0.77	0.07	0.18
C23	CONDUIT	14.01	0 01:13	0.04	0.00	0.11
C24	CONDUIT	11.04	0 01:13	0.05	0.00	0.07
C25	CONDUIT	0.00	0 00:00	0.00	0.00	0.10
C26	CONDUIT	0.00	0 00:00	0.00	0.00	0.09
C27	CONDUIT	0.00	0 00:00	0.00	0.00	0.10
C28	CONDUIT	0.00	0 00:00	0.00	0.00	0.12
C29	CONDUIT	0.00	0 00:00	0.00	0.00	0.10
C3	CONDUIT	10.12	0 01:13	1.32	0.13	0.26
C30	CONDUIT	0.00	0 00:00	0.00	0.00	0.12
C31	CONDUIT	0.00	0 00:00	0.00	0.00	0.14
C32	CONDUIT	0.00	0 00:00	0.00	0.00	0.14
C33	CONDUIT	0.00	0 00:00	0.00	0.00	0.08
C34	CHANNEL	14.42	0 01:10	0.23	0.00	0.04
C35	CHANNEL	28.08	0 01:10	0.60	0.00	0.05
C36	CHANNEL	10.71	0 01:11	0.39	0.00	0.04
C37	CHANNEL	53.70	0 01:10	1.49	0.00	0.05
C38	CONDUIT	0.00	0 00:00	0.00	0.00	0.13
C39	CONDUIT	0.00	0 00:00	0.00	0.00	0.12
C4	CONDUIT	7.30	0 01:31	0.77	0.07	0.19
C40	CONDUIT	0.00	0 00:00	0.00	0.00	0.12
C41	CONDUIT	0.00	0 00:00	0.00	0.00	0.09
C42	CONDUIT	0.00	0 00:00	0.00	0.00	0.08
C43	CONDUIT	0.00	0 00:00	0.00	0.00	0.05
C44	CONDUIT	2.19	0 01:23	0.58	0.00	0.12
C45	CONDUIT	24.12	0 01:06	0.51	0.41	1.00
C46	CONDUIT	0.00	0 00:00	0.00	0.00	0.09
C47	CONDUIT	0.00	0 00:00	0.00	0.00	0.02
C48	CONDUIT	0.00	0 00:00	0.00	0.00	0.02
C49	CONDUIT	0.00	0 00:00	0.00	0.00	0.08
C5	CHANNEL	34.31	0 01:10	0.96	0.00	0.03
C50	CONDUIT	7.41	0 01:04	0.63	0.11	1.00
C51	CONDUIT	0.00	0 00:00	0.00	0.00	0.12
C52	CONDUIT	0.00	0 00:00	0.00	0.00	0.04
C53	CONDUIT	0.00	0 00:00	0.00	0.00	0.12
C54	CONDUIT	14.87	0 01:05	0.47	0.22	1.00
C55	CONDUIT	6.90	0 01:08	0.65	0.12	1.00
C56	CONDUIT	6.87	0 01:08	0.65	0.12	1.00
C57	CONDUIT	15.49	0 01:04	0.54	0.23	1.00
C58	CONDUIT	6.77	0 01:06	0.65	0.11	1.00
C59	CONDUIT	0.00	0 00:00	0.00	0.00	0.09
C6	CONDUIT	22.36	0 01:12	0.07	0.00	0.11
C60	CONDUIT	0.00	0 00:00	0.00	0.00	0.10
C61	CONDUIT	6.80	0 01:05	0.65	0.11	1.00
C62	CONDUIT	8.34	0 01:07	0.61	0.03	1.00
C63	CONDUIT	6.84	0 01:06	0.65	0.11	1.00
C64	CONDUIT	77.60	0 01:12	1.80	0.75	0.82
C65	CONDUIT	184.49	0 01:12	1.53	0.54	0.54
C66	CONDUIT	203.53	0 01:13	1.69	0.55	0.54
C67	CONDUIT	216.36	0 01:13	1.45	0.59	0.52

**3400 Woodroffe Avenue (124147)
PCSWMM Model Output
100yr 3-hour Chicago Storm**

C68	CONDUIT	287.73	0	01:14	1.25	0.63	0.61
C69	CONDUIT	415.34	0	01:15	1.76	0.76	0.63
C7	CONDUIT	0.00	0	00:00	0.00	0.00	0.14
C70	CONDUIT	501.19	0	01:15	2.47	0.59	0.55
C71	CONDUIT	935.79	0	01:15	2.51	0.92	1.00
C72	CONDUIT	953.73	0	01:18	2.27	0.89	1.00
C73	CONDUIT	1107.28	0	01:21	2.52	1.10	0.92
C74	CHANNEL	28.69	0	01:10	0.59	0.00	0.05
C75	CHANNEL	11.27	0	01:10	0.42	0.00	0.04
C76	CHANNEL	29.18	0	01:10	0.78	0.00	0.05
C77	CHANNEL	41.67	0	01:10	0.61	0.00	0.06
C78	CHANNEL	78.68	0	01:10	0.76	0.00	0.08
C79	CHANNEL	71.17	0	01:10	0.75	0.00	0.07
C8	CONDUIT	0.00	0	00:00	0.00	0.00	0.09
C80	CHANNEL	47.04	0	01:11	0.58	0.00	0.06
C81	CHANNEL	107.28	0	01:11	0.52	0.00	0.08
C82	CHANNEL	180.17	0	01:11	0.70	0.00	0.09
C83	CHANNEL	241.73	0	01:11	0.82	0.00	0.09
C84	CHANNEL	259.78	0	01:11	0.85	0.00	0.10
C85	CHANNEL	265.96	0	01:12	0.97	0.00	0.09
C86	CHANNEL	293.38	0	01:12	1.01	0.00	0.09
C87	CHANNEL	333.43	0	01:12	0.90	0.00	0.10
C88	CONDUIT	0.00	0	00:00	0.00	0.00	0.15
C89	CONDUIT	0.00	0	00:00	0.00	0.00	0.11
C9	CONDUIT	0.00	0	00:00	0.00	0.00	0.09
C90	CONDUIT	0.00	0	00:00	0.00	0.00	0.00
C91	CONDUIT	0.00	0	00:00	0.00	0.00	0.00
C92	CHANNEL	0.00	0	00:00	0.00	0.00	0.05
CB01-Storage	CONDUIT	29.67	0	01:04	0.03	0.01	1.00
CB02-Storage	CONDUIT	30.11	0	01:07	0.09	0.01	1.00
CB03-Storage	CONDUIT	20.15	0	01:04	0.10	0.00	1.00
CB04-Storage	CONDUIT	15.62	0	01:04	0.01	0.00	1.00
CB05-Storage	CONDUIT	21.72	0	01:04	0.04	0.01	1.00
CB06-Storage	CONDUIT	14.90	0	01:04	0.01	0.00	1.00
CBMH03-214	CONDUIT	11.68	0	01:13	0.61	0.21	0.33
dummy-213	CONDUIT	61.76	0	01:23	0.94	0.56	0.58
dummy-215	CONDUIT	40.26	0	01:58	0.80	0.41	0.47
EX_STM-16 (EX_STM)	CONDUIT	38.80	0	01:12	1.71	0.37	0.47
RY01-RY02	CONDUIT	11.61	0	01:08	0.17	0.06	1.00
RY04-RY03	CONDUIT	13.84	0	01:09	0.31	0.07	1.00
RY05-CBMH02	CONDUIT	34.44	0	01:06	0.85	0.46	1.00
RY06-CB02	CONDUIT	30.51	0	01:07	0.79	0.51	1.00
ry07-ry05	CONDUIT	24.58	0	01:03	0.53	0.41	1.00
O-CB01	ORIFICE	6.24	0	01:42	1.00		
O-CB02	ORIFICE	6.42	0	01:42	1.00		
O-CB03	ORIFICE	7.30	0	01:31	1.00		
O-CB04	ORIFICE	7.52	0	01:24	1.00		
O-CB05	ORIFICE	6.24	0	01:33	1.00		
O-CB06	ORIFICE	6.07	0	01:26	1.00		
O-CBMH01	ORIFICE	9.16	0	01:19	1.00		
O-CBMH02	ORIFICE	7.72	0	01:34	1.00		
O-CBMH03	ORIFICE	11.68	0	01:12	1.00		
O-CBMH04	ORIFICE	10.11	0	01:13	1.00		
O-CBMH05	ORIFICE	9.26	0	01:22	1.00		
O-CBMH06	ORIFICE	9.69	0	01:22	1.00		
O-CBMH07	ORIFICE	8.30	0	01:21	1.00		
O-CBMH08	ORIFICE	9.06	0	01:21	1.00		
O-CBMH09	ORIFICE	7.15	0	01:22	1.00		
O-CBMH11	ORIFICE	7.61	0	01:23	1.00		
OR3	ORIFICE	406.45	0	01:30	1.00		
OR4	ORIFICE	12.84	0	01:25	1.00		
OR5	ORIFICE	35.34	0	01:26	1.00		
O-RY02	ORIFICE	16.81	0	01:21	1.00		
O-ry03	ORIFICE	16.47	0	01:22	1.00		
O-RY08	ORIFICE	5.10	0	01:13	1.00		
O-CB07	DUMMY	16.36	0	01:11			
O-CB08	DUMMY	19.40	0	01:06			
O-CB09/CB10	DUMMY	18.99	0	01:10			
OL1	DUMMY	19.40	0	01:06			
OL10	DUMMY	30.60	0	01:02			
OL11	DUMMY	73.50	0	01:02			
OL12	DUMMY	83.70	0	01:02			
OL2	DUMMY	19.40	0	01:05			
OL3	DUMMY	19.40	0	01:02			
OL4	DUMMY	16.83	0	01:10			
OL5	DUMMY	19.40	0	01:05			
OL6	DUMMY	71.50	0	01:02			
OL7	DUMMY	93.90	0	01:02			
OL8	DUMMY	85.80	0	01:02			
OL9	DUMMY	30.60	0	01:02			

Flow Classification Summary

Conduit	Adjusted /Actual Length	Fraction of Time in Flow Class						Norm Inlet		
		Dry	Up Dry	Down Dry	Sub Crit	Sup Crit	Up Crit			
201-202	1.00	0.01	0.00	0.00	0.00	0.00	0.00	0.99	0.00	0.00
211-201	1.00	0.01	0.00	0.00	0.00	0.00	0.00	0.99	0.00	0.00
212-211	1.00	0.01	0.00	0.00	0.00	0.07	0.15	0.00	0.77	0.22
213-212	1.00	0.01	0.00	0.00	0.00	0.00	0.00	0.99	0.00	0.00
214-Dummy	1.00	0.01	0.00	0.00	0.99	0.00	0.00	0.00	0.99	0.00
215-212	1.00	0.01	0.00	0.00	0.00	0.00	0.00	0.99	0.00	0.00
216-Dummy	1.00	0.01	0.00	0.00	0.99	0.00	0.00	0.00	0.95	0.00
217-216	1.00	0.01	0.00	0.00	0.06	0.00	0.00	0.93	0.03	0.00
C1	1.00	0.01	0.00	0.00	0.00	0.00	0.00	0.99	0.00	0.00
C10	1.00	0.97	0.03	0.00	0.00	0.00	0.00	0.00	0.00	0.00
C11	1.00	0.94	0.05	0.00	0.01	0.00	0.00	0.00	0.95	0.00
C12	1.00	0.95	0.05	0.00	0.00	0.00	0.00	0.00	0.00	0.00
C13	1.00	0.94	0.06	0.00	0.00	0.00	0.00	0.00	0.00	0.00
C14	1.00	0.97	0.03	0.00	0.00	0.00	0.00	0.00	0.00	0.00
C15	1.00	0.93	0.07	0.00	0.00	0.00	0.00	0.00	0.00	0.00
C16	1.00	0.90	0.10	0.00	0.00	0.00	0.00	0.00	0.00	0.00
C17	1.00	0.93	0.07	0.00	0.00	0.00	0.00	0.00	0.00	0.00
C18	1.00	0.93	0.07	0.00	0.00	0.00	0.00	0.00	0.00	0.00
C19	1.00	0.01	0.99	0.00	0.00	0.00	0.00	0.00	0.00	0.00
C2	1.00	0.01	0.00	0.00	0.00	0.00	0.00	0.99	0.00	0.00
C20	1.00	0.94	0.06	0.00	0.00	0.00	0.00	0.00	0.00	0.00
C21	1.00	0.88	0.12	0.00	0.00	0.00	0.00	0.00	0.00	0.00
C22	1.00	0.01	0.00	0.00	0.00	0.00	0.00	0.99	0.00	0.00
C23	1.00	0.96	0.03	0.00	0.01	0.00	0.00	0.00	0.94	0.00
C24	1.00	0.96	0.03	0.00	0.01	0.00	0.00	0.00	0.95	0.00
C25	1.00	0.92	0.08	0.00	0.00	0.00	0.00	0.00	0.00	0.00
C26	1.00	0.96	0.04	0.00	0.00	0.00	0.00	0.00	0.00	0.00
C27	1.00	0.96	0.04	0.00	0.00	0.00	0.00	0.00	0.00	0.00
C28	1.00	0.87	0.13	0.00	0.00	0.00	0.00	0.00	0.00	0.00
C29	1.00	0.96	0.04	0.00	0.00	0.00	0.00	0.00	0.00	0.00
C3	1.00	0.01	0.34	0.00	0.58	0.07	0.00	0.00	0.91	0.00
C30	1.00	0.87	0.13	0.00	0.00	0.00	0.00	0.00	0.00	0.00
C31	1.00	0.87	0.13	0.00	0.00	0.00	0.00	0.00	0.00	0.00
C32	1.00	0.87	0.13	0.00	0.00	0.00	0.00	0.00	0.00	0.00
C33	1.00	0.93	0.07	0.00	0.00	0.00	0.00	0.00	0.00	0.00
C34	1.00	0.77	0.03	0.00	0.20	0.00	0.00	0.00	0.98	0.00
C35	1.00	0.01	0.00	0.00	0.63	0.36	0.00	0.00	0.00	0.00
C36	1.00	0.71	0.02	0.00	0.28	0.00	0.00	0.00	0.98	0.00
C37	1.00	0.79	0.00	0.00	0.07	0.14	0.00	0.00	0.01	0.00
C38	1.00	0.95	0.05	0.00	0.00	0.00	0.00	0.00	0.00	0.00
C39	1.00	0.98	0.02	0.00	0.00	0.00	0.00	0.00	0.00	0.00
C4	1.00	0.01	0.00	0.00	0.00	0.00	0.00	0.99	0.00	0.00
C40	1.00	0.98	0.02	0.00	0.00	0.00	0.00	0.00	0.00	0.00
C41	1.00	0.98	0.02	0.00	0.00	0.00	0.00	0.00	0.00	0.00
C42	1.00	0.99	0.01	0.00	0.00	0.00	0.00	0.00	0.00	0.00
C43	1.00	0.92	0.08	0.00	0.00	0.00	0.00	0.00	0.00	0.00
C44	1.00	0.05	0.01	0.00	0.02	0.00	0.00	0.93	0.01	0.00
C45	1.00	0.04	0.00	0.00	0.16	0.00	0.00	0.80	0.01	0.00
C46	1.00	0.98	0.02	0.00	0.00	0.00	0.00	0.00	0.00	0.00
C47	1.00	1.00	0.00	0.00	0.00	0.00	0.00	0.00	0.00	0.00
C48	1.00	1.00	0.00	0.00	0.00	0.00	0.00	0.00	0.00	0.00
C49	1.00	0.97	0.03	0.00	0.00	0.00	0.00	0.00	0.00	0.00
C5	1.00	0.01	0.00	0.00	0.76	0.22	0.00	0.00	0.02	0.00
C50	1.00	0.04	0.00	0.00	0.14	0.00	0.00	0.82	0.00	0.00
C51	1.00	0.98	0.02	0.00	0.00	0.00	0.00	0.00	0.00	0.00
C52	1.00	0.91	0.09	0.00	0.00	0.00	0.00	0.00	0.00	0.00
C53	1.00	0.87	0.13	0.00	0.00	0.00	0.00	0.00	0.00	0.00
C54	1.00	0.01	0.00	0.00	0.06	0.00	0.00	0.94	0.01	0.00
C55	1.00	0.01	0.00	0.00	0.03	0.00	0.00	0.96	0.00	0.00
C56	1.00	0.01	0.00	0.00	0.03	0.00	0.00	0.96	0.00	0.00
C57	1.00	0.01	0.00	0.00	0.08	0.00	0.00	0.92	0.01	0.00
C58	1.00	0.01	0.00	0.00	0.06	0.00	0.00	0.94	0.00	0.00
C59	1.00	0.96	0.04	0.00	0.00	0.00	0.00	0.00	0.00	0.00
C6	1.00	0.96	0.03	0.00	0.01	0.00	0.00	0.00		

3400 Woodroffe Avenue (124147)
PCSWMM Model Output
100yr 3-hour Chicago Storm

C69	1.00	0.01	0.00	0.00	0.00	0.00	0.00	0.99	0.00	0.00
C7	1.00	0.88	0.12	0.00	0.00	0.00	0.00	0.00	0.00	0.00
C70	1.00	0.01	0.00	0.00	0.00	0.00	0.00	0.99	0.00	0.00
C71	1.00	0.01	0.00	0.00	0.01	0.00	0.00	0.98	0.00	0.00
C72	1.00	0.01	0.00	0.00	0.02	0.07	0.00	0.90	0.07	0.00
C73	1.00	0.01	0.00	0.00	0.00	0.00	0.00	0.99	0.00	0.00
C74	1.00	0.01	0.00	0.00	0.61	0.39	0.00	0.00	0.00	0.00
C75	1.00	0.69	0.01	0.00	0.23	0.08	0.00	0.00	0.12	0.00
C76	1.00	0.78	0.02	0.00	0.06	0.14	0.00	0.00	0.97	0.00
C77	1.00	0.76	0.05	0.00	0.07	0.13	0.00	0.00	0.99	0.00
C78	1.00	0.78	0.00	0.00	0.09	0.13	0.00	0.00	0.00	0.00
C79	1.00	0.01	0.00	0.00	0.36	0.63	0.00	0.00	0.00	0.00
C8	1.00	0.94	0.06	0.00	0.00	0.00	0.00	0.00	0.00	0.00
C80	1.00	0.52	0.01	0.00	0.34	0.14	0.00	0.00	0.01	0.00
C81	1.00	0.84	0.01	0.00	0.07	0.08	0.00	0.00	0.01	0.00
C82	1.00	0.84	0.01	0.00	0.07	0.08	0.00	0.00	0.02	0.00
C83	1.00	0.84	0.01	0.00	0.07	0.08	0.00	0.00	0.96	0.00
C84	1.00	0.85	0.01	0.00	0.06	0.08	0.00	0.00	0.95	0.00
C85	1.00	0.85	0.01	0.00	0.06	0.08	0.00	0.00	0.02	0.00
C86	1.00	0.85	0.01	0.00	0.06	0.08	0.00	0.00	0.04	0.00
C87	1.00	0.86	0.00	0.00	0.08	0.06	0.00	0.00	0.01	0.00
C88	1.00	0.97	0.03	0.00	0.00	0.00	0.00	0.00	0.00	0.00
C89	1.00	0.98	0.02	0.00	0.00	0.00	0.00	0.00	0.00	0.00
C9	1.00	0.94	0.06	0.00	0.00	0.00	0.00	0.00	0.00	0.00
C90	1.00	1.00	0.00	0.00	0.00	0.00	0.00	0.00	0.00	0.00
C91	1.00	1.00	0.00	0.00	0.00	0.00	0.00	0.00	0.00	0.00
C92	1.00	0.86	0.14	0.00	0.00	0.00	0.00	0.00	0.00	0.00
CB01-Storage	1.00	0.01	0.67	0.00	0.33	0.00	0.00	0.00	0.69	0.00
CB02-Storage	1.00	0.60	0.00	0.00	0.24	0.00	0.00	0.16	0.00	0.00
CB03-Storage	1.00	0.85	0.00	0.00	0.12	0.00	0.00	0.03	0.00	0.00
CB04-Storage	1.00	0.16	0.68	0.00	0.16	0.00	0.00	0.00	0.84	0.00
CB05-Storage	1.00	0.77	0.00	0.00	0.18	0.00	0.00	0.05	0.00	0.00
CB06-Storage	1.00	0.10	0.73	0.00	0.18	0.00	0.00	0.00	0.82	0.00
CBMH03-214	1.00	0.01	0.00	0.00	0.05	0.00	0.00	0.95	0.00	0.00
dummy-213	1.00	0.01	0.00	0.00	0.06	0.00	0.00	0.93	0.00	0.00
Dummy-215	1.00	0.01	0.00	0.00	0.16	0.00	0.00	0.83	0.00	0.00
EX_STM-16_(EX_STM)	1.00	0.01	0.00	0.00	0.00	0.02	0.00	0.97	0.02	0.00
RY01-RY02	1.00	0.03	0.01	0.00	0.04	0.00	0.00	0.91	0.01	0.00
RY04-RY03	1.00	0.03	0.01	0.00	0.05	0.00	0.00	0.91	0.01	0.00
RY05-CBMH02	1.00	0.01	0.00	0.00	0.15	0.00	0.00	0.84	0.00	0.00
RY06-CB02	1.00	0.01	0.00	0.00	0.18	0.00	0.00	0.81	0.01	0.00
ry07-ry05	1.00	0.02	0.02	0.00	0.14	0.00	0.00	0.81	0.01	0.00

Total elapsed time: 00:00:10

 Conduit Surcharge Summary

Conduit	Hours Full			Hours Above Full Normal Flow	Hours Capacity Limited
	Both Ends	Upstream	Dnstream		
C45	3.29	3.29	3.49	0.01	0.01
C50	3.10	3.10	3.11	0.01	0.01
C54	0.90	0.90	1.14	0.01	0.01
C55	0.57	0.57	0.58	0.01	0.01
C56	0.59	0.59	0.61	0.01	0.01
C57	1.31	1.31	1.64	0.01	0.01
C58	1.12	1.12	1.14	0.01	0.01
C61	1.12	1.12	1.14	0.01	0.01
C62	0.91	0.91	0.92	0.01	0.01
C63	1.08	1.08	1.10	0.01	0.01
C64	0.01	0.01	23.82	0.01	0.01
C71	0.12	0.12	0.14	0.01	0.01
C72	0.16	0.16	0.35	0.01	0.01
C73	0.01	0.37	0.01	0.26	0.01
CB01-Storage	3.61	3.61	3.62	0.01	0.01
CB02-Storage	3.59	3.59	3.61	0.01	0.01
CB03-Storage	2.19	2.19	2.20	0.01	0.01
CB04-Storage	1.66	1.66	1.67	0.01	0.01
CB05-Storage	2.60	2.60	2.61	0.01	0.01
CB06-Storage	1.88	1.88	1.89	0.01	0.01
RY01-RY02	0.54	0.54	0.64	0.01	0.01
RY04-RY03	0.71	0.71	0.83	0.01	0.01
RY05-CBMH02	3.36	3.36	3.50	0.01	0.01
RY06-CB02	3.87	3.87	4.03	0.01	0.01
ry07-ry05	3.07	3.07	3.32	0.01	0.01

Analysis begun on: Tue Apr 14 20:37:59 2026
 Analysis ended on: Tue Apr 14 20:38:09 2026

Overall Model Schematic - Site

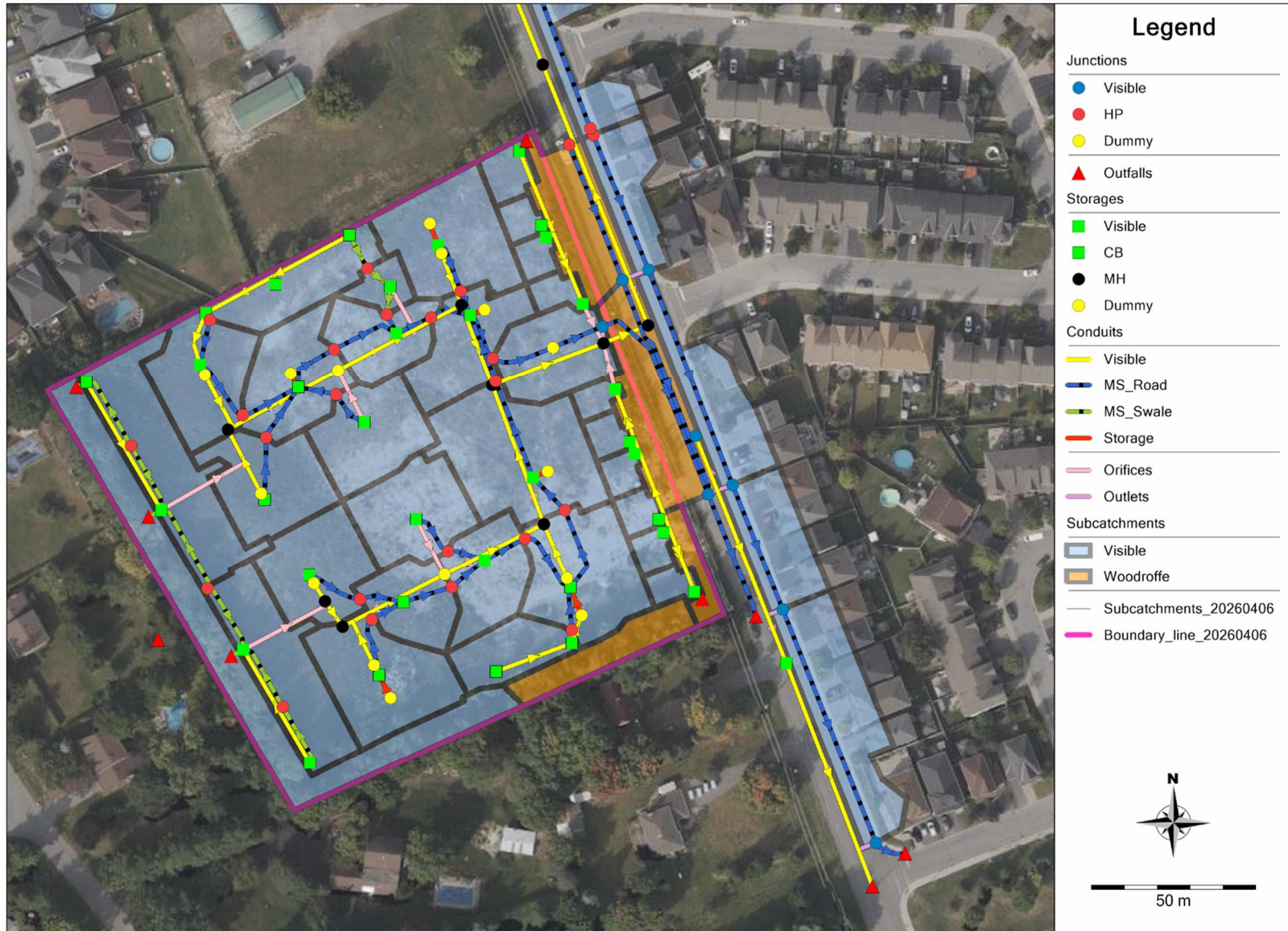

Overall Model Schematic – Offsite



Subcatchments (ID's)

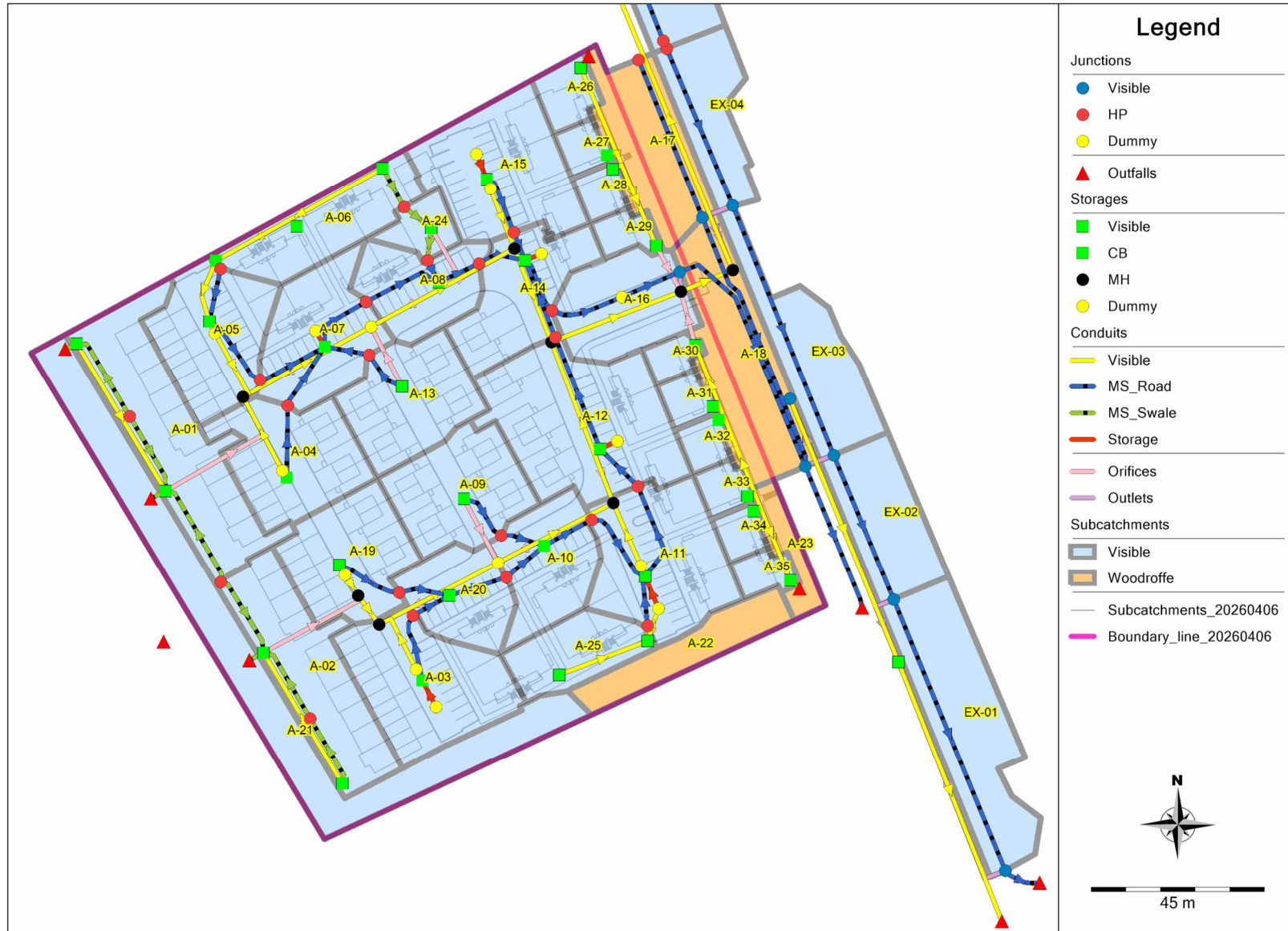

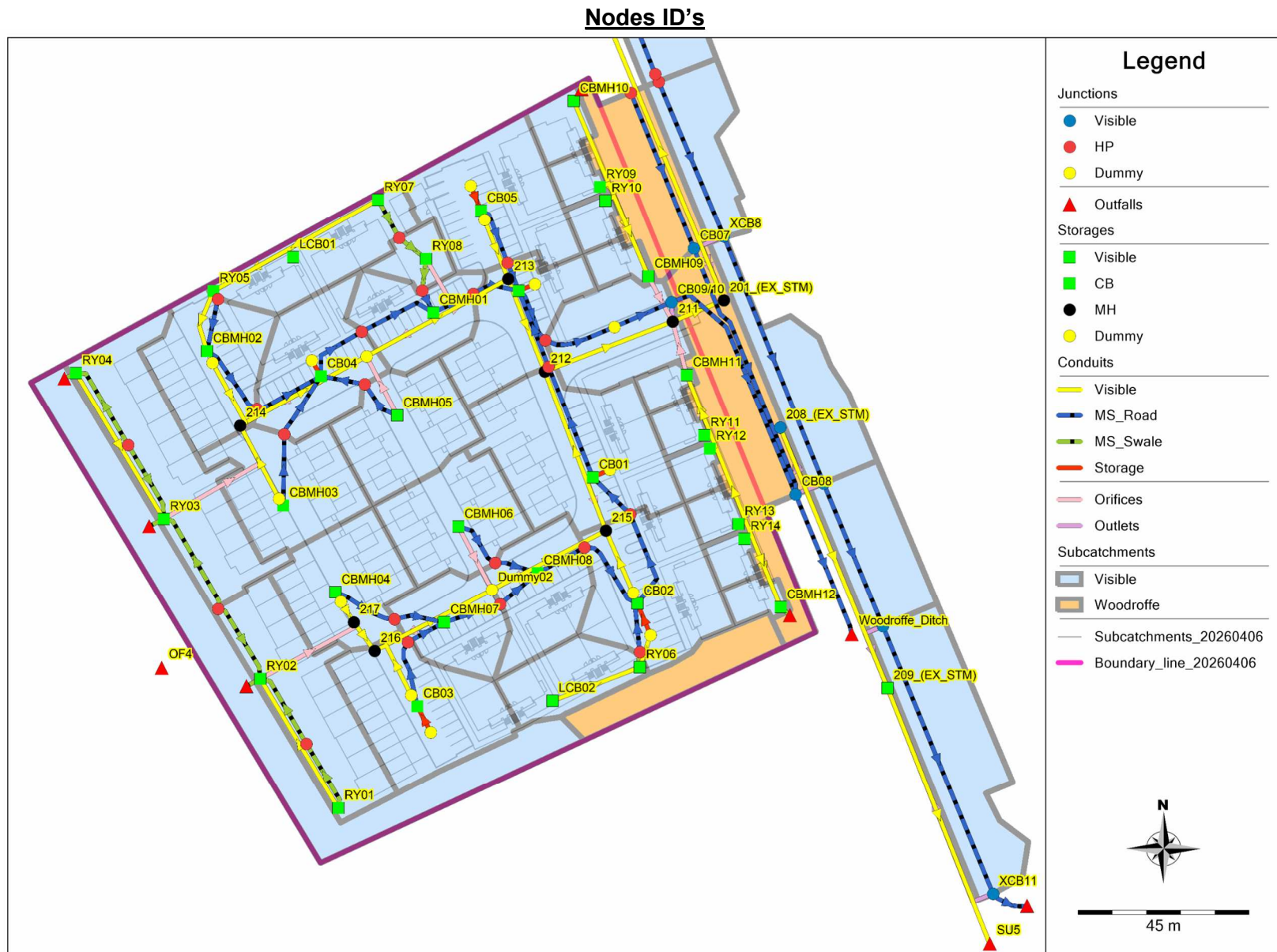

StormTech® SC-800 Chamber

Designed to meet the most stringent industry performance standards for superior structural integrity while providing designers with a cost-effective method to save valuable land and protect water resources. The StormTech system is designed primarily to be used under parking lots, thus maximizing land usage for private (commercial) and public applications. StormTech chambers can also be used in conjunction with Green Infrastructure, thus enhancing the performance and extending the service life of these practices.

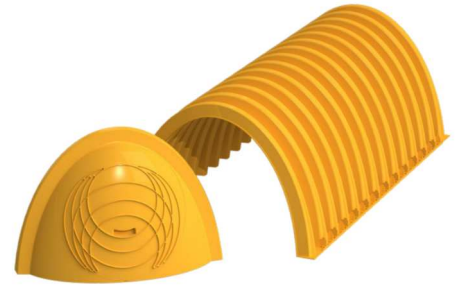

Nominal Chamber Specifications

(not to scale)

Size (L x W x H)
 85.4" x 51" x 33"
 2169 mm x 1295 mm x 838 mm

Chamber Storage
 50.6 ft³ (1.43 m³)

Min. Installed Storage*
 78.4 ft³ (2.22 m³)

Weight
 81.8 lbs (37.1 kg)

Shipping
 30 chambers/pallet
 60 end caps/pallet
 12 pallets/truck

*Assumes 6" (150 mm) stone above and below chambers, 3" (75 mm) stone between chambers, and 40% stone porosity.

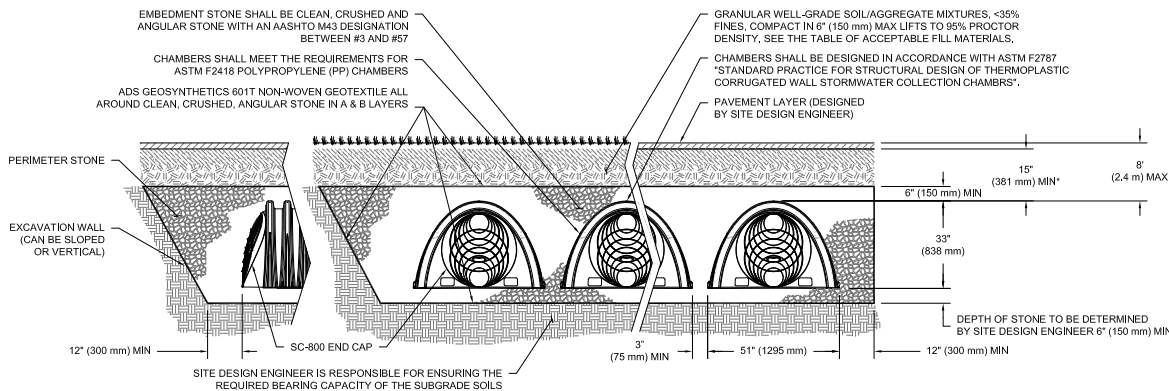
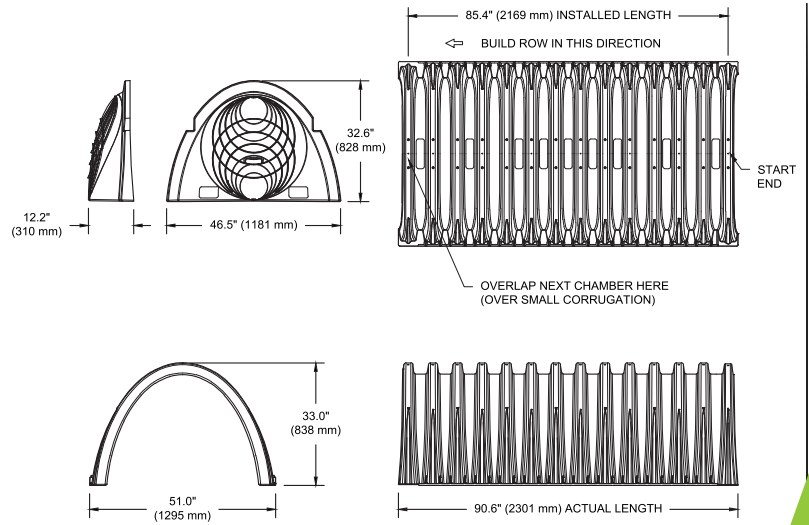

*MINIMUM COVER TO BOTTOM OF FLEXIBLE PAVEMENT, FOR UNPAVED INSTALLATIONS WHERE RUTTING FROM VEHICLES MAY OCCUR, INCREASE COVER TO 21" (533 mm).

StormTech SC-800 Specifications

Cumulative Storage Volumes Per Chamber

Assumes 40% Stone Porosity. Calculations are Based Upon a 6" (150 mm) Stone Base Under Chambers.

Depth of Water in System Inches (mm)	Cumulative Chamber Storage ft ³ (m ³)	Total System Cumulative Storage ft ³ (m ³)
45 (1143)	↑ 50.62 (1.433)	78.41 (2.22)
44 (1118)	50.62 (1.433)	77.34 (2.19)
43 (1092)	50.62 (1.433)	76.28 (2.16)
42 (1067)	Stone Cover ↑ 50.62 (1.433)	75.21 (2.13)
41 (1041)	50.62 (1.433)	74.14 (2.10)
40 (1016)	↓ 50.62 (1.433)	73.07 (2.07)
39 (991)	50.62 (1.433)	72.01 (2.04)
38 (965)	50.55 (1.431)	70.89 (2.01)
37 (940)	50.35 (1.426)	69.71 (1.97)
36 (914)	50.07 (1.418)	68.47 (1.94)
35 (889)	49.56 (1.403)	67.10 (1.90)
34 (864)	48.82 (1.382)	65.59 (1.86)
33 (838)	47.93 (1.357)	63.98 (1.81)
32 (813)	46.91 (1.328)	62.31 (1.76)
31 (787)	45.79 (1.297)	60.57 (1.72)
30 (762)	44.58 (1.262)	58.77 (1.66)
29 (737)	43.28 (1.226)	56.93 (1.61)
28 (711)	41.91 (1.187)	55.04 (1.56)
27 (686)	40.47 (1.146)	53.10 (1.50)
26 (660)	38.96 (1.103)	51.13 (1.45)
25 (635)	37.40 (1.059)	49.13 (1.39)
24 (610)	35.78 (1.013)	47.09 (1.33)
23 (584)	34.10 (0.966)	45.02 (1.27)
22 (559)	32.38 (0.917)	42.91 (1.22)
21 (533)	30.61 (0.867)	40.79 (1.15)
20 (508)	28.80 (0.816)	38.63 (1.09)
19 (483)	26.95 (0.763)	36.45 (1.03)
18 (457)	25.06 (0.710)	34.25 (0.97)
17 (432)	23.13 (0.655)	32.02 (0.91)
16 (406)	21.17 (0.599)	29.78 (0.84)
15 (381)	19.17 (0.543)	27.51 (0.78)
14 (356)	17.14 (0.485)	25.23 (0.71)
13 (330)	15.09 (0.427)	22.93 (0.65)
12 (305)	13.00 (0.368)	20.61 (0.58)
11 (279)	10.89 (0.308)	18.28 (0.52)
10 (254)	8.76 (0.248)	15.93 (0.45)
9 (229)	6.60 (0.187)	13.57 (0.38)
8 (203)	4.42 (0.125)	11.19 (0.32)
7 (178)	2.22 (0.063)	8.81 (0.25)
6 (152)	↑ 0 (0)	6.41 (0.18)
5 (127)	0 (0)	5.34 (0.15)
4 (102)	Stone Foundation ↑ 0 (0)	4.27 (0.12)
3 (76)	0 (0)	3.20 (0.09)
2 (51)	↓ 0 (0)	2.14 (0.06)
1 (25)	0 (0)	1.07 (0.03)

Note: Add 1.07 ft³ (0.03 m³) of storage for each additional inch (25 mm) of stone foundation.

ADS StormTech products, manufactured in accordance with ASTM F2418 or ASTM F2922, comply with all requirements in the Build America, Buy America (BABA) Act.

Working on a project?

Visit us at adspipe.com/stormtech and utilize the Design Tool

Storage Volume Per Chamber ft³ (m³)

	Bare Chamber Storage ft ³ (m ³)	Chamber and Stone Foundation Depth in. (mm)		
		6 (150)	12 (300)	18 (450)
SC-800 Chamber	50.6 (1.43)	78.4 (2.22)	84.8 (2.4)	91.2 (2.58)

Note: Assumes 6" (150 mm) stone above chambers, 3" (75 mm) row spacing and 40% stone porosity.

Amount of Stone Per Chamber

English Tons (yds ³)	Stone Foundation Depth		
	6"	12"	18"
SC-800	3.6 (2.6)	4.4 (3.2)	5.3 (3.8)
Metric Kilograms (m ³)	150 mm	300 mm	450 mm
SC-800	3270 (2.0)	3990 (2.4)	4810 (2.9)

Note: Assumes 6" (150 mm) of stone above chambers and 3" (75 mm) stone between chambers.

Volume Excavation Per Chamber yd³ (m³)

	Stone Foundation Depth		
	6" (150 mm)	12" (300 mm)	18" (450 mm)
SC-800	5.3 (4.1)	5.9 (4.5)	6.5 (5.0)

Note: Assumes 3" (75 mm) of row separation and 15" (375 mm) of cover. The volume of excavation will vary as depth of cover increases.



adspipe.com
800-821-6710

ACCEPTABLE FILL MATERIALS: STORMTECH SC-800 CHAMBER SYSTEMS

MATERIAL LOCATION		DESCRIPTION	AASHTO MATERIAL CLASSIFICATIONS	COMPACTION / DENSITY REQUIREMENT
D	FINAL FILL: FILL MATERIAL FOR LAYER 'D' STARTS FROM THE TOP OF THE 'C' LAYER TO THE BOTTOM OF FLEXIBLE PAVEMENT OR UNPAVED FINISHED GRADE ABOVE. NOTE THAT PAVEMENT SUBBASE MAY BE PART OF THE 'D' LAYER.	ANY SOIL/ROCK MATERIALS, NATIVE SOILS, OR PER ENGINEER'S PLANS. CHECK PLANS FOR PAVEMENT SUBGRADE REQUIREMENTS.	N/A	PREPARE PER SITE DESIGN ENGINEER'S PLANS. PAVED INSTALLATIONS MAY HAVE STRINGENT MATERIAL AND PREPARATION REQUIREMENTS.
C	INITIAL FILL: FILL MATERIAL FOR LAYER 'C' STARTS FROM THE TOP OF THE EMBEDMENT STONE ('B' LAYER) TO 375 mm (15") ABOVE THE TOP OF THE CHAMBER. NOTE THAT PAVEMENT SUBBASE MAY BE A PART OF THE 'C' LAYER.	GRANULAR WELL-GRADED SOIL/AGGREGATE MIXTURES, <35% FINES OR PROCESSED AGGREGATE. MOST PAVEMENT SUBBASE MATERIALS CAN BE USED IN LIEU OF THIS LAYER.	AASHTO M145 ¹ A-1, A-2-4, A-3 OR AASHTO M43 ¹ 3, 357, 4, 467, 5, 56, 57, 6, 67, 68, 7, 78, 8, 89, 9, 10	BEGIN COMPACTIONS AFTER 300 mm (12") OF MATERIAL OVER THE CHAMBERS IS REACHED. COMPACT ADDITIONAL LAYERS IN 150 mm (6") MAX LIFTS TO A MIN. 95% PROCTOR DENSITY FOR WELL GRADED MATERIAL AND 95% RELATIVE DENSITY FOR PROCESSED AGGREGATE MATERIALS. ROLLER GROSS VEHICLE WEIGHT NOT TO EXCEED 12,000 lbs (53 kN). DYNAMIC FORCE NOT TO EXCEED 20,000 lbs (89 kN).
B	EMBEDMENT STONE: FILL SURROUNDING THE CHAMBERS FROM THE FOUNDATION STONE ('A' LAYER) TO THE 'C' LAYER ABOVE.	CLEAN, CRUSHED, ANGULAR STONE OR RECYCLED CONCRETE ⁵	AASHTO M43 ¹ 3, 357, 4, 467, 5, 56, 57	NO COMPACTION REQUIRED.
A	FOUNDATION STONE: FILL BELOW CHAMBERS FROM THE SUBGRADE UP TO THE FOOT (BOTTOM) OF THE CHAMBER.	CLEAN, CRUSHED, ANGULAR STONE OR RECYCLED CONCRETE ⁵	AASHTO M43 ¹ 3, 357, 4, 467, 5, 56, 57	PLATE COMPACT OR ROLL TO ACHIEVE A FLAT SURFACE. ^{2,3}

PLEASE NOTE:

- THE LISTED AASHTO DESIGNATIONS ARE FOR GRADATIONS ONLY. THE STONE MUST ALSO BE CLEAN, CRUSHED, ANGULAR. FOR EXAMPLE, A SPECIFICATION FOR #4 STONE WOULD STATE: "CLEAN, CRUSHED, ANGULAR NO. 4 (AASHTO M43) STONE".
- STORMTECH COMPACTION REQUIREMENTS ARE MET FOR 'A' LOCATION MATERIALS WHEN PLACED AND COMPACTED IN 150 mm (6") (MAX) LIFTS USING TWO FULL COVERAGES WITH A VIBRATORY COMPACTOR.
- WHERE INFILTRATION SURFACES MAY BE COMPROMISED BY COMPACTION, FOR STANDARD DESIGN LOAD CONDITIONS, A FLAT SURFACE MAY BE ACHIEVED BY RAKING OR DRAGGING WITHOUT COMPACTION EQUIPMENT. FOR SPECIAL LOAD DESIGNS, CONTACT STORMTECH FOR COMPACTION REQUIREMENTS.
- ONCE LAYER 'C' IS PLACED, ANY SOIL/MATERIAL CAN BE PLACED IN LAYER 'D' UP TO THE FINISHED GRADE. MOST PAVEMENT SUBBASE SOILS CAN BE USED TO REPLACE THE MATERIAL REQUIREMENTS OF LAYER 'C' OR 'D' AT THE SITE DESIGN ENGINEER'S DISCRETION.
- WHERE RECYCLED CONCRETE AGGREGATE IS USED IN LAYERS 'A' OR 'B' THE MATERIAL SHOULD ALSO MEET THE ACCEPTABILITY CRITERIA OUTLINED IN TECHNICAL NOTE 6.20 "RECYCLED CONCRETE STRUCTURAL BACKFILL".

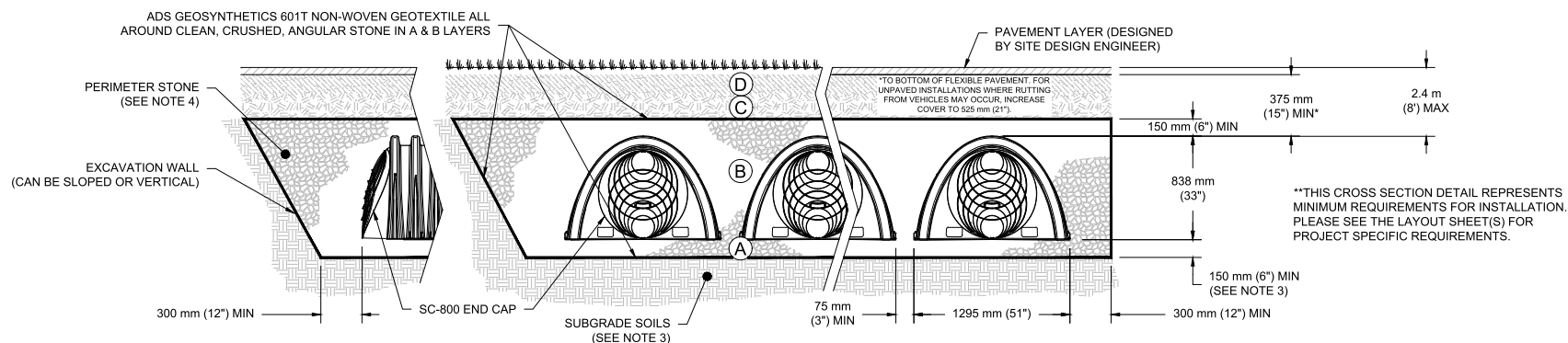

NOTES:

- CHAMBERS SHALL MEET THE REQUIREMENTS OF ASTM F2418, "STANDARD SPECIFICATION FOR POLYPROPYLENE (PP) CORRUGATED WALL STORMWATER COLLECTION CHAMBERS".
- SC-800 CHAMBERS SHALL BE DESIGNED IN ACCORDANCE WITH ASTM F2787 "STANDARD PRACTICE FOR STRUCTURAL DESIGN OF THERMOPLASTIC CORRUGATED WALL STORMWATER COLLECTION CHAMBERS".
- THE SITE DESIGN ENGINEER IS RESPONSIBLE FOR ASSESSING THE BEARING RESISTANCE (ALLOWABLE BEARING CAPACITY) OF THE SUBGRADE SOILS AND THE DEPTH OF FOUNDATION STONE WITH CONSIDERATION FOR THE RANGE OF EXPECTED SOIL MOISTURE CONDITIONS. REFERENCE STORMTECH DESIGN MANUAL FOR BEARING CAPACITY GUIDANCE.
- PERIMETER STONE MUST BE EXTENDED HORIZONTALLY TO THE EXCAVATION WALL FOR BOTH VERTICAL AND SLOPED EXCAVATION WALLS.
- REQUIREMENTS FOR HANDLING AND INSTALLATION:
 - TO MAINTAIN THE WIDTH OF CHAMBERS DURING SHIPPING AND HANDLING, CHAMBERS SHALL HAVE INTEGRAL, INTERLOCKING STACKING LUGS.
 - TO ENSURE A SECURE JOINT DURING INSTALLATION AND BACKFILL, THE HEIGHT OF THE CHAMBER JOINT SHALL NOT BE LESS THAN 50 mm (2").
 - TO ENSURE THE INTEGRITY OF THE ARCH SHAPE DURING INSTALLATION, a) THE ARCH STIFFNESS CONSTANT AS DEFINED IN SECTION 6.2.8 OF ASTM F2418 SHALL BE GREATER THAN OR EQUAL TO 700 LBS/FT². AND b) TO RESIST CHAMBER DEFORMATION DURING INSTALLATION AT ELEVATED TEMPERATURES (ABOVE 73° F / 23° C), CHAMBERS SHALL BE PRODUCED FROM REFLECTIVE GOLD OR YELLOW COLORS.

STANDARD CROSS SECTION SC-800 CHAMBER	DRAWING #: 0804/2025 DATE: 08/04/2025	DRAWN: SMW CHECKED: JLM
StormTech® Chamber System	DATE: 08/04/2025	DESCRIP TO: SC-800 CHAMBER
4640 TRUEMAN BLVD HILLIARD, OH 43026	THIS DRAWING HAS BEEN PREPARED BASED ON INFORMATION PROVIDED TO ADS/STORMTECH UNDER THE DIRECTION OF THE PROJECT'S ENGINEER OF RECORD (EOR) OR OTHER PROJECT REPRESENTATIVE. THE DRAWING IS NOT INTENDED FOR USE IN BIDDING OR CONSTRUCTION WITHOUT THE EOR'S PRIOR APPROVAL. EOR SHALL REVIEW THIS DRAWING PRIOR TO BIDDING AND/OR CONSTRUCTION. IT IS THE ULTIMATE RESPONSIBILITY OF THE EOR TO ENSURE THAT THE PRODUCT(S) SPECIFIED AND ALL ASSOCIATED DETAILS MEET ALL APPLICABLE LAWS, REGULATIONS AND PROJECT REQUIREMENTS.	
ADS	1 SHEET OF 1	

SC-800 TECHNICAL SPECIFICATION

NTS

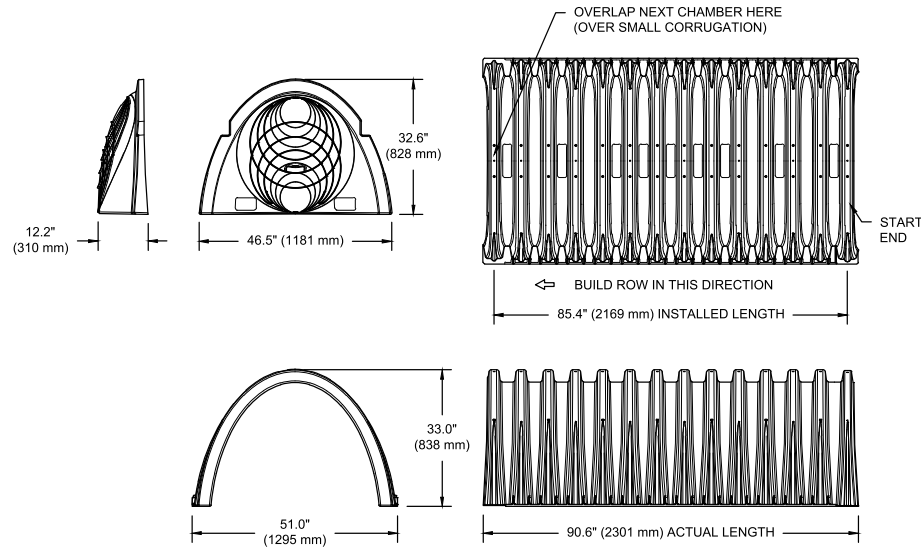

NOMINAL CHAMBER SPECIFICATIONS

SIZE (W X H X INSTALLED LENGTH)	51.0" X 33.0" X 85.4"	(1295 mm X 838 mm X 2169 mm)
CHAMBER STORAGE	50.6 CUBIC FEET	(1.43 m ³)
MINIMUM INSTALLED STORAGE*	78.4 CUBIC FEET	(2.22 m ³)
WEIGHT	81.8 lbs.	(37.1 kg)

NOMINAL END CAP SPECIFICATIONS

SIZE (W X H X INSTALLED LENGTH)	46.5" X 32.6" X 10.5"	(1181 mm X 828 mm X 267 mm)
END CAP STORAGE	3.4 CUBIC FEET	(0.09 m ³)
MINIMUM INSTALLED STORAGE**	14.7 CUBIC FEET	(0.42 m ³)
WEIGHT	15.7 lbs.	(7.1 kg)

* ASSUMES 6" (150 mm) STONE ABOVE AND BELOW CHAMBER, 3" (75 mm) BETWEEN CHAMBERS

**ASSUMES 6" (150 mm) STONE ABOVE AND BELOW END CAPS, 3" (75 mm) BETWEEN ROWS, 12" (300 mm) BEYOND END CAPS

PRE-CORED HOLES AT BOTTOM OF END CAP FOR PART NUMBERS ENDING WITH "BPC"
PRE-CORED HOLES AT TOP OF END CAP FOR PART NUMBERS ENDING WITH "TPC"

PART #	STUB	B	C
SC800EPE06TPC		21.4" (544 mm)	---
SC800EPE06BPC	6" (150 mm)	---	0.9" (23 mm)
SC800EPE08TPC		19.2" (488 mm)	---
SC800EPE08BPC	8" (200 mm)	---	1.0" (25 mm)
SC800EPE10TPC		17.0" (432 mm)	---
SC800EPE10BPC	10" (250 mm)	---	1.2" (30 mm)
SC800EPE12TPC		14.4" (366 mm)	---
SC800EPE12BPC	12" (300 mm)	---	1.6" (41 mm)
SC800EPE15TPC		11.3" (287 mm)	---
SC800EPE15BPC	15" (375 mm)	---	1.7" (43 mm)
SC800EPE18TPC		8.0" (203 mm)	---
SC800EPE18BPC	18" (450 mm)	---	2.0" (51 mm)
SC800ECEZ	24" (600 mm)	---	2.3" (58 mm)

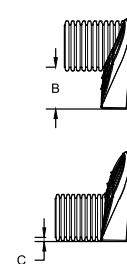

NOTE: ALL DIMENSIONS ARE NOMINAL

TECHNICAL SPECIFICATIONS
SC-800 CHAMBER

DATE: 04/18/2025 DRAWN: SWW CHECKED: JLM
DRAWING #: 721-810

DATE	DRAWN	CHKD	DESCRIPTION

StormTech®
Chamber System

4640 TRUEMAN BLVD
HILLIARD, OH 43026



THIS DRAWING HAS BEEN PREPARED BASED ON INFORMATION PROVIDED TO ASSIST STORMTECH UNDER THE DIRECTION OF THE PROJECT'S ENGINEER OF RECORD (EOR) OR OTHER PROJECT REPRESENTATIVE. THE DRAWING IS NOT INTENDED FOR USE IN BIDDING OR CONSTRUCTION WITHOUT THE EOR'S PRIOR APPROVAL. EOR SHALL REVIEW THIS DRAWING PRIOR TO BIDDING AND/OR CONSTRUCTION. IT IS THE ULTIMATE RESPONSIBILITY OF THE EOR TO ENSURE THAT THE PRODUCT(S) DEPICTED AND ALL ASSOCIATED DETAILS MEET ALL APPLICABLE LAWS, REGULATIONS, AND PROJECT REQUIREMENTS.

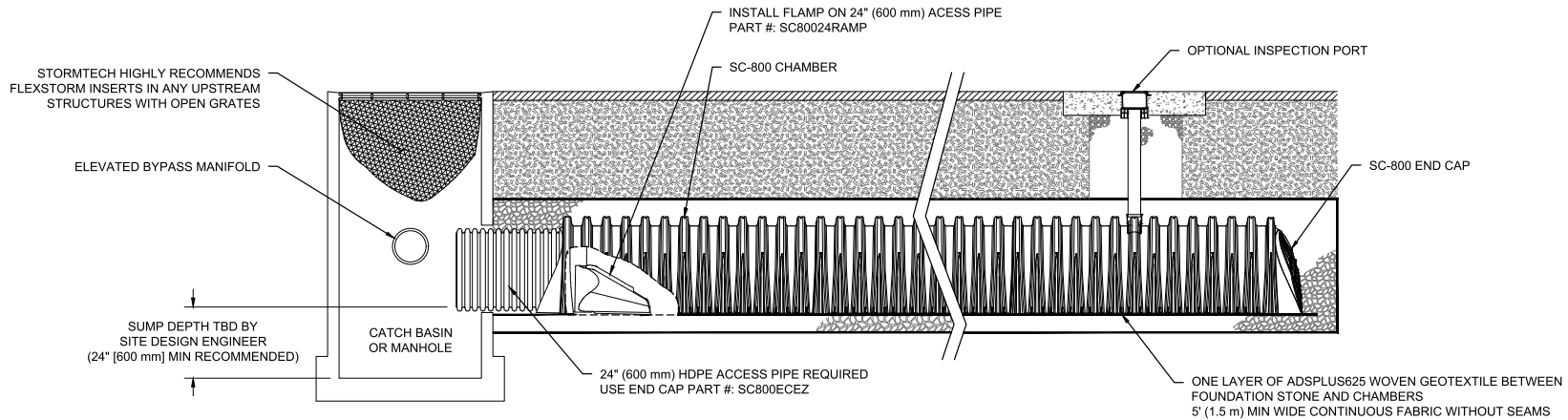

SC-800 ISOLATOR ROW PLUS DETAIL
NTS

INSPECTION & MAINTENANCE

- STEP 1) INSPECT ISOLATOR ROW PLUS FOR SEDIMENT
- A. INSPECTION PORTS (IF PRESENT)
 - A.1. REMOVE/OPEN LID ON NYLOPLAST INLINE DRAIN
 - A.2. REMOVE AND CLEAN FLEXSTORM FILTER IF INSTALLED
 - A.3. USING A FLASHLIGHT AND STADIA ROD, MEASURE DEPTH OF SEDIMENT AND RECORD ON MAINTENANCE LOG
 - A.4. LOWER A CAMERA INTO ISOLATOR ROW PLUS FOR VISUAL INSPECTION OF SEDIMENT LEVELS (OPTIONAL)
 - A.5. IF SEDIMENT IS AT, OR ABOVE, 3" (80 mm) PROCEED TO STEP 2. IF NOT, PROCEED TO STEP 3.
 - B. ALL ISOLATOR ROW PLUS
 - B.1. REMOVE COVER FROM STRUCTURE AT UPSTREAM END OF ISOLATOR ROW PLUS
 - B.2. USING A FLASHLIGHT, INSPECT DOWN THE ISOLATOR ROW PLUS THROUGH OUTLET PIPE
 - i) MIRRORS ON POLES OR CAMERAS MAY BE USED TO AVOID A CONFINED SPACE ENTRY
 - ii) FOLLOW OSHA REGULATIONS FOR CONFINED SPACE ENTRY IF ENTERING MANHOLE
 - B.3. IF SEDIMENT IS AT, OR ABOVE, 3" (80 mm) PROCEED TO STEP 2. IF NOT, PROCEED TO STEP 3.
- STEP 2) CLEAN OUT ISOLATOR ROW PLUS USING THE JETVAC PROCESS
- A. A FIXED CULVERT CLEANING NOZZLE WITH REAR FACING SPREAD OF 45° (1.1 m) OR MORE IS PREFERRED
 - B. APPLY MULTIPLE PASSES OF JETVAC UNTIL BACKFLUSH WATER IS CLEAN
 - C. VACUUM STRUCTURE SUMP AS REQUIRED
- STEP 3) REPLACE ALL COVERS, GRATES, FILTERS, AND LIDS; RECORD OBSERVATIONS AND ACTIONS.
- STEP 4) INSPECT AND CLEAN BASINS AND MANHOLES UPSTREAM OF THE STORMTECH SYSTEM.

NOTES

1. INSPECT EVERY 6 MONTHS DURING THE FIRST YEAR OF OPERATION. ADJUST THE INSPECTION INTERVAL BASED ON PREVIOUS OBSERVATIONS OF SEDIMENT ACCUMULATION AND HIGH WATER ELEVATIONS.
2. CONDUCT JETTING AND VACTORING ANNUALLY OR WHEN INSPECTION SHOWS THAT MAINTENANCE IS NECESSARY.

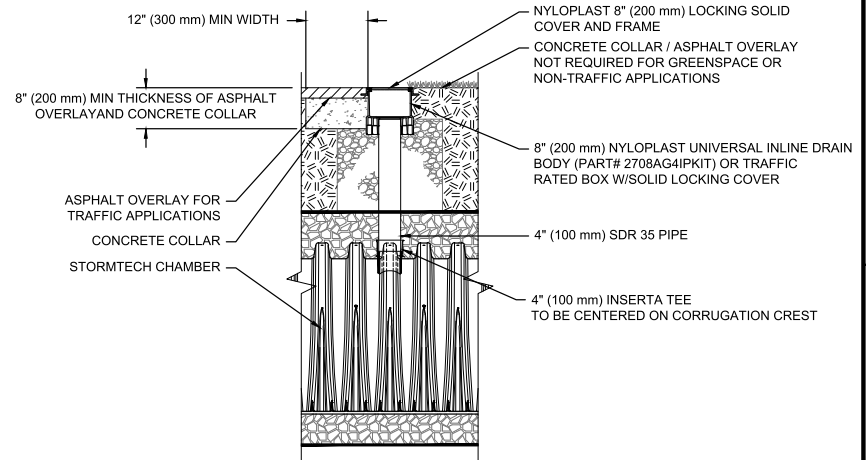

NOTE:
INSPECTION PORTS MAY BE CONNECTED THROUGH ANY CHAMBER CORRUGATION CREST.

4" PVC INSPECTION PORT DETAIL
(SC SERIES CHAMBER)
NTS

<p>StormTech® Chamber System</p>	<p>4640 TRUEMAN BLVD HILLIARD, OH 43026</p>
<p>ADS</p>	<p>THIS DRAWING HAS BEEN PREPARED BASED ON INFORMATION PROVIDED TO ADS/STORMTECH UNDER THE DIRECTION OF THE PROJECT'S ENGINEER OF RECORD (EOR) OR OTHER PROJECT REPRESENTATIVE. THE DRAWINGS ARE NOT INTENDED FOR USE IN BIDDING OR CONSTRUCTION WITHOUT THE EOR'S PRIOR APPROVAL. EOR SHALL REVIEW THIS DRAWING PRIOR TO BIDDING AND/OR CONSTRUCTION. IT IS THE ULTIMATE RESPONSIBILITY OF THE EOR TO ENSURE THAT THE PRODUCTS SPECIFIED AND ALL ASSOCIATED DETAILS MEET ALL APPLICABLE LAWS, REGULATIONS, AND PROJECT REQUIREMENTS.</p>
<p>ISOLATOR ROW PLUS SC-800 CHAMBER</p>	<p>DATE: 04/18/2025 DRAWN: SWW CHECKED: JLM DRAWING #: 721-830</p>
<p>1 SHEET OF 1</p>	<p>DESCRIPTION</p>

Isolator[®] Row Plus

O&M Manual



The Isolator[®] Row Plus

Introduction

An important component of any Stormwater Pollution Prevention Plan is inspection and maintenance. The StormTech Isolator Row Plus is a technique to inexpensively enhance Total Suspended Solids (TSS), Total Phosphorus (TP), Total Petroleum Hydrocarbons (TPH) and Total Nitrogen (TN) removal with easy access for inspection and maintenance.

The Isolator Row Plus

The Isolator Row Plus is a row of StormTech chambers, either SC-160, SC-310, DC-780, SC-800, MC-3500, MC-4500 or MC-7200 models, are lined with filter fabric and connected to a closely located manhole for easy access. The fabric lined chambers provide for sediment settling and filtration as stormwater rises in the Isolator Row Plus and passes through the filter fabric. The open bottom chambers allow stormwater to flow vertically out of the chambers. Sediments are captured in the Isolator Row Plus protecting the adjacent stone and chambers storage areas from sediment accumulation.

ADS Isolator Row and Plus fabric are placed between the stone and the Isolator Row Plus chambers. The woven geotextile provides a media for stormwater filtration, a durable surface for maintenance, prevents scour of the underlying stone and remains intact during high pressure jetting.

The Isolator Row Plus is designed to capture the “first flush” runoff and offers the versatility to be sized on a volume basis or a flow-rate basis. An upstream manhole provides access to the Isolator Row Plus and includes a high/low concept such that stormwater flow rates or volumes that exceed the capacity of the Isolator Row Plus bypass through a manifold to the other chambers. This is achieved with an elevated bypass manifold or a high-flow weir. This creates a differential between the Isolator Row Plus row of chambers and the manifold to the rest of the system, thus allowing for settlement time in the Isolator Row Plus. After Stormwater flows through the Isolator Row Plus and into the rest of the chamber system it is either exfiltrated into the soils below or passed at a controlled rate through an outlet manifold and outlet control structure.

The Isolator Row Plus Flamp™ is a flared end ramp apparatus attached to the inlet pipe on the inside of the chamber end cap. The FLAMP provides a smooth transition from pipe invert to fabric bottom. It is configured to improve chamber function performance by enhancing outflow of solid debris that would otherwise collect at the chamber's end, or more difficult to remove and require confined space entry into the chamber area. It also serves to improve the fluid and solid flow into the access pipe during maintenance and cleaning and to guide cleaning and inspection equipment back into the inlet pipe when complete.

The Isolator Row Plus may be part of a treatment train system. The treatment train design and pretreatment device selection by the design engineer is often driven by regulatory requirements. Whether pretreatment is used or not, StormTech recommend using the Isolator Row Plus to minimize maintenance requirements and maintenance costs.

Note: See the StormTech Design Manual for detailed information on designing inlets for a StormTech system, including the Isolator Row Plus.



Looking down the Isolator Row Plus from the manhole opening, ADS Plus Fabric is shown between the chamber and stone base.



StormTech Isolator Row Plus with Overflow Structure (not to scale)

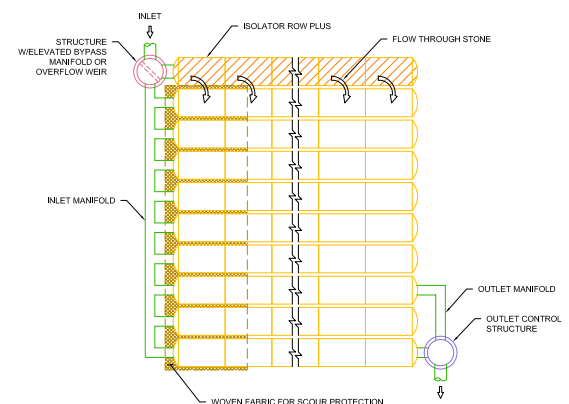

Isolator Row Plus Inspection/Maintenance

Inspection

The frequency of inspection and maintenance varies by location. A routine inspection schedule needs to be established for each individual location based upon site specific variables. The type of land use (i.e. industrial, commercial, residential), anticipated pollutant load, percent imperviousness, climate, etc. all play a critical role in determining the actual frequency of inspection and maintenance practices.

At a minimum, StormTech recommends annual inspections. Initially, the Isolator Row Plus should be inspected every 6 months for the first year of operation. For subsequent years, the inspection should be adjusted based upon previous observation of sediment deposition.

The Isolator Row Plus incorporates a combination of standard manhole(s) and strategically located inspection ports (as needed). The inspection ports allow for easy access to the system from the surface, eliminating the need to perform a confined space entry for inspection purposes.

If upon visual inspection it is found that sediment has accumulated, a stadia rod should be inserted to determine the depth of sediment. When the average depth of sediment exceeds 3" (75 mm) throughout the length of the Isolator Row Plus, clean-out should be performed.

Maintenance

The Isolator Row Plus was designed to reduce the cost of periodic maintenance. By "isolating" sediments to just one row, costs are dramatically reduced by eliminating the need to clean out each row of the entire storage bed. If inspection indicates the potential need for maintenance, access is provided

via a manhole(s) located on the end(s) of the row for cleanout. If entry into the manhole is required, please follow local and OSHA rules for a confined space entry.

Maintenance is accomplished with the JetVac process. The JetVac process utilizes a high pressure water nozzle to propel itself down the Isolator Row Plus while scouring and suspending sediments. As the nozzle is retrieved, the captured pollutants are flushed back into the manhole for vacuuming. Most sewer and pipe maintenance companies have vacuum/JetVac combination vehicles. Selection of an appropriate JetVac nozzle will improve maintenance efficiency. Fixed nozzles designed for culverts or large diameter pipe cleaning are preferable. Rear facing jets with an effective spread of at least 45" are best. StormTech recommends a maximum nozzle pressure of 2000 psi be utilized during cleaning. JetVac reels can vary in length. For ease of maintenance, ADS recommends Isolator Row Plus lengths up to 200' (61 m). **The JetVac process shall only be performed on StormTech Isolator Row Plus that have ADS Plus Fabric (as specified by StormTech) over their angular base stone.**

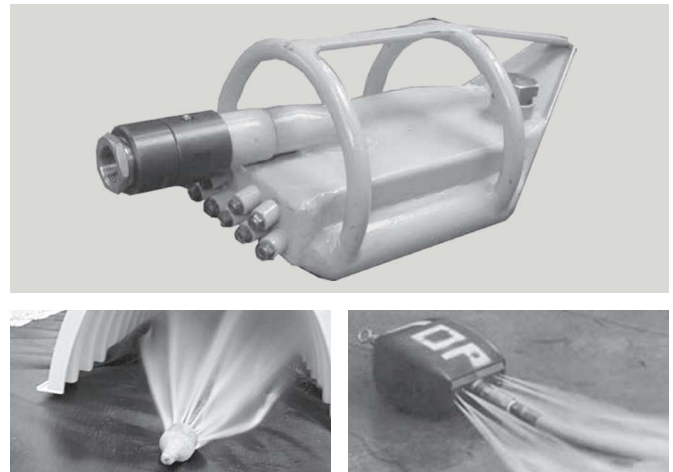

StormTech Isolator Row Plus (not to scale)

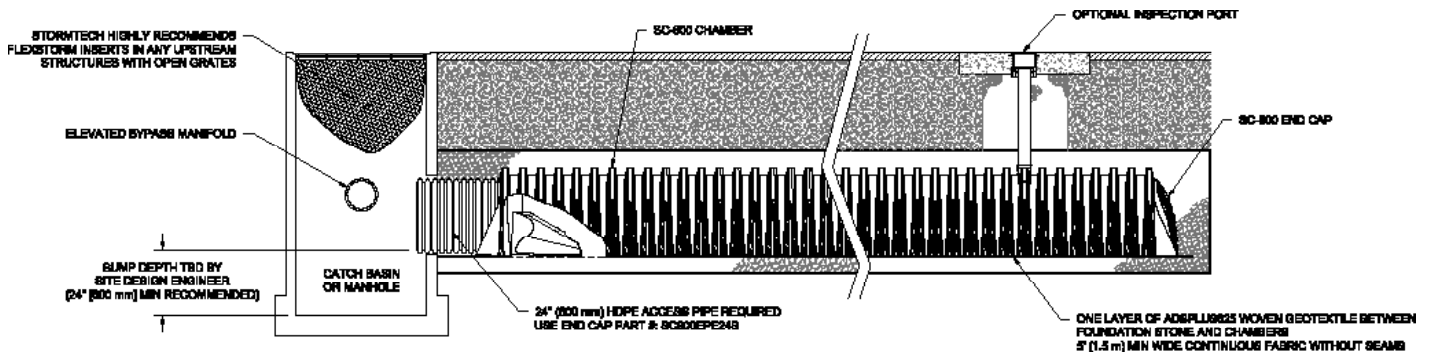

Isolator Row Plus Step By Step Maintenance Procedures

Step 1

Inspect Isolator Row Plus for sediment.

- A) Inspection ports (if present)
 - i. Remove lid from floor box frame
 - ii. Remove cap from inspection riser
 - iii. Using a flashlight and stadia rod, measure depth of sediment and record results on maintenance log.
 - iv. If sediment is at or above 3 inch depth, proceed to Step 2. If not, proceed to Step 3.
- B) All Isolator Row Plus
 - i. Remove cover from manhole at upstream end of Isolator Row Plus
 - ii. Using a flashlight, inspect down Isolator Row Plus through outlet pipe
 - 1. Mirrors on poles or cameras may be used to avoid a confined space entry
 - 2. Follow OSHA regulations for confined space entry if entering manhole
 - iii. If sediment is at or above the lower row of sidewall holes (approximately 3 inches), proceed to Step 2. If not, proceed to Step 3.

Step 2

Clean out Isolator Row Plus using the JetVac process.

- A) A fixed floor cleaning nozzle with rear facing nozzle spread of 45 inches or more is preferable
- B) Apply multiple passes of JetVac until backflush water is clean
- C) Vacuum manhole sump as required

Step 3

Replace all caps, lids and covers, record observations and actions.

Step 4

Inspect & clean catch basins and manholes upstream of the StormTech system.

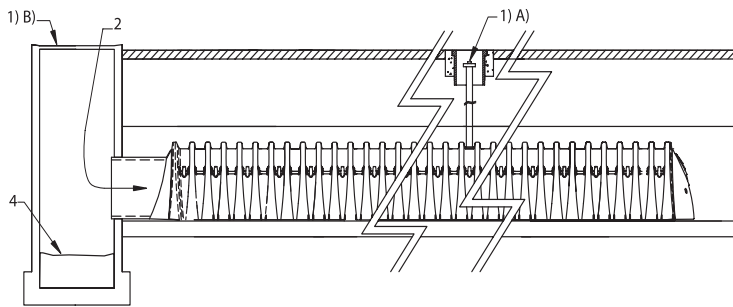

Sample Maintenance Log

Date	Stadia Rod Readings		Sedi-ment Depth (1)-(2)	Observations/Actions	Inspector
	Fixed point to chamber bottom (1)	Fixed point to top of sediment (2)			
3/15/11	6.3 ft	none		New installation. Fixed point is CI frame at grade	DJM
9/24/11		6.2	0.1 ft	Some grit felt	SM
6/20/13		5.8	0.5 ft	Mucky feel, debris visible in manhole and in Isolator Row Plus, maintenance due	NV
7/7/13	6.3 ft		0	System jettted and vacuumed	DJM

adspipe.com

800-821-6710

StormTech® Installation Guide

SC-310/DC-780/SC-800



StormTech
Installation Video

Required Materials and Equipment List

- Acceptable fill materials per Table 1
- ADS Plus and non-woven geotextile fabrics
- StormTech solid end caps and pre-cored end caps
- StormTech chambers
- StormTech manifolds and fittings

Important Notes:

- This installation guide provides the minimum requirements for proper installation of chambers. Non-adherence to this guide may result in damage to chambers during installation. Replacement of damaged chambers during or after backfilling is costly and very time consuming. It is recommended that all installers are familiar with this guide, and that the contractor inspects the chambers for distortion, damage and joint integrity as work progresses.
- Use of a dozer to push embedment stone between the rows of chambers may cause damage to chambers and is not an acceptable backfill method. Any chambers damaged by using the “dump and push” method are not covered under the StormTech standard warranty.
- Care should be taken in the handling of chambers and end caps. Avoid dropping, prying or excessive force on chambers during removal from pallet and initial placement.

Requirements for System Installation



Excavate bed and prepare subgrade per engineer's plans.



Place non-woven geotextile over prepared soils and up excavation walls. Install underdrains if required.



Place clean, crushed, angular stone foundation 6" (150 mm) min. Compact to achieve a flat surface.

Manifold, Scour Fabric and Chamber Assembly



Install manifolds and lay out ADS Plus Fabric at inlet rows. Place ADS Plus Fabric at each inlet end cap parallel to the row (min. 12.5 ft (3.8 m)). Place a continuous piece entire length of Isolator® Plus Row(s).



Align the first chamber and end cap of each row with inlet pipes. Contractor may choose to postpone stone placement around end chambers and leave ends of rows open for easy inspection of chambers during the backfill process.



Continue installing chambers by overlapping chamber end corrugations. Chamber joints are labeled "Lower Joint – Overlap Here" and "Build this direction – Upper Joint". Be sure that the chamber placement does not exceed the reach of the construction equipment used to place the stone. Maintain minimum 3" (75 mm) spacing between rows for SC-310 and SC-800, and 6" (150 mm) spacing for DC-780.

Attaching the End Caps



Lift the end of the chamber a few inches off the ground. With the curved face of the end cap facing outward, place the end cap into the chamber's end corrugation.

Prefabricated End Caps



24" (600 mm) inlets are the maximum size that can fit into a DC-780 or SC-800 end cap and must be prefabricated with a 24" (600 mm) pipe stub. SC-310 chambers with a 12" (300 mm) inlet pipe must use a prefabricated end cap with a 12" (300 mm) pipe stub. When used on an Isolator Row Plus, these end caps will contain a welded FLAMP (flared end ramp) that will lay on top of the ADS Plus fabric (shown above)

Isolator Row Plus



Place a continuous layer of ADS Plus fabric between the foundation stone and the Isolator Row Plus chambers, making sure the fabric lays flat and extends the entire width of the chamber feet.

Initial Anchoring of Chambers – Embedment Stone



Initial embedment shall be spotted along the center line of the chamber evenly anchoring the lower portion of the chamber. This is best accomplished with a stone conveyor or excavator reaching along the row.



No equipment shall be operated on the bed at this stage of the installation. Excavators must be located off the bed. Dump trucks shall not dump stone directly on to the bed. Dozers or loaders are not allowed on the bed at this time.

Backfill of Chambers – Embedment Stone

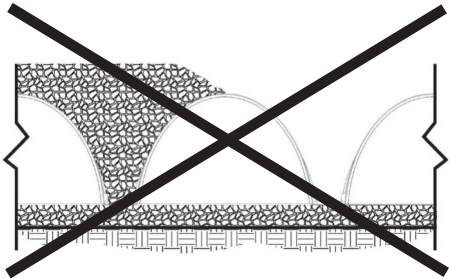

Uneven Backfill

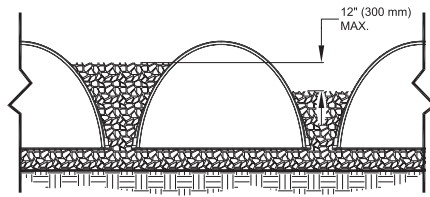

Even Backfill

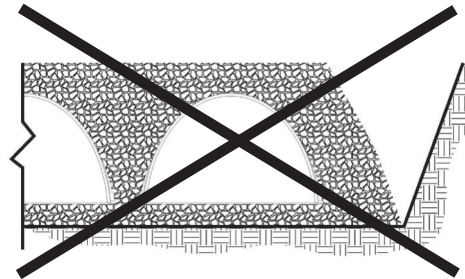

Perimeter Not Backfilled

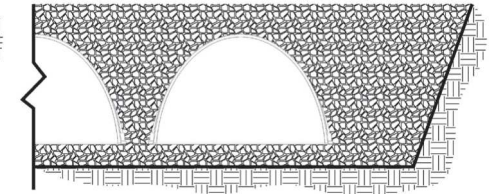

Perimeter Fully Backfilled

Backfill chambers evenly. Stone column height should never differ by more than 12" (300 mm) between adjacent chamber rows or between chamber rows and perimeter.

Perimeter stone must be brought up evenly with chamber rows. Perimeter must be fully backfilled, with stone extended horizontally to the excavation wall.

Backfill - Embedment Stone & Cover Stone



Continue evenly backfilling between rows and around perimeter until embedment stone reaches tops of chambers. Perimeter stone must extend horizontally to the excavation wall for both straight or sloped sidewalls. **Only after chambers have been backfilled to top of chamber and with a minimum 6" (150 mm) of cover stone on top of chambers can small dozers be used over the chambers for backfilling remaining cover stone.**

Small dozers and skid loaders may be used to finish grading stone backfill in accordance with ground pressure limits in Table 2. They must push material parallel to rows only. Never push perpendicular to rows. StormTech recommends that the contractor inspect chambers before placing final backfill. Any chambers damaged by construction shall be removed and replaced.

Final Backfill of Chambers – Fill Material



Install non-woven geotextile over stone. Geotextile must overlap 24" (600 mm) min. where edges meet. Compact each lift of backfill as specified in the site design engineer's drawings. Roller travel parallel with rows.

Inserta Tee Detail

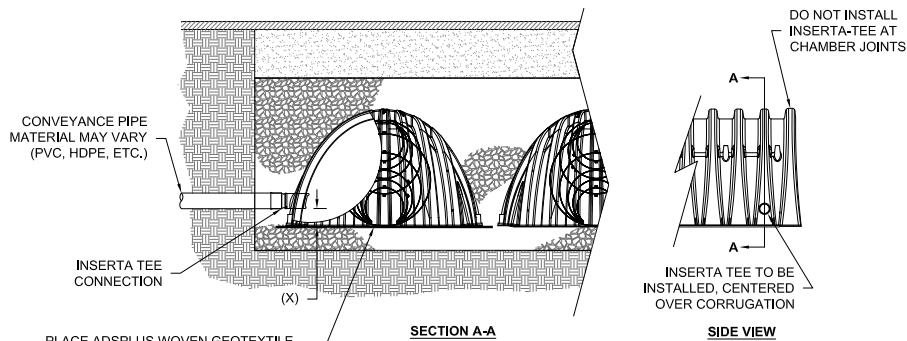

SECTION A-A

SIDE VIEW

CHAMBER	MAX DIAMETER OF INSERTA TEE	HEIGHT FROM BASE OF CHAMBER (X)
SC-310	6" (150 mm)	4" (100 mm)
SC-800	10" (250 mm)	4" (100 mm)
DC-780	10" (250 mm)	4" (100 mm)

INSERTA TEE FITTINGS AVAILABLE FOR SDR 26, SDR 35, SCH 40 IPS GASKETED & SOLVENT WELD, N-12, HP STORM, C-900 OR DUCTILE IRON

NOTES:

- PART NUMBERS WILL VARY BASED ON INLET PIPE MATERIALS. CONTACT STORMTECH FOR MORE INFORMATION.
- CONTACT ADS ENGINEERING SERVICES IF INSERTA TEE INLET MUST BE RAISED AS NOT ALL INVERTS ARE POSSIBLE.

StormTech Isolator Row Plus Detail

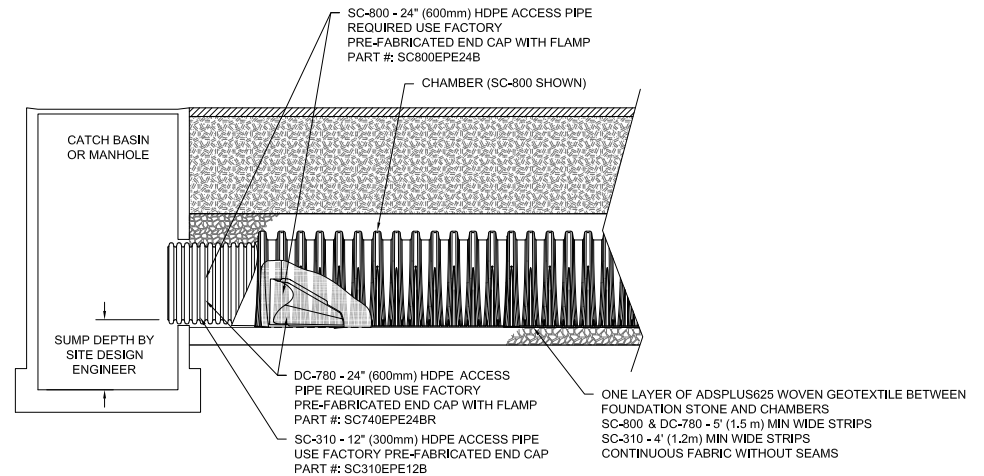

Table 1- Acceptable Fill Materials

Material Location	Description	AASHTO M43 Designation ¹	Compaction/Density Requirement
D Final Fill: Fill Material for layer 'D' starts from the top of the 'C' layer to the bottom of flexible pavement or unpaved finished grade above. Note that the pavement subbase may be part of the 'D' layer.	Any soil/rock materials, native soils or per engineer's plans. Check plans for pavement subgrade requirements.	N/A	Prepare per site design engineer's plans. Paved installations may have stringent material and preparation requirements.
C Initial Fill: Fill Material for layer 'C' starts from the top of the embedment stone ('B' layer) to 18" (450 mm) above the top of the chamber. Note that pavement subbase may be part of the 'C' layer.	Granular well-graded soil/aggregate mixtures, <35% fines or processed aggregate. Most pavement subbase materials can be used in lieu of this layer.	AASHTO M45 A-1, A-2-4, A-3 or AASHTO M43 ¹ 3, 357, 4, 467, 5, 56, 57, 6, 67, 68, 7, 78, 8, 89, 9, 10	Begin compaction after min. 12" (300 mm) of material over the chambers is reached. Compact additional layers in 6" (150 mm) max. lifts to a min. 95% Proctor density for well-graded material and 95% relative density for processed aggregate materials. Roller gross vehicle weight not to exceed 12,000 lbs (53 kN). Dynamic force not to exceed 20,000 lbs (89 kN)
B Embedment Stone: Embedment Stone surrounding chambers from the foundation stone to the 'C' layer above.	Clean, crushed, angular stone or Recycled Concrete ⁴	AASHTO M43 ¹ 3, 357, 4, 467, 5, 56, 57	No compaction required.
A Foundation Stone: Foundation Stone below the chambers from the subgrade up to the foot (bottom) of the chamber.	Clean, crushed, angular stone or Recycled Concrete ⁴	AASHTO M43 ¹ 3, 357, 4, 467, 5, 56, 57	Place and compact in 6" (6") lifts using two full coverages with a vibratory compactor. ^{2,3}

Please Note:

1. The listed AASHTO designations are for gradations only. The stone must also be clean, crushed, angular. For example, a specification for #4 stone would state: "clean, crushed, angular no. 4 (AASHTO M43) stone".
2. StormTech compaction requirements are met for 'A' location materials when placed and compacted in 6" (150 mm) (max) lifts using two full coverages with a vibratory compactor.
3. Where infiltration surfaces may be comprised by compaction, for standard installations and standard design load conditions, a flat surface may be achieved by raking or dragging without compaction equipment. For special load designs, contact StormTech for compaction requirements.
4. Where recycled concrete aggregate is used in layers 'A' or 'B' the material should also meet the acceptable criteria outlined in ADS Technical Note 6.20 "Recycled Concrete Structural Backfill".

Figure 2 - Fill Material Locations

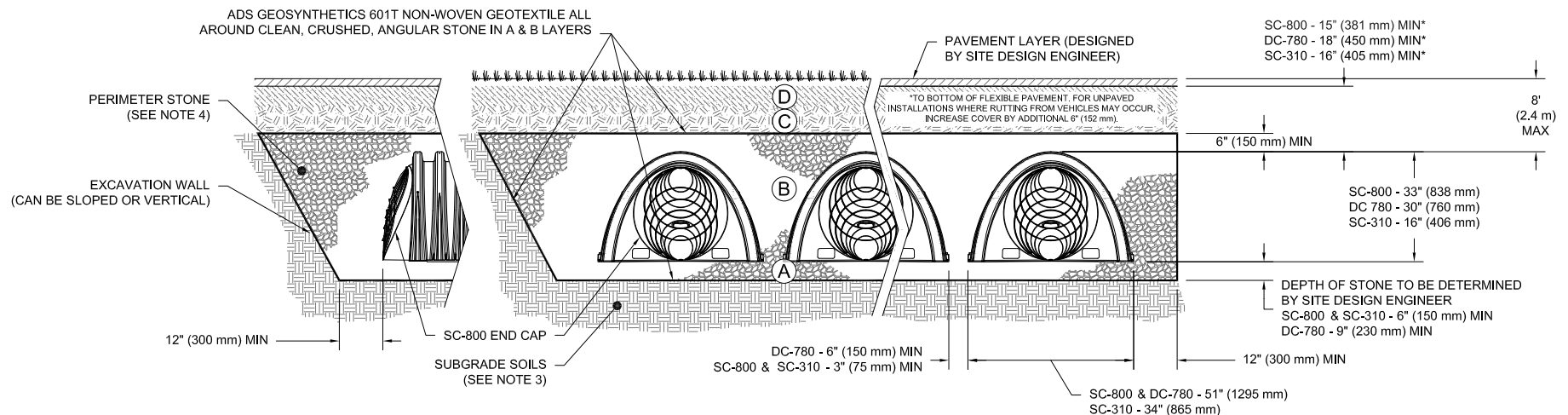
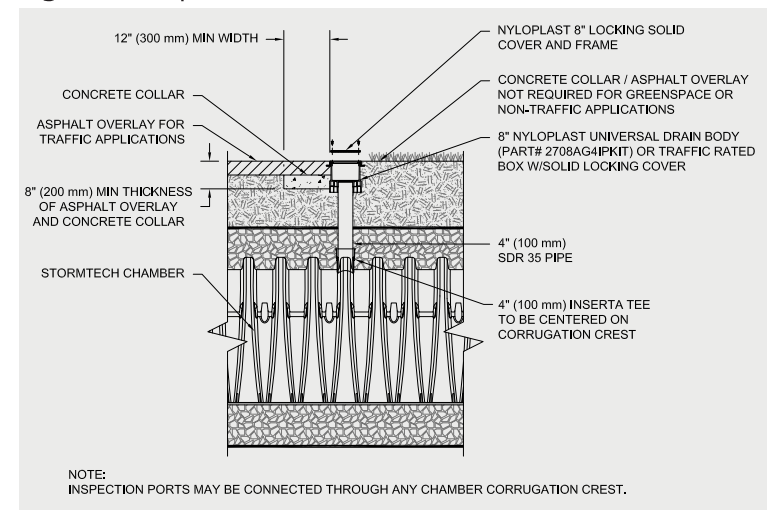

Figure 1- Inspection Port Detail



Notes:

- 36" (900 mm) of stabilized cover materials over the chambers is recommended during the construction phase if general construction activities, such as full dump truck travel and dumping, are to occur over the bed.
- During paving operations, dump truck axle loads on 18" (450 mm) of cover may be necessary. Precautions should be taken to avoid rutting of the road base layer, to ensure that compaction requirements have been met, and that a minimum of 18" (450 mm) of cover exists over the chambers. Contact StormTech for additional guidance on allowable axle loads during paving.
- Ground pressure for track dozers is the vehicle operating weight divided by total ground contact area for both tracks. Excavators will exert higher ground pressures based on loaded bucket weight and boom extension.
- Mini-excavators (< 8,000lbs/3,628 kg) can be used with at least 12" (300 mm) of stone over the chambers and are limited by the maximum ground pressures in Table 2 based on a full bucket at maximum boom extension.
- Storage of materials such as construction materials, equipment, spoils, etc. should not be located over the StormTech system. The use of equipment over the StormTech system not covered in Table 2 (ex. soil mixing equipment, cranes, etc) is limited. Please contact StormTech for more information.
- Allowable track loads based on vehicle travel only. Excavators shall not operate on chamber beds until the total backfill reaches 3 feet (900 mm) over the entire bed.

Table 2 - Maximum Allowable Construction Vehicle Loads⁶

Material Location	Fill Depth over Chambers in. (mm)	Maximum Allowable Wheel Loads		Maximum Allowable Track Loads ⁶		Maximum Allowable Roller Loads
		Max Axle Load for Trucks lbs (kN)	Max Wheel Load for Loaders lbs (kN)	Track Width in. (mm)	Max Ground Pressure psf (kPa)	Max Drum Weight or Dynamic Force lbs (kN)
Ⓓ Final Fill Material	36" (900) Compacted	32,000 (142)	16,000 (71)	12" (305)	3880 (186)	38,000 (169)
				18" (457)	2640 (126)	
				24" (610)	2040 (97)	
				30" (762)	1690 (81)	
				36" (914)	1470 (70)	
Ⓒ Initial Fill Material	24" (600) Compacted	32,000 (142)	16,000 (71)	12" (305)	2690 (128)	20,000 (89)
				18" (457)	1880 (90)	
				24" (610)	1490 (71)	
				30" (762)	1280 (61)	
				36" (914)	1150 (55)	
	24" (600) Loose/Dumped	32,000 (142)	16,000 (71)	12" (305)	2390 (114)	20,000 (89) Roller gross vehicle weight not to exceed 12,000 lbs. (53 kN)
				18" (457)	1700 (81)	
				24" (610)	1370 (65)	
				30" (762)	1190 (57)	
18" (450)	32,000 (142)	16,000 (71)	12" (305)	2110 (101)	20,000 (89) Roller gross vehicle weight not to exceed 12,000 lbs. (53 kN)	
			18" (457)	1510 (72)		
			24" (610)	1250 (59)		
			30" (762)	1100 (52)		
			36" (914)	1020 (48)		
Ⓑ Embedment Stone	12" (300)	16,000 (71)	NOT ALLOWED	12" (305)	1540 (74)	20,000 (89) Roller gross vehicle weight not to exceed 12,000 lbs. (53 kN)
				18" (457)	1190 (57)	
				24" (610)	1010 (48)	
				30" (762)	910 (43)	
				36" (914)	840 (40)	
	6" (150)	8,000 (35)	NOT ALLOWED	12" (305)	1070 (51)	NOT ALLOWED
				18" (457)	900 (43)	
				24" (610)	800 (38)	
				30" (762)	760 (36)	
				36" (914)	720 (34)	

Table 3 - Placement Methods and Descriptions

Material Location	Placement Methods/Restrictions	Wheel Load Restrictions	Track Load Restrictions	Roller Load Restrictions
		See Table 2 for Maximum Construction Loads		
Ⓓ Final Fill Material	A variety of placement methods may be used. All construction loads must not exceed the maximum limits in Table 2.	36" (900 mm) minimum cover required for dump trucks to dump over chambers.	Dozers to push parallel to rows until 36" (900mm) compacted cover is reached. ⁴	Roller travel parallel to rows only until 36" (900 mm) compacted cover is reached.
Ⓒ Initial Fill Material	Excavator positioned off bed recommended. Small excavator allowed over chambers. Small dozer allowed.	Asphalt can be dumped into paver when compacted pavement subbase reaches 18" (450 mm) above top of chambers.	Small LGP track dozers & skid loaders allowed to grade cover stone with at least 6" (150 mm) stone under tracks at all times. Equipment must push parallel to rows at all times.	Use dynamic force of roller only after compacted fill depth reaches 12" (300 mm) over chambers. Roller travel parallel to chamber rows only.
Ⓑ Embedment Stone	No equipment allowed on bare chambers. Use excavator or stone conveyor positioned off bed or on foundation stone to evenly fill around all chambers to at least the top of chambers.	No wheel loads allowed. Material must be placed outside the limits of the chamber bed.	No tracked equipment is allowed on chambers until a min. 6" (150 mm) cover stone is in place.	No rollers allowed.
Ⓐ Foundation Stone	No StormTech restrictions. Contractor responsible for any conditions or requirements by others relative to subgrade bearing capacity, dewatering or protection of subgrade.			



StormTech® Standard Limited Warranty

STANDARD LIMITED WARRANTY OF STORMTECH LLC (“STORMTECH”): PRODUCTS

- (A) This Limited Warranty applies solely to the StormTech chambers and end plates manufactured by StormTech and sold to the original purchaser (the “Purchaser”). The chambers and end plates are collectively referred to as the “Products.”
- (B) The structural integrity of the Products, when installed strictly in accordance with StormTech’s written installation instructions at the time of installation, are warranted to the Purchaser against defective materials and workmanship for one (1) year from the date of purchase. Should a defect appear in the Limited Warranty period, the Purchaser shall provide StormTech with written notice of the alleged defect at StormTech’s corporate headquarters within ten (10) days of the discovery of the defect. The notice shall describe the alleged defect in reasonable detail. StormTech agrees to supply replacements for those Products determined by StormTech to be defective and covered by this Limited Warranty. The supply of replacement products is the sole remedy of the Purchaser for breaches of this Limited Warranty. StormTech’s liability specifically excludes the cost of removal and/or installation of the Products.
- (C) THIS LIMITED WARRANTY IS EXCLUSIVE. THERE ARE NO OTHER WARRANTIES WITH RESPECT TO THE PRODUCTS, INCLUDING NO IMPLIED WARRANTIES OF MERCHANTABILITY OR OF FITNESS FOR A PARTICULAR PURPOSE.
- (D) This Limited Warranty only applies to the Products when the Products are installed in a single layer. UNDER NO CIRCUMSTANCES, SHALL THE PRODUCTS BE INSTALLED IN A MULTI-LAYER CONFIGURATION.
- (E) No representative of StormTech has the authority to change this Limited Warranty in any manner or to extend this Limited Warranty. This Limited Warranty does not apply to any person other than to the Purchaser.
- (F) Under no circumstances shall StormTech be liable to the Purchaser or to any third party for product liability claims; claims arising from the design, shipment, or installation of the Products, or the cost of other goods or services related to the purchase and installation of the Products. For this Limited Warranty to apply, the Products must be installed in accordance with all site conditions required by state and local codes; all other applicable laws; and StormTech’s written installation instructions.
- (G) THE LIMITED WARRANTY DOES NOT EXTEND TO INCIDENTAL, CONSEQUENTIAL, SPECIAL OR INDIRECT DAMAGES. STORMTECH SHALL NOT BE LIABLE FOR PENALTIES OR LIQUIDATED DAMAGES, INCLUDING LOSS OF PRODUCTION AND PROFITS; LABOR AND MATERIALS; OVERHEAD COSTS; OR OTHER LOSS OR EXPENSE INCURRED BY THE PURCHASER OR ANY THIRD PARTY. SPECIFICALLY EXCLUDED FROM LIMITED WARRANTY COVERAGE ARE DAMAGE TO THE PRODUCTS ARISING FROM ORDINARY WEAR AND TEAR; ALTERATION, ACCIDENT, MISUSE, ABUSE OR NEGLIGENCE; THE PRODUCTS BEING SUBJECTED TO VEHICLE TRAFFIC OR OTHER CONDITIONS WHICH ARE NOT PERMITTED BY STORMTECH’S WRITTEN SPECIFICATIONS OR INSTALLATION INSTRUCTIONS; FAILURE TO MAINTAIN THE MINIMUM GROUND COVERS SET FORTH IN THE INSTALLATION INSTRUCTIONS; THE PLACEMENT OF IMPROPER MATERIALS INTO THE PRODUCTS; FAILURE OF THE PRODUCTS DUE TO IMPROPER SITING OR IMPROPER SIZING; OR ANY OTHER EVENT NOT CAUSED BY STORMTECH. A PRODUCT ALSO IS EXCLUDED FROM LIMITED WARRANTY COVERAGE IF SUCH PRODUCT IS USED IN A PROJECT OR SYSTEM IN WHICH ANY GEOTEXTILE PRODUCTS OTHER THAN THOSE PROVIDED BY ADVANCED DRAINAGE SYSTEMS ARE USED. THIS LIMITED WARRANTY REPRESENTS STORMTECH’S SOLE LIABILITY TO THE PURCHASER FOR CLAIMS RELATED TO THE PRODUCTS, WHETHER THE CLAIM IS BASED UPON CONTRACT, TORT, OR OTHER LEGAL THEORY.



Drainage



Filtration



Separation

ADS 0601T/O NONWOVEN GEOTEXTILE SPECIFICATION

Scope

This specification describes ADS 0601T/O nonwoven geotextile.

Filter Fabric Requirements

ADS 0601T/O is an orange nonwoven geotextile composed of polypropylene fibers, which are formed into a stable network such that the fibers retain their relative position. ADS 0601T/O is inert to biological degradation and resists naturally encountered chemicals, alkali and acids. ADS 0601T/O conforms to the physical property values listed below:

Filter Fabric Properties

Property	Test Method	Unit	Typical Value ¹ MD	Typical Value ¹ CD
Grab Tensile Strength	ASTM D4632	lbs (N)	175 (779)	175 (779)
Grab Tensile Elongation	ASTM D4632	%	75	75
Trapezoid Tear Strength	ASTM D4533	lbs (N)	85 (378)	85 (378)
CBR Puncture Strength	ASTM D6241	lbs (N)	480 (2136)	480 (2136)
Permittivity	ASTM D4491	sec ⁻¹	1.5	1.5
Flow Rate	ASTM D4491	gal/min/ft ² (l/min/m ²)	105 (4278)	105 (4278)
UV Resistance (at 500 hours) ¹	ASTM D4355	% strength retained	80	80

Physical Properties

Property	Test Method	Unit	Typical Value ²
Weight	ASTM D5161	oz/yd ² (g/m ²)	6.5 (220)
Thickness	ASTM D5199	mils (mm)	65 (1.7)
Roll Dimensions (W x L)	-	ft (m)	15 x 300 (4.5 x 91)
Roll Area	-	yd ² (m ²)	500 (418)
Estimated Roll Weight	-	lb (kg)	220 (100)

¹ Modified, Minimum Test Value

² ASTM D4439 Standard Terminology for Geosynthetics: typical value, *n-for geosynthetics*, the mean value calculated from documented manufacturing quality control test results for a defined population obtained from one test method associated with on specific property.

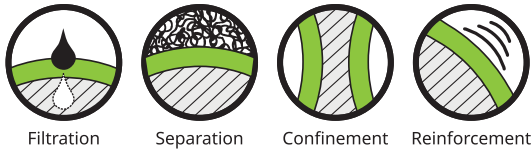

ADS PLUS WOVEN GEOTEXTILE SPECIFICATION

For use with StormTech® Isolator® Row Plus

Scope

This specification describes ADS Plus woven geotextile.

ADS Plus woven geotextile fabrics are woven polypropylene materials offering optimum performance when used in stabilization applications. Produced from first quality raw materials, they provide the perfect balance of strength and separation in styles capable of functioning exceptionally well in a wide range of performance requirements.

Filter Fabric Properties

Property ¹	Test Method	Unit	M.A.R.V. (Minimum Average Roll Value) ²
Weight	ASTM D5261	oz/yd ² (g/m ²)	8.0 (271.25)
Grab Tensile Strength	ASTM D4632	lbs (kN)	325 (1.45)
Grab Elongation	ASTM D4632	%	15
Trapezoidal Tear Strength	ASTM D4533	lbs (kN)	125 (0.89)
CBR Puncture Resistance	ASTM D6241	lbs (kN)	1,124 (5.0)

1. The property values listed above are subject to change without notice.

2. Minimum Average Roll Values (MARV) is calculated as the average minus two standard deviations. Statistically, it yields approximately 97.5% degree of confidence that any samples taken from quality assurance testing will meet or exceed the values described above.

Dimensions

ADS Plus shall be delivered to the jobsite in roll form with each roll individually identified and nominally measuring 12.5' (3.8 m) width x 360' (110 m) length for Plus125 and 6.25' (1.9 m) width x 360' (110 m) length for Plus625.

User Inputs

Chamber Model:	SC-800
Outlet Control Structure:	Yes
Project Name:	124147
Engineer:	Lucas Wilson
Project Location:	Ontario
Measurement Type:	Metric
Required Storage Volume:	14.01 cubic meters.
Stone Porosity:	40%
Stone Foundation Depth:	153 mm.
Stone Above Chambers:	153 mm.
Design Constraint Dimensions:	(5.00 m. x 6.70 m.)

Results

System Volume and Bed Size

Installed Storage Volume:	17.87 cubic meters.
Storage Volume Per Chamber:	1.44 cubic meters.
Number Of Chambers Required:	5 [CB 2]
Number Of End Caps Required:	6
Chamber Rows:	3
Maximum Length:	6.68 m.
Maximum Width:	4.84 m.
Approx. Bed Size Required:	28.90 square meters.
Average Cover Over Chambers:	N/A .

System Components

Amount Of Stone Required:	26 cubic meters
Volume Of Excavation (Not Including Fill):	34 cubic meters
Total Non-woven Geotextile Required:	101 square meters
Woven Geotextile Required (excluding Isolator Row):	18 square meters
Woven Geotextile Required (Isolator Row):	9 square meters
Total Woven Geotextile Required:	27 square meters
Impervious Liner Required:	0 square meters

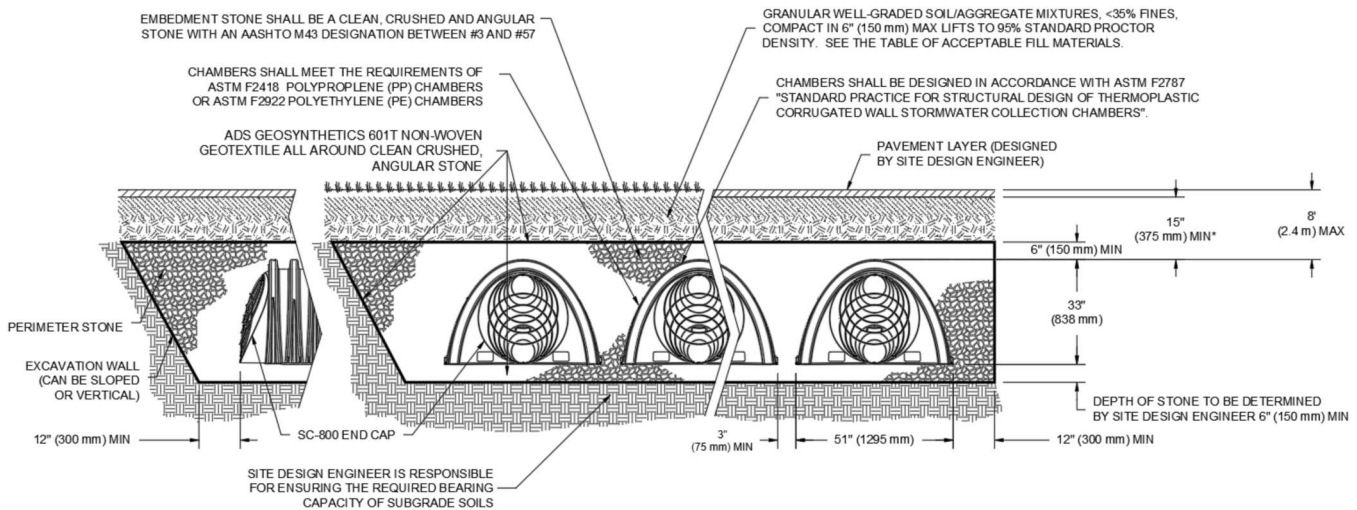

*MINIMUM COVER TO BOTTOM OF FLEXIBLE PAVEMENT. FOR UNPAVED INSTALLATIONS WHERE RUTTING FROM VEHICLES MAY OCCUR, INCREASE COVER TO 24" (600 mm).

User Inputs

Chamber Model:	SC-800
Outlet Control Structure:	Yes
Project Name:	124147
Engineer:	Lucas Wilson
Project Location:	Ontario
Measurement Type:	Metric
Required Storage Volume:	12.51 cubic meters.
Stone Porosity:	40%
Stone Foundation Depth:	153 mm.
Stone Above Chambers:	153 mm.
Design Constraint Dimensions:	(5.00 m. x 4.60 m.)

Results

System Volume and Bed Size

Installed Storage Volume:	12.90 cubic meters.
Storage Volume Per Chamber:	1.44 cubic meters.
Number Of Chambers Required:	3 [CB 5]
Number Of End Caps Required:	6
Chamber Rows:	3
Maximum Length:	4.52 m.
Maximum Width:	4.84 m.
Approx. Bed Size Required:	21.79 square meters.
Average Cover Over Chambers:	N/A .

System Components

Amount Of Stone Required:	21 cubic meters
Volume Of Excavation (Not Including Fill):	25 cubic meters
Total Non-woven Geotextile Required:	78 square meters
Woven Geotextile Required (excluding Isolator Row):	18 square meters
Woven Geotextile Required (Isolator Row):	5 square meters
Total Woven Geotextile Required:	23 square meters
Impervious Liner Required:	0 square meters

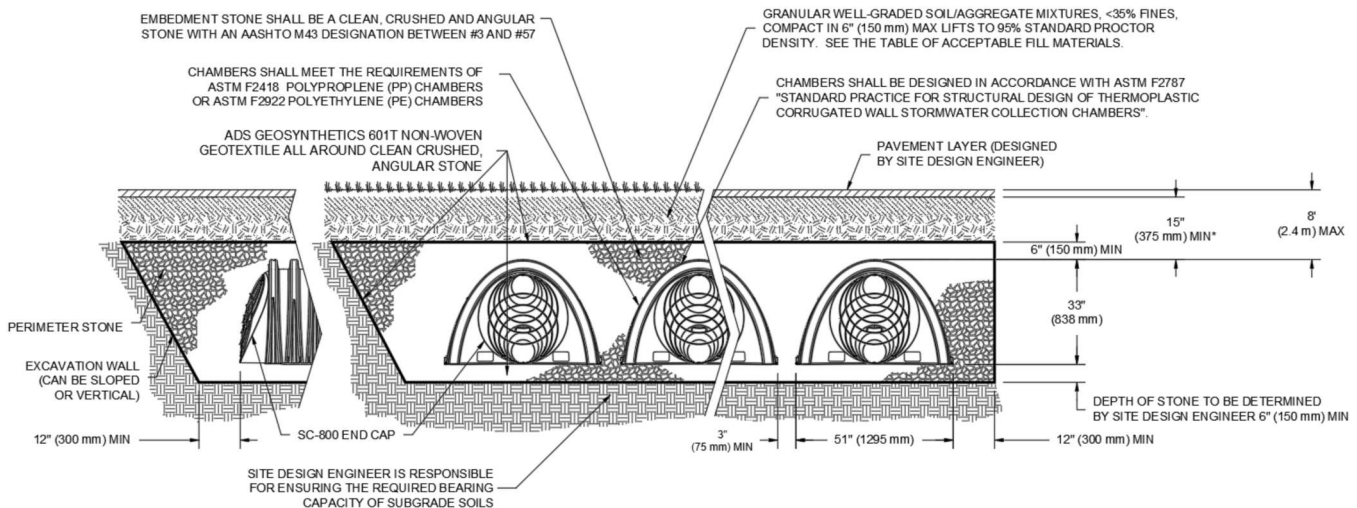

*MINIMUM COVER TO BOTTOM OF FLEXIBLE PAVEMENT. FOR UNPAVED INSTALLATIONS WHERE RUTTING FROM VEHICLES MAY OCCUR, INCREASE COVER TO 24" (600 mm).

User Inputs

Chamber Model:	SC-800
Outlet Control Structure:	No
Project Name:	124147
Engineer:	undefined undefined
Project Location:	Ontario
Measurement Type:	Metric
Required Storage Volume:	8.70 cubic meters.
Stone Porosity:	40%
Stone Foundation Depth:	153 mm.
Stone Above Chambers:	153 mm.
Design Constraint Dimensions:	(3.31 m. x 4.60 m.)

Results

System Volume and Bed Size

Installed Storage Volume:	8.71 cubic meters.
Storage Volume Per Chamber:	1.44 cubic meters.
Number Of Chambers Required:	2 [CB 3, 4 & 6]
Number Of End Caps Required:	4
Chamber Rows:	2
Maximum Length:	4.52 m.
Maximum Width:	3.28 m.
Approx. Bed Size Required:	14.78 square meters.
Average Cover Over Chambers:	N/A .

System Components

Amount Of Stone Required:	14 cubic meters
Volume Of Excavation (Not Including Fill):	17 cubic meters
Total Non-woven Geotextile Required:	57 square meters
Woven Geotextile Required (excluding Isolator Row):	9 square meters
Woven Geotextile Required (Isolator Row):	5 square meters
Total Woven Geotextile Required:	14 square meters
Impervious Liner Required:	0 square meters

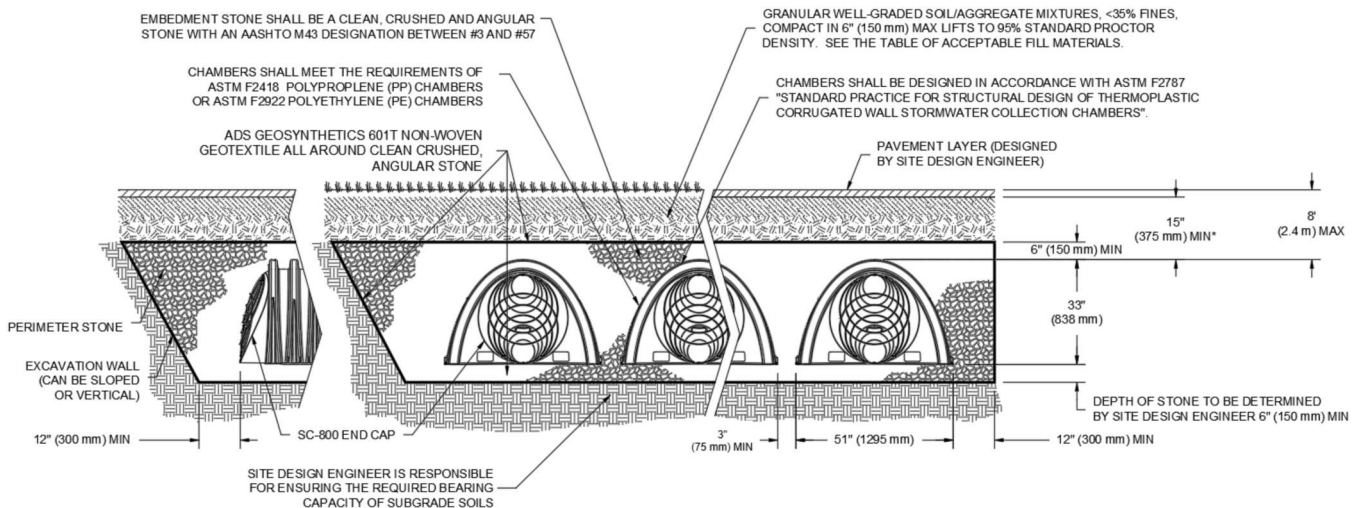

*MINIMUM COVER TO BOTTOM OF FLEXIBLE PAVEMENT. FOR UNPAVED INSTALLATIONS WHERE RUTTING FROM VEHICLES MAY OCCUR, INCREASE COVER TO 24" (600 mm).

User Inputs

Chamber Model:	SC-800
Outlet Control Structure:	Yes
Project Name:	
Engineer:	Lucas Wilson
Project Location:	
Measurement Type:	Metric
Required Storage Volume:	19.00 cubic meters.
Stone Porosity:	40%
Stone Foundation Depth:	153 mm.
Stone Above Chambers:	153 mm.
Design Constraint Dimensions:	(8.01 m. x 5.00 m.)

Results

System Volume and Bed Size

Installed Storage Volume:	19.34 cubic meters.
Storage Volume Per Chamber:	1.44 cubic meters.
Number Of Chambers Required:	5 [CB 1]
Number Of End Caps Required:	10
Chamber Rows:	5
Maximum Length:	4.52 m.
Maximum Width:	7.58 m.
Approx. Bed Size Required:	31.63 square meters.
Average Cover Over Chambers:	N/A .

System Components

Amount Of Stone Required:	29 cubic meters
Volume Of Excavation (Not Including Fill):	37 cubic meters
Total Non-woven Geotextile Required:	110 square meters
Woven Geotextile Required (excluding Isolator Row):	27 square meters
Woven Geotextile Required (Isolator Row):	5 square meters
Total Woven Geotextile Required:	32 square meters
Impervious Liner Required:	0 square meters

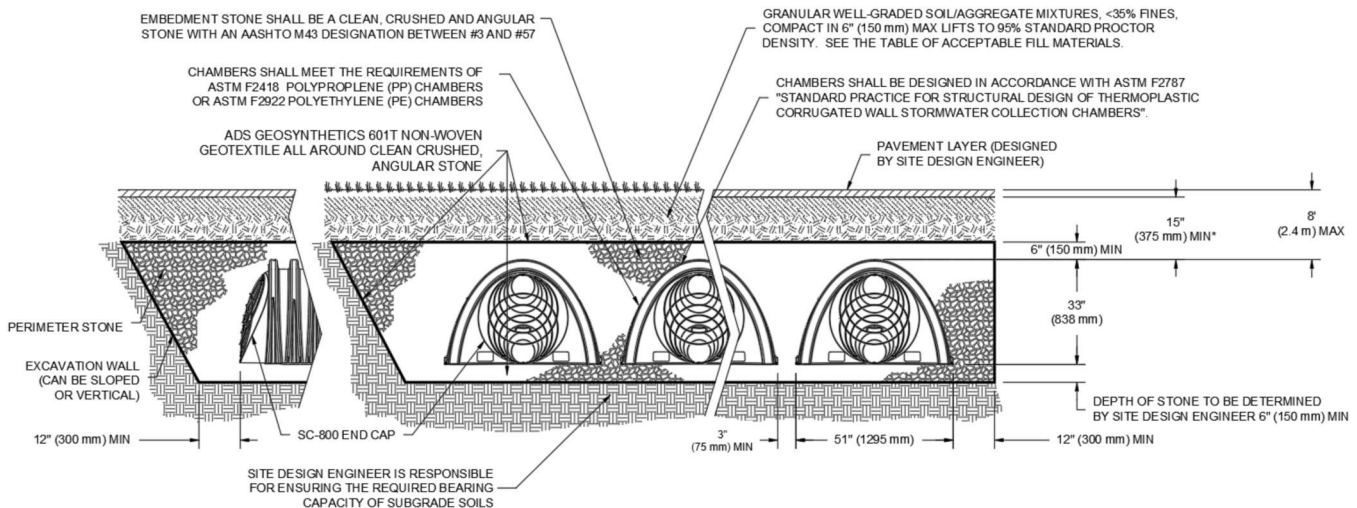

*MINIMUM COVER TO BOTTOM OF FLEXIBLE PAVEMENT. FOR UNPAVED INSTALLATIONS WHERE RUTTING FROM VEHICLES MAY OCCUR, INCREASE COVER TO 24" (600 mm).

3400 WOODROFFE AVE (124147)
 WOODROFFE AVENUE STORM SEWER - MH201 TO STRANDHERD DRIVE
 (POST DEVELOPMENT)
 100-YEAR HGL PROFILE

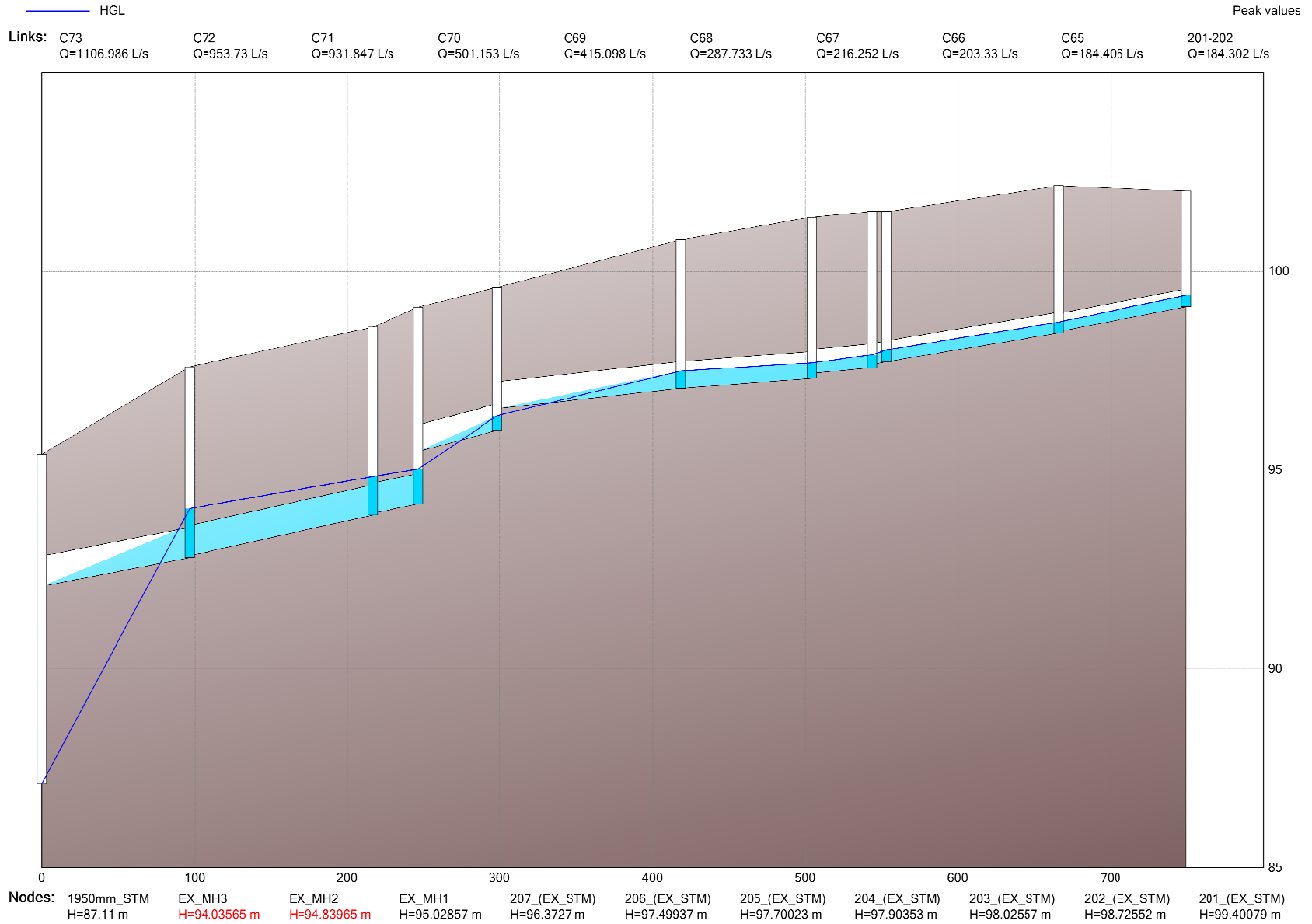

3400 WOODROFFE AVE (124147)
 WOODROFFE AVENUE STORM SEWER - MH201 TO STRANDHERD DRIVE
 (PRE DEVELOPMENT)
 100-YEAR HGL PROFILE

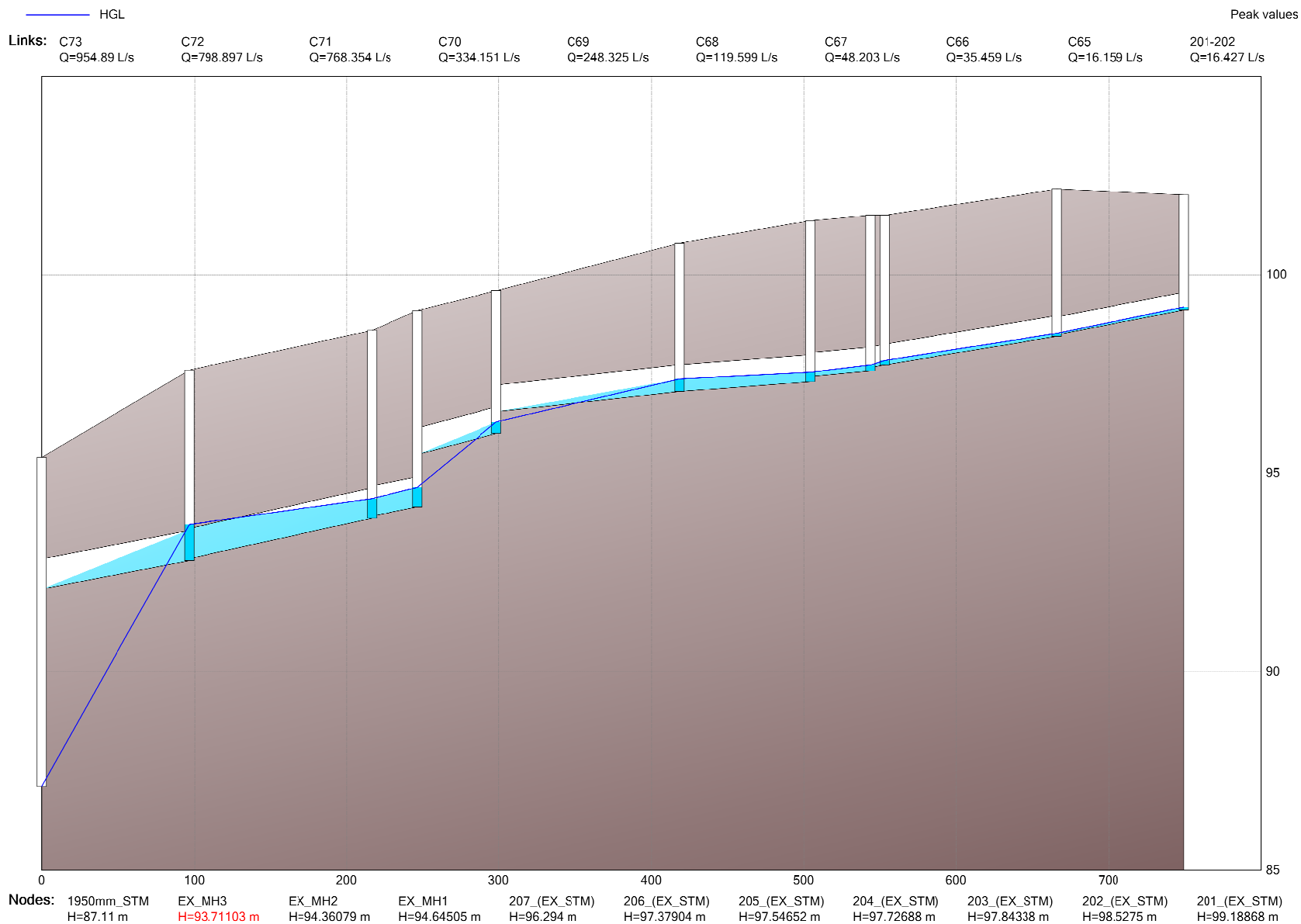

3400 WOODROFFE AVE (124147)
WOODROFFE AVENUE STORM SEWER - MH208 TO WHITEWATER
STREET (POST DEVELOPMENT)
100-YEAR HGL PROFILE

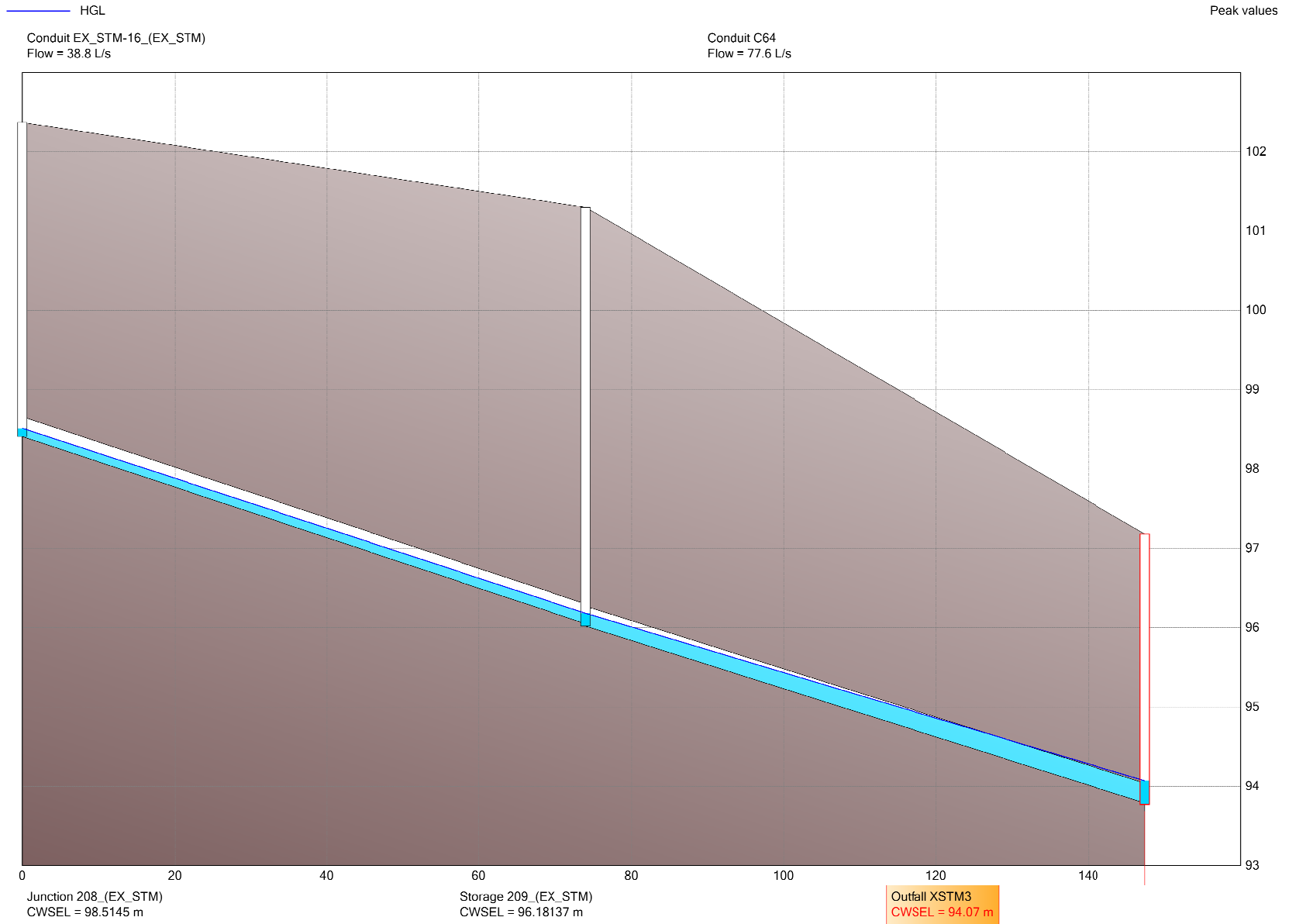

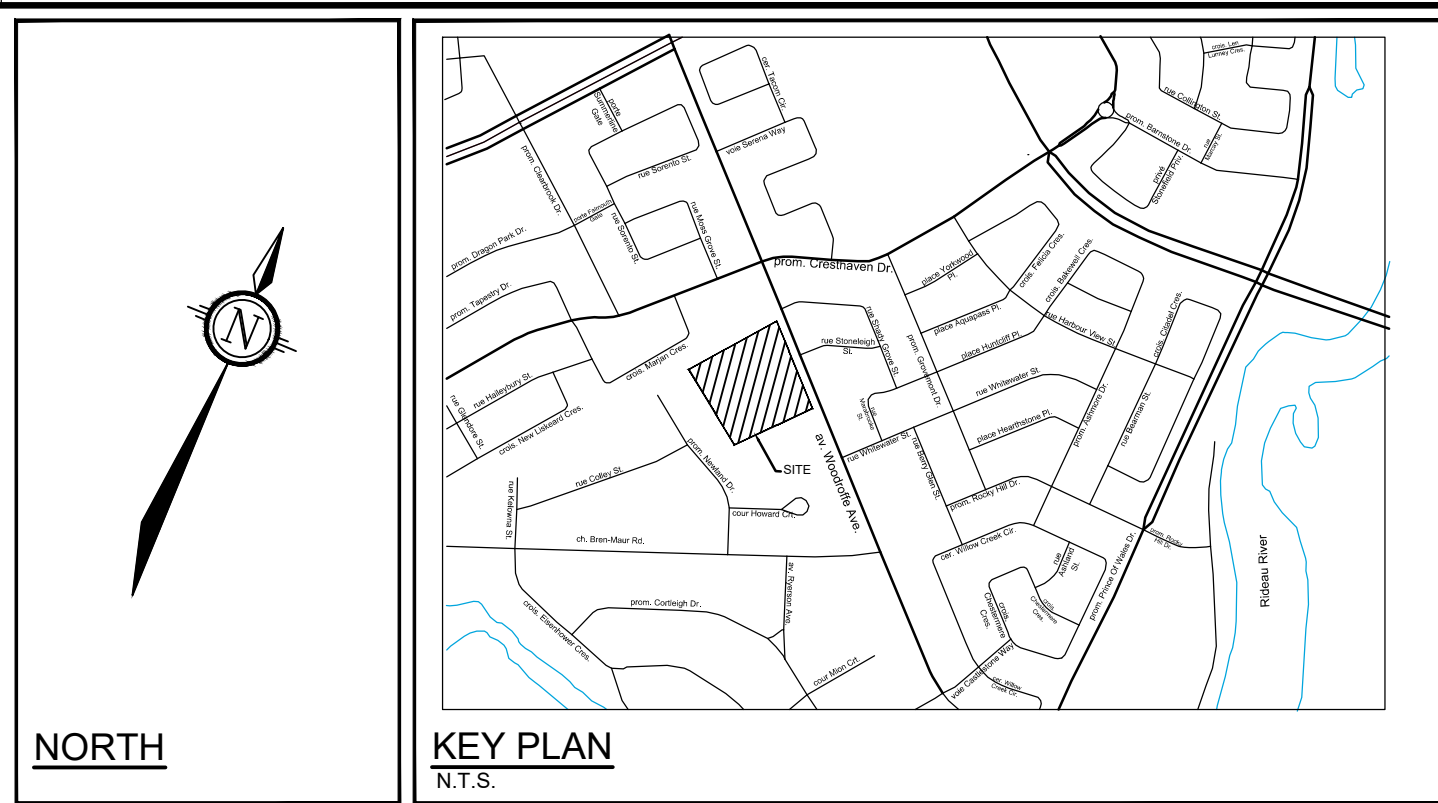
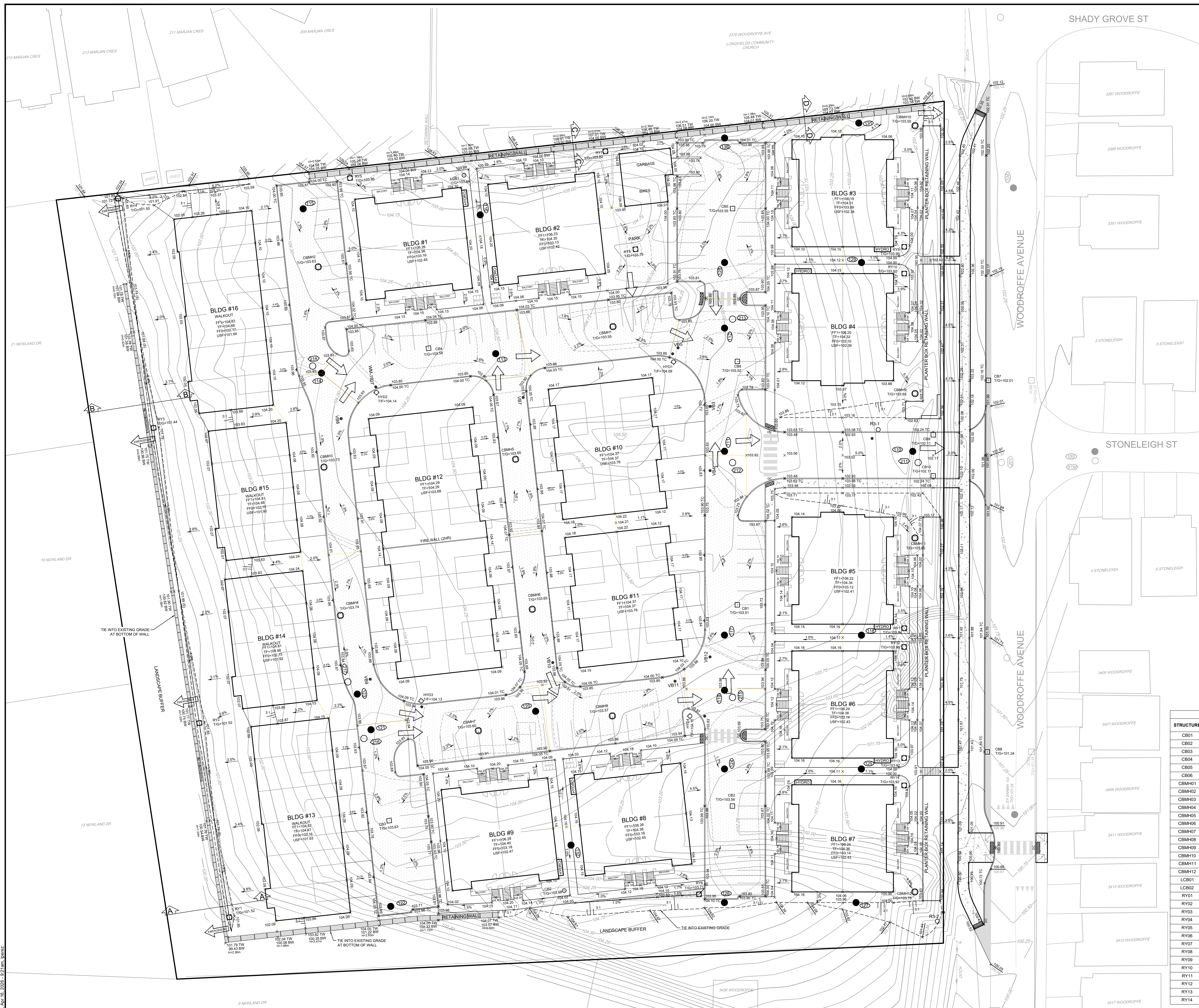

- LEGEND**
- 2.2% PROPOSED GRADE AND DIRECTION OF FLOW
 - 76.90 PROPOSED ELEVATION
 - 77.50 PROPOSED ELEVATION
 - 77.50 X EXISTING ELEVATION
 - 1.1% TERRACING (3:1 MAX)
 - PROPOSED RETAINING WALL
 - MAJOR OVERLAND FLOW DIRECTION
 - EMERGENCY FLOW DIRECTION
 - EXISTING CONTOUR AND ELEVATION
 - PROPOSED SANITARY MANHOLE
 - PROPOSED STORM MANHOLE
 - PROPOSED CATCHBASIN
 - RY1 PROPOSED REAR YARD CATCHBASIN WITH TOP OF GRATE ELEVATION
 - VB PROPOSED VALVE & VALVE BOX LOCATION
 - HYD PROPOSED HYDRANT WITH TOP OF FLANGE ELEVATION
 - FF1 FINISHED FLOOR ELEVATION - 1ST FLOOR
 - TF TOP OF FOUNDATION
 - FF0 FINISHED FLOOR ELEVATION - BASEMENT
 - USF UNDERSIDE OF FOOTING ELEVATION
 - TW TOP OF WALL ELEVATION
 - BW BOTTOM OF WALL ELEVATION
 - MAX STATIC PONDING LIMITS
 - 100-YR PONDING LIMITS
 - 100-YR +20% PONDING LIMITS

PAVEMENT STRUCTURE:

- 40mm ASPHALT SP12.5
- 50mm ASPHALT SP19.0
- 150mm GRAN "A"
- 450mm GRAN "B" TYPE II
- 600mm TOTAL DEPTH

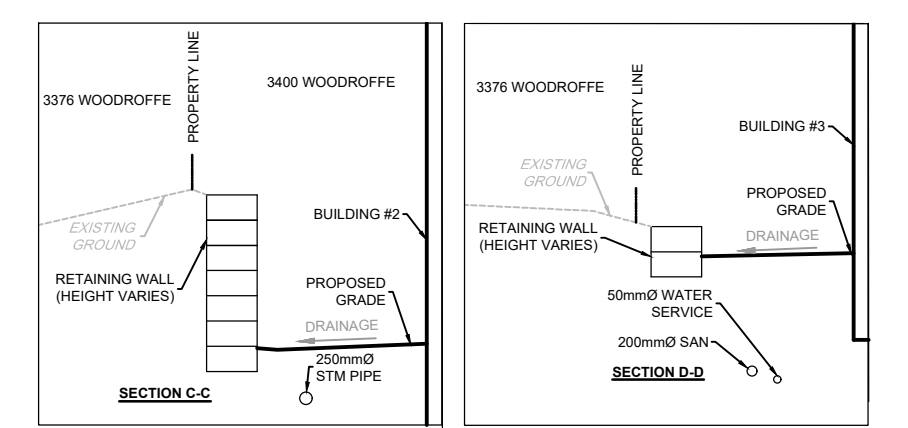
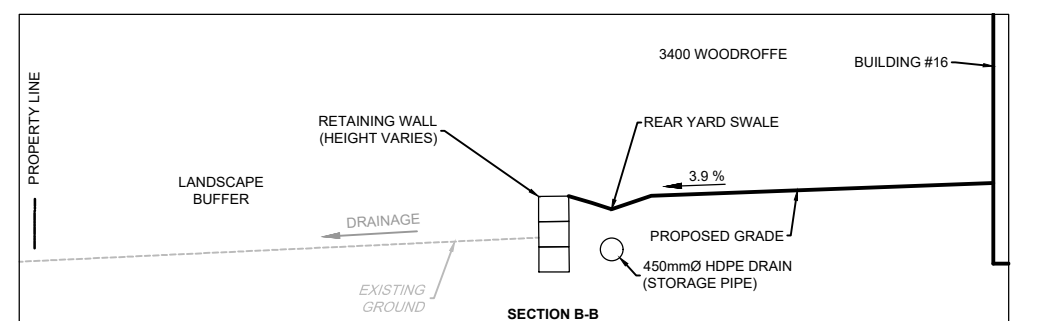
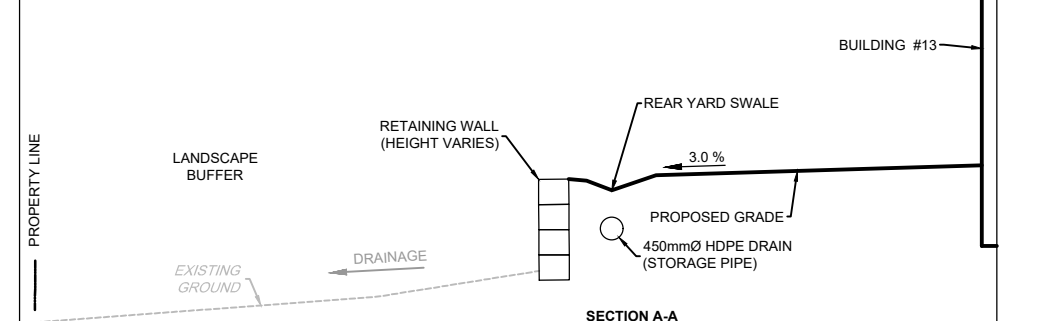

STRUCTURE	PONDING				MAX STATIC PONDING ELEVATION	MAX STATIC PONDING DEPTH (m)
	100 YEAR PONDING ELEVATION	100 YEAR PONDING DEPTH (m)	100 YEAR +20% PONDING ELEVATION	100 YEAR +20% PONDING DEPTH (m)		
CB01	103.79	0.28	103.94	0.33	103.83	0.32
CB02	103.80	0.24	103.86	0.30	103.86	0.30
CB03	103.83	0.20	103.87	0.24	103.93	0.30
CB04	103.73	0.18	103.87	0.32	103.88	0.33
CB05	103.76	0.21	103.81	0.26	103.85	0.30
CB06	103.69	0.17	103.77	0.25	103.82	0.30
CBM#01	103.70	0.15	103.74	0.19	103.85	0.30
CBM#02	103.92	0.29	103.94	0.31	103.93	0.30
CBM#03	103.94	0.21	103.95	0.22	103.93	0.20
CBM#04	103.95	0.21	103.96	0.22	103.94	0.20
CBM#05	103.87	0.22	103.91	0.26	103.90	0.25
CBM#06	103.91	0.26	103.93	0.28	103.91	0.26
CBM#07	103.77	0.17	103.86	0.26	103.90	0.30
CBM#08	103.76	0.19	103.85	0.28	103.87	0.30
CBM#09	103.22	0.00	103.60	0.00	103.73	0.08
CBM#10	103.23	0.00	103.61	0.11	103.56	0.08
CBM#11	103.60	0.00	103.88	0.00	103.99	0.04
CBM#12	103.60	0.00	103.88	0.10	103.83	0.05
LCB01	103.92	0.06	103.95	0.09	103.94	0.08
LCB02	103.80	0.00	103.86	0.00	104.05	0.07
RY01	101.73	0.21	101.81	0.29	101.79	0.27
RY02	101.73	0.21	101.81	0.29	101.77	0.25
RY03	101.73	0.29	101.77	0.33	101.75	0.31
RY04	101.73	0.23	101.77	0.27	101.72	0.22
RY05	103.92	0.06	103.95	0.09	103.95	0.09
RY06	103.80	0.08	103.86	0.14	103.86	0.24
RY07	103.92	0.10	103.95	0.13	103.95	0.13
RY08	103.82	0.03	103.87	0.08	103.94	0.15
RY09	103.22	0.00	103.61	0.00	104.00	0.05
RY10	103.22	0.00	103.61	0.00	103.97	0.05
RY11	103.60	0.00	103.88	0.00	103.99	0.05
RY12	103.60	0.00	103.88	0.00	104.01	0.05
RY13	103.60	0.00	103.88	0.00	103.97	0.05
RY14	103.60	0.00	103.88	0.00	103.97	0.05

NOTE: THE POSITION OF ALL POLE LINES, CONDUITS, WATERMANS, SEWERS AND OTHER UNDERGROUND AND OVERGROUND UTILITIES AND STRUCTURES IS NOT NECESSARILY SHOWN ON THE CONTRACT DRAWINGS, AND WHERE SHOWN, THE ACCURACY OF THE POSITION OF SUCH UTILITIES AND STRUCTURES IS NOT GUARANTEED. BEFORE STARTING WORK, DETERMINE THE EXACT LOCATION OF ALL SUCH UTILITIES AND STRUCTURES AND ASSUME ALL LIABILITY FOR DAMAGE TO THEM.

PHOENIX HOMES
SINCE 1988
18A BENTLEY AVE
OTTAWA, ON, K2E 6T8

SCALE
1:300
0 3 6 9 12

FOR REVIEW ONLY
LRW
MAB
LPA
MAB
MAB
MAB

NOVATECH
Engineers, Planners & Landscape Architects
Suite 200, 240 Michael Copland Drive
Ottawa, Ontario, Canada K2M 1P6
Telephone: (613) 254-9643
Facsimile: (613) 254-5867
Website: www.novatech-eng.com

CITY OF OTTAWA
3400 WOODROFFE AVENUE
GRADING PLAN
PROJECT NO: 124147
REV # 2
124147-GR

D07-12-25-0158 & D02-02-25-0090
PLAN #19422

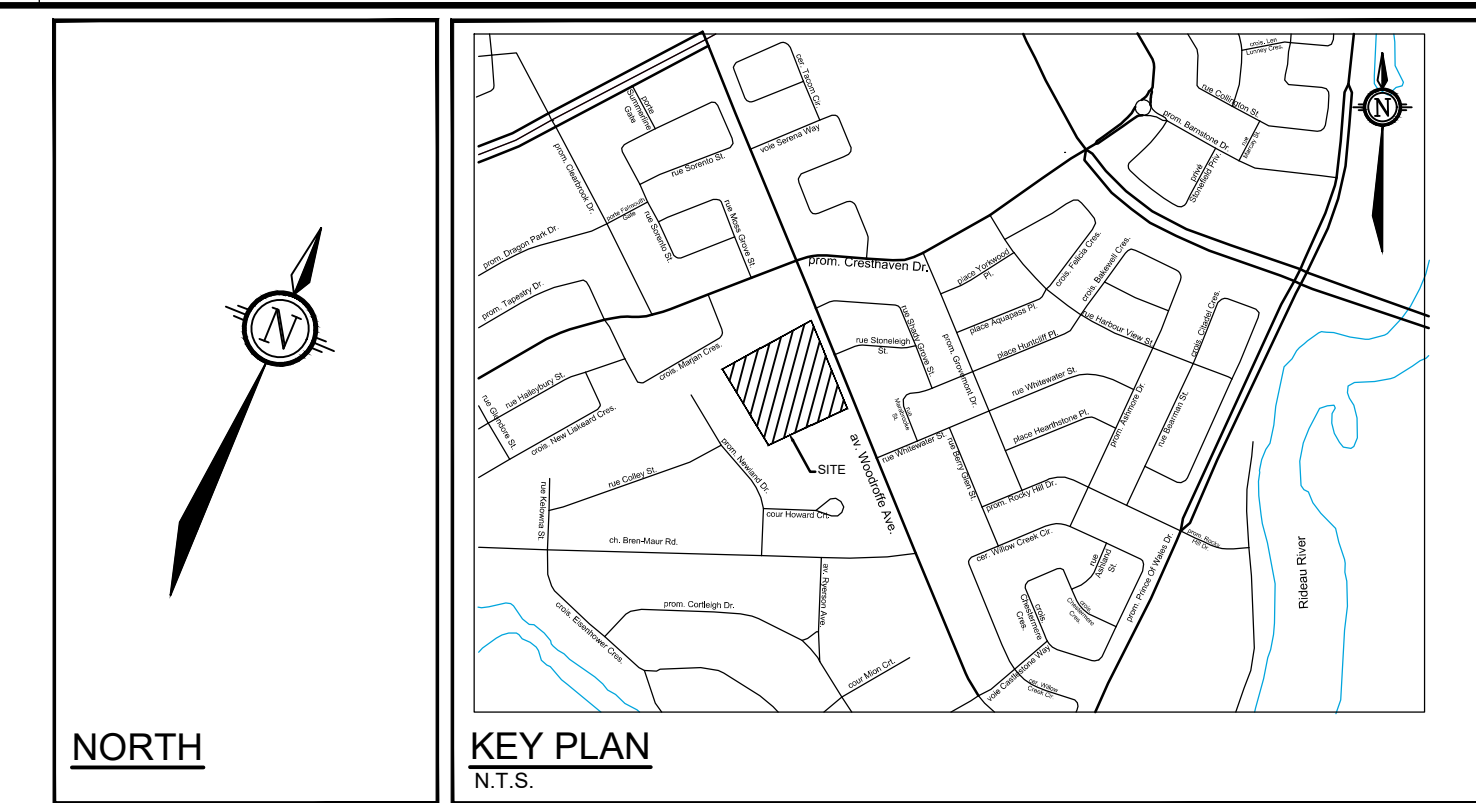

- LEGEND**
- PROPOSED SANITARY MANHOLE & SEWER WITH DIRECTION OF FLOW
 - PROPOSED STORM MANHOLE & SEWER WITH DIRECTION OF FLOW
 - PROPOSED STORM CATCHBASIN MANHOLE & SEWER WITH DIRECTION OF FLOW
 - PROPOSED WATERMAIN AND DIAMETER
 - PROPOSED HYDRANT CW VALVE & LEAD
 - PROPOSED WATERMAIN CAP
 - PROPOSED WATERMAIN BEND AND THRUST BLOCK
 - PROPOSED CATCH BASIN
 - PROPOSED REAR YARD CATCH BASIN
 - PROPOSED SERVICE LATERALS (WATER & SANITARY)
 - EXISTING STORM MANHOLE, SEWER & FLOW DIRECTION
 - EXISTING SAN MANHOLE, SEWER & FLOW DIRECTION
 - EXISTING CATCH BASIN
 - R-3 VALVE CHAMBER(W12) WITH FIRE LINE METER(W32-1)

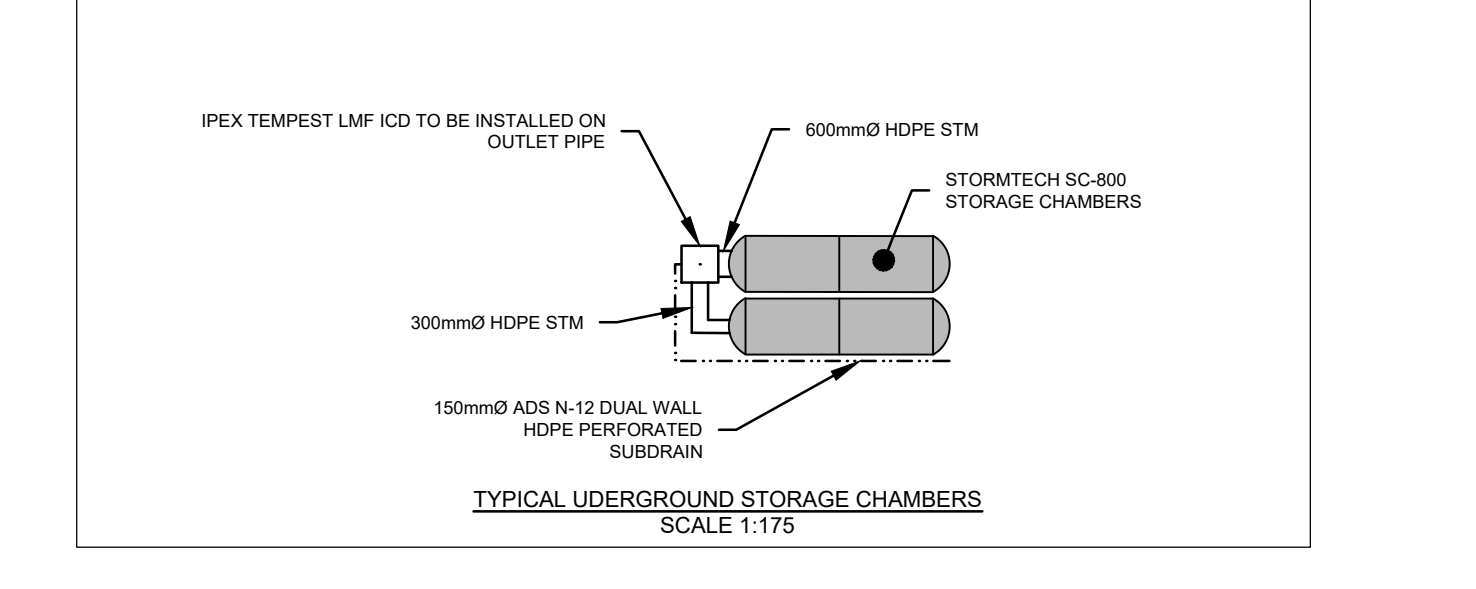
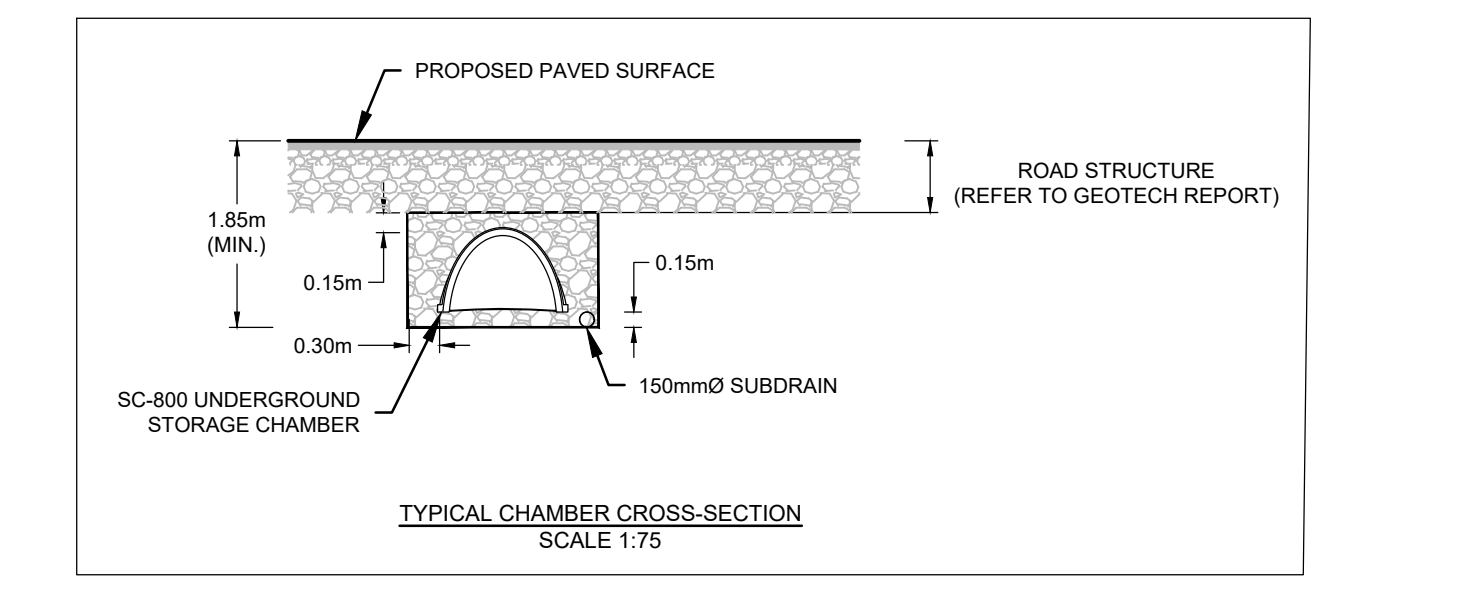

NOTE:
 THE POSITION OF ALL POLE LINES, CONDUITS, WATERMANS, SEWERS AND OTHER UNDERGROUND AND OVERGROUND UTILITIES AND STRUCTURES IS NOT NECESSARILY SHOWN ON THE CONTRACT DRAWINGS, AND WHERE SHOWN, THE ACCURACY OF THE POSITION OF SUCH UTILITIES AND STRUCTURES IS NOT GUARANTEED. BEFORE STARTING WORK, DETERMINE THE EXACT LOCATION OF ALL SUCH UTILITIES AND STRUCTURES AND ASSUME ALL LIABILITY FOR DAMAGE TO THEM.



No.	REVISION	DATE	BY
2	ADDRESS CITY COMMENTS	APR 14/28	MAB
1	SITE PLAN APPLICATION	NOV 5/25	MAB

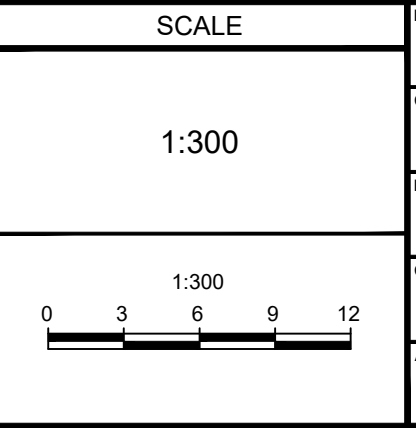

FOR REVIEW ONLY

PROFESSIONAL ENGINEER
 L.R. WILSON
 10180055
 PROVINCE OF ONTARIO

PROFESSIONAL DESIGNER
 M.A. BISSETT
 2026.04.14
 PROVINCE OF ONTARIO

NOVATECH
 Engineers, Planners & Landscape Architects
 Suite 200, 240 Michael Cowpland Drive
 Ottawa, Ontario, Canada K2M 1P6
 Telephone: (613) 254-9643
 Facsimile: (613) 254-5867
 Website: www.novatech-eng.com

CITY OF OTTAWA
 3400 WOODROFFE AVENUE

SERVICING PLAN

PROJECT NO: 124147
 REV: 2
 DRAWING NO: 124147-GP

D07-12-25-01568 & D02-02-25-0090

GENERAL NOTES & INSTRUCTIONS:

- THE ORIGINAL GROUND ELEVATIONS, SERVICING, UTILITY, AND SURVEY INFORMATION SHOW ON THIS PLAN ARE SUPPLIED FOR INFORMATION PURPOSES ONLY. THE CONTRACTOR IS RESPONSIBLE TO VERIFY THE ACCURACY OF ALL INFORMATION OBTAINED FROM THIS PLAN.
- THE CONTRACTOR SHALL CONFIRM THE LOCATION OF ALL EXISTING UTILITIES WITHIN THE SITE AND ADJACENT WORK AREAS. THE CONTRACTOR IS RESPONSIBLE FOR THE PROTECTION OF ALL EXISTING UTILITIES, INCLUDING THE REPAIR OR REPLACEMENT OF ANY SERVICES OR UTILITIES DISTURBED DURING CONSTRUCTION. ALL TO THE SATISFACTION OF THE ENGINEER.
- PRIOR TO CONSTRUCTION START, THE CONTRACTOR SHALL PROVIDE PROOF OF INSURANCE TO THE ENGINEER IN THE AMOUNT AND TYPE OUTLINED IN THE CONTRACT AGREEMENT. THE INSURANCE POLICY SHALL NAME THE OWNER, ENGINEER, AND MUNICIPALITY AS CO-INSURED.
- COORDINATE AND SCHEDULE ALL WORK WITH OTHER TRADES AND CONTRACTORS.
- CONFIRM DIMENSIONS AND LAYOUT INFORMATION BEFORE CONSTRUCTION START, AND REPORT ANY DISCREPANCIES TO THE ENGINEER.
- ELEVATIONS ARE GEODETIC AND UTILIZE METRIC UNITS. DIMENSIONS ARE IN METERS UNLESS OTHERWISE STATED.
- OBTAIN AND PAY FOR ALL NECESSARY PERMITS AND APPROVALS BEFORE CONSTRUCTION START.
- ALL WORK AND MATERIALS SHALL CONFORM TO THE LATEST MUNICIPAL STANDARDS AND SPECIFICATIONS, AND ONTARIO PROVINCIAL STANDARD DRAWINGS (OPSD) AND SPECIFICATIONS (OPSS).
- RESTORE ALL DISTURBED AREAS TO EXISTING CONDITIONS OR BETTER, TO THE SATISFACTION OF THE ENGINEER.
- ALL WORK SHALL BE COMPLETED IN ACCORDANCE WITH THE "OCCUPATIONAL HEALTH AND SAFETY ACT" AND REGULATIONS FOR CONSTRUCTION PROJECTS. THE GENERAL CONTRACTOR IS DEEMED TO BE THE CONSTRUCTOR AS DEFINED IN THE ACT.
- CONSTRUCTION SIGNAGE MUST CONFORM TO THE CURRENT MTO MANUAL OF UNIFORM TRAFFIC CONTROL DEVICES.

REPORTS & REFERENCE PLANS:

- REFER TO SITE PLAN AND ARCHITECTURAL DRAWINGS FOR BUILDING LAYOUT AND DETAILS.
- REFER TO LANDSCAPE ARCHITECTURE PLANS FOR HARDSCAPE FEATURES AND PLANTING INFORMATION.
- REFER TO THE SERVICING BRIEF NOVATECH FILE: 124147 REF: R-2025-80 FOR SERVICING DESIGN DETAILS.
- REFER TO GEOTECHNICAL REPORT PG7287-1 PREPARED BY PATERSON GROUP FOR SUBSURFACE CONDITIONS, CONSTRUCTION RECOMMENDATIONS, AND GEOTECHNICAL INSPECTION REQUIREMENTS. THE GEOTECHNICAL CONSULTANT SHALL REVIEW SITE CONDITIONS.

EROSION AND SEDIMENT CONTROL NOTES:

- ALL EROSION AND SEDIMENT CONTROLS ARE TO BE INSTALLED TO THE SATISFACTION OF THE ENGINEER, THE MUNICIPALITY AND THE CONSERVATION AUTHORITY. THEY ARE TO BE APPROPRIATE TO THE SITE CONDITIONS, PRIOR TO UNDERTAKING ANY SITE ALTERATIONS (FILLING, GRADING, REMOVAL OF VEGETATION, ETC.) AND DURING ALL PHASES OF SITE PREPARATION AND CONSTRUCTION. THESE PRACTICES ARE TO BE IMPLEMENTED IN ACCORDANCE WITH THE CURRENT BEST MANAGEMENT PRACTICES FOR EROSION AND SEDIMENT CONTROL AND SHOULD INCLUDE AS A MINIMUM THOSE MEASURES INDICATED ON THE PLAN.
 - TO PREVENT SURFACE EROSION FROM ENTERING THE DITCH OR STORM SYSTEM DURING CONSTRUCTION, SILT SACKS WILL BE PLACED UNDER GRATES OF ALL PROPOSED AND EXISTING CATCHBASINS AND STRUCTURES. A LIGHT DUTY SILT FENCE BARRIER WILL ALSO BE INSTALLED IN SELECTED LOCATIONS SHOWN ON THIS PLAN, AND STRAW BALE BARRIERS WILL BE INSTALLED WITHIN THE OUTLET DITCHES. THESE CONTROL MEASURES WILL REMAIN IN PLACE UNTIL VEGETATION HAS BEEN ESTABLISHED AND CONSTRUCTION COMPLETE.
 - THE SEDIMENT CONTROL MEASURES SHALL ONLY BE REMOVED WHEN, IN THE OPINION OF THE ENGINEER, THE MEASURES ARE NO LONGER REQUIRED. NO CONTROL MEASURES MAY BE PERMANENTLY REMOVED WITHOUT PRIOR AUTHORIZATION FROM THE ENGINEER.
 - THE CONTRACTOR SHALL IMMEDIATELY REPORT TO THE ENGINEER ANY ACCIDENTAL DISCHARGES OF SEDIMENT MATERIAL INTO ANY DITCH OR STORM SEWER SYSTEM. APPROPRIATE RESPONSE MEASURES, INCLUDING ANY REPAIRS TO EXISTING CONTROL MEASURES OR THE IMPLEMENTATION OF ADDITIONAL CONTROL MEASURES, SHALL BE CARRIED OUT BY THE CONTRACTOR WITHOUT DELAY.
 - THE CONTRACTOR ACKNOWLEDGES THAT FAILURE TO IMPLEMENT EROSION AND SEDIMENT CONTROL MEASURES MAY BE SUBJECT TO PENALTIES IMPOSED BY ANY APPLICABLE REGULATORY AGENCY.
 - THE CONTRACTOR SHALL ENSURE PROPER DUST CONTROL IS PROVIDED WITH THE APPLICATION OF WATER (AND IF REQUIRED, CALCIUM CHLORIDE) DURING DRY PERIODS.
- REMOVALS NOTES:**
- THE CONTRACTOR SHALL PROTECT ALL SURVEY MONUMENTS.
 - REMOVAL OF ALL ABOVE GROUND TRAFFIC PLANT AND STREET LIGHTING TO BE DONE BY OTHERS. CONTRACTOR SHALL PROTECT AND MAINTAIN EXISTING STREET LIGHTING, HYDRO POLES AND OVERHEAD LINES DURING CONSTRUCTION.
 - ALL BELL AND HYDRO OTTAWA MAINTENANCE HOLE ADJUSTMENTS SHALL BE PERFORMED BY AN APPROVED CONTRACTOR ONLY.
 - ALL TOPSOIL AND ANY SOFT, WET OR DELETERIOUS MATERIAL SHALL BE REMOVED FROM IMPROVED AREAS UNLESS OTHERWISE DIRECTED BY THE ENGINEER.
 - FORESTRY TO BE CONTACTED PRIOR TO ANY SELECTIVE PRUNING OR REMOVALS WITHIN THE AREAS OF TRESS SURROUNDING THE TRANS CANADA TRAIL AND TREES THAT ARE TO REMAIN ARE TO HAVE PROPER TREE PROTECTION FENCING.

STORM SEWERS:

- CONTRACTOR SHALL SUPPLY AND INSTALL ALL SEWERS AND APPURTENANCES IN ACCORDANCE WITH CURRENT MUNICIPAL STANDARDS AND SPECIFICATIONS (APPLIES TO STORM AND SANITARY SEWERS).
- REINFORCED CONCRETE STORM SEWER PIPES SHALL BE IN ACCORDANCE WITH CSA A257.2. NON-REINFORCED CONCRETE STORM SEWER PIPES SHALL BE IN ACCORDANCE WITH WITH CSA A257.1. PIPE SHALL BE JOINTED WITH STANDARD RUBBERIZED GASKETS PER CSA A257.3. LATEST AMENDMENT APPLIES TO ALL OF THE ABOVE ITEMS.
- STORM SEWER TRENCHING SHALL BE IN ACCORDANCE WITH OTTAWA DETAIL S6 AND S7.
- PIPE BEDDING, COVER AND BACKFILL TO BE CONSTRUCTED IN ACCORDANCE WITH OPSD 802 010802 013 FOR FLEXIBLE PIPE, AND 802.031802.033 FOR RIGID PIPE. PIPE BEDDING SHALL BE CLASS "B", UNLESS OTHERWISE NOTED, AND SHALL CONSIST OF 150mm GRANULAR "A" (300mm IN ROCK) COMPACTED TO AT LEAST 95% OF THE STANDARD PROCTOR MAXIMUM DRY DENSITY.
- PVC STORM SEWERS SHALL BE SDR35 APPROVED PER CSA B182.2, UNLESS OTHERWISE NOTED.
- STORM LATERALS TO BE 150mmØ WHITE PVC SDR35 WITH A 1.0% GRADIENT (MIN). CONSTRUCT SERVICES TO WITHIN 1.0m OF THE BUILDING FACE AND CAP; MARK WITH A WOODEN 50mm x 100mm STAKE PAINTED GREEN THAT EXTENDS 1.0m ABOVE GROUND.
- SERVICE CONNECTIONS TO SEWER MAIN IN ACCORDANCE WITH OTTAWA DETAIL S11 OR S11.1 AS APPROPRIATE.
- STORM MANHOLE FRAME AND COVER SHALL BE PER OTTAWA DETAIL S24.1 AND S25.
- CATCH BASINS IN ACCORDANCE WITH OTTAWA DETAIL S2 (INSTALLATION OF CATCH BASIN WITH CURB BARRIER) AND OPSD 705 010. FRAME AND GRATE PER OTTAWA DETAIL S19 FOR BOTH ROADWAY AND REAR YARD STRUCTURES.
- CATCH BASIN LEADS SHALL BE 200mmØ WITH A 1.0% (MIN) SLOPE (UNLESS OTHERWISE SPECIFIED)
- CATCH BASINS AND CBMH STRUCTURES TO HAVE 600mm DEEP SUMPS.
- CONTRACTOR TO ENSURE CATCH BASINS ARE INSTALLED AT LOW POINT.
- MINIMUM DIAMETER FOR REAR YARD PERFORATED PIPE IS 250mm, PER OTTAWA DETAIL S29.
- ROOF DRAINS SHALL OUTLET TO LANDSCAPED AREAS (WHERE INDICATED).
- CCTV ALL STORM SEWERS 250mm OR GREATER PRIOR TO PLACEMENT OF ASPHALT BASE COURSE.

SANITARY SEWERS:

- SANITARY SEWERS SHALL BE PVC SDR35, IPEX "RING-TITE" (OR EQUIVALENT), PER CSA B182.2.
- SANITARY SEWER TRENCH PER OTTAWA DETAIL S6 AND S7 WITH A CLASS "B" BEDDING.
- SANITARY LATERALS TO BE 150mmØ (TERRA FLATS - 12 UNITS) AND 135mmØ (TOWN HOMES), NON-WHITE PVC SDR35, IPEX "RING-TITE" (OR EQUIVALENT) WITH A 1.0% GRADIENT (2.0% PREFERRED). CONSTRUCT SERVICES TO WITHIN 1.0m OF THE BUILDING FACE AND CAP; MARK WITH A WOODEN 50mm x 100mm STAKE PAINTED RED THAT EXTENDS 1.0m ABOVE THE GROUND. LATERALS IN GENERAL CONFORMANCE WITH DETAIL S11.3, SECTION A-A.
- BACK WATER VALVES SHALL BE INSTALLED ON ALL SANITARY SERVICES PER OTTAWA DETAIL S14.1 OR S14.2.
- SANITARY MANHOLE FRAME AND COVERS PER OTTAWA DETAIL S24 AND S25.
- CONTRACTOR TO PERFORM LEAKAGE TEST ON SANITARY SEWER IN ACCORDANCE WITH OPSS 410.07.16, 410.07.16.04 AND 407.07.24.
- CCTV ALL SANITARY SEWERS 200mm OR GREATER PRIOR TO PLACEMENT OF ASPHALT BASE COURSE.

WATER SUPPLY:

- PVC WATERMAIN SHALL BE EQUAL TO AWWA C-900 CLASS 150, SDR18 OR APPROVED EQUAL AND SUPPLIED IN ACCORDANCE WITH MATERIAL SPECIFICATION MW-18.1.
- WATERMAIN TRENCH AND BEDDING IN ACCORDANCE WITH OTTAWA DETAIL W17.
- PVC FITTINGS SHALL BE INSTALLED WITH A TRACER WIRE IN ACCORDANCE WITH OTTAWA DETAIL W36.
- THE WATER SERVICES MATERIAL SHALL BE PEX-A (SEE SERVICING PLAN FOR SIZING). WATER SERVICE SHALL BE MARKED WITH A 50mm x 100mm STAKE PAINTED BLUE.
- CATHODIC PROTECTION IS REQUIRED ON ALL METALLIC FITTINGS PER OTTAWA DETAIL W40 AND W42.
- INSULATION FOR WATERMAIN CROSSING OVER AND BELOW SEWERS IN ACCORDANCE WITH OTTAWA DETAIL W25.2 AND W25 (APPLICABLE IF WATERMAIN COVER IS LESS THAN 2.4m).
- INSULATE WATER SERVICES PER OTTAWA DETAIL W23, WHEN SEPARATION BETWEEN SERVICE AND MANHOLE IS LESS THAN 1.2m.
- MINIMUM VERTICAL CLEARANCE BETWEEN WATERMAIN AND SEWER OR UTILITY IS 0.50m WHEN CROSSING OVER A PIPE (W25.2), AND 0.50m WHEN CROSSING UNDER A PIPE (W25). THE CONTRACTOR IS RESPONSIBLE TO PROVIDE ADEQUATE SUPPORT TO THE EXISTING INFRASTRUCTURE.
- WATER SERVICES CROSSING SEWERS SHALL BE INSTALLED PER OTTAWA DETAIL W38.

GRADING AND PAVEMENT NOTES:

- ALL TOPSOIL, ORGANIC OR DELETERIOUS MATERIAL MUST BE ENTIRELY REMOVED FROM BENEATH THE PROPOSED HARD SURFACE (i.e. PAVEMENT, CURB, SIDEWALK, ETC.) AREAS AS DIRECTED BY THE SITE ENGINEER OR GEOTECHNICAL ENGINEER.
- EXPOSED SUBGRADES IN PROPOSED PAVED AREAS SHOULD BE HEAVILY PROOF ROLLED WITH A LARGE (10 TON) VIBRATORY STEEL DRUM ROLLER UNDER DRY CONDITIONS AND INSPECTED BY THE GEOTECHNICAL ENGINEER PRIOR TO THE PLACEMENT OF GRANULARS.
- ANY SOFT AREAS EVIDENT FROM THE PROOF ROLLING SHOULD BE SUB-EXCAVATED AND REPLACED WITH SUITABLE MATERIAL THAT IS FROST COMPATIBLE WITH THE EXISTING SOILS AS RECOMMENDED BY THE GEOTECHNICAL ENGINEER.
- REFER TO GEOTECHNICAL REPORT PG7287-1 PREPARED BY PATERSON GROUP FOR BACKFILL AND COMPACTION RECOMMENDATIONS.
- PRIOR TO PLACEMENT OF TOP/LIFT, THE CONTRACTOR SHALL ADJUST ALL STRUCTURES TO FINAL GRADE PER CITY OF OTTAWA STANDARDS.
- MINIMUM OF 2% GRADE FOR ALL GRASS AREAS UNLESS OTHERWISE NOTED.
- MAXIMUM TERRACING GRADE TO BE 3:1 UNLESS OTHERWISE NOTED.
- ALL GRADING BY CURBS ARE EDGE OF PAVEMENT GRADES UNLESS OTHERWISE INDICATED.
- ALL CURBS SHALL BE BARRIER CURB UNLESS OTHERWISE NOTED AND CONSTRUCTED PER CITY OF OTTAWA STANDARD (SC1.1).
- REFER TO LANDSCAPE PLAN FOR PLANTING AND OTHER LANDSCAPE FEATURE DETAILS.

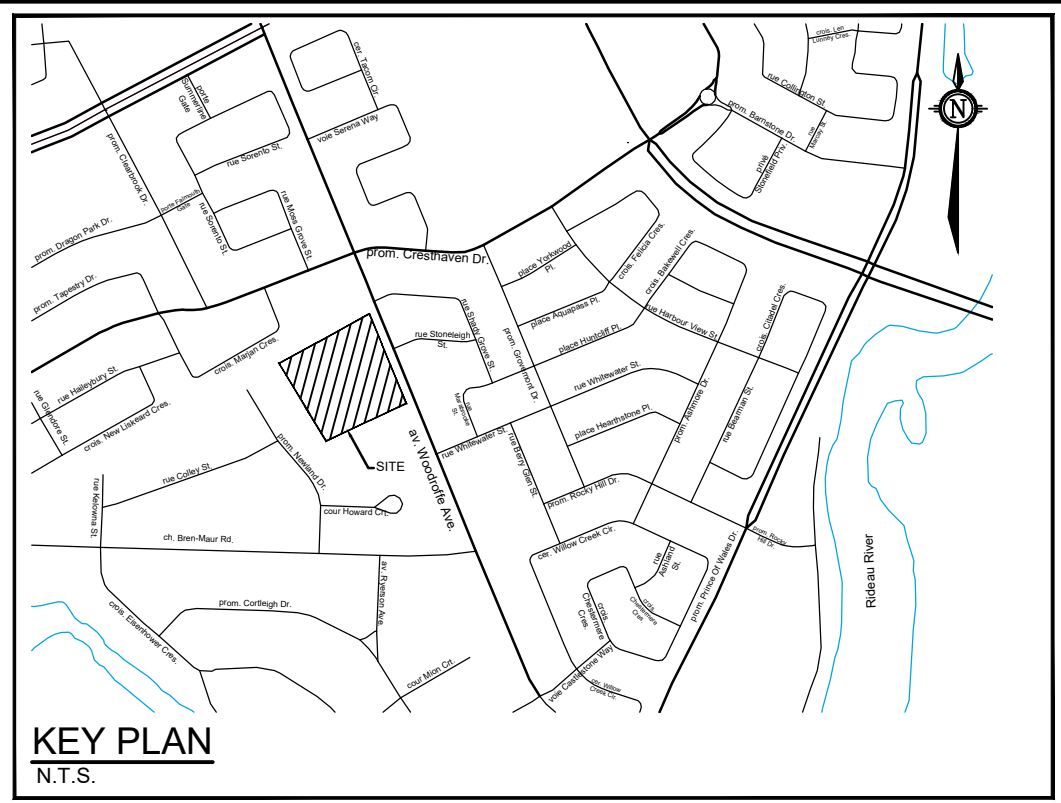

STATION	FIG ELEVATION	TOP OF WATERMAIN	DESCRIPTION
10+000.00	102.02	99.62	TEE
10+004.23	102.12	99.72	45° V-BEND
10+004.87	102.10	100.33	45° V-BEND
10+007.06	102.02	100.33	45° V-BEND
10+007.66	102.00	99.60	45° V-BEND
10+008.12	101.97	99.57	22.5° H-BEND
10+014.69	102.02	99.62	22.5° H-BEND
10+017.19	102.07	99.67	PL
10+025.00	102.40	100.00	-
10+030.62	102.68	100.29	R3-1
10+050.00	103.65	101.26	-
10+060.90	103.78	101.38	TEE

STATION	FIG ELEVATION	TOP OF WATERMAIN	DESCRIPTION
12+000.00	103.66	101.26	TEE
12+006.00	103.81	101.41	VBS
12+007.14	103.85	101.45	HYDRANT TEE
12+025.00	103.82	101.42	-
12+035.81	103.87	101.47	TEE
12+042.71	103.81	101.41	TEE
12+050.00	103.81	101.41	-
12+062.97	103.83	101.43	HYDRANT TEE
12+066.47	103.88	101.48	TEE
12+067.95	103.91	101.51	45° H-BEND
12+070.95	103.91	101.51	45° H-BEND
12+075.00	103.87	101.47	VBS
12+100.00	103.96	101.56	-
12+124.00	103.88	101.48	VBS
12+125.00	103.89	101.49	45° H-BEND
12+133.04	103.94	101.54	45° H-BEND
12+134.76	103.90	101.50	TEE
12+136.37	103.86	101.46	HYDRANT TEE
12+150.00	103.82	101.42	-
12+160.33	103.89	101.49	TEE
12+161.63	103.85	101.45	TEE
12+175.00	103.81	101.41	-
12+183.96	103.84	101.44	VB11
12+190.53	103.82	101.42	TEE

STATION	FIG ELEVATION	TOP OF WATERMAIN	DESCRIPTION
11+000.00	100.46	98.06	TEE
11+016.27	101.04	98.64	R3-2
11+025.00	103.35	100.95	-
11+050.00	104.27	101.87	-
11+058.25	104.48	101.58	45° H-BEND
11+060.61	104.28	101.58	45° H-BEND
11+075.00	103.84	101.44	-
11+082.96	103.80	101.40	TEE
11+095.47	103.83	101.43	HYDRANT TEE
11+100.00	103.87	101.47	-
11+102.53	103.82	101.42	TEE
11+106.53	103.74	101.34	VB12
11+108.00	103.71	101.31	TEE
11+125.00	103.73	101.33	-
11+141.36	103.80	101.30	VB4
11+147.36	103.78	101.38	TEE
11+150.00	103.74	101.34	-
11+153.36	103.69	101.39	VB3
11+164.57	103.66	101.26	TEE
11+170.20	103.77	101.37	VB6
11+175.00	103.82	101.42	-
11+182.95	103.68	101.28	TEE
11+189.86	103.65	101.25	REDUCER
11+195.35	103.71	101.31	45° H-BEND
11+198.39	103.69	101.29	45° V-BEND
11+198.69	103.70	101.38	45° V-BEND
11+199.44	103.72	102.00	45° V-BEND
11+199.74	103.73	101.33	45° V-BEND
11+200.00	103.74	101.34	-
11+207.08	103.99	101.59	45° H-BEND
11+225.53	104.07	101.67	CAP

STATION	FIG ELEVATION	TOP OF WATERMAIN	DESCRIPTION
13+000.00	103.87	101.47	TEE
13+006.00	103.85	101.45	VB7
13+025.00	103.84	101.44	-
13+050.00	103.81	101.41	-
13+055.86	103.86	103.86	VB10
13+061.86	103.85	101.45	TEE

STATION	FIG ELEVATION	TOP OF WATERMAIN	DESCRIPTION
1+000.00	103.68	101.28	TEE
1+000.49	103.69	101.29	45° V-BEND
1+001.58	103.68	102.44	45° V-BEND
1+005.23	103.70	102.45	45° V-BEND
1+006.31	103.71	101.31	45° V-BEND
1+007.25	103.72	101.32	22.5° H-BEND
1+012.00	103.97	101.57	22.5° H-BEND
1+025.00	104.12	101.72	-
1+027.11	104.10	101.70	CAP

STATION	FIG ELEVATION	TOP OF WATERMAIN	DESCRIPTION
7+000.00	103.81	101.41	TEE
7+003.30	103.75	101.35	22.5° H-BEND
7+008.52	103.78	101.38	22.5° H-BEND
7+025.00	104.18	101.78	-
7+027.62	104.13	101.73	CAP

STATION	FIG ELEVATION	TOP OF WATERMAIN	DESCRIPTION
2+000.00	103.71	101.31	TEE
2+001.34	103.70	101.30	22.5° H-BEND
2+007.80	103.70	101.30	22.5° H-BEND
2+025.00	104.17	101.77	-
2+027.03	104.15	101.75	CAP

STATION	FIG ELEVATION	TOP OF WATERMAIN	DESCRIPTION
3+001.34	103.72	101.32	45° V-BEND
3+001.70	103.70	101.30	45° V-BEND
3+005.36	103.62	101.84	45° V-BEND
3+005.89	103.63	101.23	45° V-BEND
3+007.80	103.70	101.30	22.5° H-BEND
3+025.00	104.11	101.71	-
3+027.03	104.09	101.69	CAP

STATION	FIG ELEVATION	TOP OF WATERMAIN	DESCRIPTION
4+000.00	103.89	101.49	TEE
4+025.00	104.16	101.76	-
4+028.80	104.14	101.74	CAP

STATION	FIG ELEVATION	TOP OF WATERMAIN	DESCRIPTION
6+000.00	103.88	101.48	TEE
6+025.00	103.79	101.39	-
6+029.67	103.79	101.39	CAP

MANHOLE ID	SIZE (mm)	T/G ELEV	INVERT	PIPE DIAMETER (mm)
110	1200Ø	102.35	E=98.30	E=200
111	1200Ø	103.86	N=99.68 S=99.68	N=200 S=200
112	1200Ø	103.69	S=99.91 SW=100.50 N=100.50	S=200 SW=200 N=200
113	1200Ø	103.79	NE=100.15 SW=100.33 SE=100.21 NW=100.56	NE=200 SW=200 SE=200 NW=200
114	1200Ø	103.93	NE=100.49 SE=100.56	NE=200 SE=200
115	1200Ø	103.77	SE=101.21	SE=200
116	1200Ø	104.10	SE=100.82	SE=200
117	1200Ø	103.64	N=99.85 S=99.86 E=100.48	N=200 S=200 E=200
118	1200Ø	104.13	W=100.74	W=200
119	1200Ø	103.86	N=99.91 SW=100.51 S=100.51	N=200 SW=200 S=200
120	1200Ø	103.87	NE=100.69 SW=100.69 NW=100.48	NE=200 NW=200 SW=200
121	1200Ø	103.94	NE=100.84 SE=101.14	NE=200 SE=200
122	1200Ø	103.78	NW=101.31	NW=200
123	1200Ø	103.87	NW=100.85	NW=200
124	1200Ø	103.67	N=100.56 S=101.00 E=100.96	N=200 S=200 E=200
125	1200Ø	104.08	W=101.22	W=200
126	1200Ø	104.21	E=101.45 N=101.25	N=200 E=200
127	1200Ø	103.97	W=101.70	W=200
128	1200Ø	103.73	S=100.62 N=101.00 E=101.00	S=200 N=200 E=200
129	1200Ø	104.08	W=101.26	W=200
130	1200Ø	103.98	S=101.12 NE=101.58	S=200 NE=200
131	1200Ø	104.04	SW=101.71	SW=200
132	1200Ø	104.13	NW=101.06	NW=200

MANHOLE ID	SIZE (mm)	T/G ELEV	INVERT	PIPE DIAMETER (mm)
211	1200Ø	102.29	E=450 W=450 S=250 NW=250	E=450 W=450 S=250 NW=250
212	1200Ø	103.87	N=99.68 E=99.62	E=450 N=450 S=450
213	1200Ø	103.74	S=99.76 N=101.39 SW=99.82	S=450 N=300 SW=375
214	1200Ø	103.92	NE=100.14 SE=100.22	NE=375 SE=300
215	1200Ø	103.83	N=99.79 SW=99.86 S=100.76	N=

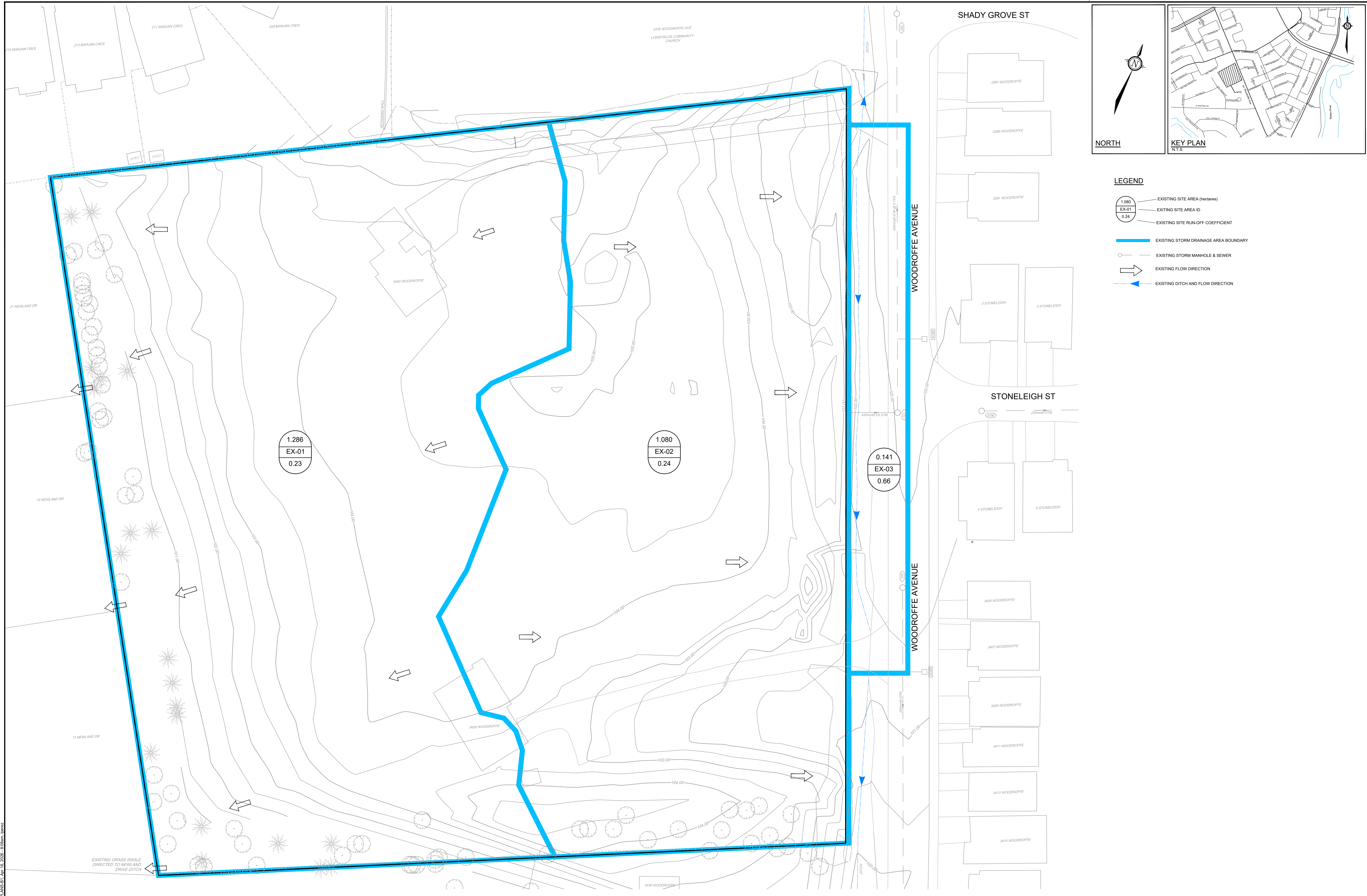

LEGEND

- 1.080 EXISTING SITE AREA (hectares)
- EX-01 EXISTING SITE AREA ID
- 0.24 EXISTING SITE RUN-OFF COEFFICIENT
- EXISTING STORM DRAINAGE AREA BOUNDARY
- EXISTING STORM MANHOLE & SEWER
- EXISTING FLOW DIRECTION
- EXISTING DITCH AND FLOW DIRECTION

KEY PLAN
N.T.S.

NORTH

NOTE:
THE POSITION OF ALL POLE LINES, CONDUITS, WATERMANS, SEWERS AND OTHER UNDERGROUND AND OVERGROUND UTILITIES AND STRUCTURES IS NOT NECESSARILY SHOWN ON THE CONTRACT DRAWINGS, AND WHERE SHOWN, THE ACCURACY OF THE POSITION OF SUCH UTILITIES AND STRUCTURES IS NOT GUARANTEED. BEFORE STARTING WORK, DETERMINE THE EXACT LOCATION OF ALL SUCH UTILITIES AND STRUCTURES AND ASSUME ALL LIABILITY FOR DAMAGE TO THEM.

PHOENIX HOMES
SINCE 1988
18A BENTLEY AVE
OTTAWA, ON, K2E 6T8

No.	REVISION	DATE	BY
2	ADDRESS CITY COMMENTS	APR 14/28	MAB
1	SITE PLAN APPLICATION	NOV 5/25	MAB

SCALE

1:300

0 3 6 9 12

FOR REVIEW ONLY

DESIGN: LRW
CHECKED: MAB
DRAWN: LPA
CHECKED: MAB
APPROVED: MAB

PROFESSIONAL ENGINEER
L.R. WILSON
10018055
PROVINCE OF ONTARIO

PROFESSIONAL ENGINEER
M.A. BISSETT
2026.04.14
PROVINCE OF ONTARIO

NOVATECH
Engineers, Planners & Landscape Architects
Suite 200, 240 Michael Cowpland Drive
Ottawa, Ontario, Canada K2M 1P6
Telephone: (613) 254-9643
Facsimile: (613) 254-5867
Website: www.novatech-eng.com

CITY OF OTTAWA
3400 WOODROFFE AVENUE

**PRE-DEVELOPMENT
STORM DRAINAGE AREA PLAN**

PROJECT No.	REV	REV #	DRAWING No.
124147		2	124147-STM1

C:\Users\124147\OneDrive\Documents\124147-STM1.dwg, PLANS-17, Apr 18, 2028 - 10:08am, bence

D07-12-25-0158 & D02-02-25-0090
PLAN #19422

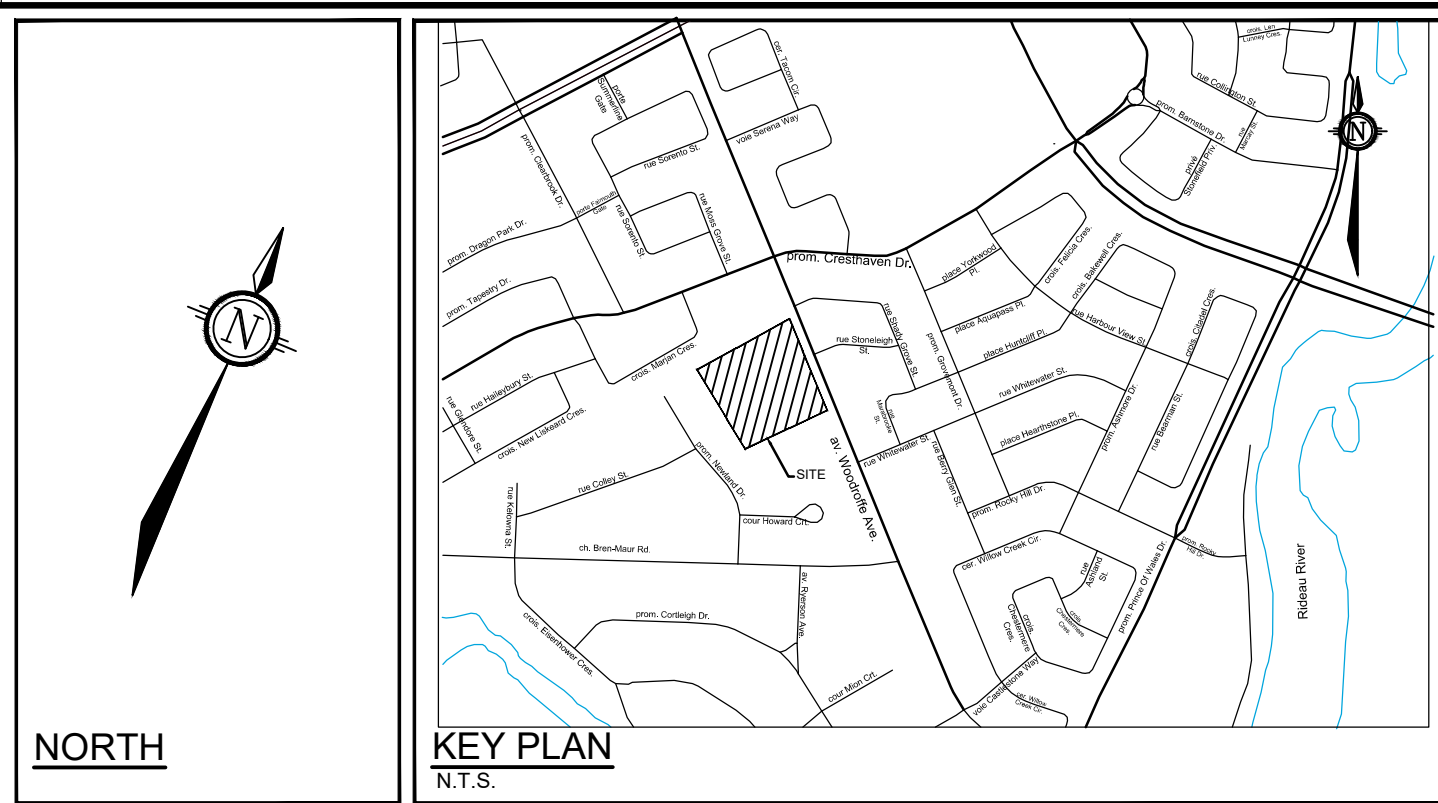
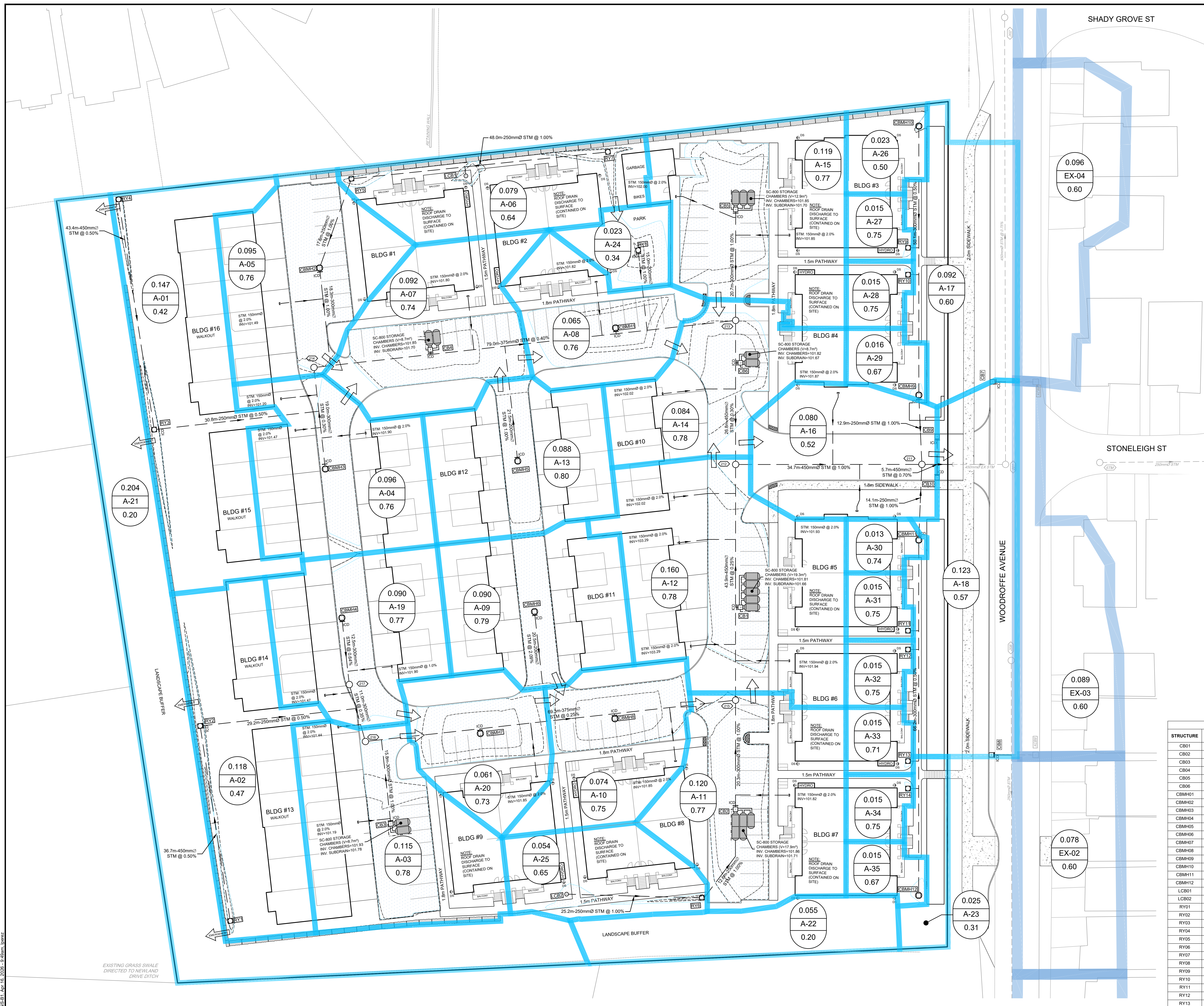

- LEGEND**
- 1.080 SITE AREA (hectares)
 - A-01 SITE AREA ID
 - 0.24 SITE RUN-OFF COEFFICIENT
 - STORM DRAINAGE AREA BOUNDARY
 - OFFSITE STORM DRAINAGE AREA BOUNDARY
 - EXISTING STORM MANHOLE & SEWER
 - ➔ MAJOR SYSTEM FLOW ROUTE
 - ➔ EMERGENCY FLOW ROUTE
 - PROPOSED STORM MANHOLE / SEWER AND FLOW DIRECTION
 - PROPOSED ROAD CATCHBASIN
 - REAR YARD CATCH BASIN
 - MAX STATIC PONDING LIMITS
 - 100-YR PONDING LIMITS
 - 100-YR +20% PONDING LIMITS

ICD TABLE

STRUCTURE ID	ICD TYPE	INVERT (m)	100-YR HEAD (m)	100-YR PEAK FLOW (L/s)
CB1	Tempest LMF	W=101.66	2.13	6.2
CB2	Tempest LMF	N=100.96	2.28	6.4
CB3	Tempest LMF	NW=100.89	2.94	7.3
CB4	Tempest LMF	SE=101.70	2.03	7.5
CB5	Tempest LMF	S=101.60	2.16	6.2
CB6	Tempest LMF	W=101.67	2.04	7.5
CB7	83mm	E=100.61	1.44	16.7
CB8	83mm	E=99.84	1.45	19.4
CB9	83mm	S=100.71	1.43	9.5
CB10	83mm	N=100.71	1.43	9.5
CBM1	Tempest LMF	SE=100.70	3.00	9.2
CBM2	Tempest LMF	SE=100.63	3.29	7.7
CBM3	Tempest LMF	NW=100.27	3.67	11.7
CBM4	Tempest LMF	SE=100.24	3.71	10.1
CBM5	Tempest LMF	NW=102.10	3.07	9.3
CBM6	Tempest LMF	SE=100.55	3.36	9.7
CBM7	Tempest LMF	NW=101.10	2.67	8.1
CBM8	Tempest LMF	NW=100.82	2.94	9.1
CBM9	Tempest LMF	SE=100.43	2.79	7.2
CBM11	Tempest LMF	N=100.44	3.16	7.6
RY2	83mm	NE=100.37	1.36	16.8
RY3	83mm	NE=100.42	1.32	16.6
RY8	Tempest LMF	SE=102.39	1.32	6.0

STRUCTURE	100 YEAR PONDING ELEVATION	100 YEAR PONDING DEPTH (m)	PONDING		MAX STATIC PONDING ELEVATION	MAX STATIC PONDING DEPTH (m)
			100 YEAR +20% PONDING ELEVATION	100 YEAR +20% PONDING DEPTH (m)		
CB01	103.79	0.28	103.84	0.33	103.83	0.32
CB02	103.80	0.24	103.86	0.30	103.86	0.30
CB03	103.83	0.20	103.87	0.24	103.93	0.30
CB04	103.73	0.18	103.87	0.32	103.88	0.33
CB05	103.76	0.21	103.81	0.26	103.85	0.30
CB06	103.69	0.17	103.77	0.25	103.82	0.30
CBM101	103.70	0.15	103.74	0.19	103.85	0.30
CBM102	103.92	0.29	103.94	0.31	103.93	0.30
CBM103	103.94	0.21	103.95	0.22	103.93	0.20
CBM104	103.95	0.21	103.96	0.22	103.94	0.20
CBM105	103.87	0.22	103.91	0.26	103.90	0.25
CBM106	103.91	0.26	103.93	0.28	103.91	0.26
CBM107	103.77	0.17	103.86	0.26	103.90	0.30
CBM108	103.76	0.19	103.85	0.28	103.87	0.30
CBM109	103.22	0.00	103.60	0.00	103.73	0.08
CBM110	103.23	0.00	103.61	0.11	103.58	0.08
CBM111	103.60	0.00	103.88	0.00	103.99	0.04
CBM112	103.60	0.00	103.88	0.10	103.83	0.05
LCB01	103.92	0.06	103.95	0.09	103.94	0.08
LCB02	103.80	0.00	103.86	0.00	104.05	0.07
RY01	101.73	0.21	101.81	0.29	101.79	0.27
RY02	101.73	0.21	101.81	0.29	101.77	0.25
RY03	101.73	0.29	101.77	0.33	101.75	0.31
RY04	101.73	0.23	101.77	0.27	101.72	0.22
RY05	103.92	0.06	103.95	0.09	103.95	0.09
RY06	103.80	0.08	103.86	0.14	103.96	0.24
RY07	103.92	0.10	103.95	0.13	103.95	0.13
RY08	103.82	0.03	103.87	0.08	103.94	0.15
RY09	103.22	0.00	103.61	0.00	104.00	0.05
RY10	103.22	0.00	103.61	0.00	103.97	0.05
RY11	103.60	0.00	103.88	0.00	103.99	0.05
RY12	103.60	0.00	103.88	0.00	104.01	0.05
RY13	103.60	0.00	103.88	0.00	103.97	0.05
RY14	103.60	0.00	103.88	0.00	103.97	0.05

NOTE: THE POSITION OF ALL POLE LINES, CONDUITS, WATERMANS, SEWERS AND OTHER UNDERGROUND AND OVERGROUND UTILITIES AND STRUCTURES IS NOT NECESSARILY SHOWN ON THE CONTRACT DRAWINGS, AND WHERE SHOWN, THE ACCURACY OF THE POSITION OF SUCH UTILITIES AND STRUCTURES IS NOT GUARANTEED. BEFORE STARTING WORK, DETERMINE THE EXACT LOCATION OF ALL SUCH UTILITIES AND STRUCTURES AND ASSUME ALL LIABILITY FOR DAMAGE TO THEM.

PHOENIX HOMES
SINCE 1988
18A BENTLEY AVE
OTTAWA, ON, K2E 6T8

SCALE
1:300
0 3 6 9 12

FOR REVIEW ONLY
 LRW
 MAB
 LPA
 MAB
 MAB
 MAB

NOVATECH
Engineers, Planners & Landscape Architects
Suite 200, 240 Michael Copland Drive
Ottawa, Ontario, Canada K2M 1P6
Telephone: (613) 254-9643
Facsimile: (613) 254-5867
Website: www.novatech-eng.com

CITY OF OTTAWA
3400 WOODROFFE AVENUE
POST-DEVELOPMENT
STORM DRAINAGE AREA PLAN

PROJECT NO: 124147
REV # 2
124147-STM2

D07-12-25-0158 & D02-02-25-0090 PLAN #19422

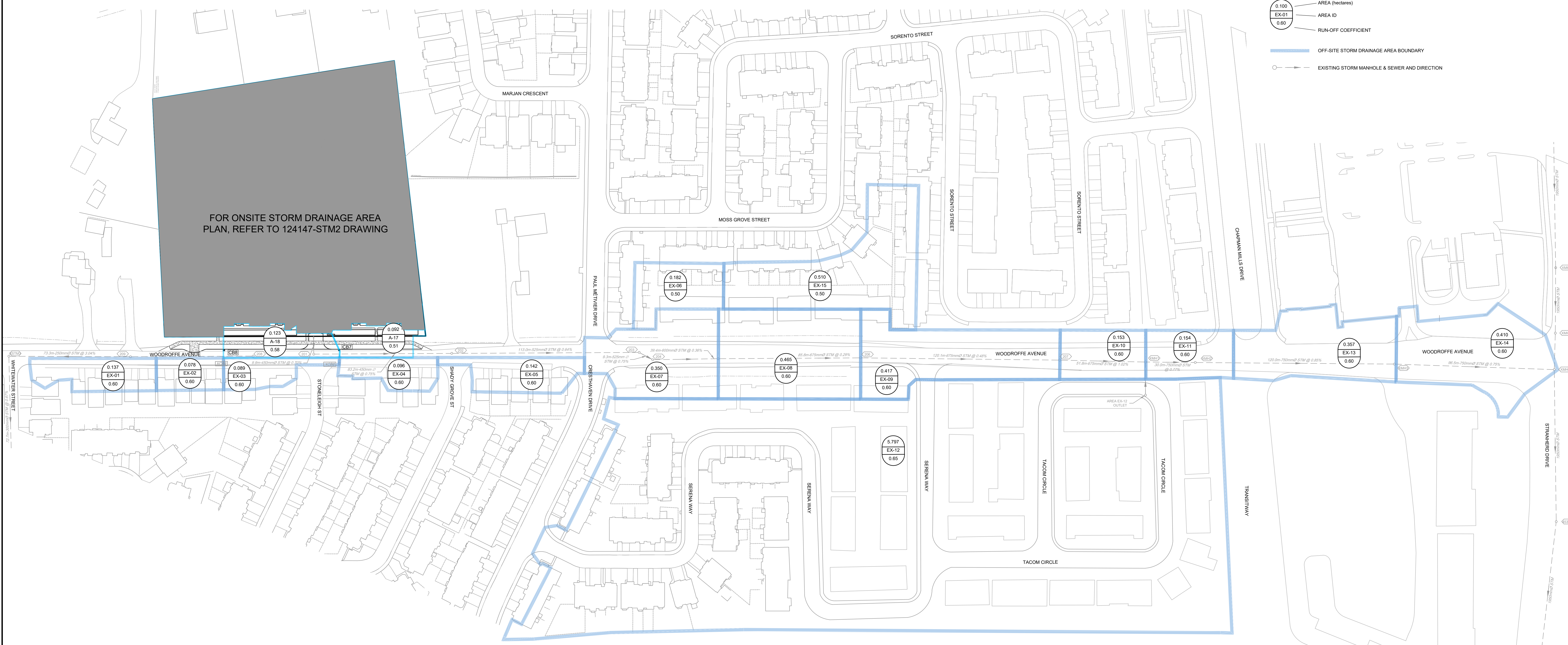
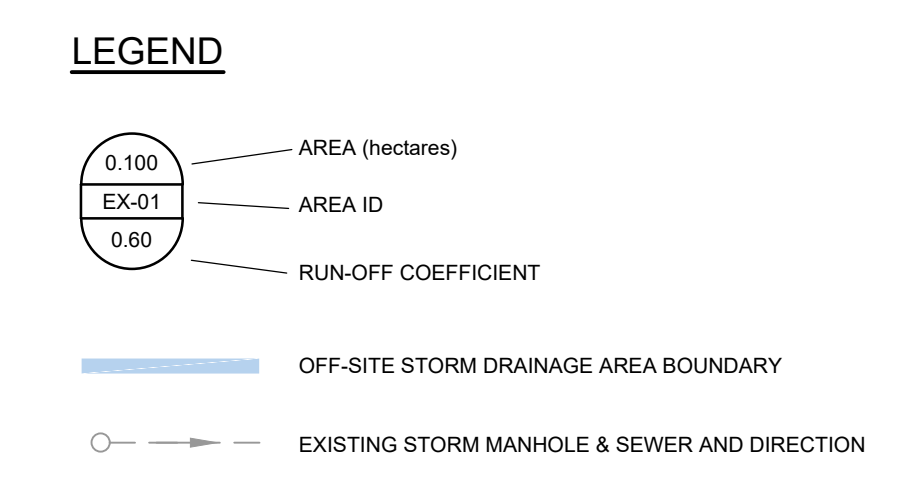
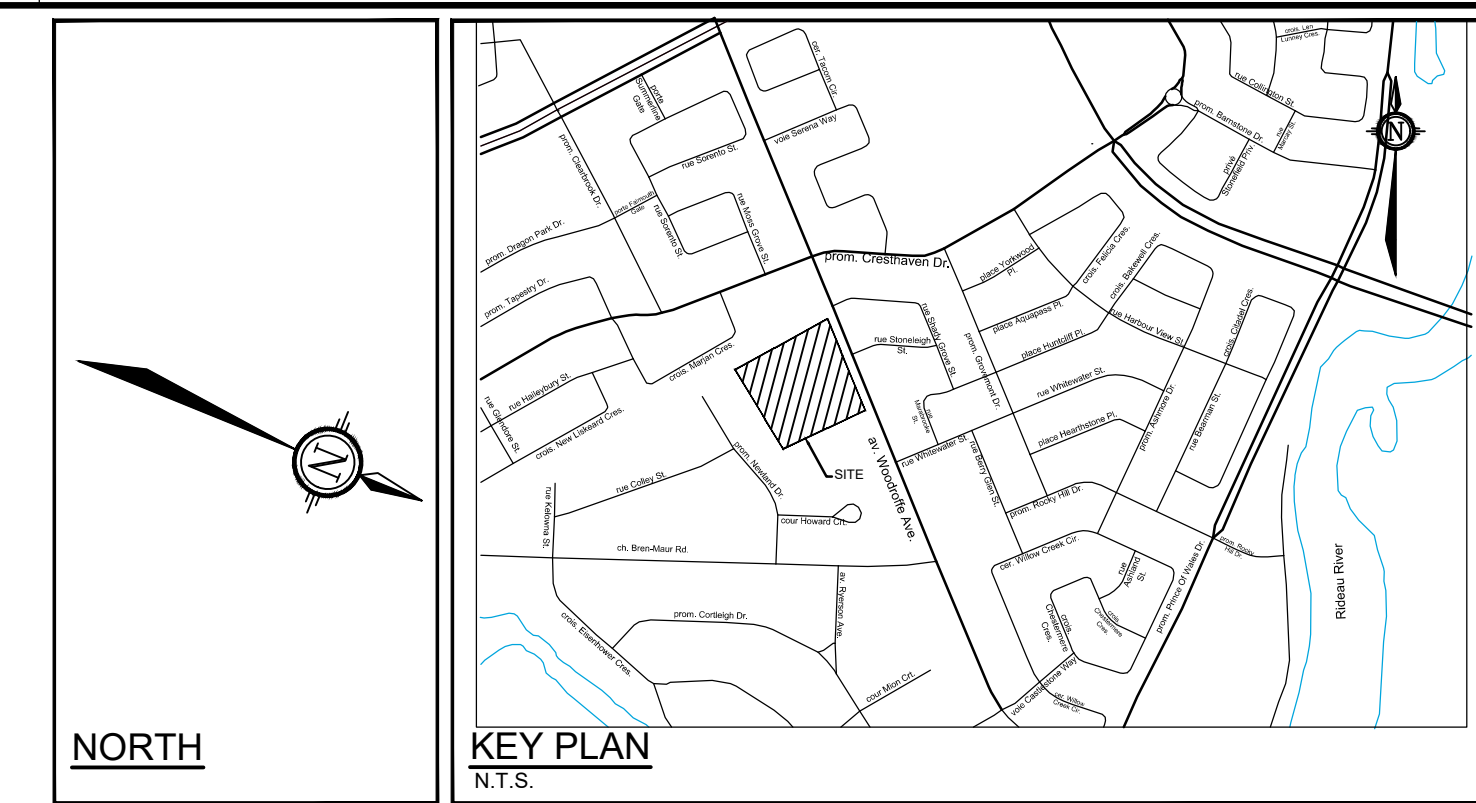

NOTE:
THE POSITION OF ALL POLE LINES, CONDUITS, WATERMANS, SEWERS AND OTHER UNDERGROUND AND OVERGROUND UTILITIES AND STRUCTURES IS NOT NECESSARILY SHOWN ON THE CONTRACT DRAWINGS, AND WHERE SHOWN, THE ACCURACY OF THE POSITION OF SUCH UTILITIES AND STRUCTURES IS NOT GUARANTEED. BEFORE STARTING WORK, DETERMINE THE EXACT LOCATION OF ALL SUCH UTILITIES AND STRUCTURES AND ASSUME ALL LIABILITY FOR DAMAGE TO THEM.



No.	REVISION	DATE	BY
1.	ADDRESS CITY COMMENTS	APR 14/26	MAB

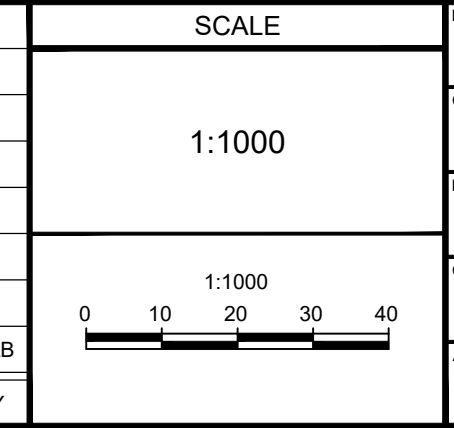

DESIGN	LRW
CHECKED	MAB
DRAWN	LPA
CHECKED	MAB
APPROVED	MAB

FOR REVIEW ONLY

REGISTERED PROFESSIONAL ENGINEER
L.R. WILSON
10160055
PROVINCE OF ONTARIO

REGISTERED PROFESSIONAL ENGINEER
M.A. BISSETT
2026.04.14
PROVINCE OF ONTARIO



CITY OF OTTAWA
3400 WOODROFFE AVENUE

OFF-SITE STORM DRAINAGE AREA PLAN

PROJECT No.	124147
REV	REV # 1
DRAWING No.	124147-STM3

C:\Users\124147\OneDrive\124147-STM3.dwg OFFSITE Apr 16 2025 9:46am, lpaeez

D07-12-25-0158 & D02-02-25-0090 PLAN #19422



NORTH

KEY PLAN
N.T.S.

- GRAVEL SHOULDER & DRIVEWAY REMOVAL
- CLEARING, GRUBBING & VEGETATION REMOVAL
- MUD MATS (50mm - 100mm GRANULAR B. TYPE II)
- REMOVAL OF CONCRETE AND ASPHALT SIDEWALKS AND CURBS, INCLUDING PAVERS (OF ALL TYPES)
- X** REMOVALS
- LIGHT DUTY SILT FENCE PER OPSD 219.110
- TERRAFIX SILTSACKS INSTALLED AT CATCH BASIN
- EXISTING CONTOUR AND ELEVATION
- STRAW BALE FLOW CHECK PER OPSD 219.180

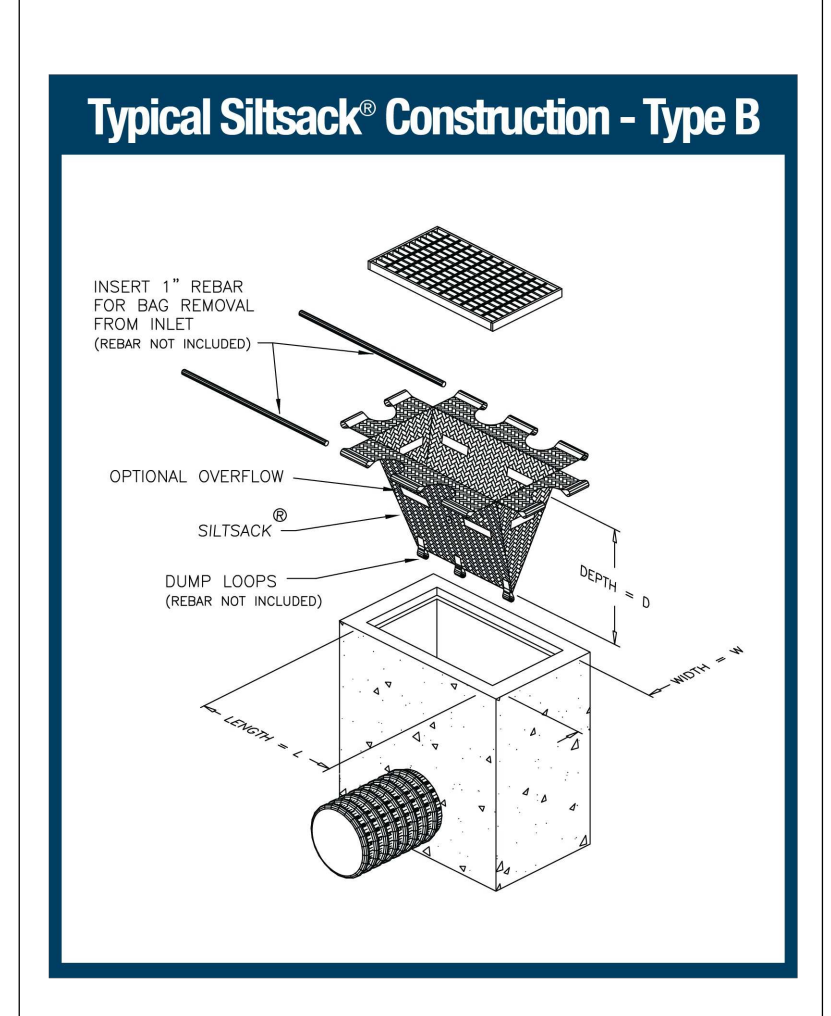

NOTE:
THE POSITION OF ALL POLE LINES, CONDUITS, WATERMANS, SEWERS AND OTHER UNDERGROUND AND OVERGROUND UTILITIES AND STRUCTURES IS NOT NECESSARILY SHOWN ON THE CONTRACT DRAWINGS, AND WHERE SHOWN, THE ACCURACY OF THE POSITION OF SUCH UTILITIES AND STRUCTURES IS NOT GUARANTEED. BEFORE STARTING WORK, DETERMINE THE EXACT LOCATION OF ALL SUCH UTILITIES AND STRUCTURES AND ASSUME ALL LIABILITY FOR DAMAGE TO THEM.

No.	REVISION	DATE	BY
2	ADDRESS CITY COMMENTS	APR 14/28	MAB
1	SITE PLAN APPLICATION	NOV 5/25	MAB

SCALE

1:300

FOR REVIEW ONLY

DESIGN	LRW
CHECKED	MAB
DRAWN	LPA
CHECKED	MAB
APPROVED	MAB

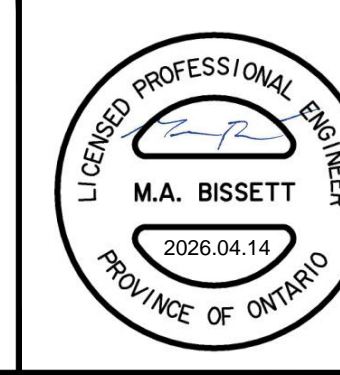

NOVATECH
Engineers, Planners & Landscape Architects
Suite 200, 240 Michael Cowpland Drive
Ottawa, Ontario, Canada K2M 1P6
Telephone: (613) 254-9643
Facsimile: (613) 254-5867
Website: www.novatech-eng.com

CITY OF OTTAWA
3400 WOODROFFE AVENUE

SITE REMOVALS, EROSION AND SEDIMENT CONTROL PLAN

PROJECT NO.	124147
REV	REV #2
DRAWING NO.	124147-ESC

C:\Users\124147\OneDrive\Documents\124147-ESC-Plan\PLANS\124147-ESC-Plan\124147-ESC-Plan.dwg, PLANS\124147-ESC-Plan\124147-ESC-Plan.dwg, Apr 15, 2028 - 3:29pm, bbenz

D07-12-25-0158 & D02-02-25-0090