

SITE SERVICING & STORM WATER MANAGEMENT REPORT 2025 OTHELLO AVENUE

Project No.: CCO-22-1241



Prepared for:

Osgoode Properties
1284 Wellington St W
Ottawa, ON K1Y 3A9

Prepared by:

Egis Canada Ltd.
750 Palladium, Suite 310
Kanata, ON
K2V 1C7

Revision 3: 2026/02/06

Table of Content

| | | |
|------------|--|-----------|
| 1.0 | PROJECT DESCRIPTION | 1 |
| 1.1 | Purpose..... | 1 |
| 1.2 | Site Description..... | 1 |
| 1.3 | Existing Conditions and Infrastructure..... | 2 |
| 1.4 | Proposed Development and Statistics..... | 2 |
| 1.5 | Approvals..... | 2 |
| 1.0 | BACKGROUND STUDIES, STANDARDS, AND REFERENCES | 3 |
| 1.1 | Background Reports / Reference Information..... | 3 |
| 1.2 | Applicable Guidelines and Standards..... | 3 |
| 1.2.1 | City of Ottawa:..... | 3 |
| 1.2.2 | Ministry of Environment, Conservation and Parks:..... | 3 |
| 1.2.3 | Other:..... | 3 |
| 2.0 | PRE-CONSULTATION SUMMARY | 4 |
| 3.0 | WATERMAIN | 5 |
| 3.1 | Existing Watermain..... | 5 |
| 3.2 | Proposed Watermain..... | 5 |
| 4.0 | SANITARY DESIGN | 9 |
| 4.1 | Existing Sanitary Sewer..... | 9 |
| 4.2 | Proposed Sanitary Sewer..... | 9 |
| 5.0 | STORM SEWER DESIGN | 11 |
| 5.1 | Existing Storm Sewers..... | 11 |
| 5.2 | Proposed Storm Sewers..... | 11 |
| 6.0 | PROPOSED STORMWATER MANAGEMENT | 12 |
| 6.1 | Design Criteria and Methodology..... | 12 |
| 6.2 | Runoff Calculations..... | 12 |

| | | |
|-----|--|-----------|
| 6.3 | Pre-Development Drainage..... | 13 |
| 6.4 | Post-Development Drainage Areas..... | 13 |
| 6.5 | Quantity Control..... | 14 |
| 6.6 | Quality Control..... | 15 |
| 7.0 | EROSION AND SEDIMENT CONTROL..... | 15 |
| 7.1 | Temporary Measures..... | 15 |
| 7.2 | Permanent Measures..... | 16 |
| 8.0 | SUMMARY | 16 |
| 9.0 | RECOMMENDATION | 17 |

APPENDIX A : LOCATION PLAN

APPENDIX B : BACKGROUND INFORMATION

APPENDIX C : WATERMAIN CALCULATIONS

APPENDIX D : SANITARY CALCULATIONS

APPENDIX E : STORMWATER CALCULATIONS

APPENDIX F : PRE-DEVELOPMENT DRAWING

APPENDIX G : POST-DEVELOPMENT DRAWING

APPENDIX H : CITY OF OTTAWA CHECKLIST

1.0 PROJECT DESCRIPTION

1.1 Purpose

Egis Canada Ltd. (Egis) has been retained by Osgoode Properties to prepare this Servicing and Stormwater Management Report in support of the Site Plan Control process for the proposed development at 2025 Othello Avenue within the City of Ottawa (City).

The main purpose of this report is to present a servicing design for the development in accordance with the recommendations and guidelines provided by the City and the Rideau Valley Conservation Authority (RVCA). This report will address the water, sanitary, and storm sewer servicing for the development, ensuring that existing and available services will adequately service the proposed development.

This report should be read in conjunction with the following drawings:

- REM – Removal and Erosion and Sediment Control Plan;
- C101 – Grading, Drainage and Sediment & Erosion Control Plan;
- C102 – Site Servicing Plan; and
- NOTES – Notes

1.2 Site Description

The property, herein referred to as the site, is located at 2025 Othello Avenue within the Alta Vista ward in the City. The site covers approximately 2.42 ha and is located at the intersection of Othello Avenue and Pleasant Park Road. The site is zoned for Arterial Mainstreet use (AM10). See Site Location Plan in Appendix A for more details.



Figure 1: Site Location

1.3 Existing Conditions and Infrastructure

The site is currently developed; two existing 9-storey apartment buildings with outdoor parking currently occupy the site. The site fronts onto Othello Avenue, St. Laurent Boulevard, and Pleasant Park Road with access to sanitary and storm sewers as well as water.

Sewer and watermain mapping collected from the City of Ottawa indicate that the following services exist across the property frontages within the adjacent municipal rights-of-way (ROW):

- St. Laurent Blvd
 - 300 mm diameter cast iron watermain;
 - 225 mm diameter and 375 mm diameter concrete sanitary sewer, tributary to the Green Creek Collector North; and
 - 374/450 mm diameter concrete storm sewer, tributary to the Ottawa River.
- Othello Avenue
 - 300 mm diameter cast iron watermain;
 - 225 mm diameter and 375 mm diameter concrete sanitary sewer, tributary to the Green Creek Collector North; and
 - 300 mm diameter concrete storm sewer, tributary to the Ottawa River.
- Pleasant Park Road
 - 300 mm diameter cast iron watermain;
 - 250/375 mm diameter sanitary concrete sanitary sewer, tributary to the Green Creek Collector North; and
 - 300 mm diameter concrete storm sewer, tributary to the Ottawa River.

1.4 Proposed Development and Statistics

The proposed development consists of 3 blocks of stacked townhouses. Entrances are located along Othello Avenue Street to the west and internally. Further details are available in the site plan provided by SRN Architects included in Appendix B.

1.5 Approvals

The proposed development is subject to the City site plan control approval process. Site plan control requires the City to review, provide concurrence and approve the engineering design package. Permits to construct can be requested once the City has issued a site plan agreement.

An Environmental Compliance Approval (ECA) through the Ministry of Environment, Conservation and Parks (MECP) may be required for the contemplated development as the property consists of two parcels of land. Further discussion with the MECP to determine if an ECA is required.

2.0 BACKGROUND STUDIES, STANDARDS, AND REFERENCES

2.1 Background Reports / Reference Information

Background studies have been completed for the proposed development, which include the City's as-built drawings, a topographical survey, and a geotechnical report.

As-built drawings of existing services, provided by the City of Ottawa Information Centre, within the vicinity of the proposed site were reviewed in order to identify infrastructure available to service the proposed development.

2.2 Applicable Guidelines and Standards

2.2.1 City of Ottawa:

- Ottawa Sewer Design Guidelines, City of Ottawa, SDG002, October 2012. (Ottawa Sewer Guidelines)
 - Technical Bulletin ISTB-2014-01 City of Ottawa, February 2014. (ISTB-2014-01)
 - Technical Bulletin PIEDTB-2016-01 City of Ottawa, September 2016. (PIEDTB-2016-01)
 - Technical Bulletin ISTB-2018-01 City of Ottawa, January 2018. (ISTB-2018-01)
 - Technical Bulletin ISTB-2018-04 City of Ottawa, March 2018. (ISTB-2018-04)
 - Technical Bulletin ISTB-2019-02 City of Ottawa, February 2019. (ISTB-2019-02)
- Ottawa Design Guidelines – Water Distribution, City of Ottawa, July 2010. (Ottawa Water Guidelines)
 - Technical Bulletin ISD-2010-2 City of Ottawa, December 15, 2010. (ISD-2010-2)
 - Technical Bulletin ISDTB-2014-02 City of Ottawa, May 2014. (ISDTB-2014-02)
 - Technical Bulletin ISTB-2018-02 City of Ottawa, March 2018. (ISTB-2018-02)
 - Technical Bulletin ISTB-2021-03 City of Ottawa, August 2021. (ISTB-2021-03)

2.2.2 Ministry of Environment, Conservation and Parks:

- Stormwater Planning and Design Manual, Ministry of the Environment, March 2003. (MECP Stormwater Design Manual)
- Design Guidelines for Sewage Works, Ministry of the Environment, 2008. (MECP Sewer Design Guidelines)

2.2.3 Other:

- Water Supply for Public Fire Protection, Fire Underwriters Survey, 2020. (FUS Guidelines)

3.0 PRE-CONSULTATION SUMMARY

A pre-consultation meeting was conducted on January 14, 2025, regarding the proposed site. Specific design parameters to be incorporated within this design include the following:

- Stormwater Management (SWM) quantity for separated area is to be less than pre-development conditions with a maximum 'C' of 0.5.
- On-site quality control at an enhanced level is required (80% TSS removal).
- Existing water and sanitary stubs are allowed to be used – connections to trunk sewer and easement sewer are typically not permitted.
- SWM design shall be completed as per the City guidelines.

The pre-consultation meeting feedback notes are included in Appendix B.

4.0 WATERMAIN

4.1 Existing Watermain

The site is located within the 2C pressure zone, as per the City of Ottawa Infrastructure Master Plan. A 305 mm watermain is located on St. Laurent Boulevard, a 305 mm watermain on Othello Avenue, and a 305 mm watermain on Pleasant Park Road are available to provide water service to the proposed development.

4.2 Proposed Watermain

New 200 mm diameter water services connected to the 305 mm diameter watermain within Othello Avenue are proposed to provide a redundant watermain loop to the development. The internal watermain contains water valves located at the property line and has been designed to have a minimum of 2.4 m cover. Each townhome unit will be equipped with a 19 mm service lateral. Two internal fire hydrants are proposed to protect the new townhome buildings. Refer to Site Servicing Plan for a detailed servicing layout.

The Fire Underwriters Survey 2020 (FUS) method was utilized to determine the required fire flow for the site. The 'C' factor (type of construction) for the FUS calculation was determined to be 1.5 (wood frame construction). The total floor area ('A' value) for the FUS calculation was determined to be 2,288 m² for each block. The results of the calculations yielded a required fire flow of 14,000 L/min for Blocks 1 and 3, and 15,000 L/min for Block 2. A maximum fire flow of 9,000 L/min was calculated for each block using the Ontario Building Code (OBC) criteria. The detailed calculations for the FUS and OBC can be found in Appendix C.

The water demands for the proposed building have been calculated to adhere to the Ottawa Water Guidelines and can be found in Appendix C. The results have been summarized in Table 1 below. These calculations account for the Blocks 1, 2 and 3.

Table 1: Water Demands

| Design Parameter | Value |
|--------------------------|-------------|
| Site Area | 2.42 ha |
| Residential | 350 L/c/day |
| Average Day Demand (L/s) | 0.71 |
| Maximum Day Demand (L/s) | 3.49 |
| Peak Hour Demand (L/s) | 5.28 |

Boundary conditions for the site were requested and received from the City on July 7, 2025. The model assumed demands for the property as - Average Day = 0.71 L/s, Maximum Day = 3.49 L/s and Maximum Hourly = 5.28 L/s, and the fire flow to be 233, 250 & 233 L/s, for Blocks 1, 2 and 3, respectively, results are summarized in Table 2 below.

Table 2: Boundary Conditions on Othello Avenue

| Scenario | Total HGL (m) | Head Pressure (m) | Head Pressure (psi) |
|---|---------------|-------------------|---------------------|
| Average Day (Maximum HGL) | 130.30 | 55.30 | 78.68 |
| Maximum Day + Fire Flow | 118.70 | 43.70 | 62.18 |
| Peak Hourly (Minimum HGL) | 124.70 | 49.70 | 70.71 |
| *Please note that the Maximum Day + Fire Flow is governed by Block 2 as the resultant fire flow was greatest for this building. | | | |

The boundary conditions were used to ensure the normal operating pressure range is not less than 275 kPa (40 psi) or more than 552 kPa (80 psi). The resultant hydraulic grade line (HGL) shows that the minimum pressure limit is satisfied during the average day and peak hour scenario. In addition to normal operations, the maximum day plus fire flow conditions were reviewed to ensure that there is sufficient fire flow available to meet the required flow rate, while maintaining a minimum of 20 psi (140 kPa) within the City's distribution system as per the Ottawa Water Guidelines, 2010. The resulting HGL shows that the minimum pressure is satisfied during a fire scenario.

In addition to the review of the boundary conditions, the available fire flow based on hydrant spacing was analysed as per the Ottawa Water Guidelines (ISTB 2018-02), Appendix I, Table 1. All existing and proposed municipal hydrants within 150 m clear distance to the nearest face of the building were used to find a combined available fire flow to support the site. Existing and proposed hydrants were assumed to be class AA (painted blue) by visual inspection through the latest imagery provided on Google Street View. A total contribution of 5,700 L/min and 3,800 L/min was used for each hydrant within 75 m, and between 75 m and 150 m of the building, respectively. The results are summarized below in Table 3.

Please refer to Appendix C for a hydrant location map and detailed calculations.

Table 3: Fire Hydrant Protection

| | Location | Assumed Class | Status | Distance (m) | Flow Contribution (L/min) |
|---------|------------------|---------------|----------|--------------|---------------------------|
| Block 2 | On-site | AA | Proposed | 14 | 5,700 |
| | Pleasant Park Rd | AA | Existing | 117 | 3,800 |
| | Othello Ave | AA | Existing | 14 | 5,700 |
| | Total | | | | 15,200 |
| Block 2 | Othello Ave | AA | Existing | 65 | 5,700 |
| | On-site | AA | Proposed | 13 | 5,700 |
| | Weston Dr | AA | Existing | 63 | 5,700 |
| | Total | | | | 17,100 |
| Block 2 | Weston Dr | AA | Existing | 61 | 5,700 |
| | St Laurent Blvd | AA | Existing | 104 | 3,800 |
| | On-site | AA | Proposed | 7 | 5,700 |
| | Total | | | | 15,200 |

Based on Ottawa Water Guidelines (ISTB-2018-02), the existing and proposed hydrants can provide adequate fire protection to the proposed development blocks per the required fire flows of 14,000, 15,000 and 14,000 L/min, for Blocks 1, 2 and 3, respectively.

4.3 Water Age Analysis

A water model was completed using EPANet modelling software to assess the water age within the proposed watermain network. A 5 day, 120 hour, analysis was carried out during an average day scenario to ensure the turnover rate was adequate. The results determined that the proposed 150-250 mm watermain network can adequately service the proposed development with a turnover rate of less than 7 hours. The results are summarized below and are included in Appendix C.

Table 4: Water Age Analysis

| Model Nodes | Water Quality (hours) |
|-------------|-----------------------|
| J1 | 2.44 |
| J2 | 3.97 |
| J3 | 5.31 |
| J4 | 6.75 |
| J5 | 0.23 |
| J6 | 1.71 |
| J7 | 0.41 |
| J8 | 1.08 |
| J9 | 3.87 |
| J10 | 2.62 |

5.0 SANITARY DESIGN

5.1 Existing Sanitary Sewer

There are existing 225 mm and 375 mm diameter sanitary sewers that run parallel to each other the entire length of the property along St. Laurent Blvd sloping south, ultimately tributary to the Green Creek Collector North.

There are existing 225 mm and 375 mm diameter sanitary sewers that run parallel to each other along St Pleasant Park Road sloping east. This main feeds into the main along St. Laurent, ultimately tributary to the Green Creek Collector.

There is an existing 225 mm diameter sanitary sewer that runs along Othello Ave sloping north. This sewer main increases to a 375 mm diameter pipe at Weston Dr which continues sloping west, ultimately tributary to the Green Creek Collector.

5.2 Proposed Sanitary Sewer

A new PVC gravity sanitary lateral is proposed to be connected to the existing sanitary sewer which outlets to the existing 375 mm diameter sanitary sewer in Othello Avenue to service the northern townhome block. A new 200 mm sanitary sewer connection to the Othello Avenue sanitary sewer is proposed to service the two remaining townhome blocks. Each townhome unit will be equipped with a 100 mm service lateral. Refer to civil drawing C102 for a detailed servicing layout.

The peak design flows for the proposed buildings were calculated using criteria from the Ottawa Sewer Guidelines and are summarized in Table 5. The proposed site development will generate a flow of 244 7 L/s under peak wet weather conditions. See Appendix D for more details.

Table 5: Sanitary Design Criteria

| Design Parameter | Value |
|-----------------------------|-------------|
| Site Area | 2.42 ha |
| Residential | 280 L/c/day |
| Extraneous Flow Allowance | 0.33 L/s/ha |
| Total Infiltration Flow | 0.37L/s |
| Average Dry Weather Flow | 0.63 L/s |
| Peak Sewage Flow | 2.07 L/s |
| Total Peak Wet Weather Flow | 2.44 L/s |

Due to the complexity of the downstream network, it is requested that the City advise of any additional downstream constraints not considered in this report that may be impacted by these flows. Please refer to Appendix D for detailed calculations.

6.0 STORM SEWER DESIGN

6.1 Existing Storm Sewers

There is an existing 375 mm diameter storm sewer that runs along St. Laurent Boulevard. The storm sewer slopes to the south and increases to a 450 mm diameter then a 525 mm diameter at each manhole adjacent to the property along St. Laurent Blvd. This sewer is tributary to the Ottawa River. The outlet to Ramsey Creek is approximately 1.9 km from the site.

There is an existing 300 mm diameter storm sewer that runs along Pleasant Park Avenue sloping west, ultimately tributary to the Ottawa River.

There is an existing 300 mm diameter storm sewer that runs along Othello Avenue sloping north. This run reaches a manhole at Weston Dr, increases to a 450 mm diameter pipe, and slopes west, ultimately tributary to the Ottawa River.

6.2 Proposed Storm Sewers

Storm sewers are proposed to convey storm flows from the parking area catch basins to the existing infrastructure on site, with no new connections to the municipal sewer system. Existing storm sewers and catch basins will be used for conveyance. Inlet Control Devices (ICDs) will be installed in existing and proposed maintenance holes as required to provide release rate control. An Oil Grit Separator (OGS) will be included for quality control. Overland flow routes and swales will also be utilized to manage surface-level conveyance.

7.0 PROPOSED STORMWATER MANAGEMENT

7.1 Design Criteria and Methodology

SWM for the proposed development will be maintained through positive drainage away from the proposed building and be conveyed toward municipal sewers. The overland flow route for the site will be directed back to the ROWs along Othello Avenue or Pleasant Park Road. The quantitative properties of the storm runoff for both the pre- and post-development flows are further detailed below.

In summary, the following design criteria have been employed in development of the SWM design for the site:

Quantity Control

- SWM quantity for separated area are to be less than pre-development 2-year conditions.

Quality Control

- Enhanced level is required (80% TSS removal).

7.2 Runoff Calculations

Runoff calculations presented in this report are derived using the Rational Method, given as:

$$Q = 2.78CIA \text{ (L/s)}$$

Where: C = Runoff coefficient

I = Rainfall intensity in mm/hr (City of Ottawa IDF curves)

A = Drainage area in ha

It is recognized that the Rational Method tends to overestimate runoff rates. As a result, the conservative calculation of runoff ensures that any SWM facility sized using this method is expected to function as intended.

The following coefficients were used to develop an average C for each area, summarized in Table 6.

Table 6: Runoff Coefficients

| Land Cover | C |
|--------------------------|------|
| Roofs/ Concrete/ Asphalt | 0.90 |
| Gravel | 0.60 |
| Undeveloped/ Grass | 0.20 |

As per the Ottawa Sewer Guidelines, the 5-Year balanced C-value must be increased by 25% for a 100-Year storm event to a maximum of 1.0.

7.3 Pre-Development Drainage

The existing site drainage limits are demonstrated on the Pre-Development Drainage Area Plan, included in Appendix F. A summary of the pre-development runoff calculations can be found in Table 7. Full SWM calculations are included in Appendix E.

Table 7: Pre-Development Runoff Summary

| Drainage Area | Area (ha) | Runoff Coefficient (2/5-Year) | Runoff Coefficient (100-Year) | 2-Year Peak Flow (L/s) | 5-Year Peak Flow (L/s) | 100-Year Peak Flow (L/s) |
|---------------|-----------|-------------------------------|-------------------------------|------------------------|------------------------|--------------------------|
| A1 | 1.27 | 0.74 | 0.83 | 200.36 | 272.84 | 523.40 |
| A2 | 0.62 | 0.80 | 0.89 | 105.62 | 143.83 | 275.09 |
| A3 | 0.31 | 0.90 | 1.00 | 59.25 | 80.68 | 153.63 |
| A4 | 0.23 | 0.46 | 0.53 | 22.31 | 30.38 | 59.79 |

The pre-development release rates that are to be met in the post-development conditions are summarized in Table 8.

Table 8: Required Restricted Flow

| Drainage Area | Area (ha) | Required Release Rate (L/s) (100-Year) |
|---------------|-----------|--|
| A1 | 1.27 | 200.36 |
| A2 | 0.62 | 275.09 |
| A3 | 0.31 | 153.63 |
| A4 | 0.23 | 59.79 |
| Total | | 688.88 |

The pre-development release rates that are to be met for Area A1 is the 2-year condition for the stormwater directed to Pleasant Park. For Area A2, the existing conditions are being improved by this development as there will be an increase in pervious area as a result of the development, however ICD's are still proposed to be installed to improve capacity of existing infrastructure. Area A3 encompass the existing apartment buildings on the property which remain unchanged. Lastly, Area A4 is the uncontrolled flow on the existing site. The overall site flows are to be less than the sum of the required release rates.

7.4 Post-Development Drainage Areas

The proposed site drainage limits are demonstrated on the Post-Development Drainage Area Plan found in Appendix G of this report. A summary of the post-development runoff calculations for the site are shown in Table 9. Full SWM calculations are included in Appendix E.

Table 9: Post-Development Runoff Summary

| Drainage Area | Unrestricted Flow (L/S) | | | Restricted Flow (L/S) | | | Storage Required (m ³) | | | Storage Provided (m ³) | | |
|-----------------------|-------------------------|--------|----------|-----------------------|--------|----------|------------------------------------|--------|----------|------------------------------------|--------|----------|
| | 2-Year | 5-Year | 100-Year | 2-Year | 5-Year | 100-Year | 2-Year | 5-Year | 100-Year | 2-Year | 5-Year | 100-Year |
| B1 | 70.20 | 95.60 | 183.88 | 10.00 | 10.10 | 33.40 | 23.21 | 40.9 | 111.3 | 24.8 | 42.8 | 111.7 |
| B2) | 110.59 | 150.59 | 288.76 | 21.81 | 24.81 | 35.57 | 75.03 | 115.5 | 269.4 | 77.3 | 118.9 | 269.1 |
| Total (Pleasant Park) | 180.79 | 246.18 | 472.64 | 31.81 | 34.91 | 68.97 | 98.24 | 156.39 | 380.73 | 102.16 | 161.76 | 380.80 |
| B3 | 96.71 | 131.70 | 252.45 | 70.30 | 83.03 | 127.16 | 21.58 | 35.0 | 92.8 | 22.69 | 35.8 | 99.9 |
| B4 | 59.25 | 80.68 | 153.63 | 59.25 | 80.68 | 153.63 | | | | | | |
| B5 | 37.21 | 50.67 | 99.23 | 37.21 | 50.67 | 99.23 | | | | | | |
| Total | 554.76 | 755.42 | 1450.60 | 230.37 | 284.21 | 448.99 | 218.06 | 347.81 | 854.27 | 227.01 | 359.29 | 861.52 |

7.5 Quantity Control

The total post-development runoff for this site has been restricted to match the required release rates outlined in Table 8. Reducing site flows will be achieved using flow restrictions and the existing onsite storage.

Area B1 conveys stormwater to the storm sewer in Pleasant Park Road. Flows are controlled to less than the pre-development 2-year condition through multiple ICDs to be installed in existing and proposed underground stormwater structures, yielding a restricted 100-year release rate of 33.40 L/s. Area B2 conveys stormwater to the sewer in Pleasant Park Road. Flows are also controlled to less than the pre-development 2-year condition through an ICD, yielding a restricted 100-year release rate of 35.57 L/s. Combined Areas B1 and B2 discharge at a total restricted 100-year rate of 68.97 L/s, which is less than the pre-development 2-year combined flow to Pleasant Park of 200.36 L/s.

Area B3 conveys water to the sewer in Othello. The proposed design improves stormwater quantity conditions by introducing additional landscaped area and opportunities for infiltration/seepage. The 100-year runoff rate is 127.16 L/s, we have multiple ICDs in underground infrastructure to improve flows and increase capacity of the existing infrastructure. Area B4 consists of the existing building, which remains unchanged, with a 100-year runoff rate of 153.63 L/s. Area B5 consists of uncontrolled runoff, with a 100-year rate of 99.23 L/s.

The proposed design controls Areas B1 and B2 to below the pre-development combined flow, improves stormwater conditions in Area B3, and maintains or manages Areas B4 and B5 as existing. Overall, the post-development runoff will be less than the pre-development condition.

See Appendix E for SWM calculations.

7.6 Quality Control

The development of this lot will employ Best Management Practices (BMP's) wherever possible. The intent of implementing stormwater BMP's is to ensure that stormwater quality and quantity concerns are addressed at all stages of development. Lot level BMP's typically include temporary retention of the lot runoff, minimizing ground slopes and maximizing landscaped areas. Some of these BMP's cannot be provided for this site due to site constraints and development requirements.

Three quality treatment unit has been proposed to provide a TSS removal rate of 80% as per the requirements. The OGS (Oil & Grit Separator) units will provide a stormwater quality of at least 80% TSS. The OGS units shall be placed downstream of the parking area's storm structures and sewers to provide the required water quality treatment for the site runoff before discharging to the municipal infrastructure. The units have been sized as a Stormceptor EFO4 which have been ETV verified. An approved equivalent will be acceptable for this site as well.

Three separate OGS units will be located per C102 to service Areas B1, B2 and B3. The OGS units will address this need by providing sediment and oil/grit removal before discharge to the sewer in Pleasant Park Road for Areas B1 and B2, and Othello Avenue for Area B3.

All relevant OGS details, authorizations, and sizing information have included in Appendix E.

8.0 EROSION AND SEDIMENT CONTROL

8.1 Temporary Measures

Before construction begins, temporary silt fence and straw bale/rock flow check dams will be installed at all natural runoff outlets from the property. It is crucial that these controls be maintained throughout construction and inspection of erosion and sediment control will be facilitated by the Contractor or Contract Administration staff throughout the construction period.

Silt fences will be installed where shown in the final engineering plans, specifically along the downstream property limits. The Contractor, at their discretion, or at the instruction of the Municipality, Conservation Authority, or Contract Administrator, shall increase the quantity of erosion and sediment controls on-site to ensure that the site is operating as intended and no additional sediment finds its way off site. The check dams and silt fences shall be inspected weekly and after rain events. Care shall be taken to properly remove sediment from the fences and check dams as required. Inlet sediment control devices (ISCD) are to be placed under the grates of all existing catch basins and manholes surrounding the site that will come in contact with flows during construction. Any new structures will have an ISCD installed immediately upon installation. The measures for the existing/proposed structures are to be removed only after all areas have been paved. Care shall be taken at the removal stage to ensure that any sediment that has accumulated is properly handled and disposed of. Removal of all silt fences and ISCDs prior to removal of the sediments shall not be permitted.

Although not anticipated, work through the winter months shall be closely monitored for erosion along sloped areas. Should erosion be noted, the Contractor shall be alerted and shall take all necessary steps to rectify the problematic area(s). Should the Contractor's efforts fail at remediating the eroded areas, the Contractor shall contact the Municipality and/or Conservation Authority to review the site conditions and determine the appropriate course of action. As the ground begins to thaw, the Contractor shall place silt fencing at all required locations as soon as the ground conditions warrant. Please see the Site Grading and Sediment & Erosion Control Plan for additional details regarding the temporary measures to be installed and their appropriate OPSD references.

8.2 Permanent Measures

Rip-rap will be placed at all locations that have the potential for concentrated flow. It is crucial that the Contractor ensure that the geotextile is keyed in properly to ensure runoff does not undermine the rip rapped area. Additional rip-rap is to be placed at erosion prone locations as identified by the Contractor / Contract Administrator / Municipality or Conservation Authority.

It is expected that the Contractor will promptly ensure that all disturbed areas receive topsoil and seed/sod and that grass be established as soon as possible. Any areas of excess fill shall be removed or levelled as soon as possible and must be located a sufficient distance from any watercourse to ensure that no sediment is washed out into the watercourse. As the vegetation growth within the site provides a key component to the control of sediment for the site, it must be properly maintained once established. Once the construction is complete, it will be up to the landowner to maintain the vegetation and ensure that the vegetation is not overgrown or impeded by foreign objects.

9.0 SUMMARY

- Three blocks of townhomes are to be developed along with associated additional parking spaces.
- 150mm and 200 mm service is proposed to service the site, connecting to the 300 mm watermain in Pleasant Park Road and Othello Avenue.
- 100mm sanitary service laterals and a new 200mm sewer runs within the property and will be connected to the existing infrastructure to outlet to the existing and proposed connections on Othello Avenue.
- New catchbasins and storm maintenance holes are being proposed to provide additional catchment areas. These structures will be connected to existing structures on site via 250mm and 375mm storm sewers.
- Storage for the 2-, 5- and 100-year storm events will be provided for affected areas via above-ground storage areas.
- Stormwater quality control will be provided on-site via three OGS units.

10.0 RECOMMENDATION

Based on the information presented in this report, we recommend that the Municipality approve this Servicing Report in support of the proposed development.

The report is respectfully being submitted for approval.

Regards,

Egis Canada Ltd.



Alison Gosling, P. Eng
Project Engineer, Land Development
+1 613-714-4629

Robbie Pickard, E.I.T.
Engineering Intern, Land Development
+1 613-808-3427

APPENDIX A
LOCATION PLAN



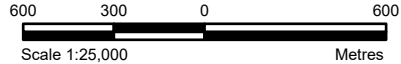
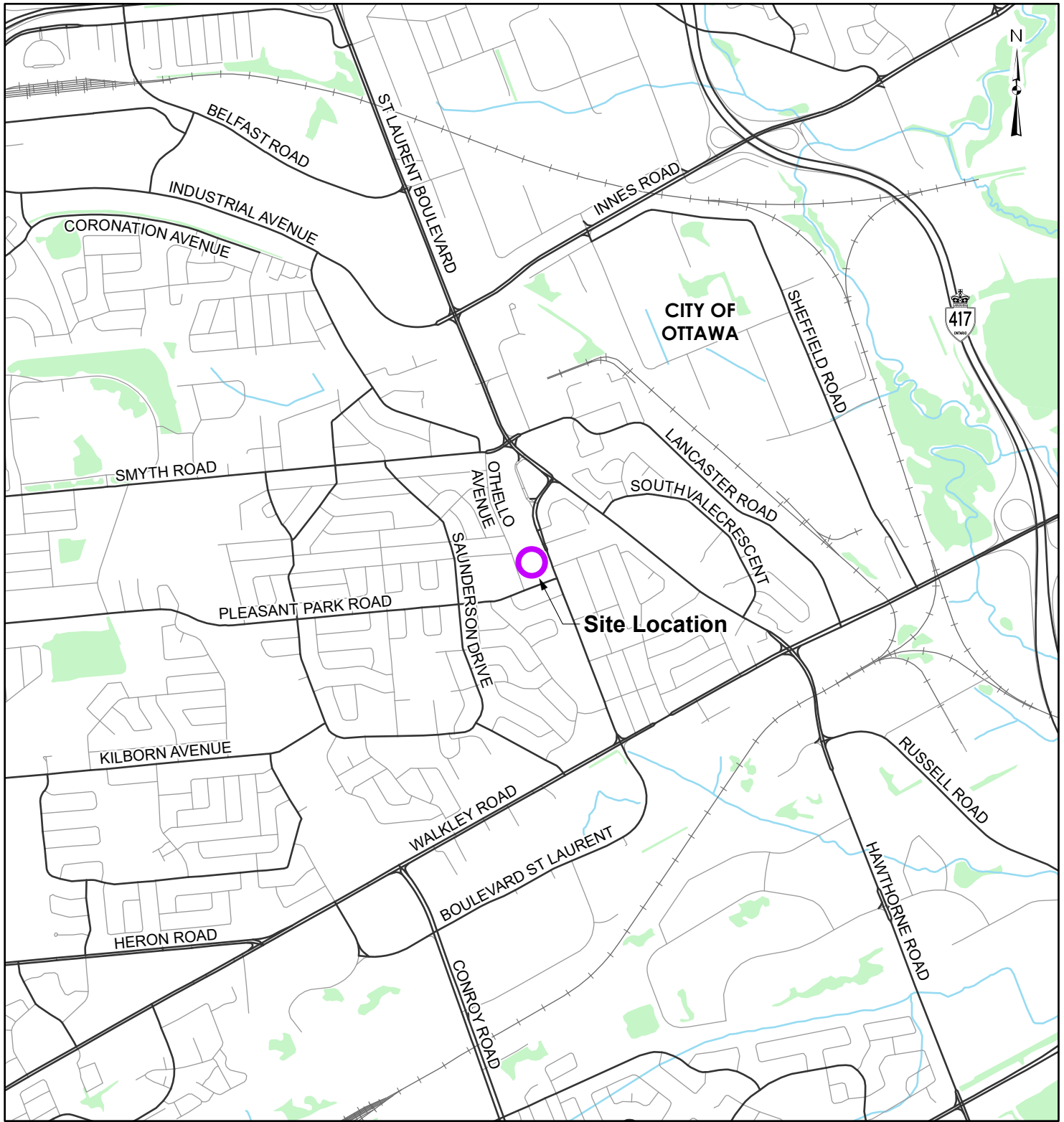

LEGEND

- Site Location
- Local Road
- Major Road
- Railroad
- Watercourse
- Waterbody
- Wooded Area

REFERENCE

GIS data provided by the Ontario Ministry of Natural Resources and Forestry, 2021.

| | | | |
|--|--|--|----------------|
| CLIENT: | | OSGOODE PROPERTIES | |
| PROJECT: | | 2025 OTHELLO AVENUE, OTTAWA, ON | |
| TITLE: | | SITE LOCATION PLAN | |
| McINTOSH PERRY 115 Walgreen Road, RR3, Carp, ON K0A1L0 Tel: 613-836-2184 Fax: 613-836-3742 www.mcintoshperry.com | | PROJECT NO: CCO-22-1241 | FIGURE: |
| | | Date | Aug., 13, 2021 |
| | | Checked By | BS |
| | | 1 | |

C:\Users\uncum\McIntosh Perry\GIS - Documents\Projects\2022\CCO\CCO-22-1241_Osgrade Properties - Pleasant Park - 2025 Othello Avenue\app\Key Map\LandDevelopment\CCO-22-1241_CommunityDev_Osgrade_SiteLocation.aprx

APPENDIX B
BACKGROUND DOCUMENTS





RE: 2025 Othello Avenue - Boundary condition Request

From Bramah, Bruce <bruce.bramah@ottawa.ca>

Date Wed 7/9/2025 8:53 AM

To RAPER Mitch <Mitch.RAPER@egis-group.com>

Cc PICKARD Robert <Robert.PICKARD@egis-group.com>; FREEL Robert <Robert.FREEL@egis-group.com>

1 attachment (316 KB)

2025 Othello Avenue June 2025.pdf;

/!\ Courriel externe - Merci d'être prudent avec les liens et les pièces jointes /!\ External email - Please be careful with links and attachments /!\

Good morning Mitch,

Please see boundary conditions below and attached:

The following are boundary conditions, HGL, for hydraulic analysis at 2025 Othello Avenue (zone 2W2C) assumed to be connected to the 305 mm watermain on Othello Avenue [**Option 1**] **OR** the 305 mm watermain on Pleasant Park Rd [**Option 2**] (see attached PDF for location).

- Option 1 (Othello Avenue):

Minimum HGL: 124.7 m

Maximum HGL: 130.3 m

Maximum Day + Fire Flow (250 L/s): 118.7 m

Option 2 (Pleasant Park Rd):

Minimum HGL: 124.7 m

Maximum HGL: 130.2 m

Maximum Day + Fire Flow (250 L/s): 120.1 m

These are for current conditions and are based on computer model simulation.

Disclaimer:

The boundary condition information is based on current operation of the city water distribution system. The computer model simulation is based on the best information available at the time. The operation of the water distribution system can change on a regular basis, resulting in a variation in boundary conditions. The physical properties of watermains deteriorate over time, as such must be assumed in the absence of actual field test data. The variation in physical watermain properties can therefore alter the results of the computer model simulation.

Fire Flow analysis is a reflection of available flow in the watermain; there may be additional restrictions that occur between the watermain and the hydrant that the model cannot take into account.

"The IWSD has recently updated their water modelling software. Any significant difference between previously received BC results and newly received BC results could be attributed to this update."

Thanks,

--

Bruce Bramah, P.Eng

Project Manager

Planning, Development and Building Services department (PDBS)/ Direction générale des services de la planification, de l'aménagement et du bâtiment (DGSPAB) - South Branch

City of Ottawa | Ville d'Ottawa

110 Laurier Avenue West Ottawa, ON | 110, avenue. Laurier Ouest. Ottawa (Ontario) K1P 1J1

613.580.2424 ext. 29686, Bruce.Bramah@ottawa.ca

Classified as City of Ottawa - Internal / Ville d'Ottawa - classé interne

From: RAPER Mitch <Mitch.RAPER@egis-group.com>
Sent: June 19, 2025 8:34 AM
To: Bramah, Bruce <bruce.bramah@ottawa.ca>
Cc: PICKARD Robert <Robert.PICKARD@egis-group.com>; FREEL Robert <Robert.FREEL@egis-group.com>
Subject: RE: 2025 Othello Avenue - Boundary condition Request

CAUTION: This email originated from an External Sender. Please do not click links or open attachments unless you recognize the source.

ATTENTION : Ce courriel provient d'un expéditeur externe. Ne cliquez sur aucun lien et n'ouvrez pas de pièce jointe, excepté si vous connaissez l'expéditeur.

Hi Bruce,

The intent would be to make one connection to a public main and extend a private watermain within the site which will service each proposed block of towns. The connection figure was to illustrate that this proposed connection is to be made either on Pleasant Park Road or Othello Avenue so we will require boundary conditions for both depending on the proposed servicing layout in the design phase.

Please let me know if additional details are required.

Kind regards,

From: Bramah, Bruce <bruce.bramah@ottawa.ca>
Sent: June 18, 2025 9:58 AM
To: RAPER Mitch <Mitch.RAPER@egis-group.com>
Cc: PICKARD Robert <robert.pickard@egis-group.com>; FREEL Robert <robert.freel@egis-group.com>
Subject: RE: 2025 Othello Avenue - Boundary condition Request

/!\ Courriel externe - Merci d'être prudent avec les liens et les pièces jointes /!\ External email - Please be careful with links and attachments /!\

Good morning Mitch,

Can you please clarify how you plan to service these blocks of back to back towns? Are you proposing a separate connection to the public main for each block with a private watermain loop around the towns to provide individual service connections to each stacked unit? The connection figure does not note the connection for Block 3.

Please clarify and provide a revised connection figure.

Thanks,

--

Bruce Bramah, P.Eng

Project Manager

Planning, Development and Building Services department (PDBS)/ Direction générale des services de la planification, de l'aménagement et du bâtiment (DGSPAB) - South Branch

City of Ottawa | Ville d'Ottawa

110 Laurier Avenue West Ottawa, ON | 110, avenue. Laurier Ouest. Ottawa (Ontario) K1P 1J1

613.580.2424 ext. 29686, Bruce.Bramah@ottawa.ca

Classified as City of Ottawa - Internal / Ville d'Ottawa - classé interne

From: Sharif, Golam <sharif.sharif@ottawa.ca>
Sent: June 17, 2025 4:02 PM
To: Bramah, Bruce <bruce.bramah@ottawa.ca>
Subject: FW: 2025 Othello Avenue - Boundary condition Request

FYI

Classified as City of Ottawa - Internal / Ville d'Ottawa - classé interne

From: RAPER Mitch <Mitch.RAPER@egis-group.com>
Sent: Tuesday, June 17, 2025 3:34 PM
To: Sharif, Golam <sharif.sharif@ottawa.ca>
Cc: PICKARD Robert <Robert.PICKARD@egis-group.com>; FREEL Robert <Robert.FREEL@egis-group.com>
Subject: 2025 Othello Avenue - Boundary condition Request

CAUTION: This email originated from an External Sender. Please do not click links or open attachments unless you recognize the source.

ATTENTION : Ce courriel provient d'un expéditeur externe. Ne cliquez sur aucun lien et n'ouvrez pas de pièce jointe, excepté si vous connaissez l'expéditeur.

Hi Sharif,

We would like to request updated boundary conditions for the proposed development at 2025 Othello Avenue. The proposed development proposes 3 residential back-to-back townhouses.

For the purpose of boundary conditions, we would like to request watermain pressures from both potential connection points (Connection #1 and Connection #2) on both Othello Avenue and Pleasant Park Road.

- The estimated fire flow is 15,000 L/min based on the 2020 FUS
- Average daily demand: 0.71 L/s
- Maximum daily demand 3.49 L/s
- Maximum hourly daily 5.28 L/s

Attached is a map showing the proposed connection location(s) along with the calculations prepared for the demands listed above.

Please let me know if you have any questions..

Thank you,

Ce message et ses pièces jointes peuvent contenir des informations confidentielles ou privilégiées et ne doivent donc pas être diffusés, exploités ou copiés sans autorisation. Si vous avez reçu ce message par erreur, merci de le signaler à l'expéditeur et le détruire ainsi que les pièces jointes. Les messages électroniques étant susceptibles d'altération, Egis décline toute responsabilité si ce message a été altéré, déformé ou falsifié. Merci.

This message and its attachments may contain confidential or privileged information that may be protected by law; they should not be distributed, used or copied without authorisation. If you have received this email in error, please notify the sender and delete this message and its attachments. As emails may be altered, Egis is not liable for messages that have been modified, changed or falsified. Thank you.

This e-mail originates from the City of Ottawa e-mail system. Any distribution, use or copying of this e-mail or the information it contains by other than the intended recipient(s) is unauthorized. Thank you.

Le présent courriel a été expédié par le système de courriels de la Ville d'Ottawa. Toute distribution, utilisation ou reproduction du courriel ou des renseignements qui s'y trouvent par une personne autre que son destinataire prévu est interdite. Je vous remercie de votre collaboration.

Ce message et ses pièces jointes peuvent contenir des informations confidentielles ou privilégiées et ne doivent donc pas être diffusés, exploités ou copiés sans autorisation. Si vous avez reçu ce message par erreur, merci de le signaler à l'expéditeur et le détruire ainsi que les pièces jointes. Les messages électroniques étant susceptibles d'altération, Egis décline toute responsabilité si ce message a été altéré, déformé ou falsifié. Merci.

This message and its attachments may contain confidential or privileged information that may be protected by law; they should not be distributed, used or copied without authorisation. If you have received this email in error, please notify the sender and delete this message and its attachments. As emails may be altered, Egis is not liable for messages that have been modified, changed or falsified. Thank you.

This e-mail originates from the City of Ottawa e-mail system. Any distribution, use or copying of this e-mail or the information it contains by other than the intended recipient(s) is unauthorized. Thank you.

Le présent courriel a été expédié par le système de courriels de la Ville d'Ottawa. Toute distribution, utilisation ou reproduction du courriel ou des renseignements qui s'y trouvent par une personne autre que son destinataire prévu est interdite. Je vous remercie de votre collaboration.

~~December 18, 2024~~

Jan 14, 2025 – Updated with Urban Design Comments

Tyler Yakichuk
Fotenn Planning and Design
Via email: yakichuk@fotenn.com

**Subject: Pre-Consultation: Meeting Feedback
Proposed Site Plan Control Application – 2025 Othello Avenue**

Please find below updated comments from the Urban Design-focused meeting on Jan 14, 2025.

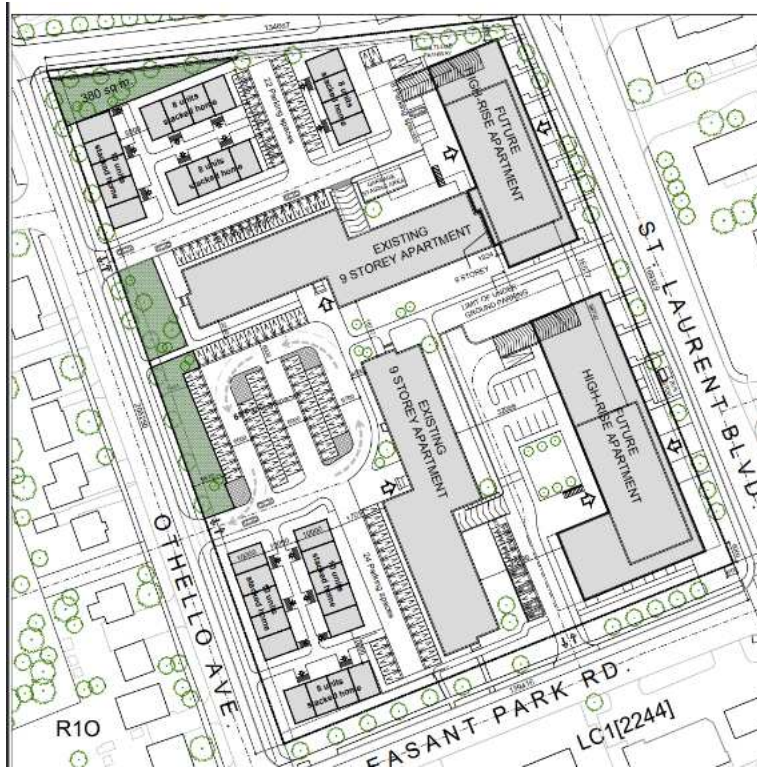

March 2024 Submission, above, showing the previous proposal, along with the 2 proposed high-rise towers that were the subject of a ZBLA, which has since been revoked.



Nov 2024 submission above.

Pre-Consultation Preliminary Assessment

| | | | | |
|----------------------------|----------------------------|---------------------------------------|----------------------------|----------------------------|
| 1 <input type="checkbox"/> | 2 <input type="checkbox"/> | 3 <input checked="" type="checkbox"/> | 4 <input type="checkbox"/> | 5 <input type="checkbox"/> |
|----------------------------|----------------------------|---------------------------------------|----------------------------|----------------------------|

One (1) indicates that considerable major revisions are required while five (5) suggests that the proposal appears to meet the City's key land use policies and guidelines. This assessment is purely advisory and does not consider technical aspects of the proposal or in any way guarantee application approval.

Next Steps

1. A review of the proposal and materials submitted for the above-noted pre-consultation has been undertaken. Please proceed to complete a Phase 2 Pre-consultation Application Form and submit it together with the necessary studies and/or plans to planningcirculations@ottawa.ca.
2. In your subsequent pre-consultation submission, please ensure that all comments or issues detailed herein are addressed. A detailed cover letter stating how each issue has been addressed must be included with the submission materials. Please coordinate the numbering of your responses within the cover letter with the comment number(s) herein.
3. Please note, if your development proposal changes significantly in scope, design, or density before the Phase 3 pre-consultation, you may be required to complete or repeat the Phase 2 pre-consultation process.

Supporting Information and Material Requirements

1. The attached **Study and Plan Identification List** outlines the information and material that has been identified, during this phase of pre-consultation, as either required (R) or advised (A) as part of a future complete application submission.
 - a. The required plans and studies must meet the City's Terms of Reference (ToR) and/or Guidelines, as available on Ottawa.ca. These ToR and Guidelines outline the specific requirements that must be met for each plan or study to be deemed adequate.

Consultation with Technical Agencies

1. You are encouraged to consult with technical agencies early in the development process and throughout the development of your project concept. A list of technical agencies and their contact information is enclosed.

File History

2021 Proposal:

- OPA/ZBLA File Number D01-01-21-0023/D02-02-21-0132
- The Applicant previously proposed one 27-storey residential building, one 18-storey residential building, 255 bicycle parking spaces, 786 vehicular parking spaces, 2,605m² of communal amenity space and 253m² of parkland in the northwest corner of the site. Of the 766 vehicular parking spaces proposed, 180 were planned at grade and 606 underground.
- OPA to permit the height increase from 9-storeys to 27-storeys. This file is no longer required due to the new policies in the current Official Plan.
- ZBLA to permit a max height increase of up to 83.1 metres. This application is currently still active (comments were sent from the City on Nov 23, 2022, but there has not been any further activity on this file).

April 2024 Proposal:

- The current proposal is to build 7 stacked townhouses, 62 dwelling units, and 413 associated parking spots at the north-west and south-west corners of the site, on the existing surface parking lots of the larger apartment building complex site.
- The Applicant indicated that the current proposal is for stacked towns, but that ultimately, they would like to rezone and construct the high rises from the 2021 proposal.

November 2024 Proposal:

- Applicant has stated that the development is fully compliant.
- 3 "Metro town" blocks, 76 units, 76 residential parking spaces for the new towns, 16 visitor parking spaces for the new towns, including barrier free
- 370 residential/visitor parking spaces for the 2 existing apartment buildings
- Soft Landscaping Area: 6,017.06 square metres. This is the combined area of many small pieces of land that also function as setbacks and are not useable for any type of amenity space.

Planning – Tracey Scaramozzino

Deficiencies:

1. To be deemed complete, the submission must meet all of the requirements identified in the ToR for Site Plan:
https://documents.ottawa.ca/sites/documents/files/site_plan_tor_en.pdf
 - a. Many items from the TOR for Site Plan are missing, such as: Reference to survey plan, legend, length of property lines, hts (in storeys and metres) of existing and proposed buildings, highlighting of the pedestrian connections to and through the site, legal property description, with PIN, legend showing materiality (asphalt, concrete, sod etc), fencing, snow storage or a note to say it will be removed from site, bike parking details etc.)
2. Ensure zoning table (on the site plan) and zoning compliance report is accurate and shows all zoning provisions applicable to the development, including standard and AODA parking specifications, amenity space etc.

Comments:

1. City staff will review this property as one site with one site plan control application, since they function as 1 site.
2. It is recommended that a courtesy heads-up be provided to the local ward Councillor Marty Carr – Ward 18.
3. Is adequate amenity space being provided for the existing towers (6m²/du with min 50% communal – S 137).
4. Is adequate amenity space being provided for the proposed stacked dwellings that contain 9+ dwelling units? (S 137)
5. Consider the following: Increase tree plantings – especially along St. Laurent, which has a very poor score for pedestrian safety and enjoyability; reduce hard scape or mitigate other areas to reduce the heat island impact.
6. Consider the merits of improving pedestrian connections as per the additional orange lines and removal of some of the pink in the rough sketches below:

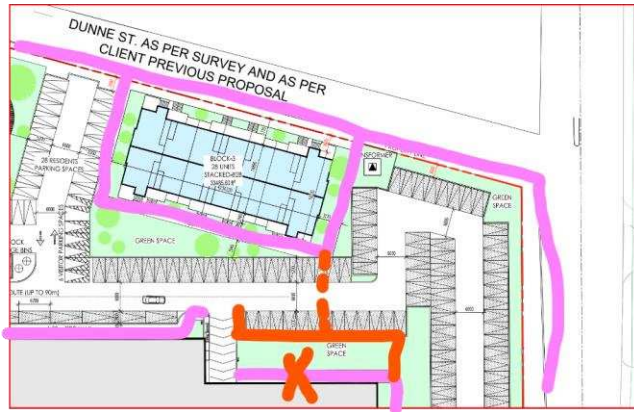

7. If, in the future, the Owners wish to further re-develop the site, the proposal will be assessed at that time, based on current policy, zoning and the developed context of the site and area.

Urban Design – Lisa Stern – updated Jan 14, 2025

Submission Requirements:

1. Urban Design Brief is required. Please see attached customized Terms of Reference to guide the preparation.
 - a. The Urban Design Brief should be structured by generally following the headings highlighted under Section 3 – Contents of these Terms of Reference.
 - b. The proposal is within a design priority area however not subject to the Urban Design Review Panel as the proposed stacked dwellings do not meet the height threshold.

2. Additional drawings and studies are required as shown on the ASPIL. Please follow the terms of references ([Planning application submission information and materials | City of Ottawa](#)) the prepare these drawings and studies.
 - a. Design Brief
 - b. Site Plan
 - c. Landscape Plan
 - d. Elevations
 - e. Floor plans (conceptual)

Comments on Preliminary Design Applicants are to provide a response to these comments in the Design Brief.

1. A Design Brief is required as part of the submission. The Terms of Reference of the Design Brief is attached for convenience. As indicated in the Terms of Reference:
 - a. It is important to discuss and explore the overall development opportunities on site through a master site plan, examine the overall site organization, including building placement and massing, vehicular and pedestrian circulation, servicing, delineation and/or integration of public spaces and private realm, before finalizing the design of the proposed development. Please consider the function of the existing buildings – separation of back of house (garbage, loading, parking ramps) vs. front of house (front doors, gateways) should be considered
 - b. The master plan should address the two tower proposal submitted with zoning amendment application D02-02-21-0131.
 - c. With respect to the proposed development itself, it is important to explore building placement options, examine these options against both the existing and planned contexts, and demonstrate how the proposed development will relate to the rest of the site (existing and future), the public realm, as well as the abutting properties.
 - d. Please ensure that the shadow analysis addresses the cumulative shadow of the ultimate build out of the site to ensure that there are no negative impacts to the proposed park.
2. Preliminary Design Comments:
 - a. Please ensure that building placement ensures a pleasant and logical development of the site in the ultimate condition.
 - b. A direct E-W pedestrian connection through the site should be provided from Othello to St. Laurent.
 - c. Opportunities for on-site tree planting should be examined. Look for opportunities to increase the ‘front’ and ‘corner side’ yards of internal stacked dwellings to provide tree planting on internal roadways and create a more pleasant residential feel.
 - d. Please ensure that existing street trees along Othello can be retained – placement of front doors and walkways should take existing trees into account.

- e. Please ensure that parking is screened from the public roadways.
- f. In consideration of the ultimate build out of the site, it may be beneficial to provide some underground parking for the proposed stacked dwellings to create a more logical order to the site and provide additional opportunities for landscaping.
- g. The existing forecourt between the two existing towers is a functional and gracious entrance to the site. Please enhance its role as a gateway into the site and a functional pick up/drop off area for the apartments.
- h. Please remove parking adjacent to the proposed park. You may rotate block 3 90 degrees to provide park frontage and provide a shoulder to shoulder condition to the apartment.
- i. Look for opportunities to create a network of amenity areas and maximize areas for tree plantings.

Engineering – Bruce Bramah – Dec 18, 2024: these have not been updated.

*Deficiencies aren't noted, as no plans and studies for engineering review were submitted.

Comments:

Existing Public Infrastructure



- St-Laurent Blvd.
 - 450mm storm sewer
 - 250mm sanitary sewer
- Othello Avenue
 - 375mm sanitary sewer, flow towards St-Laurent
 - 375mm sanitary sewer, flow towards Weston Drive
 - 300mm storm sewer
- Pleasant Park
 - 375mm sanitary sewer, flow towards St-Laurent
 - 225mm sanitary sewer, flow towards Valley Drive
 - 300mm storm sewer

The Stormwater Management Criteria, for the subject site, is to be based on the following:

- a. Application of the IDF information derived from the Meteorological Services of Canada rainfall data, taken from the MacDonald Cartier Airport, collected 1966 to 1997.

- b. For separated sewer systems built up until 2016, the design of the storm sewers were based on a 5-year storm; storm systems after such time are, generally, based on a 2-year level-of-service.
- c. In separated areas, the pre-development runoff shall be the lower of the existing coefficient or a maximum equivalent 'C' of 0.5, whichever is less (§ 8.3.7.3).
- d. A calculated time of concentration (cannot be less than 10 minutes).
- e. Flows to the storm sewer in excess of the 2-year storm release rate, up to and including the 100-year storm event, must be detained on site. No ponding during the 2-year event shall occur.
- f. Storm sewer outlets should not be submerged.
- g. Quality control will be required to provide 80% TSS removal.
- h. It would be preferred to have one service connection to public infrastructure for the proposed development. If multiple connections are required due to site layout, discussions with the IPM should occur prior to submission.

Deep Services (Storm, Sanitary and/or Water Supply)

- a. Provide existing servicing information and the recommended location for the proposed connections. Services should ideally be grouped in a common trench to minimize the number of road cuts.
- b. Connections to trunk sewers and easement sewers are typically not permitted.
- c. Provide information on the monitoring manhole requirements – should be located in an accessible location on private property near the property line (ie. Not in a parking area).
- d. Review provision of a high-level sewer.
- e. Sewer connections to be made above the springline of the sewermain as per:
 - i. Std Dwg S11.1 for flexible main sewers – connections made using approved tee or wye fittings.
 - ii. Std Dwg S11 (For rigid main sewers) – lateral must be less than 50% the diameter of the sewermain,
 - iii. Std Dwg S11.2 (for rigid main sewers using bell end insert method) – for larger diameter laterals where manufactured inserts are not

available; lateral must be less than 50% the diameter of the sewermain,

- iv. Connections to manholes permitted when the connection is to rigid main sewers where the lateral exceeds 50% the diameter of the sewermain. – Connect obvert to obvert with the outlet pipe unless pipes are a similar size.

An MECP Environmental Compliance Approval **[Municipal/Private Sewage Works]** may be required for the proposed development. A Ministry contact has been provided below but please work with City staff on the need (or not) of an application.

Patrick Lalonde at (613) 521-3450 or Patrick.Lalonde@ontario.ca

Shannon Hamilton-Browne at (613) 521-3450 or Shannon.Hamilton-Browne@ontario.ca

Water

- a. Water Boundary condition requests must include the location of the service (map or plan with connection location(s) indicated) and the expected loads required by the existing, proposed and future development (separate demands), including calculations. Please provide the following information:

Location of service

Type of development

The amount of fire flow required (per OBC or FUS).

Average daily demand: ___ l/s.

Maximum daily demand: ___ l/s.

Maximum hourly daily demand: ___ l/s.

Please provide the peak sanitary demands for the existing, proposed, and future development when boundary conditions are requested.

Feel free to contact Bruce Bramah, Project Manager, for follow-up questions.

Noise – Mike Giampa Dec 18, 2024: these have not been updated.

Comments:

- 1. A detailed road noise study is required.

Feel free to contact Mike Giampa, TPM, for follow-up questions.

Transportation – Mike Giampa Dec 18, 2024: these have not been updated.

Comments:

2. Concrete sidewalks are required fronting the new site. Sidewalks should be continuous and depressed through all private approaches (new and existing).

Differentiate between existing and proposed private approaches on site plan.

Right-of-way protection.

- a. See Schedule C16 of the Official Plan.
- b. Any requests for exceptions to ROW protection requirements must be discussed with Transportation Planning and concurrence provided by Transportation Planning management.

Corner Sight Triangle required at intersections as per the new policy:

- a. Arterial/Arterial: overlapping 5m x 15m triangles
- b. Arterial/Collector: overlapping 5m x 15m triangles
- c. Collector/Collector: overlapping 5m x 15m triangles
- d. Arterial/Local: 3m x 9m with the longer dimension along the arterial road
- e. Collector/Local: 3m x 9m with the longer dimension along the collector road
- f. Local/Local: 3m x 3m
- g. Any exceptions to the above must be approved by Transportation Planning – specifically Max Walker from Transportation Policy & Networks.

A TIA submission is not required for 62 units. Previous 2021 Zoning/OPA TIA feedback may still be applicable.

Feel free to contact Mike Giampa, Transportation Project Manager, for follow-up questions.

Environment – Mark Elliott – no new comments for the Dec 2024 submission

Comments:

1. An Environmental Impact Statement is not required for this application. There are no natural heritage features, surface water features, or endangered species habitat present on site that would trigger the need for an EIS.
2. The Bird Safe Design Guidelines apply to any residential building above four storeys in height. Please note that Guideline 2 of the BSDG's require that 90% of all glazing 16m and below in height must incorporate some form of mitigation for bird mortality. The Bird Safe Design Guidelines can be found at this link.

3. Additional tree plantings to help meet the City's forest canopy goals as well as reduce the impacts of climate change and urban heat island are encouraged. The City prefers that plantings be of native and non-invasive species. Other interventions that help combat extreme heat such as green roofs and water features should also be considered.

Feel free to contact Mark Elliott, Environmental Planner, for follow-up questions.

Forestry – Hayley Murray Dec 18, 2024: these have not been updated.

TCR Comments

1. This looks to be a positive concept plan, with the majority of the proposed buildings within existing parking/cleared areas.

Building and underground parking must be set back sufficiently from the existing trees in all ROWs to allow for their retention and future growth. Walkways must be located outside of the Critical Root Zones of any existing trees, maximizing the space available for future growth.

It is a strong priority to retain as many of the existing trees and space as possible in the entry feature on Othello.

A Tree Conservation Report is required, in accordance with Schedule E of the Tree Protection By-law. Ownership of all trees on the subject site and with Critical Root Zones extending onto the subject site must be determined, and plans must show how they will be protected from proposed works.

Section 4.8.2 of the New Official Plan provides strong direction to maintain the urban forest canopy and its ecosystem services during intensification noting when considering the impacts on individual trees, planning and development decisions, including Committee of Adjustment decisions, shall give priority to the retention and protection of large, healthy trees over replacement plantings and compensation. Applications must address the cumulative impacts on the urban forest, over time and space, with the goal of 40% urban forest canopy cover in mind. Further, that the City and the Committee of Adjustment may refuse a development application where it deems the loss of a tree(s) avoidable.

If any shared or adjacent trees are impacted by the proposal, the applicant is responsible for consulting with the owners of the trees and for obtaining signed permission if any trees must be removed. If no permission is granted, plans must be designed to allow for the full protection of these trees.

A permit is required prior to removal of any protected trees on site. The tree permit will be released upon site plan approval. Please contact the planner associated with the file or the Planning Forester, Hayley Murray (Hayley.murray@ottawa.ca) for information on obtaining the tree permit.

To ensure that no harm is caused to breeding birds, tree removal and vegetation clearing should be avoided during the migratory bird season (April 15 – August 15) as specified by The City of Ottawa's Environmental Impact Study Guidelines.

Landscape Plan Comments

1. A Landscape Plan is required with this application and must address all requirements within the Landscape Plan Terms of Reference https://documents.ottawa.ca/sites/documents/files/landscape_tor_en.pdf , including the projection of canopy cover toward the target of 40%, and confirmation of adequate soil volumes to support any proposed trees.

The Landscape Plan must show the setback distances between proposed and existing trees to buildings and underground structures to ensure that both the above and below-ground space proposed is sufficient for tree planting in the Right of Way and other landscaped areas.

The Official Plan section 4.8.2, sub 3 provides the following direction related to tree planting related to site plans:

- a) Preserve and provide space for mature, healthy trees on private and public property, including the provision of adequate volumes of high-quality soil as recommended by a Landscape Architect;
- b) On urban properties subject to site plan control or community planning permits, development shall create tree planting areas within the site and in the adjacent boulevard, as applicable, that meet the soil volume requirements in any applicable City standards or best management practices or in accordance with the recommendation of a Landscape Architect;

Insufficient greenspace is proposed through this development. Opportunities must be found to provide consolidated soft landscaped area for tree planting, shade, and outdoor amenity space for residents, including around the stacked townhouse units.

The Landscape Plan must provide details of adequate soil depth for any trees proposed on top of underground parking.

TCR requirements:

1. a Tree Conservation Report (TCR) must be supplied for review along with the suite of other plans/reports required by the City
2. an approved TCR is a requirement of Site Plan approval.
3. The TCR may be combined with the LP provided all information is supplied
4. Any removal of privately-owned trees 10cm or larger in diameter, or city-owned trees of any diameter requires a tree permit issued under the Tree

- Protection Bylaw (Bylaw 2020 – 340); the permit will be based on an approved TCR and made available at or near plan approval.
5. Compensation may be required for the removal of city owned trees.
 6. The TCR must contain 2 separate plans:
 7. Plan/Map 1 - show existing conditions with tree cover information
 8. Plan/Map 2 - show proposed development with tree cover information
 9. Please ensure retained trees are shown on the landscape plan
 10. the TCR must list all trees on site, as well as off-site trees if the CRZ extends into the developed area, by species, diameter and health condition
 11. please identify trees by ownership – private onsite, private on adjoining site, city owned, co-owned (trees on a property line)
 12. If trees are to be removed, the TCR must clearly show where they are, and document the reason they cannot be retained
 13. All retained trees must be shown, and all retained trees within the area impacted by the development process must be protected as per City guidelines available at [Tree Protection Specification](#) or by searching [Ottawa.ca](#)
 14. the location of tree protection fencing must be shown on the plan
 15. show the critical root zone of the retained trees
 16. the City encourages the retention of healthy trees; if possible, please seek opportunities for retention of trees that will contribute to the design/function of the site.
 17. For more information on the process or help with tree retention options, contact Nancy Young (Nancy.young@ottawa.ca) or on [City of Ottawa](#)

Landscape Plan tree planting requirements:

The City recommends the following Best Management Practices to improve the climate change resiliency of new developments:

- For parking lots, provide 1 new tree for every 5 parking spaces to help cool the landscape of the site.
- Confirm sufficient Soil volumes to support canopy cover on site (30m³ for street trees)
- Proposed species must not include invasive species and target a minimum of 50% native species

Minimum Setbacks

- Maintain 1.5m from sidewalk or MUP/cycle track or water service laterals.
- Maintain 2.5m from curb
- Coniferous species require a minimum 4.5m setback from curb, sidewalk or MUP/cycle track/pathway.
- Maintain 7.5m between large growing trees, and 4m between small growing trees. Park or open space planting should consider 10m spacing, except where otherwise approved in naturalization / afforestation areas. Adhere to

Ottawa Hydro’s planting guidelines (species and setbacks) when planting around overhead primary conductors.

Tree specifications

- Minimum stock size: 50mm tree caliper for deciduous, 200cm height for coniferous.
- Maximize the use of large deciduous species wherever possible to maximize future canopy coverage
- Tree planting on city property shall be in accordance with the City of Ottawa’s Tree Planting Specification; and include watering and warranty as described in the specification (can be provided by Forestry Services).
- Plant native trees whenever possible
- No root barriers, dead-man anchor systems, or planters are permitted.
- No tree stakes unless necessary (and only 1 on the prevailing winds side of the tree)
- Hard surface planting
- Curb style planter is highly recommended
- No grates are to be used and if guards are required, City of Ottawa standard (which can be provided) shall be used.
- Trees are to be planted at grade

Soil Volume

- Please document on the LP that adequate soil volumes can be met:

| Tree Type/Size | Single Tree Soil Volume (m3) | Multiple Tree Soil Volume (m3/tree) |
|----------------|------------------------------|-------------------------------------|
| Ornamental | 15 | 9 |
| Columnar | 15 | 9 |
| Small | 20 | 12 |
| Medium | 25 | 15 |
| Large | 30 | 18 |
| Conifer | 25 | 15 |

Please note that these soil volum Clay.

Sensitive Marine Clay

- Please follow the City’s 2017 Tree Planting in Sensitive Marine Clay guidelines

Tree Canopy



- The landscape plan shall show how the proposed tree planting will replace and increase canopy cover on the site over time, to support the City's 40% urban forest canopy cover target.

At a site level, efforts shall be made to provide as much canopy cover as possible, through tree planting and tree retention, with an aim of 40% canopy cover at 40 years, as appropriate. Indicate on the plan the projected future canopy cover at 40 years for the site.

For additional information on the following please contact Nancy Young (Nancy.young@ottawa.ca).

Parks Planning – Steve Gauthier – December 2024

The proposed narrow park portion (see below) is not acceptable/non-programmable and needs to be redistributed/consolidated with the rest of the parkland dedication to achieve more depth from Othello Avenue.



Other, Dec 18, 2024: these have not been updated.

The High Performance Development Standard (HPDS) is a collection of voluntary and required standards that raise the performance of new building projects to achieve sustainable and resilient design. The HPDS was passed by Council on April 13, 2022.

- a. At this time, the HPDS is not in effect and Council has referred the 2023 HPDS Update Report back to staff with direction to bring forward an updated report to Committee with recommendations for revised phasing timelines, resource requirements and associated amendments to the Site Plan Control By-law by no later than Q1 2024.



- b. Please refer to the HPDS information attached and ottawa.ca/HPDS for more information.

Submission Requirements and Fees

1. The attached **Study and Plan Identification List** outlines the information and material that has been identified as either required (R) or advised (A) as part of a future complete application submission.
 - a. The required plans and studies must meet the City's Terms of Reference (ToR) and/or Guidelines, as available on Ottawa.ca. These ToR and Guidelines outline the specific requirements that must be met for each plan or study to be deemed adequate.
2. All of the above comments or issues should be addressed to ensure the effectiveness of the application submission review.

Should there be any questions, please do not hesitate to contact myself or the contact identified for the above areas / disciplines.

Yours Truly,
Tracey Scaramozzino

- c.c. Bruce Bramah, Infrastructure Approvals PM
Mike Giampa, Transportation PM
Mark Elliott, Environmental Planner
Hayley Murray, City Forester
Lisa Stern, Urban Designer
Steve Gauthier, Park Planner

APPENDIX A

List of Technical Agencies to Consult

Proposed Site Plan Control Application – 2025 Othello Avenue – PC2024-0123

| | | |
|-------------------------------------|---|---|
| <input checked="" type="checkbox"/> | Zayo | Utility.Circulations@Zayo.com |
| <input checked="" type="checkbox"/> | Bell Canada | circulations@wsp.com |
| <input checked="" type="checkbox"/> | Telus Communications | Engineering.Requests@telus.com / jovica.stojanovski@telus.com |
| <input checked="" type="checkbox"/> | Rogers Communications | OPE.Ottawa@rci.rogers.com |
| <input checked="" type="checkbox"/> | Enbridge Gas Distribution | municipalplanning@enbridge.com |
| <input checked="" type="checkbox"/> | O.C. District School Board | planningcirculations@ocdsb.ca |
| <input checked="" type="checkbox"/> | O.C. Catholic School Board | planningcirculations@ocsb.ca |
| <input checked="" type="checkbox"/> | Conseil des écoles publiques | planification@cepeo.on.ca |
| <input checked="" type="checkbox"/> | Conseil des écoles catholiques du Centre-Est | planification@ecolecatholique.ca |
| <input checked="" type="checkbox"/> | Hydro Ottawa (Local Distribution) | ExternalCirculations@HydroOttawa.com |
| <input type="checkbox"/> | Hydro One Networks (Transmission) | landuseplanning@hydroone.com |
| <input type="checkbox"/> | Ontario Power Generation | Executivevp.lawanddevelopment@opg.com |
| <input type="checkbox"/> | Trans Canada Pipeline c/o Lehman & Associates | dpresley@mhbcplan.com |
| <input type="checkbox"/> | Trans Northern Pipeline Inc. | wwatt@tnpi.com |
| <input type="checkbox"/> | Railways | Choose an item |
| <input type="checkbox"/> | National Capital Commission | Ted.Horton@ncc-ccn.ca |
| <input type="checkbox"/> | Parks Canada | Tom.Green@pc.gc.ca |
| <input type="checkbox"/> | Airport Authority | Choose an item |
| <input type="checkbox"/> | Transport Canada | aviation.ont@tc.gc.ca |
| <input type="checkbox"/> | Ministry of Transportation | Via MTO's online portal . Note that MTO approval will be required ahead of applying for a building permit. |
| <input type="checkbox"/> | Infrastructure Ontario | NoticeReview@infrastructureontario.ca |
| <input type="checkbox"/> | Propane Operator | Mailing Addresses Only |
| <input type="checkbox"/> | NAV Canada | landuse@navcanada.ca |
| <input checked="" type="checkbox"/> | Conservation Authority | RVCA – planning@rvca.ca |

APPENDIX C WATERMAIN CALCULATIONS

COO-22-1241 - 2025 Othello Avenue

| | |
|--------------|---------------------|
| Project: | 2025 Othello Avenue |
| Project No.: | COO-22-1241 |
| Designed By: | MR |
| Checked By: | RF |
| Date: | December 12, 2025 |
| Site Area: | 2.42 gross ha |

| Residential | NUMBER OF UNITS | UNIT RATE | |
|---------------------|-----------------|-------------|---------------|
| 2 Bedroom Apartment | 48 units | 2.1 | persons/ unit |
| 3 Bedroom Apartment | 24 units | 3.1 | persons/ unit |
| Total Population | | 176 persons | |

AVERAGE DAILY DEMAND

| DEMAND TYPE | AMOUNT | UNITS | |
|-------------------------------|---------------------------------------|-----------------------------|------|
| Residential | 350 | L/ c/ d | |
| Industrial - Light | 35,000 | L/ gross ha/ d | |
| Industrial - Heavy | 55,000 | L/ gross ha/ d | |
| Shopping Centres | 2,500 | L/ (1000m ² / d) | |
| Hospital | 900 | L/ (bed/ day) | |
| Schools | 70 | L/ (Student/ d) | |
| Trailer Park with no Hook-Ups | 340 | L/ (space/ d) | |
| Trailer Park with Hook-Ups | 800 | L/ (space/ d) | |
| Campgrounds | 225 | L/ (campsite/ d) | |
| Mobile Home Parks | 1,000 | L/ (Space/ d) | |
| Motels | 150 | L/ (bed-space/ d) | |
| Hotels | 225 | L/ (bed-space/ d) | |
| Tourist Commercial | 28,000 | L/ gross ha/ d | |
| Other Commercial | 28,000 | L/ gross ha/ d | |
| AVERAGE DAILY DEMAND | Residential | 0.71 | L/ s |
| | Commercial/ Industrial/ Institutional | 0.00 | L/ s |

MAXIMUM DAILY DEMAND

| DEMAND TYPE | AMOUNT | UNITS | |
|----------------------|---------------------------------------|------------|------|
| Residential | 4.9 | x avg. day | |
| Industrial | 1.5 | x avg. day | |
| Commercial | 1.5 | x avg. day | |
| Institutional | 1.5 | x avg. day | |
| MAXIMUM DAILY DEMAND | Residential | 3.49 | L/ s |
| | Commercial/ Industrial/ Institutional | 0.00 | L/ s |

MAXIMUM HOUR DEMAND

| DEMAND TYPE | AMOUNT | UNITS | |
|---------------------|---------------------------------------|------------|------|
| Residential | 7.4 | x avg. day | |
| Industrial | 1.8 | x max. day | |
| Commercial | 1.8 | x max. day | |
| Institutional | 1.8 | x max. day | |
| MAXIMUM HOUR DEMAND | Residential | 5.28 | L/ s |
| | Commercial/ Industrial/ Institutional | 0.00 | L/ s |

WATER DEMAND DESIGN FLOWS PER UNIT COUNT
CITY OF OTTAWA - WATER DISTRIBUTION GUIDELINES, JULY 2010

| | | |
|----------------------|------|------|
| AVERAGE DAILY DEMAND | 0.71 | L/ s |
| MAXIMUM DAILY DEMAND | 3.49 | L/ s |
| MAXIMUM HOUR DEMAND | 5.28 | L/ s |

2025 Othello Avenue Block 1

| | |
|--------------|-----------------------------|
| Project: | 2025 Othello Avenue Block 1 |
| Project No.: | CCO-22-1241 |
| Designed By: | MR |
| Checked By: | RF |
| Date: | December 12, 2025 |

Ontario 2006 Building Code Compendium (Div. B - Part 3)

Water Supply for Fire-Fighting - Block 1

Building is classified as Group : C- Residential (from table 3.2.2.55)

Building is of combustible construction. Floor assemblies are fire separations, but with no fire-resistance rating. Roof assemblies, mezzanines, loadbearing walls, columns and arches do not have a fire-resistance rating.

From Div. B A-3.2.5.7. of the Ontario Building Code - 3. Building On-Ste Water Supply:

$$(a) Q = K \times V \times S_{tot}$$

where:

Q = minimum supply of water in litres

K = water supply coefficient from Table 1

V = total building volume in cubic metres

S_{tot} = total of spatial coefficient values from the property line exposures on all sides as obtained from the formula:

$$S_{tot} = 1.0 + [S_{side1} + S_{side2} + S_{side3} + \dots \text{etc.}]$$

| | | |
|------------------|----------------|--|
| K | 23 | (from Table 1 pg A-31) |
| V | 43,770 | (Total building volume in m ³ , provided by Architect.) |
| S _{tot} | 1.0 | (From figure 1 pg A-32) |
| Q = | 1,006,710.00 L | |



| | | | From Figure 1 (A-32) |
|--------|------|-----|----------------------|
| Shorth | 25 m | 0.0 | |
| Seast | 25 m | 0.0 | |
| Ssouth | 25 m | 0.0 | |
| Swest | 25 m | 0.0 | |

* approximate distances

From Table 2: Required Minimum Water Supply Flow Rate (L/s)

| | |
|-------------|------------------|
| 9,000 L/min | if Q > 270,000 L |
| 2378 gpm | |
| 150 L/s | |

2025 Othello Avenue Block 2

| | |
|--------------|-----------------------------|
| Project: | 2025 Othello Avenue Block 2 |
| Project No.: | CCO-22-1241 |
| Designed By: | MR |
| Checked By: | RF |
| Date: | December 12, 2025 |

Ontario 2006 Building Code Compendium (Div. B - Part 3)

Water Supply for Fire-Fighting - Building B

Building is classified as Group : C- Residential (from table 3.2.2.55)

Building is of combustible construction. Floor assemblies are fire separations, but with no fire-resistance rating. Roof assemblies, mezzanines, loadbearing walls, columns and arches do not have a fire-resistance rating.

From Div. B A-3.2.5.7. of the Ontario Building Code - 3. Building On-Site Water Supply:

$$(a) Q = K \times V \times S_{tot}$$

where:

Q = minimum supply of water in litres

K = water supply coefficient from Table 1

V = total building volume in cubic metres

S_{tot} = total of spatial coefficient values from the property line exposures on all sides as obtained from the formula:

$$S_{tot} = 1.0 + [S_{side1} + S_{side2} + S_{side3} + \dots \text{etc.}]$$

| | | |
|------------------|----------------|--|
| K | 23 | (from Table 1 pg A-31) |
| V | 43,770 | (Total building volume in m ³ , provided by Architect.) |
| S _{tot} | 1.0 | (From figure 1 pg A-32) |
| Q = | 1,006,710.00 L | |



| | | | From Figure 1 (A-32) |
|--------|------|-----|----------------------|
| Snorth | 17 m | 0.0 | |
| Seast | 33 m | 0.0 | |
| Ssouth | 25 m | 0.0 | |
| Swest | 25 m | 0.0 | |

* approximate distances

From Table 2: Required Minimum Water Supply Flow Rate (L/s)

| | |
|-------------|------------------|
| 9,000 L/min | if Q > 270,000 L |
| 2378 gpm | |
| 150 L/s | |

2025 Othello Avenue Block 3

| | |
|--------------|-----------------------------|
| Project: | 2025 Othello Avenue Block 3 |
| Project No.: | CCO-22-1241 |
| Designed By: | MR |
| Checked By: | RF |
| Date: | December 12, 2025 |

Ontario 2006 Building Code Compendium (Div. B - Part 3)

Water Supply for Fire-Fighting - Building C

Building is classified as Group : C- Residential (from table 3.2.2.55)

Building is of combustible construction. Floor assemblies are fire separations, but with no fire-resistance rating. Roof assemblies, mezzanines, loadbearing walls, columns and arches do not have a fire-resistance rating.

From Div. B A-3.2.5.7. of the Ontario Building Code - 3. Building On-Site Water Supply:

$$(a) Q = K \times V \times S_{tot}$$

where:

Q = minimum supply of water in litres

K = water supply coefficient from Table 1

V = total building volume in cubic metres

S_{tot} = total of spatial coefficient values from the property line exposures on all sides as obtained from the formula:

$$S_{tot} = 1.0 + [S_{side1} + S_{side2} + S_{side3} + \dots \text{etc.}]$$

| | | |
|------------------|----------------|---|
| K | 23 | (from Table 1 pg A-31) |
| V | 43,770 | (Total building volume in m ³ .) |
| S _{tot} | 1.0 | (From figure 1 pg A-32) |
| Q = | 1,006,710.00 L | |

| | | | From Figure 1 (A-32) |
|-------|------|-----|----------------------|
| North | 20 m | 0.0 | |
| East | 50 m | 0.0 | |
| South | 26 m | 0.0 | |
| West | 19 m | 0.0 | |

* approximate distances

From Table 2: Required Minimum Water Supply Flow Rate (L/s)

9,000 L/min if Q > 270,000 L
2378 gpm

000-22-1241 - 2025 Othello Avenue Block 1 - Fire Underwriters Survey - Townhouse

Project: 2025 Othello Avenue Block 1
 Project No.: 000-22-1241
 Designed By: MR
 Checked By: PF
 Date: December 12, 2025

From the Fire Underwriters Survey (2020)

From Part II – Guide for Determination of Required Fire Flow Copyright I.S.O.:
 City of Ottawa Technical Bulletin ISTB-2018-02 Applied Where Applicable

A. BASE REQUIREMENT (Rounded to the nearest 1000 L/min)

F = 220 x C x vA Where: F = Required fire flow in liters per minute
 C = Coefficient related to the type of construction.
 A = The total floor area in square meters (including all storey's, but excluding basements at least 50 percent below grade) in the building being considered.

Construction Type **Wood Frame**

C 1.5

Total Floor Area (per the 2020 FUS Page 20 - Total Effective Area) 2,288.0 m² * Unprotected Vertical Openings

Calculated Fire Flow 15,784.9 L/min
 16,000.0 L/min

B. REDUCTION FOR OCCUPANCY TYPE (No Rounding)

From Page 24 of the Fire Underwriters Survey:
 Limited Combustible -15%

Fire Flow 13,600.0 L/min

C. REDUCTION FOR SPRINKLER TYPE (No Rounding)

Non-Sprinklered 0%

Reduction 0.0 L/min

D. INCREASE FOR EXPOSURE (No Rounding)

| | Separation Distance (m) | Cons. of Exposed Wall | Length Exposed Adjacent Wall (m) | Height (Stories) | Length-Height Factor | % Increase* | |
|------------|-------------------------|---|----------------------------------|------------------|----------------------|-------------|-------|
| Exposure 1 | 20.1 to 30 | Ordinary - Mass Timber (Protected) | 39 | 9 | 351.0 | 1% | East |
| Exposure 2 | Over 30 m | Fire Resistive - Non Combustible (Unprotected Openings) | NA | NA | NA | 0% | South |
| Exposure 3 | Over 30 m | Wood frame | NA | 2 | NA | 0% | West |
| Exposure 4 | 20.1 to 30 | Wood frame | 18.0 | 3 | 54.0 | 4% | North |
| | | | | | | % Increase* | 5% |

Increase* 680.0 L/min

E. Total Fire Flow (Rounded to the Nearest 1000 L/min)

Fire Flow 14,280.0 L/min
 Fire Flow Required* 14,000.0 L/min

* In accordance with Part II, Section 4, the Increase for separation distance is not to exceed 75%

** In accordance with Section 4 the Fire flow is not to exceed 45,000 L/min or be less than 2,000 L/min

000-22-1241 - 2025 Othello Avenue Block 2 - Fire Underwriters Survey - Townhouse

Project: 2025 Othello Avenue Block 2
 Project No.: 000-22-1241
 Designed By: MR
 Checked By: PF
 Date: December 12, 2025

From the Fire Underwriters Survey (2020)

From Part II – Guide for Determination of Required Fire Flow Copyright I.S.O.:
 City of Ottawa Technical Bulletin ISTB-2018-02 Applied Where Applicable

A. BASE REQUIREMENT (Rounded to the nearest 1000 L/min)

F = 220 x C x vA Where: F = Required fire flow in liters per minute
 C = Coefficient related to the type of construction.
 A = The total floor area in square meters (including all storey's, but excluding basements at least 50 percent below grade) in the building being considered.

Construction Type Wood Frame

C 1.5

Total Floor Area (per the 2020 FUS Page 20 - Total Effective Area) 2,288.0 m² * Unprotected Vertical Openings

Calculated Fire Flow 15,784.9 L/min
 16,000.0 L/min

B. REDUCTION FOR OCCUPANCY TYPE (No Rounding)

From Page 24 of the Fire Underwriters Survey:
 Limited Combustible -15%

Fire Flow 13,600.0 L/min

C. REDUCTION FOR SPRINKLER TYPE (No Rounding)

Non-Sprinklered 0%

Reduction 0.0 L/min

D. INCREASE FOR EXPOSURE (No Rounding)

| | Separation Distance (m) | Cons. of Exposed Wall | Length Exposed Adjacent Wall (m) | Height (Stories) | Length-Height Factor | % Increase* | |
|------------|-------------------------|---|----------------------------------|------------------|----------------------|-------------|-------|
| Exposure 1 | 10.1 to 20 | Fire Resistive - Non Combustible (Unprotected Openings) | 37 | 9 | 333.0 | 6% | North |
| Exposure 2 | Over 30 m | Wood frame | NA | NA | NA | 0% | East |
| Exposure 3 | 20.1 to 30 | Wood frame | 18 | 3 | 54.0 | 4% | South |
| Exposure 4 | Over 30 m | Fire Resistive - Non Combustible (Unprotected Openings) | NA | NA | NA | 0% | West |
| | | | | | | % Increase* | 10% |

Increase* 1,360.0 L/min

E. Total Fire Flow (Rounded to the Nearest 1000 L/min)

Fire Flow 14,960.0 L/min
 Fire Flow Required* 15,000.0 L/min

* In accordance with Part II, Section 4, the Increase for separation distance is not to exceed 75%

** In accordance with Section 4 the Fire flow is not to exceed 45,000 L/min or be less than 2,000 L/min

000-22-1241 - 2025 Othello Avenue Block 3 - Fire Underwriters Survey - Townhouse

Project: 2025 Othello Avenue Block 3
 Project No.: 000-22-1241
 Designed By: MR
 Checked By: PF
 Date: December 12, 2025

From the Fire Underwriters Survey (2020)

From Part II – Guide for Determination of Required Fire Flow Copyright I.S.O.:
 City of Ottawa Technical Bulletin ISTB-2018-02 Applied Where Applicable

A. BASE REQUIREMENT (Rounded to the nearest 1000 L/min)

F = 220 x C x vA Where: F = Required fire flow in liters per minute
 C = Coefficient related to the type of construction.
 A = The total floor area in square meters (including all storey's, but excluding basements at least 50 percent below grade) in the building being considered.

Construction Type Wood Frame

C 1.5

Total Floor Area (per the 2020 FUS Page 20 - Total Effective Area) 2,288.0 m² * Unprotected Vertical Openings

Calculated Fire Flow 15,784.9 L/min
 16,000.0 L/min

B. REDUCTION FOR OCCUPANCY TYPE (No Rounding)

From Page 24 of the Fire Underwriters Survey:
 Limited Combustible -15%

Fire Flow 13,600.0 L/min

C. REDUCTION FOR SPRINKLER TYPE (No Rounding)

Non-Sprinklered 0%

Reduction 0.0 L/min

D. INCREASE FOR EXPOSURE (No Rounding)

| | Separation Distance (m) | Cons. of Exposed Wall | Length Exposed Adjacent Wall (m) | Height (Stories) | Length-Height Factor | % Increase* | |
|------------|-------------------------|---|----------------------------------|------------------|----------------------|-------------|-------|
| Exposure 1 | Over 30 m | Fire Resistive - Non Combustible (Unprotected Openings) | NA | NA | N/A | 0% | North |
| Exposure 2 | Over 30 m | Ordinary - Mass Timber (Unprotected) | N/A | NA | N/A | 0% | East |
| Exposure 3 | 20.1 to 30 | Fire Resistive - Non Combustible (Unprotected Openings) | 42 | 9 | 378.0 | 2% | South |
| Exposure 4 | Over 30 m | Fire Resistive - Non Combustible (Unprotected Openings) | NA | NA | NA | 0% | West |
| | | | | | | % Increase* | 2% |

Increase* 272.0 L/min

E. Total Fire Flow (Rounded to the Nearest 1000 L/min)

Fire Flow 13,872.0 L/min
 Fire Flow Required* 14,000.0 L/min

* In accordance with Part II, Section 4, the Increase for separation distance is not to exceed 75%

** In accordance with Section 4 the Fire flow is not to exceed 45,000 L/min or be less than 2,000 L/min

000-22-1241 - 2025 Othello Ave - Boundary Condition Unit Conversion

Project: 2025 Othello Ave
 Project No.: 000-22-1241
 Designed By: RP
 Checked By: CM
 Date: December 12, 2025

Boundary Conditions Unit Conversion

Othello

| Scenario | Height (m) | Elevation (m) | m H ₂ O | PSI | kPa |
|--|------------|---------------|--------------------|------|-------|
| Avg. DD | 130.30 | 75.00 | 55.30 | 0.00 | 78.68 |
| Fire Flow (250 L/s or 15,000 L/min) | 118.70 | 75.00 | 43.70 | 5.28 | 62.18 |
| Peak Hour | 124.70 | 75.00 | 49.70 | 0.00 | 70.71 |

CO-22-1241 - 2025 Othello Ave - Hydrant Availability

| | |
|--------------|-------------------|
| Project: | 2025 Othello Ave |
| Project No.: | CO-22-1241 |
| Designed By: | FP |
| Checked By: | JB |
| Date: | December 12, 2025 |

AVAILABLE FIRE FLOWS BASED ON HYDRANT SPACING

BASED ON CITY OF OTTAWA TECHNICAL BULLITEN ISTB-2018-02

| Location | Municipal or Private | Colour or Class (If Known) | 2025 Othello Ave | |
|---|----------------------|-------------------------------|---------------------------|---|
| | | | ¹ Distance (m) | ² Fire Flow Contribution (L/min) |
| On-site | Private | Blue (Class AA) | 14 | 5,700 |
| Pleasant Park Rd | Municipal | Blue (assume class AA) | 117 | 3,800 |
| Othello Ave | Municipal | Blue (assume class AA) | 14 | 5,700 |
| Total (L/min) | | | | 15,200 |
| FUS PFF in L/min or (L/sec) | | | | 14,000 (233) |
| Notes: | | | | |
| ¹ Distance is measured along a road or fire route to nearest face of building. | | | | |
| ² Fire Flow Contribution based on Table 1 of Appendix I, ISTB-2018-02 | | | | |

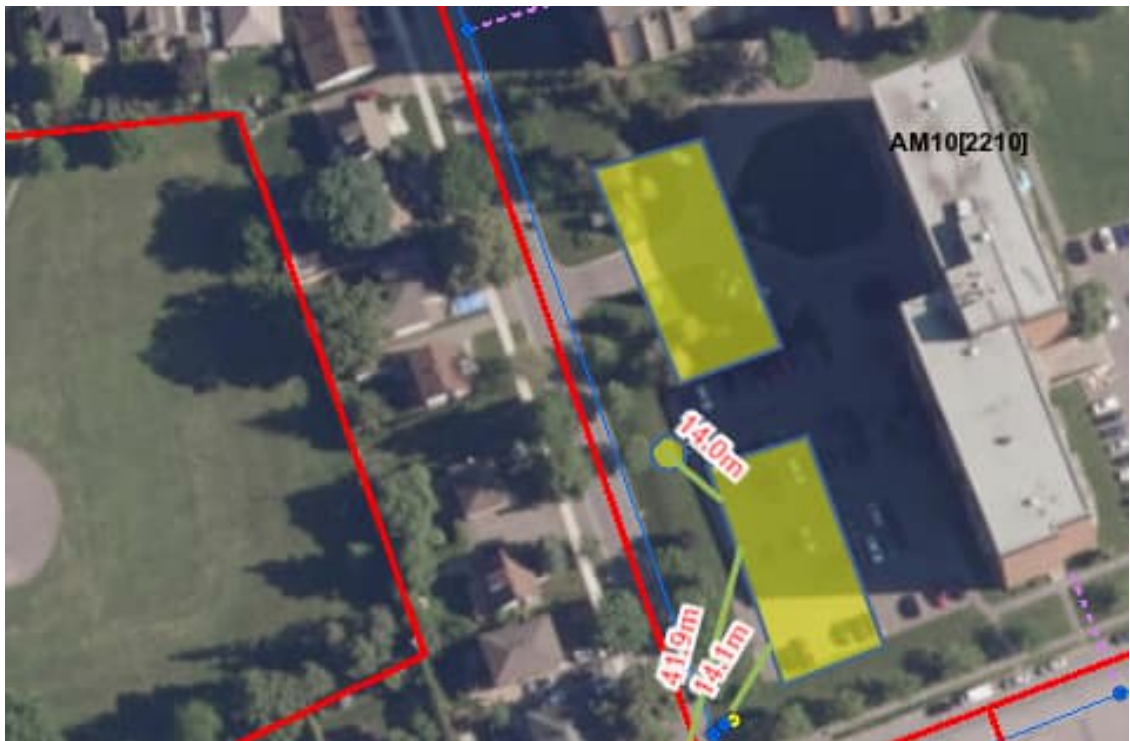

CO-22-1241 - 2025 Othello Ave - Hydrant Availability

| | |
|--------------|-------------------|
| Project: | 2025 Othello Ave |
| Project No.: | CO-22-1241 |
| Designed By: | FP |
| Checked By: | JB |
| Date: | December 12, 2025 |

AVAILABLE FIRE FLOWS BASED ON HYDRANT SPACING

BASED ON CITY OF OTTAWA TECHNICAL BULLITEN ISTB-2018-02

| Location | Municipal or Private | Colour or Class (If Known) | 2025 Othello Ave | |
|--|----------------------|-------------------------------|---------------------------|---|
| | | | ¹ Distance (m) | ² Fire Flow Contribution (L/min) |
| Othello Ave | Municipal | Blue (assume class AA) | 65 | 5,700 |
| On-site | Private | Blue (Class AA) | 13 | 5,700 |
| Weston Dr | Municipal | Blue (assume class AA) | 63 | 5,700 |
| Total (L/min) | | | | 17,100 |
| FUS PFF in L/min or (L/sec) | | | | 14,000 (233) |
| Notes: ¹ Distance is measured along a road or fire route to nearest face of building. ² Fire Flow Contribution based on Table 1 of Appendix I, ISTB-2018-02 | | | | |



OO-22-1241 - 2025 Othello Ave - Hydrant Availability

Project: 2025 Othello Ave
 Project No.: OO-22-1241
 Designed By: RP
 Checked By: JB
 Date: December 12, 2025

AVAILABLE FIRE FLOWS BASED ON HYDRANT SPACING

BASED ON CITY OF OTTAWA TECHNICAL BULLETIN ISTB-2018-02

| Location | Municipal or Private | Colour or Class (If Known) | 2025 Othello Ave | |
|---|----------------------|-------------------------------|---------------------------|---|
| | | | ¹ Distance (m) | ² Fire Flow Contribution (L/min) |
| Weston Dr | Municipal | Blue (assume class AA) | 61 | 5,700 |
| St Laurent Blvd | Municipal | Blue (assume class AA) | 104 | 3,800 |
| On-site | Private | Blue (Class AA) | 7 | 5,700 |
| Total (L/min) | | | | 15,200 |
| FUSRFF in L/min or (L/sec) | | | | 15,000 (250) |
| Notes: | | | | |
| ¹ Distance is measured along a road or fire route to nearest face of building. | | | | |
| ² Fire Flow Contribution based on Table 1 of Appendix I, ISTB-2018-02 | | | | |



2025 Othello Avenue EPANet Water Age Model - Average Day Scenario

Minimum HGL=124.7m, Maximum HGL=130.3m, Maximum Day + Fire Flow (250L/s)=118.7m

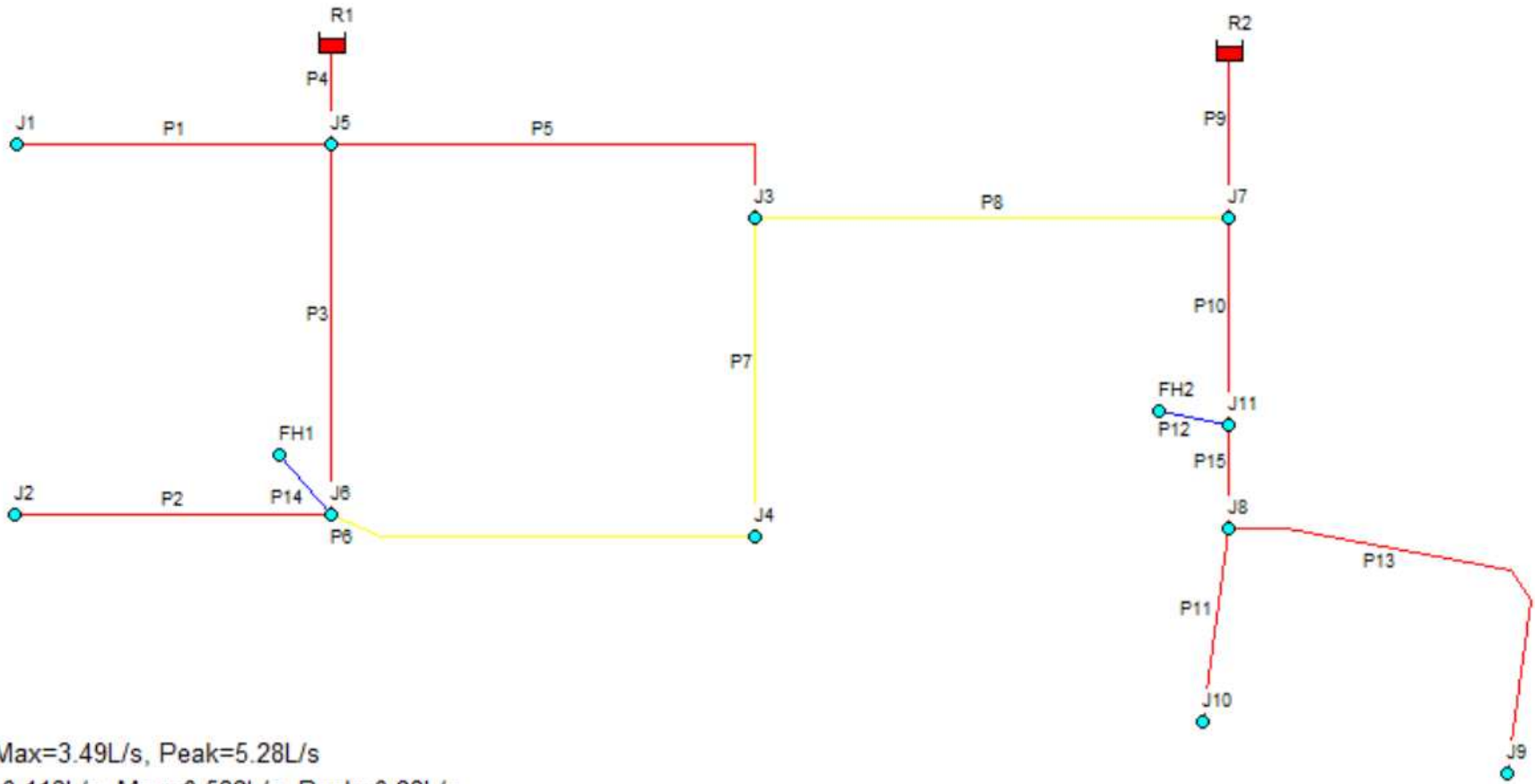
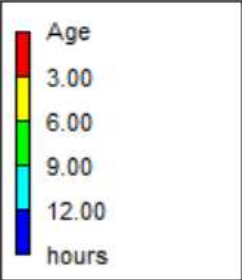
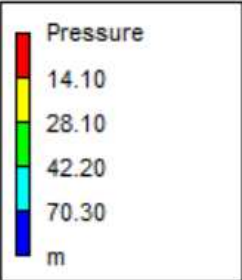

Total Demands: Avg=0.71L/s, Max=3.49L/s, Peak=5.28L/s
 Demands Per Node (1/6): Avg=0.118L/s, Max=0.582L/s, Peak=0.88L/s

```

*****
*                               E P A N E T                               *
*                               Hydraulic and Water Quality              *
*                               Analysis for Pipe Networks                *
*                               Version 2.2                              *
*****
    
```

Input File: 2025-11-21 - base model - AVG.net

Link - Node Table:

| Link ID | Start Node | End Node | Length m | Diameter mm |
|---------|------------|----------|----------|-------------|
| P1 | J1 | J5 | 53.2 | 150 |
| P4 | J5 | R1 | 9.9 | 200 |
| P3 | J5 | J6 | 27.5 | 200 |
| P2 | J2 | J6 | 54.4 | 150 |
| P6 | J6 | J4 | 45.5 | 150 |
| P7 | J4 | J3 | 21.6 | 150 |
| P5 | J5 | J3 | 52.2 | 200 |
| P8 | J3 | J7 | 57.5 | 200 |
| P9 | R2 | J7 | 15.5 | 200 |
| P12 | FH2 | J11 | 10.1 | 200 |
| P10 | J7 | J11 | 15.9 | 200 |
| P11 | J8 | J10 | 36.8 | 150 |
| P13 | J8 | J9 | 67.2 | 150 |
| P14 | FH1 | J6 | 5.8 | 200 |
| P15 | J11 | J8 | 3.8 | 150 |

Node Results at 0:00 Hrs:

| Node ID | Demand LPS | Head m | Pressure m | Quality hours |
|---------|------------|--------|------------|---------------|
| J5 | 0.00 | 130.30 | 57.25 | 0.00 |
| J3 | 0.12 | 130.30 | 57.03 | 0.00 |
| J1 | 0.12 | 130.30 | 57.07 | 0.00 |
| J2 | 0.12 | 130.30 | 56.90 | 0.00 |
| J6 | 0.00 | 130.30 | 57.20 | 0.00 |
| J4 | 0.12 | 130.30 | 56.70 | 0.00 |
| J8 | 0.00 | 130.30 | 56.00 | 0.00 |
| J7 | 0.00 | 130.30 | 56.30 | 0.00 |
| FH2 | 0.00 | 130.30 | 56.50 | 0.00 |
| J9 | 0.12 | 130.30 | 55.80 | 0.00 |
| J10 | 0.12 | 130.30 | 55.95 | 0.00 |
| FH1 | 0.00 | 130.30 | 57.00 | 0.00 |

| | | | | | |
|-----|-------|--------|-------|------|-----------|
| J11 | 0.00 | 130.30 | 56.25 | 0.00 | |
| R1 | -0.38 | 130.30 | 0.00 | 0.00 | Reservoir |
| R2 | -0.33 | 130.30 | 0.00 | 0.00 | Reservoir |



Page 2

Link Results at 0:00 Hrs:

| Link ID | Flow LPS | Velocity m/s | Headloss m/km | Status |
|---------|----------|--------------|---------------|--------|
| P1 | -0.12 | 0.01 | 0.00 | Open |
| P4 | -0.38 | 0.01 | 0.00 | Open |
| P3 | 0.16 | 0.01 | 0.00 | Open |
| P2 | -0.12 | 0.01 | 0.00 | Open |
| P6 | 0.04 | 0.00 | 0.00 | Open |
| P7 | -0.07 | 0.00 | 0.00 | Open |
| P5 | 0.10 | 0.00 | 0.00 | Open |
| P8 | -0.09 | 0.00 | 0.00 | Open |
| P9 | 0.33 | 0.01 | 0.00 | Open |
| P12 | 0.00 | 0.00 | 0.00 | Open |
| P10 | 0.24 | 0.01 | 0.00 | Open |
| P11 | 0.12 | 0.01 | 0.00 | Open |
| P13 | 0.12 | 0.01 | 0.00 | Open |
| P14 | 0.00 | 0.00 | 0.00 | Open |
| P15 | 0.24 | 0.01 | 0.00 | Open |

Node Results at 1:00 Hrs:

| Node ID | Demand LPS | Head m | Pressure m | Quality hours |
|---------|------------|--------|------------|----------------|
| J5 | 0.00 | 130.30 | 57.25 | 0.23 |
| J3 | 0.12 | 130.30 | 57.03 | 1.00 |
| J1 | 0.12 | 130.30 | 57.07 | 1.00 |
| J2 | 0.12 | 130.30 | 56.90 | 1.00 |
| J6 | 0.00 | 130.30 | 57.20 | 1.00 |
| J4 | 0.12 | 130.30 | 56.70 | 1.00 |
| J8 | 0.00 | 130.30 | 56.00 | 1.00 |
| J7 | 0.00 | 130.30 | 56.30 | 0.41 |
| FH2 | 0.00 | 130.30 | 56.50 | 1.00 |
| J9 | 0.12 | 130.30 | 55.80 | 1.00 |
| J10 | 0.12 | 130.30 | 55.95 | 1.00 |
| FH1 | 0.00 | 130.30 | 57.00 | 1.00 |
| J11 | 0.00 | 130.30 | 56.25 | 1.00 |
| R1 | -0.38 | 130.30 | 0.00 | 0.00 Reservoir |
| R2 | -0.33 | 130.30 | 0.00 | 0.00 Reservoir |



Page 3

Link Results at 1:00 Hrs:

| Link ID | Flow LPS | Velocity m/s | Unit Headloss m/km | Status |
|---------|----------|--------------|--------------------|--------|
| P1 | -0.12 | 0.01 | 0.00 | Open |
| P4 | -0.38 | 0.01 | 0.00 | Open |
| P3 | 0.16 | 0.01 | 0.00 | Open |
| P2 | -0.12 | 0.01 | 0.00 | Open |
| P6 | 0.04 | 0.00 | 0.00 | Open |
| P7 | -0.07 | 0.00 | 0.00 | Open |
| P5 | 0.10 | 0.00 | 0.00 | Open |
| P8 | -0.09 | 0.00 | 0.00 | Open |
| P9 | 0.33 | 0.01 | 0.00 | Open |
| P12 | 0.00 | 0.00 | 0.00 | Open |
| P10 | 0.24 | 0.01 | 0.00 | Open |
| P11 | 0.12 | 0.01 | 0.00 | Open |
| P13 | 0.12 | 0.01 | 0.00 | Open |
| P14 | 0.00 | 0.00 | 0.00 | Open |
| P15 | 0.24 | 0.01 | 0.00 | Open |

Node Results at 2:00 Hrs:

| Node ID | Demand LPS | Head m | Pressure m | Quality hours |
|---------|------------|--------|------------|----------------|
| J5 | 0.00 | 130.30 | 57.25 | 0.23 |
| J3 | 0.12 | 130.30 | 57.03 | 2.00 |
| J1 | 0.12 | 130.30 | 57.07 | 2.00 |
| J2 | 0.12 | 130.30 | 56.90 | 2.00 |
| J6 | 0.00 | 130.30 | 57.20 | 1.71 |
| J4 | 0.12 | 130.30 | 56.70 | 2.00 |
| J8 | 0.00 | 130.30 | 56.00 | 1.08 |
| J7 | 0.00 | 130.30 | 56.30 | 0.41 |
| FH2 | 0.00 | 130.30 | 56.50 | 2.00 |
| J9 | 0.12 | 130.30 | 55.80 | 2.00 |
| J10 | 0.12 | 130.30 | 55.95 | 2.00 |
| FH1 | 0.00 | 130.30 | 57.00 | 2.00 |
| J11 | 0.00 | 130.30 | 56.25 | 1.00 |
| R1 | -0.38 | 130.30 | 0.00 | 0.00 Reservoir |
| R2 | -0.33 | 130.30 | 0.00 | 0.00 Reservoir |



Page 4

Link Results at 2:00 Hrs:

| Link | Flow | Velocity | Unit Headloss | Status |
|------|------|----------|---------------|--------|
|------|------|----------|---------------|--------|

| ID | LPS | m/s | m/km | |
|-----|-------|------|------|------|
| P1 | -0.12 | 0.01 | 0.00 | Open |
| P4 | -0.38 | 0.01 | 0.00 | Open |
| P3 | 0.16 | 0.01 | 0.00 | Open |
| P2 | -0.12 | 0.01 | 0.00 | Open |
| P6 | 0.04 | 0.00 | 0.00 | Open |
| P7 | -0.07 | 0.00 | 0.00 | Open |
| P5 | 0.10 | 0.00 | 0.00 | Open |
| P8 | -0.09 | 0.00 | 0.00 | Open |
| P9 | 0.33 | 0.01 | 0.00 | Open |
| P12 | 0.00 | 0.00 | 0.00 | Open |
| P10 | 0.24 | 0.01 | 0.00 | Open |
| P11 | 0.12 | 0.01 | 0.00 | Open |
| P13 | 0.12 | 0.01 | 0.00 | Open |
| P14 | 0.00 | 0.00 | 0.00 | Open |
| P15 | 0.24 | 0.01 | 0.00 | Open |

Node Results at 3:00 Hrs:

| Node ID | Demand LPS | Head m | Pressure m | Quality hours | |
|---------|------------|--------|------------|---------------|-----------|
| J5 | 0.00 | 130.30 | 57.25 | 0.23 | |
| J3 | 0.12 | 130.30 | 57.03 | 3.00 | |
| J1 | 0.12 | 130.30 | 57.07 | 2.44 | |
| J2 | 0.12 | 130.30 | 56.90 | 3.00 | |
| J6 | 0.00 | 130.30 | 57.20 | 1.71 | |
| J4 | 0.12 | 130.30 | 56.70 | 3.00 | |
| J8 | 0.00 | 130.30 | 56.00 | 1.08 | |
| J7 | 0.00 | 130.30 | 56.30 | 0.41 | |
| FH2 | 0.00 | 130.30 | 56.50 | 3.00 | |
| J9 | 0.12 | 130.30 | 55.80 | 3.00 | |
| J10 | 0.12 | 130.30 | 55.95 | 2.61 | |
| FH1 | 0.00 | 130.30 | 57.00 | 3.00 | |
| J11 | 0.00 | 130.30 | 56.25 | 1.00 | |
| R1 | -0.38 | 130.30 | 0.00 | 0.00 | Reservoir |
| R2 | -0.33 | 130.30 | 0.00 | 0.00 | Reservoir |



Link Results at 3:00 Hrs:

| Link ID | Flow LPS | Velocity m/s | Headloss m/km | Status |
|---------|----------|--------------|---------------|--------|
| P1 | -0.12 | 0.01 | 0.00 | Open |
| P4 | -0.38 | 0.01 | 0.00 | Open |
| P3 | 0.16 | 0.01 | 0.00 | Open |

| | | | | |
|-----|-------|------|------|------|
| P2 | -0.12 | 0.01 | 0.00 | Open |
| P6 | 0.04 | 0.00 | 0.00 | Open |
| P7 | -0.07 | 0.00 | 0.00 | Open |
| P5 | 0.10 | 0.00 | 0.00 | Open |
| P8 | -0.09 | 0.00 | 0.00 | Open |
| P9 | 0.33 | 0.01 | 0.00 | Open |
| P12 | 0.00 | 0.00 | 0.00 | Open |
| P10 | 0.24 | 0.01 | 0.00 | Open |
| P11 | 0.12 | 0.01 | 0.00 | Open |
| P13 | 0.12 | 0.01 | 0.00 | Open |
| P14 | 0.00 | 0.00 | 0.00 | Open |
| P15 | 0.24 | 0.01 | 0.00 | Open |

Node Results at 4:00 Hrs:

| Node ID | Demand LPS | Head m | Pressure m | Quality hours |
|---------|------------|--------|------------|----------------|
| J5 | 0.00 | 130.30 | 57.25 | 0.23 |
| J3 | 0.12 | 130.30 | 57.03 | 4.00 |
| J1 | 0.12 | 130.30 | 57.07 | 2.44 |
| J2 | 0.12 | 130.30 | 56.90 | 3.96 |
| J6 | 0.00 | 130.30 | 57.20 | 1.71 |
| J4 | 0.12 | 130.30 | 56.70 | 4.00 |
| J8 | 0.00 | 130.30 | 56.00 | 1.08 |
| J7 | 0.00 | 130.30 | 56.30 | 0.41 |
| FH2 | 0.00 | 130.30 | 56.50 | 4.00 |
| J9 | 0.12 | 130.30 | 55.80 | 3.87 |
| J10 | 0.12 | 130.30 | 55.95 | 2.61 |
| FH1 | 0.00 | 130.30 | 57.00 | 4.00 |
| J11 | 0.00 | 130.30 | 56.25 | 1.00 |
| R1 | -0.38 | 130.30 | 0.00 | 0.00 Reservoir |
| R2 | -0.33 | 130.30 | 0.00 | 0.00 Reservoir |



Page 6

Link Results at 4:00 Hrs:

| Link ID | Flow LPS | Velocity m/s | Unit Headloss m/km | Status |
|---------|----------|--------------|--------------------|--------|
| P1 | -0.12 | 0.01 | 0.00 | Open |
| P4 | -0.38 | 0.01 | 0.00 | Open |
| P3 | 0.16 | 0.01 | 0.00 | Open |
| P2 | -0.12 | 0.01 | 0.00 | Open |
| P6 | 0.04 | 0.00 | 0.00 | Open |
| P7 | -0.07 | 0.00 | 0.00 | Open |
| P5 | 0.10 | 0.00 | 0.00 | Open |
| P8 | -0.09 | 0.00 | 0.00 | Open |

| | | | | |
|-----|------|------|------|------|
| P9 | 0.33 | 0.01 | 0.00 | Open |
| P12 | 0.00 | 0.00 | 0.00 | Open |
| P10 | 0.24 | 0.01 | 0.00 | Open |
| P11 | 0.12 | 0.01 | 0.00 | Open |
| P13 | 0.12 | 0.01 | 0.00 | Open |
| P14 | 0.00 | 0.00 | 0.00 | Open |
| P15 | 0.24 | 0.01 | 0.00 | Open |

Node Results at 5:00 Hrs:

| Node ID | Demand LPS | Head m | Pressure m | Quality hours |
|---------|------------|--------|------------|----------------|
| J5 | 0.00 | 130.30 | 57.25 | 0.23 |
| J3 | 0.12 | 130.30 | 57.03 | 4.92 |
| J1 | 0.12 | 130.30 | 57.07 | 2.44 |
| J2 | 0.12 | 130.30 | 56.90 | 3.97 |
| J6 | 0.00 | 130.30 | 57.20 | 1.71 |
| J4 | 0.12 | 130.30 | 56.70 | 5.00 |
| J8 | 0.00 | 130.30 | 56.00 | 1.08 |
| J7 | 0.00 | 130.30 | 56.30 | 0.41 |
| FH2 | 0.00 | 130.30 | 56.50 | 5.00 |
| J9 | 0.12 | 130.30 | 55.80 | 3.87 |
| J10 | 0.12 | 130.30 | 55.95 | 2.61 |
| FH1 | 0.00 | 130.30 | 57.00 | 5.00 |
| J11 | 0.00 | 130.30 | 56.25 | 1.00 |
| R1 | -0.38 | 130.30 | 0.00 | 0.00 Reservoir |
| R2 | -0.33 | 130.30 | 0.00 | 0.00 Reservoir |



Link Results at 5:00 Hrs:

| Link ID | Flow LPS | Velocity m/s | Unit Headloss m/km | Status |
|---------|----------|--------------|--------------------|--------|
| P1 | -0.12 | 0.01 | 0.00 | Open |
| P4 | -0.38 | 0.01 | 0.00 | Open |
| P3 | 0.16 | 0.01 | 0.00 | Open |
| P2 | -0.12 | 0.01 | 0.00 | Open |
| P6 | 0.04 | 0.00 | 0.00 | Open |
| P7 | -0.07 | 0.00 | 0.00 | Open |
| P5 | 0.10 | 0.00 | 0.00 | Open |
| P8 | -0.09 | 0.00 | 0.00 | Open |
| P9 | 0.33 | 0.01 | 0.00 | Open |
| P12 | 0.00 | 0.00 | 0.00 | Open |
| P10 | 0.24 | 0.01 | 0.00 | Open |
| P11 | 0.12 | 0.01 | 0.00 | Open |
| P13 | 0.12 | 0.01 | 0.00 | Open |

| | | | | |
|-----|------|------|------|------|
| P14 | 0.00 | 0.00 | 0.00 | Open |
| P15 | 0.24 | 0.01 | 0.00 | Open |

Node Results at 6:00 Hrs:

| Node ID | Demand LPS | Head m | Pressure m | Quality hours |
|---------|------------|--------|------------|----------------|
| J5 | 0.00 | 130.30 | 57.25 | 0.23 |
| J3 | 0.12 | 130.30 | 57.03 | 5.31 |
| J1 | 0.12 | 130.30 | 57.07 | 2.44 |
| J2 | 0.12 | 130.30 | 56.90 | 3.97 |
| J6 | 0.00 | 130.30 | 57.20 | 1.71 |
| J4 | 0.12 | 130.30 | 56.70 | 6.00 |
| J8 | 0.00 | 130.30 | 56.00 | 1.08 |
| J7 | 0.00 | 130.30 | 56.30 | 0.41 |
| FH2 | 0.00 | 130.30 | 56.50 | 6.00 |
| J9 | 0.12 | 130.30 | 55.80 | 3.87 |
| J10 | 0.12 | 130.30 | 55.95 | 2.61 |
| FH1 | 0.00 | 130.30 | 57.00 | 6.00 |
| J11 | 0.00 | 130.30 | 56.25 | 1.00 |
| R1 | -0.38 | 130.30 | 0.00 | 0.00 Reservoir |
| R2 | -0.33 | 130.30 | 0.00 | 0.00 Reservoir |



Page 8

Link Results at 6:00 Hrs:

| Link ID | Flow LPS | Velocity m/s | Headloss m/km | Status |
|---------|----------|--------------|---------------|--------|
| P1 | -0.12 | 0.01 | 0.00 | Open |
| P4 | -0.38 | 0.01 | 0.00 | Open |
| P3 | 0.16 | 0.01 | 0.00 | Open |
| P2 | -0.12 | 0.01 | 0.00 | Open |
| P6 | 0.04 | 0.00 | 0.00 | Open |
| P7 | -0.07 | 0.00 | 0.00 | Open |
| P5 | 0.10 | 0.00 | 0.00 | Open |
| P8 | -0.09 | 0.00 | 0.00 | Open |
| P9 | 0.33 | 0.01 | 0.00 | Open |
| P12 | 0.00 | 0.00 | 0.00 | Open |
| P10 | 0.24 | 0.01 | 0.00 | Open |
| P11 | 0.12 | 0.01 | 0.00 | Open |
| P13 | 0.12 | 0.01 | 0.00 | Open |
| P14 | 0.00 | 0.00 | 0.00 | Open |
| P15 | 0.24 | 0.01 | 0.00 | Open |

Node Results at 7:00 Hrs:

| Node ID | Demand LPS | Head m | Pressure m | Quality hours |
|---------|------------|--------|------------|----------------|
| J5 | 0.00 | 130.30 | 57.25 | 0.23 |
| J3 | 0.12 | 130.30 | 57.03 | 5.31 |
| J1 | 0.12 | 130.30 | 57.07 | 2.44 |
| J2 | 0.12 | 130.30 | 56.90 | 3.97 |
| J6 | 0.00 | 130.30 | 57.20 | 1.71 |
| J4 | 0.12 | 130.30 | 56.70 | 6.68 |
| J8 | 0.00 | 130.30 | 56.00 | 1.08 |
| J7 | 0.00 | 130.30 | 56.30 | 0.41 |
| FH2 | 0.00 | 130.30 | 56.50 | 7.00 |
| J9 | 0.12 | 130.30 | 55.80 | 3.87 |
| J10 | 0.12 | 130.30 | 55.95 | 2.61 |
| FH1 | 0.00 | 130.30 | 57.00 | 7.00 |
| J11 | 0.00 | 130.30 | 56.25 | 1.00 |
| R1 | -0.38 | 130.30 | 0.00 | 0.00 Reservoir |
| R2 | -0.33 | 130.30 | 0.00 | 0.00 Reservoir |



Page 9

Link Results at 7:00 Hrs:

| Link ID | Flow LPS | Velocity m/s | Unit Headloss m/km | Status |
|---------|----------|--------------|--------------------|--------|
| P1 | -0.12 | 0.01 | 0.00 | Open |
| P4 | -0.38 | 0.01 | 0.00 | Open |
| P3 | 0.16 | 0.01 | 0.00 | Open |
| P2 | -0.12 | 0.01 | 0.00 | Open |
| P6 | 0.04 | 0.00 | 0.00 | Open |
| P7 | -0.07 | 0.00 | 0.00 | Open |
| P5 | 0.10 | 0.00 | 0.00 | Open |
| P8 | -0.09 | 0.00 | 0.00 | Open |
| P9 | 0.33 | 0.01 | 0.00 | Open |
| P12 | 0.00 | 0.00 | 0.00 | Open |
| P10 | 0.24 | 0.01 | 0.00 | Open |
| P11 | 0.12 | 0.01 | 0.00 | Open |
| P13 | 0.12 | 0.01 | 0.00 | Open |
| P14 | 0.00 | 0.00 | 0.00 | Open |
| P15 | 0.24 | 0.01 | 0.00 | Open |

Node Results at 8:00 Hrs:

| Node ID | Demand LPS | Head m | Pressure m | Quality hours |
|---------|------------|--------|------------|---------------|
| J5 | 0.00 | 130.30 | 57.25 | 0.23 |
| J3 | 0.12 | 130.30 | 57.03 | 5.31 |

| | | | | | |
|-----|-------|--------|-------|------|-----------|
| J1 | 0.12 | 130.30 | 57.07 | 2.44 | |
| J2 | 0.12 | 130.30 | 56.90 | 3.97 | |
| J6 | 0.00 | 130.30 | 57.20 | 1.71 | |
| J4 | 0.12 | 130.30 | 56.70 | 6.75 | |
| J8 | 0.00 | 130.30 | 56.00 | 1.08 | |
| J7 | 0.00 | 130.30 | 56.30 | 0.41 | |
| FH2 | 0.00 | 130.30 | 56.50 | 8.00 | |
| J9 | 0.12 | 130.30 | 55.80 | 3.87 | |
| J10 | 0.12 | 130.30 | 55.95 | 2.61 | |
| FH1 | 0.00 | 130.30 | 57.00 | 8.00 | |
| J11 | 0.00 | 130.30 | 56.25 | 1.00 | |
| R1 | -0.38 | 130.30 | 0.00 | 0.00 | Reservoir |
| R2 | -0.33 | 130.30 | 0.00 | 0.00 | Reservoir |



Page 10

Link Results at 8:00 Hrs:

| Link ID | Flow LPS | Velocity m/s | Unit Headloss m/km | Status |
|---------|----------|--------------|--------------------|--------|
| P1 | -0.12 | 0.01 | 0.00 | Open |
| P4 | -0.38 | 0.01 | 0.00 | Open |
| P3 | 0.16 | 0.01 | 0.00 | Open |
| P2 | -0.12 | 0.01 | 0.00 | Open |
| P6 | 0.04 | 0.00 | 0.00 | Open |
| P7 | -0.07 | 0.00 | 0.00 | Open |
| P5 | 0.10 | 0.00 | 0.00 | Open |
| P8 | -0.09 | 0.00 | 0.00 | Open |
| P9 | 0.33 | 0.01 | 0.00 | Open |
| P12 | 0.00 | 0.00 | 0.00 | Open |
| P10 | 0.24 | 0.01 | 0.00 | Open |
| P11 | 0.12 | 0.01 | 0.00 | Open |
| P13 | 0.12 | 0.01 | 0.00 | Open |
| P14 | 0.00 | 0.00 | 0.00 | Open |
| P15 | 0.24 | 0.01 | 0.00 | Open |

Node Results at 9:00 Hrs:

| Node ID | Demand LPS | Head m | Pressure m | Quality hours |
|---------|------------|--------|------------|---------------|
| J5 | 0.00 | 130.30 | 57.25 | 0.23 |
| J3 | 0.12 | 130.30 | 57.03 | 5.31 |
| J1 | 0.12 | 130.30 | 57.07 | 2.44 |
| J2 | 0.12 | 130.30 | 56.90 | 3.97 |
| J6 | 0.00 | 130.30 | 57.20 | 1.71 |
| J4 | 0.12 | 130.30 | 56.70 | 6.75 |
| J8 | 0.00 | 130.30 | 56.00 | 1.08 |

| | | | | | |
|-----|-------|--------|-------|------|-----------|
| J7 | 0.00 | 130.30 | 56.30 | 0.41 | |
| FH2 | 0.00 | 130.30 | 56.50 | 9.00 | |
| J9 | 0.12 | 130.30 | 55.80 | 3.87 | |
| J10 | 0.12 | 130.30 | 55.95 | 2.61 | |
| FH1 | 0.00 | 130.30 | 57.00 | 9.00 | |
| J11 | 0.00 | 130.30 | 56.25 | 1.00 | |
| R1 | -0.38 | 130.30 | 0.00 | 0.00 | Reservoir |
| R2 | -0.33 | 130.30 | 0.00 | 0.00 | Reservoir |



Page 11

Link Results at 9:00 Hrs:

| Link ID | Flow LPS | Velocity m/s | Unit Headloss m/km | Status |
|---------|----------|--------------|--------------------|--------|
| P1 | -0.12 | 0.01 | 0.00 | Open |
| P4 | -0.38 | 0.01 | 0.00 | Open |
| P3 | 0.16 | 0.01 | 0.00 | Open |
| P2 | -0.12 | 0.01 | 0.00 | Open |
| P6 | 0.04 | 0.00 | 0.00 | Open |
| P7 | -0.07 | 0.00 | 0.00 | Open |
| P5 | 0.10 | 0.00 | 0.00 | Open |
| P8 | -0.09 | 0.00 | 0.00 | Open |
| P9 | 0.33 | 0.01 | 0.00 | Open |
| P12 | 0.00 | 0.00 | 0.00 | Open |
| P10 | 0.24 | 0.01 | 0.00 | Open |
| P11 | 0.12 | 0.01 | 0.00 | Open |
| P13 | 0.12 | 0.01 | 0.00 | Open |
| P14 | 0.00 | 0.00 | 0.00 | Open |
| P15 | 0.24 | 0.01 | 0.00 | Open |

Node Results at 10:00 Hrs:

| Node ID | Demand LPS | Head m | Pressure m | Quality hours |
|---------|------------|--------|------------|---------------|
| J5 | 0.00 | 130.30 | 57.25 | 0.23 |
| J3 | 0.12 | 130.30 | 57.03 | 5.31 |
| J1 | 0.12 | 130.30 | 57.07 | 2.44 |
| J2 | 0.12 | 130.30 | 56.90 | 3.97 |
| J6 | 0.00 | 130.30 | 57.20 | 1.71 |
| J4 | 0.12 | 130.30 | 56.70 | 6.75 |
| J8 | 0.00 | 130.30 | 56.00 | 1.08 |
| J7 | 0.00 | 130.30 | 56.30 | 0.41 |
| FH2 | 0.00 | 130.30 | 56.50 | 10.00 |
| J9 | 0.12 | 130.30 | 55.80 | 3.87 |
| J10 | 0.12 | 130.30 | 55.95 | 2.61 |
| FH1 | 0.00 | 130.30 | 57.00 | 10.00 |

| | | | | | |
|-----|-------|--------|-------|------|-----------|
| J11 | 0.00 | 130.30 | 56.25 | 1.00 | |
| R1 | -0.38 | 130.30 | 0.00 | 0.00 | Reservoir |
| R2 | -0.33 | 130.30 | 0.00 | 0.00 | Reservoir |



Page 12

Link Results at 10:00 Hrs:

| Link ID | Flow LPS | Velocity m/s | Headloss m/km | Status |
|---------|----------|--------------|---------------|--------|
| P1 | -0.12 | 0.01 | 0.00 | Open |
| P4 | -0.38 | 0.01 | 0.00 | Open |
| P3 | 0.16 | 0.01 | 0.00 | Open |
| P2 | -0.12 | 0.01 | 0.00 | Open |
| P6 | 0.04 | 0.00 | 0.00 | Open |
| P7 | -0.07 | 0.00 | 0.00 | Open |
| P5 | 0.10 | 0.00 | 0.00 | Open |
| P8 | -0.09 | 0.00 | 0.00 | Open |
| P9 | 0.33 | 0.01 | 0.00 | Open |
| P12 | 0.00 | 0.00 | 0.00 | Open |
| P10 | 0.24 | 0.01 | 0.00 | Open |
| P11 | 0.12 | 0.01 | 0.00 | Open |
| P13 | 0.12 | 0.01 | 0.00 | Open |
| P14 | 0.00 | 0.00 | 0.00 | Open |
| P15 | 0.24 | 0.01 | 0.00 | Open |

Node Results at 11:00 Hrs:

| Node ID | Demand LPS | Head m | Pressure m | Quality hours |
|---------|------------|--------|------------|----------------|
| J5 | 0.00 | 130.30 | 57.25 | 0.23 |
| J3 | 0.12 | 130.30 | 57.03 | 5.31 |
| J1 | 0.12 | 130.30 | 57.07 | 2.44 |
| J2 | 0.12 | 130.30 | 56.90 | 3.97 |
| J6 | 0.00 | 130.30 | 57.20 | 1.71 |
| J4 | 0.12 | 130.30 | 56.70 | 6.75 |
| J8 | 0.00 | 130.30 | 56.00 | 1.08 |
| J7 | 0.00 | 130.30 | 56.30 | 0.41 |
| FH2 | 0.00 | 130.30 | 56.50 | 11.00 |
| J9 | 0.12 | 130.30 | 55.80 | 3.87 |
| J10 | 0.12 | 130.30 | 55.95 | 2.61 |
| FH1 | 0.00 | 130.30 | 57.00 | 11.00 |
| J11 | 0.00 | 130.30 | 56.25 | 1.00 |
| R1 | -0.38 | 130.30 | 0.00 | 0.00 Reservoir |
| R2 | -0.33 | 130.30 | 0.00 | 0.00 Reservoir |



Page 13

Link Results at 11:00 Hrs:

| Link ID | Flow LPS | Velocity m/s | Unit Headloss m/km | Status |
|---------|----------|--------------|--------------------|--------|
| P1 | -0.12 | 0.01 | 0.00 | Open |
| P4 | -0.38 | 0.01 | 0.00 | Open |
| P3 | 0.16 | 0.01 | 0.00 | Open |
| P2 | -0.12 | 0.01 | 0.00 | Open |
| P6 | 0.04 | 0.00 | 0.00 | Open |
| P7 | -0.07 | 0.00 | 0.00 | Open |
| P5 | 0.10 | 0.00 | 0.00 | Open |
| P8 | -0.09 | 0.00 | 0.00 | Open |
| P9 | 0.33 | 0.01 | 0.00 | Open |
| P12 | 0.00 | 0.00 | 0.00 | Open |
| P10 | 0.24 | 0.01 | 0.00 | Open |
| P11 | 0.12 | 0.01 | 0.00 | Open |
| P13 | 0.12 | 0.01 | 0.00 | Open |
| P14 | 0.00 | 0.00 | 0.00 | Open |
| P15 | 0.24 | 0.01 | 0.00 | Open |

Node Results at 12:00 Hrs:

| Node ID | Demand LPS | Head m | Pressure m | Quality hours |
|---------|------------|--------|------------|----------------|
| J5 | 0.00 | 130.30 | 57.25 | 0.23 |
| J3 | 0.12 | 130.30 | 57.03 | 5.31 |
| J1 | 0.12 | 130.30 | 57.07 | 2.44 |
| J2 | 0.12 | 130.30 | 56.90 | 3.97 |
| J6 | 0.00 | 130.30 | 57.20 | 1.71 |
| J4 | 0.12 | 130.30 | 56.70 | 6.75 |
| J8 | 0.00 | 130.30 | 56.00 | 1.08 |
| J7 | 0.00 | 130.30 | 56.30 | 0.41 |
| FH2 | 0.00 | 130.30 | 56.50 | 12.00 |
| J9 | 0.12 | 130.30 | 55.80 | 3.87 |
| J10 | 0.12 | 130.30 | 55.95 | 2.61 |
| FH1 | 0.00 | 130.30 | 57.00 | 12.00 |
| J11 | 0.00 | 130.30 | 56.25 | 1.00 |
| R1 | -0.38 | 130.30 | 0.00 | 0.00 Reservoir |
| R2 | -0.33 | 130.30 | 0.00 | 0.00 Reservoir |



Page 14

Link Results at 12:00 Hrs:

| Link | Flow | Velocity | Unit Headloss | Status |
|------|------|----------|---------------|--------|
|------|------|----------|---------------|--------|

| Node ID | Demand LPS | Head m | Pressure m | Quality hours |
|---------|------------|--------|------------|----------------|
| J5 | 0.00 | 130.30 | 57.25 | 0.23 |
| J3 | 0.12 | 130.30 | 57.03 | 5.31 |
| J1 | 0.12 | 130.30 | 57.07 | 2.44 |
| J2 | 0.12 | 130.30 | 56.90 | 3.97 |
| J6 | 0.00 | 130.30 | 57.20 | 1.71 |
| J4 | 0.12 | 130.30 | 56.70 | 6.75 |
| J8 | 0.00 | 130.30 | 56.00 | 1.09 |
| J7 | 0.00 | 130.30 | 56.30 | 0.41 |
| FH2 | 0.00 | 130.30 | 56.50 | 117.00 |
| J9 | 0.12 | 130.30 | 55.80 | 3.87 |
| J10 | 0.12 | 130.30 | 55.95 | 2.61 |
| FH1 | 0.00 | 130.30 | 57.00 | 117.00 |
| J11 | 0.00 | 130.30 | 56.25 | 1.01 |
| R1 | -0.38 | 130.30 | 0.00 | 0.00 Reservoir |
| R2 | -0.33 | 130.30 | 0.00 | 0.00 Reservoir |



Page 119

Link Results at 117:00 Hrs:

| Link ID | Flow LPS | Velocity m/s | Unit Headloss m/km | Status |
|---------|----------|--------------|--------------------|--------|
| P1 | -0.12 | 0.01 | 0.00 | Open |
| P4 | -0.38 | 0.01 | 0.00 | Open |
| P3 | 0.16 | 0.01 | 0.00 | Open |
| P2 | -0.12 | 0.01 | 0.00 | Open |
| P6 | 0.04 | 0.00 | 0.00 | Open |
| P7 | -0.07 | 0.00 | 0.00 | Open |
| P5 | 0.10 | 0.00 | 0.00 | Open |
| P8 | -0.09 | 0.00 | 0.00 | Open |
| P9 | 0.33 | 0.01 | 0.00 | Open |
| P12 | 0.00 | 0.00 | 0.00 | Open |
| P10 | 0.24 | 0.01 | 0.00 | Open |
| P11 | 0.12 | 0.01 | 0.00 | Open |
| P13 | 0.12 | 0.01 | 0.00 | Open |
| P14 | 0.00 | 0.00 | 0.00 | Open |
| P15 | 0.24 | 0.01 | 0.00 | Open |

Node Results at 118:00 Hrs:

| Node ID | Demand LPS | Head m | Pressure m | Quality hours |
|---------|------------|--------|------------|---------------|
| J5 | 0.00 | 130.30 | 57.25 | 0.23 |
| J3 | 0.12 | 130.30 | 57.03 | 5.31 |

| | | | | | |
|-----|-------|--------|-------|--------|-----------|
| J1 | 0.12 | 130.30 | 57.07 | 2.44 | |
| J2 | 0.12 | 130.30 | 56.90 | 3.97 | |
| J6 | 0.00 | 130.30 | 57.20 | 1.71 | |
| J4 | 0.12 | 130.30 | 56.70 | 6.75 | |
| J8 | 0.00 | 130.30 | 56.00 | 1.08 | |
| J7 | 0.00 | 130.30 | 56.30 | 0.41 | |
| FH2 | 0.00 | 130.30 | 56.50 | 118.00 | |
| J9 | 0.12 | 130.30 | 55.80 | 3.87 | |
| J10 | 0.12 | 130.30 | 55.95 | 2.62 | |
| FH1 | 0.00 | 130.30 | 57.00 | 118.00 | |
| J11 | 0.00 | 130.30 | 56.25 | 1.00 | |
| R1 | -0.38 | 130.30 | 0.00 | 0.00 | Reservoir |
| R2 | -0.33 | 130.30 | 0.00 | 0.00 | Reservoir |



Page 120

Link Results at 118:00 Hrs:

| Link ID | Flow LPS | Velocity m/s | Unit Headloss m/km | Status |
|---------|----------|--------------|--------------------|--------|
| P1 | -0.12 | 0.01 | 0.00 | Open |
| P4 | -0.38 | 0.01 | 0.00 | Open |
| P3 | 0.16 | 0.01 | 0.00 | Open |
| P2 | -0.12 | 0.01 | 0.00 | Open |
| P6 | 0.04 | 0.00 | 0.00 | Open |
| P7 | -0.07 | 0.00 | 0.00 | Open |
| P5 | 0.10 | 0.00 | 0.00 | Open |
| P8 | -0.09 | 0.00 | 0.00 | Open |
| P9 | 0.33 | 0.01 | 0.00 | Open |
| P12 | 0.00 | 0.00 | 0.00 | Open |
| P10 | 0.24 | 0.01 | 0.00 | Open |
| P11 | 0.12 | 0.01 | 0.00 | Open |
| P13 | 0.12 | 0.01 | 0.00 | Open |
| P14 | 0.00 | 0.00 | 0.00 | Open |
| P15 | 0.24 | 0.01 | 0.00 | Open |

Node Results at 119:00 Hrs:

| Node ID | Demand LPS | Head m | Pressure m | Quality hours |
|---------|------------|--------|------------|---------------|
| J5 | 0.00 | 130.30 | 57.25 | 0.23 |
| J3 | 0.12 | 130.30 | 57.03 | 5.31 |
| J1 | 0.12 | 130.30 | 57.07 | 2.44 |
| J2 | 0.12 | 130.30 | 56.90 | 3.97 |
| J6 | 0.00 | 130.30 | 57.20 | 1.72 |
| J4 | 0.12 | 130.30 | 56.70 | 6.75 |
| J8 | 0.00 | 130.30 | 56.00 | 1.09 |

| | | | | | |
|-----|-------|--------|-------|--------|-----------|
| J7 | 0.00 | 130.30 | 56.30 | 0.41 | |
| FH2 | 0.00 | 130.30 | 56.50 | 119.00 | |
| J9 | 0.12 | 130.30 | 55.80 | 3.89 | |
| J10 | 0.12 | 130.30 | 55.95 | 2.61 | |
| FH1 | 0.00 | 130.30 | 57.00 | 119.00 | |
| J11 | 0.00 | 130.30 | 56.25 | 1.01 | |
| R1 | -0.38 | 130.30 | 0.00 | 0.00 | Reservoir |
| R2 | -0.33 | 130.30 | 0.00 | 0.00 | Reservoir |



Page 121

Link Results at 119:00 Hrs:

| Link ID | Flow LPS | Velocity m/s | Unit Headloss m/km | Status |
|---------|----------|--------------|--------------------|--------|
| P1 | -0.12 | 0.01 | 0.00 | Open |
| P4 | -0.38 | 0.01 | 0.00 | Open |
| P3 | 0.16 | 0.01 | 0.00 | Open |
| P2 | -0.12 | 0.01 | 0.00 | Open |
| P6 | 0.04 | 0.00 | 0.00 | Open |
| P7 | -0.07 | 0.00 | 0.00 | Open |
| P5 | 0.10 | 0.00 | 0.00 | Open |
| P8 | -0.09 | 0.00 | 0.00 | Open |
| P9 | 0.33 | 0.01 | 0.00 | Open |
| P12 | 0.00 | 0.00 | 0.00 | Open |
| P10 | 0.24 | 0.01 | 0.00 | Open |
| P11 | 0.12 | 0.01 | 0.00 | Open |
| P13 | 0.12 | 0.01 | 0.00 | Open |
| P14 | 0.00 | 0.00 | 0.00 | Open |
| P15 | 0.24 | 0.01 | 0.00 | Open |

Node Results at 120:00 Hrs:

| Node ID | Demand LPS | Head m | Pressure m | Quality hours |
|---------|------------|--------|------------|---------------|
| J5 | 0.00 | 130.30 | 57.25 | 0.23 |
| J3 | 0.12 | 130.30 | 57.03 | 5.31 |
| J1 | 0.12 | 130.30 | 57.07 | 2.44 |
| J2 | 0.12 | 130.30 | 56.90 | 3.97 |
| J6 | 0.00 | 130.30 | 57.20 | 1.71 |
| J4 | 0.12 | 130.30 | 56.70 | 6.75 |
| J8 | 0.00 | 130.30 | 56.00 | 1.08 |
| J7 | 0.00 | 130.30 | 56.30 | 0.41 |
| FH2 | 0.00 | 130.30 | 56.50 | 120.00 |
| J9 | 0.12 | 130.30 | 55.80 | 3.87 |
| J10 | 0.12 | 130.30 | 55.95 | 2.62 |
| FH1 | 0.00 | 130.30 | 57.00 | 120.00 |

| | | | | | |
|-----|-------|--------|-------|------|-----------|
| J11 | 0.00 | 130.30 | 56.25 | 1.00 | |
| R1 | -0.38 | 130.30 | 0.00 | 0.00 | Reservoir |
| R2 | -0.33 | 130.30 | 0.00 | 0.00 | Reservoir |



Page 122

Link Results at 120:00 Hrs:

| Link ID | Flow LPS | Velocity m/s | Unit Headloss m/km | Status |
|---------|----------|--------------|--------------------|--------|
| P1 | -0.12 | 0.01 | 0.00 | Open |
| P4 | -0.38 | 0.01 | 0.00 | Open |
| P3 | 0.16 | 0.01 | 0.00 | Open |
| P2 | -0.12 | 0.01 | 0.00 | Open |
| P6 | 0.04 | 0.00 | 0.00 | Open |
| P7 | -0.07 | 0.00 | 0.00 | Open |
| P5 | 0.10 | 0.00 | 0.00 | Open |
| P8 | -0.09 | 0.00 | 0.00 | Open |
| P9 | 0.33 | 0.01 | 0.00 | Open |
| P12 | 0.00 | 0.00 | 0.00 | Open |
| P10 | 0.24 | 0.01 | 0.00 | Open |
| P11 | 0.12 | 0.01 | 0.00 | Open |
| P13 | 0.12 | 0.01 | 0.00 | Open |
| P14 | 0.00 | 0.00 | 0.00 | Open |
| P15 | 0.24 | 0.01 | 0.00 | Open |

APPENDIX D
SANITARY CALCULATIONS



000-22-1241 - 2025 Othello Avenue - Sanitary Demands

| | |
|--------------|---------------------|
| Project: | 2025 Othello Avenue |
| Project No.: | 000-22-1241 |
| Designed By: | RP |
| Checked By: | AG |
| Date: | December 12, 2025 |

| | | | |
|------------------|------|----------|--------------------------------|
| Ste Area | 1.11 | Gross ha | * Excluding ex. Building areas |
| 1 Bedroom | | | 1.40 Persons per unit |
| 2 Bedroom | 48 | | 2.10 Persons per unit |
| 3 Bedroom | 24 | | 3.10 Persons per unit |
| Total Population | | | 176 |

DESIGN PARAMETERS

| | | |
|--|-------|--|
| Institutional/ Commercial Peaking Factor | 1 | |
| Residential Peaking Factor | 3.53 | * Using Harmon Formula = $1+(14/(4+P^{0.5}))^{0.8}$ where P = population in thousands, Harmon's Correction Factor = 0.8 |
| Mannings coefficient (n) | 0.013 | |
| Demand (per capita) | 280 | L/day |
| Infiltration allowance | 0.33 | L/s/Ha |

EXTRANEIOUS FLOW ALLOWANCES

| Infiltration / Inflow | Flow (L/s) |
|-----------------------|------------|
| Dry | 0.06 |
| Wet | 0.31 |
| Total | 0.37 |

AVERAGE DAILY DEMAND

| DEMAND TYPE | AMOUNT | UNITS | POPULATION / AREA | Flow (L/s) |
|----------------------------|--------|---------------------------|-------------------|------------|
| Residential | 280 | L/c/d | 176 | 0.57 |
| Industrial - Light** | 35,000 | L/gross ha/d | | 0 |
| Industrial - Heavy** | 55,000 | L/gross ha/d | | 0 |
| Commercial / Amenity | 2,800 | L/(1000m ² /d) | | 0 |
| Restaurant | 125 | L/(9.2m ² /d) | | 0 |
| Schools | 70 | L/(Student/d) | | 0 |
| Trailer Parks no Hook-Ups | 340 | L/(space/d) | | 0 |
| Trailer Park with Hook-Ups | 800 | L/(space/d) | | 0 |
| Campgrounds | 225 | L/(campsite/d) | | 0 |
| Mobile Home Parks | 1,000 | L/(Space/d) | | 0 |
| Motels | 150 | L/(bed-space/d) | | 0 |
| Hotels | 225 | L/(bed-space/d) | | 0 |
| Office | 75 | L/7.0m ² /d | | 0 |
| Tourist Commercial | 28,000 | L/gross ha/d | | 0 |
| Other Commercial | 28,000 | L/gross ha/d | | 0 |

| | | |
|-------------------------------------|------|-----|
| AVERAGE RESIDENTIAL FLOW | 0.57 | L/s |
| PEAK RESIDENTIAL FLOW | 2.02 | L/s |
| AVERAGE ICI FLOW | 0.00 | L/s |
| PEAK INSTITUTIONAL/ COMMERCIAL FLOW | 0.00 | L/s |
| PEAK INDUSTRIAL FLOW | 0.00 | L/s |
| TOTAL PEAK ICI FLOW | 0.00 | L/s |

TOTAL SANITARY DEMAND

| | | |
|--|------|-----|
| TOTAL ESTIMATED AVERAGE DRY WEATHER FLOW | 0.63 | L/s |
| TOTAL ESTIMATED PEAK DRY WEATHER FLOW | 2.07 | L/s |
| TOTAL ESTIMATED PEAK WET WEATHER FLOW | 2.44 | L/s |

SANITARY SEWER DESIGN SHEET



PROJECT: CCO-22-1241
 LOCATION: 2025 Othello Avenue
 CLIENT: Osgoode Properties

| LOCATION | | | | RESIDENTIAL | | | | | | | | INFILTRATION ALLOWANCE | | | FLOW | | SEWER DATA | | | | | | |
|--|---------|---------|--------|--|-----|----|-----|-----------|------------|-------|-------------|--------------------------|-----------|------|-------------------|-------------------|----------------|---------------------|----------|-----------|-----------------------|--------------------|-------|
| 1 | 2 | 3 | 4 | 5 | 6 | 7 | 8 | 9 | 10 | 11 | 12 | 13 | 21 | 22 | 23 | 24 | 25 | 26 | 27 | 28 | 29 | 30 | 31 |
| STREET | AREA ID | FROM MH | TO MH | UNIT TYPES | | | | AREA (ha) | POPULATION | | PEAK FACTOR | PEAK FLOW (L/s) | AREA (ha) | | FLOW (L/s) | DESIGN FLOW (L/s) | CAPACITY (L/s) | LENGTH (m) | DIA (mm) | SLOPE (%) | VELOCITY (full) (m/s) | AVAILABLE CAPACITY | |
| | | | | 2BD | 3BD | TH | APT | | IND | CUM | | | IND | CUM | | | | | | | | L/s | (%) |
| WEST BLOCKS | | MHSA9 | MHSA4 | 8 | 4 | | | 0.14 | 29.2 | 29.2 | 3.53 | 0.33 | 0.14 | 0.14 | 0.05 | 0.38 | 31.55 | 46.72 | 200 | 0.85 | 0.973 | 31.17 | 98.79 |
| WEST BLOCKS | | MHSA1 | MHSA4 | 8 | 4 | | | 0.20 | 29.2 | 29.2 | 3.53 | 0.33 | 0.20 | 0.20 | 0.06 | 0.40 | 34.05 | 52.57 | 200 | 0.99 | 1.050 | 33.65 | 98.83 |
| WEST BLOCKS | | MHSA10 | MHSA6 | 8 | 4 | | | 0.14 | 29.2 | 29.2 | 3.53 | 0.33 | 0.14 | 0.14 | 0.05 | 0.38 | 34.39 | 42.54 | 200 | 1.01 | 1.060 | 34.01 | 98.89 |
| WEST BLOCKS | | MHSA6 | MHSA5 | | | | | | 29.2 | 29.2 | 3.53 | 0.33 | 0.00 | 0.14 | 0.05 | 0.38 | 36.69 | 11.31 | 200 | 1.15 | 1.131 | 36.31 | 98.96 |
| WEST BLOCKS | | MHSA3 | MHSA5 | 8 | 4 | | | 0.20 | 29.2 | 29.2 | 3.53 | 0.33 | 0.20 | 0.20 | 0.06 | 0.40 | 35.72 | 50.69 | 200 | 1.09 | 1.102 | 35.32 | 98.88 |
| WEST BLOCKS | | MHSA5 | MHSA4 | | | | | | | 58.4 | 3.53 | 0.67 | | 0.34 | 0.11 | 0.78 | 34.39 | 39.56 | 200 | 1.01 | 1.060 | 33.61 | 97.73 |
| Block 1/2 Total | | MHSA4 | EXSAN | | | | | | | 116.8 | 3.53 | 1.34 | | 0.67 | 0.22 | 1.56 | 41.20 | 10.00 | 200 | 1.45 | 1.271 | 39.64 | 96.22 |
| NORTH BLOCK | | MHSA11 | MHSA8 | 8 | 4 | | | 0.22 | 29.2 | 29.2 | 3.53 | 0.33 | 0.22 | 0.22 | 0.07 | 0.41 | 36.53 | 44.04 | 200 | 1.14 | 1.127 | 36.13 | 98.89 |
| NORTH BLOCK | | MHSA8 | MHSA7 | | | | | | 29.2 | 29.2 | 3.53 | 0.33 | 0.00 | 0.22 | 0.07 | 0.41 | 34.73 | 36.95 | 200 | 1.03 | 1.071 | 34.32 | 98.83 |
| | | MHSA7 | EXMH-S | 8 | 4 | | | 0.22 | 29.2 | 58.4 | 3.53 | 0.67 | 0.22 | 0.43 | 0.14 | 0.81 | 34.39 | 9.65 | 200 | 1.01 | 1.060 | 33.58 | 97.64 |
| *Ex Building (North) | | EXMH-S | EXMH-S | | | | 188 | 0.43 | 338.4 | 396.8 | 3.53 | 4.54 | 0.43 | 0.86 | 0.28 | 4.82 | 49.58 | 58.10 | 200 | 2.10 | 1.529 | 44.76 | 90.27 |
| | | EXMH-S | EXMH-S | | | | | | 0.0 | 396.8 | 3.53 | 4.54 | 0.00 | 0.86 | 0.28 | 4.82 | 50.75 | 11.80 | 200 | 2.20 | 1.565 | 45.93 | 90.49 |
| Design Parameters: | | | | Notes: | | | | | | | | Designed: | | | Revision | | | Date | | | | | |
| Residential | | | | 1. Mannings coefficient (n) = 0.013 | | | | | | | | MR | | | ISSUED FOR REVIEW | | | 2025.09.09 | | | | | |
| | | | | 2. Demand (per capita): 280 L/day | | | | | | | | | | | ISSUED FOR REVIEW | | | 2025.12.09 | | | | | |
| | | | | 3. Infiltration allowance: 0.33 L/s/Ha | | | | | | | | Checked: | | | | | | | | | | | |
| | | | | 4. Residential Peaking Factor: Harmon Formula = $1+(14/(4+P^{0.5}))^{0.8}$ where P = population in thousands | | | | | | | | JB | | | | | | | | | | | |
| 2BD 2.1 p/p/u 3BD 3.1 p/p/u APT 1.8 p/p/u Other 60 p/p/Ha | | | | INST 28,000 L/Ha/day COM 28,000 L/Ha/day IND 35,000 L/Ha/day | | | | | | | | Project No.: CCO-22-1241 | | | | | | Sheet No: 1 of 1 | | | | | |
| | | | | Peak Factor 1.5 1.5 MOE Chart | | | | | | | | | | | | | | | | | | | |

APPENDIX E
STORMWATER CALCULATION





CO-22-1241 - 2025 Othello - SWM Calculations

| Tc (min) | Intensity (mm/hr) | | | | C-Values | |
|----------|-------------------|--------|----------|------------------|------------|--------|
| | 2-Year | 5-Year | 100-Year | | Impervious | Gravel |
| 10 | 76.5 | 104.2 | 178.6 | PRE-DEVELOPMENT | 0.90 | 0.60 |
| 10 | 76.5 | 104.2 | 178.6 | POST-DEVELOPMENT | 0.20 | |

Pre-Development Runoff Coefficient

| Drainage Area | Impervious Area (m ²) | Gravel (m ²) | Pervious Area (m ²) | Average C (2-year) | Average C (5-year) | Average C (100-year) |
|---------------|-----------------------------------|--------------------------|---------------------------------|--------------------|--------------------|----------------------|
| A1 | 9,842 | 0 | 2,808 | 0.74 | 0.74 | 0.83 |
| A2 | 5,320 | 0 | 887 | 0.80 | 0.80 | 0.89 |
| A3 | 3,095 | 0 | 0 | 0.90 | 0.90 | 1.00 |
| A4 | 852 | 0 | 1,410 | 0.46 | 0.46 | 0.53 |

Pre-Development Runoff Calculations

| Drainage Area | Area (ha) | C | | | Tc (min) | Q (L/s) | | | |
|---------------|-----------|--------|--------|----------|----------|---------|--------|----------|--|
| | | 2-Year | 5-Year | 100-Year | | 2-Year | 5-Year | 100-Year | |
| A1 | 1.27 | 0.74 | 0.74 | 0.83 | 10 | 200.36 | 272.84 | 523.40 | Sewer to Pleasant Park Rd. |
| A2 | 0.62 | 0.80 | 0.80 | 0.89 | 10 | 105.62 | 143.83 | 275.09 | Sewer to Othello Ave. - Existing Conditions to be improved |
| A3 | 0.31 | 0.90 | 0.90 | 1.00 | 10 | 59.25 | 80.68 | 153.63 | Existing Buildings |
| A4 | 0.23 | 0.46 | 0.46 | 0.53 | 10 | 22.31 | 30.38 | 59.79 | Uncontrolled Runoff |
| Total | 2.42 | | | | | 387.55 | 527.73 | 798.49 | |

Post-Development Runoff Coefficient

| Drainage Area | Impervious Area (m ²) | Gravel (m ²) | Pervious Area (m ²) | Average C (2-year) | Average C (5-year) | Average C (100-year) |
|---------------|-----------------------------------|--------------------------|---------------------------------|--------------------|--------------------|----------------------|
| B1 | 3,369 | 0 | 1,341 | 0.70 | 0.70 | 0.79 |
| B2 | 5,450 | 0 | 1,469 | 0.75 | 0.75 | 0.84 |
| B3 | 4,781 | 0 | 1,219 | 0.76 | 0.76 | 0.85 |
| B4 | 3,095 | 0 | 0 | 0.90 | 0.90 | 1.00 |
| B5 | 1,502 | 0 | 1,988 | 0.50 | 0.50 | 0.57 |

Post-Development Runoff Calculations

| Drainage Area | Area (ha) | C | | | Tc (min) | Q (L/s) | | | |
|---------------|-----------|--------|--------|----------|----------|---------|--------|----------|--|
| | | 2-Year | 5-Year | 100-Year | | 2-Year | 5-Year | 100-Year | |
| B1 | 0.47 | 0.70 | 0.70 | 0.79 | 10 | 70.20 | 95.60 | 183.88 | Sewer to Pleasant Park Rd. |
| B2 | 0.69 | 0.75 | 0.75 | 0.84 | 10 | 110.59 | 150.59 | 288.76 | Sewer to Pleasant Park Rd. |
| B3 | 0.60 | 0.76 | 0.76 | 0.85 | 10 | 96.71 | 131.70 | 252.45 | Sewer to Othello Ave. - Existing Conditions to be improved |
| B4 | 0.31 | 0.90 | 0.90 | 1.00 | 10 | 59.25 | 80.68 | 153.63 | Existing Buildings |
| B5 | 0.35 | 0.50 | 0.50 | 0.57 | 10 | 37.21 | 50.67 | 99.23 | Uncontrolled Runoff |
| Total | 2.42 | | | | | 373.97 | 509.24 | 977.96 | |

Required Post-Development Flow

| Drainage Area | Q (L/s) | |
|---------------|---------|--|
| A1 | 200.36 | * Less than 2-year pre-development to Pleasant Park |
| A2 | 275.09 | * Drainage to Othello is to be improved by development - restriction devices to be added to improve drainage strategy per report |
| A3 | 153.63 | * Existing buildings to remain unchanged |
| A4 | 59.79 | * Difference in uncontrolled to be addressed by decreasing the total |
| Total | 688.88 | * Total in post-development to be less than this value |

Post-Development Restricted Runoff Calculations

| Drainage Area | Unrestricted Flow | | | Restricted Flow | | | Storage Required (m ³) | | | Storage Provided (m ³) | | |
|-----------------------|-------------------|--------|----------|-----------------|--------|----------|------------------------------------|--------|----------|------------------------------------|--------|----------|
| | 2-year | 5-year | 100-Year | 2-Year | 5-Year | 100-Year | 2-Year | 5-Year | 100-Year | 2-Year | 5-Year | 100-Year |
| B1 (B1a+B1b+B1c+B1d) | 70.20 | 95.60 | 183.88 | 10.00 | 10.10 | 33.40 | 23.21 | 40.9 | 111.2 | 24.8 | 42.8 | 111.7 |
| B2 (B2a+B2b) | 110.59 | 150.59 | 288.76 | 21.81 | 24.81 | 35.57 | 75.03 | 115.5 | 269.4 | 77.3 | 118.9 | 269.1 |
| Total (Pleasant Park) | 180.79 | 246.18 | 472.64 | 31.81 | 34.91 | 68.97 | 98.24 | 156.39 | 380.65 | 102.16 | 161.76 | 380.80 |
| B3 (B3a+B3b+B3c+B3d) | 96.71 | 131.70 | 252.45 | 70.30 | 83.03 | 127.16 | 21.58 | 35.0 | 92.8 | 22.69 | 35.8 | 99.9 |
| B4 | 59.25 | 80.68 | 153.63 | 59.25 | 80.68 | 153.63 | | | | | | |
| B5 | 37.21 | 50.67 | 99.23 | 37.21 | 50.67 | 99.23 | | | | | | |
| Total | 554.76 | 755.42 | 1450.60 | 230.37 | 284.21 | 448.99 | 218.06 | 347.81 | 854.12 | 227.01 | 359.29 | 861.52 |



Storage Requirements for Area B1a

2-Year Storm Event

| Tc (min) | I (mm/hr) | Runoff (L/s) B1a | Allowable Outflow (L/s) | Runoff to be Stored (L/s) | Storage Required (m³) |
|----------|-----------|------------------|-------------------------|---------------------------|-----------------------|
| 0 | 166.0 | 68.01 | 10.00 | 58.01 | 0.00 |
| 5 | 102.6 | 42.03 | 10.00 | 32.03 | 9.61 |
| 10 | 76.0 | 31.14 | 10.00 | 21.14 | 12.68 |
| 15 | 61.0 | 24.99 | 10.00 | 14.99 | 13.49 |
| 20 | 51.4 | 21.06 | 10.00 | 11.06 | 13.27 |

Maximum Storage Required 2-year = 13 m³

5-Year Storm Event

| Tc (min) | I (mm/hr) | Runoff (L/s) B1a | Allowable Outflow (L/s) | Runoff to be Stored (L/s) | Storage Required (m³) |
|----------|-----------|------------------|-------------------------|---------------------------|-----------------------|
| 0 | 230.5 | 94.43 | 10.10 | 84.33 | 0.00 |
| 10 | 104.2 | 42.69 | 10.10 | 32.59 | 19.55 |
| 20 | 70.3 | 28.80 | 10.10 | 18.70 | 22.44 |
| 30 | 53.9 | 22.08 | 10.10 | 11.98 | 21.57 |
| 40 | 44.2 | 18.11 | 10.10 | 8.01 | 19.22 |

Maximum Storage Required 5-year = 22 m³

100-Year Storm Event

| Tc (min) | I (mm/hr) | Runoff (L/s) B1a | Allowable Outflow (L/s) | Runoff to be Stored (L/s) | Storage Required (m³) |
|----------|-----------|------------------|-------------------------|---------------------------|-----------------------|
| 0 | 398.6 | 184.11 | 10.20 | 173.91 | 0.00 |
| 10 | 178.6 | 82.49 | 10.20 | 72.29 | 43.38 |
| 20 | 120.0 | 55.43 | 10.20 | 45.23 | 54.27 |
| 30 | 91.9 | 42.45 | 10.20 | 32.25 | 58.05 |
| 40 | 75.1 | 34.69 | 10.20 | 24.49 | 58.77 |
| 50 | 64.0 | 29.56 | 10.20 | 19.36 | 58.08 |
| 60 | 55.9 | 25.82 | 10.20 | 15.62 | 56.23 |
| 70 | 49.8 | 23.00 | 10.20 | 12.80 | 53.77 |
| 80 | 45.0 | 20.79 | 10.20 | 10.59 | 50.81 |
| 90 | 41.1 | 18.98 | 10.20 | 8.78 | 47.43 |

Maximum Storage Required 100-year = 59 m³

2-Year Storm Event Storage Summary

| Location | INV. (in) | INV. (out) | Area (m²) | Depth (m) | Head (m) | Volume (m³) |
|----------|-----------|------------|-----------|-----------|----------|-------------|
| CBMH4 | 75.50 | 73.39 | 223.2 | 0.18 | 2.32 | 14.5 |

Storage Available (m³) = 14.5
Storage Required (m³) = 13.5

5-Year Storm Event Storage Summary

| Location | T/G | INV. (out) | Area (m²) | Depth (m) | Head (m) | Volume (m³) |
|----------|-------|------------|-----------|-----------|----------|-------------|
| CBMH4 | 75.50 | 73.39 | 315.2 | 0.22 | 2.36 | 23.5 |

Storage Available (m³) = 23.5
Storage Required (m³) = 22.4

100-Year Storm Event Storage Summary

| Location | T/G | INV. (out) | Area (m²) | Depth (m) | Head (m) | Volume (m³) |
|----------|-------|------------|-----------|-----------|----------|-------------|
| CBMH4 | 75.50 | 73.39 | 561.3 | 0.30 | 2.44 | 58.9 |

Storage Available (m³) = 58.9
Storage Required (m³) = 58.8

* Available Storage calculated from AutoCAD

| Drainage Area | Area (ha) | C 2-Year | C 5-Year | C 100-Year | Tc (min) | Q (L/s) | |
|---------------|-----------|----------|----------|------------|----------|---------|-------|
| B1a | 0.23 | 0.65 | 0.65 | 0.73 | 10 | 31.35 | 82.47 |

| Drainage Area | Impervious Area (m²) | Gravel (m²) | Pervious Area (m²) | Average C (2-year) | Average C (5-year) | Average C (100-year) |
|---------------|----------------------|-------------|--------------------|--------------------|--------------------|----------------------|
| B1a | 1,455 | 0 | 821 | 0.65 | 0.65 | 0.73 |

| | |
|-----------------------------|-----------|
| For Orifice Flow, C= | 0.6 |
| For Weir Flow, C= | 3.33 |
| | Orifice 1 |
| Invert Elevation | 73.36 |
| Center of Crest Elevation | 73.39 |
| Orifice Width / Weir Length | 56.00 |
| Orifice Height | NA |
| Orifice Area (m²) | 0.002 |

ICD:
IPEX LMF 85

B1a

| Elevation (m) | Orifice 1 H (m) | Q (m³/s) | Total Q (L/s) |
|---------------|-----------------|----------|---------------|
| 73.39 | x | x | 0.0 |
| 75.49 | 2.13 | 0.010 | 9.5 |
| 75.50 | 2.14 | 0.010 | 9.6 |
| 75.51 | 2.15 | 0.010 | 9.6 |
| 75.52 | 2.16 | 0.010 | 9.6 |
| 75.53 | 2.17 | 0.010 | 9.6 |
| 75.54 | 2.18 | 0.010 | 9.7 |
| 75.55 | 2.19 | 0.010 | 9.7 |
| 75.56 | 2.20 | 0.010 | 9.7 |
| 75.57 | 2.21 | 0.010 | 9.7 |
| 75.58 | 2.22 | 0.010 | 9.7 |
| 75.59 | 2.23 | 0.010 | 9.8 |
| 75.60 | 2.24 | 0.010 | 9.8 |
| 75.61 | 2.25 | 0.010 | 9.8 |
| 75.62 | 2.26 | 0.010 | 9.8 |
| 75.63 | 2.27 | 0.010 | 9.9 |
| 75.64 | 2.28 | 0.010 | 9.9 |
| 75.65 | 2.29 | 0.010 | 9.9 |
| 75.66 | 2.30 | 0.010 | 9.9 |
| 75.67 | 2.31 | 0.010 | 9.9 |
| 75.68 | 2.32 | 0.010 | 10.0 |
| 75.69 | 2.33 | 0.010 | 10.0 |
| 75.70 | 2.34 | 0.010 | 10.0 |
| 75.71 | 2.35 | 0.010 | 10.0 |
| 75.72 | 2.36 | 0.010 | 10.1 |
| 75.73 | 2.37 | 0.010 | 10.1 |
| 75.74 | 2.38 | 0.010 | 10.1 |
| 75.75 | 2.39 | 0.010 | 10.1 |
| 75.76 | 2.40 | 0.010 | 10.1 |
| 75.77 | 2.41 | 0.010 | 10.2 |
| 75.78 | 2.42 | 0.010 | 10.2 |
| 75.79 | 2.43 | 0.010 | 10.2 |
| 75.80 | 2.44 | 0.010 | 10.2 |
| 75.81 | 2.45 | 0.010 | 10.2 |

2-year

5-year

100-year



Storage Requirements for Area B1b

2-Year Storm Event

| Tc (min) | I (mm/hr) | Runoff (L/s) B1b | Allowable Outflow (L/s) | Runoff to be Stored (L/s) | Storage Required (m ³) |
|----------|-----------|------------------|-------------------------|---------------------------|------------------------------------|
| 0 | 166.0 | 41.17 | 12.50 | 28.67 | 0.00 |
| 5 | 102.6 | 25.45 | 12.50 | 12.95 | 3.88 |
| 10 | 76.0 | 18.85 | 12.50 | 6.35 | 3.81 |
| 15 | 61.0 | 15.13 | 12.50 | 2.63 | 2.37 |
| 20 | 51.4 | 12.75 | 12.50 | 0.25 | 0.30 |

Maximum Storage Required 2-year = 4 m³

5-Year Storm Event

| Tc (min) | I (mm/hr) | Runoff (L/s) B1b | Allowable Outflow (L/s) | Runoff to be Stored (L/s) | Storage Required (m ³) |
|----------|-----------|------------------|-------------------------|---------------------------|------------------------------------|
| 0 | 230.5 | 57.17 | 12.60 | 44.57 | 0.00 |
| 5 | 141.2 | 35.02 | 12.60 | 22.42 | 6.73 |
| 10 | 104.2 | 25.84 | 12.60 | 13.24 | 7.95 |
| 15 | 83.6 | 20.74 | 12.60 | 8.14 | 7.32 |
| 20 | 70.3 | 17.44 | 12.60 | 4.84 | 5.80 |

Maximum Storage Required 5-year = 8 m³

100-Year Storm Event

| Tc (min) | I (mm/hr) | Runoff (L/s) B1b | Allowable Outflow (L/s) | Runoff to be Stored (L/s) | Storage Required (m ³) |
|----------|-----------|------------------|-------------------------|---------------------------|------------------------------------|
| 0 | 398.6 | 110.37 | 13.30 | 97.07 | 0.00 |
| 5 | 242.7 | 67.20 | 13.30 | 53.90 | 16.17 |
| 10 | 178.6 | 49.45 | 13.30 | 36.15 | 21.69 |
| 15 | 142.9 | 39.57 | 13.30 | 26.27 | 23.64 |
| 20 | 120.0 | 33.23 | 13.30 | 19.93 | 23.91 |
| 25 | 103.8 | 28.74 | 13.30 | 15.44 | 23.16 |
| 30 | 91.9 | 25.45 | 13.30 | 12.15 | 21.86 |
| 35 | 82.6 | 22.87 | 13.30 | 9.57 | 20.10 |
| 40 | 75.1 | 20.79 | 13.30 | 7.49 | 17.99 |
| 45 | 69.1 | 19.13 | 13.30 | 5.83 | 15.75 |

Maximum Storage Required 100-year = 24 m³

2-Year Storm Event Storage Summary

| Location | INV. (in) | INV. (out) | Area (m ²) | Depth (m) | Head (m) | Volume (m ³) |
|----------|-----------|------------|------------------------|-----------|----------|--------------------------|
| EX CB3 | 75.20 | 73.49 | 90.7 | 0.14 | 1.88 | 4.5 |

Storage Available (m³) = 4.5
Storage Required (m³) = 3.9

5-Year Storm Event Storage Summary

| Location | T/G | INV. (out) | Area (m ²) | Depth (m) | Head (m) | Volume (m ³) |
|----------|-------|------------|------------------------|-----------|----------|--------------------------|
| EX CB3 | 75.20 | 73.49 | 149.2 | 0.18 | 1.92 | 9.3 |

Storage Available (m³) = 9.3
Storage Required (m³) = 7.9

100-Year Storm Event Storage Summary

| Location | T/G | INV. (out) | Area (m ²) | Depth (m) | Head (m) | Volume (m ³) |
|----------|-------|------------|------------------------|-----------|----------|--------------------------|
| EX CB3 | 75.20 | 73.49 | 284.4 | 0.25 | 2.14 | 24.2 |

Storage Available (m³) = 24.2
Storage Required (m³) = 23.9

* Available Storage calculated from AutoCAD

| Drainage Area | Area (ha) | C 2-Year | C 5-Year | C 100-Year | Tc (min) | Q (L/s) | | |
|---------------|-----------|----------|----------|------------|----------|---------|-------|-------|
| B1b | 0.11 | 0.80 | 0.80 | 0.89 | 10 | 18.98 | 25.84 | 49.44 |

| Drainage Area | Impervious Area (m ²) | Gravel (m ²) | Pervious Area (m ²) | Average C (2-year) | Average C (5-year) | Average C (100-year) |
|---------------|-----------------------------------|--------------------------|---------------------------------|--------------------|--------------------|----------------------|
| B1b | 954 | 0 | 168 | 0.80 | 0.80 | 0.89 |

| | |
|--------------------------------|-----------|
| For Orifice Flow, C= | 0.6 |
| For Weir Flow, C= | 3.33 |
| | Orifice 1 |
| Invert Elevation | 73.46 |
| Center of Crest Elevation | 73.49 |
| Orifice Width / Weir Length | 66.00 |
| Orifice Height | NA |
| Orifice Area (m ²) | 0.003 |

ICD:
IPEXLMF100

B1b

| Elevation (m) | Orifice 1 (m) | H | Q (m ³ /s) | Total Q (L/s) |
|---------------|---------------|---|-----------------------|---------------|
| 73.49 | x | | x | 0.0 |
| 75.29 | 1.83 | | 0.012 | 12.3 |
| 75.30 | 1.84 | | 0.012 | 12.3 |
| 75.31 | 1.85 | | 0.012 | 12.4 |
| 75.32 | 1.86 | | 0.012 | 12.4 |
| 75.33 | 1.87 | | 0.012 | 12.4 |
| 75.34 | 1.88 | | 0.012 | 12.5 |
| 75.35 | 1.89 | | 0.013 | 12.5 |
| 75.36 | 1.90 | | 0.013 | 12.5 |
| 75.37 | 1.91 | | 0.013 | 12.6 |
| 75.38 | 1.92 | | 0.013 | 12.6 |
| 75.39 | 1.93 | | 0.013 | 12.6 |
| 75.40 | 1.94 | | 0.013 | 12.7 |
| 75.41 | 1.95 | | 0.013 | 12.7 |
| 75.42 | 1.96 | | 0.013 | 12.7 |
| 75.43 | 1.97 | | 0.013 | 12.8 |
| 75.44 | 1.98 | | 0.013 | 12.8 |
| 75.45 | 1.99 | | 0.013 | 12.8 |
| 75.46 | 2.00 | | 0.013 | 12.9 |
| 75.47 | 2.01 | | 0.013 | 12.9 |
| 75.48 | 2.02 | | 0.013 | 12.9 |
| 75.49 | 2.03 | | 0.013 | 13.0 |
| 75.50 | 2.04 | | 0.013 | 13.0 |
| 75.51 | 2.05 | | 0.013 | 13.0 |
| 75.52 | 2.06 | | 0.013 | 13.1 |
| 75.53 | 2.07 | | 0.013 | 13.1 |
| 75.54 | 2.08 | | 0.013 | 13.1 |
| 75.55 | 2.09 | | 0.013 | 13.2 |
| 75.56 | 2.10 | | 0.013 | 13.2 |
| 75.57 | 2.11 | | 0.013 | 13.2 |
| 75.58 | 2.12 | | 0.013 | 13.2 |
| 75.59 | 2.13 | | 0.013 | 13.3 |
| 75.60 | 2.14 | | 0.013 | 13.3 |
| 75.61 | 2.15 | | 0.013 | 13.3 |

2-year

5-year

100-year



Storage Requirements for Area B1c

2-Year Storm Event

| Tc (min) | I (mm/hr) | Runoff (L/s) B1c | Allowable Outflow (L/s) | Runoff to be Stored (L/s) | Storage Required (m ³) |
|----------|-----------|------------------|-------------------------|---------------------------|------------------------------------|
| 0 | 166.0 | 18.82 | 4.80 | 14.02 | 0.00 |
| 5 | 102.6 | 11.63 | 4.80 | 6.83 | 2.05 |
| 10 | 76.0 | 8.62 | 4.80 | 3.82 | 2.29 |
| 15 | 61.0 | 6.92 | 4.80 | 2.12 | 1.90 |
| 20 | 51.4 | 5.83 | 4.80 | 1.03 | 1.23 |

Maximum Storage Required 2-year = 2 m³

5-Year Storm Event

| Tc (min) | I (mm/hr) | Runoff (L/s) B1c | Allowable Outflow (L/s) | Runoff to be Stored (L/s) | Storage Required (m ³) |
|----------|-----------|------------------|-------------------------|---------------------------|------------------------------------|
| 0 | 230.5 | 26.13 | 4.80 | 21.33 | 0.00 |
| 5 | 141.2 | 16.01 | 4.80 | 11.21 | 3.36 |
| 10 | 104.2 | 11.81 | 4.80 | 7.01 | 4.21 |
| 15 | 83.6 | 9.48 | 4.80 | 4.68 | 4.21 |
| 20 | 70.3 | 7.97 | 4.80 | 3.17 | 3.80 |

Maximum Storage Required 5-year = 4 m³

100-Year Storm Event

| Tc (min) | I (mm/hr) | Runoff (L/s) B1c | Allowable Outflow (L/s) | Runoff to be Stored (L/s) | Storage Required (m ³) |
|----------|-----------|------------------|-------------------------|---------------------------|------------------------------------|
| 0 | 398.6 | 47.08 | 4.90 | 42.18 | 0.00 |
| 5 | 242.7 | 28.67 | 4.90 | 23.77 | 7.13 |
| 10 | 178.6 | 21.09 | 4.90 | 16.19 | 9.72 |
| 15 | 142.9 | 16.88 | 4.90 | 11.98 | 10.78 |
| 20 | 120.0 | 14.17 | 4.90 | 9.27 | 11.13 |
| 25 | 103.8 | 12.26 | 4.90 | 7.36 | 11.04 |
| 30 | 91.9 | 10.85 | 4.90 | 5.95 | 10.72 |
| 35 | 82.6 | 9.76 | 4.90 | 4.86 | 10.20 |
| 40 | 75.1 | 8.87 | 4.90 | 3.97 | 9.53 |
| 45 | 69.1 | 8.16 | 4.90 | 3.26 | 8.81 |

Maximum Storage Required 100-year = 11 m³

2-Year Storm Event Storage Summary

| Water Elev. (m) = 75.5 | | | | | | |
|------------------------|-----------|------------|------------------------|-----------|----------|--------------------------|
| Location | INV. (in) | INV. (out) | Area (m ²) | Depth (m) | Head (m) | Volume (m ³) |
| EX CB1 | 75.45 | 73.48 | 45.6 | 0.05 | 2.03 | 2.7 |

Storage Available (m³) = 2.7
Storage Required (m³) = 2.3

5-Year Storm Event Storage Summary

| Water Elev. (m) = 75.53 | | | | | | |
|-------------------------|-------|------------|------------------------|-----------|----------|--------------------------|
| Location | T/G | INV. (out) | Area (m ²) | Depth (m) | Head (m) | Volume (m ³) |
| EX CB1 | 75.45 | 73.48 | 66.0 | 0.08 | 2.06 | 4.6 |

Storage Available (m³) = 4.6
Storage Required (m³) = 4.2

100-Year Storm Event Storage Summary

| Water Elev. (m) = 75.64 | | | | | | |
|-------------------------|-------|------------|------------------------|-----------|----------|--------------------------|
| Location | T/G | INV. (out) | Area (m ²) | Depth (m) | Head (m) | Volume (m ³) |
| EX CB1 | 75.45 | 73.48 | 91.6 | 0.19 | 2.16 | 12.6 |

Storage Available (m³) = 12.6
Storage Required (m³) = 11.1

* Available Storage calculated from AutoCAD

| Drainage Area | Area (ha) | C 2-Year | C 5-Year | C 100-Year | Tc (min) | Q (L/s) | | |
|---------------|-----------|----------|----------|------------|----------|---------|-------|-------|
| B1c | 0.06 | 0.70 | 0.70 | 0.73 | 10 | 8.67 | 11.81 | 21.09 |

| Drainage Area | Impervious Area (m ²) | Gravel (m ²) | Pervious Area (m ²) | Average C (2-year) | Average C (5-year) | Average C (100-year) |
|---------------|-----------------------------------|--------------------------|---------------------------------|--------------------|--------------------|----------------------|
| B1c | 375 | 0 | 207 | 0.70 | 0.70 | 0.73 |

| | |
|--------------------------------|-----------|
| For Orifice Flow, C= | 0.6 |
| For Weir Flow, C= | 3.33 |
| | Orifice 1 |
| Invert Elevation | 73.46 |
| Center of Crest Elevation | 73.48 |
| Orifice Width / Weir Length | 40.00 |
| Orifice Height | NA |
| Orifice Area (m ²) | 0.001 |

ICD:
IPEX LMF 65

B1c

| Elevation (m) | Orifice 1 (m) | H | Q (m ³ /s) | Total Q (L/s) |
|---------------|---------------|-------|-----------------------|---------------|
| 73.48 | x | x | x | 0.0 |
| 75.38 | 1.92 | 0.005 | 4.6 | |
| 75.39 | 1.93 | 0.005 | 4.6 | |
| 75.40 | 1.94 | 0.005 | 4.7 | |
| 75.41 | 1.95 | 0.005 | 4.7 | |
| 75.42 | 1.96 | 0.005 | 4.7 | |
| 75.43 | 1.97 | 0.005 | 4.7 | |
| 75.44 | 1.98 | 0.005 | 4.7 | |
| 75.45 | 1.99 | 0.005 | 4.7 | |
| 75.46 | 2.00 | 0.005 | 4.7 | |
| 75.47 | 2.01 | 0.005 | 4.7 | |
| 75.48 | 2.02 | 0.005 | 4.7 | |
| 75.49 | 2.03 | 0.005 | 4.8 | |
| 75.50 | 2.04 | 0.005 | 4.8 | 2-year |
| 75.51 | 2.05 | 0.005 | 4.8 | |
| 75.52 | 2.06 | 0.005 | 4.8 | |
| 75.53 | 2.07 | 0.005 | 4.8 | 5-year |
| 75.54 | 2.08 | 0.005 | 4.8 | |
| 75.55 | 2.09 | 0.005 | 4.8 | |
| 75.56 | 2.10 | 0.005 | 4.8 | |
| 75.57 | 2.11 | 0.005 | 4.9 | |
| 75.58 | 2.12 | 0.005 | 4.9 | |
| 75.59 | 2.13 | 0.005 | 4.9 | |
| 75.60 | 2.14 | 0.005 | 4.9 | |
| 75.61 | 2.15 | 0.005 | 4.9 | |
| 75.62 | 2.16 | 0.005 | 4.9 | |
| 75.63 | 2.17 | 0.005 | 4.9 | |
| 75.64 | 2.18 | 0.005 | 4.9 | 100-year |
| 75.65 | 2.19 | 0.005 | 4.9 | |
| 75.66 | 2.20 | 0.005 | 5.0 | |
| 75.67 | 2.21 | 0.005 | 5.0 | |
| 75.68 | 2.22 | 0.005 | 5.0 | |
| 75.69 | 2.23 | 0.005 | 5.0 | |
| 75.70 | 2.24 | 0.005 | 5.0 | |



Storage Requirements for Area B1d

2-Year Storm Event

| Tc (min) | I (mm/hr) | Runoff (L/s) B1d | Allowable Outflow (L/s) | Runoff to be Stored (L/s) | Storage Required (m³) |
|----------|-----------|------------------|-------------------------|---------------------------|-----------------------|
| 0 | 166.0 | 23.61 | 4.90 | 18.71 | 0.00 |
| 5 | 102.6 | 14.59 | 4.90 | 9.69 | 2.91 |
| 10 | 76.0 | 10.81 | 4.90 | 5.91 | 3.54 |
| 15 | 61.0 | 8.67 | 4.90 | 3.77 | 3.40 |
| 20 | 51.4 | 7.31 | 4.90 | 2.41 | 2.89 |

Maximum Storage Required 2-year = 4 m³

5-Year Storm Event

| Tc (min) | I (mm/hr) | Runoff (L/s) B1d | Allowable Outflow (L/s) | Runoff to be Stored (L/s) | Storage Required (m³) |
|----------|-----------|------------------|-------------------------|---------------------------|-----------------------|
| 0 | 230.5 | 32.78 | 4.90 | 27.88 | 0.00 |
| 5 | 141.2 | 20.08 | 4.90 | 15.18 | 4.55 |
| 10 | 104.2 | 14.82 | 4.90 | 9.92 | 5.95 |
| 15 | 83.6 | 11.89 | 4.90 | 6.99 | 6.29 |
| 20 | 70.3 | 10.00 | 4.90 | 5.10 | 6.12 |

Maximum Storage Required 5-year = 6 m³

100-Year Storm Event

| Tc (min) | I (mm/hr) | Runoff (L/s) B1d | Allowable Outflow (L/s) | Runoff to be Stored (L/s) | Storage Required (m³) |
|----------|-----------|------------------|-------------------------|---------------------------|-----------------------|
| 0 | 398.6 | 63.62 | 5.00 | 58.62 | 0.00 |
| 5 | 242.7 | 38.74 | 5.00 | 33.74 | 10.12 |
| 10 | 178.6 | 28.51 | 5.00 | 23.51 | 14.10 |
| 15 | 142.9 | 22.81 | 5.00 | 17.81 | 16.03 |
| 20 | 120.0 | 19.15 | 5.00 | 14.15 | 16.98 |
| 25 | 103.8 | 16.57 | 5.00 | 11.57 | 17.35 |
| 30 | 91.9 | 14.67 | 5.00 | 9.67 | 17.40 |
| 35 | 82.6 | 13.18 | 5.00 | 8.18 | 17.19 |
| 40 | 75.1 | 11.99 | 5.00 | 6.99 | 16.77 |
| 45 | 69.1 | 11.03 | 5.00 | 6.03 | 16.28 |

Maximum Storage Required 100-year = 17 m³

2-Year Storm Event Storage Summary

| Location | INV. (in) | INV. (out) | Area (m²) | Depth (m) | Head (m) | Volume (m³) |
|----------|-----------|------------|-----------|-----------|----------|-------------|
| EX CB2 | 75.45 | 73.48 | 64.0 | 0.14 | 2.13 | 3.2 |

Storage Available (m³) = 3.2
Storage Required (m³) = 3.5

5-Year Storm Event Storage Summary

| Location | T/G | INV. (out) | Area (m²) | Depth (m) | Head (m) | Volume (m³) |
|----------|-------|------------|-----------|-----------|----------|-------------|
| EX CB2 | 75.45 | 73.48 | 92.6 | 0.17 | 2.16 | 5.5 |

Storage Available (m³) = 5.5
Storage Required (m³) = 6.3

100-Year Storm Event Storage Summary

| Location | T/G | INV. (out) | Area (m²) | Depth (m) | Head (m) | Volume (m³) |
|----------|-------|------------|-----------|-----------|----------|-------------|
| EX CB2 | 75.45 | 73.48 | 154.6 | 0.27 | 2.33 | 16.1 |

Storage Available (m³) = 16.1
Storage Required (m³) = 17.4

* Available Storage calculated from AutoCAD

| Drainage Area | Area (ha) | C 2-Year | C 5-Year | C 100-Year | Tc (min) | Q (L/s) | | |
|---------------|-----------|----------|----------|------------|----------|---------|-------|-------|
| B1d | 0.07 | 0.70 | 0.70 | 0.79 | 10 | 10.88 | 14.82 | 28.50 |

| Drainage Area | Impervious Area (m²) | Gravel (m²) | Pervious Area (m²) | Average C (2-year) | Average C (5-year) | Average C (100-year) |
|---------------|----------------------|-------------|--------------------|--------------------|--------------------|----------------------|
| B1d | 585 | 0 | 145 | 0.70 | 0.70 | 0.79 |

| | |
|-----------------------------|-----------|
| For Orifice Flow, C= | 0.6 |
| For Weir Flow, C= | 3.33 |
| | Orifice 1 |
| Invert Elevation | 73.46 |
| Center of Crest Elevation | 73.48 |
| Orifice Width / Weir Length | 40.00 |
| Orifice Height | NA |
| Orifice Area (m²) | 0.001 |

ICD:
IPEX LMF 60

B1d

| Elevation (m) | Orifice 1 (m) | H | Q (m³/s) | Total Q (L/s) |
|---------------|---------------|-------|----------|---------------|
| 73.48 | x | x | 0.0 | |
| 75.48 | 2.02 | 0.005 | 4.7 | |
| 75.49 | 2.03 | 0.005 | 4.8 | |
| 75.50 | 2.04 | 0.005 | 4.8 | |
| 75.51 | 2.05 | 0.005 | 4.8 | |
| 75.52 | 2.06 | 0.005 | 4.8 | |
| 75.53 | 2.07 | 0.005 | 4.8 | |
| 75.54 | 2.08 | 0.005 | 4.8 | |
| 75.55 | 2.09 | 0.005 | 4.8 | |
| 75.56 | 2.10 | 0.005 | 4.8 | |
| 75.57 | 2.11 | 0.005 | 4.9 | |
| 75.58 | 2.12 | 0.005 | 4.9 | |
| 75.59 | 2.13 | 0.005 | 4.9 | 2-year |
| 75.60 | 2.14 | 0.005 | 4.9 | |
| 75.61 | 2.15 | 0.005 | 4.9 | |
| 75.62 | 2.16 | 0.005 | 4.9 | 5-year |
| 75.63 | 2.17 | 0.005 | 4.9 | |
| 75.64 | 2.18 | 0.005 | 4.9 | |
| 75.65 | 2.19 | 0.005 | 4.9 | |
| 75.66 | 2.20 | 0.005 | 5.0 | |
| 75.67 | 2.21 | 0.005 | 5.0 | |
| 75.68 | 2.22 | 0.005 | 5.0 | |
| 75.69 | 2.23 | 0.005 | 5.0 | |
| 75.70 | 2.24 | 0.005 | 5.0 | |
| 75.71 | 2.25 | 0.005 | 5.0 | |
| 75.72 | 2.26 | 0.005 | 5.0 | 100-year |
| 75.73 | 2.27 | 0.005 | 5.0 | |
| 75.74 | 2.28 | 0.005 | 5.0 | |
| 75.75 | 2.29 | 0.005 | 5.1 | |
| 75.76 | 2.30 | 0.005 | 5.1 | |
| 75.77 | 2.31 | 0.005 | 5.1 | |
| 75.78 | 2.32 | 0.005 | 5.1 | |
| 75.79 | 2.33 | 0.005 | 5.1 | |
| 75.80 | 2.34 | 0.005 | 5.1 | |



Storage Requirements for Area B2a

2-Year Storm Event

| Tc (min) | I (mm/hr) | Runoff (L/s) B2a | Allowable Outflow (L/s) | Runoff to be Stored (L/s) | Storage Required (m ³) |
|----------|-----------|------------------|-------------------------|---------------------------|------------------------------------|
| 0 | 166.0 | 230.00 | 13.50 | 216.50 | 0.00 |
| 15 | 61.0 | 84.52 | 13.50 | 71.02 | 63.92 |
| 30 | 39.5 | 54.73 | 13.50 | 41.23 | 74.21 |
| 45 | 29.8 | 41.29 | 13.50 | 27.79 | 75.03 |
| 60 | 24.1 | 33.39 | 13.50 | 19.89 | 71.61 |

Maximum Storage Required 2-year = 75 m³

5-Year Storm Event

| Tc (min) | I (mm/hr) | Runoff (L/s) B2a | Allowable Outflow (L/s) | Runoff to be Stored (L/s) | Storage Required (m ³) |
|----------|-----------|------------------|-------------------------|---------------------------|------------------------------------|
| 0 | 230.5 | 319.37 | 13.50 | 305.87 | 0.00 |
| 20 | 70.3 | 97.40 | 13.50 | 83.90 | 100.69 |
| 40 | 44.2 | 61.24 | 13.50 | 47.74 | 114.58 |
| 60 | 32.9 | 45.58 | 13.50 | 32.08 | 115.50 |
| 80 | 26.6 | 36.86 | 13.50 | 23.36 | 112.11 |

Maximum Storage Required 5-year = 116 m³

100-Year Storm Event

| Tc (min) | I (mm/hr) | Runoff (L/s) B2a | Allowable Outflow (L/s) | Runoff to be Stored (L/s) | Storage Required (m ³) |
|----------|-----------|------------------|-------------------------|---------------------------|------------------------------------|
| 0 | 398.6 | 616.66 | 13.70 | 602.96 | 0.00 |
| 15 | 142.9 | 221.08 | 13.70 | 207.38 | 186.64 |
| 30 | 91.9 | 142.18 | 13.70 | 128.48 | 231.26 |
| 45 | 69.1 | 106.90 | 13.70 | 93.20 | 251.65 |
| 60 | 55.9 | 86.48 | 13.70 | 72.78 | 262.01 |
| 75 | 47.3 | 73.18 | 13.70 | 59.48 | 267.64 |
| 90 | 41.1 | 63.58 | 13.70 | 49.88 | 269.38 |
| 105 | 36.5 | 56.47 | 13.70 | 42.77 | 269.44 |
| 120 | 32.9 | 50.90 | 13.70 | 37.20 | 267.83 |
| 135 | 30.0 | 46.41 | 13.70 | 32.71 | 264.97 |

Maximum Storage Required 100-year = 269 m³

2-Year Storm Event Storage Summary

| Water Elev. (m) = 76.21 | | | | | | |
|-------------------------|-----------|------------|------------------------|-----------|----------|--------------------------|
| Location | INV. (in) | INV. (out) | Area (m ²) | Depth (m) | Head (m) | Volume (m ³) |
| EX CB7 | 76.05 | 72.80 | 1462.7 | 0.16 | 3.44 | 77.3 |

Storage Available (m³) = 77.3
Storage Required (m³) = 75.0

5-Year Storm Event Storage Summary

| Water Elev. (m) = 76.24 | | | | | | |
|-------------------------|-------|------------|------------------------|-----------|----------|--------------------------|
| Location | T/G | INV. (out) | Area (m ²) | Depth (m) | Head (m) | Volume (m ³) |
| EX CB7 | 76.05 | 72.80 | 1910.8 | 0.19 | 3.47 | 118.9 |

Storage Available (m³) = 118.9
Storage Required (m³) = 115.5

100-Year Storm Event Storage Summary

| Water Elev. (m) = 76.35 | | | | | | |
|-------------------------|-------|------------|------------------------|-----------|----------|--------------------------|
| Location | T/G | INV. (out) | Area (m ²) | Depth (m) | Head (m) | Volume (m ³) |
| EX CB7 | 76.05 | 72.80 | 2725.5 | 0.30 | 3.55 | 269.1 |

Storage Available (m³) = 269.1
Storage Required (m³) = 269.4

* Available Storage calculated from AutoCAD

| Drainage Area | Area (ha) | C 2-Year | C 5-Year | C 100-Year | Tc (min) | Q (L/s) | | |
|---------------|-----------|----------|----------|------------|----------|---------|--------|--------|
| B2a | 0.63 | 0.79 | 0.79 | 0.88 | 10 | 106.02 | 144.36 | 276.24 |

| Drainage Area | Impervious Area (m ²) | Gravel (m ²) | Pervious Area (m ²) | Average C (2-year) | Average C (5-year) | Average C (100-year) |
|---------------|-----------------------------------|--------------------------|---------------------------------|--------------------|--------------------|----------------------|
| B2a | 5,320 | 0 | 980 | 0.79 | 0.79 | 0.88 |

| | |
|--------------------------------|-----------|
| For Orifice Flow, C= | 0.6 |
| For Weir Flow, C= | 3.33 |
| | Orifice 1 |
| Invert Elevation | 72.77 |
| Center of Crest Elevation | 72.80 |
| Orifice Width / Weir Length | 59.00 |
| Orifice Height | NA |
| Orifice Area (m ²) | 0.003 |

IOD: IPEX LMF90

B2a

| Elevation (m) | Orifice 1 (m) | H | Q (m ³ /s) | Total Q (L/s) |
|---------------|---------------|-------|-----------------------|---------------|
| 72.80 | x | x | x | 0.0 |
| 76.00 | 3.23 | 0.013 | 0.013 | 13.1 |
| 76.01 | 3.24 | 0.013 | 0.013 | 13.1 |
| 76.02 | 3.25 | 0.013 | 0.013 | 13.1 |
| 76.03 | 3.26 | 0.013 | 0.013 | 13.1 |
| 76.04 | 3.27 | 0.013 | 0.013 | 13.1 |
| 76.05 | 3.28 | 0.013 | 0.013 | 13.2 |
| 76.06 | 3.29 | 0.013 | 0.013 | 13.2 |
| 76.07 | 3.30 | 0.013 | 0.013 | 13.2 |
| 76.08 | 3.31 | 0.013 | 0.013 | 13.2 |
| 76.09 | 3.32 | 0.013 | 0.013 | 13.2 |
| 76.10 | 3.33 | 0.013 | 0.013 | 13.3 |
| 76.11 | 3.34 | 0.013 | 0.013 | 13.3 |
| 76.12 | 3.35 | 0.013 | 0.013 | 13.3 |
| 76.13 | 3.36 | 0.013 | 0.013 | 13.3 |
| 76.14 | 3.37 | 0.013 | 0.013 | 13.3 |
| 76.15 | 3.38 | 0.013 | 0.013 | 13.4 |
| 76.16 | 3.39 | 0.013 | 0.013 | 13.4 |
| 76.17 | 3.40 | 0.013 | 0.013 | 13.4 |
| 76.18 | 3.41 | 0.013 | 0.013 | 13.4 |
| 76.19 | 3.42 | 0.013 | 0.013 | 13.4 |
| 76.20 | 3.43 | 0.013 | 0.013 | 13.5 |
| 76.21 | 3.44 | 0.013 | 0.013 | 13.5 |
| 76.22 | 3.45 | 0.013 | 0.013 | 13.5 |
| 76.23 | 3.46 | 0.014 | 0.014 | 13.5 |
| 76.24 | 3.47 | 0.014 | 0.014 | 13.5 |
| 76.25 | 3.48 | 0.014 | 0.014 | 13.6 |
| 76.26 | 3.49 | 0.014 | 0.014 | 13.6 |
| 76.27 | 3.50 | 0.014 | 0.014 | 13.6 |
| 76.28 | 3.51 | 0.014 | 0.014 | 13.6 |
| 76.29 | 3.52 | 0.014 | 0.014 | 13.6 |
| 76.30 | 3.53 | 0.014 | 0.014 | 13.7 |
| 76.31 | 3.54 | 0.014 | 0.014 | 13.7 |
| 76.32 | 3.55 | 0.014 | 0.014 | 13.7 |

2-year

5-year

100-year

| Drainage Area | Area (ha) | C 2-Year | C 5-Year | C 100-Year | Tc (min) | Q (L/s) | | |
|---------------|-----------|----------|----------|------------|----------|---------|--------|----------|
| | | | | | | 2-Year | 5-Year | 100-Year |
| B2b | 0.06 | 0.63 | 0.63 | 0.71 | 10 | 8.31 | 11.31 | 21.87 |

| Drainage Area | Impervious Area (m ²) | Gravel (m ²) | Pervious Area (m ²) | Average C (2-year) | Average C (5-year) | Average C (100-year) |
|---------------|-----------------------------------|--------------------------|---------------------------------|--------------------|--------------------|----------------------|
| B2b | 381 | 0 | 238 | 0.63 | 0.63 | 0.71 |

* No Proposed Storage



Storage Requirements for Area B3a

2-Year Storm Event

| Tc (min) | I (mm/hr) | Runoff (L/s) B3a | Allowable Outflow (L/s) | Runoff to be Stored (L/s) | Storage Required (m ³) |
|----------|-----------|------------------|-------------------------|---------------------------|------------------------------------|
| 0 | 166.0 | 59.74 | 3.50 | 56.24 | 0.00 |
| 15 | 61.0 | 21.95 | 3.50 | 18.45 | 16.61 |
| 30 | 39.5 | 14.21 | 3.50 | 10.71 | 19.29 |
| 45 | 29.8 | 10.72 | 3.50 | 7.22 | 19.51 |
| 60 | 24.1 | 8.67 | 3.50 | 5.17 | 18.62 |

Maximum Storage Required 2-year = 20 m³

5-Year Storm Event

| Tc (min) | I (mm/hr) | Runoff (L/s) B3a | Allowable Outflow (L/s) | Runoff to be Stored (L/s) | Storage Required (m ³) |
|----------|-----------|------------------|-------------------------|---------------------------|------------------------------------|
| 0 | 230.5 | 82.95 | 3.60 | 79.35 | 0.00 |
| 20 | 70.3 | 25.30 | 3.60 | 21.70 | 26.04 |
| 40 | 44.2 | 15.91 | 3.60 | 12.31 | 29.54 |
| 60 | 32.9 | 11.84 | 3.60 | 8.24 | 29.66 |
| 80 | 26.6 | 9.57 | 3.60 | 5.97 | 28.67 |

Maximum Storage Required 5-year = 30 m³

100-Year Storm Event

| Tc (min) | I (mm/hr) | Runoff (L/s) B3a | Allowable Outflow (L/s) | Runoff to be Stored (L/s) | Storage Required (m ³) |
|----------|-----------|------------------|-------------------------|---------------------------|------------------------------------|
| 0 | 398.6 | 160.37 | 3.60 | 156.77 | 0.00 |
| 20 | 120.0 | 48.28 | 3.60 | 44.68 | 53.62 |
| 40 | 75.1 | 30.22 | 3.60 | 26.62 | 63.88 |
| 60 | 55.9 | 22.49 | 3.60 | 18.89 | 68.01 |
| 80 | 45.0 | 18.11 | 3.60 | 14.51 | 69.62 |
| 100 | 37.9 | 15.25 | 3.60 | 11.65 | 69.89 |
| 120 | 32.9 | 13.24 | 3.60 | 9.64 | 69.39 |
| 140 | 29.2 | 11.75 | 3.60 | 8.15 | 68.44 |
| 160 | 26.2 | 10.54 | 3.60 | 6.94 | 66.64 |
| 180 | 23.9 | 9.62 | 3.60 | 6.02 | 64.97 |

Maximum Storage Required 100-year = 70 m³

2-Year Storm Event Storage Summary

| | | Water Elev. (m) = 76.5 | | | | |
|----------|-----------|------------------------|------------------------|-----------|----------|--------------------------|
| Location | INV. (in) | INV. (out) | Area (m ²) | Depth (m) | Head (m) | Volume (m ³) |
| EXCB10 | 76.30 | 74.09 | 371.9 | 0.20 | 2.43 | 20.3 |

Storage Available (m³) = 20.3
Storage Required (m³) = 19.5

5-Year Storm Event Storage Summary

| | | Water Elev. (m) = 76.53 | | | | |
|----------|-------|-------------------------|------------------------|-----------|----------|--------------------------|
| Location | T/G | INV. (out) | Area (m ²) | Depth (m) | Head (m) | Volume (m ³) |
| EXCB10 | 76.30 | 74.09 | 371.9 | 0.23 | 2.46 | 30.2 |

Storage Available (m³) = 30.2
Storage Required (m³) = 29.7

100-Year Storm Event Storage Summary

| | | Water Elev. (m) = 76.63 | | | | |
|----------|-------|-------------------------|------------------------|-----------|----------|--------------------------|
| Location | T/G | INV. (out) | Area (m ²) | Depth (m) | Head (m) | Volume (m ³) |
| EXCB10 | 76.30 | 74.09 | 637.9 | 0.33 | 2.58 | 70.8 |

Storage Available (m³) = 76.2
Storage Required (m³) = 69.9

* Available Storage calculated from AutoCAD

| Drainage Area | Area (ha) | C 2-Year | C 5-Year | C 100-Year | Tc (min) | Q (L/s) | | |
|---------------|-----------|----------|----------|------------|----------|---------|-------|-------|
| B3a | 0.17 | 0.77 | 0.77 | 0.86 | 10 | 27.54 | 37.50 | 71.84 |

| Drainage Area | Impervious Area (m ²) | Gravel (m ²) | Pervious Area (m ²) | Average C (2-year) | Average C (5-year) | Average C (100-year) |
|---------------|-----------------------------------|--------------------------|---------------------------------|--------------------|--------------------|----------------------|
| B3a | 1,367 | 0 | 321 | 0.77 | 0.77 | 0.86 |

| | |
|--------------------------------|-------|
| For Orifice Flow, C= | 0.6 |
| For Weir Flow, C= | 3.33 |
| Orifice 1 | |
| Invert Elevation | 74.07 |
| Center of Crest Elevation | 74.09 |
| Orifice Width / Weir Length | 33.00 |
| Orifice Height | NA |
| Orifice Area (m ²) | 0.001 |

ICD:
IPEX LMF50

B3a

| Elevation (m) | Orifice 1 H (m) | Q (m ³ /s) | Total Q (L/s) |
|---------------|-----------------|-----------------------|---------------|
| 74.09 | x | x | 0.0 |
| 76.34 | 2.27 | 0.003 | 3.4 |
| 76.35 | 2.28 | 0.003 | 3.4 |
| 76.36 | 2.29 | 0.003 | 3.4 |
| 76.37 | 2.30 | 0.003 | 3.4 |
| 76.38 | 2.31 | 0.003 | 3.5 |
| 76.39 | 2.32 | 0.003 | 3.5 |
| 76.40 | 2.33 | 0.003 | 3.5 |
| 76.41 | 2.34 | 0.003 | 3.5 |
| 76.42 | 2.35 | 0.003 | 3.5 |
| 76.43 | 2.36 | 0.003 | 3.5 |
| 76.44 | 2.37 | 0.003 | 3.5 |
| 76.45 | 2.38 | 0.004 | 3.5 |
| 76.46 | 2.39 | 0.004 | 3.5 |
| 76.47 | 2.40 | 0.004 | 3.5 |
| 76.48 | 2.41 | 0.004 | 3.5 |
| 76.49 | 2.42 | 0.004 | 3.5 |
| 76.50 | 2.43 | 0.004 | 3.5 |
| 76.51 | 2.44 | 0.004 | 3.5 |
| 76.52 | 2.45 | 0.004 | 3.6 |
| 76.53 | 2.46 | 0.004 | 3.6 |
| 76.54 | 2.47 | 0.004 | 3.6 |
| 76.55 | 2.48 | 0.004 | 3.6 |
| 76.56 | 2.49 | 0.004 | 3.6 |
| 76.57 | 2.50 | 0.004 | 3.6 |
| 76.58 | 2.51 | 0.004 | 3.6 |
| 76.59 | 2.52 | 0.004 | 3.6 |
| 76.60 | 2.53 | 0.004 | 3.6 |
| 76.61 | 2.54 | 0.004 | 3.6 |
| 76.62 | 2.55 | 0.004 | 3.6 |
| 76.63 | 2.56 | 0.004 | 3.6 |
| 76.64 | 2.57 | 0.004 | 3.6 |
| 76.65 | 2.58 | 0.004 | 3.6 |
| 76.66 | 2.59 | 0.004 | 3.7 |

2-year
5-year
100-year



Storage Requirements for Area B3b

2-Year Storm Event

| Tc (min) | I (mm/hr) | Runoff (L/s) B3b | Allowable Outflow (L/s) | Runoff to be Stored (L/s) | Storage Required (m ³) |
|----------|-----------|------------------|-------------------------|---------------------------|------------------------------------|
| 0 | 166.0 | 45.46 | 27.80 | 17.66 | 0.00 |
| 1 | 147.0 | 40.26 | 27.80 | 12.46 | 0.75 |
| 2 | 132.2 | 36.20 | 27.80 | 8.40 | 1.01 |
| 3 | 120.4 | 32.97 | 27.80 | 5.17 | 0.93 |
| 4 | 110.7 | 30.32 | 27.80 | 2.52 | 0.60 |

Maximum Storage Required 2-year = 1 m³

5-Year Storm Event

| Tc (min) | I (mm/hr) | Runoff (L/s) B3b | Allowable Outflow (L/s) | Runoff to be Stored (L/s) | Storage Required (m ³) |
|----------|-----------|------------------|-------------------------|---------------------------|------------------------------------|
| 0 | 230.5 | 63.13 | 28.10 | 35.03 | 0.00 |
| 5 | 141.2 | 38.67 | 28.10 | 10.57 | 3.17 |
| 10 | 104.2 | 28.54 | 28.10 | 0.44 | 0.26 |
| 15 | 83.6 | 22.89 | 28.10 | -5.21 | -4.68 |
| 20 | 70.3 | 19.25 | 28.10 | -8.85 | -10.62 |

Maximum Storage Required 5-year = 3 m³

100-Year Storm Event

| Tc (min) | I (mm/hr) | Runoff (L/s) B3b | Allowable Outflow (L/s) | Runoff to be Stored (L/s) | Storage Required (m ³) |
|----------|-----------|------------------|-------------------------|---------------------------|------------------------------------|
| 0 | 398.6 | 122.10 | 28.70 | 93.40 | 0.00 |
| 2 | 315.0 | 96.49 | 28.70 | 67.79 | 8.14 |
| 4 | 262.4 | 80.38 | 28.70 | 51.68 | 12.40 |
| 6 | 226.0 | 69.23 | 28.70 | 40.53 | 14.59 |
| 8 | 199.2 | 61.02 | 28.70 | 32.32 | 15.51 |
| 10 | 178.6 | 54.71 | 28.70 | 26.01 | 15.61 |
| 12 | 162.1 | 49.66 | 28.70 | 20.96 | 15.09 |
| 14 | 148.7 | 45.55 | 28.70 | 16.85 | 14.16 |
| 16 | 137.5 | 42.12 | 28.70 | 13.42 | 12.88 |
| 18 | 128.1 | 39.24 | 28.70 | 10.54 | 11.38 |

Maximum Storage Required 100-year = 16 m³

2-Year Storm Event Storage Summary

| Location | | INV. (in) | INV. (out) | Area (m ²) | Depth (m) | Head (m) | Volume (m ³) |
|----------|--|-----------|------------|------------------------|-----------|----------|--------------------------|
| EX CB11 | | 76.15 | 74.12 | 35.8 | 0.10 | 76.25 | 1.3 |

Storage Available (m³) = 1.3
Storage Required (m³) = 1.0

5-Year Storm Event Storage Summary

| Location | | T/G | INV. (out) | Area (m ²) | Depth (m) | Head (m) | Volume (m ³) |
|----------|--|-------|------------|------------------------|-----------|----------|--------------------------|
| EX CB11 | | 76.15 | 74.12 | 67.9 | 0.14 | 0.14 | 3.3 |

Storage Available (m³) = 3.3
Storage Required (m³) = 3.2

100-Year Storm Event Storage Summary

| Location | | T/G | INV. (out) | Area (m ²) | Depth (m) | Head (m) | Volume (m ³) |
|----------|--|-------|------------|------------------------|-----------|----------|--------------------------|
| EX CB11 | | 76.15 | 74.12 | 193.9 | 0.24 | 2.32 | 15.8 |

Storage Available (m³) = 15.8
Storage Required (m³) = 15.6

* Available Storage calculated from AutoCAD

| Drainage Area | Area (ha) | C 2-Year | C 5-Year | C 100-Year | Tc (min) | Q (L/s) | | |
|---------------|-----------|----------|----------|------------|----------|---------|-------|-------|
| B3b | 0.13 | 0.76 | 0.76 | 0.85 | 10 | 20.95 | 28.53 | 54.70 |

| Drainage Area | Impervious Area (m ²) | Gravel (m ²) | Pervious Area (m ²) | Average C (2-year) | Average C (5-year) | Average C (100-year) |
|---------------|-----------------------------------|--------------------------|---------------------------------|--------------------|--------------------|----------------------|
| B3b | 1,030 | 0 | 270 | 0.75 | 0.75 | 0.85 |

For Orifice Flow, C= 0.6
For Weir Flow, C= 3.33

| Orifice 1 | |
|--------------------------------|-------|
| Invert Elevation | 74.07 |
| Center of Crest Elevation | 74.12 |
| Orifice Width / Weir Length | 95.00 |
| Orifice Height | NA |
| Orifice Area (m ²) | 0.007 |

ICD:
IPEX TYPEA ORIFICE PLUG

B3b

| Elevation (m) | Orifice 1 (m) | H | Q (m ³ /s) | Total Q (L/s) |
|---------------|---------------|-------|-----------------------|---------------|
| 74.12 | x | x | x | 0.0 |
| 76.12 | 2.05 | 0.027 | 0.027 | 27.0 |
| 76.13 | 2.06 | 0.027 | 0.027 | 27.0 |
| 76.14 | 2.07 | 0.027 | 0.027 | 27.1 |
| 76.15 | 2.08 | 0.027 | 0.027 | 27.2 |
| 76.16 | 2.09 | 0.027 | 0.027 | 27.2 |
| 76.17 | 2.10 | 0.027 | 0.027 | 27.3 |
| 76.18 | 2.11 | 0.027 | 0.027 | 27.3 |
| 76.19 | 2.12 | 0.027 | 0.027 | 27.4 |
| 76.20 | 2.13 | 0.027 | 0.027 | 27.5 |
| 76.21 | 2.14 | 0.028 | 0.028 | 27.5 |
| 76.22 | 2.15 | 0.028 | 0.028 | 27.6 |
| 76.23 | 2.16 | 0.028 | 0.028 | 27.7 |
| 76.24 | 2.17 | 0.028 | 0.028 | 27.7 |
| 76.25 | 2.18 | 0.028 | 0.028 | 27.8 |
| 76.26 | 2.19 | 0.028 | 0.028 | 27.9 |
| 76.27 | 2.20 | 0.028 | 0.028 | 27.9 |
| 76.28 | 2.21 | 0.028 | 0.028 | 28.0 |
| 76.29 | 2.22 | 0.028 | 0.028 | 28.1 |
| 76.30 | 2.23 | 0.028 | 0.028 | 28.1 |
| 76.31 | 2.24 | 0.028 | 0.028 | 28.2 |
| 76.32 | 2.25 | 0.028 | 0.028 | 28.2 |
| 76.33 | 2.26 | 0.028 | 0.028 | 28.3 |
| 76.34 | 2.27 | 0.028 | 0.028 | 28.4 |
| 76.35 | 2.28 | 0.028 | 0.028 | 28.4 |
| 76.36 | 2.29 | 0.028 | 0.028 | 28.5 |
| 76.37 | 2.30 | 0.029 | 0.029 | 28.6 |
| 76.38 | 2.31 | 0.029 | 0.029 | 28.6 |
| 76.39 | 2.32 | 0.029 | 0.029 | 28.7 |
| 76.40 | 2.33 | 0.029 | 0.029 | 28.7 |
| 76.41 | 2.34 | 0.029 | 0.029 | 28.8 |
| 76.42 | 2.35 | 0.029 | 0.029 | 28.9 |
| 76.43 | 2.36 | 0.029 | 0.029 | 28.9 |
| 76.44 | 2.37 | 0.029 | 0.029 | 29.0 |

2-year
5-year
100-year



Storage Requirements for Area B3c

2-Year Storm Event

| Tc (min) | I (mm/hr) | Runoff (L/s) B3c | Allowable Outflow (L/s) | Runoff to be Stored (L/s) | Storage Required (m ³) |
|-----------------------------------|-----------|------------------|-------------------------|---------------------------|------------------------------------|
| 0 | 166.0 | 13.64 | 4.90 | 8.74 | 0.00 |
| 2 | 132.2 | 10.86 | 4.90 | 5.96 | 0.72 |
| 4 | 110.7 | 9.09 | 4.90 | 4.19 | 1.01 |
| 6 | 95.7 | 7.86 | 4.90 | 2.96 | 1.07 |
| 8 | 84.6 | 6.95 | 4.90 | 2.05 | 0.98 |
| 10 | | | | | |
| Maximum Storage Required 2-year = | | | | 1 | m ³ |

5-Year Storm Event

| Tc (min) | I (mm/hr) | Runoff (L/s) B3c | Allowable Outflow (L/s) | Runoff to be Stored (L/s) | Storage Required (m ³) |
|-----------------------------------|-----------|------------------|-------------------------|---------------------------|------------------------------------|
| 0 | 230.5 | 18.94 | 4.90 | 14.04 | 0.00 |
| 5 | 141.2 | 11.60 | 4.90 | 6.70 | 2.01 |
| 10 | 104.2 | 8.56 | 4.90 | 3.66 | 2.20 |
| 15 | 83.6 | 6.87 | 4.90 | 1.97 | 1.77 |
| 20 | 70.3 | 5.78 | 4.90 | 0.88 | 1.05 |
| | | | | | |
| Maximum Storage Required 5-year = | | | | 2 | m ³ |

100-Year Storm Event

| Tc (min) | I (mm/hr) | Runoff (L/s) B3c | Allowable Outflow (L/s) | Runoff to be Stored (L/s) | Storage Required (m ³) |
|-------------------------------------|-----------|------------------|-------------------------|---------------------------|------------------------------------|
| 0 | 398.6 | 36.63 | 5.00 | 31.63 | 0.00 |
| 5 | 242.7 | 22.30 | 5.00 | 17.30 | 5.19 |
| 10 | 178.6 | 16.41 | 5.00 | 11.41 | 6.85 |
| 15 | 142.9 | 13.13 | 5.00 | 8.13 | 7.32 |
| 20 | 120.0 | 11.03 | 5.00 | 6.03 | 7.23 |
| 25 | 103.8 | 9.54 | 5.00 | 4.54 | 6.81 |
| 30 | 91.9 | 8.45 | 5.00 | 3.45 | 6.20 |
| 35 | 82.6 | 7.59 | 5.00 | 2.59 | 5.44 |
| 40 | 75.1 | 6.90 | 5.00 | 1.90 | 4.56 |
| 45 | 69.1 | 6.35 | 5.00 | 1.35 | 3.65 |
| | | | | | |
| Maximum Storage Required 100-year = | | | | 7 | m ³ |

2-Year Storm Event Storage Summary

| Water Elev. (m) = 76.37 | | | | | | |
|---|-----------|------------|------------------------|-----------|----------|--------------------------|
| Location | INV. (in) | INV. (out) | Area (m ²) | Depth (m) | Head (m) | Volume (m ³) |
| CB8 | 76.30 | 73.42 | 44.4 | 0.07 | 2.97 | 1.1 |
| Storage Available (m ³) = 1.1 * | | | | | | |
| Storage Required (m ³) = 1.1 | | | | | | |

5-Year Storm Event Storage Summary

| Water Elev. (m) = 76.39 | | | | | | |
|---|-------|------------|------------------------|-----------|----------|--------------------------|
| Location | T/G | INV. (out) | Area (m ²) | Depth (m) | Head (m) | Volume (m ³) |
| CB8 | 76.30 | 73.42 | 70.7 | 0.09 | 2.99 | 2.3 |
| Storage Available (m ³) = 2.3 * | | | | | | |
| Storage Required (m ³) = 2.2 | | | | | | |

100-Year Storm Event Storage Summary

| Water Elev. (m) = 76.44 | | | | | | |
|---|-------|------------|------------------------|-----------|----------|--------------------------|
| Location | T/G | INV. (out) | Area (m ²) | Depth (m) | Head (m) | Volume (m ³) |
| CB8 | 76.30 | 73.42 | 162.8 | 0.14 | 3.04 | 7.9 |
| Storage Available (m ³) = 7.9 * | | | | | | |
| Storage Required (m ³) = 7.3 | | | | | | |

* Available Storage calculated from AutoCAD

| Drainage Area | Area (ha) | C 2-Year | C 5-Year | C 100-Year | Tc (min) | Q (L/s) | | |
|---------------|-----------|----------|----------|------------|----------|---------|------|-------|
| B3c | 0.04 | 0.76 | 0.76 | 0.85 | 10 | 6.29 | 8.56 | 16.41 |

| Drainage Area | Impervious Area (m ²) | Gravel (m ²) | Pervious Area (m ²) | Average C (2-year) | Average C (5-year) | Average C (100-year) |
|---------------|-----------------------------------|--------------------------|---------------------------------|--------------------|--------------------|----------------------|
| B3c | 355 | 0 | 35 | 0.76 | 0.76 | 0.85 |

For Orifice Flow, C= 0.6
 For Weir Flow, C= 3.33

| Orifice 1 | |
|--------------------------------|-------|
| Invert Elevation | 73.40 |
| Center of Crest Elevation | 73.42 |
| Orifice Width / Weir Length | 37.00 |
| Orifice Height | NA |
| Orifice Area (m ²) | 0.001 |

ICD:
IPEXLMF60

B3a

| Elevation (m) | Orifice 1 (m) | H | Q (m ³ /s) | Total Q (L/s) |
|---------------|---------------|-------|-----------------------|---------------|
| 73.42 | x | x | x | 0.0 |
| 76.17 | 2.77 | 0.005 | 4.8 | 4.8 |
| 76.18 | 2.78 | 0.005 | 4.8 | 4.8 |
| 76.19 | 2.79 | 0.005 | 4.8 | 4.8 |
| 76.20 | 2.80 | 0.005 | 4.8 | 4.8 |
| 76.21 | 2.81 | 0.005 | 4.8 | 4.8 |
| 76.22 | 2.82 | 0.005 | 4.8 | 4.8 |
| 76.23 | 2.83 | 0.005 | 4.8 | 4.8 |
| 76.24 | 2.84 | 0.005 | 4.8 | 4.8 |
| 76.25 | 2.85 | 0.005 | 4.8 | 4.8 |
| 76.26 | 2.86 | 0.005 | 4.8 | 4.8 |
| 76.27 | 2.87 | 0.005 | 4.8 | 4.8 |
| 76.28 | 2.88 | 0.005 | 4.8 | 4.8 |
| 76.29 | 2.89 | 0.005 | 4.9 | 4.9 |
| 76.30 | 2.90 | 0.005 | 4.9 | 4.9 |
| 76.31 | 2.91 | 0.005 | 4.9 | 4.9 |
| 76.32 | 2.92 | 0.005 | 4.9 | 4.9 |
| 76.33 | 2.93 | 0.005 | 4.9 | 4.9 |
| 76.34 | 2.94 | 0.005 | 4.9 | 4.9 |
| 76.35 | 2.95 | 0.005 | 4.9 | 4.9 |
| 76.36 | 2.96 | 0.005 | 4.9 | 4.9 |
| 76.37 | 2.97 | 0.005 | 4.9 | 4.9 |
| 76.38 | 2.98 | 0.005 | 4.9 | 4.9 |
| 76.39 | 2.99 | 0.005 | 4.9 | 4.9 |
| 76.40 | 3.00 | 0.005 | 4.9 | 4.9 |
| 76.41 | 3.01 | 0.005 | 5.0 | 5.0 |
| 76.42 | 3.02 | 0.005 | 5.0 | 5.0 |
| 76.43 | 3.03 | 0.005 | 5.0 | 5.0 |
| 76.44 | 3.04 | 0.005 | 5.0 | 5.0 |
| 76.45 | 3.05 | 0.005 | 5.0 | 5.0 |
| 76.46 | 3.06 | 0.005 | 5.0 | 5.0 |
| 76.47 | 3.07 | 0.005 | 5.0 | 5.0 |
| 76.48 | 3.08 | 0.005 | 5.0 | 5.0 |
| 76.49 | 3.09 | 0.005 | 5.0 | 5.0 |

2-year
5-year
100-year

| Drainage Area | Area (ha) | C 2-Year | C 5-Year | C 100-Year | Tc (min) | Q (L/s) | | |
|---------------|-----------|----------|----------|------------|----------|---------|--------|----------|
| | | | | | | 2-Year | 5-Year | 100-Year |
| B3d | 0.26 | 0.62 | 0.62 | 0.70 | 10 | 34.10 | 46.43 | 89.86 |

| Drainage Area | Impervious Area (m ²) | Gravel (m ²) | Pervious Area (m ²) | Average C (2-year) | Average C (5-year) | Average C (100-year) |
|---------------|-----------------------------------|--------------------------|---------------------------------|--------------------|--------------------|----------------------|
| B3d | 1,547 | 0 | 1,053 | 0.62 | 0.62 | 0.70 |

* No Proposed Storage



Time of Concentration Pre-Development

| Drainage Area ID | Sheet Flow Distance (m) | Slope of Land (%) | Tc (min) (5-Year) | Tc (min) (100-Year) |
|------------------|-------------------------|-------------------|-------------------|---------------------|
| A1 | 130 | 2.00 | 10 | 8 |

Therefore, a Tc of 10 can be used

$$T_c = (3.26(1.1-c)L^{0.5}/S^{0.33})$$

c = Balanced Runoff Coefficient

L = Length of drainage area

S = Average slope of watershed

STORM SEWER DESIGN SHEET

PROJECT: CCO-22-1241
 LOCATION: 2025 Othello Avenue
 CLIENT: Osgoode Properties



| LOCATION | | | | CONTRIBUTING AREA (ha) | | | | RATIONAL DESIGN FLOW | | | | | | | | | | SEWER DATA | | | | | | | | | | |
|-------------|---------|----------|-------------------|------------------------|------|----------|----------|----------------------|--------------|-------------|---------------|----------------|-----------------|---------------------|----------------------|-----------------------|------------------|-------------------|----------------|------------|----------------|-----|----|-----------|----------------|-----------------|--------|--|
| 1 | 2 | 3 | 4 | 5 | 6 | 7 | 8 | 9 | 10 | 11 | 12 | 13 | 14 | 15 | 16 | 17 | 18 | 19 | 20 | 21 | 22 | 23 | 24 | 25 | 26 | 27 | 28 | |
| LOCATION | AREA ID | FROM MH | TO MH | C-VALUE | AREA | INDIV AC | CUMUL AC | INLET (min) | TIME IN PIPE | TOTAL (min) | i (5) (mm/hr) | i (10) (mm/hr) | i (100) (mm/hr) | 5yr PEAK FLOW (L/s) | 10yr PEAK FLOW (L/s) | 100yr PEAK FLOW (L/s) | FIXED FLOW (L/s) | DESIGN FLOW (L/s) | CAPACITY (L/s) | LENGTH (m) | PIPE SIZE (mm) | | | SLOPE (%) | VELOCITY (m/s) | AVAIL CAP (5yr) | | |
| | | | | | | | | | | | | | | | | | | | | | | DIA | W | H | | | | |
| W Parking | B1a | CB1 | STMH2 | 0.75 | 0.05 | 0.04 | 0.04 | 10.00 | 0.23 | 10.23 | 104.19 | 122.14 | 178.56 | 10.75 | 12.61 | 18.43 | | 10.75 | 58.20 | 15.85 | 250 | | | 0.88 | 1.149 | 47.44 | 81.52% | |
| W Parking | B1a | STMH2 | CBMH3 | | | | 0.04 | 10.23 | 0.24 | 10.47 | 102.99 | 120.73 | 176.48 | 10.63 | 12.46 | 18.21 | | 10.63 | 62.35 | 17.36 | 250 | | | 1.01 | 1.230 | 51.72 | 82.95% | |
| W Parking | B1a | CBMH3 | CBMH4 | 0.70 | 0.10 | 0.07 | 0.10 | 10.47 | 0.16 | 10.62 | 101.80 | 119.32 | 174.42 | 29.52 | 34.61 | 50.58 | | 29.52 | 100.88 | 13.00 | 300 | | | 1.00 | 1.383 | 71.36 | 70.73% | |
| W Parking | B1a | CBMH4 | STMH2 | 0.76 | 0.08 | 0.06 | 0.17 | 10.62 | 0.08 | 10.71 | 101.02 | 118.40 | 173.07 | 46.59 | 54.60 | 79.81 | 10.20 | 10.20 | 100.88 | 7.02 | 300 | | | 1.00 | 1.383 | 90.68 | 89.89% | |
| W Parking | B1b | CB6 | EX CB3 | 0.80 | 0.06 | 0.05 | 0.05 | 10.00 | 0.31 | 10.31 | 104.19 | 122.14 | 178.56 | 13.44 | 15.76 | 23.03 | | 13.44 | 59.51 | 21.82 | 250 | | | 0.92 | 1.174 | 46.07 | 77.41% | |
| W Parking | B1b | EX CB3 | EX PIPE | 0.80 | 0.05 | 0.04 | 0.08 | 10.31 | 0.04 | 10.35 | 102.59 | 120.25 | 175.78 | 24.09 | 28.24 | 41.28 | 13.30 | 13.30 | 15.89 | 1.87 | 150 | | | 1.00 | 0.871 | 2.59 | 16.29% | |
| W Parking | B1d | EX CB2 | EX PIPE | 0.76 | 0.07 | 0.06 | 0.06 | 10.00 | 0.04 | 10.04 | 104.19 | 122.14 | 178.56 | 16.07 | 18.84 | 27.54 | 5.00 | 5.00 | 15.89 | 1.90 | 150 | | | 1.00 | 0.871 | 10.89 | 68.53% | |
| W Parking | B1c | EX CB1 | EX PIPE | 0.65 | 0.06 | 0.04 | 0.04 | 10.04 | 0.04 | 10.07 | 104.00 | 121.92 | 178.23 | 10.90 | 12.78 | 18.68 | 4.90 | 4.90 | 15.89 | 1.92 | 150 | | | 1.00 | 0.871 | 10.99 | 69.16% | |
| W Parking | B1 | STMH5 | OGS1 | | | | 0.34 | 10.00 | 1.05 | 11.05 | 104.19 | 122.14 | 178.56 | 99.51 | 116.65 | 170.53 | 33.40 | 33.40 | 55.14 | 68.70 | 250 | | | 0.79 | 1.088 | 21.74 | 39.43% | |
| W Parking | B1 | OGS1 | EX MH | | | | 0.34 | 11.05 | 0.09 | 11.14 | 98.95 | 115.96 | 169.48 | 94.50 | 110.75 | 161.86 | 33.40 | 33.40 | 55.14 | 5.70 | 250 | | | 0.79 | 1.088 | 21.74 | 39.43% | |
| W Parking | B1 | EX MH | PLEASANT PARK | | | | 0.34 | 11.14 | 0.19 | 11.33 | 98.54 | 115.48 | 168.77 | 94.11 | 110.29 | 161.19 | 33.40 | 33.40 | 55.14 | 12.28 | 250 | | | 0.79 | 1.088 | 21.74 | 39.43% | |
| E Parking | B2a | CB12 | CBMH10 | 0.80 | 0.13 | 0.11 | 0.11 | 10.00 | 0.22 | 10.22 | 104.19 | 122.14 | 178.56 | 30.94 | 36.26 | 53.01 | | 30.94 | 62.04 | 16.40 | 250 | | | 1.00 | 1.224 | 31.10 | 50.14% | |
| E Parking | B2a | CBMH10 | CBMH11 | 0.80 | 0.10 | 0.08 | 0.18 | 10.22 | 0.68 | 10.90 | 103.03 | 120.77 | 176.54 | 52.66 | 61.72 | 90.23 | | 52.66 | 62.04 | 49.95 | 250 | | | 1.00 | 1.224 | 9.38 | 15.13% | |
| E Parking | B2a | CB13 | CBMH11 | 0.80 | 0.16 | 0.13 | 0.13 | 10.00 | 0.22 | 10.22 | 104.19 | 122.14 | 178.56 | 36.27 | 42.51 | 62.15 | | 36.27 | 62.04 | 16.40 | 250 | | | 1.00 | 1.224 | 25.77 | 41.54% | |
| E Parking | B2a | CBMH11 | EX CB7 | 0.80 | 0.10 | 0.08 | 0.39 | 10.90 | 0.18 | 11.08 | 99.65 | 116.79 | 170.70 | 107.78 | 126.32 | 184.62 | | 107.78 | 182.91 | 16.95 | 375 | | | 1.00 | 1.604 | 75.13 | 41.08% | |
| E Parking | B2a | EX CB8 | EX CB7 | 0.25 | 0.06 | 0.01 | 0.01 | 10.00 | 0.39 | 10.39 | 104.19 | 122.14 | 178.56 | 3.98 | 4.67 | 6.83 | | 3.98 | 16.66 | 21.19 | 150 | | | 1.10 | 0.913 | 12.68 | 76.10% | |
| E Parking | B2a | EX CB6 | EX CB7 | 0.50 | 0.03 | 0.02 | 0.02 | 10.00 | 0.43 | 10.43 | 104.19 | 122.14 | 178.56 | 4.78 | 5.60 | 8.19 | | 4.78 | 18.66 | 26.70 | 150 | | | 1.38 | 1.023 | 13.88 | 74.39% | |
| E Parking | B2a | EX CB7 | EX MH | 0.50 | 0.04 | 0.02 | 0.44 | 11.08 | 0.35 | 11.43 | 98.82 | 115.81 | 169.26 | 120.13 | 140.79 | 205.76 | 13.70 | 13.70 | 72.88 | 29.90 | 250 | | | 1.38 | 1.438 | 59.18 | 81.20% | |
| EX BUILDING | B4 | EX BLDG | EX MH | 0.90 | 0.15 | 0.14 | 0.14 | 10.00 | 0.09 | 10.09 | 104.19 | 122.14 | 178.56 | 39.10 | 45.84 | 67.01 | | 39.10 | 72.88 | 7.63 | 250 | | | 1.38 | 1.438 | 33.78 | 46.34% | |
| E Parking | B2b | RAMP CB | EX PIPE | 0.88 | 0.01 | 0.01 | 0.01 | 10.00 | 0.14 | 10.14 | 104.19 | 122.14 | 178.56 | 2.47 | 2.90 | 4.24 | | 2.47 | 72.88 | 12.48 | 250 | | | 1.38 | 1.438 | 70.41 | 96.61% | |
| E Parking | B2b | EX CB5 | EX PIPE | 0.55 | 0.04 | 0.02 | 0.02 | 10.00 | 0.01 | 10.01 | 104.19 | 122.14 | 178.56 | 5.58 | 6.54 | 9.56 | | 5.58 | 72.88 | 1.02 | 250 | | | 1.38 | 1.438 | 67.30 | 92.35% | |
| E Parking | B2b | EX CB4 | EX PIPE | 0.55 | 0.04 | 0.02 | 0.04 | 10.00 | 0.03 | 10.03 | 104.19 | 122.14 | 178.56 | 11.95 | 14.01 | 20.48 | | 11.95 | 72.88 | 2.61 | 250 | | | 1.38 | 1.438 | 60.93 | 83.61% | |
| E Parking | B2 | EX MH | OGS2 | | | | 0.64 | 10.00 | 0.59 | 10.59 | 104.19 | 122.14 | 178.56 | 185.76 | 217.76 | 318.35 | | 72.80 | 72.88 | 50.86 | 250 | | | 1.38 | 1.438 | 0.08 | 0.11% | |
| E Parking | B2 | OGS2 | PLEASANT PARK | | | | 0.64 | 10.59 | 0.14 | 10.73 | 101.18 | 118.59 | 173.34 | 180.39 | 211.44 | 309.05 | | 72.80 | 72.88 | 11.77 | 250 | | | 1.38 | 1.438 | 0.08 | 0.11% | |
| N Parking | B3a | CB9 | EX CB10 | 0.78 | 0.07 | 0.06 | 0.06 | 10.00 | 0.29 | 10.29 | 104.19 | 122.14 | 178.56 | 16.49 | 19.33 | 28.26 | | 16.49 | 63.27 | 22.03 | 250 | | | 1.04 | 1.249 | 46.77 | 73.93% | |
| N Parking | B3d | EX CB9 | EX PIPE | 0.20 | 0.06 | 0.01 | 0.01 | 10.00 | 0.31 | 10.31 | 104.19 | 122.14 | 178.56 | 3.56 | 4.18 | 6.11 | | 3.56 | 14.21 | 14.58 | 150 | | | 0.80 | 0.779 | 10.65 | 74.93% | |
| N Parking | B3b | EX CB11 | EX PIPE | 0.85 | 0.13 | 0.11 | 0.11 | 10.00 | 0.06 | 10.06 | 104.19 | 122.14 | 178.56 | 32.75 | 38.39 | 56.12 | 28.70 | 28.70 | 30.97 | 5.70 | 150 | | | 3.80 | 1.698 | 2.27 | 7.33% | |
| N Parking | B3d | RAMP CB | EX PIPE | 0.90 | 0.01 | 0.01 | 0.01 | 10.00 | 0.33 | 10.33 | 104.19 | 122.14 | 178.56 | 2.40 | 2.81 | 4.11 | | 2.40 | 14.21 | 15.63 | 150 | | | 0.80 | 0.779 | 11.81 | 83.12% | |
| N Parking | B3 | EX CB 10 | EX MH | 0.84 | 0.09 | 0.08 | 0.27 | 10.33 | 0.83 | 11.16 | 102.46 | 120.10 | 175.56 | 75.81 | 88.87 | 129.91 | 38.26 | 38.26 | 56.86 | 55.64 | 250 | | | 0.84 | 1.122 | 18.60 | 32.71% | |
| EX BUILDING | B3 | BLDG | EX MH | 0.90 | 0.15 | 0.14 | 0.14 | 10.00 | 0.11 | 10.11 | 104.19 | 122.14 | 178.56 | 39.10 | 45.84 | 67.01 | | 39.10 | 73.41 | 9.91 | 250 | | | 1.40 | 1.449 | 34.30 | 46.73% | |
| N Parking | B3 | EX CB12 | PROP PIPE | 0.79 | 0.12 | 0.09 | 0.09 | 10.00 | 0.06 | 10.06 | 104.19 | 122.14 | 178.56 | 26.66 | 31.25 | 45.69 | | 26.66 | 73.41 | 4.85 | 250 | | | 1.40 | 1.449 | 46.75 | 63.68% | |
| N Parking | B3 | CB8 | CBMH7 | 0.88 | 0.04 | 0.03 | 0.03 | 10.00 | 0.13 | 10.13 | 104.19 | 122.14 | 178.56 | 9.94 | 11.65 | 17.04 | | 9.94 | 62.66 | 9.80 | 250 | | | 1.02 | 1.237 | 52.72 | 84.13% | |
| N Parking | B3 | CBMH7 | EX PIPE | 0.77 | 0.07 | 0.05 | 0.09 | 10.13 | 0.01 | 10.14 | 103.50 | 121.33 | 177.36 | 25.25 | 29.60 | 43.27 | | 25.25 | 145.49 | 1.23 | 250 | | | 5.50 | 2.871 | 120.24 | 82.64% | |
| N Parking | B3 | EX MH | OGS | | | | 0.58 | 11.16 | 0.62 | 11.79 | 98.44 | 115.36 | 168.60 | 158.98 | 186.32 | 272.30 | 110.89 | 110.89 | 173.52 | 57.05 | 375 | | | 0.90 | 1.522 | 62.63 | 36.10% | |
| N Parking | B3 | OGS | EX MH | | | | 0.58 | 11.79 | 0.02 | 11.80 | 95.62 | 112.05 | 163.73 | 154.44 | 180.97 | 264.44 | | 110.89 | 173.52 | 1.38 | 375 | | | 0.90 | 1.522 | 62.63 | 36.10% | |
| N Parking | B3 | EX MH | PROP MH (OTHELLO) | | | | 0.58 | 11.80 | 0.07 | 11.87 | 95.56 | 111.97 | 163.62 | 154.33 | 180.84 | 264.26 | | 110.89 | 139.06 | 8.05 | 300 | | | 1.90 | 1.906 | 28.17 | 20.26% | |

Definitions:
 Q = 2.78CIA, where:
 Q = Peak Flow in Litres per Second (L/s)
 A = Area in Hectares (ha)
 i = Rainfall intensity in millimeters per hour (mm/hr)
 [i = 998.071 / (TC+6.053)^0.814] 5 YEAR
 [i = 1174.184 / (TC+6.014)^0.816] 10 YEAR
 [i = 1735.688 / (TC+6.014)^0.820] 100 YEAR

Notes:
 1. Mannings coefficient (n) = 0.013

Designed:
 No. 1. Revision Issued for Site Plan Application Date: 2025.09.09

M.R.

Checked:

JB

Project No.:
 CCO-22-1241

Date:
 2025.09.09

Sheet No.:
 1 of 1

Imbrium® Systems
ESTIMATED NET ANNUAL SEDIMENT (TSS) LOAD REDUCTION

12/11/2025

| | |
|---------------------------|----------------|
| Province: | Ontario |
| City: | Ottawa |
| Nearest Rainfall Station: | OTTAWA CDA RCS |
| Climate Station Id: | 6105978 |
| Years of Rainfall Data: | 20 |

| | |
|-------------------|-------------------------------|
| Project Name: | Othello |
| Project Number: | 69584 |
| Designer Name: | ROBBIE PICKARD |
| Designer Company: | EGIS |
| Designer Email: | robert.pickard@egis-group.com |
| Designer Phone: | 613-808-3427 |
| EOR Name: | |
| EOR Company: | |
| EOR Email: | |
| EOR Phone: | |

| | |
|-------------------------|------|
| Site Name: | OGSI |
| Drainage Area (ha): | 0.47 |
| Runoff Coefficient 'c': | 0.79 |

| | |
|-----------------------------|------|
| Particle Size Distribution: | Fine |
| Target TSS Removal (%): | 80.0 |

| | |
|--|--------|
| Required Water Quality Runoff Volume Capture (%): | 90.00 |
| Estimated Water Quality Flow Rate (L/s): | 11.98 |
| Oil / Fuel Spill Risk Site? | Yes |
| Upstream Flow Control? | Yes |
| Upstream Orifice Control Flow Rate to Stormceptor (L/s): | 33.40 |
| Peak Conveyance (maximum) Flow Rate (L/s): | 183.88 |
| Influent TSS Concentration (mg/L): | 200 |
| Estimated Average Annual Sediment Load (kg/yr): | 454 |
| Estimated Average Annual Sediment Volume (L/yr): | 369 |

| Net Annual Sediment (TSS) Load Reduction Sizing Summary | |
|---|--------------------------|
| Stormceptor Model | TSS Removal Provided (%) |
| EFO4 | 87 |
| EFO5 | 91 |
| EFO6 | 94 |
| EFO8 | 97 |
| EFO10 | 99 |
| EFO12 | 100 |

Recommended Stormceptor EFO Model: EFO4
Estimated Net Annual Sediment (TSS) Load Reduction (%): 87
Water Quality Runoff Volume Capture (%): > 90



THIRD-PARTY TESTING AND VERIFICATION

► **Stormceptor® EF and Stormceptor® EFO** are the latest evolutions in the Stormceptor® oil-grit separator (OGS) technology series, and are designed to remove a wide variety of pollutants from stormwater and snowmelt runoff. These technologies have been third-party tested in accordance with the Canadian ETV **Procedure for Laboratory Testing of Oil-Grit Separators** and performance has been third-party verified in accordance with the **ISO 14034 Environmental Technology Verification (ETV)** protocol.

PERFORMANCE

► **Stormceptor® EF and EFO** remove stormwater pollutants through gravity separation and floatation, and feature a patent-pending design that generates positive removal of total suspended solids (TSS) throughout each storm event, including high-intensity storms. Captured pollutants include sediment, free oils, and sediment-bound pollutants such as nutrients, heavy metals, and petroleum hydrocarbons. Stormceptor is sized to remove a high level of TSS from the frequent rainfall events that contribute the vast majority of annual runoff volume and pollutant load. The technology incorporates an internal bypass to convey excessive stormwater flows from high-intensity storms through the device without resuspension and washout (scour) of previously captured pollutants. Proper routine maintenance ensures high pollutant removal performance and protection of downstream waterways.

PARTICLE SIZE DISTRIBUTION (PSD)

► The **Canadian ETV PSD** shown in the table below was used, or in part, for this sizing. This is the identical PSD that is referenced in the Canadian ETV **Procedure for Laboratory Testing of Oil-Grit Separators** for both sediment removal testing and scour testing. The Canadian ETV PSD contains a wide range of particle sizes in the sand and silt fractions, and is considered reasonably representative of the particle size fractions found in typical urban stormwater runoff.

| Particle Size (µm) | Percent Less Than | Particle Size Fraction (µm) | Percent |
|--------------------|-------------------|-----------------------------|---------|
| 1000 | 100 | 500-1000 | 5 |
| 500 | 95 | 250-500 | 5 |
| 250 | 90 | 150-250 | 15 |
| 150 | 75 | 100-150 | 15 |
| 100 | 60 | 75-100 | 10 |
| 75 | 50 | 50-75 | 5 |
| 50 | 45 | 20-50 | 10 |
| 20 | 35 | 8-20 | 15 |
| 8 | 20 | 5-8 | 10 |
| 5 | 10 | 2-5 | 5 |
| 2 | 5 | <2 | 5 |

Upstream Flow Controlled Results

| Rainfall Intensity (mm / hr) | Percent Rainfall Volume (%) | Cumulative Rainfall Volume (%) | Flow Rate (L/s) | Flow Rate (L/min) | Surface Loading Rate (L/min/m ²) | Removal Efficiency (%) | Incremental Removal (%) | Cumulative Removal (%) |
|---|-----------------------------|--------------------------------|-----------------|-------------------|--|------------------------|-------------------------|------------------------|
| 0.50 | 8.6 | 8.6 | 0.52 | 31.0 | 26.0 | 100 | 8.6 | 8.6 |
| 1.00 | 20.3 | 29.0 | 1.03 | 62.0 | 52.0 | 100 | 20.3 | 29.0 |
| 2.00 | 16.2 | 45.2 | 2.06 | 124.0 | 103.0 | 96 | 15.6 | 44.5 |
| 3.00 | 12.0 | 57.2 | 3.10 | 186.0 | 155.0 | 89 | 10.7 | 55.3 |
| 4.00 | 8.4 | 65.6 | 4.13 | 248.0 | 206.0 | 83 | 7.0 | 62.3 |
| 5.00 | 5.9 | 71.6 | 5.16 | 310.0 | 258.0 | 81 | 4.8 | 67.1 |
| 6.00 | 4.6 | 76.2 | 6.19 | 372.0 | 310.0 | 78 | 3.6 | 70.7 |
| 7.00 | 3.1 | 79.3 | 7.23 | 434.0 | 361.0 | 76 | 2.3 | 73.0 |
| 8.00 | 2.7 | 82.0 | 8.26 | 495.0 | 413.0 | 73 | 2.0 | 75.0 |
| 9.00 | 3.3 | 85.3 | 9.29 | 557.0 | 464.0 | 71 | 2.4 | 77.4 |
| 10.00 | 2.3 | 87.6 | 10.32 | 619.0 | 516.0 | 69 | 1.6 | 79.0 |
| 11.00 | 1.6 | 89.2 | 11.35 | 681.0 | 568.0 | 66 | 1.0 | 80.0 |
| 12.00 | 1.3 | 90.5 | 12.39 | 743.0 | 619.0 | 64 | 0.9 | 80.8 |
| 13.00 | 1.7 | 92.2 | 13.42 | 805.0 | 671.0 | 64 | 1.1 | 82.0 |
| 14.00 | 1.2 | 93.5 | 14.45 | 867.0 | 723.0 | 64 | 0.8 | 82.7 |
| 15.00 | 1.2 | 94.6 | 15.48 | 929.0 | 774.0 | 63 | 0.7 | 83.5 |
| 16.00 | 0.7 | 95.3 | 16.52 | 991.0 | 826.0 | 63 | 0.4 | 83.9 |
| 17.00 | 0.7 | 96.1 | 17.55 | 1053.0 | 877.0 | 63 | 0.5 | 84.4 |
| 18.00 | 0.4 | 96.5 | 18.58 | 1115.0 | 929.0 | 62 | 0.2 | 84.6 |
| 19.00 | 0.4 | 96.9 | 19.61 | 1177.0 | 981.0 | 62 | 0.3 | 84.9 |
| 20.00 | 0.2 | 97.1 | 20.64 | 1239.0 | 1032.0 | 61 | 0.1 | 85.0 |
| 21.00 | 0.5 | 97.5 | 21.68 | 1301.0 | 1084.0 | 60 | 0.3 | 85.3 |
| 22.00 | 0.2 | 97.8 | 22.71 | 1363.0 | 1135.0 | 59 | 0.1 | 85.4 |
| 23.00 | 1.0 | 98.8 | 23.74 | 1424.0 | 1187.0 | 57 | 0.6 | 86.0 |
| 24.00 | 0.3 | 99.1 | 24.77 | 1486.0 | 1239.0 | 56 | 0.2 | 86.1 |
| 25.00 | 0.0 | 99.1 | 25.81 | 1548.0 | 1290.0 | 55 | 0.0 | 86.1 |
| 30.00 | 0.9 | 100.0 | 30.97 | 1858.0 | 1548.0 | 48 | 0.4 | 86.6 |
| 35.00 | 0.0 | 100.0 | 33.00 | 1980.0 | 1650.0 | 44 | 0.0 | 86.6 |
| 40.00 | 0.0 | 100.0 | 33.00 | 1980.0 | 1650.0 | 44 | 0.0 | 86.6 |
| 45.00 | 0.0 | 100.0 | 33.00 | 1980.0 | 1650.0 | 44 | 0.0 | 86.6 |
| Estimated Net Annual Sediment (TSS) Load Reduction = | | | | | | | | 87 % |

Climate Station ID: 6105978 Years of Rainfall Data: 20

RAINFALL DATA FROM OTTAWA CDA RCS RAINFALL STATION

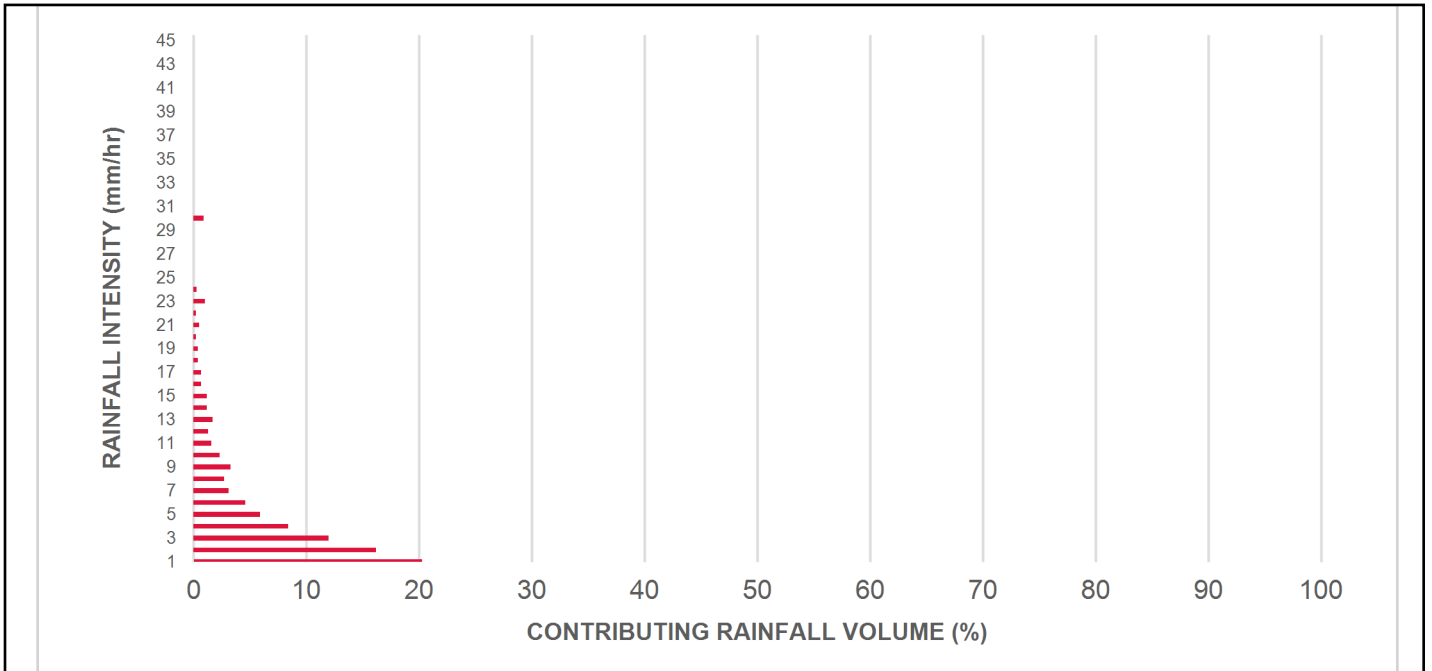

INCREMENTAL AND CUMULATIVE TSS REMOVAL FOR THE RECOMMENDED STORMCEPTOR® MODEL

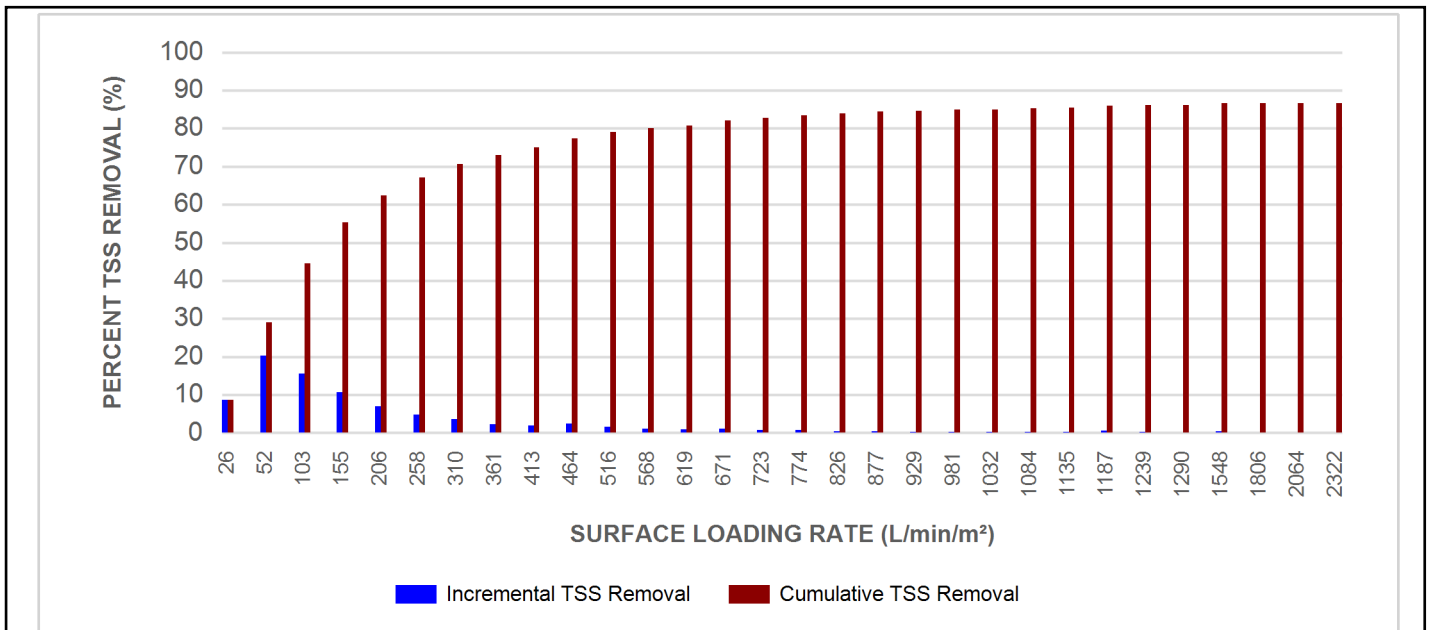

Maximum Pipe Diameter / Peak Conveyance

| Stormceptor EF / EFO | Model Diameter | | Min Angle Inlet / Outlet Pipes | Max Inlet Pipe Diameter | | Max Outlet Pipe Diameter | | Peak Conveyance Flow Rate | |
|-------------------------|----------------|------|-----------------------------------|----------------------------|------|-----------------------------|------|------------------------------|-------|
| | (m) | (ft) | | (mm) | (in) | (mm) | (in) | (L/s) | (cfs) |
| EF4 / EFO4 | 1.2 | 4 | 90 | 609 | 24 | 609 | 24 | 425 | 15 |
| EF5 / EFO5 | 1.5 | 5 | 90 | 762 | 30 | 762 | 30 | 710 | 25 |
| EF6 / EFO6 | 1.8 | 6 | 90 | 914 | 36 | 914 | 36 | 990 | 35 |
| EF8 / EFO8 | 2.4 | 8 | 90 | 1219 | 48 | 1219 | 48 | 1700 | 60 |
| EF10 / EFO10 | 3.0 | 10 | 90 | 1828 | 72 | 1828 | 72 | 2830 | 100 |
| EF12 / EFO12 | 3.6 | 12 | 90 | 1828 | 72 | 1828 | 72 | 2830 | 100 |

SCOUR PREVENTION AND ONLINE CONFIGURATION

► Stormceptor® EF and EFO feature an internal bypass and superior scour prevention technology that have been demonstrated in third-party testing according to the scour testing provisions of the Canadian ETV **Procedure for Laboratory Testing of Oil-Grit Separators**, and the exceptional scour test performance has been third-party verified in accordance with the ISO 14034 ETV protocol. As a result, Stormceptor EF and EFO are approved for online installation, eliminating the need for costly additional bypass structures, piping, and installation expense.

DESIGN FLEXIBILITY

► Stormceptor® EF and EFO offers design flexibility in one simplified platform, accepting stormwater flow from a single inlet pipe or multiple inlet pipes, and/or surface runoff through an inlet grate. The device can also serve as a junction structure, accommodate a 90-degree inlet-to-outlet bend angle, and can be modified to ensure performance in submerged conditions.

OIL CAPTURE AND RETENTION

► While Stormceptor® EF will capture and retain oil from dry weather spills and low intensity runoff, Stormceptor® EFO has demonstrated superior oil capture and greater than 99% oil retention in third-party testing according to the light liquid re-entrainment testing provisions of the Canadian ETV **Procedure for Laboratory Testing of Oil-Grit Separators**. Stormceptor EFO is recommended for sites where oil capture and retention is a requirement.

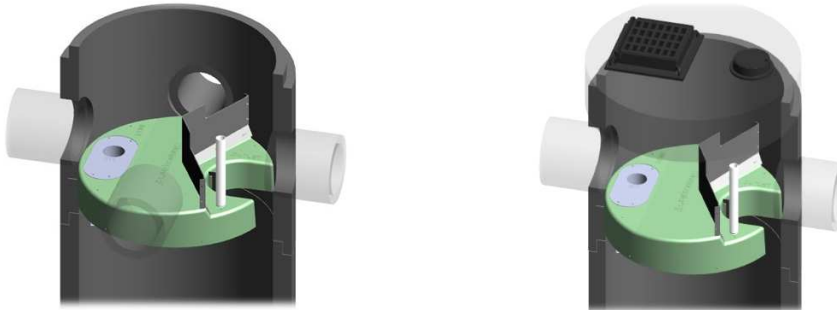

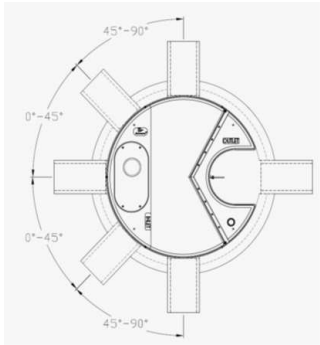

INLET-TO-OUTLET DROP

Elevation differential between inlet and outlet pipe inverts is dictated by the angle at which the inlet pipe(s) enters the unit.

0° - 45° : The inlet pipe is 1-inch (25mm) higher than the outlet pipe.

45° - 90° : The inlet pipe is 2-inches (50mm) higher than the outlet pipe.

HEAD LOSS

The head loss through Stormceptor EF is similar to that of a 60-degree bend structure. The applicable K value for calculating minor losses through the unit is 1.1. For submerged conditions the applicable K value is 3.0.

Pollutant Capacity

| Stormceptor EF / EFO | Model Diameter | | Depth (Outlet Pipe Invert to Sump Floor) | | Oil Volume | | Recommended Sediment Maintenance Depth * | | Maximum Sediment Volume * | | Maximum Sediment Mass ** | |
|----------------------|----------------|------|--|------|------------|-------|--|------|---------------------------|--------------------|--------------------------|--------|
| | (m) | (ft) | (m) | (ft) | (L) | (Gal) | (mm) | (in) | (L) | (ft ³) | (kg) | (lb) |
| EF4 / EFO4 | 1.2 | 4 | 1.52 | 5.0 | 265 | 70 | 203 | 8 | 1190 | 42 | 1904 | 5250 |
| EF5 / EFO5 | 1.5 | 5 | 1.62 | 5.3 | 420 | 111 | 305 | 10 | 2124 | 75 | 2612 | 5758 |
| EF6 / EFO6 | 1.8 | 6 | 1.93 | 6.3 | 610 | 160 | 305 | 12 | 3470 | 123 | 5552 | 15375 |
| EF8 / EFO8 | 2.4 | 8 | 2.59 | 8.5 | 1070 | 280 | 610 | 24 | 8780 | 310 | 14048 | 38750 |
| EF10 / EFO10 | 3.0 | 10 | 3.25 | 10.7 | 1670 | 440 | 610 | 24 | 17790 | 628 | 28464 | 78500 |
| EF12 / EFO12 | 3.6 | 12 | 3.89 | 12.8 | 2475 | 655 | 610 | 24 | 31220 | 1103 | 49952 | 137875 |

*Increased sump depth may be added to increase sediment storage capacity

** Average density of wet packed sediment in sump = 1.6 kg/L (100 lb/ft³)

| Feature | Benefit | Feature Appeals To |
|---|---|---|
| Patent-pending enhanced flow treatment and scour prevention technology | Superior, verified third-party performance | Regulator, Specifying & Design Engineer |
| Third-party verified light liquid capture and retention for EFO version | Proven performance for fuel/oil hotspot locations | Regulator, Specifying & Design Engineer, Site Owner |
| Functions as bend, junction or inlet structure | Design flexibility | Specifying & Design Engineer |
| Minimal drop between inlet and outlet | Site installation ease | Contractor |
| Large diameter outlet riser for inspection and maintenance | Easy maintenance access from grade | Maintenance Contractor & Site Owner |

STANDARD STORMCEPTOR EF/EFO DRAWINGS

For standard details, please visit <http://www.imbriumsystems.com/stormwater-treatment-solutions/stormceptor-ef>

STANDARD STORMCEPTOR EF/EFO SPECIFICATION

For specifications, please visit <http://www.imbriumsystems.com/stormwater-treatment-solutions/stormceptor-ef>

STANDARD PERFORMANCE SPECIFICATION FOR “OIL GRIT SEPARATOR” (OGS) STORMWATER QUALITY TREATMENT DEVICE

PART 1 – GENERAL

1.1 WORK INCLUDED

This section specifies requirements for selecting, sizing, and designing an underground Oil Grit Separator (OGS) device for stormwater quality treatment, with third-party testing results and a Statement of Verification in accordance with ISO 14034 Environmental Management – Environmental Technology Verification (ETV).

1.2 REFERENCE STANDARDS & PROCEDURES

ISO 14034:2016 Environmental management – Environmental technology verification (ETV)

Canadian Environmental Technology Verification (ETV) Program’s **Procedure for Laboratory Testing of Oil-Grit Separators**

1.3 SUBMITTALS

1.3.1 All submittals, including sizing reports & shop drawings, shall be submitted upon request with each order to the contractor then forwarded to the Engineer of Record for review and acceptance. Shop drawings shall detail all OGS components, elevations, and sequence of construction.

1.3.2 Alternative devices shall have features identical to or greater than the specified device, including: treatment chamber diameter, treatment chamber wet volume, sediment storage volume, and oil storage volume.

1.3.3 Unless directed otherwise by the Engineer of Record, OGS stormwater quality treatment product substitutions or alternatives submitted within ten days prior to project bid shall not be accepted. All alternatives or substitutions submitted shall be signed and sealed by a local registered Professional Engineer, based on the exact same criteria detailed in Section 3, in entirety, subject to review and approval by the Engineer of Record.

PART 2 – PRODUCTS

2.1 OGS POLLUTANT STORAGE

The OGS device shall include a sump for sediment storage, and a protected volume for the capture and storage of petroleum hydrocarbons and buoyant gross pollutants. The minimum sediment & petroleum hydrocarbon storage capacity shall be as follows:

| | | |
|-------|-------------------------------------|---|
| 2.1.1 | 4 ft (1219 mm) Diameter OGS Units: | 1.19 m ³ sediment / 265 L oil |
| | 5 ft (1524 mm) Diameter OGS Units: | 1.95 m ³ sediment / 420 L oil |
| | 6 ft (1829 mm) Diameter OGS Units: | 3.48 m ³ sediment / 609 L oil |
| | 8 ft (2438 mm) Diameter OGS Units: | 8.78 m ³ sediment / 1,071 L oil |
| | 10 ft (3048 mm) Diameter OGS Units: | 17.78 m ³ sediment / 1,673 L oil |
| | 12 ft (3657 mm) Diameter OGS Units: | 31.23 m ³ sediment / 2,476 L oil |

PART 3 – PERFORMANCE & DESIGN

3.1 GENERAL

The OGS stormwater quality treatment device shall be verified in accordance with ISO 14034:2016 Environmental management – Environmental technology verification (ETV). The OGS stormwater quality treatment device shall remove oil, sediment and gross pollutants from stormwater runoff during frequent wet weather events, and retain these pollutants during less frequent high flow wet weather events below the insert within the OGS for later removal during maintenance. The Manufacturer shall have at least ten (10) years of local experience, history and success in engineering design, manufacturing and production and supply of OGS stormwater quality treatment device systems, acceptable to the Engineer of Record.

3.2 SIZING METHODOLOGY

The OGS device shall be engineered, designed and sized to provide stormwater quality treatment based on treating a minimum of 90 percent of the average annual runoff volume and a minimum removal of an annual average 60% of the sediment (TSS) load based on the Particle Size Distribution (PSD) specified in the sizing report for the specified device. Sizing of the OGS shall be determined by use of a minimum ten (10) years of local historical rainfall data provided by Environment Canada. Sizing shall also be determined by use of the sediment removal performance data derived from the ISO 14034 ETV third-party verified laboratory testing data from testing conducted in accordance with the Canadian ETV protocol Procedure for Laboratory Testing of Oil-Grit Separators, as follows:

3.2.1 Sediment removal efficiency for a given surface loading rate and its associated flow rate shall be based on sediment removal efficiency demonstrated at the seven (7) tested surface loading rates specified in the protocol, ranging 40 L/min/m² to 1400 L/min/m², and as stated in the ISO 14034 ETV Verification Statement for the OGS device.

3.2.2 Sediment removal efficiency for surface loading rates between 40 L/min/m² and 1400 L/min/m² shall be based on linear interpolation of data between consecutive tested surface loading rates.

3.2.3 Sediment removal efficiency for surface loading rates less than the lowest tested surface loading rate of 40 L/min/m² shall be assumed to be identical to the sediment removal efficiency at 40 L/min/m². No extrapolation shall be allowed that results in a sediment removal efficiency that is greater than that demonstrated at 40 L/min/m².

3.2.4 Sediment removal efficiency for surface loading rates greater than the highest tested surface loading rate of 1400 L/min/m² shall assume zero sediment removal for the portion of flow that exceeds 1400 L/min/m², and shall be calculated using a simple proportioning formula, with 1400 L/min/m² in the numerator and the higher surface loading rate in the denominator, and multiplying the resulting fraction times the sediment removal efficiency at 1400 L/min/m².

The OGS device shall also have sufficient annual sediment storage capacity as specified and calculated in Section 2.1.

3.3 CANADIAN ETV or ISO 14034 ETV VERIFICATION OF SCOUR TESTING

The OGS device shall have Canadian ETV or ISO 14034 ETV Verification of third-party scour testing conducted in accordance with the Canadian ETV Program's **Procedure for Laboratory Testing of Oil-Grit Separators**.

3.3.1 To be acceptable for on-line installation, the OGS device must demonstrate an average scour test effluent concentration less than 10 mg/L at each surface loading rate tested, up to and including 2600 L/min/m².

3.4 LIGHT LIQUID RE-ENTRAINMENT SIMULATION TESTING

The OGS device shall have Canadian ETV or ISO 14034 ETV Verification of completed third-party Light Liquid

Re-entrainment Simulation Testing in accordance with the Canadian ETV **Program's Procedure for Laboratory Testing of Oil-Grit Separators**, with results reported within the Canadian ETV or ISO 14034 ETV verification. This re-entrainment testing is conducted with the device pre-loaded with low density polyethylene (LDPE) plastic beads as a surrogate for light liquids such as oil and fuel. Testing is conducted on the same OGS unit tested for sediment removal to assess whether light liquids captured after a spill are effectively retained at high flow rates.

3.4.1 For an OGS device to be an acceptable stormwater treatment device on a site where vehicular traffic occurs and the potential for an oil or fuel spill exists, the OGS device must have reported verified performance results of greater than 99% cumulative retention of LDPE plastic beads for the five specified surface loading rates (ranging 200 L/min/m² to 2600 L/min/m²) in accordance with the Light Liquid Re-entrainment Simulation Testing within the Canadian ETV Program's **Procedure for Laboratory Testing of Oil-Grit Separators**. However, an OGS device shall not be allowed if the Light Liquid Re-entrainment Simulation Testing was performed with screening components within the OGS device that are effective at retaining the LDPE plastic beads, but would not be expected to retain light liquids such as oil and fuel.

Imbrium® Systems

ESTIMATED NET ANNUAL SEDIMENT (TSS) LOAD REDUCTION

12/11/2025

| | |
|---------------------------|----------------|
| Province: | Ontario |
| City: | Ottawa |
| Nearest Rainfall Station: | OTTAWA CDA RCS |
| Climate Station Id: | 6105978 |
| Years of Rainfall Data: | 20 |

| | |
|-------------------|-------------------------------|
| Project Name: | Othello |
| Project Number: | 69584 |
| Designer Name: | ROBBIE PICKARD |
| Designer Company: | EGIS |
| Designer Email: | robert.pickard@egis-group.com |
| Designer Phone: | 613-808-3427 |
| EOR Name: | |
| EOR Company: | |
| EOR Email: | |
| EOR Phone: | |

| | |
|------------|------|
| Site Name: | OGS2 |
|------------|------|

| | |
|---------------------|------|
| Drainage Area (ha): | 0.69 |
|---------------------|------|

| | |
|-------------------------|------|
| Runoff Coefficient 'c': | 0.84 |
|-------------------------|------|

| | |
|-----------------------------|------|
| Particle Size Distribution: | Fine |
|-----------------------------|------|

| | |
|-------------------------|------|
| Target TSS Removal (%): | 80.0 |
|-------------------------|------|

| | |
|--|--------|
| Required Water Quality Runoff Volume Capture (%): | 90.00 |
| Estimated Water Quality Flow Rate (L/s): | 18.71 |
| Oil / Fuel Spill Risk Site? | Yes |
| Upstream Flow Control? | Yes |
| Upstream Orifice Control Flow Rate to Stormceptor (L/s): | 35.57 |
| Peak Conveyance (maximum) Flow Rate (L/s): | 288.00 |
| Influent TSS Concentration (mg/L): | 200 |
| Estimated Average Annual Sediment Load (kg/yr): | 684 |
| Estimated Average Annual Sediment Volume (L/yr): | 556 |

| Net Annual Sediment (TSS) Load Reduction Sizing Summary | |
|---|--------------------------|
| Stormceptor Model | TSS Removal Provided (%) |
| EFO4 | 81 |
| EFO5 | 86 |
| EFO6 | 90 |
| EFO8 | 95 |
| EFO10 | 97 |
| EFO12 | 99 |

Recommended Stormceptor EFO Model: EFO4

Estimated Net Annual Sediment (TSS) Load Reduction (%): 81

Water Quality Runoff Volume Capture (%): > 90

THIRD-PARTY TESTING AND VERIFICATION

► **Stormceptor® EF and Stormceptor® EFO** are the latest evolutions in the Stormceptor® oil-grit separator (OGS) technology series, and are designed to remove a wide variety of pollutants from stormwater and snowmelt runoff. These technologies have been third-party tested in accordance with the Canadian ETV **Procedure for Laboratory Testing of Oil-Grit Separators** and performance has been third-party verified in accordance with the **ISO 14034 Environmental Technology Verification (ETV)** protocol.

PERFORMANCE

► **Stormceptor® EF and EFO** remove stormwater pollutants through gravity separation and floatation, and feature a patent-pending design that generates positive removal of total suspended solids (TSS) throughout each storm event, including high-intensity storms. Captured pollutants include sediment, free oils, and sediment-bound pollutants such as nutrients, heavy metals, and petroleum hydrocarbons. Stormceptor is sized to remove a high level of TSS from the frequent rainfall events that contribute the vast majority of annual runoff volume and pollutant load. The technology incorporates an internal bypass to convey excessive stormwater flows from high-intensity storms through the device without resuspension and washout (scour) of previously captured pollutants. Proper routine maintenance ensures high pollutant removal performance and protection of downstream waterways.

PARTICLE SIZE DISTRIBUTION (PSD)

► The **Canadian ETV PSD** shown in the table below was used, or in part, for this sizing. This is the identical PSD that is referenced in the Canadian ETV **Procedure for Laboratory Testing of Oil-Grit Separators** for both sediment removal testing and scour testing. The Canadian ETV PSD contains a wide range of particle sizes in the sand and silt fractions, and is considered reasonably representative of the particle size fractions found in typical urban stormwater runoff.

| Particle Size (µm) | Percent Less Than | Particle Size Fraction (µm) | Percent |
|--------------------|-------------------|-----------------------------|---------|
| 1000 | 100 | 500-1000 | 5 |
| 500 | 95 | 250-500 | 5 |
| 250 | 90 | 150-250 | 15 |
| 150 | 75 | 100-150 | 15 |
| 100 | 60 | 75-100 | 10 |
| 75 | 50 | 50-75 | 5 |
| 50 | 45 | 20-50 | 10 |
| 20 | 35 | 8-20 | 15 |
| 8 | 20 | 5-8 | 10 |
| 5 | 10 | 2-5 | 5 |
| 2 | 5 | <2 | 5 |

Upstream Flow Controlled Results

| Rainfall Intensity (mm / hr) | Percent Rainfall Volume (%) | Cumulative Rainfall Volume (%) | Flow Rate (L/s) | Flow Rate (L/min) | Surface Loading Rate (L/min/m ²) | Removal Efficiency (%) | Incremental Removal (%) | Cumulative Removal (%) |
|---|-----------------------------|--------------------------------|-----------------|-------------------|--|------------------------|-------------------------|------------------------|
| 0.50 | 8.6 | 8.6 | 0.81 | 48.0 | 40.0 | 100 | 8.6 | 8.6 |
| 1.00 | 20.3 | 29.0 | 1.61 | 97.0 | 81.0 | 98 | 20.0 | 28.6 |
| 2.00 | 16.2 | 45.2 | 3.22 | 193.0 | 161.0 | 88 | 14.3 | 43.0 |
| 3.00 | 12.0 | 57.2 | 4.83 | 290.0 | 242.0 | 81 | 9.7 | 52.7 |
| 4.00 | 8.4 | 65.6 | 6.45 | 387.0 | 322.0 | 78 | 6.5 | 59.2 |
| 5.00 | 5.9 | 71.6 | 8.06 | 483.0 | 403.0 | 74 | 4.4 | 63.6 |
| 6.00 | 4.6 | 76.2 | 9.67 | 580.0 | 483.0 | 70 | 3.3 | 66.9 |
| 7.00 | 3.1 | 79.3 | 11.28 | 677.0 | 564.0 | 66 | 2.0 | 68.9 |
| 8.00 | 2.7 | 82.0 | 12.89 | 773.0 | 645.0 | 64 | 1.8 | 70.7 |
| 9.00 | 3.3 | 85.3 | 14.50 | 870.0 | 725.0 | 64 | 2.1 | 72.8 |
| 10.00 | 2.3 | 87.6 | 16.11 | 967.0 | 806.0 | 63 | 1.4 | 74.3 |
| 11.00 | 1.6 | 89.2 | 17.72 | 1063.0 | 886.0 | 62 | 1.0 | 75.2 |
| 12.00 | 1.3 | 90.5 | 19.34 | 1160.0 | 967.0 | 62 | 0.8 | 76.0 |
| 13.00 | 1.7 | 92.2 | 20.95 | 1257.0 | 1047.0 | 61 | 1.0 | 77.1 |
| 14.00 | 1.2 | 93.5 | 22.56 | 1353.0 | 1128.0 | 59 | 0.7 | 77.8 |
| 15.00 | 1.2 | 94.6 | 24.17 | 1450.0 | 1208.0 | 57 | 0.7 | 78.5 |
| 16.00 | 0.7 | 95.3 | 25.78 | 1547.0 | 1289.0 | 55 | 0.4 | 78.9 |
| 17.00 | 0.7 | 96.1 | 27.39 | 1644.0 | 1370.0 | 53 | 0.4 | 79.2 |
| 18.00 | 0.4 | 96.5 | 29.00 | 1740.0 | 1450.0 | 51 | 0.2 | 79.4 |
| 19.00 | 0.4 | 96.9 | 30.61 | 1837.0 | 1531.0 | 48 | 0.2 | 79.6 |
| 20.00 | 0.2 | 97.1 | 32.23 | 1934.0 | 1611.0 | 45 | 0.1 | 79.7 |
| 21.00 | 0.5 | 97.5 | 33.84 | 2030.0 | 1692.0 | 43 | 0.2 | 79.9 |
| 22.00 | 2.5 | 100.0 | 35.45 | 2127.0 | 1772.0 | 41 | 1.0 | 81.0 |
| 23.00 | 0.0 | 100.0 | 36.00 | 2160.0 | 1800.0 | 41 | 0.0 | 81.0 |
| 24.00 | 0.0 | 100.0 | 36.00 | 2160.0 | 1800.0 | 41 | 0.0 | 81.0 |
| 25.00 | 0.0 | 100.0 | 36.00 | 2160.0 | 1800.0 | 41 | 0.0 | 81.0 |
| 30.00 | 0.0 | 100.0 | 36.00 | 2160.0 | 1800.0 | 41 | 0.0 | 81.0 |
| 35.00 | 0.0 | 100.0 | 36.00 | 2160.0 | 1800.0 | 41 | 0.0 | 81.0 |
| 40.00 | 0.0 | 100.0 | 36.00 | 2160.0 | 1800.0 | 41 | 0.0 | 81.0 |
| 45.00 | 0.0 | 100.0 | 36.00 | 2160.0 | 1800.0 | 41 | 0.0 | 81.0 |
| Estimated Net Annual Sediment (TSS) Load Reduction = | | | | | | | | 81 % |

Climate Station ID: 6105978 Years of Rainfall Data: 20

RAINFALL DATA FROM OTTAWA CDA RCS RAINFALL STATION

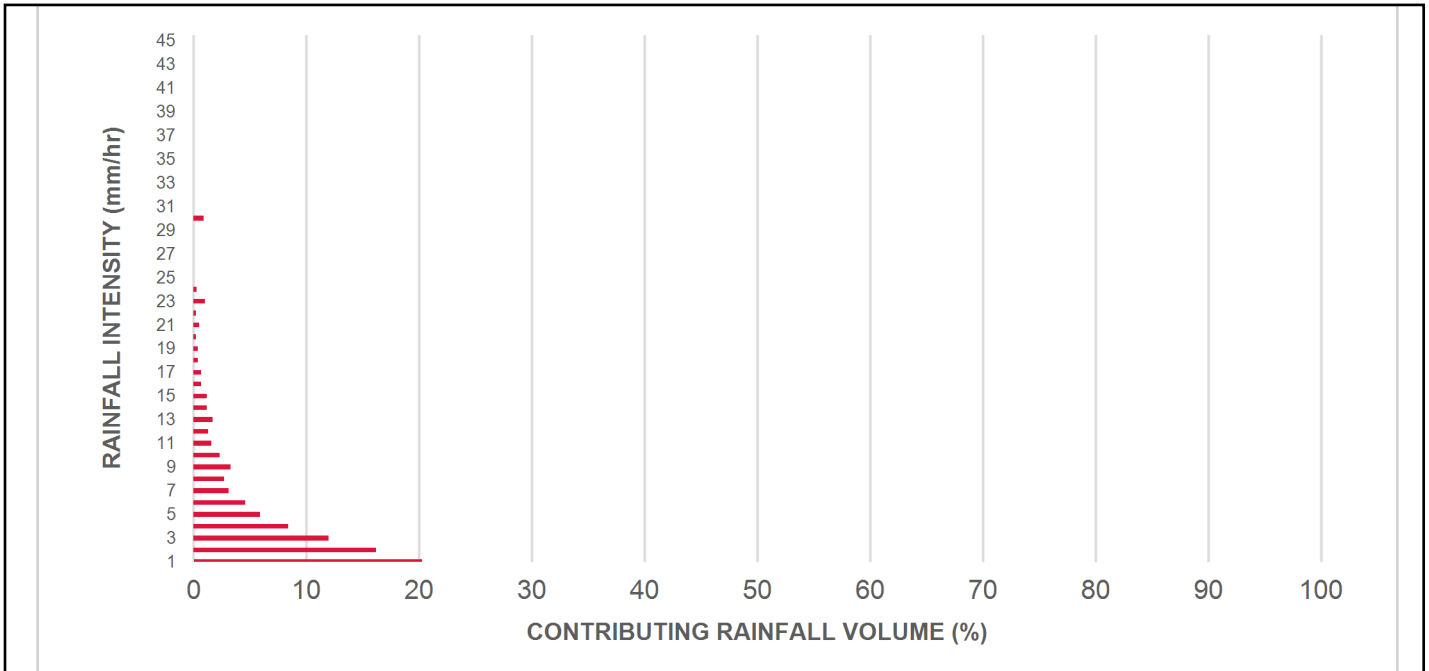

INCREMENTAL AND CUMULATIVE TSS REMOVAL FOR THE RECOMMENDED STORMCEPTOR[®] MODEL

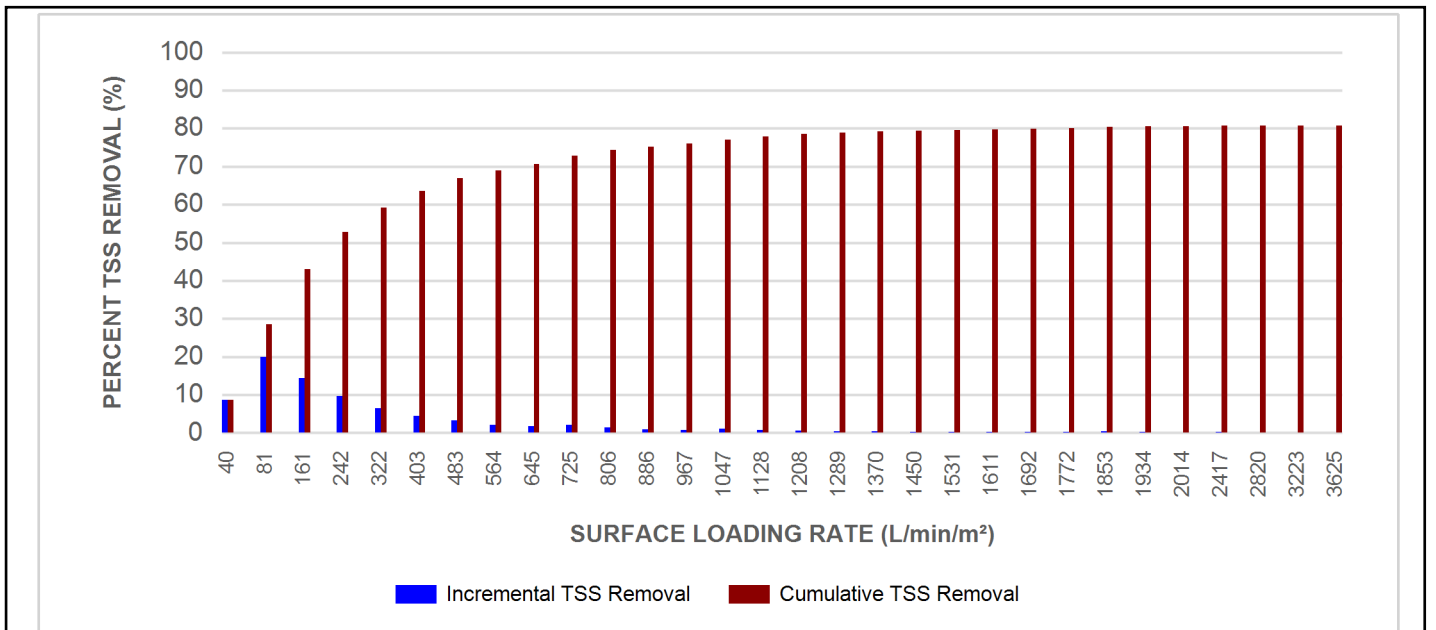

Maximum Pipe Diameter / Peak Conveyance

| Stormceptor EF / EFO | Model Diameter | | Min Angle Inlet / Outlet Pipes | Max Inlet Pipe Diameter | | Max Outlet Pipe Diameter | | Peak Conveyance Flow Rate | |
|-------------------------|----------------|------|-----------------------------------|----------------------------|------|-----------------------------|------|------------------------------|-------|
| | (m) | (ft) | | (mm) | (in) | (mm) | (in) | (L/s) | (cfs) |
| EF4 / EFO4 | 1.2 | 4 | 90 | 609 | 24 | 609 | 24 | 425 | 15 |
| EF5 / EFO5 | 1.5 | 5 | 90 | 762 | 30 | 762 | 30 | 710 | 25 |
| EF6 / EFO6 | 1.8 | 6 | 90 | 914 | 36 | 914 | 36 | 990 | 35 |
| EF8 / EFO8 | 2.4 | 8 | 90 | 1219 | 48 | 1219 | 48 | 1700 | 60 |
| EF10 / EFO10 | 3.0 | 10 | 90 | 1828 | 72 | 1828 | 72 | 2830 | 100 |
| EF12 / EFO12 | 3.6 | 12 | 90 | 1828 | 72 | 1828 | 72 | 2830 | 100 |

SCOUR PREVENTION AND ONLINE CONFIGURATION

► Stormceptor® EF and EFO feature an internal bypass and superior scour prevention technology that have been demonstrated in third-party testing according to the scour testing provisions of the Canadian ETV **Procedure for Laboratory Testing of Oil-Grit Separators**, and the exceptional scour test performance has been third-party verified in accordance with the ISO 14034 ETV protocol. As a result, Stormceptor EF and EFO are approved for online installation, eliminating the need for costly additional bypass structures, piping, and installation expense.

DESIGN FLEXIBILITY

► Stormceptor® EF and EFO offers design flexibility in one simplified platform, accepting stormwater flow from a single inlet pipe or multiple inlet pipes, and/or surface runoff through an inlet grate. The device can also serve as a junction structure, accommodate a 90-degree inlet-to-outlet bend angle, and can be modified to ensure performance in submerged conditions.

OIL CAPTURE AND RETENTION

► While Stormceptor® EF will capture and retain oil from dry weather spills and low intensity runoff, Stormceptor® EFO has demonstrated superior oil capture and greater than 99% oil retention in third-party testing according to the light liquid re-entrainment testing provisions of the Canadian ETV **Procedure for Laboratory Testing of Oil-Grit Separators**. Stormceptor EFO is recommended for sites where oil capture and retention is a requirement.

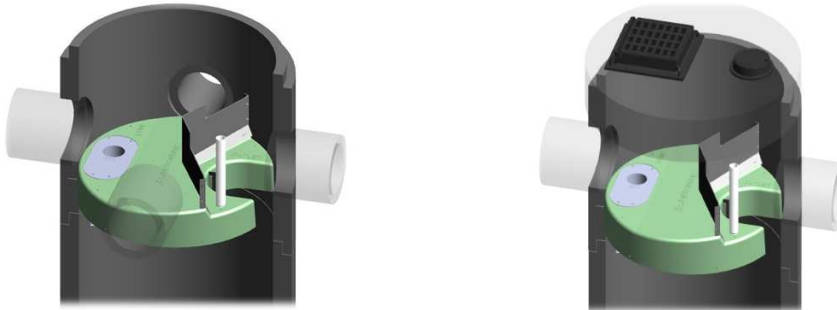

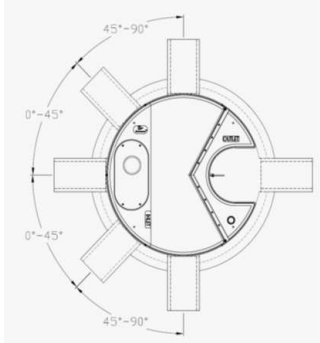

INLET-TO-OUTLET DROP

Elevation differential between inlet and outlet pipe inverts is dictated by the angle at which the inlet pipe(s) enters the unit.

0° - 45° : The inlet pipe is 1-inch (25mm) higher than the outlet pipe.

45° - 90° : The inlet pipe is 2-inches (50mm) higher than the outlet pipe.

HEAD LOSS

The head loss through Stormceptor EF is similar to that of a 60-degree bend structure. The applicable K value for calculating minor losses through the unit is 1.1. For submerged conditions the applicable K value is 3.0.

Pollutant Capacity

| Stormceptor EF / EFO | Model Diameter | | Depth (Outlet Pipe Invert to Sump Floor) | | Oil Volume | | Recommended Sediment Maintenance Depth * | | Maximum Sediment Volume * | | Maximum Sediment Mass ** | |
|----------------------|----------------|------|--|------|------------|-------|--|------|---------------------------|--------------------|--------------------------|--------|
| | (m) | (ft) | (m) | (ft) | (L) | (Gal) | (mm) | (in) | (L) | (ft ³) | (kg) | (lb) |
| EF4 / EFO4 | 1.2 | 4 | 1.52 | 5.0 | 265 | 70 | 203 | 8 | 1190 | 42 | 1904 | 5250 |
| EF5 / EFO5 | 1.5 | 5 | 1.62 | 5.3 | 420 | 111 | 305 | 10 | 2124 | 75 | 2612 | 5758 |
| EF6 / EFO6 | 1.8 | 6 | 1.93 | 6.3 | 610 | 160 | 305 | 12 | 3470 | 123 | 5552 | 15375 |
| EF8 / EFO8 | 2.4 | 8 | 2.59 | 8.5 | 1070 | 280 | 610 | 24 | 8780 | 310 | 14048 | 38750 |
| EF10 / EFO10 | 3.0 | 10 | 3.25 | 10.7 | 1670 | 440 | 610 | 24 | 17790 | 628 | 28464 | 78500 |
| EF12 / EFO12 | 3.6 | 12 | 3.89 | 12.8 | 2475 | 655 | 610 | 24 | 31220 | 1103 | 49952 | 137875 |

*Increased sump depth may be added to increase sediment storage capacity

** Average density of wet packed sediment in sump = 1.6 kg/L (100 lb/ft³)

| Feature | Benefit | Feature Appeals To |
|---|---|---|
| Patent-pending enhanced flow treatment and scour prevention technology | Superior, verified third-party performance | Regulator, Specifying & Design Engineer |
| Third-party verified light liquid capture and retention for EFO version | Proven performance for fuel/oil hotspot locations | Regulator, Specifying & Design Engineer, Site Owner |
| Functions as bend, junction or inlet structure | Design flexibility | Specifying & Design Engineer |
| Minimal drop between inlet and outlet | Site installation ease | Contractor |
| Large diameter outlet riser for inspection and maintenance | Easy maintenance access from grade | Maintenance Contractor & Site Owner |

STANDARD STORMCEPTOR EF/EFO DRAWINGS

For standard details, please visit <http://www.imbriumsystems.com/stormwater-treatment-solutions/stormceptor-ef>

STANDARD STORMCEPTOR EF/EFO SPECIFICATION

For specifications, please visit <http://www.imbriumsystems.com/stormwater-treatment-solutions/stormceptor-ef>

STANDARD PERFORMANCE SPECIFICATION FOR “OIL GRIT SEPARATOR” (OGS) STORMWATER QUALITY TREATMENT DEVICE

PART 1 – GENERAL

1.1 WORK INCLUDED

This section specifies requirements for selecting, sizing, and designing an underground Oil Grit Separator (OGS) device for stormwater quality treatment, with third-party testing results and a Statement of Verification in accordance with ISO 14034 Environmental Management – Environmental Technology Verification (ETV).

1.2 REFERENCE STANDARDS & PROCEDURES

ISO 14034:2016 Environmental management – Environmental technology verification (ETV)

Canadian Environmental Technology Verification (ETV) Program’s **Procedure for Laboratory Testing of Oil-Grit Separators**

1.3 SUBMITTALS

1.3.1 All submittals, including sizing reports & shop drawings, shall be submitted upon request with each order to the contractor then forwarded to the Engineer of Record for review and acceptance. Shop drawings shall detail all OGS components, elevations, and sequence of construction.

1.3.2 Alternative devices shall have features identical to or greater than the specified device, including: treatment chamber diameter, treatment chamber wet volume, sediment storage volume, and oil storage volume.

1.3.3 Unless directed otherwise by the Engineer of Record, OGS stormwater quality treatment product substitutions or alternatives submitted within ten days prior to project bid shall not be accepted. All alternatives or substitutions submitted shall be signed and sealed by a local registered Professional Engineer, based on the exact same criteria detailed in Section 3, in entirety, subject to review and approval by the Engineer of Record.

PART 2 – PRODUCTS

2.1 OGS POLLUTANT STORAGE

The OGS device shall include a sump for sediment storage, and a protected volume for the capture and storage of petroleum hydrocarbons and buoyant gross pollutants. The minimum sediment & petroleum hydrocarbon storage capacity shall be as follows:

| | | |
|-------|-------------------------------------|---|
| 2.1.1 | 4 ft (1219 mm) Diameter OGS Units: | 1.19 m ³ sediment / 265 L oil |
| | 5 ft (1524 mm) Diameter OGS Units: | 1.95 m ³ sediment / 420 L oil |
| | 6 ft (1829 mm) Diameter OGS Units: | 3.48 m ³ sediment / 609 L oil |
| | 8 ft (2438 mm) Diameter OGS Units: | 8.78 m ³ sediment / 1,071 L oil |
| | 10 ft (3048 mm) Diameter OGS Units: | 17.78 m ³ sediment / 1,673 L oil |
| | 12 ft (3657 mm) Diameter OGS Units: | 31.23 m ³ sediment / 2,476 L oil |

PART 3 – PERFORMANCE & DESIGN

3.1 GENERAL

The OGS stormwater quality treatment device shall be verified in accordance with ISO 14034:2016 Environmental management – Environmental technology verification (ETV). The OGS stormwater quality treatment device shall remove oil, sediment and gross pollutants from stormwater runoff during frequent wet weather events, and retain these pollutants during less frequent high flow wet weather events below the insert within the OGS for later removal during maintenance. The Manufacturer shall have at least ten (10) years of local experience, history and success in engineering design, manufacturing and production and supply of OGS stormwater quality treatment device systems, acceptable to the Engineer of Record.

3.2 SIZING METHODOLOGY

The OGS device shall be engineered, designed and sized to provide stormwater quality treatment based on treating a minimum of 90 percent of the average annual runoff volume and a minimum removal of an annual average 60% of the sediment (TSS) load based on the Particle Size Distribution (PSD) specified in the sizing report for the specified device. Sizing of the OGS shall be determined by use of a minimum ten (10) years of local historical rainfall data provided by Environment Canada. Sizing shall also be determined by use of the sediment removal performance data derived from the ISO 14034 ETV third-party verified laboratory testing data from testing conducted in accordance with the Canadian ETV protocol Procedure for Laboratory Testing of Oil-Grit Separators, as follows:

3.2.1 Sediment removal efficiency for a given surface loading rate and its associated flow rate shall be based on sediment removal efficiency demonstrated at the seven (7) tested surface loading rates specified in the protocol, ranging 40 L/min/m² to 1400 L/min/m², and as stated in the ISO 14034 ETV Verification Statement for the OGS device.

3.2.2 Sediment removal efficiency for surface loading rates between 40 L/min/m² and 1400 L/min/m² shall be based on linear interpolation of data between consecutive tested surface loading rates.

3.2.3 Sediment removal efficiency for surface loading rates less than the lowest tested surface loading rate of 40 L/min/m² shall be assumed to be identical to the sediment removal efficiency at 40 L/min/m². No extrapolation shall be allowed that results in a sediment removal efficiency that is greater than that demonstrated at 40 L/min/m².

3.2.4 Sediment removal efficiency for surface loading rates greater than the highest tested surface loading rate of 1400 L/min/m² shall assume zero sediment removal for the portion of flow that exceeds 1400 L/min/m², and shall be calculated using a simple proportioning formula, with 1400 L/min/m² in the numerator and the higher surface loading rate in the denominator, and multiplying the resulting fraction times the sediment removal efficiency at 1400 L/min/m².

The OGS device shall also have sufficient annual sediment storage capacity as specified and calculated in Section 2.1.

3.3 CANADIAN ETV or ISO 14034 ETV VERIFICATION OF SCOUR TESTING

The OGS device shall have Canadian ETV or ISO 14034 ETV Verification of third-party scour testing conducted in accordance with the Canadian ETV Program's **Procedure for Laboratory Testing of Oil-Grit Separators**.

3.3.1 To be acceptable for on-line installation, the OGS device must demonstrate an average scour test effluent concentration less than 10 mg/L at each surface loading rate tested, up to and including 2600 L/min/m².

3.4 LIGHT LIQUID RE-ENTRAINMENT SIMULATION TESTING

The OGS device shall have Canadian ETV or ISO 14034 ETV Verification of completed third-party Light Liquid

Re-entrainment Simulation Testing in accordance with the Canadian ETV **Program's Procedure for Laboratory Testing of Oil-Grit Separators**, with results reported within the Canadian ETV or ISO 14034 ETV verification. This re-entrainment testing is conducted with the device pre-loaded with low density polyethylene (LDPE) plastic beads as a surrogate for light liquids such as oil and fuel. Testing is conducted on the same OGS unit tested for sediment removal to assess whether light liquids captured after a spill are effectively retained at high flow rates.

3.4.1 For an OGS device to be an acceptable stormwater treatment device on a site where vehicular traffic occurs and the potential for an oil or fuel spill exists, the OGS device must have reported verified performance results of greater than 99% cumulative retention of LDPE plastic beads for the five specified surface loading rates (ranging 200 L/min/m² to 2600 L/min/m²) in accordance with the Light Liquid Re-entrainment Simulation Testing within the Canadian ETV Program's **Procedure for Laboratory Testing of Oil-Grit Separators**. However, an OGS device shall not be allowed if the Light Liquid Re-entrainment Simulation Testing was performed with screening components within the OGS device that are effective at retaining the LDPE plastic beads, but would not be expected to retain light liquids such as oil and fuel.

Imbrium® Systems
ESTIMATED NET ANNUAL SEDIMENT (TSS) LOAD REDUCTION

12/11/2025

| | |
|---------------------------|----------------|
| Province: | Ontario |
| City: | Ottawa |
| Nearest Rainfall Station: | OTTAWA CDA RCS |
| Climate Station Id: | 6105978 |
| Years of Rainfall Data: | 20 |

| | |
|-------------------|-------------------------------|
| Project Name: | Othello |
| Project Number: | 69584 |
| Designer Name: | ROBBIE PICKARD |
| Designer Company: | EGIS |
| Designer Email: | robert.pickard@egis-group.com |
| Designer Phone: | 613-808-3427 |
| EOR Name: | |
| EOR Company: | |
| EOR Email: | |
| EOR Phone: | |

| | |
|-------------------------|------|
| Site Name: | OGS3 |
| Drainage Area (ha): | 0.60 |
| Runoff Coefficient 'c': | 0.85 |

| | |
|-----------------------------|------|
| Particle Size Distribution: | Fine |
| Target TSS Removal (%): | 80.0 |

| | |
|--|--------|
| Required Water Quality Runoff Volume Capture (%): | 90.00 |
| Estimated Water Quality Flow Rate (L/s): | 16.46 |
| Oil / Fuel Spill Risk Site? | Yes |
| Upstream Flow Control? | Yes |
| Upstream Orifice Control Flow Rate to Stormceptor (L/s): | 127.16 |
| Peak Conveyance (maximum) Flow Rate (L/s): | 252.45 |
| Influent TSS Concentration (mg/L): | 200 |
| Estimated Average Annual Sediment Load (kg/yr): | 621 |
| Estimated Average Annual Sediment Volume (L/yr): | 505 |

| Net Annual Sediment (TSS) Load Reduction Sizing Summary | |
|---|--------------------------|
| Stormceptor Model | TSS Removal Provided (%) |
| EFO4 | 83 |
| EFO5 | 88 |
| EFO6 | 92 |
| EFO8 | 96 |
| EFO10 | 98 |
| EFO12 | 99 |

Recommended Stormceptor EFO Model: EFO4
Estimated Net Annual Sediment (TSS) Load Reduction (%): 83
Water Quality Runoff Volume Capture (%): > 90



THIRD-PARTY TESTING AND VERIFICATION

► **Stormceptor® EF and Stormceptor® EFO** are the latest evolutions in the Stormceptor® oil-grit separator (OGS) technology series, and are designed to remove a wide variety of pollutants from stormwater and snowmelt runoff. These technologies have been third-party tested in accordance with the Canadian ETV **Procedure for Laboratory Testing of Oil-Grit Separators** and performance has been third-party verified in accordance with the **ISO 14034 Environmental Technology Verification (ETV)** protocol.

PERFORMANCE

► **Stormceptor® EF and EFO** remove stormwater pollutants through gravity separation and floatation, and feature a patent-pending design that generates positive removal of total suspended solids (TSS) throughout each storm event, including high-intensity storms. Captured pollutants include sediment, free oils, and sediment-bound pollutants such as nutrients, heavy metals, and petroleum hydrocarbons. Stormceptor is sized to remove a high level of TSS from the frequent rainfall events that contribute the vast majority of annual runoff volume and pollutant load. The technology incorporates an internal bypass to convey excessive stormwater flows from high-intensity storms through the device without resuspension and washout (scour) of previously captured pollutants. Proper routine maintenance ensures high pollutant removal performance and protection of downstream waterways.

PARTICLE SIZE DISTRIBUTION (PSD)

► The **Canadian ETV PSD** shown in the table below was used, or in part, for this sizing. This is the identical PSD that is referenced in the Canadian ETV **Procedure for Laboratory Testing of Oil-Grit Separators** for both sediment removal testing and scour testing. The Canadian ETV PSD contains a wide range of particle sizes in the sand and silt fractions, and is considered reasonably representative of the particle size fractions found in typical urban stormwater runoff.

| Particle Size (µm) | Percent Less Than | Particle Size Fraction (µm) | Percent |
|--------------------|-------------------|-----------------------------|---------|
| 1000 | 100 | 500-1000 | 5 |
| 500 | 95 | 250-500 | 5 |
| 250 | 90 | 150-250 | 15 |
| 150 | 75 | 100-150 | 15 |
| 100 | 60 | 75-100 | 10 |
| 75 | 50 | 50-75 | 5 |
| 50 | 45 | 20-50 | 10 |
| 20 | 35 | 8-20 | 15 |
| 8 | 20 | 5-8 | 10 |
| 5 | 10 | 2-5 | 5 |
| 2 | 5 | <2 | 5 |

Upstream Flow Controlled Results

| Rainfall Intensity (mm / hr) | Percent Rainfall Volume (%) | Cumulative Rainfall Volume (%) | Flow Rate (L/s) | Flow Rate (L/min) | Surface Loading Rate (L/min/m ²) | Removal Efficiency (%) | Incremental Removal (%) | Cumulative Removal (%) |
|---|-----------------------------|--------------------------------|-----------------|-------------------|--|------------------------|-------------------------|------------------------|
| 0.50 | 8.6 | 8.6 | 0.71 | 43.0 | 35.0 | 100 | 8.6 | 8.6 |
| 1.00 | 20.3 | 29.0 | 1.42 | 85.0 | 71.0 | 100 | 20.3 | 29.0 |
| 2.00 | 16.2 | 45.2 | 2.84 | 170.0 | 142.0 | 91 | 14.7 | 43.7 |
| 3.00 | 12.0 | 57.2 | 4.25 | 255.0 | 213.0 | 83 | 9.9 | 53.6 |
| 4.00 | 8.4 | 65.6 | 5.67 | 340.0 | 284.0 | 79 | 6.7 | 60.3 |
| 5.00 | 5.9 | 71.6 | 7.09 | 425.0 | 354.0 | 76 | 4.5 | 64.8 |
| 6.00 | 4.6 | 76.2 | 8.51 | 510.0 | 425.0 | 73 | 3.4 | 68.2 |
| 7.00 | 3.1 | 79.3 | 9.92 | 595.0 | 496.0 | 70 | 2.1 | 70.3 |
| 8.00 | 2.7 | 82.0 | 11.34 | 681.0 | 567.0 | 66 | 1.8 | 72.2 |
| 9.00 | 3.3 | 85.3 | 12.76 | 766.0 | 638.0 | 64 | 2.1 | 74.3 |
| 10.00 | 2.3 | 87.6 | 14.18 | 851.0 | 709.0 | 64 | 1.5 | 75.8 |
| 11.00 | 1.6 | 89.2 | 15.60 | 936.0 | 780.0 | 63 | 1.0 | 76.8 |
| 12.00 | 1.3 | 90.5 | 17.01 | 1021.0 | 851.0 | 63 | 0.8 | 77.6 |
| 13.00 | 1.7 | 92.2 | 18.43 | 1106.0 | 922.0 | 62 | 1.1 | 78.7 |
| 14.00 | 1.2 | 93.5 | 19.85 | 1191.0 | 992.0 | 62 | 0.8 | 79.4 |
| 15.00 | 1.2 | 94.6 | 21.27 | 1276.0 | 1063.0 | 60 | 0.7 | 80.1 |
| 16.00 | 0.7 | 95.3 | 22.68 | 1361.0 | 1134.0 | 59 | 0.4 | 80.5 |
| 17.00 | 0.7 | 96.1 | 24.10 | 1446.0 | 1205.0 | 57 | 0.4 | 80.9 |
| 18.00 | 0.4 | 96.5 | 25.52 | 1531.0 | 1276.0 | 55 | 0.2 | 81.2 |
| 19.00 | 0.4 | 96.9 | 26.94 | 1616.0 | 1347.0 | 54 | 0.2 | 81.4 |
| 20.00 | 0.2 | 97.1 | 28.36 | 1701.0 | 1418.0 | 52 | 0.1 | 81.5 |
| 21.00 | 0.5 | 97.5 | 29.77 | 1786.0 | 1489.0 | 49 | 0.2 | 81.7 |
| 22.00 | 0.2 | 97.8 | 31.19 | 1871.0 | 1560.0 | 47 | 0.1 | 81.8 |
| 23.00 | 1.0 | 98.8 | 32.61 | 1957.0 | 1630.0 | 45 | 0.5 | 82.3 |
| 24.00 | 0.3 | 99.1 | 34.03 | 2042.0 | 1701.0 | 43 | 0.1 | 82.4 |
| 25.00 | 0.9 | 100.0 | 35.45 | 2127.0 | 1772.0 | 41 | 0.4 | 82.8 |
| 30.00 | 0.9 | 100.9 | 42.53 | 2552.0 | 2127.0 | 35 | 0.3 | 83.1 |
| 35.00 | -0.9 | 100.0 | 49.62 | 2977.0 | 2481.0 | 30 | N/A | 82.8 |
| 40.00 | 0.0 | 100.0 | 56.71 | 3403.0 | 2836.0 | 26 | 0.0 | 82.8 |
| 45.00 | 0.0 | 100.0 | 63.80 | 3828.0 | 3190.0 | 24 | 0.0 | 82.8 |
| Estimated Net Annual Sediment (TSS) Load Reduction = | | | | | | | | 83 % |

Climate Station ID: 6105978 Years of Rainfall Data: 20

RAINFALL DATA FROM OTTAWA CDA RCS RAINFALL STATION

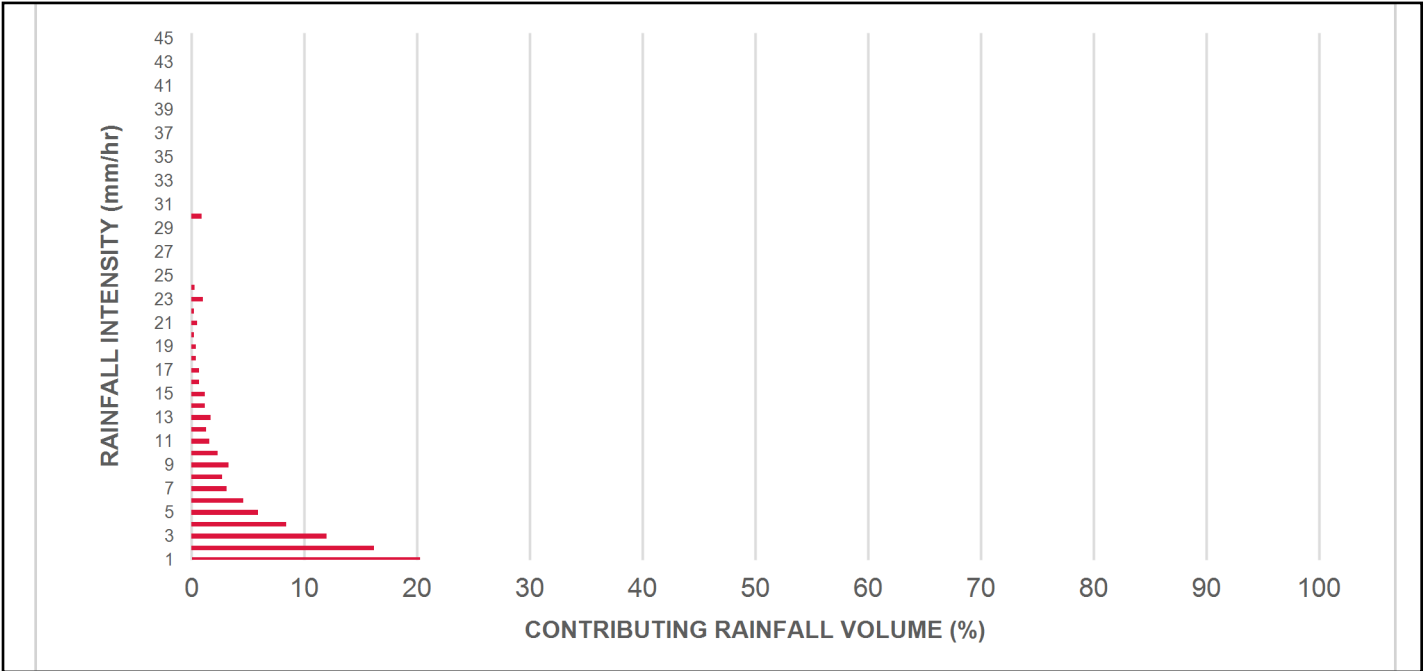

INCREMENTAL AND CUMULATIVE TSS REMOVAL FOR THE RECOMMENDED STORMCEPTOR[®] MODEL

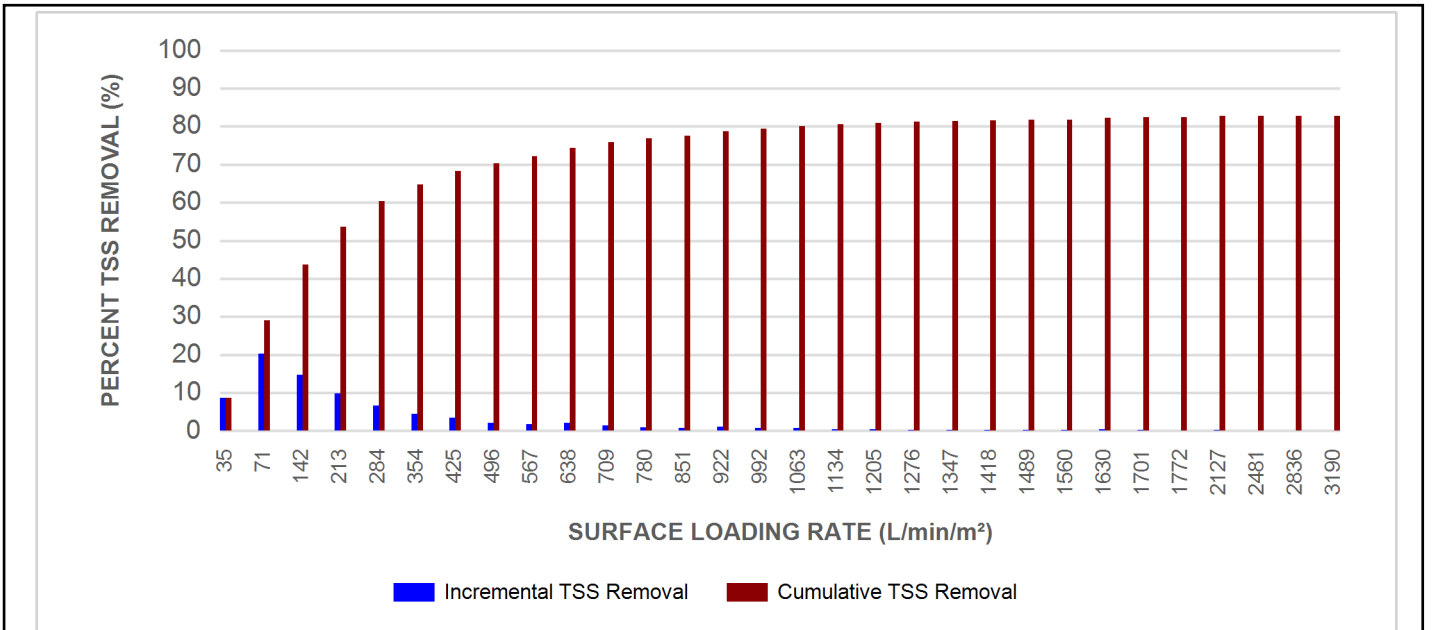

Maximum Pipe Diameter / Peak Conveyance

| Stormceptor EF / EFO | Model Diameter | | Min Angle Inlet / Outlet Pipes | Max Inlet Pipe Diameter | | Max Outlet Pipe Diameter | | Peak Conveyance Flow Rate | |
|-------------------------|----------------|------|-----------------------------------|----------------------------|------|-----------------------------|------|------------------------------|-------|
| | (m) | (ft) | | (mm) | (in) | (mm) | (in) | (L/s) | (cfs) |
| EF4 / EFO4 | 1.2 | 4 | 90 | 609 | 24 | 609 | 24 | 425 | 15 |
| EF5 / EFO5 | 1.5 | 5 | 90 | 762 | 30 | 762 | 30 | 710 | 25 |
| EF6 / EFO6 | 1.8 | 6 | 90 | 914 | 36 | 914 | 36 | 990 | 35 |
| EF8 / EFO8 | 2.4 | 8 | 90 | 1219 | 48 | 1219 | 48 | 1700 | 60 |
| EF10 / EFO10 | 3.0 | 10 | 90 | 1828 | 72 | 1828 | 72 | 2830 | 100 |
| EF12 / EFO12 | 3.6 | 12 | 90 | 1828 | 72 | 1828 | 72 | 2830 | 100 |

SCOUR PREVENTION AND ONLINE CONFIGURATION

► **Stormceptor® EF and EFO** feature an internal bypass and superior scour prevention technology that have been demonstrated in third-party testing according to the scour testing provisions of the Canadian ETV **Procedure for Laboratory Testing of Oil-Grit Separators**, and the exceptional scour test performance has been third-party verified in accordance with the ISO 14034 ETV protocol. As a result, Stormceptor EF and EFO are approved for online installation, eliminating the need for costly additional bypass structures, piping, and installation expense.

DESIGN FLEXIBILITY

► **Stormceptor® EF and EFO** offers design flexibility in one simplified platform, accepting stormwater flow from a single inlet pipe or multiple inlet pipes, and/or surface runoff through an inlet grate. The device can also serve as a junction structure, accommodate a 90-degree inlet-to-outlet bend angle, and can be modified to ensure performance in submerged conditions.

OIL CAPTURE AND RETENTION

► While Stormceptor® EF will capture and retain oil from dry weather spills and low intensity runoff, **Stormceptor® EFO** has demonstrated superior oil capture and greater than 99% oil retention in third-party testing according to the light liquid re-entrainment testing provisions of the Canadian ETV **Procedure for Laboratory Testing of Oil-Grit Separators**. Stormceptor EFO is recommended for sites where oil capture and retention is a requirement.



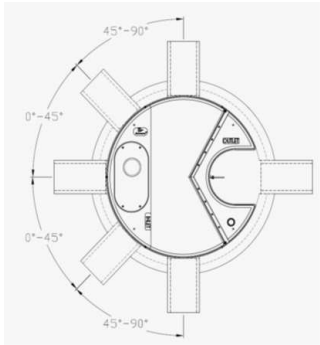

INLET-TO-OUTLET DROP

Elevation differential between inlet and outlet pipe inverts is dictated by the angle at which the inlet pipe(s) enters the unit.

0° - 45° : The inlet pipe is 1-inch (25mm) higher than the outlet pipe.

45° - 90° : The inlet pipe is 2-inches (50mm) higher than the outlet pipe.

HEAD LOSS

The head loss through Stormceptor EF is similar to that of a 60-degree bend structure. The applicable K value for calculating minor losses through the unit is 1.1. For submerged conditions the applicable K value is 3.0.

Pollutant Capacity

| Stormceptor EF / EFO | Model Diameter | | Depth (Outlet Pipe Invert to Sump Floor) | | Oil Volume | | Recommended Sediment Maintenance Depth * | | Maximum Sediment Volume * | | Maximum Sediment Mass ** | |
|----------------------|----------------|------|--|------|------------|-------|--|------|---------------------------|--------------------|--------------------------|--------|
| | (m) | (ft) | (m) | (ft) | (L) | (Gal) | (mm) | (in) | (L) | (ft ³) | (kg) | (lb) |
| EF4 / EFO4 | 1.2 | 4 | 1.52 | 5.0 | 265 | 70 | 203 | 8 | 1190 | 42 | 1904 | 5250 |
| EF5 / EFO5 | 1.5 | 5 | 1.62 | 5.3 | 420 | 111 | 305 | 10 | 2124 | 75 | 2612 | 5758 |
| EF6 / EFO6 | 1.8 | 6 | 1.93 | 6.3 | 610 | 160 | 305 | 12 | 3470 | 123 | 5552 | 15375 |
| EF8 / EFO8 | 2.4 | 8 | 2.59 | 8.5 | 1070 | 280 | 610 | 24 | 8780 | 310 | 14048 | 38750 |
| EF10 / EFO10 | 3.0 | 10 | 3.25 | 10.7 | 1670 | 440 | 610 | 24 | 17790 | 628 | 28464 | 78500 |
| EF12 / EFO12 | 3.6 | 12 | 3.89 | 12.8 | 2475 | 655 | 610 | 24 | 31220 | 1103 | 49952 | 137875 |

*Increased sump depth may be added to increase sediment storage capacity

** Average density of wet packed sediment in sump = 1.6 kg/L (100 lb/ft³)

| Feature | Benefit | Feature Appeals To |
|---|---|---|
| Patent-pending enhanced flow treatment and scour prevention technology | Superior, verified third-party performance | Regulator, Specifying & Design Engineer |
| Third-party verified light liquid capture and retention for EFO version | Proven performance for fuel/oil hotspot locations | Regulator, Specifying & Design Engineer, Site Owner |
| Functions as bend, junction or inlet structure | Design flexibility | Specifying & Design Engineer |
| Minimal drop between inlet and outlet | Site installation ease | Contractor |
| Large diameter outlet riser for inspection and maintenance | Easy maintenance access from grade | Maintenance Contractor & Site Owner |

STANDARD STORMCEPTOR EF/EFO DRAWINGS

For standard details, please visit <http://www.imbriumsystems.com/stormwater-treatment-solutions/stormceptor-ef>

STANDARD STORMCEPTOR EF/EFO SPECIFICATION

For specifications, please visit <http://www.imbriumsystems.com/stormwater-treatment-solutions/stormceptor-ef>

STANDARD PERFORMANCE SPECIFICATION FOR “OIL GRIT SEPARATOR” (OGS) STORMWATER QUALITY TREATMENT DEVICE

PART 1 – GENERAL

1.1 WORK INCLUDED

This section specifies requirements for selecting, sizing, and designing an underground Oil Grit Separator (OGS) device for stormwater quality treatment, with third-party testing results and a Statement of Verification in accordance with ISO 14034 Environmental Management – Environmental Technology Verification (ETV).

1.2 REFERENCE STANDARDS & PROCEDURES

ISO 14034:2016 Environmental management – Environmental technology verification (ETV)

Canadian Environmental Technology Verification (ETV) Program’s **Procedure for Laboratory Testing of Oil-Grit Separators**

1.3 SUBMITTALS

1.3.1 All submittals, including sizing reports & shop drawings, shall be submitted upon request with each order to the contractor then forwarded to the Engineer of Record for review and acceptance. Shop drawings shall detail all OGS components, elevations, and sequence of construction.

1.3.2 Alternative devices shall have features identical to or greater than the specified device, including: treatment chamber diameter, treatment chamber wet volume, sediment storage volume, and oil storage volume.

1.3.3 Unless directed otherwise by the Engineer of Record, OGS stormwater quality treatment product substitutions or alternatives submitted within ten days prior to project bid shall not be accepted. All alternatives or substitutions submitted shall be signed and sealed by a local registered Professional Engineer, based on the exact same criteria detailed in Section 3, in entirety, subject to review and approval by the Engineer of Record.

PART 2 – PRODUCTS

2.1 OGS POLLUTANT STORAGE

The OGS device shall include a sump for sediment storage, and a protected volume for the capture and storage of petroleum hydrocarbons and buoyant gross pollutants. The minimum sediment & petroleum hydrocarbon storage capacity shall be as follows:

| | | |
|-------|-------------------------------------|---|
| 2.1.1 | 4 ft (1219 mm) Diameter OGS Units: | 1.19 m ³ sediment / 265 L oil |
| | 5 ft (1524 mm) Diameter OGS Units: | 1.95 m ³ sediment / 420 L oil |
| | 6 ft (1829 mm) Diameter OGS Units: | 3.48 m ³ sediment / 609 L oil |
| | 8 ft (2438 mm) Diameter OGS Units: | 8.78 m ³ sediment / 1,071 L oil |
| | 10 ft (3048 mm) Diameter OGS Units: | 17.78 m ³ sediment / 1,673 L oil |
| | 12 ft (3657 mm) Diameter OGS Units: | 31.23 m ³ sediment / 2,476 L oil |

PART 3 – PERFORMANCE & DESIGN

3.1 GENERAL

The OGS stormwater quality treatment device shall be verified in accordance with ISO 14034:2016 Environmental management – Environmental technology verification (ETV). The OGS stormwater quality treatment device shall remove oil, sediment and gross pollutants from stormwater runoff during frequent wet weather events, and retain these pollutants during less frequent high flow wet weather events below the insert within the OGS for later removal during maintenance. The Manufacturer shall have at least ten (10) years of local experience, history and success in engineering design, manufacturing and production and supply of OGS stormwater quality treatment device systems, acceptable to the Engineer of Record.

3.2 SIZING METHODOLOGY

The OGS device shall be engineered, designed and sized to provide stormwater quality treatment based on treating a minimum of 90 percent of the average annual runoff volume and a minimum removal of an annual average 60% of the sediment (TSS) load based on the Particle Size Distribution (PSD) specified in the sizing report for the specified device. Sizing of the OGS shall be determined by use of a minimum ten (10) years of local historical rainfall data provided by Environment Canada. Sizing shall also be determined by use of the sediment removal performance data derived from the ISO 14034 ETV third-party verified laboratory testing data from testing conducted in accordance with the Canadian ETV protocol Procedure for Laboratory Testing of Oil-Grit Separators, as follows:

3.2.1 Sediment removal efficiency for a given surface loading rate and its associated flow rate shall be based on sediment removal efficiency demonstrated at the seven (7) tested surface loading rates specified in the protocol, ranging 40 L/min/m² to 1400 L/min/m², and as stated in the ISO 14034 ETV Verification Statement for the OGS device.

3.2.2 Sediment removal efficiency for surface loading rates between 40 L/min/m² and 1400 L/min/m² shall be based on linear interpolation of data between consecutive tested surface loading rates.

3.2.3 Sediment removal efficiency for surface loading rates less than the lowest tested surface loading rate of 40 L/min/m² shall be assumed to be identical to the sediment removal efficiency at 40 L/min/m². No extrapolation shall be allowed that results in a sediment removal efficiency that is greater than that demonstrated at 40 L/min/m².

3.2.4 Sediment removal efficiency for surface loading rates greater than the highest tested surface loading rate of 1400 L/min/m² shall assume zero sediment removal for the portion of flow that exceeds 1400 L/min/m², and shall be calculated using a simple proportioning formula, with 1400 L/min/m² in the numerator and the higher surface loading rate in the denominator, and multiplying the resulting fraction times the sediment removal efficiency at 1400 L/min/m².

The OGS device shall also have sufficient annual sediment storage capacity as specified and calculated in Section 2.1.

3.3 CANADIAN ETV or ISO 14034 ETV VERIFICATION OF SCOUR TESTING

The OGS device shall have Canadian ETV or ISO 14034 ETV Verification of third-party scour testing conducted in accordance with the Canadian ETV Program's **Procedure for Laboratory Testing of Oil-Grit Separators**.

3.3.1 To be acceptable for on-line installation, the OGS device must demonstrate an average scour test effluent concentration less than 10 mg/L at each surface loading rate tested, up to and including 2600 L/min/m².

3.4 LIGHT LIQUID RE-ENTRAINMENT SIMULATION TESTING

The OGS device shall have Canadian ETV or ISO 14034 ETV Verification of completed third-party Light Liquid

Re-entrainment Simulation Testing in accordance with the Canadian ETV **Program's Procedure for Laboratory Testing of Oil-Grit Separators**, with results reported within the Canadian ETV or ISO 14034 ETV verification. This re-entrainment testing is conducted with the device pre-loaded with low density polyethylene (LDPE) plastic beads as a surrogate for light liquids such as oil and fuel. Testing is conducted on the same OGS unit tested for sediment removal to assess whether light liquids captured after a spill are effectively retained at high flow rates.

3.4.1 For an OGS device to be an acceptable stormwater treatment device on a site where vehicular traffic occurs and the potential for an oil or fuel spill exists, the OGS device must have reported verified performance results of greater than 99% cumulative retention of LDPE plastic beads for the five specified surface loading rates (ranging 200 L/min/m² to 2600 L/min/m²) in accordance with the Light Liquid Re-entrainment Simulation Testing within the Canadian ETV Program's **Procedure for Laboratory Testing of Oil-Grit Separators**. However, an OGS device shall not be allowed if the Light Liquid Re-entrainment Simulation Testing was performed with screening components within the OGS device that are effective at retaining the LDPE plastic beads, but would not be expected to retain light liquids such as oil and fuel.

Volume III: TEMPEST INLET CONTROL DEVICES

Municipal Technical
Manual Series



SECOND EDITION

LMF (Low to Medium Flow) ICD

HF (High Flow) ICD

MHF (Medium to High Flow) ICD



IPEX

by aliaxis

IPEX Tempest™ Inlet Control Devices

Municipal Technical Manual Series

Vol. I, 2nd Edition

© 2022 by IPEX. All rights reserved. No part of this book may be used or reproduced in any manner whatsoever without prior written permission.

For information contact: IPEX, Marketing,
1425 North Service Road East, Oakville, Ontario, Canada, L6H 1A7

The information contained here within is based on current information and product design at the time of publication and is subject to change without notification. IPEX does not guarantee or warranty the accuracy, suitability for particular applications, or results to be obtained therefrom.

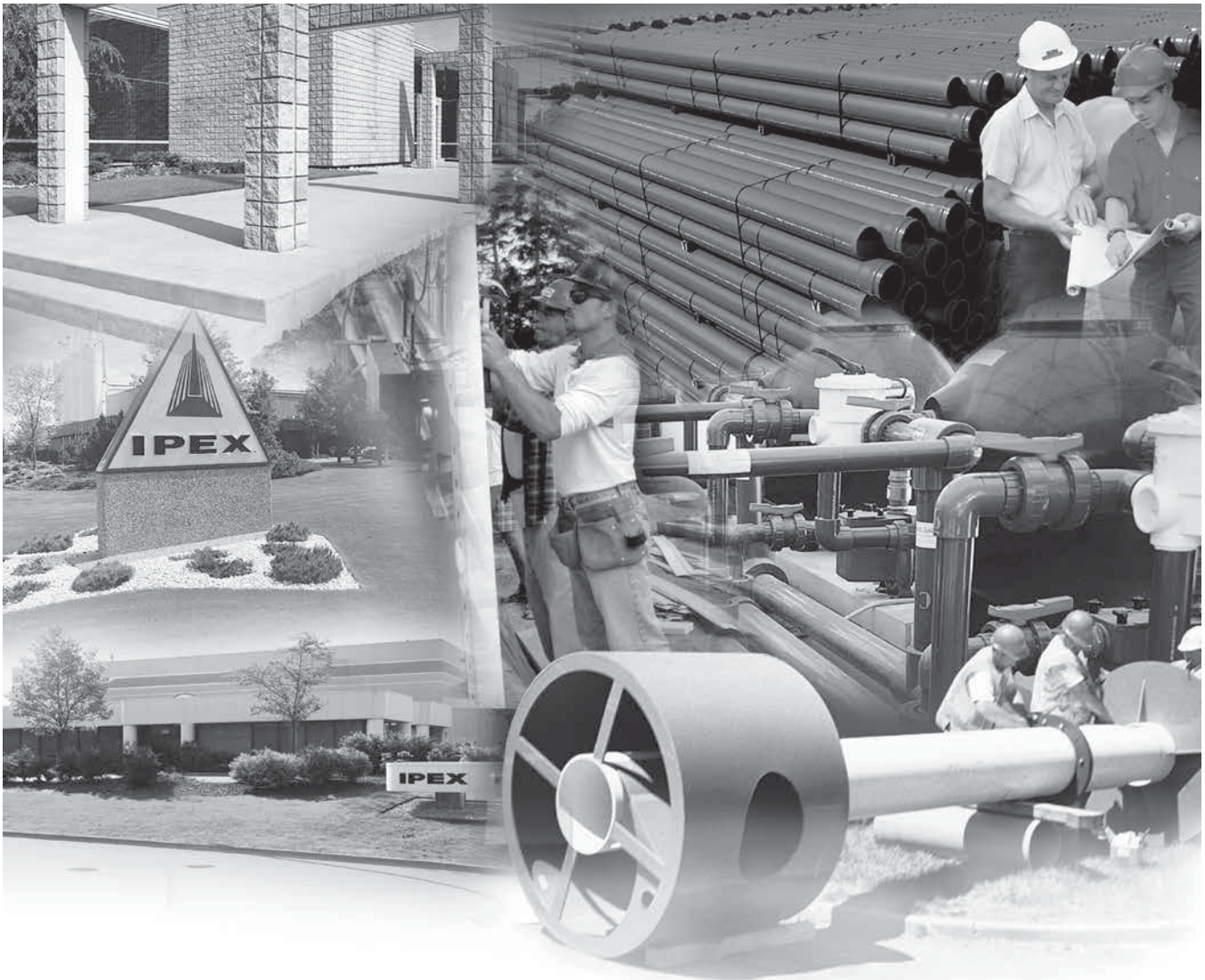

ABOUT IPEX

At IPEX, we have been manufacturing non-metallic pipe and fittings since 1951. We formulate our own compounds and maintain strict quality control during production. Our products are made available for customers thanks to a network of regional stocking locations throughout North America. We offer a wide variety of systems including complete lines of piping, fittings, valves and custom-fabricated items.

More importantly, we are committed to meeting our customers' needs. As a leader in the plastic piping industry, IPEX continually develops new products, modernizes manufacturing facilities and acquires innovative process technology. In addition, our staff take pride in their work, making available to customers their extensive thermoplastic knowledge and field experience. IPEX personnel are committed to improving the safety, reliability and performance of thermoplastic materials. We are involved in several standards committees and are members of and/or comply with the organizations listed on this page.

For specific details about any IPEX product, contact our customer service department.

CONTENTS

TEMPEST INLET CONTROL DEVICES Technical Manual

About IPEX

| | | |
|---------------------|--|----|
| Section One: | Product Information: TEMPEST Low, Medium Flow (LMF) ICD | |
| | Purpose | 4 |
| | Product Description | 4 |
| | Product Function | 4 |
| | Product Construction | 4 |
| | Product Applications | 4 |
| | Chart 1: LMF 14 Preset Flow Curves | 5 |
| | Chart 2: LMF Flow Vs. ICD Alternatives | 5 |
| | Product Installation | |
| | Instructions to assemble a TEMPEST LMF ICD into a square catch basin: | 6 |
| | Instructions to assemble a TEMPEST LMF ICD into a round catch basin: | 6 |
| | Product Technical Specification | |
| | General | 7 |
| | Materials | 7 |
| | Dimensioning | 7 |
| | Installation | 7 |
| Section Two: | Product Information: TEMPEST High Flow (HF) & Medium, High Flow (MHF) ICD | |
| | Product Description | 8 |
| | Product Function | 8 |
| | Product Construction | 8 |
| | Product Applications | 8 |
| | Chart 3: HF & MHF Preset Flow Curves | 9 |
| | Product Installation | |
| | Instructions to assemble a TEMPEST HF or MHF ICD into a square catch basin: | 10 |
| | Instructions to assemble a TEMPEST HF or MHF ICD into a round catch basin: | 10 |
| | Instructions to assemble a TEMPEST HF Sump into a square or round catch basin: ... | 11 |
| | Product Technical Specification | |
| | General | 11 |
| | Materials | 11 |
| | Dimensioning | 11 |
| | Installation | 11 |

PRODUCT INFORMATION: TEMPEST LOW, MEDIUM FLOW (LMF) ICD

Purpose

To control the amount of storm water runoff entering a sewer system by allowing a specified flow volume out of a catch basin or manhole at a specified head. This approach conserves pipe capacity so that catch basins downstream do not become uncontrollably surcharged, which can lead to basement floods, flash floods and combined sewer overflows.

Product Description

Our LMF ICD is designed to accommodate catch basins or manholes with sewer outlet pipes 6" in diameter and larger. Any storm sewer larger than 12" may require custom modification. However, IPEX can custom build a TEMPEST device to accommodate virtually any storm sewer size.

Available in 14 preset flow curves, the LMF ICD has the ability to provide flow rates: 2lps – 17lps (31gpm – 270gpm)

Product Function

The LMF ICD vortex flow action allows the LMF ICD to provide a narrower flow curve using a larger orifice than a conventional orifice plate ICD, making it less likely to clog. When comparing flows at the same head level, the LMF ICD has the ability to restrict more flow than a conventional ICD during a rain event, preserving greater sewer capacity.

Product Construction

Constructed from durable PVC, the LMF ICD is light weight 8.9 Kg (19.7 lbs).

Product Applications

Will accommodate both square and round applications:

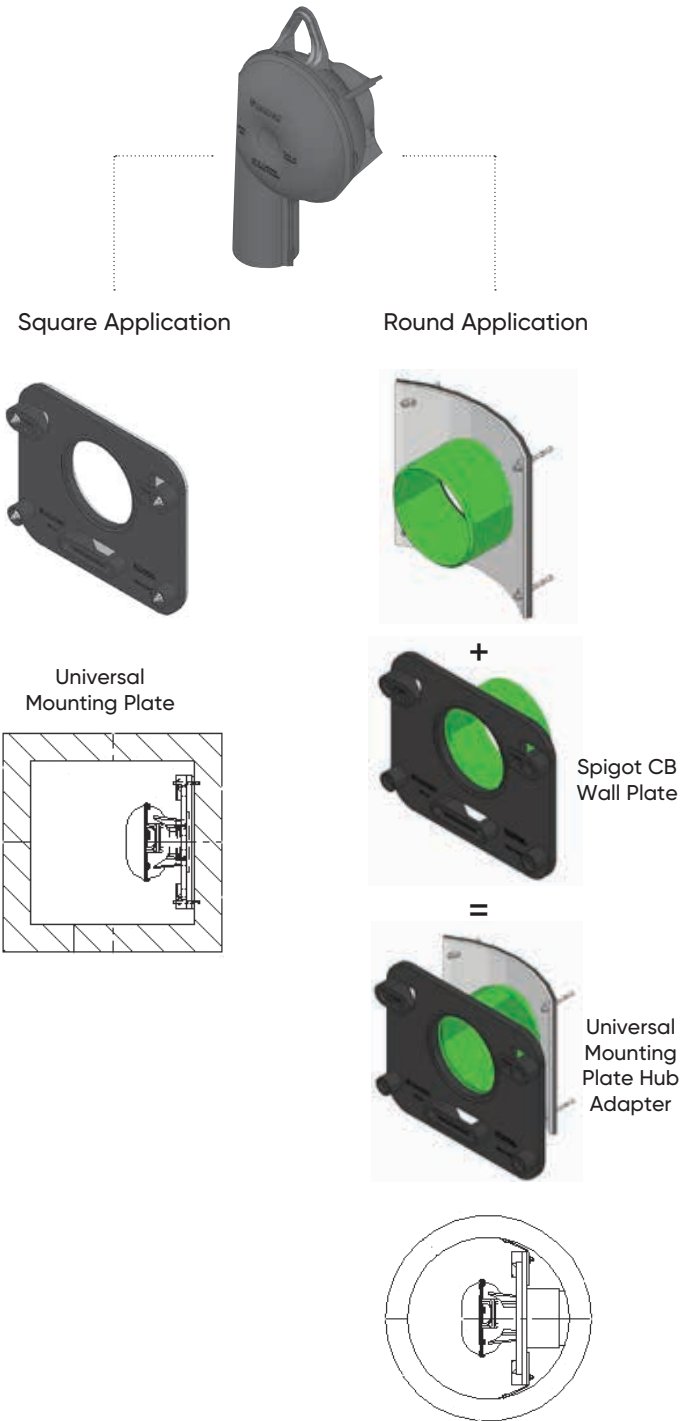

Chart 1: LMF 14 Preset Flow Curves

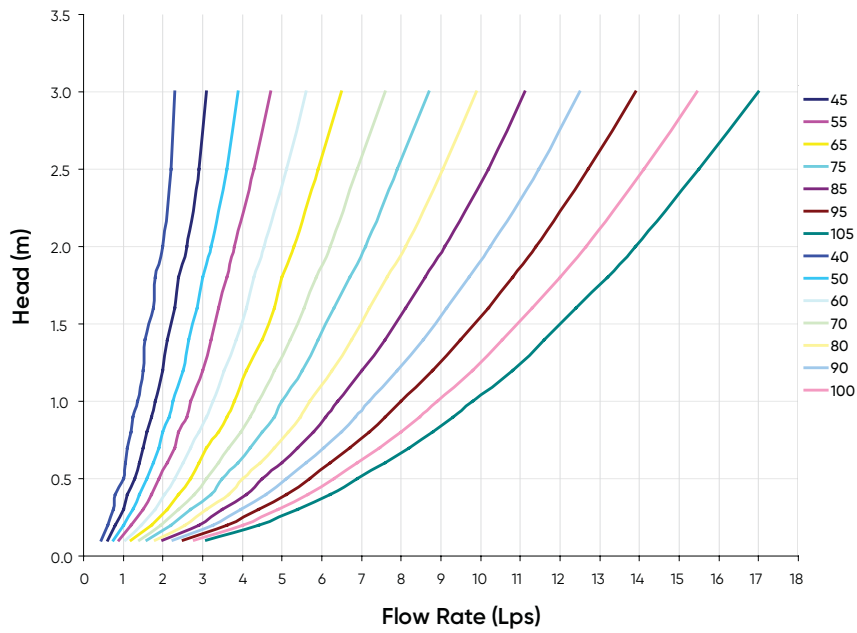
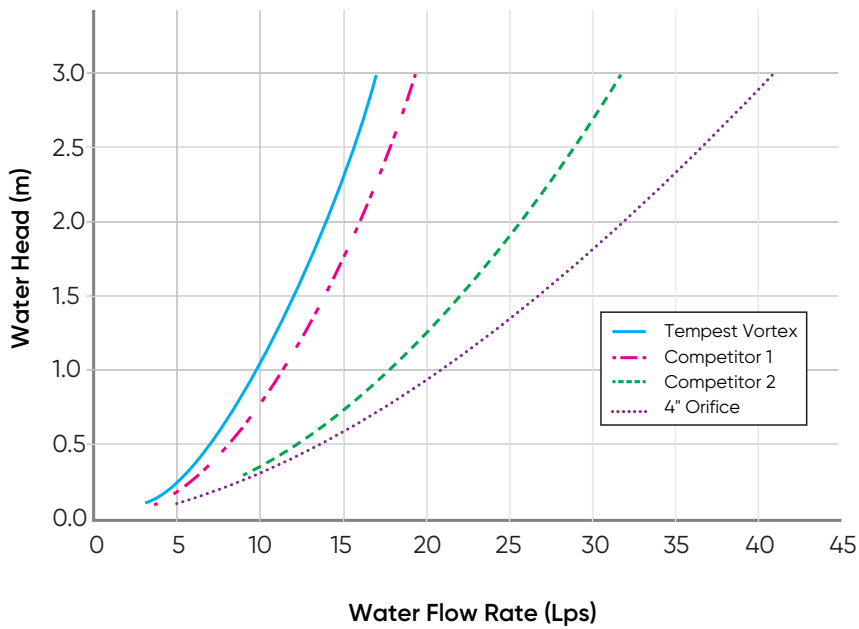

Chart 2: LMF Flow vs. ICD Alternatives



PRODUCT INSTALLATION

Instructions to assemble a TEMPEST LMF ICD into a Square Catch Basin:

STEPS:

1. Materials and tooling verification:
 - Tooling: impact drill, 3/8" concrete bit, torque wrench for 9/16" nut, hand hammer, level, and marker.
 - Material: (4) concrete anchor 3/8 x 3-1/2, (4) washers, (4) nuts, universal mounting plate, ICD device.
2. Use the mounting wall plate to locate and mark the hole (4) pattern on the catch basin wall. You should use a level to ensure that the plate is at the horizontal.
3. Use an impact drill with a 3/8" concrete bit to make the four holes at a minimum of 1-1/2" depth up to 2-1/2". Clean the concrete dust from the holes.
4. Install the anchors (4) in the holes by using a hammer. Thread the nuts on the top of the anchors to protect the threads when you hit the anchors with the hammer. Remove the nuts from the ends of the anchors.
5. Install the universal mounting plate on the anchors and screw the 4 nuts in place with a maximum torque of 40 N.m (30 lbf-ft). There should be no gap between the wall mounting plate and the catch basin wall.
6. From the ground above using a reach bar, lower the ICD device by hooking the end of the reach bar to the handle of the ICD device. Align the triangular plate portion into the mounting wall plate. Push down the device to be sure it has centered in to the universal mounting plate and has created a seal.



WARNING

- Verify that the outlet pipe doesn't protrude into the catch basin. If it does, cut down the pipe flush to the catch basin wall.
- Call your IPEX representative for more information or if you have any questions about our products.

Instructions to assemble a TEMPEST LMF ICD into a Round Catch Basin:

STEPS:

1. Materials and tooling verification.
 - Tooling: impact drill, 3/8" concrete bit, torque wrench for 9/16" nut, hand hammer, level and marker.
 - Material: (4) concrete anchor 3/8 x 3-1/2, (4) washers and (4) nuts, spigot CB wall plate, universal mounting plate hub adapter, ICD device.
2. Use the spigot catch basin wall plate to locate and mark the hole (4) pattern on the catch basin wall. You should use a level to ensure that the plate is at the horizontal.
3. Use an impact drill with a 3/8" concrete bit to make the four holes at a depth between 1-1/2" to 2-1/2". Clean the concrete dust from the holes.
4. Install the anchors (4) in the holes by using a hammer. Thread the nuts on the top of the anchors to protect the threads when you hit the anchors with the hammer. Remove the nuts from the ends of the anchors.
5. Install the CB spigot wall plate on the anchors and screw the 4 nuts in place with a maximum torque of 40 N.m (30 lbf-ft). There should be no gap between the spigot wall plate and the catch basin wall.
6. Apply solvent cement on the hub of the universal mounting plate, hub adapter and the spigot of the CB wall plate, then slide the hub over the spigot. Make sure the universal mounting plate is at the horizontal and its hub is completely inserted onto the spigot. Normally, the corners of the universal mounting plate hub adapter should touch the catch basin wall.
7. From ground above using a reach bar, lower the ICD device by hooking the end of the reach bar to the handle of the ICD device. Align the triangular plate portion into the mounting wall plate. Push down the device to be sure it has centered in to the mounting plate and has created a seal.



WARNING

- Verify that the outlet pipe doesn't protrude into the catch basin. If it does, cut back the pipe flush to the catch basin wall.
- The solvent cement which is used in this installation is to be approved for PVC.
- The solvent cement should not be used below 0°C (32°F) or in a high humidity environment. Refer to the IPEX solvent cement guide to confirm the required curing time or visit the IPEX Online Solvent Cement Training Course available at ipexna.com.
- Call your IPEX representative for more information or if you have any questions about our products.

PRODUCT TECHNICAL SPECIFICATION

General

Inlet control devices (ICD's) are designed to provide flow control at a specified rate for a given water head level and also provide odour and floatable control. All ICD's will be IPEX Tempest or approved equal.

All devices shall be removable from a universal mounting plate. An operator from street level using only a T-bar with a hook will be able to retrieve the device while leaving the universal mounting plate secured to the catch basin wall face. The removal of the TEMPEST devices listed above must not require any unbolting or special manipulation or any special tools.

High Flow (HF) Sump devices will consist of a removable threaded cap which can be accessible from street level with out entry into the catchbasin (CB). The removal of the threaded cap shall not require any special tools other than the operator's hand.

ICD's shall have no moving parts.

Materials

ICD's are to be manufactured from Polyvinyl Chloride (PVC) or Polyurethane material, designed to be durable enough to withstand multiple freeze-thaw cycles and exposure to harsh elements.

The inner ring seal will be manufactured using a Buna or Nitrile material with hardness between Duro 50 and Duro 70.

The wall seal is to be comprised of a 3/8" thick Neoprene Closed Cell Sponge gasket which is attached to the back of the wall plate.

All hardware will be made from 304 stainless steel.

Dimensioning

The Low Medium Flow (LMF), High Flow (HF) and the High Flow (HF) Sump shall allow for a minimum outlet pipe diameter of 200mm with a 600mm deep Catch Basin sump.

Installation

Contractor shall be responsible for securing, supporting and connecting the ICD's to the existing influent pipe and catchbasin/manhole structure as specified and designed by the Engineer.

PRODUCT INFORMATION: TEMPEST HF & MHF ICD

Product Description

Our HF, HF Sump and MHF ICD's are designed to accommodate catch basins or manholes with sewer outlet pipes 6" in diameter or larger. Any storm sewer larger than 12" may require custom modification. However, IPEX can custom build a TEMPEST device to accommodate virtually any storm sewer size.

Available in 5 preset flow curves, these ICDs have the ability to provide constant flow rates: 9lps (143 gpm) and greater

Product Function

TEMPEST HF (High Flow): designed to manage moderate to higher flows 15 L/s (240 gpm) or greater and prevent the propagation of odour and floatables. With this device, the cross-sectional area of the device is larger than the orifice diameter and has been designed to limit head losses. The HF ICD can also be ordered without flow control when only odour and floatable control is required.



TEMPEST HF (High Flow) Sump: The height of a sewer outlet pipe in a catch basin is not always conveniently located. At times it may be located very close to the catch basin floor, not providing enough sump for one of the other TEMPEST ICDs with universal back plate to be installed. In these applications, the HF Sump is offered. The HF Sump offers the same features and benefits as the HF ICD; however, is designed to raise the outlet in a square or round catch basin structure. When installed, the HF sump is fixed in place and not easily removed. Any required service to the device is performed through a clean-out located in the top of the device which can be often accessed from ground level.



TEMPEST MHF (Medium to High Flow): The MHF plate or plug is designed to control flow rates 9 L/s (143 gpm) or greater. It is not designed to prevent the propagation of odour and floatables.



Product Construction

The HF, HF Sump and MHF ICDs are built to be light weight at a maximum weight of 6.8 Kg (14.6 lbs).

Product Applications

The HF and MHF ICD's are available to accommodate both square and round applications:

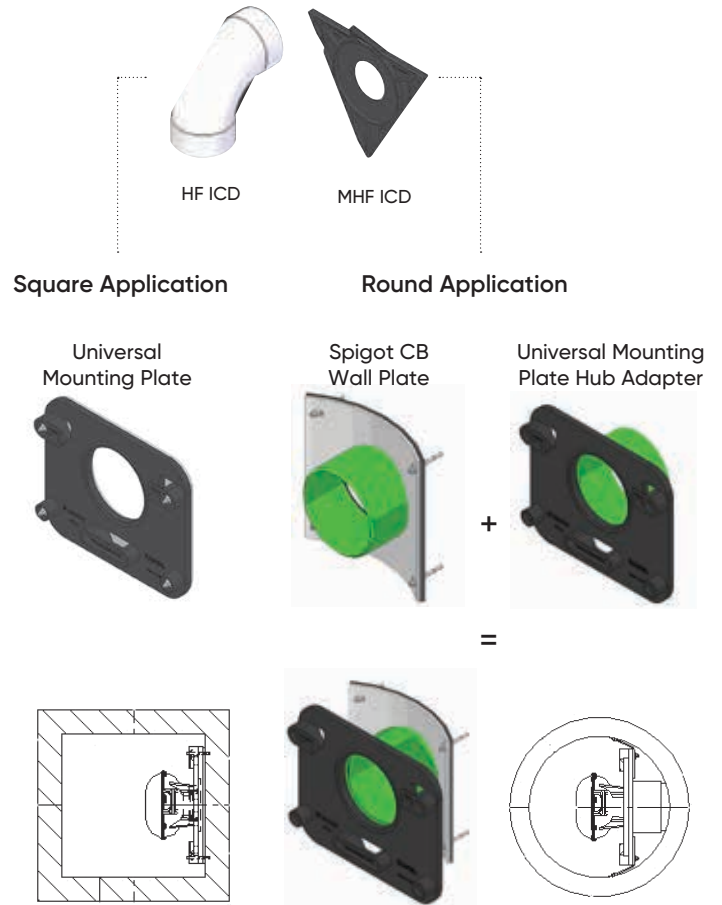

The HF Sump is available to accommodate low to no sump applications in both square and round catch basins:

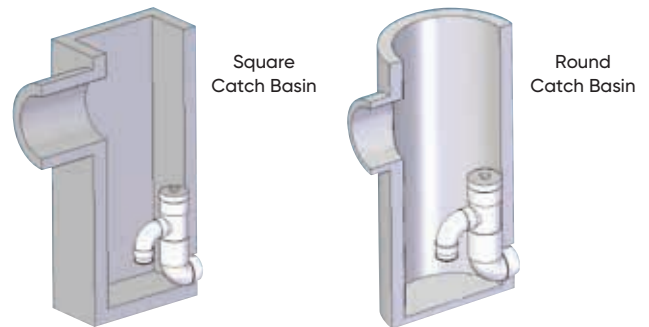
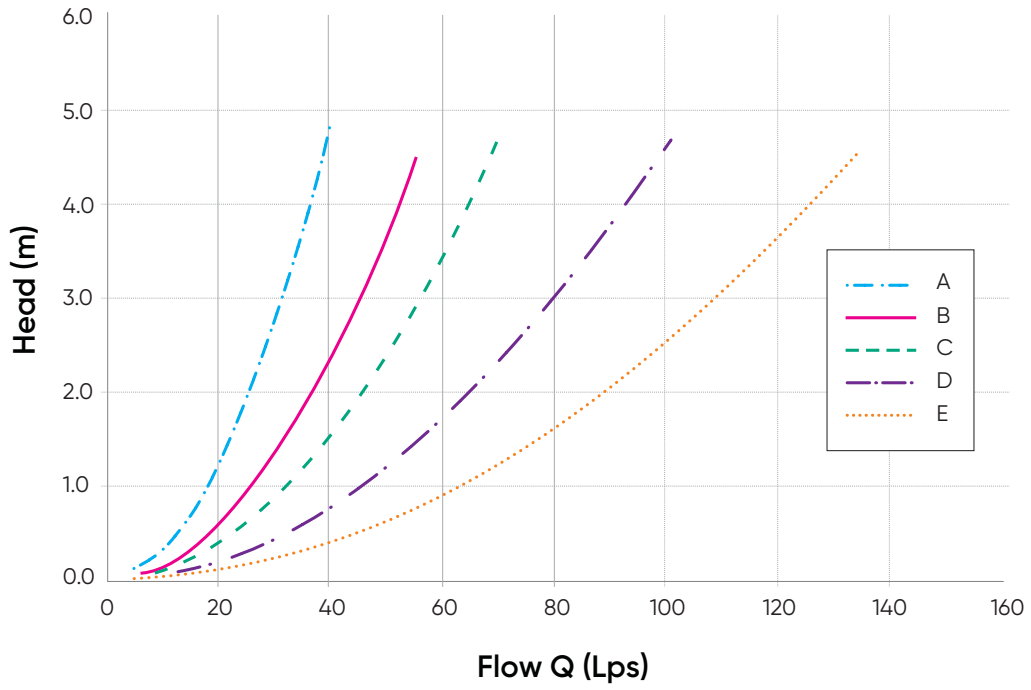

Chart 3: HF & MHF Preset Flow Curves



PRODUCT INSTALLATION

Instructions to assemble a TEMPEST HF or MHF ICD into a Square Catch Basin:

1. Materials and tooling verification:
 - Tooling: impact drill, 3/8" concrete bit, torque wrench for 9/16" nut, hand hammer, level, and marker.
 - Material: (4) concrete anchor 3/8 x 3-1/2, (4) washers, (4) nuts, universal mounting plate, ICD device
2. Use the mounting wall plate to locate and mark the hole (4) pattern on the catch basin wall. You should use a level to ensure that the plate is at the horizontal.
3. Use an impact drill with a 3/8" concrete bit to make the four holes at a minimum of 1-1/2" depth up to 2-1/2". Clean the concrete dust from the holes.
4. Install the anchors (4) in the holes by using a hammer. Thread the nuts on the top of the anchors to protect the threads when you hit the anchors with the hammer. Remove the nuts from the ends of the anchors.
5. Install the universal wall mounting plate on the anchors and screw the 4 nuts in place with a maximum torque of 40 N.m (30 lbf-ft). There should be no gap between the wall mounting plate and the catch basin wall.
6. From the ground above using a reach bar, lower the device by hooking the end of the reach bar to the handle of the ICD device. Align the triangular plate portion into the mounting wall plate. Push down the device to be sure it has centered in to the universal wall mounting plate and has created a seal.



WARNING

- Verify that the outlet pipe doesn't protrude into the catch basin. If it does, cut down the pipe flush to the catch basin wall.
- Call your IPEX representative for more information or if you have any questions about our products.

Instructions to assemble a TEMPEST HF or MHF ICD into a Round Catch Basin:

STEPS:

1. Materials and tooling verification.
 - Tooling: impact drill, 3/8" concrete bit, torque wrench for 9/16" nut, hand hammer, level and marker.
 - Material: (4) concrete anchor 3/8 x 3-1/2, (4) washers and (4) nuts, spigot CB wall plate, universal mounting plate hub adapter, ICD device.
2. Use the round catch basin spigot adaptor to locate and mark the hole (4) pattern on the catch basin wall. You should use a level to ensure that the plate is at the horizontal.
3. Use an impact drill with a 3/8" concrete bit to make the four holes at a depth between 1-1/2" to 2-1/2". Clean the concrete dust from the holes.
4. Install the anchors (4) in the holes by using a hammer. Thread the nuts on the top of the anchors to protect the threads when you hit the anchors with the hammer. Remove the nuts from the ends of the anchors.
5. Install the spigot CB wall plate on the anchors and screw the 4 nuts in place with a maximum torque of 40 N.m (30 lbf-ft). There should be no gap between the spigot CB wall plate and the catch basin wall.
6. Put solvent cement on the hub of the universal mounting plate, hub adapter and the spigot of the CB wall plate, then slide the hub over the spigot. Make sure the universal mounting plate is at the horizontal and its hub is completely inserted onto the spigot. Normally, the corners of the hub adapter should touch the catch basin wall.
7. From ground above using a reach bar, lower the device by hooking the end of the reach bar to the handle of the ICD device. Align the triangular plate portion into the mounting wall plate. Push down the device to be sure it has centered in to the wall mounting plate and has created a seal.



WARNING

- Verify that the outlet pipe doesn't protrude into the catch basin. If it does, cut down the pipe flush to the catch basin wall.
- The solvent cement which is used in this installation is to be approved for PVC.
- The solvent cement should not be used below 0°C (32°F) or in a high humidity environment. Refer to the IPEX solvent cement guide to confirm the required curing time or visit the IPEX Online Solvent Cement Training Course available at www.ipexinc.com.
- Call your IPEX representative for more information or if you have any questions about our products.

Instructions to assemble a TEMPEST HF Sump into a Square or Round Catch Basin:

STEPS:

1. Materials and tooling verification:
 - Tooling: impact drill, 3/8" concrete bit, torque wrench for 9/16" nut, hand hammer, level, mastic tape and metal strapping
 - Material: (2) concrete anchor 3/8 x 3-1/2, (2) washers, (2) nuts, HF Sump pieces (2).
2. Apply solvent cement to the spigot end of the top half of the sump. Apply solvent cement to the hub of the bottom half of the sump. Insert the spigot of the top half of the sump into the hub of the bottom half of the sump.
3. Install the 8" spigot of the device into the outlet pipe. Use the mastic tape to seal the device spigot into the outlet pipe. You should use a level to be sure that the fitting is standing at the vertical.
4. Use an impact drill with a 3/8" concrete bit to make a series of 2 holes along each side of the body throat. The depth of the hole should be between 1-1/2" to 2-1/2". Clean the concrete dust from the 2 holes.
5. Install the anchors (2) in the holes by using a hammer. Put the nuts on the top of the anchors to protect the threads when you hit the anchors. Remove the nuts from the ends of the anchors.
6. Cut the metal strapping to length and connect each end of the strapping to the anchors. Screw the nuts in place with a maximum torque of 40 N.m (30 lbf-ft). The device should be completely flush with the catch basin wall.



WARNING

- Verify that the outlet pipe doesn't protrude into the catch basin. If it does, cut down the pipe flush to the catch basin wall.
- The solvent cement which is used in this installation is to be approved for PVC.
- The solvent cement should not be used below 0°C (32°F) or in a high humidity environment. Refer to the IPEX solvent cement guide to confirm the required curing time or visit the IPEX Online Solvent Cement Training Course available at www.ipexinc.com.
- Call your IPEX representative for more information or if you have any questions about our products.

PRODUCT TECHNICAL SPECIFICATION

General

Inlet control devices (ICD's) are designed to provide flow control at a specified rate for a given water head level and also provide odour and floatable control where specified. All ICD's will be IPEX Tempest or approved equal.

All devices shall be removable from a universal mounting plate. An operator from street level using only a T-bar with a hook shall be able to retrieve the device while leaving the universal mounting plate secured to the catch basin wall face. The removal of the TEMPEST devices listed above shall not require any unbolting or special manipulation or any special tools.

High Flow (HF) Sump devices shall consist of a removable threaded cap which can be accessible from street level with out entry into the catchbasin (CB). The removal of the threaded cap shall not require any special tools other than the operator's hand.

ICD's shall have no moving parts.

Materials

ICD's are to be manufactured from Polyvinyl Chloride (PVC) or Polyurethane material, designed to be durable enough to withstand multiple freeze-thaw cycles and exposure to harsh elements.

The inner ring seal will be manufactured using a Buna or Nitrile material with hardness between Duro 50 and Duro 70.

The wall seal is to be comprised of a 3/8" thick Neoprene Closed Cell Sponge gasket which is attached to the back of the wall plate.

All hardware will be made from 304 stainless steel.

Dimensioning

The Low Medium Flow (LMF), High Flow (HF) and the High Flow (HF) Sump shall allow for a minimum outlet pipe diameter of 200mm with a 600mm deep Catch Basin sump.

Installation

Contractor shall be responsible for securing, supporting and connecting the ICD's to the existing influent pipe and catchbasin/manhole structure as specified and designed by the Engineer.

NOTES

SALES AND CUSTOMER SERVICE

IPEX Inc.

Toll Free: (866) 473-9462

ipexna.com

About the IPEX Group of Companies

As leading suppliers of thermoplastic piping systems, the IPEX Group of Companies provides our customers with some of the largest and most comprehensive product lines. All IPEX products are backed by more than 50 years of experience. With state-of-the-art manufacturing facilities and distribution centers across North America, we have established a reputation for product innovation, quality, end-user focus and performance.

Markets served by IPEX group products are:

- Electrical systems
- Telecommunications and utility piping systems
- PVC, CPVC, PP, ABS, PEX, FR-PVDF and PE pipe and fittings (1/4" to 48")
- Industrial process piping systems
- Municipal pressure and gravity piping systems
- Plumbing and mechanical piping systems
- PE Electrofusion systems for gas and water
- Industrial, plumbing and electrical cements
- Irrigation systems

Products manufactured by IPEX Inc.

Tempest™ is a trademark of IPEX Branding Inc.

This literature is published in good faith and is believed to be reliable. However it does not represent and/or warrant in any manner the information and suggestions contained in this brochure. Data presented is the result of laboratory tests and field experience.

A policy of ongoing product improvement is maintained. This may result in modifications of features and/or specifications without notice.



APPENDIX F
PRE-DEVELOPMENT DRAWING



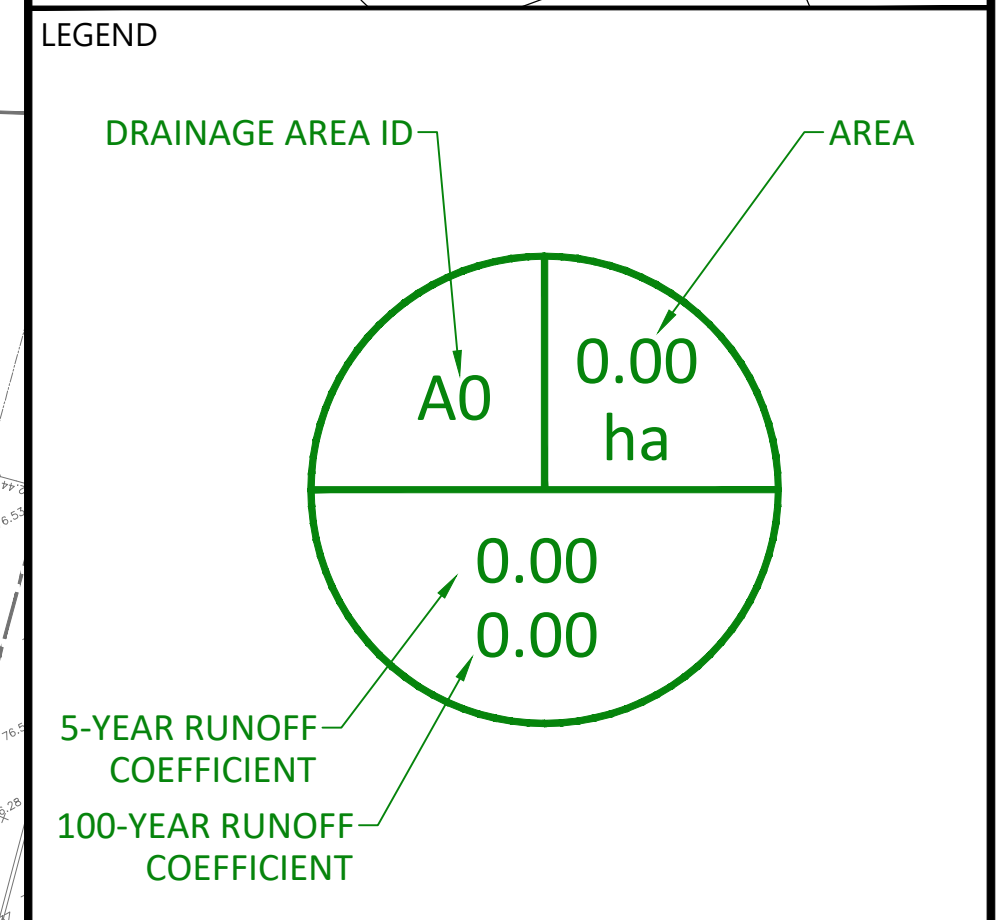
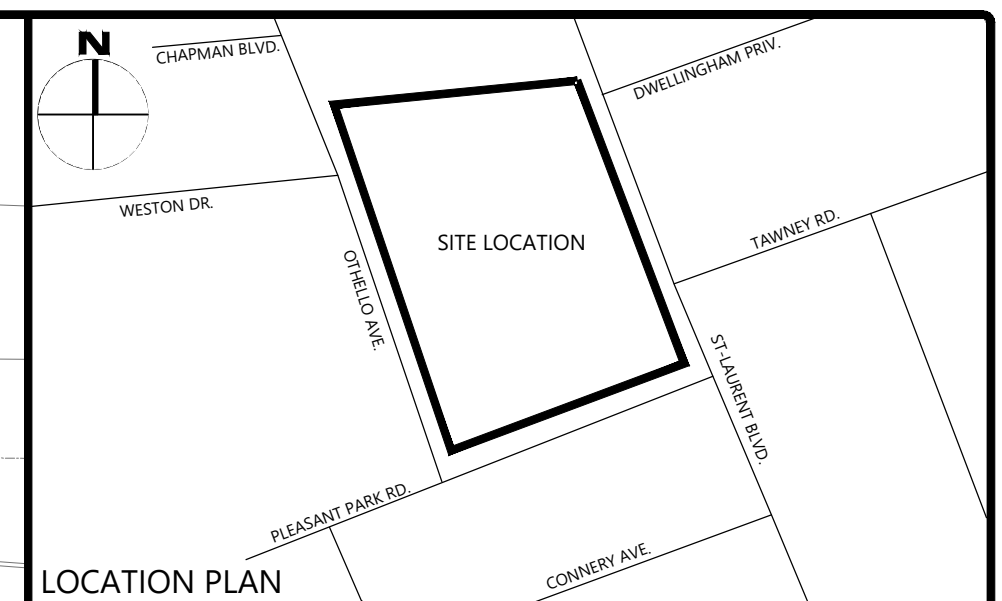
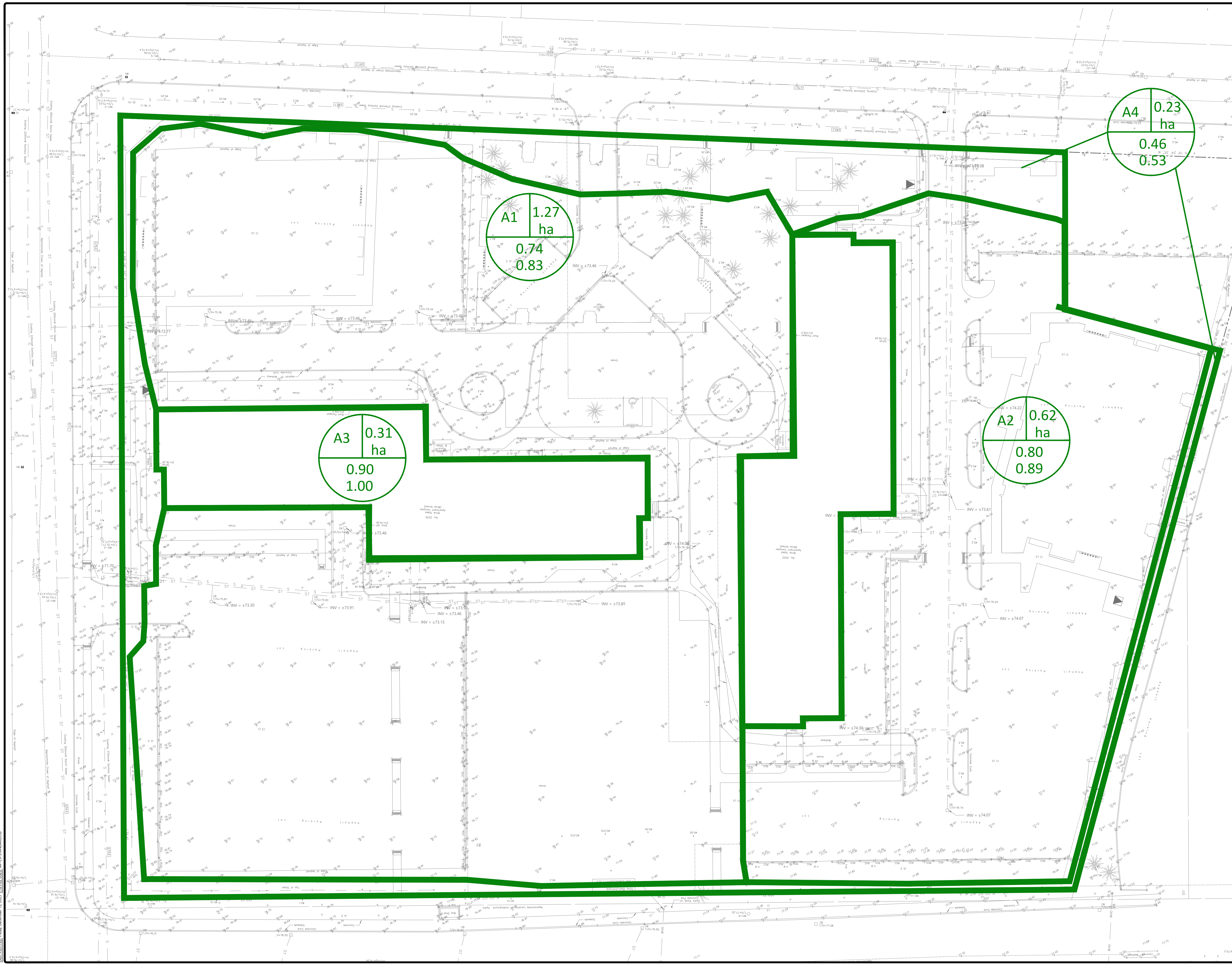

FOR REVIEW ONLY
 NOT FOR CONSTRUCTION

| No. | Revisions | Date |
|-----|-----------|------|
| | | |
| | | |
| | | |
| | | |
| | | |
| | | |
| | | |
| | | |
| | | |
| | | |

Check and verify all dimensions before proceeding with the work. Do not scale drawings.

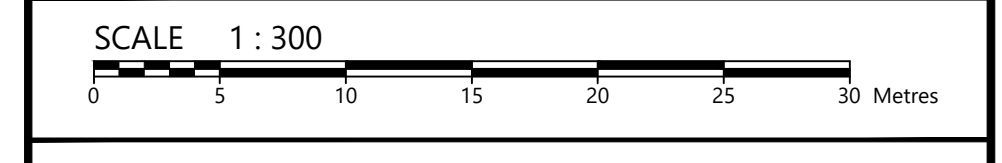

egis 115 Walgreen Road, R.R.3
 Carp, ON K0A 1L0
 Tel: 613-836-2184
 Fax: 613-836-3742
 www.egis-group.com

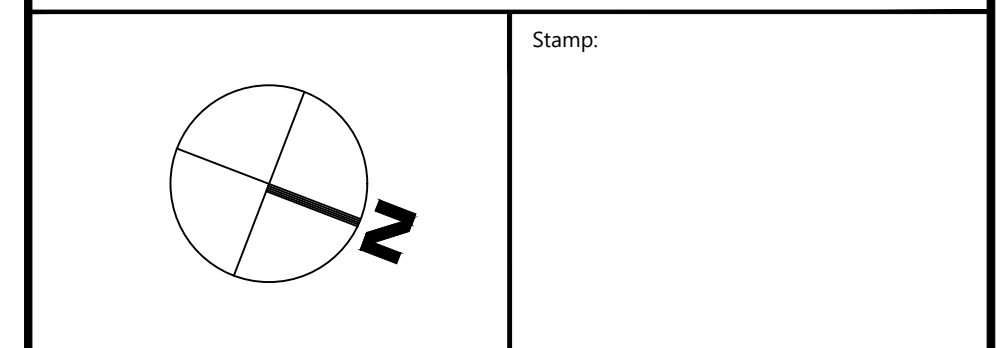

Client: **OSGOODE PROPERTIES**
 1284 WELLINGTON STREET WEST
 OTTAWA, ON K1Y 3A9

Project: **OSGOODE STACKS**
 2025 OHELLO AVENUE
 OTTAWA ON

Drawing Title: **PRE-DEVELOPMENT DRAINAGE PLAN**

| | |
|--------------|-----------------------------|
| Scale: 1:300 | Project Number: CCO-22-1241 |
| Drawn By: | Checked By: |
| Designed By: | Drawing Number: |

I:\MAMEL\U\Ottawa\03\Project - Proposals\2022\03\CCO\CO-22-1241 - Osgoode Properties - 2022\Oshello_Av115_Drainp_L1.dwg
 2022 OCTOBER 12 Friday 10:05:41 AM
 I:\MAMEL\U\Ottawa\03\Project - Proposals\2022\03\CCO\CO-22-1241 - Osgoode Properties - 2022\Oshello_Av115_Drainp_L1.dwg

D07-12-XX-XXXX
 PRE

APPENDIX G
POST DEVELOPMENT



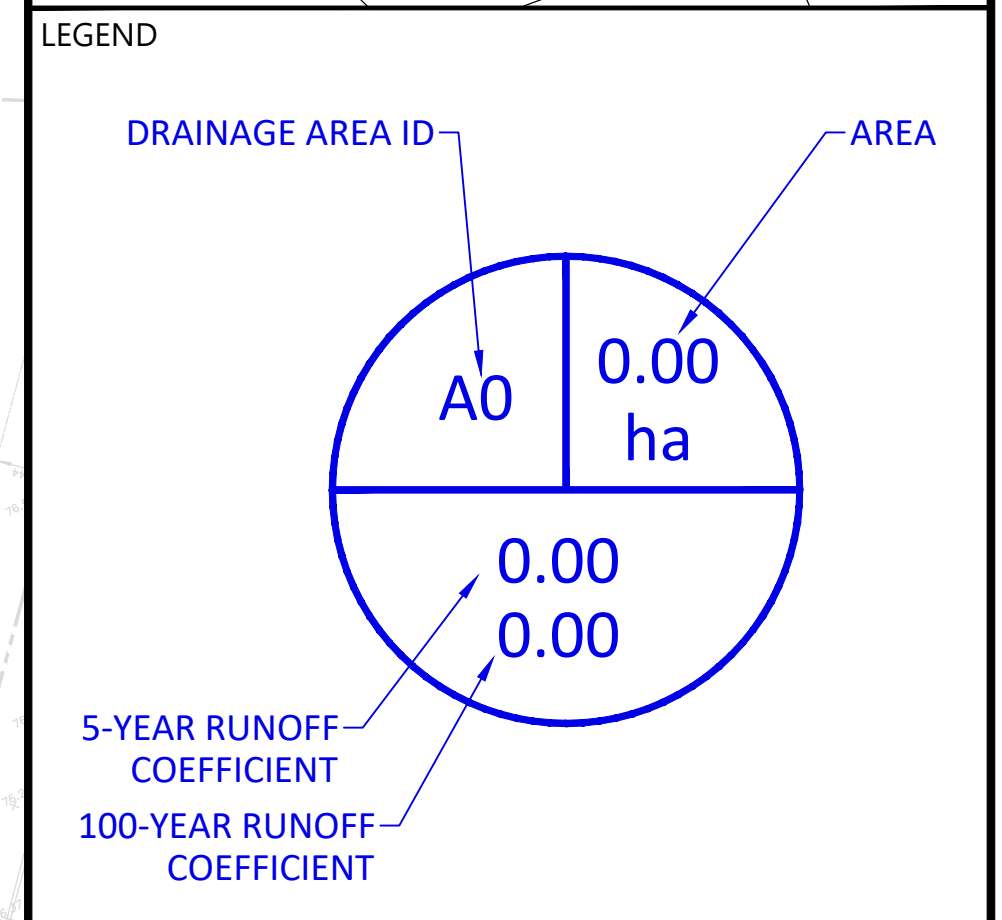
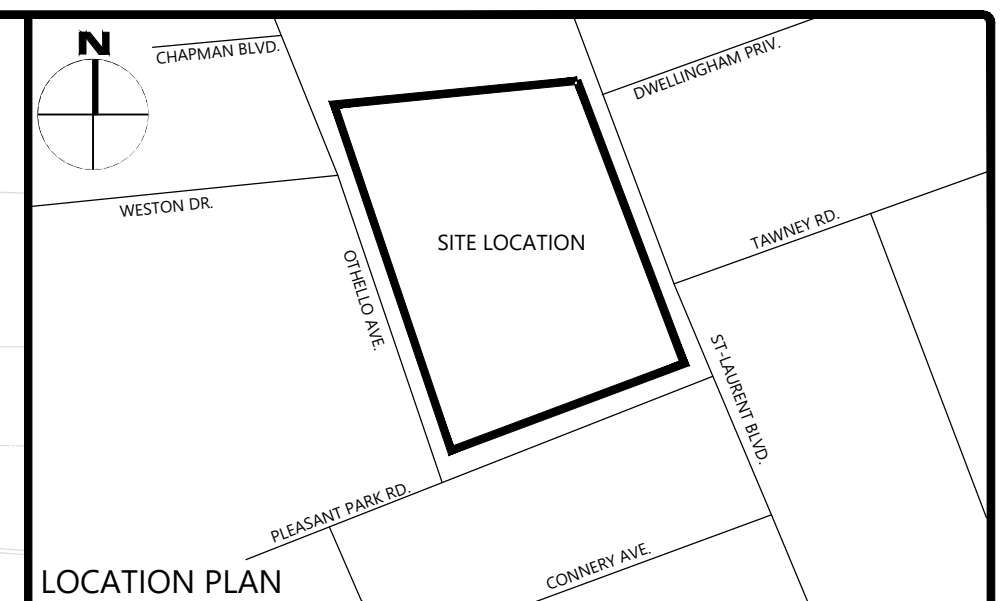
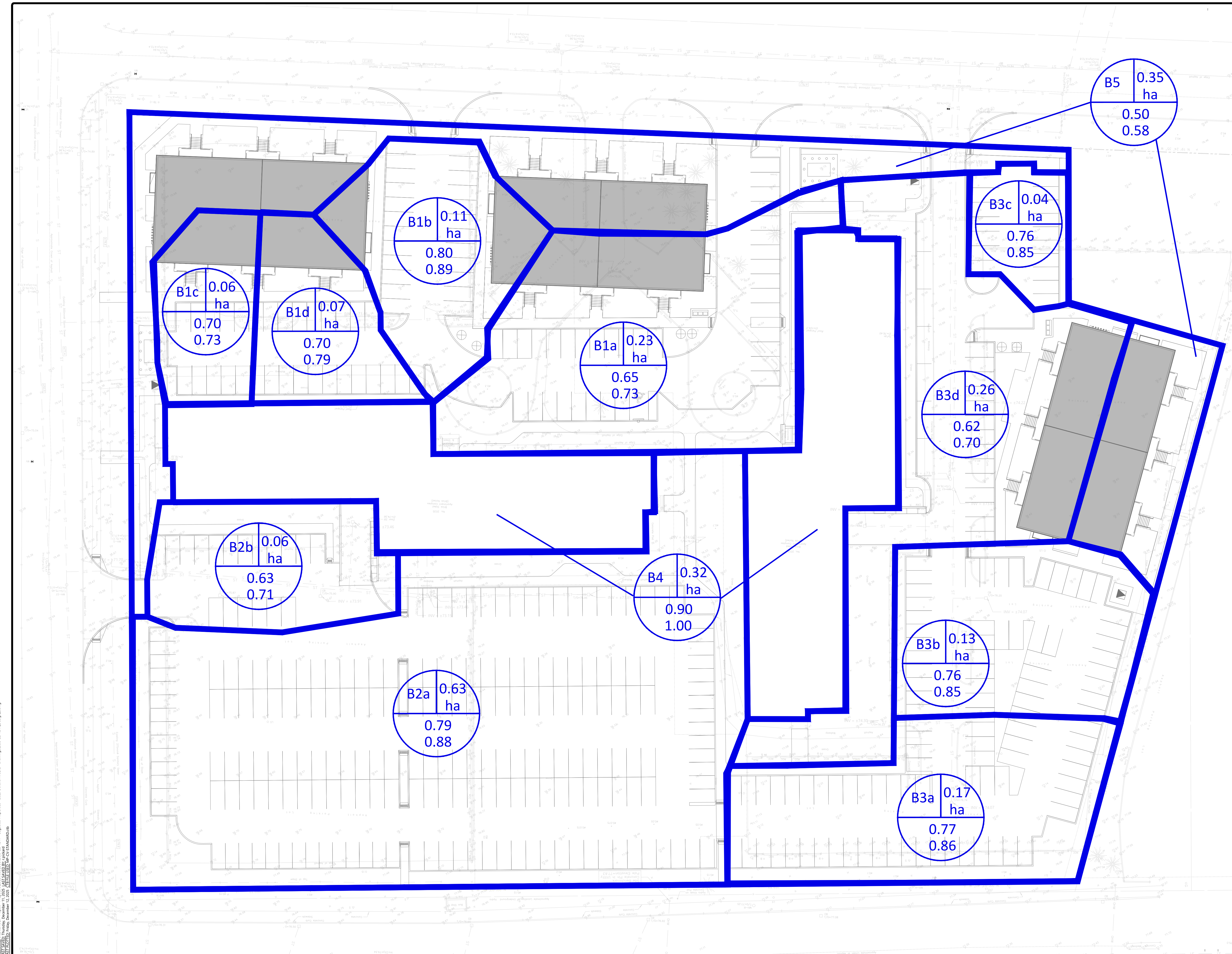

FOR REVIEW ONLY
NOT FOR CONSTRUCTION

| No. | Revisions | Date |
|-----|-----------|------|
| | | |
| | | |
| | | |
| | | |
| | | |

Check and verify all dimensions before proceeding with the work. Do not scale drawings.

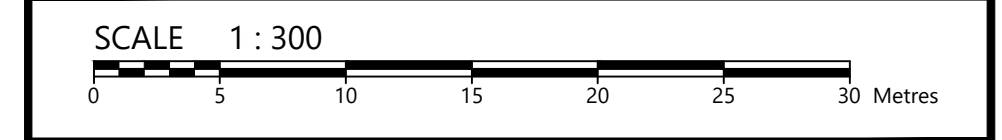

115 Walgreen Road, R.R.3
Carp, ON K0A 1L0
Tel: 613-836-2184
Fax: 613-836-3742
www.egis-group.com

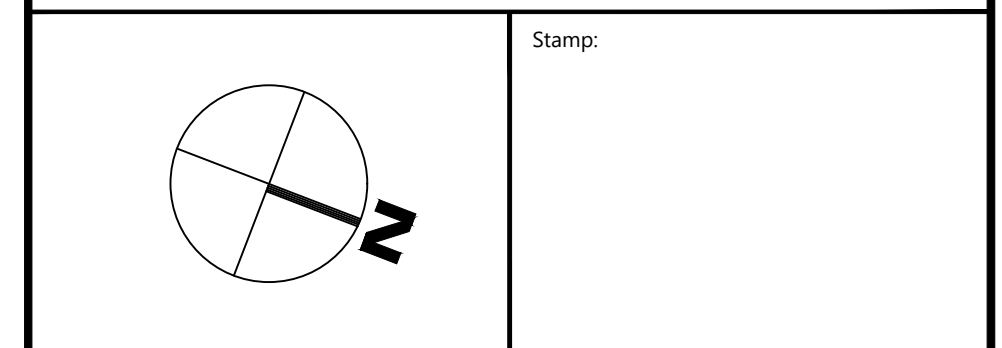

Client: **OSGOODE PROPERTIES**
1284 WELLINGTON STREET WEST
OTTAWA, ON K1Y 3A9

Project: **OSGOODE STACKS**
2025 OTHELLO AVENUE
OTTAWA ON

Drawing Title: **PRE-DEVELOPMENT DRAINAGE PLAN**

| | |
|--------------|-----------------------------|
| Scale: 1:300 | Project Number: CCO-22-1241 |
| Drawn By: | Checked By: |
| Designed By: | Drawing Number: |

PRE

ALL RIGHTS RESERVED. Project: Pre-development Drainage Plan - 2025 Othello Ave. Drawing: CCO-22-1241-Drainage Plan
 DATE: 2025-01-14 10:00 AM. DRAWN BY: J. [Name]. CHECKED BY: [Name]. DESIGNED BY: [Name].

D07-12-XX-XXXX

#XXXXX

APPENDIX H
CITY OF OTTAWA DESIGN CHECKLIST



City of Ottawa

4. Development Servicing Study Checklist

The following section describes the checklist of the required content of servicing studies. It is expected that the proponent will address each one of the following items for the study to be deemed complete and ready for review by City of Ottawa Infrastructure Approvals staff.

The level of required detail in the Servicing Study will increase depending on the type of application. For example, for Official Plan amendments and re-zoning applications, the main issues will be to determine the capacity requirements for the proposed change in land use and confirm this against the existing capacity constraint, and to define the solutions, phasing of works and the financing of works to address the capacity constraint. For subdivisions and site plans, the above will be required with additional detailed information supporting the servicing within the development boundary.

4.1 General Content

| Criteria | Location (if applicable) |
|---|---|
| <input type="checkbox"/> Executive Summary (for larger reports only). | N/A |
| <input type="checkbox"/> Date and revision number of the report. | On Cover |
| <input type="checkbox"/> Location map and plan showing municipal address, boundary, and layout of proposed development. | Appendix A |
| <input type="checkbox"/> Plan showing the site and location of all existing services. | N/A |
| <input type="checkbox"/> Development statistics, land use, density, adherence to zoning and official plan, and reference to applicable subwatershed and watershed plans that provide context to which individual developments must adhere. | 1.1 Purpose 1.2 Site Description 6.0 Storm Sewer Design |
| <input type="checkbox"/> Summary of pre-consultation meetings with City and other approval agencies. | Appendix B |
| <input type="checkbox"/> Reference and confirm conformance to higher level studies and reports (Master Servicing Studies, Environmental Assessments, Community Design Plans), or in the case where it is not in conformance, the proponent must provide justification and develop a defensible design criteria. | 1.1 Purpose 1.2 Site Description 6.0 Storm Sewer Design |
| <input type="checkbox"/> Statement of objectives and servicing criteria. | 3.0 Pre-Consultation Summary |

| | |
|---|-----|
| <input type="checkbox"/> Identification of existing and proposed infrastructure available in the immediate area. | N/A |
| <input type="checkbox"/> Identification of Environmentally Significant Areas, watercourses and Municipal Drains potentially impacted by the proposed development (Reference can be made to the Natural Heritage Studies, if available). | N/A |
| <input type="checkbox"/> Concept level master grading plan to confirm existing and proposed grades in the development. This is required to confirm the feasibility of proposed stormwater management and drainage, soil removal and fill constraints, and potential impacts to neighbouring properties. This is also required to confirm that the proposed grading will not impede existing major system flow paths. | N/A |
| <input type="checkbox"/> Identification of potential impacts of proposed piped services on private services (such as wells and septic fields on adjacent lands) and mitigation required to address potential impacts. | N/A |
| <input type="checkbox"/> Proposed phasing of the development, if applicable. | N/A |
| <input type="checkbox"/> Reference to geotechnical studies and recommendations concerning servicing. | N/A |
| <input type="checkbox"/> All preliminary and formal site plan submissions should have the following information: <ul style="list-style-type: none"> ○ Metric scale ○ North arrow (including construction North) ○ Key plan ○ Name and contact information of applicant and property owner ○ Property limits including bearings and dimensions ○ Existing and proposed structures and parking areas ○ Easements, road widening and rights-of-way ○ Adjacent street names | N/A |

4.2 Development Servicing Report: Water

| Criteria | Location (if applicable) |
|---|--|
| <input type="checkbox"/> Confirm consistency with Master Servicing Study, if available | N/A |
| <input type="checkbox"/> Availability of public infrastructure to service proposed development | N/A |
| <input type="checkbox"/> Identification of system constraints | N/A |
| <input type="checkbox"/> Identify boundary conditions | Appendix C |
| <input type="checkbox"/> Confirmation of adequate domestic supply and pressure | N/A |
| <input type="checkbox"/> Confirmation of adequate fire flow protection and confirmation that fire flow is calculated as per the Fire Underwriter's Survey. Output should show available fire flow at locations throughout the development. | Appendix C |
| <input type="checkbox"/> Provide a check of high pressures. If pressure is found to be high, an assessment is required to confirm the application of pressure reducing valves. | N/A |
| <input type="checkbox"/> Definition of phasing constraints. Hydraulic modeling is required to confirm servicing for all defined phases of the project including the ultimate design | N/A |
| <input type="checkbox"/> Address reliability requirements such as appropriate location of shut-off valves | N/A |
| <input type="checkbox"/> Check on the necessity of a pressure zone boundary modification. | N/A |
| <input type="checkbox"/> Reference to water supply analysis to show that major infrastructure is capable of delivering sufficient water for the proposed land use. This includes data that shows that the expected demands under average day, peak hour and fire flow conditions provide water within the required pressure range | Appendix C, Section 4.2 Proposed Water Servicing |

| | |
|---|----------------------------|
| <input type="checkbox"/> Description of the proposed water distribution network, including locations of proposed connections to the existing system, provisions for necessary looping, and appurtenances (valves, pressure reducing valves, valve chambers, and fire hydrants) including special metering provisions. | Site Servicing Plan (C101) |
| <input type="checkbox"/> Description of off-site required feeder mains, booster pumping stations, and other water infrastructure that will be ultimately required to service proposed development, including financing, interim facilities, and timing of implementation. | N/A |
| <input type="checkbox"/> Confirmation that water demands are calculated based on the City of Ottawa Design Guidelines. | Appendix C |
| <input type="checkbox"/> Provision of a model schematic showing the boundary conditions locations, streets, parcels, and building locations for reference. | N/A |

4.3 Development Servicing Report: Wastewater

| Criteria | Location (if applicable) |
|--|---|
| <input type="checkbox"/> Summary of proposed design criteria (Note: Wet-weather flow criteria should not deviate from the City of Ottawa Sewer Design Guidelines. Monitored flow data from relatively new infrastructure cannot be used to justify capacity requirements for proposed infrastructure). | N/A |
| <input type="checkbox"/> Confirm consistency with Master Servicing Study and/or justifications for deviations. | N/A |
| <input type="checkbox"/> Consideration of local conditions that may contribute to extraneous flows that are higher than the recommended flows in the guidelines. This includes groundwater and soil conditions, and age and condition of sewers. | N/A |
| <input type="checkbox"/> Description of existing sanitary sewer available for discharge of wastewater from proposed development. | Section 5.2 Proposed Sanitary Servicing |

| | |
|---|---|
| <input type="checkbox"/> Verify available capacity in downstream sanitary sewer and/or identification of upgrades necessary to service the proposed development. (Reference can be made to previously completed Master Servicing Study if applicable) | Section 5.2 Proposed Sanitary Servicing |
| <input type="checkbox"/> Calculations related to dry-weather and wet-weather flow rates from the development in standard MOE sanitary sewer design table (Appendix 'C') format. | N/A |
| <input type="checkbox"/> Description of proposed sewer network including sewers, pumping stations, and forcemains. | Section 5.2 Proposed Sanitary Servicing |
| <input type="checkbox"/> Discussion of previously identified environmental constraints and impact on servicing (environmental constraints are related to limitations imposed on the development in order to preserve the physical condition of watercourses, vegetation, soil cover, as well as protecting against water quantity and quality). | N/A |
| <input type="checkbox"/> Pumping stations: impacts of proposed development on existing pumping stations or requirements for new pumping station to service development. | N/A |
| <input type="checkbox"/> Forcemain capacity in terms of operational redundancy, surge pressure and maximum flow velocity. | N/A |
| <input type="checkbox"/> Identification and implementation of the emergency overflow from sanitary pumping stations in relation to the hydraulic grade line to protect against basement flooding. | N/A |
| <input type="checkbox"/> Special considerations such as contamination, corrosive environment etc. | N/A |

4.4 Development Servicing Report: Stormwater Checklist

| Criteria | Location (if applicable) |
|---|--|
| <input type="checkbox"/> Description of drainage outlets and downstream constraints including legality of outlets (i.e. municipal drain, right-of-way, watercourse, or private property) | Section 6.0 Storm Sewer Servicing & Section 7.0 Proposed Stormwater Management |
| <input type="checkbox"/> Analysis of available capacity in existing public infrastructure. | N/A |
| <input type="checkbox"/> A drawing showing the subject lands, its surroundings, the receiving watercourse, existing drainage patterns, and proposed drainage pattern. | Pre & Post-Development Plans |
| <input type="checkbox"/> Water quantity control objective (e.g. controlling post-development peak flows to pre-development level for storm events ranging from the 2 or 5-year event (dependent on the receiving sewer design) to 100-year return period); if other objectives are being applied, a rationale must be included with reference to hydrologic analyses of the potentially affected subwatersheds, taking into account long-term cumulative effects. | Section 6.0 Storm Sewer Servicing & Section 7.0 Proposed Stormwater Management |
| <input type="checkbox"/> Water Quality control objective (basic, normal or enhanced level of protection based on the sensitivities of the receiving watercourse) and storage requirements. | Section 6.0 Storm Sewer Servicing & Section 7.0 Proposed Stormwater Management |
| <input type="checkbox"/> Description of the stormwater management concept with facility locations and descriptions with references and supporting information. | Section 6.0 Storm Sewer Servicing & Section 7.0 Proposed Stormwater Management |
| <input type="checkbox"/> Set-back from private sewage disposal systems. | N/A |
| <input type="checkbox"/> Watercourse and hazard lands setbacks. | N/A |
| <input type="checkbox"/> Record of pre-consultation with the Ontario Ministry of Environment and the Conservation Authority that has jurisdiction on the affected watershed. | N/A |
| <input type="checkbox"/> Confirm consistency with sub-watershed and Master Servicing Study, if applicable study exists. | N/A |
| <input type="checkbox"/> Storage requirements (complete with calculations) and conveyance capacity for minor events (1:5-year return period) and major events (1:100-year return period). | Appendix G |

| | |
|---|--|
| <input type="checkbox"/> Identification of watercourses within the proposed development and how watercourses will be protected, or, if necessary, altered by the proposed development with applicable approvals. | Site Grading Plan (C101) |
| <input type="checkbox"/> Calculate pre-and post development peak flow rates including a description of existing site conditions and proposed impervious areas and drainage catchments in comparison to existing conditions. | Appendix G, Section 7.0 Proposed Stormwater Management |
| <input type="checkbox"/> Any proposed diversion of drainage catchment areas from one outlet to another. | Section 6.0 Storm Sewer Servicing & Section 7.0 Proposed Stormwater Management |
| <input type="checkbox"/> Proposed minor and major systems including locations and sizes of stormwater trunk sewers, and stormwater management facilities. | Section 6.0 Storm Sewer Servicing & Section 7.0 Proposed Stormwater Management |
| <input type="checkbox"/> If quantity control is not proposed, demonstration that downstream system has adequate capacity for the post-development flows up to and including the 100-year return period storm event. | N/A |
| <input type="checkbox"/> Identification of potential impacts to receiving watercourses | N/A |
| <input type="checkbox"/> Identification of municipal drains and related approval requirements. | N/A |
| <input type="checkbox"/> Descriptions of how the conveyance and storage capacity will be achieved for the development. | Section 6.0 Storm Sewer Servicing & Section 7.0 Proposed Stormwater Management |
| <input type="checkbox"/> 100-year flood levels and major flow routing to protect proposed development from flooding for establishing minimum building elevations (MBE) and overall grading. | Site Grading Plan (C101) |
| <input type="checkbox"/> Inclusion of hydraulic analysis including hydraulic grade line elevations. | N/A |

| | |
|--|--|
| <input type="checkbox"/> Description of approach to erosion and sediment control during construction for the protection of receiving watercourse or drainage corridors. | Section 8.0 Sediment & Erosion Control |
| <input type="checkbox"/> Identification of floodplains – proponent to obtain relevant floodplain information from the appropriate Conservation Authority. The proponent may be required to delineate floodplain elevations to the satisfaction of the Conservation Authority if such information is not available or if information does not match current conditions. | N/A |
| <input type="checkbox"/> Identification of fill constraints related to floodplain and geotechnical investigation. | N/A |

4.5 Approval and Permit Requirements: Checklist

The Servicing Study shall provide a list of applicable permits and regulatory approvals necessary for the proposed development as well as the relevant issues affecting each approval. The approval and permitting shall include but not be limited to the following:

| Criteria | Location (if applicable) |
|---|--------------------------|
| <input type="checkbox"/> Conservation Authority as the designated approval agency for modification of floodplain, potential impact on fish habitat, proposed works in or adjacent to a watercourse, cut/fill permits and Approval under Lakes and Rivers Improvement Act. The Conservation Authority is not the approval authority for the Lakes and Rivers Improvement Act. Where there are Conservation Authority regulations in place, approval under the Lakes and Rivers Improvement Act is not required, except in cases of dams as defined in the Act. | N/A |
| <input type="checkbox"/> Application for Certificate of Approval (CofA) under the Ontario Water Resources Act. | N/A |
| <input type="checkbox"/> Changes to Municipal Drains. | N/A |
| <input type="checkbox"/> Other permits (National Capital Commission, Parks Canada, Public Works and Government Services Canada, Ministry of Transportation etc.) | N/A |

4.6 Conclusion Checklist

| Criteria | Location (if applicable) |
|--|---|
| <input type="checkbox"/> Clearly stated conclusions and recommendations | Section 9.0 Summary Section 10.0 Recommendations |
| <input type="checkbox"/> Comments received from review agencies including the City of Ottawa and information on how the comments were addressed. Final sign-off from the responsible reviewing agency. | All are stamped |
| <input type="checkbox"/> All draft and final reports shall be signed and stamped by a professional Engineer registered in Ontario | All are stamped |