

SITE SERVICING & STORMWATER MANAGEMENT REPORT

3145 CONROY ROAD

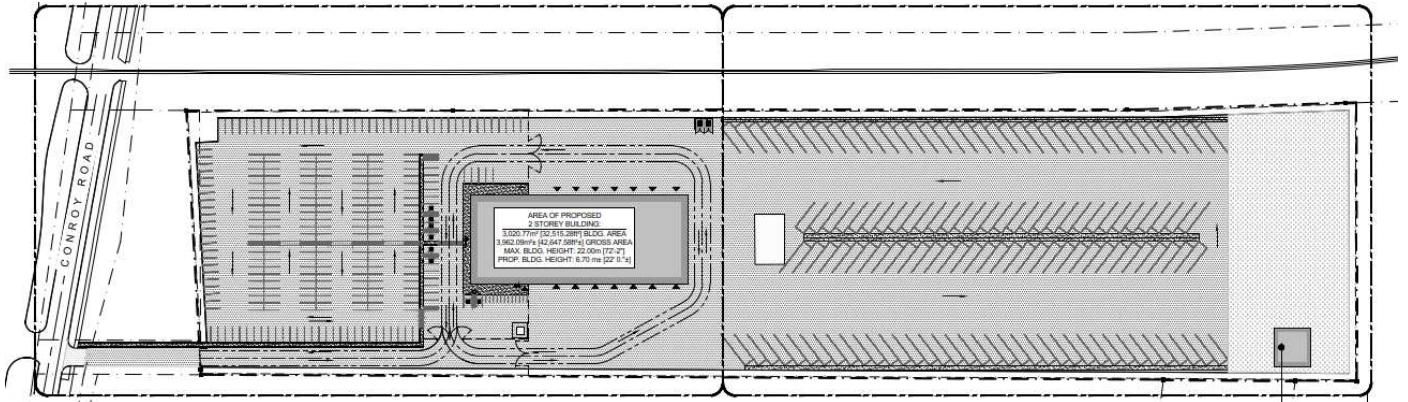

Project No.: CCO-25-1505

Prepared for:

WO MW Realty
180 Renfrew Drive, Suite 230
Markham, Ontario

Prepared by:

Egis Canada, Ltd.
750 Palladium Drive, Suite 310
Kanata, Ontario

2025/07/31

Revised 2026/03/12

Table of Content

1.0	PROJECT DESCRIPTION.....	1
1.1	<i>Purpose</i>	<i>1</i>
1.2	<i>Site Description</i>	<i>1</i>
1.3	<i>Existing Conditions and Infrastructure.....</i>	<i>2</i>
1.4	<i>Proposed Development and Statistics.....</i>	<i>2</i>
1.5	<i>Approvals.....</i>	<i>2</i>
2.0	BACKGROUND STUDIES, STANDARDS AND REFERENCES	2
2.1	<i>Background Studies</i>	<i>2</i>
2.2	<i>Applicable Guidelines and Standards.....</i>	<i>3</i>
3.0	PRE-CONSULTATION SUMMARY	3
4.0	WATERMAIN	4
4.1	<i>Existing Watermain.....</i>	<i>4</i>
4.2	<i>Proposed Watermain</i>	<i>4</i>
4.3	<i>Fire Flow and Hydrants</i>	<i>4</i>
5.0	SANITARY DESIGN.....	5
5.1	<i>Existing Sanitary Sewer.....</i>	<i>5</i>
5.2	<i>Proposed Sanitary Sewer</i>	<i>6</i>
6.0	STORM SEWER DESIGN.....	7
6.1	<i>Existing Storm Sewers</i>	<i>7</i>
6.2	<i>Proposed Storm Sewers</i>	<i>7</i>
7.0	PROPOSED STORMWATER MANAGEMENT	7
7.1	<i>Design Criteria and Methodology.....</i>	<i>7</i>
7.2	<i>Runoff Calculations.....</i>	<i>7</i>
7.3	<i>Pre-Development Drainage.....</i>	<i>8</i>
7.4	<i>Post-Development Drainage.....</i>	<i>8</i>

7.5	Quantity Control.....	9
7.6	Quality Control.....	9
8.0	SUMMARY	10
9.0	RECOMMENDATIONS	10
10.0	STATEMENT OF LIMITATIONS	11

APPENDIX A – LOCATION PLAN

APPENDIX B – BACKGROUND INFORMATION

APPENDIX C – WATER SERVICE CALCULATIONS

APPENDIX D – SANITARY SERVICE CALCULATIONS

APPENDIX E – PRE-DEVELOPMENT DRAINAGE PLAN

APPENDIX F – POST-DEVELOPMENT DRAINAGE PLAN

APPENDIX G – STORMWATER CALCULATIONS

APPENDIX H – CITY OF OTTAWA CHECKLIST

1.0 PROJECT DESCRIPTION

1.1 Purpose

Egis Canada Ltd. (Egis) has been retained by WO MW Realty Limited to prepare this Servicing & Stormwater Report for the proposed development at 3145 Conroy Road. This report will address the water, sanitary and storm sewer servicing for the development, ensuring that existing and available services will adequately service the proposed development. It will present a servicing design for the development in accordance with the recommendations and guidelines provided by the City of Ottawa, and the Rideau Valley Conservation Authority (RVCA) as required.

This report should be read in conjunction with the following drawings:

- C101 – Lot Grading, Drainage, and Erosion & Sediment Control Plan
- C102 – Site Servicing Plan
- PRE – Pre-Development Drainage Area Plan (Appendix E)
- POST – Post-Development Drainage Area Plan (Appendix F)

1.2 Site Description

The existing parcel is an undeveloped 4.86 ha property, shown in Figure 1. The majority of the site is vegetated but does have an existing entrance from Conroy Road complete with an old go-kart track and remnants of an outdoor mini-putt area. The site development is to be a 3,020 m² industrial building with associated parking. The site is zoned General Industrial, Subzone 3 (IG3).

See Site Location Plan in **Appendix A** for more details.



Figure 1: Site Location

1.3 Existing Conditions and Infrastructure

The existing site does not have water or sanitary servicing. Stormwater runoff currently flows toward Conroy Road via overland sheet flow and ditching, as well toward the east property line via overland flow, or is otherwise infiltrated on site.

Watermain and sewer mapping collected from the City of Ottawa's GIS information, indicate that the following services exist across the property frontages within adjacent municipal rights-of-ways (ROW):

- Conroy Road
 - 406 mm diameter ductile iron (DI) watermain
 - 2250 mm diameter concrete storm sewer
 - 300 mm diameter concrete storm sewer
- Johnston Road
 - 1200 mm diameter concrete sanitary sewer

1.4 Proposed Development and Statistics

The proposed development is to consist of a 3,020 m² warehouse building with truck and employee parking to be provided. The existing entrance off Conroy Road will remain to access the site. Further details are available in the site plan provided by Deimling Architecture.

1.5 Approvals

The proposed development is subject to the City of Ottawa site plan control process. Site plan control requires the City to review, provide concurrence, and approve the engineering design package.

An Environmental Compliance Approval (ECA) through the Ministry of the Environment, Conservation, and Parks (MECP) is anticipated to be required for the development due to the building potentially being considered "industrial" by the MECP. MECP approval would also be required for a sanitary main extension from Johnston Road down Conroy Road.

2.0 BACKGROUND STUDIES, STANDARDS AND REFERENCES

2.1 Background Studies

- *Conroy Road, As-built Plan and Profile Drawings – Watermain and Services (7369p&p04 & 05), 1987.*
- *Conroy Road, Record Drawings Plan and Profile (10313p&p19, 20.21), 2000.*
- *Southwood Subdivision, Grandpark Circle Plan and Profile Record Drawings (10937p&p2 & 3), 2001.*
- *Sketch showing Topographic Detail of 3145 Conroy Road, 2024.*
- *Proposed CNG Truck Parking and Yard Layout - Conceptual Site Plan, 2024.*

info.north-america@egis-group.com | www.egis-group.com

2.2 Applicable Guidelines and Standards

- Ottawa Sewer Design Guidelines, City of Ottawa, SDG002, October 2012. (Ottawa Sewer Guidelines)
 - Technical Bulletin ISTB-2014-01 City of Ottawa, February 2014. (ISTB-2014-01)
 - Technical Bulletin PIEDTB-2016-01 City of Ottawa, September 2016. (PIEDTB-2016-01)
 - Technical Bulletin ISTB-2018-01 City of Ottawa, January 2018. (ISTB-2018-01)
 - Technical Bulletin ISTB-2018-03 City of Ottawa, March 2018. (ISTB-2018-03)
 - Technical Bulletin ISTB-2019-01 City of Ottawa, January 2019. (ISTB-2019-01)
 - Technical Bulletin ISTB-2019-02 City of Ottawa, February 2019. (ISTB-2019-02)
- Ottawa Design Guidelines – Water Distribution City of Ottawa, July 2010. (Ottawa Water Guidelines)
 - Technical Bulletin ISD-2010-2 City of Ottawa, December 15, 2010. (ISD-2010-2)
 - Technical Bulletin ISDTB-2014-02 City of Ottawa, May 2014. (ISDTB-2014-02)
 - Technical Bulletin ISTB-2018-02 City of Ottawa, March 2018. (ISTB-2018-02)
- Stormwater Planning and Design Manual, Ministry of the Environment, March 2003. (MECP Stormwater Design Manual)
- Design Guidelines for Sewage Works, Ministry of the Environment, 2008. (MECP Sewer Design Guidelines)
- Water Supply for Public Fire Protection, Fire Underwriters Survey, 2020. (FUS Guidelines)
- Ontario Building Code (OBC)

3.0 PRE-CONSULTATION SUMMARY

A pre-consultation meeting was conducted on August 12, 2024, regarding the proposed site. Specific design parameters to be incorporated for the site include the following:

- There is no infrastructure currently available to direct sanitary flows. An extension from the 1200 mm Collector on Johnston Road is to run to the site along Conroy Road, or an easement is to be made through a City of Ottawa owned parcel (3179 Conroy Rd) and a privately owned parcel (2101 Johnston Rd) for a sanitary extension to be laid.
- Post-development storm flows (2-yr, 5-yr and 100-yr) must be controlled to the 5-year pre-development storm flows with the lower of the existing coefficient or maximum $C=0.5$ being used. Excess flows must be detained on site. Time of concentration cannot be less than 10 minutes.
- Quality control to be provided to achieve 80% total suspended solids removal.
- Water connection to the 406 mm watermain will be permitted, though not typically accepted. Further discussion is to occur.

Pre-consultation notes can be found in **Appendix B**.

4.0 WATERMAIN

4.1 Existing Watermain

There is an existing 406 mm watermain along Conroy Road.

4.2 Proposed Watermain

A new 200 mm diameter water service is proposed to service the site. The connection is to be made to the existing 406 mm diameter watermain within Conroy Road. The water service is designed to have a minimum of 2.4 m cover and will be insulated where required by City of Ottawa standards.

The Fire Underwriters Survey 2020 (FUS) method was utilized to determine the required fire flow for the site. The 'C' factor (type of construction) for the FUS calculation was determined to be 1.0 (ordinary construction). The building will also have a supervised sprinkler system. The total floor area ('A' value) for the FUS calculation was determined to be 3,811 m². The results of the calculations yielded a required fire flow of 8,000 L/min. A fire flow of 9,000 L/min was calculated using the OBC criteria. The detailed calculations for the FUS and OBC can be found in **Appendix C**.

The water demands for the proposed buildings have been calculated to adhere to the Ottawa Water Guidelines per Section 2.2 and can be found in **Appendix C**. The results have been summarized in Table 1.

Table 1: Water Demands

Design Parameter	Value
Site Area	4.86 ha
Industrial – Heavy	55,000 L/ha/day
Commercial	28,000 L/ha/day
Average Day Demand	0.17 L/s
Maximum Day Demand	0.25 L/s
Peak Hour Demand	0.45 L/s
OBC Fire Flow Requirements	150 L/s
FUS Fire Flow Requirements	133 L/s

4.3 Fire Flow and Hydrants

Boundary conditions for the site were requested and received from the city, dated August 20, 2024. The model assumed demands for the property as - Average Day = 0.14 L/s, Maximum Day = 0.21 L/s and Maximum Hourly = 0.26 L/s, and the fire flow to be 200 L/s, results are summarized in Table 2 below. These values differ from the final demands presented in Table 1, however, the boundary conditions were not impacted by the change – see

Appendix C for the Boundary Condition at 3145 Conroy Road provided by the City of Ottawa Infrastructure & Water Services Department.

Table 2: Boundary Conditions

Scenario	Total HGL (m)	Head Pressure* (kPa)	Head Pressure (psi)
Average Day (maximum HGL)	130.00	443.90	64.38
Maximum Day + Fire Flow	126.40	408.59	59.26
Peak Hour (minimum HGL)	125.10	395.83	57.41

The boundary conditions were used to ensure the normal operating pressure range is not less than 275 kPa (40 psi) or more than 552 kPa (80 psi). The resultant hydraulic grade line (HGL) shows that the minimum pressure limit is satisfied during the average day and peak hour scenario.

In addition to normal operations, the maximum day plus fire flow conditions were reviewed to ensure that there is sufficient fire flow available to meet the required 133 L/sec flow rate, while maintaining a minimum of 20 psi (140 kPa) within the City’s distribution system as per the Ottawa Water Guidelines per Section 2.2. The resulting HGL shows that the minimum pressure is satisfied during a fire scenario.

In addition to the review of the boundary conditions, the available fire flow based on hydrant spacing was analysed as per the City of Ottawa’s technical bulletin ISTB-2018-02 as per Section 2.2, Appendix I, Table 1. All existing and proposed municipal hydrants within 150 m clear distance to the nearest face of the building were used to find a combined available fire flow to support the site. Existing and proposed hydrants were assumed to be class AA. A total contribution of 5,700 L/min and 3,800 L/min was used for each hydrant within 75 m, and between 75 m and 150 m of the building, respectively. The results are summarized below in Table 3 below.

Table 3: Hydrant Spacing

Location	Assumed Colour/Class	Distance (m)	Fire Flow Contribution (L/min)
Conroy Road	Blue (class AA assumed)	145	3,800
Proposed On-site	Blue (class AA assumed)	50	5,700
Total (L/min)			9,500

Based on ISTB-2018-02, the existing hydrant on Conroy Road along with the proposed private hydrant can provide adequate fire protection to the proposed development (133 L/s = 8,000 L/min).

5.0 SANITARY DESIGN

5.1 Existing Sanitary Sewer

The site is located in an area not currently serviced by municipal sanitary sewers. The nearest sanitary sewer is a 1200 mm concrete sewer within Johnston Road.

5.2 Proposed Sanitary Sewer

A municipal sanitary sewer is proposed to be extended from the intersection of Johnston Road and Conroy Road, connecting to the existing 1200 mm diameter concrete sewer within Johnston Road. The new sewer will extend approximately 290 m north along Conroy Road to service the subject property.

A truck washing station is to be included in the building. Correspondence with the facility owner confirms that the proposed truck washing operations at 3145 Conroy Road will be conducted within an interior wash bay, using two pressure washers to accommodate approximately 30–40 truck washes per day. The facility is committed to compliance with the City’s Sewer Use By-law, including the installation and regular maintenance of oil/water and sand/grit interceptors, record retention for maintenance activities, and ensuring that all effluent discharge meets the specified quality limits for parameters such as biological oxygen demand (BOD), oil and grease, suspended solids, pH, and metals. Oversight of these practices will be managed by the Fleet team, with support from specialists/technicians for effluent testing as required. The increased demand (per Appendix 4 of the Ottawa Sewer Guidelines) has been accommodated in the sewer demand calculations and conform with design.

The peak design flows for the proposed buildings were calculated using criteria from the Ottawa Sewer Guidelines as per Section 2.2 and are summarized in Table 4. The proposed site development is expected to generate a sanitary flow of 3.68 L/s under peak wet weather conditions. See **Appendix D** for more details.

Table 4: Sanitary Design Criteria

Design Parameter	Value
Site Area	4.86 ha
Industrial – Heavy	55,000 L/ha/day
Institutional/Commercial Peaking Factor	5.5
Extraneous Flow Allowance	0.33 L/s/ha
Total Infiltration Flow	1.60 L/s
Peak Sewage Flow	2.32 L/s
Total Peak Wet Weather Flow	3.68 L/s

A single 150 mm diameter gravity sanitary service connection is proposed to tie into the new municipal sanitary sewer within Conroy Road. The private sanitary system will include three maintenance holes located on-site. One of these will serve as a monitoring maintenance hole for sampling and flow observation, in accordance with the Ottawa Sewer Guidelines (Clause 4.4.4.7) and the City of Ottawa Sewer-Use By-Law 2003-514 (Section 14) as per Section 2.2.

The proposed 150 mm gravity sanitary sewer will be designed to achieve a minimum full-flow (cleansing) velocity of 0.6 m/s and a maximum full-flow velocity of 3.0 m/s. Design parameters for the site include an infiltration rate of 0.33 L/s/ha, consistent with City of Ottawa requirements.

6.0 STORM SEWER DESIGN

6.1 Existing Storm Sewers

There are existing 300 mm and 2,250 mm storm sewers adjacent to the property on Conroy Road. Stormwater runoff from the site is currently draining toward the west of the site via overland flow and ditching and to the east of the site via overland flow.

Refer to **Appendix E** for the pre-development drainage plan.

6.2 Proposed Storm Sewers

Based on the pre-consultation meeting, all runoff is to be directed to Conroy Road. This will be achieved via storm pipes, catch basins, and overland flow. The site's stormwater system will connect to the 2,250 mm diameter concrete sewer in Conroy Road. An outlet pipe with an orifice plate is specified with surface storage for quantity control. An approved oil-grit separator is proposed and has been sized to provide quality control.

Refer to **Appendix F** for the post-development drainage plan.

7.0 PROPOSED STORMWATER MANAGEMENT

7.1 Design Criteria and Methodology

Stormwater management for the proposed development will need to consist of storm structures and a network of pipes to direct storm runoff towards the proposed storm sewer within Conroy Road. The quantitative properties of the storm runoff for both the pre- and post-development flows are further detailed below.

In summary, the following design criteria has been employed in development the stormwater management design for the site:

Quantity Control

- Post-development flows are to be restricted to no greater than the Pre-Development Runoff for the 5-year storm event (263.85 L/s).

Quality Control

- 80% removal of Total Suspended Solids (TSS).

7.2 Runoff Calculations

Runoff calculations presented in this report are derived using the Rational Method, given as:

$$Q = 2.78CIA \text{ (L/s)}$$

Where: C = Runoff coefficient

info.north-america@egis-group.com | www.egis-group.com

I = Rainfall intensity in mm/hr (City of Ottawa IDF curves)

A = Drainage area in ha

It is recognized that the Rational Method tends to overestimate runoff rates. As a result, the conservative calculation of runoff ensures that any SWM facility sized using this method is expected to function as intended.

The following coefficients were used to develop an average C for each area, summarized in Table 5:

Table 5: Runoff Coefficients

Land Cover	C
Roofs/Concrete/Asphalt	0.90
Gravel	0.60
Undeveloped/Grass	0.20

As per the Ottawa Sewer Guidelines, the 5-year balanced C-value must be increased by 25% for a 100-year storm event to a maximum of 1.0.

7.3 Pre-Development Drainage

The existing site drainage limits are demonstrated on the Pre-Development Drainage Area Plan. A summary of the pre-development runoff calculations can be found in Table 6.

Table 6: Pre-Development Runoff Summary

Drainage Area	Area (ha)	Runoff Coefficient (2-Year)	Runoff Coefficient (5-Year)	Runoff Coefficient (100-Year)	2-Year Peak Flow (L/s)	5-Year Peak Flow (L/s)	100-Year Peak Flow (L/s)
A1	4.86	0.28	0.28	0.33	193.76	263.85	541.88

See the SWM Calculations in **Appendix G**.

7.4 Post-Development Drainage

The proposed site drainage limits are demonstrated on the Post-Development Drainage Area Plan found in **Appendix F** of this report. A summary of the post-development runoff calculations for the site is shown in Table 7.

Table 7: Post-Development Runoff Summary

Drainage Area	Unrestricted Flow (L/s)			Restricted Flow (L/s)			Storage Required m ³		
	2-Year	5-Year	100-Year	2-Year	5-Year	100-Year	2-Year	5-Year	100-Year
B1	190.49	259.40	496.11	32.60	33.40	35.50	118.33	183.9	432.0
B2	564.67	768.92	1478.51	138.00	141.70	143.10	289.59	460.9	1,160.5
B3	28.18	38.37	82.19	28.18	38.37	82.19			
Total	783.34	1066.69	2056.81	198.78	213.47	260.79	407.92	644.86	1592.53

See **Appendix G** for detailed calculations.

7.5 Quantity Control

The total post-development runoff for this site has been restricted to match the required release rate of 263.85 L/s, (5-year release rate with a C value of less than 0.5 as per the pre-consultation meeting).

Area B1 has a restricted release rate of 32.6, 33.4 and 35.5 L/s for 2-, 5- and 100-year storm events, respectively. The stormwater in this area is conveyed via overland flow, catch basins, and pipes and uses surface ponding above the proposed catch basins and a retention area on the west property line to restrict the release rate. The release rate from the site is restricted via a 95 mm IPEX orifice inlet control device (ICD) located in a private catch basin/maintenance hole. The volume of stormwater to be retained on site is approximately 124.3, 189.0 and 435.6 m³ for the 2-year, 5-year and 100-year storm events, respectively.

Area B2 has a restricted release rate of 138.0, 141.7 and 143.1 L/s for 2-, 5- and 100-year storm events, respectively. The stormwater in this area is conveyed via overland flow, catch basins, pipes and uses surface ponding above the proposed catch basins to restrict the release rate. The release rate from the site is restricted via a 175 mm IPEX orifice ICD located in a private catch basin/maintenance hole. The volume of stormwater to be retained on site is approximately 296.5, 463.1 and 1206.6 m³ for the 2-year, 5-year and 100-year storm events, respectively.

Area B3 is to be released unrestricted to the property lines, maintain existing flow patterns at a reduced rate.

See **Appendix G** for SWM calculations.

7.6 Quality Control

The 80% TSS removal as required is achieved as **Area B3** runoff is only from the landscape areas so this water does not interact with areas that would require TSS removal. Therefore, quality control via an Oil and Grit Separator (OGS) is to be provided to **Areas B1** and **B2** which collects over 90% of the stormwater onsite. The OGS unit shall be placed downstream of the parking area storm structures and sewers to provide the required stormwater quality treatment for the site runoff before discharging to the municipal sewer Conroy Road. The OGS was sized to achieve a TSS removal of 80% or greater under the Fine Particle Size Distribution (PSD) criteria. Also, due to the use of the site it has been identified that an enhanced level of oil capture is required. The result

info.north-america@egis-group.com | www.egis-group.com

of the sizing generated a Stormceptor EFO10, providing 80% under fine PSD. An approved equivalent will be acceptable for the site as well. Detailed OGS sizing is provided within **Appendix G**.

The development of this lot will employ Best Management Practices (BMPs) wherever possible. The intent of implementing stormwater BMPs is to ensure that stormwater quality and quantity concerns are addressed at all stages of development. Lot level BMPs typically include temporary retention of the parking lot runoff and minimizing ground slopes. Some of these BMPs cannot be provided for this site due to site constraints and development requirements.

8.0 SUMMARY

- A 3,020 m² office and garage development with associated parking is proposed at 3145 Conroy Road is proposed.
- A new 200 mm diameter water service is to service the site, extending from the existing 400 mm watermain within Conroy Road. A 200 mm lateral will be installed for the private hydrant on site.
- A new sanitary sewer is to be constructed on Conroy Road; this will provide the outlet for the proposed development along with the associated proposed 150 mm diameter laterals.
- Stormwater is to be collected via a system of catch basins and pipes from 300 mm to 750 mm diameter.
- Post-development stormwater flows for the 100-year storm are to be restricted to be no greater than 263.85 L/s. Storage to occur by surface ponding and release rate to be controlled by a 95 mm and 175 mm orifice ICD.
- Quality control to be provided by the proposed OGS unit to achieve 80% TSS removal.

9.0 RECOMMENDATIONS

Based on the information presented in this report, we recommend that City of Ottawa approve this Servicing and Stormwater Management Report in support of the proposed 3145 Conroy Road.

This report is respectfully being submitted for approval.

Regards,

EGIS CANADA LTD.



Jessica Burden, P. Eng
Project Engineer, Land Development
613-266-5779

A handwritten signature in black ink, appearing to read "Robbie Pickard".

Robbie Pickard, E.I.T.
Engineering Intern, Land Development
613-808-3427

10.0 STATEMENT OF LIMITATIONS

This report was produced for the exclusive use of WO MW Realty Limited. The purpose of the report is to assess the existing stormwater management system and provide recommendations and designs for the post-construction scenario that are in compliance with the guidelines and standards from the Ministry of the Environment, Conservation and Parks, City of Ottawa and local approval agencies. Egis Canada reviewed the site information and background documents listed in Section 2.0 of this report. While the previous data was reviewed by Egis Canada and site visits were performed, no field verification/measures of any information were conducted.

Any use of this review by a third party, or any reliance on decisions made based on it, without a reliance report is the responsibility of such third parties. Egis Canada accepts no responsibility for damages, if any, suffered by any third party as a result of decisions or actions made based on this review.

The findings, conclusions and/or recommendations of this report are only valid as of the date of this report. No assurance is made regarding any changes in conditions subsequent to this date. If additional information is discovered or becomes available at a future date, Egis Canada should be requested to re-evaluate the conclusions presented in this report, and provide amendments, if required.

APPENDIX A
LOCATION PLAN



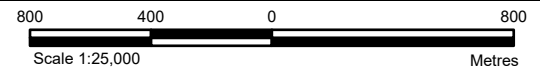
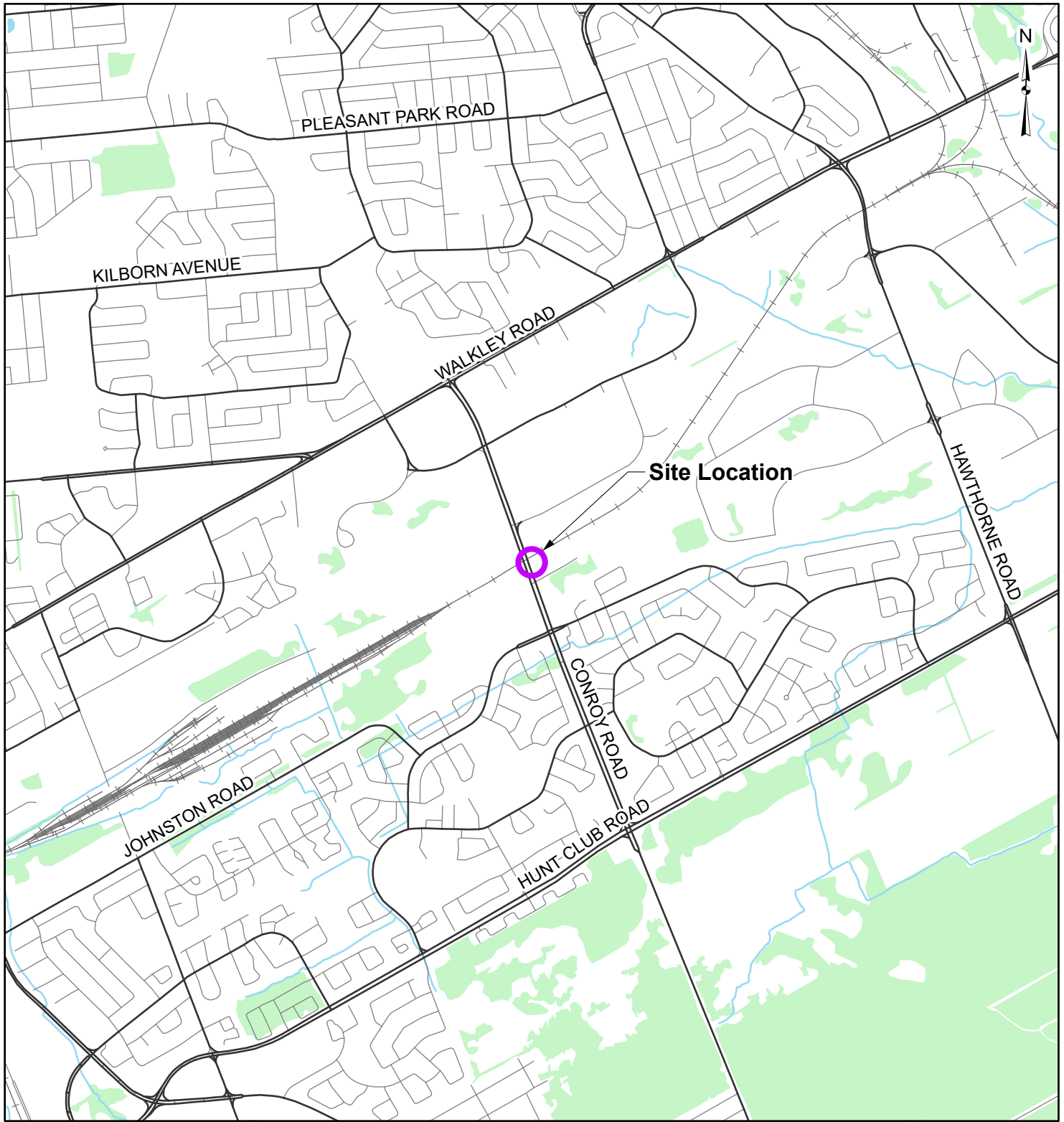

LEGEND

- Site Location
- Local Road
- Major Road
- Railroad
- Watercourse
- Waterbody
- Wooded Area

REFERENCE

GIS data provided by the Ontario Ministry of Natural Resources and Forestry, 2025.

CLIENT:	MILLER WASTE SYSTEMS 112 BALES DRIVE EAST, EAST GWILLIMBURY, ON		
PROJECT:	3145 CONROY ROAD		
TITLE:	LOCATION PLAN		
 <small>750 Palladium Dr, Suite 310, Kanata, ON K2V 1C7 Tel: 613-836-2184 Fax: 613-836-3742</small>	PROJECT NO:	CO-25-1505	FIGURE:
	Date	Jul., 28, 2025	00
	GIS	CZ	
	Checked By	RP	

C:\Users\zandell\EGIS Group\GIS - Documents\Projects\2025\CO-25-1505\3145 Conroy\arcx\Key\Map/LandDevelopment\CO-25-1505_Key Plan.aprx

APPENDIX B
BACKGROUND INFORMATION



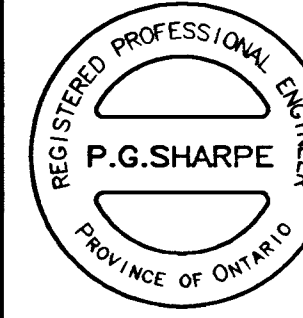

DILCAN ENGINEERS PLANNERS

NO.	REVISIONS	BY	DATE
1	DEP. CURBS @ JOHNSTON	DAH	07/98
2	MEDIAN O/S @ R.WY.	DAH	07/98
3	MH/CB/DI TABLES	DAH	07/98
4	SERVICES AT JOHNSTON	DAH	07/98
5	REC PATH & GRADING AT CN TRACK NORTH	PGS	08/98
6	DROP PIPE AT EXIST. MH	DAH	08/98
7	THUNDERBIRD-LT TURN LANE	DAH	06/99

Ottawa-Carleton

CONROY ROAD
HUNT CLUB ROAD TO WALKLEY ROAD

GRADING AND DRAINAGE
STA 51+050 TO STA 51+350

J. MILLER, P.ENG. W. BENNETT, P.ENG.
Director, Engineering Division Manager, Transportation Projects

DWG. NO. R-3010-20

SHEET 020 OF ---

CONTRACT NO. 98-505

Date: MAY, 1998

HORIZONTAL 1:20
VERTICAL 1:5

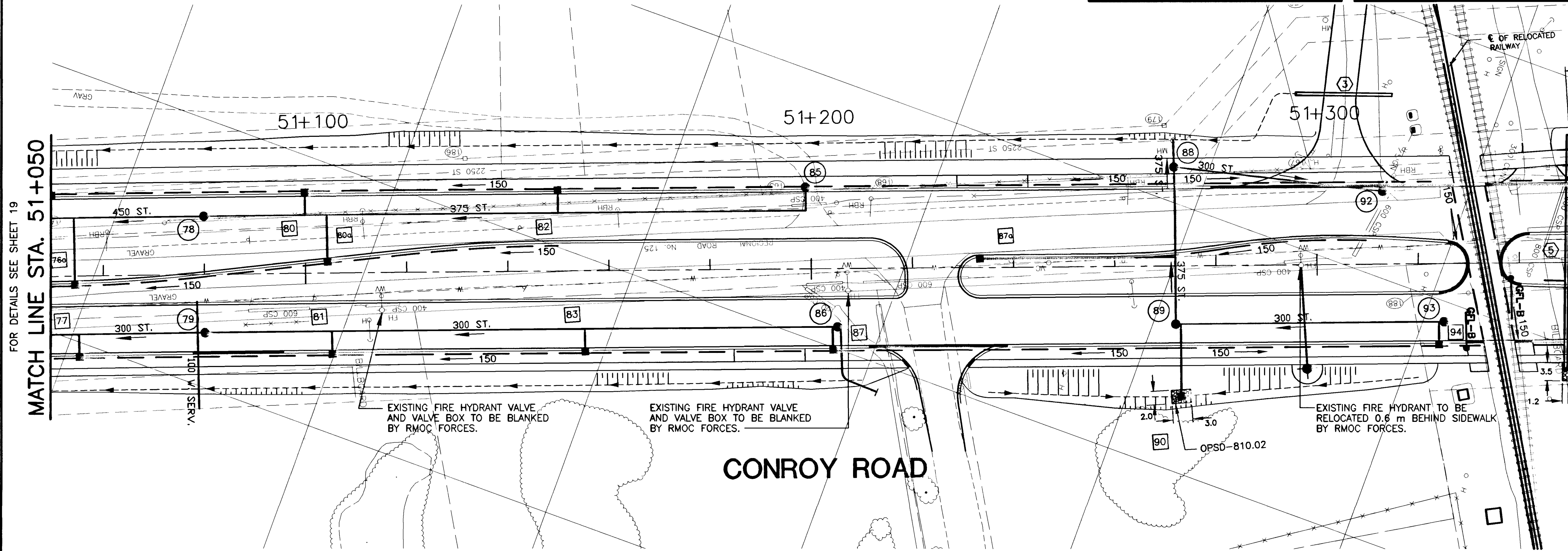

MANHOLES, CATCHBASINS AND DITCH INLET DATA						
No.	STATION	OFFSET (m)	TYPE OF STRUCTURE STD. No.	NEW GRATE STD. No.	ELEVATION	
					TOP OF GRATE	LOW INVERT
76a	51+055	0.96 R	705.010	J-3.4	83.21	81.46
77	51+055	15.25 R	705.010	J-3.4	83.03	81.28
78	51+080	11.50 L	701.010	J-3.10	83.40	81.29
79	51+080	11.50 R	701.010	J-3.10	83.35	81.44
80	51+100	15.25 L	705.010	J-3.4	83.51	81.76
80a	51+105	2.93 L	705.010	J-3.4	83.71	81.96
81	51+105	15.25 R	705.010	J-3.4	83.53	81.78
82	51+150	15.25 L	705.010	J-3.4	83.98	82.23
83	51+155	15.25 R	705.010	J-3.4	84.03	82.28
84	51+199	15.25 L	705.010	J-3.4	84.47	82.72
85	51+200	11.50 L	701.010	J-3.10	84.55	82.57
86	51+205	15.25 R	701.010	J-3.10	84.60	82.69
87	51+204	15.25 R	705.010	J-3.4	84.52	82.77
87a	51+233.3	2.50 R	705.010	J-3.4	84.91	83.16
88	51+272	19.50 L	701.010	J-3.10	85.01	82.51
89	51+272	11.50 R	701.010	J-3.10	85.01	82.62
90	51+273	25.84 R	705.030	403.01	83.35	82.84
91	51+314	14.95 L	705.010	400.02	84.87	83.12
92	51+315	11.50 L	701.010	J-3.10	84.89	82.91
93	51+325	11.50 R	701.010	J-3.10	84.82	82.91
94	51+324	15.25 R	705.010	J-3.4	84.76	83.01

* Offsets for Curb Inlets are to Face of Curb.
** Elev. for Curb Inlet Covers are Finished Asphalt at Grate.

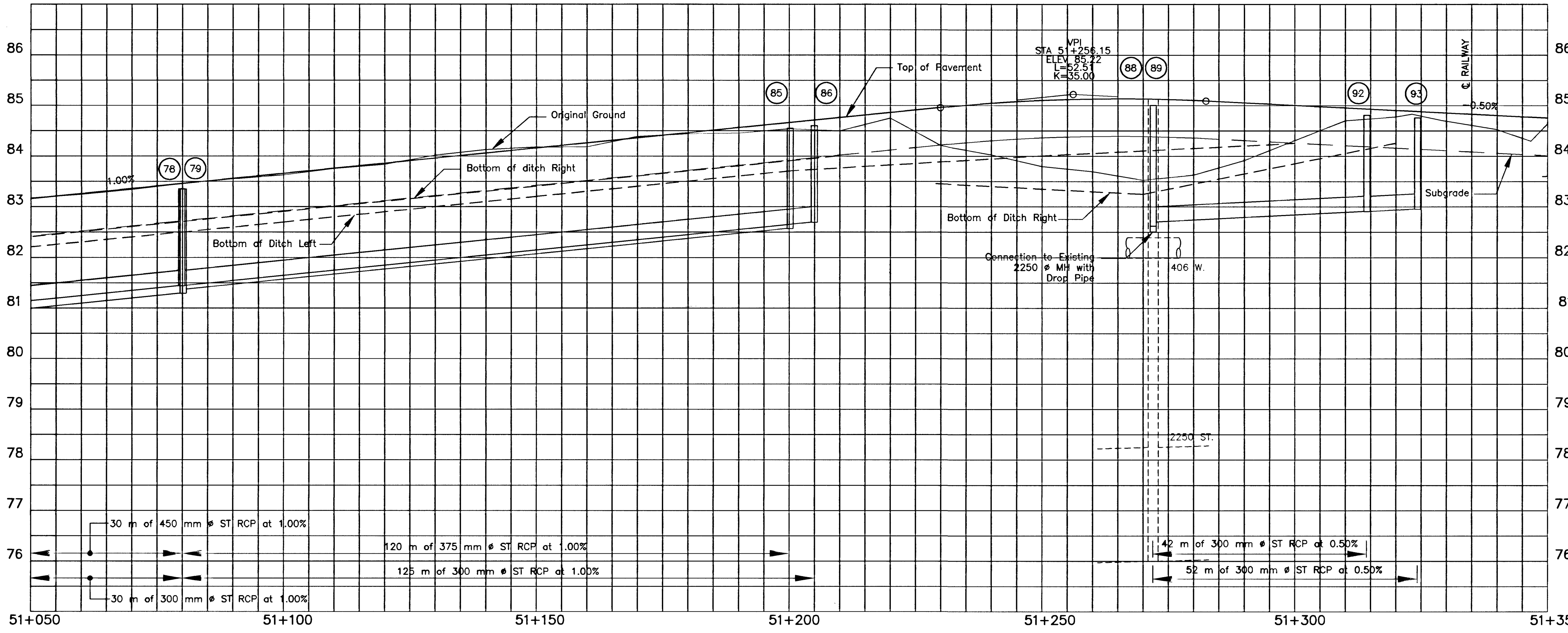

STORM SEWER DATA						
LOCATION	DIA. SIZE (mm)	CLASS OF PIPE	LENGTH (m)	INVERT ELEVATION		
				UPSTREAM	DOWNSTREAM	
MH 85 - MH 78	375	100 D	120	82.57	81.37	
MH 86 - MH 79	300	100 D	125	82.69	81.44	
MH 92 - MH 88	300	100 D	44.5	82.91	82.70	
MH 93 - MH 89	300	100 D	48	82.96	82.70	
MH 89 - MH 88	375	100 D	31	82.62	82.51	
MH 88 - EXIST.	375	100 D	4.6	82.51	82.44	
76a - PIPE	250	3 ES	13	81.46	-	
77 - PIPE	250	3 ES	4	81.28	-	
80 - PIPE	250	3 ES	3	81.76	-	
80a - PIPE	250	3 ES	9	81.96	-	
81 - PIPE	250	3 ES	4	81.78	-	
82 - PIPE	250	3 ES	2	82.23	-	
83 - PIPE	250	3 ES	4	82.28	-	
84 - PIPE	250	3 ES	4	82.72	Deleted	
87 - PIPE	250	3 ES	4	82.77	-	
87a - PIPE	250	3 ES	39	83.16	-	
90 - PIPE	300	100 D	14	82.84	-	
91 - PIPE	250	3 ES	3	83.12	Deleted	
94 - PIPE	250	3 ES	4	-	-	
MH86 - ThunderBird	250	100 D	19.4	-	-	

10313



August 12, 2024

Rachel MacKnight
Parsons Inc.
Via email: Rachel.macknight@parsons.com

**Subject: Pre-Consultation: Meeting Feedback
Proposed Site Plan Control Application – 3145 Conroy Road**

Please find below information regarding next steps as well as consolidated comments from the above-noted pre-consultation meeting held on August 6, 2024.

Pre-Consultation Preliminary Assessment

1 <input type="checkbox"/>	2 <input type="checkbox"/>	3 <input type="checkbox"/>	4 <input checked="" type="checkbox"/>	5 <input type="checkbox"/>
----------------------------	----------------------------	----------------------------	---------------------------------------	----------------------------

One (1) indicates that considerable major revisions are required while five (5) suggests that the proposal appears to meet the City’s key land use policies and guidelines. This assessment is purely advisory and does not consider technical aspects of the proposal or in any way guarantee application approval.

Next Steps

1. A review of the proposal and materials submitted for the above-noted pre-consultation has been undertaken. Pre-consultations are no longer mandatory with the royal assent of Bill 185; therefore, the applicant may proceed directly to the formal application stage, or they may complete another voluntary pre-consultation. In either case, please submit the required application and the necessary studies and/or plans to planningcirculations@ottawa.ca.
2. In your subsequent pre-consultation submission, please ensure that all comments or issues detailed herein are addressed. A detailed cover letter stating how each issue has been addressed must be included with the submission materials. Please coordinate the numbering of your responses within the cover letter with the comment numbers herein.

Supporting Information and Material Requirements

1. The attached **Study and Plan Identification List** outlines the information and material that has been identified, during this phase of pre-consultation, as either required (R) or advised (A) as part of a future complete application submission.
 - a. The required plans and studies must meet the City’s Terms of Reference (ToR) and/or Guidelines, as available on Ottawa.ca. These ToR and Guidelines outline

the specific requirements that must be met for each plan or study to be deemed adequate.

Consultation with Technical Agencies

1. You are encouraged to consult with technical agencies early in the development process and throughout the development of your project concept. A list of technical agencies and their contact information is enclosed.

Planning – Tess Peterman

Comments:

1. The site is designated Industrial and Logistics in the Outer Urban Transect. The proposed development aligns with the policies for Industrial and Logistics in the Official Plan.
2. The site is zoned General Industrial subzone 3 (IG3[1751]). The purpose of this zone is to permit a wide range of low to moderate impact, light industrial uses. A storage yard is a permitted use in this zone (please review the definition to confirm we have selected the correct use for your site as this will establish the parking rates).
 - a. The following link can be used to apply for a Zoning Information Letter for the CNG Compressor onsite.
 - i. [Zoning designation letter with list of permitted uses | City of Ottawa](#)
3. The property abuts the Walkley Rail Corridor which is a protected transportation corridor on Schedule C2 of the Official Plan. The site is within the 300-metre buffer for both rail yard and rail corridor. We strongly encourage the applicant to consult with CN (the carrier) early in the development process.
 - a. Staff have no concerns with providing parking within the 15 metre setback required in the FCM-RAC Guidelines as long as the other FCM-RAC Guidelines and the City's land use planning policies and zoning provisions are met.
4. A Land Use Compatibility Study is required as part of the formal submission that demonstrates that there is no problem between the proposed development and the nearby residential neighbourhood (i.e., D-6 Guidelines Assessment).
5. Zoning provisions to make note of:
 - a. *Section 59 – Frontage on a Public Street* requires a lot slated for development to abut a public street for a distance of at least 3 metres. The site does not have any frontage onto a public street therefore relief will need to be sought from this provision through a minor variance.

- b. Bicycle parking will be required as per *Section 111 – Bicycle Parking Space Rates and Provisions*. Please show bicycle parking on the site plan. It must be provided in a convenient location for access to main entrances or well-used areas.
6. Preliminary site plan comments:
 - a. Please indicate the gross floor area, floor space index, lot coverage, and building height in the tables on the site plan.
7. In addition to a CLI ECA (see comment #17 in the engineering section), a Waste ECA may be required.
 - a. Based on the definition of a “Waste Management System” in the *Environmental Protection Act* the proposed development may require an MECP Environmental Compliance Approval (ECA).

Please contact Tess Peterman, Planner I, for questions related to planning policy and the application process.

Urban Design – Molly Smith

Submission Requirements:

8. Urban Design Brief is required. Please see attached customized Terms of Reference to guide the preparation.
9. Additional drawings and studies are required as shown on the SPIL. Please follow the terms of references ([Planning application submission information and materials | City of Ottawa](#)) to prepare these drawings and studies. These include:
 - a. Design Brief
 - b. Site Plan
 - c. Landscape Plan
 - d. Elevations

Comments:

Applicants are to provide a response to these comments in the Design Brief.

10. Please provide clear, direct, and safe pedestrian pathways from building entrances to Conroy Road. There are several bus stops in the area and given the truck movement on site, effort should be given to move pedestrians from Conroy, the parking area and to building entrances safely and orderly.

11. Given the vast amount of paved surface area proposed, more opportunities for tree planting and permeable landscaping areas should be provided (native plantings preferred). Please focus on tree planting and landscaping around the parking area in vision to Conroy Road not only for screening purposes but also to increase the water permeability and ecological factors on site.

Please contact Molly Smith, Planner II, for any questions the applicant team may have.

Engineering – Bruce Bramah

Comments:

12. The Stormwater Management Criteria, for the subject site, is to be based on the following:
 - a. Application of the IDF information derived from the Meteorological Services of Canada rainfall data, taken from the MacDonald Cartier Airport, collected 1966 to 1997.
 - b. For separated sewer systems built up until 2016, the design of the storm sewers were based on a 5-year storm; storm systems after such time are, generally, based on a 2-year level-of-service.
 - c. In separated areas, the pre-development runoff shall be the lower of the existing coefficient or a maximum equivalent 'C' of 0.5, whichever is less (§ 8.3.7.3).
 - d. A calculated time of concentration (cannot be less than 10 minutes).
 - e. Flows to the storm sewer in excess of the 5-year storm release rate, up to and including the 100-year storm event, must be detained on site.
 - f. Storm sewer outlets should not be submerged.
 - g. Quality control (80% TSS removal) will be required.
13. Deep Services (Storm, Sanitary and/or Water Supply)
 - a. Services should ideally be grouped in a common trench to minimize the number of road cuts.
 - b. Connections to trunk sewers and easement sewers are typically not permitted but can be discussed further depending on elevations for the proposed site.
 - c. A monitoring maintenance hole will be required and should be located in an accessible location on private property near the property line (ie. Not in a parking area).

- d. Sewer connections to be made above the springline of the sewermain as per:
 - i. Std Dwg S11.1 for flexible main sewers – connections made using approved tee or wye fittings.
 - ii. Std Dwg S11 (For rigid main sewers) – lateral must be less than 50% the diameter of the sewermain,
 - iii. Std Dwg S11.2 (for rigid main sewers using bell end insert method) – for larger diameter laterals where manufactured inserts are not available; lateral must be less than 50% the diameter of the sewermain,
 - iv. Connections to manholes permitted when the connection is to rigid main sewers where the lateral exceeds 50% the diameter of the sewermain. – Connect obvert to obvert with the outlet pipe unless pipes are a similar size.

14. Water

- a. Backbone watermain connections are not typically permitted. Connection to the 406mm backbone watermain on Conroy road will be accepted with further discussions once you submit the boundary conditions.
- b. Water Boundary condition requests must include the location of the service (map or plan with connection location(s) indicated) and the expected loads required by the proposed development, including calculations. Please provide the following information:
 - i. Location of service
 - ii. Type of development
 - iii. The amount of fire flow required (per OBC or FUS).
 - iv. Average daily demand: ___ l/s.
 - v. Maximum daily demand: ___ l/s.
 - vi. Maximum hourly daily demand: ___ l/s.

15. There is not currently any public sanitary sewer fronting 3145 Conroy Rd. A sanitary sewer extension will be required through the Site Plan Application. Coordination with the Enbridge NG upgrades along Conroy Rd for this development is recommended to reduce road cuts and traffic management in the area.

- a. Option 1: Sanitary extension from the 1200mm collector on Johnston Rd to 3145 Conroy Rd.
 - b. Option 2: Sanitary extension through a future easement of the City of Ottawa owned parcel at 3179 Conroy Rd and the privately owned 2101 Johnston Rd connecting to the 1200mm collector on Johnston Rd.
16. Conroy Rd currently has 3 capital construction projects planned in 2024 within the frontage of 3145 Conroy. These capital work projects include asphalt resurfacing, MUP resurfacing and watermain cathodic protection. A road cut moratorium will be in place for 3 years once resurfaced. Further discussion with the IPM and our ROW group is recommended prior to submission.
17. An MECP Environmental Compliance Approval [**Industrial Sewage**] may be required for the proposed development. A sanitary sewer extension would fall within the new CLI ECA process. A Ministry contact has been provided below to coordinate the ECA requirements. Please include all correspondence in the submission package and copy the IPM.
- a. Shannon Hamilton-Browne at (613) 521-3450 or Shannon.Hamilton-Browne@ontario.ca

Feel free to contact Bruce Bramah, Project Manager, for follow-up questions.

Noise – Rochelle Fortier-Lesage

Comments:

18. Noise Study is required to assess the noise impact of the proposed sources of noise from the development onto the surrounding residential area to ensure the noise levels do not exceed allowable limits specified in the Environmental Noise Control Guidelines.

Feel free to contact Rochelle Fortier-Lesage (rochelle.fortier@ottawa.ca), Transportation Project Manager, for follow-up questions.

Transportation – Rochelle Fortier-Lesage

Comments:

19. Follow Transportation Impact Assessment Guidelines:
 - a. A Transportation Impact Assessment is required. Please submit the Scoping report to rochelle.fortier@ottawa.ca at your earliest convenience. The applicant is responsible to submit the Scoping Report and must allow for a 14-day circulation period and sign-off prior to the Strategy Report submission.

- b. The Strategy Report must be submitted for review at the latest with the formal submission package. The applicant is still encouraged to submit the Strategy Report to the TMP before submission of the Phase 3 pre-con or formal submission package and allow for a 14-day circulation period.
 - c. If an RMA is required to support the proposed development, the functional plan and/or RMA plans must be submitted with the formal submission to deem complete. Request base mapping asap if RMA is required. Contact [Engineering Services](#).
20. Ensure that the development proposal complies with the Right-of-Way protection requirements - See [Schedule C16 of the Official Plan](#). Any requests for exceptions to ROW protection requirements must be discussed with Transportation Planning and concurrence provided by Transportation Planning management.
21. Closure of the median on Conroy Road may be required for safety. This would require a Roadway Modification Approval (RMA). Alternatively, turn restrictions during peak hours could be considered. Include a review of the access in the TIA Scoping report.
22. Clear throat requirements for industrial (>45,000m²) on an arterial is 60m. Ensure this length is provided.
23. The City of Ottawa completed an EA study in 1997 for widening of Conroy Road between Hunt Club Road and Walkley Road. The EA Study also investigated options for grade-separation of the Walkley Rail Corridor and recommended a below-grade (under-pass) crossing of Conroy Road as a preferred solution. The development plan for 3145 Conroy Road will be required to continue providing access as far south as possible in order to future proof for this project should the City wish to pursue grade-separation at some point in the future.
24. Nearby [planned construction and infrastructure projects](#) include resurfacing and Multi-Use Pathway renewal on Conroy Road (planned this year)
25. Please consider using the [City's Accessibility Design Standards](#), which provide a summary of AODA requirements.
26. Provide sidewalk along one side of site entrance, linking to the existing sidewalk along Conroy Road. Sidewalk is to be continuous across access as per City Specification 7.1.
27. On site plan:
- a. Ensure site accesses meet the [City's Private Approach Bylaw](#) and all driveways/aisles meet the requirements outlined in [Section 107 of the Zoning By-law](#).

- b. Show all details of the roads abutting the site; include such items as pavement markings, accesses and/or sidewalks.
- c. Turning movement diagrams required for all accesses showing the largest vehicle to access/egress the site.
- d. Turning movement diagrams required for internal movements (loading areas, garbage).
- e. Show all curb radii measurements; ensure that all curb radii are reduced as much as possible and fall within TAC guidelines (Figure 8.5.1).
- f. Show dimensions for site elements (i.e. lane/aisle widths, access width and throat length, parking stalls, sidewalks, pedestrian pathways, etc.)
- g. Grey out any area that will not be impacted by this application.

Feel free to contact Rochelle Fortier-Lesage (rochelle.fortier@ottawa.ca),
Transportation Project Manager, for follow-up questions.

Environment – Mark Elliott

Comments:

28. The primary concern for this application, from an environmental perspective, is the possible presence of wetlands on the adjacent city-owned property to the south. Wetlands are subject to a 30m setback per the City's policies (Official Plan section 4.9.3). The wetlands currently mapped are quite close to the boundary between the two sites and, if present, would impose a roughly 25m no-touch setback along the southern boundary of this property.

However, it is possible that the mapping is out of date or inaccurate. If the applicant wishes to pursue the proposed design, then an EIS would need to be completed that addresses this issue. The EIS would need to include either a wetland delineation survey or a wetland evaluation survey.

The delineation survey would determine where the edge of the wetlands is and where the attendant setback would be. If the setbacks do not extend to the applicant's site, then a delineation survey would be sufficient.

If the wetland setback still interferes with the proposed development, then the applicant could apply for a reduced setback per the provisions of Official Plan policy 4.9.3.6, policy f. This would require a wetland evaluation survey, conducted by a licensed evaluator, to determine a) that the wetland is not provincially significant and b) what an appropriate setback would be.

As the site to the south is owned by the City, access can be negotiated.

29. The only species-at-risk (SAR) animal likely present on site is the Bobolink, a field bird. The EIS should investigate the possibility of their presence on site. Mitigation measures from the City's [Protocol for the Protection of Wildlife During Construction](#) should be incorporated into the EIS and development plan to protect any potential SARs, as well as any other wildlife on site.
30. There is also the potential for species-at-risk trees, both the Butternut and Black Ash, to be present. The Tree Conservation Report (as required by forestry – see below) should be sufficient to address the issues. Note that the presence or absence of these trees should be mentioned specifically in that report.
31. Technically, the watercourse on the northern edge of the railway tracks would impose a minor setback on the northern edge of the property. However, given the degree of disturbance imposed by the intervening railway, the need for this setback can be waived; there is little to no chance of any (additional) negative impact to this watercourse by the proposed development.
32. There is a substantial amount of impermeable surface being proposed for this development. Additional tree planting to help offset this, as well as to reduce the impacts of climate change and the urban heat island effect, should be incorporated wherever possible. Please note that the City prefers that all plantings be of native and non-invasive species.

The applicant is encouraged to reduce the amount of paving present if possible.

Feel free to contact Mark Elliott, Environmental Planner, for follow-up questions.

Forestry – Hayley Murray

Comments:

33. A tree removal permit is required prior to any tree removal on site. Please contact the Planning Forester, hayley.murray@ottawa.ca, for more information on the process. Please note the implications of the Migratory Bird Convention Act on the timing of tree removal.
34. A Tree Conservation Report and Landscape Plan are submission requirements for this site plan application.
35. Retention of healthy trees over removal and replacement is a priority under the Official Plan (Section 4.8.2). Please follow a design with nature approach to accommodate existing trees wherever possible.
36. There is extensive hardscaping proposed on the site. The City of Ottawa is trying to reduce new surface parking lots and reduce the urban heat island effect. The design must align with Section 4.1.4, policy 11, of the Official Plan which introduces regular spacing and soil volume for trees throughout surface parking

lots. Consider alternative materials, like permeable pavement, to reduce the impacts of the paving proposed.

37. Landscaping provisions for parking lots is found under Section 110 of the Zoning By-law.
38. The City of Ottawa is working towards a 40% canopy cover target (Section 4.8.2 of the Official Plan). The site design should provide space for large canopy, native species, wherever feasible.
39. If there are geotechnical restrictions on site, the geotechnical consultant is asked to comment on whether the separation of the parking area from the building reduces and tree planting setback requirements.
40. Tree Conservation Report requirements. The following Tree Conservation Report (TCR) requirements have been adapted from the Schedule E of the Urban Tree Protection Guidelines – for more information on these requirements please contact hayley.murray@ottawa.ca
 - a. A Tree Conservation Report (TCR) must be supplied for review along with the suite of other plans/reports required by the City
 - b. Any tree 10 cm in diameter or greater and City-owned trees of any diameter requires a tree permit issued under the Tree Protection Bylaw (Bylaw 2020 – 340); the permit will be based on an approved TCR and made available at or near plan approval.
 - c. The TCR must contain 2 separate plans/maps:
 - i. Plan/Map 1 - show existing conditions with tree cover information.
 - ii. Plan/Map 2 - show proposed development with tree cover information.
 - d. The TCR must list all trees on site, as well as off-site trees if the CRZ (critical root zone) extends into the developed area, by species, diameter, and health condition. Please note that averages can be used if there are forested areas.
 - e. Please identify trees by ownership – private onsite, private on adjoining site, city owned, co-owned (trees on a property line)
 - f. If trees are to be removed, the TCR must clearly show where they are, and document the reason they cannot be retained.
 - g. The removal of trees on a property line will require the permission of both property owners.
 - h. All retained trees must be shown, and all retained trees within the area impacted by the development process must be protected as per City guidelines available at Tree Protection Specification or by searching Ottawa.ca
 - i. The city encourages the retention of healthy trees; if possible, please seek opportunities for retention of trees that will contribute to the design/function of the site.

- j. Removal of a City tree is not permitted unless justified. If justified, monetary compensation for the value of the tree must be paid before a tree removal permit is issued.

41. Landscape Plan (LP) requirements.

- a. Landscape Plan Terms of Reference must be adhered to for all tree planting: [Landscape Plan Terms of Reference](#). For more information on these requirements please contact hayley.murray@ottawa.ca

42. Additional Elements for Tree Planting in the Right of Way:

- a. Please ensure any retained trees are shown on the LP
- b. Sensitive Marine Clay - Please follow the City's 2017 Tree Planting in Sensitive Marine Clay guidelines.
- c. Soil Volume - Please demonstrate as per the Landscape Plan Terms of Reference that the available soil volumes for new plantings will meet or exceed the minimum soil volumes requested.
- d. The city requests that consideration be given to planting native species wherever there is a high probability of survival to maturity.
- e. Efforts shall be made to provide as much future canopy cover as possible at a site level, through tree planting and tree retention. The Landscape Plan shall show/document that the proposed tree planting and retention will contribute to the City's overall canopy cover over time. Please provide a projection of the future canopy cover for the site to 40 years
- f. Minimum Setbacks
 - i. Maintain 1.5m from sidewalk or MUP/cycle track or water service laterals.
 - ii. Maintain 2.5m from curb
 - iii. Coniferous species require a minimum 4.5m setback from curb, sidewalk, or MUP/cycle track/pathway.
 - iv. Maintain 7.5m between large growing trees, and 4m between small growing trees. Park or open space planting should consider 10m spacing, except where otherwise approved in naturalization / afforestation areas.
 - v. Adhere to Ottawa Hydro's planting guidelines (species and setbacks) when planting around overhead primary conductors.
- g. Tree specifications
 - vi. Minimum stock size: 50mm tree caliper for deciduous, 200cm height for coniferous.

- vii. Maximize the use of large deciduous species wherever possible to maximize future canopy coverage.
 - viii. Tree planting on city property shall be in accordance with the City of Ottawa's Tree Planting Specification; and if possible, include watering and warranty as described in the specification.
 - ix. No root barriers, dead-man anchor systems, or planters are permitted.
 - x. No tree stakes unless necessary (and only 1 on the prevailing winds side of the tree)
- h. Hard surface planting
- xi. If there are hard surface plantings, a planting detail must be provided.
 - xii. Curb style planters are highly recommended.
 - xiii. No grates are to be used and if guards are required, City of Ottawa standard (which can be provided) shall be used.
 - xiv. Trees are to be planted at grade.

Feel free to contact Hayley Murray, Planning Forester, for follow-up questions.

Parkland – Phil Castro

Comments:

43. Cash-in-lieu of parkland / parkland dedication will be required.

- a. Parkland Dedication [By-law No. 2022-280](#)

Feel free to contact Phil Castro, Parks Planner, for follow-up questions.

Housing Solutions and Investment Services (HSIS) – Edith Tam

44. Housing Solutions and Investment Services (HSIS) would be open to cost-sharing a sanitary sewer extension down Conroy Road to Johnston Road with the owners of 3145 Conroy. HSIS would also assist should the owners install watermain and storm infrastructure under the existing ROW on City property fronting Conroy Road subject to there being no objections during internal circulation.

Other

45. The High-Performance Development Standard (HPDS) is a collection of voluntary and required standards that raise the performance of new building projects to achieve sustainable and resilient design and will be applicable to Site Plan Control and Plan of Subdivision applications.

- a. The HPDS was passed by Council on April 13, 2022, but is not in effect at this time, as Council has referred the 2023 HPDS Update Report back to staff with the direction to bring forward an updated report to Committee at a later date. Please be advised that this is expected to occur in Q3 2024.
- b. Please refer to the HPDS information at ottawa.ca/HPDS for more information.

Submission Requirements and Fees

1. A Site Plan Control – Complex application is required.
 - a. Additional information regarding fees related to planning applications can be found [here](#).
2. The attached **Study and Plan Identification List** outlines the information and material that has been identified as either required (R) or advised (A) as part of a future complete application submission.
 - a. The required plans and studies must meet the City's Terms of Reference (ToR) and/or Guidelines, as available on Ottawa.ca. These ToR and Guidelines outline the specific requirements that must be met for each plan or study to be deemed adequate.
3. All of the above comments or issues should be addressed to ensure the effectiveness of the application submission review.

Should there be any questions, please do not hesitate to contact myself or the contact identified for the above areas / disciplines.

Yours Truly,
Tess Peterman

Encl. Study and Plan Identification List
Urban Design Brief Terms of Reference
List of Technical Agencies
Supplementary Development Information
ADS Site Plan Checklist

c.c. Siobhan Kelly, Development Review
Bruce Bramah, IPM
Rochelle Fortier-Lesage, TPM
Molly Smith, Urban Design
Mark Elliott, Environment
Hayley Murray, Forestry
Phil Castro, Parks & Facilities
Edith Tam, HSIS

APPENDIX C WATER SERVICE CALCULATIONS

CO-25-1505 - 3145 Conroy Rd. - Water Demands

Project:	3145 Conroy Rd.
Project No.:	CO-25-1505
Designed By:	FP
Checked By:	JB
Date:	July 29, 2025
Site Area:	4.86 gross ha

Residential	NUMBER OF UNITS	UNIT RATE
Commercial/ Amenity	790 m2	
Industrial - Heavy	2231 m2	

AVERAGE DAILY DEMAND

DEMAND TYPE	AMOUNT	UNITS	
Residential	280	L/ c/ d	
Industrial - Light	35,000	L/ gross ha/ d	
Industrial - Heavy	55,000	L/ gross ha/ d	
Shopping Centres	2,500	L/ (1000m ² / d)	
Hospital	900	L/ (bed/ day)	
Schools	70	L/ (Student/ d)	
Trailer Park with no Hook-Ups	340	L/ (space/ d)	
Trailer Park with Hook-Ups	800	L/ (space/ d)	
Campgrounds	225	L/ (campsite/ d)	
Mobile Home Parks	1,000	L/ (Space/ d)	
Motels	150	L/ (bed-space/ d)	
Hotels	225	L/ (bed-space/ d)	
Tourist Commercial	28,000	L/ gross ha/ d	
Other Commercial	28,000	L/ gross ha/ d	
AVERAGE DAILY DEMAND	Residential	0.00	L/ s
	Commercial/ Industrial/ Institutional	0.17	L/ s

MAXIMUM DAILY DEMAND

DEMAND TYPE	AMOUNT	UNITS	
Residential	9.5	x avg. day	
Industrial	1.5	x avg. day	
Commercial	1.5	x avg. day	
Institutional	1.5	x avg. day	
MAXIMUM DAILY DEMAND	Residential	0.00	L/ s
	Commercial/ Industrial/ Institutional	0.25	L/ s

MAXIMUM HOUR DEMAND

DEMAND TYPE	AMOUNT	UNITS	
Residential	14.3	x avg. day	
Industrial	1.8	x max. day	
Commercial	1.8	x max. day	
Institutional	1.8	x max. day	
MAXIMUM HOUR DEMAND	Residential	0.00	L/ s
	Commercial/ Industrial/ Institutional	0.45	L/ s

WATER DEMAND DESIGN FLOWS PER UNIT COUNT
CITY OF OTTAWA - WATER DISTRIBUTION GUIDELINES, JULY 2010

AVERAGE DAILY DEMAND	0.17	L/ s
MAXIMUM DAILY DEMAND	0.25	L/ s
MAXIMUM HOUR DEMAND	0.45	L/ s

CO-25-1505 - 3145 Conroy Rd. - OBC Fire Calculations

Project: 3145 Conroy Rd.
 Project No.: CO-25-1505
 Designed By: RP
 Checked By: JB
 Date: July 29, 2025

Ontario 2006 Building Code Compendium (Div. B - Part 3)

Water Supply for Fire-Fighting - Distillery, Restaurant & Retail Building

Building is classified as Group : F2 (from table 3.2.2.55)
 Building is of combustible construction with fire separations and fire resistance ratings provided in accordance with Subsection 3.2.2., including loadbearing walls, columns and arches. Noncombustible construction may be used in lieu of fire-resistance rating

From Div. B A-3.2.5.7. of the Ontario Building Code - 3. Building On-Site Water Supply:

(a) $Q = K \times V \times S_{tot}$

where:

Q = minimum supply of water in litres

K = water supply coefficient from Table 1

V = total building volume in cubic metres

S_{tot} = total of spatial coefficient values from the property line exposures on all sides as obtained from the formula:

$S_{tot} = 1.0 + [S_{side1} + S_{side2} + S_{side3} + \dots \text{etc.}]$

K	31	(from Table 1 pg A-31)
V	19,706	(Total building volume in m ³ .)
S_{tot}	1.0	(From figure 1 pg A-32)
Q =	610,886.00 L	

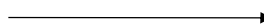

			From Figure 1 (A-32)
Snorth	100 m	0.0	
Seast	100 m	0.0	
Ssouth	100 m	0.0	
Swest	100 m	0.0	

* approximate distances

From Table 2: Required Minimum Water Supply Flow Rate (L/s)

9,000 L/min if Q > 270,000 L
 2378 gpm

OO-25-1505 - 3145 Conroy Road - Boundary Condition Unit Conversion

Project: 3145 Conroy Road
 Project No.: OO-25-1505
 Designed By: RP
 Checked By: CM
 Date: July 29, 2025

Boundary Conditions Unit Conversion

Conroy Road

Scenario	Height (m)	Elevation (m)	m H ₂ O	PSI	kPa	
Avg. DD	130.00	84.75	45.25	0.00	64.38	443.90
Fire Flow (200 L/s or 12,000 L/min)	126.40	84.75	41.65	5.28	59.26	408.59
Peak Hour	125.10	84.75	40.35	0.00	57.41	395.83

PCO-25-1505 - 3145 Conroy Road - Hydrant Availability

Project: 3145 Conroy Road
 Project No.: PCO-25-1505
 Designed By: RP
 Checked By: CM
 Date: July 29, 2025

Boundary Conditions Unit Conversion

AVAILABLE FIRE FLOWS BASED ON HYDRANT SPACING

BASED ON CITY OF OTTAWA TECHNICAL BULLETIN ISTB-2018-02

Location	Municipal or Private	Colour or Class (If Known)	296 Metcalfe Street	
			¹ Distance (m)	² Fire Flow Contribution (L/min)
Conroy Road	Municipal	Blue (assume class AA)	145	3,800
Proposed On-site	Private	Blue (assume class AA)	50	5,700
Total (L/min)				9,500
RUSRFF in L/min or (L/sec)				8,000 (133)
<u>Notes:</u>				
¹ Distance is measured along a road or fire route to nearest face of building.				
² Fire Flow Contribution based on Table 1 of Appendix I, ISTB-2018-02				



PICKARD Robert

From: Bramah, Bruce <bruce.bramah@ottawa.ca>
Sent: Monday, August 26, 2024 7:19 AM
To: PICKARD Robert
Subject: RE: 3145 Conroy - Boundary Conditions Request

Good morning,

Based on the size of the main, there will be no significant change to the HGL with 12,000 L/min. Please use the previous boundary conditions.

Thanks,

--

Bruce Bramah, P.Eng

Project Manager

Planning, Development, and Building Services Department | Direction générale des services de la planification, de l'aménagement et du bâtiment

Development Review - South Branch

City of Ottawa | Ville d'Ottawa

110 Laurier Avenue West Ottawa, ON | 110, avenue. Laurier Ouest. Ottawa (Ontario) K1P 1J1

613.580.2424 ext./poste 29686, Bruce.Bramah@ottawa.ca

From: PICKARD Robert <Robert.PICKARD@egis-group.com>
Sent: August 23, 2024 1:54 PM
To: Bramah, Bruce <bruce.bramah@ottawa.ca>
Subject: RE: 3145 Conroy - Boundary Conditions Request

CAUTION: This email originated from an External Sender. Please do not click links or open attachments unless you recognize the source.

ATTENTION : Ce courriel provient d'un expéditeur externe. Ne cliquez sur aucun lien et n'ouvrez pas de pièce jointe, excepté si vous connaissez l'expéditeur.

Hey Bruce,

Apologies for this and really appreciate the quick turn around. After reviewing our fire flows we think its best to be on the conservative side at the moment and use a fire flow of 12,000 L/min as attached. Could we get the updated Max Day + Fire Flow?

Thanks kindly,



Robbie Pickard

Engineering Intern - Land Development, North America

Phone: [+1 343-317-6702](tel:+13433176702), Mobile: [+1 613-808-3427](tel:+16138083427)

From: Bramah, Bruce <bruce.bramah@ottawa.ca>
Sent: Friday, August 23, 2024 7:10 AM
To: PICKARD Robert <Robert.PICKARD@egis-group.com>
Subject: RE: 3145 Conroy - Boundary Conditions Request

!/ Courriel externe - Merci d'être prudent avec les liens et les pièces jointes !/ External email - Please be careful with links and attachments !/

Good morning Robbie,

Quick turn around on this one.

The following are boundary conditions, HGL, for hydraulic analysis at 3145 Conroy Road (zone 2W2C) assumed to be connected to the 406mm watermain on Conroy Road (see attached PDF for location).

Minimum HGL = 125.1 m

Maximum HGL = 130.0 m

Max Day + Fire Flow (167 L/s) = 126.4 m

These are for current conditions and are based on computer model simulation.

Disclaimer: The boundary condition information is based on current operation of the city water distribution system. The computer model simulation is based on the best information available at the time. The operation of the water distribution system can change on a regular basis, resulting in a variation in boundary conditions. The physical properties of watermains deteriorate over time, as such must be assumed in the absence of actual field test data. The variation in physical watermain properties can therefore alter the results of the computer model simulation. Fire Flow analysis is a reflection of available flow in the watermain; there may be additional restrictions that occur between the watermain and the hydrant that the model cannot take into account.

Thanks,

--

Bruce Bramah, P.Eng

Project Manager

Planning, Development, and Building Services Department | Direction générale des services de la planification, de l'aménagement et du bâtiment

Development Review - South Branch

City of Ottawa | Ville d'Ottawa

110 Laurier Avenue West Ottawa, ON | 110, avenue. Laurier Ouest. Ottawa (Ontario) K1P 1J1

613.580.2424 ext./poste 29686, Bruce.Bramah@ottawa.ca

From: PICKARD Robert <Robert.PICKARD@egis-group.com>

Sent: August 20, 2024 11:22 AM

To: Bramah, Bruce <bruce.bramah@ottawa.ca>

Subject: 3145 Conroy - Boundary Conditions Request

CAUTION: This email originated from an External Sender. Please do not click links or open attachments unless you recognize the source.

ATTENTION : Ce courriel provient d'un expéditeur externe. Ne cliquez sur aucun lien et n'ouvrez pas de pièce jointe, excepté si vous connaissez l'expéditeur.

Hi Bruce,

We would like to request boundary conditions for the proposed development at 3145 Conroy Road. The development consists of a garage with office space. We will require boundary conditions for a potential connection to the existing 406mm watermain within Conroy Road.

Attached is a map highlighting the proposed connection location, along with calculations prepared for the following demands.

- The estimated fire flow is 10,000 L/min based on the 2020 FUS
- Average daily demand: 0.14 L/s
- Maximum daily demand: 0.21L/s
- Maximum hourly daily: 0.26 L/s

Should you have any questions or require further clarification, please do not hesitate to reach out.

Thank you,



Robbie Pickard
Engineering Intern - Land Development, North America
Phone: +1 343-317-6702, Mobile: +1 613-808-3427

Ce message et ses pièces jointes peuvent contenir des informations confidentielles ou privilégiées et ne doivent donc pas être diffusés, exploités ou copiés sans autorisation. Si vous avez reçu ce message par erreur, merci de le signaler à l'expéditeur et le détruire ainsi que les pièces jointes. Les messages électroniques étant susceptibles d'altération, Egis décline toute responsabilité si ce message a été altéré, déformé ou falsifié. Merci.

This message and its attachments may contain confidential or privileged information that may be protected by law; they should not be distributed, used or copied without authorisation. If you have received this email in error, please notify the sender and delete this message and its attachments. As emails may be altered, Egis is not liable for messages that have been modified, changed or falsified. Thank you.

This e-mail originates from the City of Ottawa e-mail system. Any distribution, use or copying of this e-mail or the information it contains by other than the intended recipient(s) is unauthorized. Thank you.

Le présent courriel a été expédié par le système de courriels de la Ville d'Ottawa. Toute distribution, utilisation ou reproduction du courriel ou des renseignements qui s'y trouvent par une personne autre que son destinataire prévu est interdite. Je vous remercie de votre collaboration.

Ce message et ses pièces jointes peuvent contenir des informations confidentielles ou privilégiées et ne doivent donc pas être diffusés, exploités ou copiés sans autorisation. Si vous avez reçu ce message par erreur, merci de le signaler à l'expéditeur et le détruire ainsi que les pièces jointes. Les messages électroniques étant susceptibles d'altération, Egis décline toute responsabilité si ce message a été altéré, déformé ou falsifié. Merci.

This message and its attachments may contain confidential or privileged information that may be protected by law; they should not be distributed, used or copied without authorisation. If you have received this email in error, please notify the sender and delete this message and its attachments. As emails may be altered, Egis is not liable for messages that have been modified, changed or falsified. Thank you.

This e-mail originates from the City of Ottawa e-mail system. Any distribution, use or copying of this e-mail or the information it contains by other than the intended recipient(s) is unauthorized. Thank you.

Le présent courriel a été expédié par le système de courriels de la Ville d'Ottawa. Toute distribution, utilisation ou reproduction du courriel ou des renseignements qui s'y trouvent par une personne autre que son destinataire prévu est interdite. Je vous remercie de votre collaboration.

APPENDIX D
SANITARY SERVICE CALCULATIONS





000-25-1505 - 3145 Conroy Road - Sanitary Demands

Project:	3145 Conroy Road
Project No.:	000-25-1505
Designed By:	RP
Checked By:	JB
Date:	March 12, 2026
Site Area	4.86 Gross ha
Industrial Area	3020.00 m ²

To account for the Truck Wash - additional Sanitary demand per the Ottawa Sewer Design Guidelines (400 L/truck/day). Estimated 40 trucks washed per day.

DESIGN PARAMETERS

Industrial Peaking Factor	5.5	*Check Ottawa Sewer Design Guidelines Appendix 4B
Institutional/Commercial Peaking Factor	1.5	*Check technical bulletin ISTB 2018-01 (Either use 1.0 or 1.5)
Residential Peaking Factor	3.80	* Using Harmon Formula = $1 + (14 / (4 + P^{0.5})) * 0.8$
Mannings coefficient (n)	0.013	
Demand (per capita)	350	L/day
Infiltration allowance	0.33	L/s/Ha

EXTRANEOUS FLOW ALLOWANCES

Infiltration / Inflow	Flow (L/s)
Dry	0.24
Wet	1.36
Total	1.60

AVERAGE DAILY DEMAND

DEMAND TYPE	AMOUNT	UNITS	POPULATION / AREA	Flow (L/s)
Residential	350	L/c/d		0
Industrial - Light**	35,000	L/gross ha/d		0
Industrial - Heavy**	55,000	L/gross ha/d	0.30	0.19
Commercial / Amenity	2,800	L/(1000m ² /d)		0
Truck Wash	400	L/Truck/d)	40	0.19
Hospital	900	L/(bed/day)		0
Schools	70	L/(Student/d)		0
Trailer Parks no Hook-Ups	340	L/(space/d)		0
Trailer Park with Hook-Ups	800	L/(space/d)		0
Campgrounds	225	L/(campsite/d)		0
Mobile Home Parks	1,000	L/(Space/d)		0
Motels	150	L/(bed-space/d)		0
Hotels	225	L/(bed-space/d)		0
Office	75	L/7.0m ² /d		0
Tourist Commercial	28,000	L/gross ha/d		0
Other Commercial	28,000	L/gross ha/d		0

AVERAGE RESIDENTIAL FLOW	0.00	L/s
PEAK RESIDENTIAL FLOW	0.00	L/s
AVERAGE ICI FLOW	0.38	L/s
PEAK INSTITUTIONAL/COMMERCIAL FLOW	0.00	L/s
PEAK INDUSTRIAL FLOW	2.08	L/s
TOTAL PEAK ICI FLOW	2.08	L/s

TOTAL SANITARY DEMAND

TOTAL ESTIMATED AVERAGE DRY WEATHER FLOW	0.62	L/s
TOTAL ESTIMATED PEAK DRY WEATHER FLOW	2.32	L/s
TOTAL ESTIMATED PEAK WET WEATHER FLOW	3.68	L/s

** PEAK INDUSTRIAL FLOW PER CITY OF OTTAWA SEWER DESIGN GUIDELINES APPENDIX 4B

SANITARY SEWER DESIGN SHEET



PROJECT: 3145 Conroy Road
 LOCATION: 3145 Conroy Road
 CLIENT: White Owl

LOCATION				TRUCK WASH				ICI AREAS						INFILTRATION ALLOWANCE		FLOW		SEWER DATA																		
STREET	AREA ID	FROM MH	TO MH	TRUCKS WASHED	PEAK FACTOR	PEAK FLOW (L/s)	AREA (ha)						PEAK FLOW (L/s)	AREA (ha)		FLOW (L/s)	DESIGN FLOW (L/s)	CAPACITY (L/s)	LENGTH (m)	DIA (mm)	SLOPE (%)	VELOCITY (full) (m/s)	AVAILABLE CAPACITY													
							INSTITUTIONAL		COMMERCIAL		INDUSTRIAL			IND	CUM								IND	CUM	IND	CUM	L/s	L/s	L/s	L/s	L/s	L/s	L/s	L/s	L/s	L/s
							IND	CUM	IND	CUM	IND	CUM																								
N/A	A-1	BLDG	MH3A	40.00	0.19	5.50	1.02					0.30	0.30	1.06	4.86	4.86	1.60	3.68	11.23	50.21	150	0.50	0.616	7.55	67.25											
N/A	A-1	MH3A	MH2A				1.02					0.30	0.30	1.06		4.86	1.60	3.68	11.23	61.98	150	0.50	0.616	7.55	67.25											
N/A	A-2	MH2A	MH1A				1.02					0.30	0.30	1.06		4.86	1.60	3.68	11.23	61.98	150	0.50	0.616	7.55	67.25											
N/A	A-1	MH1A	Conroy Rd				1.02					0.30	0.30	1.06		4.86	1.60	3.68	20.24	54.77	200	0.35	0.624	16.56	81.82											
Design Parameters:				0.013 L/day				Designed: FP						No.		Revision						Date														
Residential				ICI Areas				Checked: JB						1.		ISSUED FOR SUBMISSION						2026-02-24														
SF	3.4	p/p/u					Peak Factor	Project No.: PCO-25-1505																												
TH/SD	2.7	p/p/u	INST	28,000	L/Ha/day		1.5																													
APT	2.3	p/p/u	COM	28,000	L/Ha/day		1.5																													
Other	60	p/p/Ha	IND	55,000	L/Ha/day		5.5																													
																						Sheet No:														
																						1 of 1														

APPENDIX E
PRE-DEVELOPMENT DRAINAGE PLAN



APPENDIX F
POST-DEVELOPMENT DRAINAGE PLAN



APPENDIX G STORMWATER CALCULATIONS





CO-25-1370 - 3145 Conroy - SWM Calculations

Tc (min)	Intensity (mm/hr)			
	2-Year	5-Year	100-Year	
20	51.6	70.3	120.0	PRE-DEVELOPMENT
10	76.5	104.2	178.6	POST-DEVELOPMENT

C-Values	
Impervious	0.90
Gravel	0.60
Pervious	0.20

Pre-Development Runoff Coefficient

Drainage Area	Impervious Area (m ²)	Gravel (m ²)	Pervious Area (m ²)	Average C (2-year)	Average C (5-year)	Average C (100-year)
A1	5,100	550	42,950	0.28	0.28	0.33

Pre-Development Runoff Calculations

Drainage Area	Area (ha)	C 2-Year	C 5-Year	C 100-Year	Tc (min)	Q (L/s)		
						2-Year	5-Year	100-Year
A1	4.86	0.28	0.28	0.33	10	193.76	263.85	541.88
Total	4.86					193.76	263.85	541.88

Post-Development Runoff Coefficient

Drainage Area	Impervious	Gravel	Pervious Area	Average C	Average C	Average C
B1	9,600	0	1,577	0.80	0.80	0.89
B2	27,180	3,200	820	0.85	0.85	0.95
B3	0	200	6,023	0.21	0.21	0.27

Post-Development Runoff Calculations

Drainage Area	Area (ha)	C 2-Year	C 5-Year	C 100-Year	Tc (min)	Q (L/s)			
						2-Year	5-Year	100-Year	
B1	1.12	0.80	0.80	0.89	10	190.49	259.40	496.11	Front yard
B2	3.12	0.85	0.85	0.95	10	564.67	768.92	1478.51	Rear yard
B3	0.62	0.21	0.21	0.27	10	28.18	38.37	82.19	Uncontrolled
Total	4.86					783.34	1066.69	2056.81	

Required Post-Development Flow

Drainage Area	Q (L/s)
A1	263.85

* To match the five year pre-development flow, using the existing coefficient of 0.28.

Post-Development Restricted Runoff Calculations

Drainage Area	Unrestricted Flow (L/S)			Restricted Flow (L/S)			Storage Required (m ³)			Storage Provided (m ³)		
	2-year	5-year	100-Year	2-Year	5-Year	100-Year	2-Year	5-Year	100-Year	2-Year	5-Year	100-Year
B1	190.49	259.40	496.11	32.60	33.40	35.50	118.33	183.9	432.0	124.3	189.0	435.6
B2	564.67	768.92	1478.51	138.00	141.70	143.10	289.59	460.9	1,160.5	296.5	463.1	1,206.6
B3	28.18	38.37	82.19	28.18	38.37	82.19						
Total	783.34	1066.69	2056.81	198.78	213.47	260.79	407.92	644.86	1592.53	420.80	652.07	1642.16

Storage Requirements for Area B1

2-Year Storm Event

Tc (min)	I (mm/hr)	Runoff (L/s) B1	Allowable Outflow (L/s)	Runoff to be Stored (L/s)	Storage Required (m ³)
10	76.0	189.21	32.60	156.61	93.97
20	51.4	127.97	32.60	95.37	114.44
30	39.5	98.34	32.60	65.74	118.33
40	32.4	80.66	32.60	48.06	115.35
50	27.6	68.71	32.60	36.11	108.34

Maximum Storage Required 2-year = 118 m³

5-Year Storm Event

Tc (min)	I (mm/hr)	Runoff (L/s) B1	Allowable Outflow (L/s)	Runoff to be Stored (L/s)	Storage Required (m ³)
10	104.2	259.42	33.40	226.02	135.61
20	70.3	175.02	33.40	141.62	169.94
30	53.9	134.19	33.40	100.79	181.42
40	44.2	110.04	33.40	76.64	183.94
50	37.7	93.86	33.40	60.46	181.37

Maximum Storage Required 5-year = 184 m³

100-Year Storm Event

Tc (min)	I (mm/hr)	Runoff (L/s) B1	Allowable Outflow (L/s)	Runoff to be Stored (L/s)	Storage Required (m ³)
10	178.6	496.22	35.50	460.72	276.43
20	120.0	333.41	35.50	297.91	357.49
30	91.9	255.34	35.50	219.84	395.70
40	75.1	208.66	35.50	173.16	415.58
50	64.0	177.82	35.50	142.32	426.95
60	55.9	155.31	35.50	119.81	431.33
70	49.8	138.36	35.50	102.86	432.03
80	45.0	125.03	35.50	89.53	429.73
90	41.1	114.19	35.50	78.69	424.94
100	37.9	105.30	35.50	69.80	418.81

Maximum Storage Required 100-year = 432 m³

2-Year Storm Event Storage Summary

Water Elev. (m) = 83.5						
Location	T/G	INV. (out)	Area (m ²)	Depth (m)	Head (m)	Volume (m ³)
MH1	84.03	80.45	422.1	X	3.00	124.3

Storage Available (m³) = 124.3
Storage Required (m³) = 118.3

5-Year Storm Event Storage Summary

Water Elev. (m) = 83.64						
Location	T/G	INV. (out)	Area (m ²)	Depth (m)	Head (m)	Volume (m ³)
MH1	84.03	80.45	501.8	X	3.14	189.0

Storage Available (m³) = 189.0
Storage Required (m³) = 183.9

100-Year Storm Event Storage Summary

Water Elev. (m) = 84.04						
Location	T/G	INV. (out)	Area (m ²)	Depth (m)	Head (m)	Volume (m ³)
MH1	84.03	80.45	698.3	X	3.54	435.6

Storage Available (m³) = 435.6
Storage Required (m³) = 432.0

* Available Storage calculated from AutoCAD

For Orifice Flow, C= 0.6
 For Weir Flow, C= 3.33

		Orifice 1	Orifice 2	Weir 1	Weir 2
B1	Invert Elevation	80.45	NA		
	Center of Crest Elevation	80.50	NA		
	Orifice Width / Weir Length	95.00	NA		
	Orifice Height	NA	NA		
	Orifice Area (m ²)	0.007	NA		

Table B9 Elevation Discharge Table - Storm Routing

Elevation (m)	Orifice 1		Orifice 2		Weir 1		Weir 2		Total Q (L/s)
	H (m)	Q (m ³ /s)	H (m)	Q (m ³ /s)	H (m)	Q (m ³ /s)	H (m)	Q (m ³ /s)	
80.50	x	x	x	x	x	x	x	x	0.0
83.50	3.00	0.033	x	x	x	x	x	x	32.6
83.51	3.01	0.033	x	x	x	x	x	x	32.7
83.52	3.02	0.033	x	x	x	x	x	x	32.8
83.53	3.03	0.033	x	x	x	x	x	x	32.8
83.54	3.04	0.033	x	x	x	x	x	x	32.9
83.55	3.05	0.033	x	x	x	x	x	x	32.9
83.56	3.06	0.033	x	x	x	x	x	x	33.0
83.57	3.07	0.033	x	x	x	x	x	x	33.0
83.58	3.08	0.033	x	x	x	x	x	x	33.1
83.59	3.09	0.033	x	x	x	x	x	x	33.1
83.60	3.10	0.033	x	x	x	x	x	x	33.2
83.61	3.11	0.033	x	x	x	x	x	x	33.2
83.62	3.12	0.033	x	x	x	x	x	x	33.3
83.63	3.13	0.033	x	x	x	x	x	x	33.3
83.64	3.14	0.033	x	x	x	x	x	x	33.4
83.65	3.15	0.033	x	x	x	x	x	x	33.4
83.66	3.16	0.034	x	x	x	x	x	x	33.5
83.67	3.17	0.034	x	x	x	x	x	x	33.6
83.68	3.18	0.034	x	x	x	x	x	x	33.6
83.69	3.19	0.034	x	x	x	x	x	x	33.7
83.70	3.20	0.034	x	x	x	x	x	x	33.7
83.71	3.21	0.034	x	x	x	x	x	x	33.8
83.72	3.22	0.034	x	x	x	x	x	x	33.8
83.73	3.23	0.034	x	x	x	x	x	x	33.9
83.74	3.24	0.034	x	x	x	x	x	x	33.9
83.75	3.25	0.034	x	x	x	x	x	x	34.0
83.76	3.26	0.034	x	x	x	x	x	x	34.0
83.77	3.27	0.034	x	x	x	x	x	x	34.1
83.78	3.28	0.034	x	x	x	x	x	x	34.1
83.79	3.29	0.034	x	x	x	x	x	x	34.2
83.80	3.30	0.034	x	x	x	x	x	x	34.2
83.81	3.31	0.034	x	x	x	x	x	x	34.3
83.82	3.32	0.034	x	x	x	x	x	x	34.3
83.83	3.33	0.034	x	x	x	x	x	x	34.4
83.84	3.34	0.034	x	x	x	x	x	x	34.4
83.85	3.35	0.034	x	x	x	x	x	x	34.5
83.86	3.36	0.035	x	x	x	x	x	x	34.5
83.87	3.37	0.035	x	x	x	x	x	x	34.6
83.88	3.38	0.035	x	x	x	x	x	x	34.6
83.89	3.39	0.035	x	x	x	x	x	x	34.7
83.90	3.40	0.035	x	x	x	x	x	x	34.7
83.91	3.41	0.035	x	x	x	x	x	x	34.8
83.92	3.42	0.035	x	x	x	x	x	x	34.9
83.93	3.43	0.035	x	x	x	x	x	x	34.9
83.94	3.44	0.035	x	x	x	x	x	x	35.0
83.95	3.45	0.035	x	x	x	x	x	x	35.0
83.96	3.46	0.035	x	x	x	x	x	x	35.1
83.97	3.47	0.035	x	x	x	x	x	x	35.1
83.98	3.48	0.035	x	x	x	x	x	x	35.2
83.99	3.49	0.035	x	x	x	x	x	x	35.2
84.00	3.50	0.035	x	x	x	x	x	x	35.3
84.01	3.51	0.035	x	x	x	x	x	x	35.3
84.02	3.52	0.035	x	x	x	x	x	x	35.4
84.03	3.53	0.035	x	x	x	x	x	x	35.4
84.04	3.54	0.035	x	x	x	x	x	x	35.5
84.05	3.55	0.036	x	x	x	x	x	x	35.5
84.06	3.56	0.036	x	x	x	x	x	x	35.6
84.07	3.57	0.036	x	x	x	x	x	x	35.6
84.08	3.58	0.036	x	x	x	x	x	x	35.7
84.09	3.59	0.036	x	x	x	x	x	x	35.7
84.10	3.60	0.036	x	x	x	x	x	x	35.8

1. For Orifice Flow, User is to Input an Elevation Higher than Crown of Orifice.
2. Orifice Equation: $Q = cA(2gh)^{1/2}$
3. Weir Equation: $Q = cLH^{3/2}$
4. These Computations Do Not Account for Submergence Effects Within the Pond Riser.
5. H for orifice equations is depth of water above the centroid of the orifice.
6. H for weir equations is depth of water above the weir crest.

Storage Requirements for Area B2

2-Year Storm Event

Tc (min)	I (mm/hr)	Runoff (L/s) B2	Allowable Outflow (L/s)	Runoff to be Stored (L/s)	Storage Required (m ³)
0	166.0	1,225.04	138.00	1,087.04	0.00
10	76.0	560.86	138.00	422.86	253.72
20	51.4	379.32	138.00	241.32	289.59
25	44.5	328.40	138.00	190.40	285.60
30	39.5	291.50	138.00	153.50	276.30

Maximum Storage Required 2-year =	290 m ³
-----------------------------------	--------------------

* Pipe system and underground infrastructure has 296.5m³ capacity*

5-Year Storm Event

Tc (min)	I (mm/hr)	Runoff (L/s) B2	Allowable Outflow (L/s)	Runoff to be Stored (L/s)	Storage Required (m ³)
0	230.5	1,701.04	141.70	1,559.34	0.00
10	104.2	768.97	141.70	627.27	376.36
20	70.3	518.80	141.70	377.10	452.52
30	53.9	397.77	141.70	256.07	460.93
40	44.2	326.19	141.70	184.49	442.77

Maximum Storage Required 5-year =	461 m ³
-----------------------------------	--------------------

100-Year Storm Event

Tc (min)	I (mm/hr)	Runoff (L/s) B2	Allowable Outflow (L/s)	Runoff to be Stored (L/s)	Storage Required (m ³)
0	398.6	3,300.50	143.10	3,157.40	0.00
10	178.6	1,478.85	143.10	1,335.75	801.45
20	120.0	993.63	143.10	850.53	1,020.63
30	91.9	760.95	143.10	617.85	1,112.14
40	75.1	621.85	143.10	478.75	1,148.99
50	64.0	529.93	143.10	386.83	1,160.50
60	55.9	462.86	143.10	319.76	1,151.15
70	49.8	412.36	143.10	269.26	1,130.87
80	45.0	372.61	143.10	229.51	1,101.65
90	41.1	340.32	143.10	197.22	1,064.97

Maximum Storage Required 100-year =	1161 m ³
-------------------------------------	---------------------

2-Year Storm Event Storage Summary

		Water Elev. (m) =		84.00		
Location	T/G	INV. (out)	Area (m ²)	Depth (m)	Head (m)	Volume (m ³)
CBMH9	84.00	79.34	0.0	X	4.66	296.5

Storage Available (m ³) =	296.5
Storage Required (m ³) =	289.6

* Pipe system and underground infrastructure has 296.5m³ capacity*

5-Year Storm Event Storage Summary

		Water Elev. (m) =		84.25		
Location	T/G	INV. (out)	Area (m ²)	Depth (m)	Head (m)	Volume (m ³)
CBMH9	84.00	79.34	5340.4	0.25	4.91	463.1

Storage Available (m ³) =	463.1
Storage Required (m ³) =	460.9

100-Year Storm Event Storage Summary

		Water Elev. (m) =		84.35		
Location	T/G	INV. (out)	Area (m ²)	Depth (m)	Head (m)	Volume (m ³)
CBMH9	84.00	79.34	7997.5	0.35	5.01	1206.6

Storage Available (m ³) =	1206.6
Storage Required (m ³) =	1160.5

* Available Storage calculated from AutoCAD

For Orifice Flow, C= 0.6
 For Weir Flow, C= 3.33

	Orifice 1	Orifice 2	Weir 1	Weir 2
B2				
Invert Elevation	79.25	NA		
Center of Crest Elevation	79.34	NA		
Orifice Width / Weir Length	175.00	NA		
Orifice Height	NA	NA		
Orifice Area (m ²)	0.024	NA		

Table B9 Elevation Discharge Table - Storm Routing

Elevation (m)	Orifice 1		Orifice 2		Weir 1		Weir 2		Total Q (L/s)
	H (m)	Q (m ³ /s)	H (m)	Q (m ³ /s)	H (m)	Q (m ³ /s)	H (m)	Q (m ³ /s)	
79.34	x	x	x	x	x	x	x	x	0.0
83.90	4.56	0.137	x	x	x	x	x	x	136.5
83.91	4.57	0.137	x	x	x	x	x	x	136.7
83.92	4.58	0.137	x	x	x	x	x	x	136.8
83.93	4.59	0.137	x	x	x	x	x	x	137.0
83.94	4.60	0.137	x	x	x	x	x	x	137.1
83.95	4.61	0.137	x	x	x	x	x	x	137.3
83.96	4.62	0.137	x	x	x	x	x	x	137.4
83.97	4.63	0.138	x	x	x	x	x	x	137.6
83.98	4.64	0.138	x	x	x	x	x	x	137.7
83.99	4.65	0.138	x	x	x	x	x	x	137.9
84.00	4.66	0.138	x	x	x	x	x	x	138.0
84.01	4.67	0.138	x	x	x	x	x	x	138.2
84.02	4.68	0.138	x	x	x	x	x	x	138.3
84.03	4.69	0.138	x	x	x	x	x	x	138.5
84.04	4.70	0.139	x	x	x	x	x	x	138.6
84.05	4.71	0.139	x	x	x	x	x	x	138.8
84.06	4.72	0.139	x	x	x	x	x	x	138.9
84.07	4.73	0.139	x	x	x	x	x	x	139.1
84.08	4.74	0.139	x	x	x	x	x	x	139.2
84.09	4.75	0.139	x	x	x	x	x	x	139.4
84.10	4.76	0.140	x	x	x	x	x	x	139.5
84.11	4.77	0.140	x	x	x	x	x	x	139.6
84.12	4.78	0.140	x	x	x	x	x	x	139.8
84.13	4.79	0.140	x	x	x	x	x	x	139.9
84.14	4.80	0.140	x	x	x	x	x	x	140.1
84.15	4.81	0.140	x	x	x	x	x	x	140.2
84.16	4.82	0.140	x	x	x	x	x	x	140.4
84.17	4.83	0.141	x	x	x	x	x	x	140.5
84.18	4.84	0.141	x	x	x	x	x	x	140.7
84.19	4.85	0.141	x	x	x	x	x	x	140.8
84.20	4.86	0.141	x	x	x	x	x	x	141.0
84.21	4.87	0.141	x	x	x	x	x	x	141.1
84.22	4.88	0.141	x	x	x	x	x	x	141.3
84.23	4.89	0.141	x	x	x	x	x	x	141.4
84.24	4.90	0.142	x	x	x	x	x	x	141.5
84.25	4.91	0.142	x	x	x	x	x	x	141.7
84.26	4.92	0.142	x	x	x	x	x	x	141.8
84.27	4.93	0.142	x	x	x	x	x	x	142.0
84.28	4.94	0.142	x	x	x	x	x	x	142.1
84.29	4.95	0.142	x	x	x	x	x	x	142.3
84.30	4.96	0.142	x	x	x	x	x	x	142.4
84.31	4.97	0.143	x	x	x	x	x	x	142.5
84.32	4.98	0.143	x	x	x	x	x	x	142.7
84.33	4.99	0.143	x	x	x	x	x	x	142.8
84.34	5.00	0.143	x	x	x	x	x	x	143.0
84.35	5.01	0.143	x	x	x	x	x	x	143.1
84.36	5.02	0.143	x	x	x	x	x	x	143.3
84.37	5.03	0.143	x	x	x	x	x	x	143.4
84.38	5.04	0.144	x	x	x	x	x	x	143.5
84.39	5.05	0.144	x	x	x	x	x	x	143.7
84.40	5.06	0.144	x	x	x	x	x	x	143.8
84.41	5.07	0.144	x	x	x	x	x	x	144.0
84.42	5.08	0.144	x	x	x	x	x	x	144.1
84.43	5.09	0.144	x	x	x	x	x	x	144.3
84.44	5.10	0.144	x	x	x	x	x	x	144.4
84.45	5.11	0.145	x	x	x	x	x	x	144.5
84.46	5.12	0.145	x	x	x	x	x	x	144.7
84.47	5.13	0.145	x	x	x	x	x	x	144.8
84.48	5.14	0.145	x	x	x	x	x	x	145.0
84.49	5.15	0.145	x	x	x	x	x	x	145.1
84.50	5.16	0.145	x	x	x	x	x	x	145.2

1. For Orifice Flow, User is to Input an Elevation Higher than Crown of Orifice.
2. Orifice Equation: $Q = cA(2gh)^{1/2}$
3. Weir Equation: $Q = cLH^{3/2}$
4. These Computations Do Not Account for Submergence Effects Within the Pond Riser.
5. H for orifice equations is depth of water above the centroid of the orifice.
6. H for weir equations is depth of water above the weir crest.



Time of Concentration Pre-Development

Drainage Area ID	Sheet Flow Distance (m)	Slope of Land (%)	Tc (min) (5-Year)	Tc (min) (100-Year)
A1	55	1.00	20	19

Therefore, a Tc of 20 can be used

$$Tc = (3.26(1.1-c)L^{0.5}/S^{0.33})$$

c = Balanced Runoff Coefficient

L = Length of drainage area

S = Average slope of watershed

STORM SEWER DESIGN SHEET

PROJECT: CCO-25-1505
 LOCATION: 3145 Conroy Rd
 CLIENT: Miller Waste Systems

LOCATION				CONTRIBUTING AREA (ha)				RATIONAL DESIGN FLOW										SEWER DATA									
1	2	3	4	5	6	7	8	9	10	11	12	13	14	15	16	17	18	19	20	21	22	23	24	25	26	27	28
STREET	AREA ID	FROM MH	TO MH	C-VALUE	AREA	INDIV AC	CUMUL AC	INLET (min)	TIME IN PIPE	TOTAL (min)	i (5) (mm/hr)	i (10) (mm/hr)	i (100) (mm/hr)	5yr PEAK FLOW (L/s)	10yr PEAK FLOW (L/s)	100yr PEAK FLOW (L/s)	FIXED FLOW (L/s)	DESIGN FLOW (L/s)	CAPACITY (L/s)	LENGTH (m)	PIPE SIZE (mm)			SLOPE (%)	VELOCITY (m/s)	AVAIL CAP (5yr)	
																					DIA	W	H			(L/s)	(%)
	B2	CB1	CBMH1	0.90	0.25	0.23	0.23	10.00	0.50	10.50	104.19	122.14	178.56	65.17	76.40	111.69		65.17	620.09	49.96	675			0.50	1.679	554.91	89.49%
	B2	CBMH1	CBMH2	0.90	0.12	0.11	0.33	10.50	0.42	10.91	101.64	119.14	174.15	94.10	110.29	161.22		94.10	821.24	45.05	750			0.50	1.801	727.15	88.54%
	B2	CBMH2	CBMH3	0.90	0.21	0.19	0.52	10.91	0.45	11.36	99.61	116.74	170.62	144.54	169.41	247.60		144.54	821.24	48.54	750			0.50	1.801	676.70	82.40%
	B2	CB2	CBMH4	0.90	0.15	0.14	0.14	10.00	0.49	10.49	104.19	122.14	178.56	39.10	45.84	67.01		39.10	620.09	49.17	675			0.50	1.679	580.98	93.69%
	B2	CB3	CBMH5	0.90	0.15	0.14	0.14	10.00	0.50	10.50	104.19	122.14	178.56	39.10	45.84	67.01		39.10	620.09	49.92	675			0.50	1.679	580.98	93.69%
	B2	CB4	CBMH6	0.90	0.15	0.14	0.14	10.00	0.51	10.51	104.19	122.14	178.56	39.10	45.84	67.01		39.10	620.09	51.42	675			0.50	1.679	580.98	93.69%
	B2	CB5	CBMH7	0.90	0.15	0.14	0.14	10.00	0.51	10.51	104.19	122.14	178.56	39.10	45.84	67.01		39.10	620.09	51.40	675			0.50	1.679	580.98	93.69%
	B2	CBMH7	CBMH6	0.90	0.17	0.15	0.29	10.00	0.31	10.31	104.19	122.14	178.56	83.42	97.79	142.96		83.42	821.24	33.50	750			0.50	1.801	737.82	89.84%
	B2	CBMH6	CBMH5	0.90	0.17	0.15	0.44	10.31	0.31	10.62	102.58	120.25	175.77	125.76	147.42	215.49		125.76	821.24	33.50	750			0.50	1.801	695.48	84.69%
	B2	CBMH5	CBMH4	0.90	0.17	0.15	0.59	10.62	0.31	10.93	101.03	118.41	173.08	166.83	195.54	285.81		166.83	821.24	33.50	750			0.50	1.801	654.41	79.69%
	B2	CBMH4	CBMH3	0.90	0.17	0.15	0.75	10.93	0.31	11.24	99.52	116.64	170.48	206.68	242.23	354.03		206.68	821.24	33.50	750			0.50	1.801	614.57	74.83%
	B2	CBMH4	CBMH3	0.90	0.19	0.17	0.92	11.24	0.31	11.55	98.07	114.93	167.96	250.28	293.30	428.65		250.28	821.24	33.50	750			0.50	1.801	570.97	69.52%
	B2	CBMH3	CBMH8	0.90	0.21	0.19	1.63	11.55	0.60	12.15	96.66	113.27	165.53	437.74	512.96	749.62		437.74	821.24	65.32	750			0.50	1.801	383.50	46.70%
	B2	CBMH8	CBMH9	0.90	0.30	0.27	1.90	12.15	0.38	12.54	94.04	110.19	161.00	496.46	581.70	849.95		496.46	821.24	41.35	750			0.50	1.801	324.78	39.55%
	B2	CBMH9	OGS1	0.90	0.20	0.18	2.08	12.54	1.26	13.80	92.46	108.33	158.27	534.39	626.09	914.75	155.00	534.39	821.24	136.64	750			0.50	1.801	286.85	34.93%
	B1	CB7	Storage	0.90	0.42	0.38	0.38	10.00	1.07	11.07	104.19	122.14	178.56	109.49	128.35	187.64		109.49	111.26	62.52	375			0.37	0.976	1.77	1.59%
	B1	CB6	Storage	0.90	0.38	0.34	0.34	10.00	0.08	10.08	104.19	122.14	178.56	99.06	116.13	169.77		99.06	111.26	4.76	375			0.37	0.976	12.20	10.96%
	B1	Storage	MH1	0.65	0.44		0.29	10.00	0.07	10.07	104.19	122.14	178.56	181.90	213.24	311.74		181.90	374.86	13.25	375			4.20	3.288	192.95	51.47%
	B1	MH1	OGS1				0.63	10.07	0.07	10.14	103.84	121.73	177.95	181.29	212.51	310.67	44.00	181.29	364.28	9.09	450			1.50	2.219	182.99	50.23%
	B1	OGS1	MH2				2.71	10.14	0.08	10.22	103.48	121.31	177.33	778.76	912.88	1,334.49		778.76	821.24	9.09	750			0.50	1.801	42.49	5.17%
	B1	MH2	MH3				2.71	10.00	0.93	10.93	104.19	122.14	178.56	784.10	919.17	1,343.74		784.10	821.24	100.32	750			0.50	1.801	37.14	4.52%

Definitions:
 Q = 2.78CA, where:
 Q = Peak Flow in Litres per Second (L/s)
 A = Area in Hectares (ha)
 i = Rainfall intensity in millimeters per hour (mm/hr)
 [i = 998.071 / (TC+6.053)^0.814] 5 YEAR
 [i = 1174.184 / (TC+6.014)^0.816] 10 YEAR
 [i = 1735.688 / (TC+6.014)^0.820] 100 YEAR

Notes:
 1. Mannings coefficient (n) = 0.013

Designed:
 No. 1.
 R.P.
 Checked:
 A.G.
 Project No.: CCO-25-1505

Revision
 No. 1. Submission
 Date: 2025-11-13

Date:
 2023.01.12
Sheet No:
 1 of 1

Stormceptor® EF Sizing Report

Imbrium® Systems

ESTIMATED NET ANNUAL SEDIMENT (TSS) LOAD REDUCTION

07/31/2025

Province:	Ontario
City:	Ottawa
Nearest Rainfall Station:	OTTAWA CDA RCS
Climate Station Id:	6105978
Years of Rainfall Data:	20

Project Name:	3145 Conroy
Project Number:	68450
Designer Name:	ROBBIE PICKARD
Designer Company:	EGIS
Designer Email:	robert.pickard@egis-group.com
Designer Phone:	613-808-3427
EOR Name:	
EOR Company:	
EOR Email:	
EOR Phone:	

Site Name:

Drainage Area (ha):	4.46
% Imperviousness:	97.00

Runoff Coefficient 'c': 0.88

Particle Size Distribution:	Fine
Target TSS Removal (%):	80.0

Required Water Quality Runoff Volume Capture (%):	90.00
Estimated Water Quality Flow Rate (L/s):	126.96
Oil / Fuel Spill Risk Site?	Yes
Upstream Flow Control?	Yes
Upstream Orifice Control Flow Rate to Stormceptor (L/s):	154.00
Peak Conveyance (maximum) Flow Rate (L/s):	
Influent TSS Concentration (mg/L):	100
Estimated Average Annual Sediment Load (kg/yr):	2355
Estimated Average Annual Sediment Volume (L/yr):	1914

Net Annual Sediment (TSS) Load Reduction Sizing Summary	
Stormceptor Model	TSS Removal Provided (%)
EFO4	44
EFO5	53
EFO6	61
EFO8	73
EFO10	80
EFO12	87

Recommended Stormceptor EFO Model: EFO10

Estimated Net Annual Sediment (TSS) Load Reduction (%): 80

Water Quality Runoff Volume Capture (%): > 90

THIRD-PARTY TESTING AND VERIFICATION

► **Stormceptor® EF and Stormceptor® EFO** are the latest evolutions in the Stormceptor® oil-grit separator (OGS) technology series, and are designed to remove a wide variety of pollutants from stormwater and snowmelt runoff. These technologies have been third-party tested in accordance with the Canadian ETV **Procedure for Laboratory Testing of Oil-Grit Separators** and performance has been third-party verified in accordance with the **ISO 14034 Environmental Technology Verification (ETV)** protocol.

PERFORMANCE

► **Stormceptor® EF and EFO** remove stormwater pollutants through gravity separation and floatation, and feature a patent-pending design that generates positive removal of total suspended solids (TSS) throughout each storm event, including high-intensity storms. Captured pollutants include sediment, free oils, and sediment-bound pollutants such as nutrients, heavy metals, and petroleum hydrocarbons. Stormceptor is sized to remove a high level of TSS from the frequent rainfall events that contribute the vast majority of annual runoff volume and pollutant load. The technology incorporates an internal bypass to convey excessive stormwater flows from high-intensity storms through the device without resuspension and washout (scour) of previously captured pollutants. Proper routine maintenance ensures high pollutant removal performance and protection of downstream waterways.

PARTICLE SIZE DISTRIBUTION (PSD)

► The **Canadian ETV PSD** shown in the table below was used, or in part, for this sizing. This is the identical PSD that is referenced in the Canadian ETV **Procedure for Laboratory Testing of Oil-Grit Separators** for both sediment removal testing and scour testing. The Canadian ETV PSD contains a wide range of particle sizes in the sand and silt fractions, and is considered reasonably representative of the particle size fractions found in typical urban stormwater runoff.

Particle Size (µm)	Percent Less Than	Particle Size Fraction (µm)	Percent
1000	100	500-1000	5
500	95	250-500	5
250	90	150-250	15
150	75	100-150	15
100	60	75-100	10
75	50	50-75	5
50	45	20-50	10
20	35	8-20	15
8	20	5-8	10
5	10	2-5	5
2	5	<2	5

Stormceptor® EF Sizing Report

Upstream Flow Controlled Results

Rainfall Intensity (mm / hr)	Percent Rainfall Volume (%)	Cumulative Rainfall Volume (%)	Flow Rate (L/s)	Flow Rate (L/min)	Surface Loading Rate (L/min/m²)	Removal Efficiency (%)	Incremental Removal (%)	Cumulative Removal (%)
0.50	8.6	8.6	5.47	328.0	45.0	100	8.6	8.6
1.00	20.3	29.0	10.94	656.0	90.0	97	19.8	28.4
2.00	16.2	45.2	21.87	1312.0	180.0	86	13.9	42.3
3.00	12.0	57.2	32.81	1968.0	270.0	80	9.6	51.9
4.00	8.4	65.6	43.74	2625.0	360.0	76	6.4	58.2
5.00	5.9	71.6	54.68	3281.0	449.0	72	4.3	62.5
6.00	4.6	76.2	65.61	3937.0	539.0	67	3.1	65.6
7.00	3.1	79.3	76.55	4593.0	629.0	64	2.0	67.6
8.00	2.7	82.0	87.49	5249.0	719.0	64	1.7	69.3
9.00	3.3	85.3	98.42	5905.0	809.0	63	2.1	71.4
10.00	2.3	87.6	109.36	6561.0	899.0	62	1.4	72.9
11.00	1.6	89.2	120.29	7218.0	989.0	62	1.0	73.8
12.00	1.3	90.5	131.23	7874.0	1079.0	60	0.8	74.6
13.00	1.7	92.2	142.16	8530.0	1168.0	58	1.0	75.6
14.00	7.8	100.0	153.10	9186.0	1258.0	56	4.3	80.0
15.00	0.0	100.0	154.00	9240.0	1266.0	56	0.0	80.0
16.00	0.0	100.0	154.00	9240.0	1266.0	56	0.0	80.0
17.00	0.0	100.0	154.00	9240.0	1266.0	56	0.0	80.0
18.00	0.0	100.0	154.00	9240.0	1266.0	56	0.0	80.0
19.00	0.0	100.0	154.00	9240.0	1266.0	56	0.0	80.0
20.00	0.0	100.0	154.00	9240.0	1266.0	56	0.0	80.0
21.00	0.0	100.0	154.00	9240.0	1266.0	56	0.0	80.0
22.00	0.0	100.0	154.00	9240.0	1266.0	56	0.0	80.0
23.00	0.0	100.0	154.00	9240.0	1266.0	56	0.0	80.0
24.00	0.0	100.0	154.00	9240.0	1266.0	56	0.0	80.0
25.00	0.0	100.0	154.00	9240.0	1266.0	56	0.0	80.0
30.00	0.0	100.0	154.00	9240.0	1266.0	56	0.0	80.0
35.00	0.0	100.0	154.00	9240.0	1266.0	56	0.0	80.0
40.00	0.0	100.0	154.00	9240.0	1266.0	56	0.0	80.0
45.00	0.0	100.0	154.00	9240.0	1266.0	56	0.0	80.0
Estimated Net Annual Sediment (TSS) Load Reduction =								80 %

Climate Station ID: 6105978 Years of Rainfall Data: 20

Stormceptor® EF Sizing Report

RAINFALL DATA FROM OTTAWA CDA RCS RAINFALL STATION

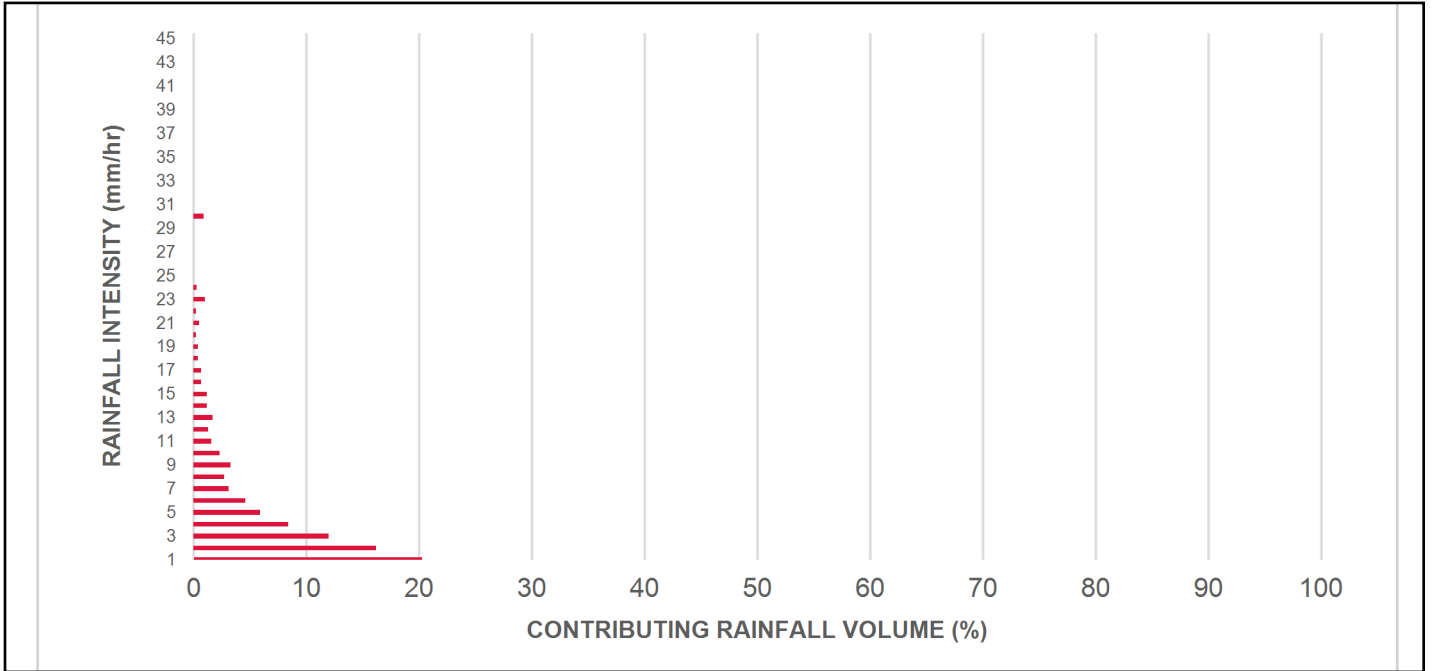

INCREMENTAL AND CUMULATIVE TSS REMOVAL FOR THE RECOMMENDED STORMCEPTOR® MODEL

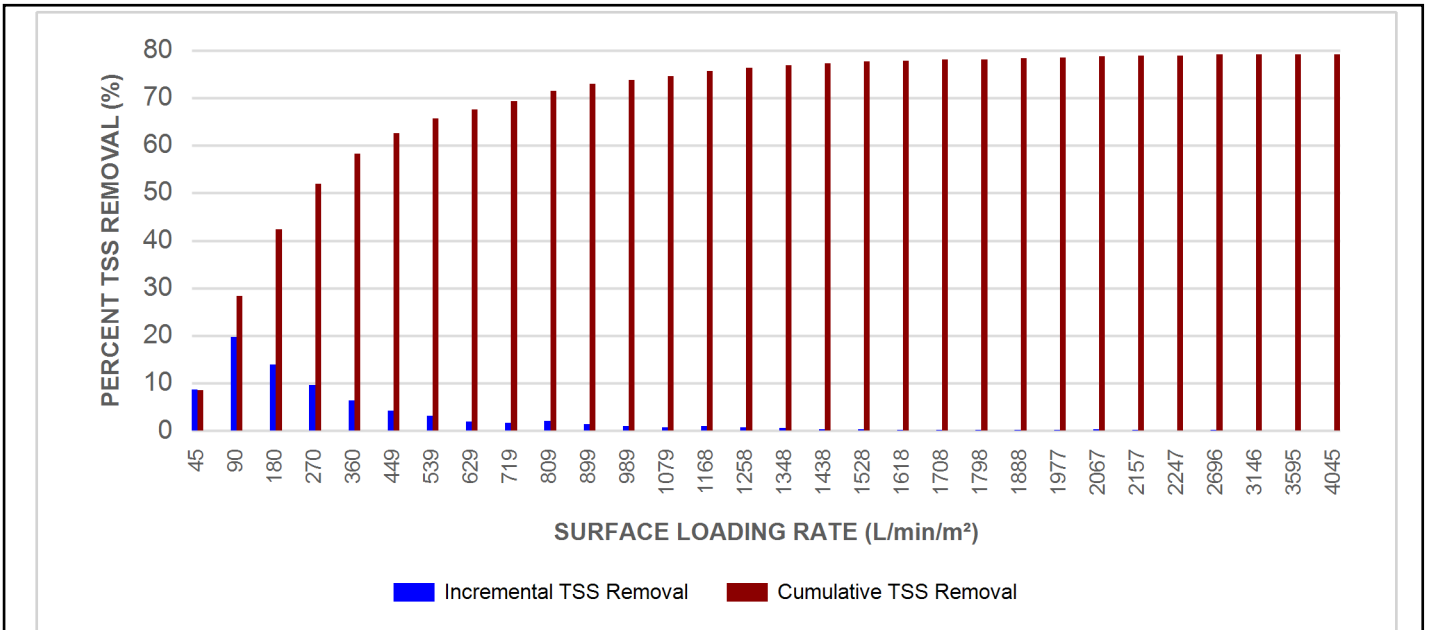

Stormceptor® EF Sizing Report

Maximum Pipe Diameter / Peak Conveyance

Stormceptor EF / EFO	Model Diameter		Min Angle Inlet / Outlet Pipes	Max Inlet Pipe Diameter		Max Outlet Pipe Diameter		Peak Conveyance Flow Rate	
	(m)	(ft)		(mm)	(in)	(mm)	(in)	(L/s)	(cfs)
EF4 / EFO4	1.2	4	90	609	24	609	24	425	15
EF5 / EFO5	1.5	5	90	762	30	762	30	710	25
EF6 / EFO6	1.8	6	90	914	36	914	36	990	35
EF8 / EFO8	2.4	8	90	1219	48	1219	48	1700	60
EF10 / EFO10	3.0	10	90	1828	72	1828	72	2830	100
EF12 / EFO12	3.6	12	90	1828	72	1828	72	2830	100

SCOUR PREVENTION AND ONLINE CONFIGURATION

► **Stormceptor® EF and EFO** feature an internal bypass and superior scour prevention technology that have been demonstrated in third-party testing according to the scour testing provisions of the Canadian ETV **Procedure for Laboratory Testing of Oil-Grit Separators**, and the exceptional scour test performance has been third-party verified in accordance with the ISO 14034 ETV protocol. As a result, Stormceptor EF and EFO are approved for online installation, eliminating the need for costly additional bypass structures, piping, and installation expense.

DESIGN FLEXIBILITY

► **Stormceptor® EF and EFO** offers design flexibility in one simplified platform, accepting stormwater flow from a single inlet pipe or multiple inlet pipes, and/or surface runoff through an inlet grate. The device can also serve as a junction structure, accommodate a 90-degree inlet-to-outlet bend angle, and can be modified to ensure performance in submerged conditions.

OIL CAPTURE AND RETENTION

► While Stormceptor® EF will capture and retain oil from dry weather spills and low intensity runoff, **Stormceptor® EFO** has demonstrated superior oil capture and greater than 99% oil retention in third-party testing according to the light liquid re-entrainment testing provisions of the Canadian ETV **Procedure for Laboratory Testing of Oil-Grit Separators**. Stormceptor EFO is recommended for sites where oil capture and retention is a requirement.

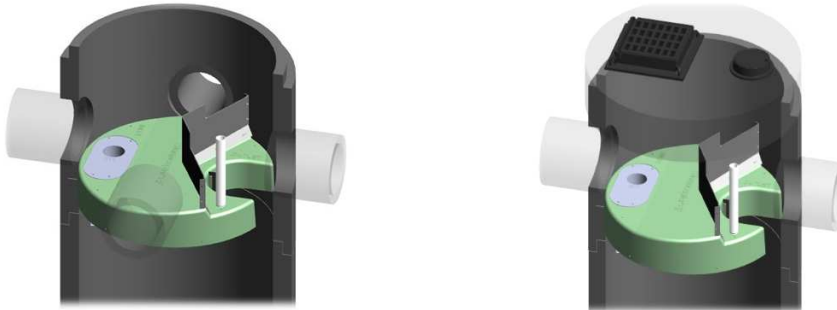

Stormceptor® EF Sizing Report

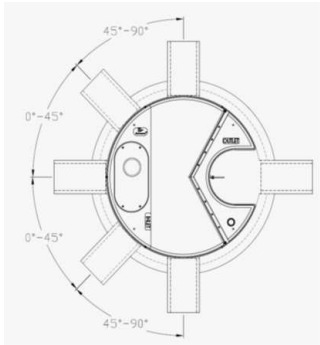

INLET-TO-OUTLET DROP

Elevation differential between inlet and outlet pipe inverts is dictated by the angle at which the inlet pipe(s) enters the unit.

0° - 45° : The inlet pipe is 1-inch (25mm) higher than the outlet pipe.

45° - 90° : The inlet pipe is 2-inches (50mm) higher than the outlet pipe.

HEAD LOSS

The head loss through Stormceptor EF is similar to that of a 60-degree bend structure. The applicable K value for calculating minor losses through the unit is 1.1. For submerged conditions the applicable K value is 3.0.

Pollutant Capacity

Stormceptor EF / EFO	Model Diameter		Depth (Outlet Pipe Invert to Sump Floor)		Oil Volume		Recommended Sediment Maintenance Depth *		Maximum Sediment Volume *		Maximum Sediment Mass **	
	(m)	(ft)	(m)	(ft)	(L)	(Gal)	(mm)	(in)	(L)	(ft³)	(kg)	(lb)
EF4 / EFO4	1.2	4	1.52	5.0	265	70	203	8	1190	42	1904	5250
EF5 / EFO5	1.5	5	1.62	5.3	420	111	305	10	2124	75	2612	5758
EF6 / EFO6	1.8	6	1.93	6.3	610	160	305	12	3470	123	5552	15375
EF8 / EFO8	2.4	8	2.59	8.5	1070	280	610	24	8780	310	14048	38750
EF10 / EFO10	3.0	10	3.25	10.7	1670	440	610	24	17790	628	28464	78500
EF12 / EFO12	3.6	12	3.89	12.8	2475	655	610	24	31220	1103	49952	137875

*Increased sump depth may be added to increase sediment storage capacity

** Average density of wet packed sediment in sump = 1.6 kg/L (100 lb/ft³)

Feature	Benefit	Feature Appeals To
Patent-pending enhanced flow treatment and scour prevention technology	Superior, verified third-party performance	Regulator, Specifying & Design Engineer
Third-party verified light liquid capture and retention for EFO version	Proven performance for fuel/oil hotspot locations	Regulator, Specifying & Design Engineer, Site Owner
Functions as bend, junction or inlet structure	Design flexibility	Specifying & Design Engineer
Minimal drop between inlet and outlet	Site installation ease	Contractor
Large diameter outlet riser for inspection and maintenance	Easy maintenance access from grade	Maintenance Contractor & Site Owner

STANDARD STORMCEPTOR EF/EFO DRAWINGS

For standard details, please visit <http://www.imbriumsystems.com/stormwater-treatment-solutions/stormceptor-ef>

STANDARD STORMCEPTOR EF/EFO SPECIFICATION

For specifications, please visit <http://www.imbriumsystems.com/stormwater-treatment-solutions/stormceptor-ef>

STANDARD PERFORMANCE SPECIFICATION FOR “OIL GRIT SEPARATOR” (OGS) STORMWATER QUALITY TREATMENT DEVICE

PART 1 – GENERAL

1.1 WORK INCLUDED

This section specifies requirements for selecting, sizing, and designing an underground Oil Grit Separator (OGS) device for stormwater quality treatment, with third-party testing results and a Statement of Verification in accordance with ISO 14034 Environmental Management – Environmental Technology Verification (ETV).

1.2 REFERENCE STANDARDS & PROCEDURES

ISO 14034:2016 Environmental management – Environmental technology verification (ETV)

Canadian Environmental Technology Verification (ETV) Program’s **Procedure for Laboratory Testing of Oil-Grit Separators**

1.3 SUBMITTALS

1.3.1 All submittals, including sizing reports & shop drawings, shall be submitted upon request with each order to the contractor then forwarded to the Engineer of Record for review and acceptance. Shop drawings shall detail all OGS components, elevations, and sequence of construction.

1.3.2 Alternative devices shall have features identical to or greater than the specified device, including: treatment chamber diameter, treatment chamber wet volume, sediment storage volume, and oil storage volume.

1.3.3 Unless directed otherwise by the Engineer of Record, OGS stormwater quality treatment product substitutions or alternatives submitted within ten days prior to project bid shall not be accepted. All alternatives or substitutions submitted shall be signed and sealed by a local registered Professional Engineer, based on the exact same criteria detailed in Section 3, in entirety, subject to review and approval by the Engineer of Record.

PART 2 – PRODUCTS

2.1 OGS POLLUTANT STORAGE

The OGS device shall include a sump for sediment storage, and a protected volume for the capture and storage of petroleum hydrocarbons and buoyant gross pollutants. The minimum sediment & petroleum hydrocarbon storage capacity shall be as follows:

2.1.1	4 ft (1219 mm) Diameter OGS Units:	1.19 m ³ sediment / 265 L oil
	5 ft (1524 mm) Diameter OGS Units:	1.95 m ³ sediment / 420 L oil
	6 ft (1829 mm) Diameter OGS Units:	3.48 m ³ sediment / 609 L oil
	8 ft (2438 mm) Diameter OGS Units:	8.78 m ³ sediment / 1,071 L oil
	10 ft (3048 mm) Diameter OGS Units:	17.78 m ³ sediment / 1,673 L oil
	12 ft (3657 mm) Diameter OGS Units:	31.23 m ³ sediment / 2,476 L oil

PART 3 – PERFORMANCE & DESIGN

Stormceptor® EF Sizing Report

3.1 GENERAL

The OGS stormwater quality treatment device shall be verified in accordance with ISO 14034:2016 Environmental management – Environmental technology verification (ETV). The OGS stormwater quality treatment device shall remove oil, sediment and gross pollutants from stormwater runoff during frequent wet weather events, and retain these pollutants during less frequent high flow wet weather events below the insert within the OGS for later removal during maintenance. The Manufacturer shall have at least ten (10) years of local experience, history and success in engineering design, manufacturing and production and supply of OGS stormwater quality treatment device systems, acceptable to the Engineer of Record.

3.2 SIZING METHODOLOGY

The OGS device shall be engineered, designed and sized to provide stormwater quality treatment based on treating a minimum of 90 percent of the average annual runoff volume and a minimum removal of an annual average 60% of the sediment (TSS) load based on the Particle Size Distribution (PSD) specified in the sizing report for the specified device. Sizing of the OGS shall be determined by use of a minimum ten (10) years of local historical rainfall data provided by Environment Canada. Sizing shall also be determined by use of the sediment removal performance data derived from the ISO 14034 ETV third-party verified laboratory testing data from testing conducted in accordance with the Canadian ETV protocol Procedure for Laboratory Testing of Oil-Grit Separators, as follows:

3.2.1 Sediment removal efficiency for a given surface loading rate and its associated flow rate shall be based on sediment removal efficiency demonstrated at the seven (7) tested surface loading rates specified in the protocol, ranging 40 L/min/m² to 1400 L/min/m², and as stated in the ISO 14034 ETV Verification Statement for the OGS device.

3.2.2 Sediment removal efficiency for surface loading rates between 40 L/min/m² and 1400 L/min/m² shall be based on linear interpolation of data between consecutive tested surface loading rates.

3.2.3 Sediment removal efficiency for surface loading rates less than the lowest tested surface loading rate of 40 L/min/m² shall be assumed to be identical to the sediment removal efficiency at 40 L/min/m². No extrapolation shall be allowed that results in a sediment removal efficiency that is greater than that demonstrated at 40 L/min/m².

3.2.4 Sediment removal efficiency for surface loading rates greater than the highest tested surface loading rate of 1400 L/min/m² shall assume zero sediment removal for the portion of flow that exceeds 1400 L/min/m², and shall be calculated using a simple proportioning formula, with 1400 L/min/m² in the numerator and the higher surface loading rate in the denominator, and multiplying the resulting fraction times the sediment removal efficiency at 1400 L/min/m².

The OGS device shall also have sufficient annual sediment storage capacity as specified and calculated in Section 2.1.

3.3 CANADIAN ETV or ISO 14034 ETV VERIFICATION OF SCOUR TESTING

The OGS device shall have Canadian ETV or ISO 14034 ETV Verification of third-party scour testing conducted in accordance with the Canadian ETV Program's **Procedure for Laboratory Testing of Oil-Grit Separators**.

3.3.1 To be acceptable for on-line installation, the OGS device must demonstrate an average scour test effluent concentration less than 10 mg/L at each surface loading rate tested, up to and including 2600 L/min/m².

3.4 LIGHT LIQUID RE-ENTRAINMENT SIMULATION TESTING

The OGS device shall have Canadian ETV or ISO 14034 ETV Verification of completed third-party Light Liquid

Stormceptor® EF Sizing Report

Re-entrainment Simulation Testing in accordance with the Canadian ETV **Program's Procedure for Laboratory Testing of Oil-Grit Separators**, with results reported within the Canadian ETV or ISO 14034 ETV verification. This re-entrainment testing is conducted with the device pre-loaded with low density polyethylene (LDPE) plastic beads as a surrogate for light liquids such as oil and fuel. Testing is conducted on the same OGS unit tested for sediment removal to assess whether light liquids captured after a spill are effectively retained at high flow rates.

3.4.1 For an OGS device to be an acceptable stormwater treatment device on a site where vehicular traffic occurs and the potential for an oil or fuel spill exists, the OGS device must have reported verified performance results of greater than 99% cumulative retention of LDPE plastic beads for the five specified surface loading rates (ranging 200 L/min/m² to 2600 L/min/m²) in accordance with the Light Liquid Re-entrainment Simulation Testing within the Canadian ETV Program's **Procedure for Laboratory Testing of Oil-Grit Separators**. However, an OGS device shall not be allowed if the Light Liquid Re-entrainment Simulation Testing was performed with screening components within the OGS device that are effective at retaining the LDPE plastic beads, but would not be expected to retain light liquids such as oil and fuel.

Inlet Control Device

The IPEX Inlet Control Device (ICD) is used to control flow into storm sewers during peak flow events.



It is designed to allow a specified flow volume out of a catchbasin at a specified head. This causes the excess stormwater to be temporarily stored above ground. This approach conserves pipe capacity so that catchbasins upstream do not become uncontrollably surcharged, which could lead to flooding. IPEX ICD's incorporate a special design that prevents clogging, particularly during low flow conditions. IPEX ICDs can also be fabricated to fit any type of pipe – PVC, concrete, clay or a host of other products.

ADVANTAGES

- Controls flow into storm sewers during peak flow events.
- Designed to allow a specified flow volume out of a catchbasin at a specified head.
- Conserves pipe capacity so that catchbasins upstream do not become uncontrollably surcharged, which could lead to flooding.
- Special design that prevents clogging, which can be a problem for some orifice plates, particularly during low flow conditions.



ICDS FOR STORMWATER SYSTEMS

PRODUCT INFORMATION BULLETIN

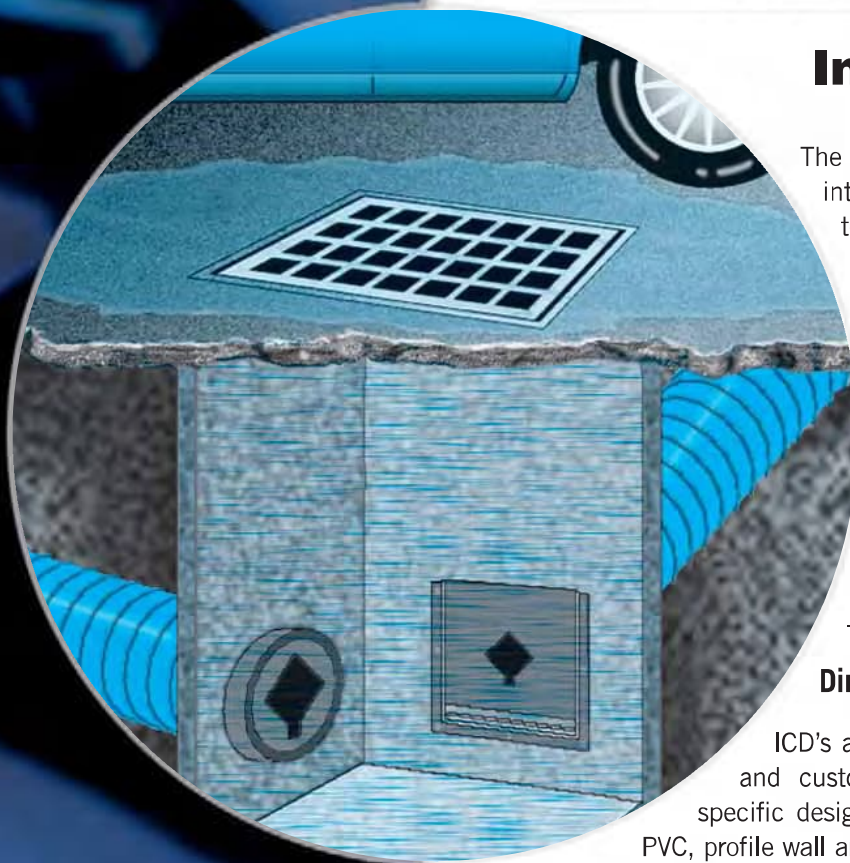

Inlet Control Device

The IPEX Inlet Control Device (ICD) is used to control flow into storm sewers during peak flow events. It is designed to allow a specified flow volume out of a catchbasin at a specified head. This causes the excess stormwater to be temporarily stored above ground. This approach conserves pipe capacity so that catchbasins upstream do not become uncontrollably surcharged, which could lead to flooding.

IPEX ICD's incorporate a special design that prevents clogging, particularly during low flow conditions.

IPEX ICDs can also be fabricated to fit any type of pipe – PVC, concrete, clay or a host of other products.

Dimensions

ICD's are available both as standard (Types A, B, C, D, & F) and custom designed configurations. In addition, there are specific designs for different types of pipe, including smooth wall PVC, profile wall and concrete pipe.

The main advantage of specifying standard ICD's is that they are readily available and can be delivered immediately. However, there are definite advantages to specifying custom sized units as they allow tremendous design flexibility because the allowable flow can be matched directly to the topography of the pavement surface.

Applications & Benefits

Storm water flow control for:

- parking lots
- roads
- where main line storm sewer capacity must be managed
- alleviates basement flooding

Types Available

'Plug' ICD

A short, slightly tapered plug is inserted in the outlet pipe from the catchbasin. Held in place by friction and hydrostatic pressure, plug ICDs are made to fit 200mm, 250mm and 3mm (8", 10" & 12") pipe made from any material (i.e. PVC, concrete, clay, etc.). The orifice plate sits flush with the inside of the catchbasin.



'Framed' ICD

A plate containing the orifice is held in channels in the frame. The ICD frame is bolted over the outlet pipe inside the catchbasin. Framed ICDs can be fabricated for any size and type of pipe.



Products are manufactured by IPEX Inc.
and distributed in the United States by IPEX USA LLC.

Canadian Customers call IPEX Inc.
Toll Free: (866) 473-9462
www.ipexinc.com

US Customers call IPEX USA LLC
Toll Free: (800) 463-9572
www.ipexamerica.com

Sump Scouring Action

The rectangular slot at the bottom of the orifice works effectively in two ways. First, during dry periods it draws the water level below the main orifice area, keeping it clear of floating debris. Second, it generates strong vortex action in the approach flow during heavy rainfalls, vigorously scouring sediment from the sump of the catchbasin.

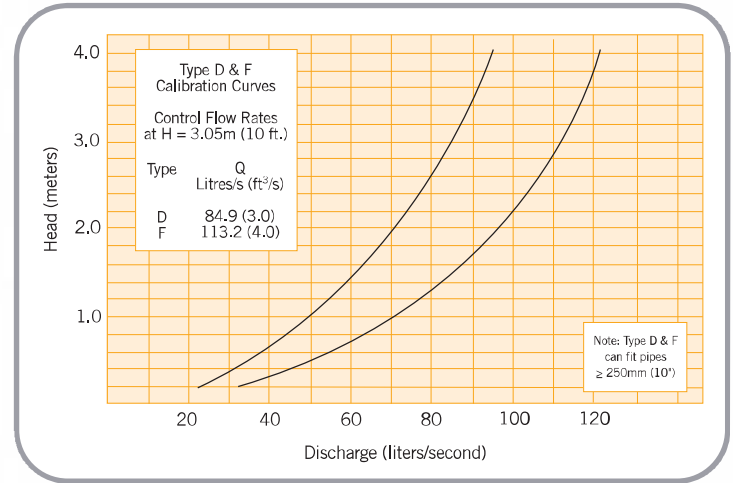
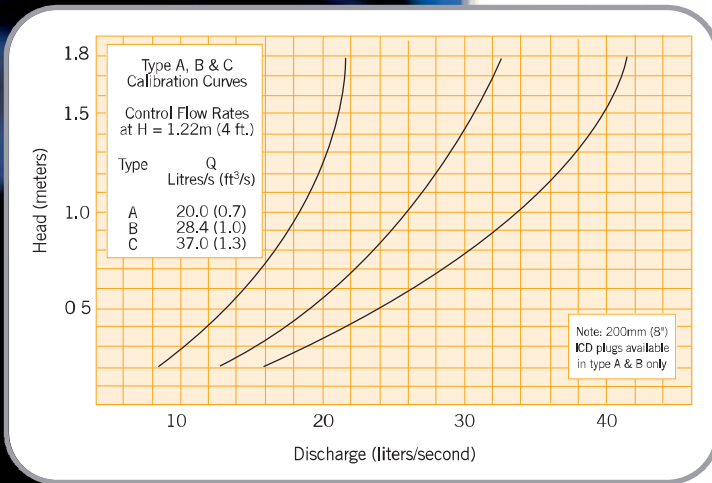

Specifications

IPEX Inlet Control Devices are manufactured from Polyvinyl Chloride (PVC) to be supplied according to the type (i.e. A, B, C, D, or F) as shown in the above graphs.

IPEX Plug ICDs are to be machined to provide a friction fit into the outlet pipe.

Framed ICDs are to be bolted in position over appropriate outlet pipe in the catchbasin/maintenance hole.

Note: IPEX can also design and fabricate I.C.D's with custom curves, in order to match specific site requirements.

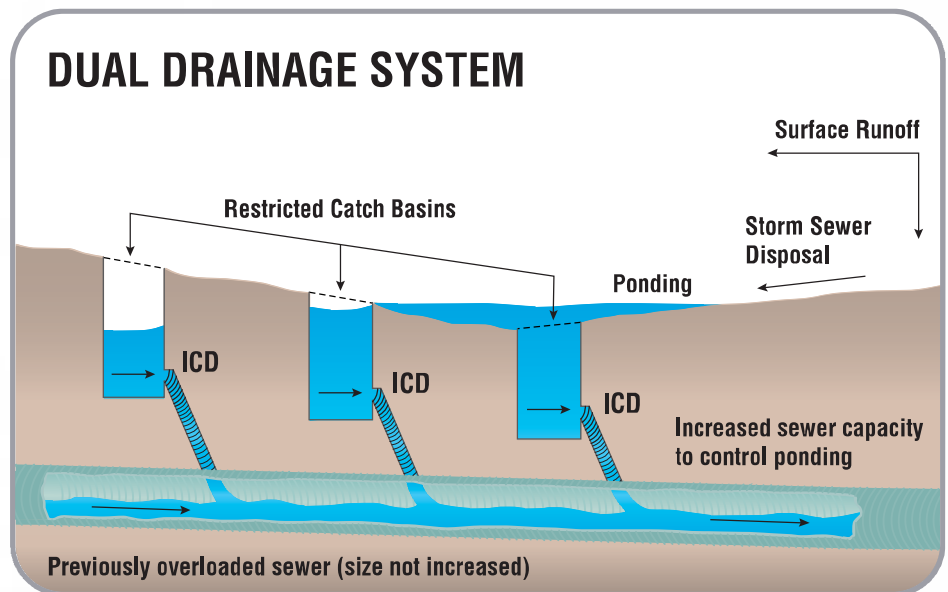

Canadian Customers call IPEX Inc.
Toll Free: (866) 473-9462
www.ipexinc.com

US Customers call IPEX USA LLC
Toll Free: (800) 463-9572
www.ipexamerica.com

APPENDIX H
CITY OF OTTAWA DESIGN CHECKLIST



4. Development Servicing Study Checklist

The following section describes the checklist of the required content of servicing studies. It is expected that the proponent will address each one of the following items for the study to be deemed complete and ready for review by City of Ottawa Infrastructure Approvals staff.

The level of required detail in the Servicing Study will increase depending on the type of application. For example, for Official Plan amendments and re-zoning applications, the main issues will be to determine the capacity requirements for the proposed change in land use and confirm this against the existing capacity constraint, and to define the solutions, phasing of works and the financing of works to address the capacity constraint. For subdivisions and site plans, the above will be required with additional detailed information supporting the servicing within the development boundary.

4.1 General Content

Criteria	Location (if applicable)
<input type="checkbox"/> Executive Summary (for larger reports only).	N/A
<input type="checkbox"/> Date and revision number of the report.	On Cover
<input type="checkbox"/> Location map and plan showing municipal address, boundary, and layout of proposed development.	Appendix A
<input type="checkbox"/> Plan showing the site and location of all existing services.	N/A
<input type="checkbox"/> Development statistics, land use, density, adherence to zoning and official plan, and reference to applicable subwatershed and watershed plans that provide context to which individual developments must adhere.	1.1 Purpose 1.2 Site Description 6.0 Storm Sewer Design
<input type="checkbox"/> Summary of pre-consultation meetings with City and other approval agencies.	Appendix B
<input type="checkbox"/> Reference and confirm conformance to higher level studies and reports (Master Servicing Studies, Environmental Assessments, Community Design Plans), or in the case where it is not in conformance, the proponent must provide justification and develop a defensible design criteria.	1.1 Purpose 1.2 Site Description 6.0 Storm Sewer Design
<input type="checkbox"/> Statement of objectives and servicing criteria.	3.0 Pre-Consultation Summary

<input type="checkbox"/> Identification of existing and proposed infrastructure available in the immediate area.	N/A
<input type="checkbox"/> Identification of Environmentally Significant Areas, watercourses and Municipal Drains potentially impacted by the proposed development (Reference can be made to the Natural Heritage Studies, if available).	N/A
<input type="checkbox"/> Concept level master grading plan to confirm existing and proposed grades in the development. This is required to confirm the feasibility of proposed stormwater management and drainage, soil removal and fill constraints, and potential impacts to neighbouring properties. This is also required to confirm that the proposed grading will not impede existing major system flow paths.	N/A
<input type="checkbox"/> Identification of potential impacts of proposed piped services on private services (such as wells and septic fields on adjacent lands) and mitigation required to address potential impacts.	N/A
<input type="checkbox"/> Proposed phasing of the development, if applicable.	N/A
<input type="checkbox"/> Reference to geotechnical studies and recommendations concerning servicing.	N/A
<input type="checkbox"/> All preliminary and formal site plan submissions should have the following information: <ul style="list-style-type: none"> ○ Metric scale ○ North arrow (including construction North) ○ Key plan ○ Name and contact information of applicant and property owner ○ Property limits including bearings and dimensions ○ Existing and proposed structures and parking areas ○ Easements, road widening and rights-of-way ○ Adjacent street names 	N/A

4.2 Development Servicing Report: Water

Criteria	Location (if applicable)
<input type="checkbox"/> Confirm consistency with Master Servicing Study, if available	N/A
<input type="checkbox"/> Availability of public infrastructure to service proposed development	N/A
<input type="checkbox"/> Identification of system constraints	N/A
<input type="checkbox"/> Identify boundary conditions	Appendix C
<input type="checkbox"/> Confirmation of adequate domestic supply and pressure	N/A
<input type="checkbox"/> Confirmation of adequate fire flow protection and confirmation that fire flow is calculated as per the Fire Underwriter's Survey. Output should show available fire flow at locations throughout the development.	Appendix C
<input type="checkbox"/> Provide a check of high pressures. If pressure is found to be high, an assessment is required to confirm the application of pressure reducing valves.	N/A
<input type="checkbox"/> Definition of phasing constraints. Hydraulic modeling is required to confirm servicing for all defined phases of the project including the ultimate design	N/A
<input type="checkbox"/> Address reliability requirements such as appropriate location of shut-off valves	N/A
<input type="checkbox"/> Check on the necessity of a pressure zone boundary modification.	N/A
<input type="checkbox"/> Reference to water supply analysis to show that major infrastructure is capable of delivering sufficient water for the proposed land use. This includes data that shows that the expected demands under average day, peak hour and fire flow conditions provide water within the required pressure range	Appendix C, Section 4.2 Proposed Water Servicing

<input type="checkbox"/> Description of the proposed water distribution network, including locations of proposed connections to the existing system, provisions for necessary looping, and appurtenances (valves, pressure reducing valves, valve chambers, and fire hydrants) including special metering provisions.	Site Servicing Plan (C101)
<input type="checkbox"/> Description of off-site required feeder mains, booster pumping stations, and other water infrastructure that will be ultimately required to service proposed development, including financing, interim facilities, and timing of implementation.	N/A
<input type="checkbox"/> Confirmation that water demands are calculated based on the City of Ottawa Design Guidelines.	Appendix C
<input type="checkbox"/> Provision of a model schematic showing the boundary conditions locations, streets, parcels, and building locations for reference.	N/A

4.3 Development Servicing Report: Wastewater

Criteria	Location (if applicable)
<input type="checkbox"/> Summary of proposed design criteria (Note: Wet-weather flow criteria should not deviate from the City of Ottawa Sewer Design Guidelines. Monitored flow data from relatively new infrastructure cannot be used to justify capacity requirements for proposed infrastructure).	N/A
<input type="checkbox"/> Confirm consistency with Master Servicing Study and/or justifications for deviations.	N/A
<input type="checkbox"/> Consideration of local conditions that may contribute to extraneous flows that are higher than the recommended flows in the guidelines. This includes groundwater and soil conditions, and age and condition of sewers.	N/A
<input type="checkbox"/> Description of existing sanitary sewer available for discharge of wastewater from proposed development.	Section 5.2 Proposed Sanitary Servicing

<input type="checkbox"/> Verify available capacity in downstream sanitary sewer and/or identification of upgrades necessary to service the proposed development. (Reference can be made to previously completed Master Servicing Study if applicable)	Section 5.2 Proposed Sanitary Servicing
<input type="checkbox"/> Calculations related to dry-weather and wet-weather flow rates from the development in standard MOE sanitary sewer design table (Appendix 'C') format.	N/A
<input type="checkbox"/> Description of proposed sewer network including sewers, pumping stations, and forcemains.	Section 5.2 Proposed Sanitary Servicing
<input type="checkbox"/> Discussion of previously identified environmental constraints and impact on servicing (environmental constraints are related to limitations imposed on the development in order to preserve the physical condition of watercourses, vegetation, soil cover, as well as protecting against water quantity and quality).	N/A
<input type="checkbox"/> Pumping stations: impacts of proposed development on existing pumping stations or requirements for new pumping station to service development.	N/A
<input type="checkbox"/> Forcemain capacity in terms of operational redundancy, surge pressure and maximum flow velocity.	N/A
<input type="checkbox"/> Identification and implementation of the emergency overflow from sanitary pumping stations in relation to the hydraulic grade line to protect against basement flooding.	N/A
<input type="checkbox"/> Special considerations such as contamination, corrosive environment etc.	N/A

4.4 Development Servicing Report: Stormwater Checklist

Criteria	Location (if applicable)
<input type="checkbox"/> Description of drainage outlets and downstream constraints including legality of outlets (i.e. municipal drain, right-of-way, watercourse, or private property)	Section 6.0 Storm Sewer Servicing & Section 7.0 Proposed Stormwater Management
<input type="checkbox"/> Analysis of available capacity in existing public infrastructure.	N/A
<input type="checkbox"/> A drawing showing the subject lands, its surroundings, the receiving watercourse, existing drainage patterns, and proposed drainage pattern.	Pre & Post-Development Plans
<input type="checkbox"/> Water quantity control objective (e.g. controlling post-development peak flows to pre-development level for storm events ranging from the 2 or 5-year event (dependent on the receiving sewer design) to 100-year return period); if other objectives are being applied, a rationale must be included with reference to hydrologic analyses of the potentially affected subwatersheds, taking into account long-term cumulative effects.	Section 6.0 Storm Sewer Servicing & Section 7.0 Proposed Stormwater Management
<input type="checkbox"/> Water Quality control objective (basic, normal or enhanced level of protection based on the sensitivities of the receiving watercourse) and storage requirements.	Section 6.0 Storm Sewer Servicing & Section 7.0 Proposed Stormwater Management
<input type="checkbox"/> Description of the stormwater management concept with facility locations and descriptions with references and supporting information.	Section 6.0 Storm Sewer Servicing & Section 7.0 Proposed Stormwater Management
<input type="checkbox"/> Set-back from private sewage disposal systems.	N/A
<input type="checkbox"/> Watercourse and hazard lands setbacks.	N/A
<input type="checkbox"/> Record of pre-consultation with the Ontario Ministry of Environment and the Conservation Authority that has jurisdiction on the affected watershed.	N/A
<input type="checkbox"/> Confirm consistency with sub-watershed and Master Servicing Study, if applicable study exists.	N/A
<input type="checkbox"/> Storage requirements (complete with calculations) and conveyance capacity for minor events (1:5-year return period) and major events (1:100-year return period).	Appendix G

<input type="checkbox"/> Identification of watercourses within the proposed development and how watercourses will be protected, or, if necessary, altered by the proposed development with applicable approvals.	Site Grading Plan (C101)
<input type="checkbox"/> Calculate pre-and post development peak flow rates including a description of existing site conditions and proposed impervious areas and drainage catchments in comparison to existing conditions.	Appendix G, Section 7.0 Proposed Stormwater Management
<input type="checkbox"/> Any proposed diversion of drainage catchment areas from one outlet to another.	Section 6.0 Storm Sewer Servicing & Section 7.0 Proposed Stormwater Management
<input type="checkbox"/> Proposed minor and major systems including locations and sizes of stormwater trunk sewers, and stormwater management facilities.	Section 6.0 Storm Sewer Servicing & Section 7.0 Proposed Stormwater Management
<input type="checkbox"/> If quantity control is not proposed, demonstration that downstream system has adequate capacity for the post-development flows up to and including the 100-year return period storm event.	N/A
<input type="checkbox"/> Identification of potential impacts to receiving watercourses	N/A
<input type="checkbox"/> Identification of municipal drains and related approval requirements.	N/A
<input type="checkbox"/> Descriptions of how the conveyance and storage capacity will be achieved for the development.	Section 6.0 Storm Sewer Servicing & Section 7.0 Proposed Stormwater Management
<input type="checkbox"/> 100-year flood levels and major flow routing to protect proposed development from flooding for establishing minimum building elevations (MBE) and overall grading.	Site Grading Plan (C101)
<input type="checkbox"/> Inclusion of hydraulic analysis including hydraulic grade line elevations.	N/A

<input type="checkbox"/> Description of approach to erosion and sediment control during construction for the protection of receiving watercourse or drainage corridors.	Section 8.0 Sediment & Erosion Control
<input type="checkbox"/> Identification of floodplains – proponent to obtain relevant floodplain information from the appropriate Conservation Authority. The proponent may be required to delineate floodplain elevations to the satisfaction of the Conservation Authority if such information is not available or if information does not match current conditions.	N/A
<input type="checkbox"/> Identification of fill constraints related to floodplain and geotechnical investigation.	N/A

4.5 Approval and Permit Requirements: Checklist

The Servicing Study shall provide a list of applicable permits and regulatory approvals necessary for the proposed development as well as the relevant issues affecting each approval. The approval and permitting shall include but not be limited to the following:

Criteria	Location (if applicable)
<input type="checkbox"/> Conservation Authority as the designated approval agency for modification of floodplain, potential impact on fish habitat, proposed works in or adjacent to a watercourse, cut/fill permits and Approval under Lakes and Rivers Improvement Act. The Conservation Authority is not the approval authority for the Lakes and Rivers Improvement Act. Where there are Conservation Authority regulations in place, approval under the Lakes and Rivers Improvement Act is not required, except in cases of dams as defined in the Act.	N/A
<input type="checkbox"/> Application for Certificate of Approval (CofA) under the Ontario Water Resources Act.	N/A
<input type="checkbox"/> Changes to Municipal Drains.	N/A
<input type="checkbox"/> Other permits (National Capital Commission, Parks Canada, Public Works and Government Services Canada, Ministry of Transportation etc.)	N/A

4.6 Conclusion Checklist

Criteria	Location (if applicable)
<input type="checkbox"/> Clearly stated conclusions and recommendations	Section 9.0 Summary Section 10.0 Recommendations
<input type="checkbox"/> Comments received from review agencies including the City of Ottawa and information on how the comments were addressed. Final sign-off from the responsible reviewing agency.	All are stamped
<input type="checkbox"/> All draft and final reports shall be signed and stamped by a professional Engineer registered in Ontario	All are stamped