

Acoustic Assessment Report – Evolugen South March Battery Energy Storage Project

FINAL REPORT

October 15, 2025

Prepared for:
Evolugen
243 Industrial Park Crescent
Sault Ste. Marie ON P7B 5P3

Prepared by:
Stantec Consulting Ltd.

Project/File:
160930481



Limitations and Sign-off

The conclusions in the Report titled Acoustic Assessment Report – Evolgen South March Battery Energy Storage Project are Stantec’s professional opinion, as of the time of the Report, and concerning the scope described in the Report. The opinions in the document are based on conditions and information existing at the time the scope of work was conducted and do not take into account any subsequent changes. The Report relates solely to the specific project for which Stantec was retained and the stated purpose for which the Report was prepared. The Report is not to be used or relied on for any variation or extension of the project, or for any other project or purpose, and any unauthorized use or reliance is at the recipient’s own risk.

Stantec has assumed all information received from Evolgen (the “Client”) and third parties in the preparation of the Report to be correct. While Stantec has exercised a customary level of judgment or due diligence in the use of such information, Stantec assumes no responsibility for the consequences of any error or omission contained therein.

This Report is intended solely for use by the Client in accordance with Stantec’s contract with the Client. While the Report may be provided to applicable authorities having jurisdiction and others for whom the Client is responsible, Stantec does not warrant the services to any third party. The report may not be relied upon by any other party without the express written consent of Stantec, which may be withheld at Stantec’s discretion.



Digitally signed
by Alvarado,
Fabian
Date:
2025.10.15
15:43:46 -04'00'

Prepared by:

Signature

Fabian Alvarado, M.Eng., P.Eng.
Noise and Acoustics Engineer

Printed Name and Title

A handwritten signature in black ink, appearing to read "Mohammed Salim". A red digital signature is written over it.

Digitally signed by
Salim, Mohammed
Date: 2025.10.16
08:29:38 -04'00'

Reviewed by:

Signature

Mohammed Salim, MBA, P.Eng.
Associate, Senior Acoustical Engineer

Printed Name and Title



Executive Summary

Stantec Consulting Ltd. (Stantec) was retained by Evolgen to prepare an acoustic assessment report (AAR) in support of the Transmission Facility Class Environmental Assessment (TF Class EA) of the proposed 250 MW South March Battery Energy Storage System (BESS) in Ottawa, Ontario (the Facility). This AAR is based on the Facility site drawing “7154023-100000-41-D20-0001 Rev AH” prepared by BBA and dated October 7, 2025 (see Appendix A).

The North American Industry Classification System (NAICS) code for the Project is anticipated to be 2211221 – Electric Bulk Power Transmission and Control. Based on the Project NAICS code and nature of operations, it is expected to be eligible for registration under the Ontario Ministry of the Environment Conservation and Parks (MECP) Environmental Activity Sector Registry (EASR). Therefore, this AAR has been prepared in accordance with the following MECP publications:

- Chapter 3 of the “Environmental Activity and Sector Registry – Limits and Other Requirements” (MECP 2021a)
- Section 16 of the *Environmental Protection Act* Ontario Regulation 1/17: Registrations under Part II.2 of The Act – Activities requiring Assessment of Air Emissions (MECP 2021b)

The purpose of the AAR is to assess compliance of the Facility noise levels with the applicable noise limits set out in Chapter 3 of the publication “Environmental Activity and Sector Registry – Limits and Other Requirements” (EASR publication) at representative points of reception.

Facility noise sources and operating conditions were identified from site plans and equipment information provided by Evolgen. Sound power levels and operating conditions for Facility noise sources were used as inputs in a predictive acoustic model developed using Cadna/A (Datakustik GmbH 2025), a noise modelling software configured to implement ISO 9613-2 environmental sound propagation algorithms (ISO 1996). The assessment models the Facility’s regular operations with the identified noise sources operating during a predictable worst-case hour during the day, evening, and nighttime periods. Routine emergency generator testing is assessed separately, in accordance with MECP guidelines.

Nine (9) representative points of reception (PORs), consisting of local residential dwellings and an accessible vacant lot receptor, have been identified for this assessment. Although MECP guidelines exclusively consider off-site noise sensitive land uses as qualifying receptors, this assessment includes an on-site dwelling located at 2625 Marchurst Road as a discretionary receptor.



For the Facility regular operations, predicted noise levels comply with the applicable MECP limits at the modelled PORs, provided the Facility noise sources, including the main power transformers, do not exceed the sound power levels considered in this assessment. Further, all BESS units must be equipped with manufacturer-supplied noise reduction kits, and the noise walls/berms must be implemented as shown in the site plan (see Appendix A). The noise walls must be of solid construction without any gaps, have a surface density of 20 kg/m², and conform to the overall heights and extents considered in this assessment. No additional noise control measures are required for the Facility's regular operations to demonstrate compliance with MECP noise limits.

For emergency generator testing, predicted noise levels comply with the applicable MECP noise limits at all modelled PORs. As such, no additional mitigation measures are anticipated, provided generator sound power level does not exceed that considered in this assessment.

If there are changes to the Facility such as equipment manufacturer/model, sound levels, operating conditions, and layout, the acoustic assessment should be updated to confirm compliance with MECP noise limits and identify any additional noise controls, if required.

The Facility's operations are not considered significant sources of vibration. Based on equipment type and operational characteristics, vibration impacts are deemed negligible. Therefore, a vibration assessment is not included in this AAR.



Table of Contents

1	Introduction	1
2	Facility Description	2
3	Noise Sources	3
3.1	Insignificant Noise Sources	5
4	Points of Reception	6
5	Assessment Criteria	8
6	Impact Assessment	9
6.1	Methods	9
6.2	Modelling Scenarios	9
6.3	Results	10
	6.3.1 Regular Operations	10
	6.3.2 Emergency Generator Testing	14
7	Conclusion and Closure	20
8	References	21

List of Tables

Table 3.1	Noise Source Summary	4
Table 4.1	Points of Reception Summary	6
Table 5.1	EASR Publication Noise Limits for Class 3 Area	8
Table 6.1	Key Acoustic Model Parameters	9
Table 6.2	Modelled Operating Scenarios	10
Table 6.3	Acoustic Assessment Summary – Regular Operations	11
Table 6.4	Acoustic Assessment Summary – Emergency Generator Testing	15

List of Appendices

Appendix A Facility Drawings

Appendix B Figures

- Figure 1 Facility Location and Points of Reception
- Figure 2 Modelled Noise Sources
- Figure 3 Equivalent Noise Level Contours – Regular Operations
- Figure 4 Equivalent Noise Level Contours – Emergency Generator Testing

Appendix C Zoning Map

Appendix D Manufacturer and Spectral Sound Level Data

Appendix E Impact Assessment Tables

- Table E. 1 Noise Impact Summary – Regular Operations
- Table E. 2 Noise Impact Summary – Emergency Generator Testing

Appendix F Acoustic Model Sample Calculations



Acronyms / Abbreviations

AAR	Acoustic Assessment Report
BESS	Battery Energy Storage System
Class EA	Class Environmental Assessment
dB	Decibel
dBA	Decibel, A-weighted
EASR	Environmental Activity Sector Registry
EPA	Environmental Protection Act
HVAC	Heating, Ventilation and Air-conditioning
Hydro One	Hydro One Network Inc.
Hz	Hertz
ISO	International Organization for Standardization
LiDAR	Light Detection and Ranging
m	Meter(s)
MECP	Ontario Ministry of the Environment, Conservation and Parks (formerly MOE and MOECC)
MOE	Ontario Ministry of the Environment
MOECC	Ontario Ministry of the Environment and Climate Change
MPT	Main Power Transformer
MVS	Medium Voltage Substation
NAICS	North American Industry Classification System
NPC	Noise Pollution Control Guideline - Ontario
OPOR	Outdoor Point of Reception
O.Reg.	Ontario Regulation
POR	Point of Reception
Stantec	Stantec Consulting Ltd.
TF	Transmission Facilities



Glossary

Term	Definition
Ambient Sound Level or Ambient Noise	All-encompassing sound that is associated with a given environment, usually a composite of sounds from many sources near and far. Includes noise from all sources other than the sources of interest (i.e., sound other than that being measured), such as sound from other industrial sources, transportation sources, animals and nature.
A-Weighting	The weighting network used to account for changes in level sensitivity as a function of frequency. The A-weighting network de-emphasizes the low (i.e., below 1 kHz) frequencies, and emphasizes the frequencies between 1 kHz and 6.3 kHz, in an effort to simulate the relative response of the human ear. See also frequency weighting.
Background Sound Level or Background Noise	Same as the ambient sound level.
Daytime	Defined as the hours from 07:00 to 19:00
Decibel	A logarithmic measure of any measured physical quantity and commonly used in the measurement of sound. The decibel (dB) provides the possibility of representing a large span of signal levels in a simple manner. The difference between the sound pressure for silenced versus a loud sound is a factor of 1:1,000,000 or more and the same in Decibel is 0-130 dB, therefore it is less cumbersome to use a small range of equivalent values. A tenfold increase in sound power is equal to +10 dB; a tenfold increase in sound amplitude is equal to +20 dB.
Decibel, A-weighted	A-weighted decibels (dBA). Most common units for expressing sound levels since they approximate the response of the human ear.
Energy Equivalent Sound Level (L_{eq})	An energy-equivalent sound level (L_{eq}) over a specified period of time that would have the same sound energy as the actual (i.e., unsteady) time varying sound over the same period of time. It represents the average sound pressure encountered for the period. The period is often added as a suffix to the label (i.e., L_{eq-1hr} for the 1 hour equivalent sound level). A L_{eq} value expressed in dBA is a good, single value descriptor to use as a measure of annoyance due to noise.



Acoustic Assessment Report – Evolgen South March Battery Energy Storage Project

Glossary

October 15, 2025

Term	Definition
Evening	Defined as the hours from 19:00 to 23:00
Frequency	The number of times per second that the sine wave of sound repeats itself. It can be expressed in cycles per second, or Hertz (Hz).
Frequency Weighting	A method used to account for changes in sensitivity as a function of frequency. Three standard weightings, A, B, and C are used to account for different responses to sound pressure levels. Note: The absence of frequency weighting is referred to as “flat” response or linear weighting. See also A-weighting.
Ground Absorption Coefficient	A parameter defined based on noise reflection characteristics of a surface. It varies between 0.0 (fully reflective) to 1.0 (fully absorptive).
Hertz (Hz)	The unit of frequency also expressed as cycles per second.
International Organization for Standardization	An international body that provides scientific standards and guidelines related to various technical subjects and disciplines.
Mitigation	Measures taken to reduce, eliminate, or control impacts on the environment.
Nighttime	Defined as the hours from 23:00 to 07:00
Noise	Any unwanted sound. “Noise” and “sound” are used interchangeably in this document.
Octave	The interval between two frequencies having a ratio of two to one. In acoustic measurements, the octave bands typically start at a centre frequency of 1,000 Hz and progress upward or downward by doubling or halving the frequency. For example, from 1,000 Hz, the next higher centre frequency is 2,000 Hz, followed by 4,000 Hz; or the frequency continues in the lower direction with 500 Hz, 250 Hz, and so on.
Point of Reception	A representative point considered for the purpose of assessment such as a residence, campground, daycare, school, church, or hospital.
Predictable Worst-Case Operation	A planned and predictable mode of operation for stationary source(s), during the hour when the noise emissions from the stationary source(s) have the greatest impact at a point of reception, relative to the applicable limit.



Acoustic Assessment Report – Evolgen South March Battery Energy Storage Project

Glossary

October 15, 2025

Term	Definition
Sound	A wave motion in air, water, or other media. It is the rapid oscillatory compression changes in a medium that propagate to distant points. It is characterized by changes in density, pressure, motion, and temperature as well as other physical properties. Not all rapid changes in the medium are due to sound (e.g., wind distortion on a microphone diaphragm).
Sound Level	Generally, sound level refers to the weighted sound pressure level obtained by frequency weighting, usually A- or C-weighted, and expressed in decibels
Sound Power Level	The total sound energy radiated by a source per unit time (i.e., rate of acoustical energy radiation). The unit of measurement is the Watt. The acoustic power radiated from a given sound source as related to a reference power level (i.e., typically 1×10^{-12} watts, or 1 picowatt) and expressed as decibels. A sound power level of 1 watt = 120 decibels relative to a reference level of 1 picowatt.
Sound Pressure	The root-mean-square of the instantaneous sound pressures during a specified time interval in a stated frequency band.
Sound Pressure Level	Logarithmic ratio of the root mean square sound pressure to the sound pressure at the threshold of human hearing (i.e., 20 micropascals).
Spectrum (Frequency Spectrum)	The frequency dependent characteristic of sound often expressed as amplitude versus octave band frequency (see octave band).



1 Introduction

Stantec Consulting Ltd. (Stantec) was retained by Evolgen to prepare an acoustic assessment report (AAR) in support of the Transmission Facility Class Environmental Assessment (TF Class EA) of the proposed 250 MW South March Battery Energy Storage System (BESS) in Ottawa, Ontario (the Facility).

The North American Industry Classification System (NAICS) code for the Project is anticipated to be 2211221 – Electric Bulk Power Transmission and Control. Based on the Project NAICS code and nature of operations, it is expected to be eligible for registration under the Ontario Ministry of the Environment Conservation and Parks (MECP) Environmental Activity Sector Registry (EASR). Therefore, this AAR has been completed in accordance with the following MECP publications:

- Chapter 3 of the “Environmental Activity and Sector Registry – Limits and Other Requirements” (MECP 2021a)
- Section 16 of the *Environmental Protection Act* Ontario Regulation 1/17: Registrations under Part II.2 of The Act – Activities requiring Assessment of Air Emissions (MECP 2021b)

The purpose of the AAR is to assess compliance of the Facility noise levels with the applicable noise limits set out in Chapter 3 of the publication “Environmental Activity and Sector Registry – Limits and Other Requirements” (EASR publication) at representative points of reception.

This AAR is based on the Facility site drawing “7154023-100000-41-D20-0001 Rev AH” prepared by BBA and dated October 7, 2025 (see Appendix A).

The Facility’s operations are not considered significant sources of vibration; therefore, a vibration assessment is not included in this AAR.



2 Facility Description

The Facility is located in the southwest corner of Thomas A Dolan Parkway and Marchurst Road in Ottawa, Ontario. The Facility is surrounded by Marchurst Road to the northeast, Thomas A Dolan Parkway to the northwest and Forested area to the west and south, with John Aselford Drive further south.

A map of the Facility property and surrounding area is provided in Appendix B, Figure 1.

The lands surrounding the Facility are predominantly zoned as rural countryside, agricultural, and environmental protection designations under the City of Ottawa Zoning By-law (City of Ottawa 2008), all of which allow for residential dwellings. Nearby dwellings are located along Thomas A Dolan Parkway, Marchurst Road, and John Aselford Drive. A zoning map of the surrounding lands is provided in Appendix C.

The Facility primarily stores electrical energy using large-scale battery systems for later use. It supports grid stability by storing excess electricity during periods of low demand and discharging it when demand is high. Given the nature of its operations, the Facility may operate 24 hours a day, 7 days a week.

As shown in the site plan (see Appendix A), the Facility will include 4.5 m high noise walls for select BESS units and a 6 m high earth berm located at the north end of the site.

The Facility will include a 125 kW propane fueled emergency generator to power the Facility in case of a grid outage. The generator will operate during grid outages and routine maintenance testing.



3 Noise Sources

The noise sources considered in this assessment were identified through a review of the Facility site drawing in Attachment A and equipment information provided by Evolgen. Key equipment information is included in Appendix D. The Facility’s primary noise sources are identified as follows:

- **BESS Units** – Three hundred and seven (307) Sungrow PowerTitan 2.0 BESS operating at 35 degrees Celsius and 80% power conditions. Evolgen has confirmed that all units will be equipped with the manufacturer-supplied noise reduction kits. As shown in Appendix A, 4.5 m high noise walls will be installed along select BESS units.
- **Main Power Transformers (MPTs)** – Two (2) 230 kV MPTs rated up to 175 MVA. The cooling designation for these transformers is oil-filled, forced-air cooling, stage 2 (ONAF2). Evolgen confirmed that each transformer procured for the Facility will not exceed a sound pressure level of 65 dBA at 2 m, per Institute of Electrical and Electronics Engineers (IEEE) Standard Test Code for Liquid-Immersed Distribution, Power, and Regulating Transformers (IEEE 2015).
- **Medium Voltage Substation (MVS)** – Seventy-seven (77) 34.5 kV Sungrow MVS5140 medium voltage substations, each rated at 5 MVA with a non-mineral oil filled, natural convection (KNAN) cooling designation.
- **Heating, Ventilation and Air-conditioning (HVAC) equipment** – One (1) 30-ton HVAC unit assumed for the Facility’s control building, since project-specific HVAC details were not available at the time of this study.
- **Emergency Power Generator** – One (1) 125 kW propane-fueled emergency generator.

A summary of the noise sources considered in this assessment, including their quantities, overall sound power levels, and sound characteristics, is provided in Table 3.1. A map showing the modelled noise sources is provided in Appendix B, Figure 2.



Table 3.1 Noise Source Summary

Quantity	Noise Source Description	Sound Power Level (dBA) ^a	Source Location (I/O) ^b	Sound Characteristics ^c	Noise Control Measures ^d
307	Sungrow PowerTitan 2.0 BESS	79 ^e	O	T	S, B
77	Medium Voltage Substation - 5 MVA	79	O	T	U
2	Main Power Transformers - 175 MVA	89	O	T	U
1	30 Ton HVAC Unit	95	O	S	U
1	125 kW Emergency Generator	100	O	S	E, S ^f

Notes:

- a. Value does not include the tonal sound level adjustment from NPC-104, where applicable.
- b. Source Location: O = Outside of building, I = Inside of building.
- c. Sound Characteristics per NPC-104: T = Tonal, S = Steady
- d. Noise Control Measures: B = Noise Barrier, E = Enclosure, S = Silencer/Muffler, U = Uncontrolled
- e. Values for the BESS reflect a 35 degree Celsius ambient temperature and 80% power operating condition
- f. The emergency generator is assumed to be equipped with an acoustic enclosure, eliminating any tonal components in the sound spectrum



Sound power levels for the BESS and MVS were obtained from manufacturer sound data provided by Evolgen. The MPT sound power level was derived from the sound pressure level specification provided by Evolgen and published sound power level prediction methods from the IEEE (IEEE 2015). Additional sound power levels were referenced from Stantec’s internal database, which includes manufacturer sound data and field measurements of similar equipment. Manufacturer sound data and spectral sound levels used in this assessment are provided in Appendix D.

MECP publication NPC-104 (MOE 1978) prescribes adjustments for sources with special qualities or characters of sound. These are punitive adjustments which apply to noise sources with subjectively annoying characteristics, including tonal sounds, quasi-impulsive sounds and beating sounds (sounds with cyclically varying amplitudes). The BESS and MVS units are considered tonal, as their spectral sound levels meet the tonality criteria outlined in ISO 1996-2:2017 (ISO 2017) . In the absence of spectral data for the MPTs, they are also considered tonal, as transformers typically exhibit tonal characteristics. Accordingly, a +5 dB adjustment was applied to the sound power level of these sources per NPC-104. No other sound power level adjustments were considered in this assessment.

3.1 Insignificant Noise Sources

This assessment considers auxiliary transformers, and small HVAC units and building exhausts as insignificant noise sources, as they are expected to have negligible contributions to the overall Facility noise level, based on their size and noise emission, as well as location relative to the receptor, including line-of-sight considerations.



4 Points of Reception

In accordance with the EASR publication, Facility noise levels are evaluated at points of reception (PORs) located on properties that contain one or more of the following buildings:

- A building or structure that includes one or more dwellings
- A building used for commercial purposes that includes one or more habitable rooms used as sleeping facilities, such as a hotel or motel
- A building used for institutional purposes, including educational facilities, and hospitals
- A building used for a place of worship, except when located on land zoned for commercial or industrial use

Based on a review of aerial imagery and local zoning maps, nine (9) representative PORs were identified for this assessment. The PORs consist of local residential dwellings, including an on-site residence located at 2625 Marchurst Road, and an accessible vacant lot receptor. While MECP guidelines consider off-site noise sensitive land uses as qualifying receptors, this assessment includes the on-site residence as a discretionary receptor. The identified PORs represent the plane of window of noise sensitive spaces (e.g., sleeping quarters) and Outdoor Point of Reception (OPOR).

The PORs considered in this assessment are listed in Table 4.1 and shown in Appendix B, Figure 1.

Table 4.1 Points of Reception Summary

POR ID	POR Description	Modelled Height above ground ^a (m)	MTM Coordinates, NAD83 Zone 9	
			Easting (m)	Northing (m)
POR1	1 Storey Residence - 2807 Stonecrest Road	1.5	339161	5028562
OPOR1	Residence Yard - 2807 Stonecrest Road	1.5	339178	5028545
POR2	2 ^b Storey Residence - 2665 Marchurst Road	4.5	340427	5029048
OPOR2	Residence Yard - 2665 Marchurst Road	1.5	340433	5029017
POR3	3 Storey Residence - 2655 Marchurst Road	7.5 ^c	340566	5029066
OPOR3	Residence Yard - 2655 Marchurst Road	1.5	340573	5029037
POR4	1 Storey Residence - 2620 Marchurst Road	1.5	340922	5028982



Acoustic Assessment Report – Evulgen South March Battery Energy Storage Project
4 Points of Reception
 October 15, 2025

POR ID	POR Description	Modelled Height above ground ^a (m)	MTM Coordinates, NAD83 Zone 9	
			Easting (m)	Northing (m)
OPOR4	Residence Yard - 2620 Marchurst Road	1.5	340902	5028960
POR5	2 Storey Residence - 2475 Marchurst Road	4.5	341261	5028302
OPOR5	Residence Yard - 2475 Marchurst Road	1.5	341243	5028327
POR6	1 Storey Residence - 110 Edith Margaret Place	1.5	340604	5027002
OPOR6	Residence Yard - 110 Edith Margaret Place	1.5	340600	5027031
POR7	2 Storey On-Site Residence - 2625 Marchurst Road (Discretionary Receptor)	4.5	340700	5028838
OPOR7	On-Site Residence Yard - 2625 Marchurst Road (Discretionary Receptor)	1.5	340674	5028823
POR8	1 Storey Residence - 1620 Thomas A. Dolan Parkway	1.5	339947	5029173
OPOR8	Residence Yard - 1620 Thomas A. Dolan Parkway	1.5	339965	5029148
VL1	Accessible Vacant Lot - 2655 Marchurst Road	4.5	340511	5029107

Notes:

- a. The modelled height is set at the plane of window where Facility noise levels are predicted to be the highest relative to the applicable noise level limits:
 - 7.5 m above ground for the Plane of Window PORs for three-storey residences
 - 4.5 m above ground for the Plane of Window PORs for two-storey residences
 - 1.5 m above ground for the Plane of Window PORs for one-storey residences and Outdoor PORs
- b. The number of storeys were assumed for this assessment, as it could not be verified through publicly available imagery
- c. Highest plane of window was assumed for this assessment, as it could not be verified through aerial imagery



5 Assessment Criteria

Chapter 3 of the EASR publication provides the applicable assessment criteria in terms of the one-hour equivalent noise level (L_{eq-1hr}). The applicable noise limits are set as the higher of either the background noise level at the POR or the applicable Class Area noise limit specified in the EASR publication. The Class Area noise limits apply at a POR depending on the characteristics of its acoustic environment and time of day (e.g., daytime, evening, or nighttime).

Based on site observations and a review of local aerial imagery, the local area exhibits characteristics of a Class 3 area, as defined in the EASR publication:

Class 3 Area – An area where the background noise level during the day and night is dominated by natural sounds, with little to no traffic.

The Class 3 Area noise limits from the EASR publication have been used as the assessment criteria and are summarized in Table 5.1.

Table 5.1 EASR Publication Noise Limits for Class 3 Area

Period	Noise Limits, L_{eq-1hr} (dBA)	
	Outdoor POR	Plane of Window POR
Daytime (07:00 to 19:00)	45	45
Evening (19:00 to 23:00)	40	40
Nighttime (23:00 to 07:00)	N/A	40

As per the EASR publication, only the non-emergency operation of emergency equipment is assessed in the AAR (i.e., planned emergency generator testing). Noise levels from emergency equipment testing are assessed separately from the rest of the Facility operations and are compared to noise limits that are 5 dB higher than the otherwise applicable limits.



6 Impact Assessment

6.1 Methods

This assessment to predicts Facility noise levels at the PORs using the commercially available acoustic modelling software Cadna/A (version 2025). The acoustic model was configured to implement ISO 9613-2 (ISO 1996) noise propagation algorithms, which account for noise attenuation effects from distance, intervening structures, atmospheric absorption, ground absorption, and local topography.

The Facility development area ground elevation, including base of the earth berm, was modelled at 101 m above sea level, as advised by Evolgen. Outside of the development area, the ground elevation was based on the Ontario Digital Terrain Model dataset (Ottawa-Gatineau Package G 2019-2020), which represents the bare-earth terrain derived from Light Detection and Ranging (LiDAR) data.

The acoustic model considers a downwind condition as a conservative approach, where the wind direction is always oriented from each source towards each POR. A summary of key acoustic model parameters used in the model is provided in Table 6.1.

Table 6.1 Key Acoustic Model Parameters

Parameter	Value	Rationale
Ground Absorption	0.2	Models acoustically reflective ground conditions (e.g. gravel, hard pack earth) within the Facility development area
	0.8	Models acoustically absorptive ground conditions (e.g. grass and foliated covered ground) between the Facility development area and the modelled PORs
Temperature	10°C	Ontario standard conditions
Relative Humidity	70%	Ontario standard conditions
Max. Order of Reflection	2	Accounts for building reflections

6.2 Modelling Scenarios

O. Reg 1/17 requires the AAR to assess the predictable worst case noise levels from the Facility at the PORs. To consider the predictable worst-case scenario, all non-emergency noise sources are modelled as operating continuously and simultaneously during the day, evening and nighttime. Emergency generator testing is modelled separately from regular operations in accordance with the EASR publication and is assumed to occur during the daytime only. A summary of the modelled operating scenarios is provided in Table 6.2.



Table 6.2 Modelled Operating Scenarios

Modelling Scenario	Period	Modelled Operations (Worst-case 1-hour)
Regular Operations	Daytime (07:00 to 19:00)	The simultaneous and continuous operation of all non-emergency sources.
	Evening (19:00 to 23:00)	
	Nighttime (23:00 to 07:00)	
Emergency Generator Testing	Daytime (07:00 to 19:00)	This assessment assumes the emergency generator will operate for up to 60 minutes during routine testing.
	Evening (19:00 to 23:00)	Not assessed as this study assumes the emergency generator will be tested during the daytime only.
	Nighttime (23:00 to 07:00)	

6.3 Results

6.3.1 Regular Operations

An acoustic assessment summary of the noise impacts at the PORs for regular operations is provided in Table 6.3. Individual noise level contributions from each source at the PORs is provided in Appendix E, Table E.1. Equivalent noise level contours for Regular Operations are provided in Appendix B, Figure 3. Sample acoustic model calculations are provided in Appendix F.



Table 6.3 Acoustic Assessment Summary – Regular Operations

POR ID	POR Description	Period ^a	Predicted Noise Level at POR ^b (L _{eq-1hr} , dBA)	Noise Limit ^c (L _{eq-1hr} , dBA)	Compliance with Noise Limit (Y/N)	Acoustical Classification Area ^d	Verified by Acoustic Audit ^e (Y/N)
POR1	1 Storey Residence - 2807 Stonecrest Road	Daytime	30	45	Y	Class 3	N
		Evening	30	40	Y		
		Nighttime	30	40	Y		
OPOR1	Residence Yard - 2807 Stonecrest Road	Daytime	30	45	Y	Class 3	N
		Evening	30	40	Y		
		Nighttime	N/A	N/A	N/A		
POR2	2 Storey Residence - 2665 Marchurst Road	Daytime	40	45	Y	Class 3	N
		Evening	40	40	Y		
		Nighttime	40	40	Y		
OPOR2	Residence Yard - 2665 Marchurst Road	Daytime	40	45	Y	Class 3	N
		Evening	40	40	Y		
		Nighttime	N/A	N/A	N/A		
POR3	3 Storey Residence - 2655 Marchurst Road	Daytime	40	45	Y	Class 3	N
		Evening	40	40	Y		
		Nighttime	40	40	Y		
OPOR3	Residence Yard - 2655 Marchurst Road	Daytime	39	45	Y	Class 3	N
		Evening	39	40	Y		
		Nighttime	N/A	N/A	N/A		



Acoustic Assessment Report – Evolugen South March Battery Energy Storage Project
6 Impact Assessment
 October 15, 2025

POR ID	POR Description	Period ^a	Predicted Noise Level at POR ^b (L_{eq-1hr}, dBA)	Noise Limit ^c (L_{eq-1hr}, dBA)	Compliance with Noise Limit (Y/N)	Acoustical Classification Area ^d	Verified by Acoustic Audit ^e (Y/N)
POR4	1 Storey Residence - 2620 Marchurst Road	Daytime	37	45	Y	Class 3	N
		Evening	37	40	Y		
		Nighttime	37	40	Y		
OPOR4	Residence Yard - 2620 Marchurst Road	Daytime	37	45	Y	Class 3	N
		Evening	37	40	Y		
		Nighttime	N/A	N/A	N/A		
POR5	2 Storey Residence - 2475 Marchurst Road	Daytime	39	45	Y	Class 3	N
		Evening	39	40	Y		
		Nighttime	39	40	Y		
OPOR5	Residence Yard - 2475 Marchurst Road	Daytime	36	45	Y	Class 3	N
		Evening	36	40	Y		
		Nighttime	N/A	N/A	N/A		
POR6	1 Storey Residence - 110 Edith Margaret Place	Daytime	26	45	Y	Class 3	N
		Evening	26	40	Y		
		Nighttime	26	40	Y		
OPOR6	Residence Yard - 110 Edith Margaret Place	Daytime	26	45	Y	Class 3	N
		Evening	26	40	Y		
		Nighttime	N/A	N/A	N/A		
POR7	2 Storey On-site Residence - 2625 Marchurst Road (Discretionary Receptor)	Daytime	40	45	Y	Class 3	N
		Evening	40	40	Y		
		Nighttime	40	40	Y		



Acoustic Assessment Report – Evolgen South March Battery Energy Storage Project
6 Impact Assessment
 October 15, 2025

POR ID	POR Description	Period ^a	Predicted Noise Level at POR ^b (L _{eq-1hr} , dBA)	Noise Limit ^c (L _{eq-1hr} , dBA)	Compliance with Noise Limit (Y/N)	Acoustical Classification Area ^d	Verified by Acoustic Audit ^e (Y/N)
OPOR7	On-site Residence Yard - 2625 Marchurst Road (Discretionary Receptor)	Daytime	38	45	Y	Class 3	N
		Evening	38	40	Y		
		Nighttime	N/A	N/A	N/A		
POR8	1 Storey Residence - 1620 Thomas A. Dolan Parkway	Daytime	35	45	Y	Class 3	N
		Evening	35	40	Y		
		Nighttime	N/A	N/A	N/A		
OPOR8	Residence Yard - 1620 Thomas A. Dolan Parkway	Daytime	35	45	Y	Class 3	N
		Evening	35	40	Y		
		Nighttime	N/A	N/A	N/A		
VL1	Vacant Lot Receptor - 2655 Marchurst Road	Daytime	39	45	Y	Class 3	N
		Evening	39	40	Y		
		Nighttime	39	40	N/A		

Notes:

- a. Daytime occurs from 07:00 to 19:00. Evening occurs from 19:00 to 23:00. Nighttime occurs from 23:00 to 07:00.
- b. Predicted noise level from sources operating as described in Section 6.2
- c. Applicable noise level limit from Chapter 3 of EASR publication
- d. The classification of the area in which the point of reception is located, per Chapter 3 of the EASR publication.
- e. N - no acoustic audit has been completed, Y - an acoustic audit case been completed and verified compliance



As shown in Table 6.3, the predicted noise levels comply with the applicable noise limits at all modelled receptors. No additional noise control measures are required for the Facility beyond those identified in Section 3 and shown in the site plan (see Appendix A).

6.3.2 Emergency Generator Testing

An acoustic assessment summary of the noise impacts at the PORs for emergency generator testing is provided in Table 6.4. Individual noise level contributions from each source at the PORs is provided in Appendix E, Table E.2. Equivalent noise level contours for emergency generator testing are provided in Appendix B, Figure 4. Sample acoustic model calculations are provided in Appendix F.



Table 6.4 Acoustic Assessment Summary – Emergency Generator Testing

POR ID	POR Description	Period ^a	Noise Level at POR ^b (L _{eq} -1hr, dBA)	Noise Level Limit ^c (L _{eq} -1hr, dBA)	Compliance with Noise Level Limit (Y/N)	Acoustical Classification Area ^d	Verified by Acoustic Audit ^e (Y/N)
POR1	1 Storey Residence - 2807 Stonecrest Road	Daytime	17	50	Y	Class 3	N
		Evening	N/A	N/A	N/A		
		Nighttime	N/A	N/A	N/A		
OPOR1	Residence Yard - 2807 Stonecrest Road	Daytime	18	50	Y	Class 3	N
		Evening	N/A	N/A	N/A		
		Nighttime	N/A	N/A	N/A		
POR2	2 Storey Residence - 2665 Marchurst Road	Daytime	29	50	Y	Class 3	N
		Evening	N/A	N/A	N/A		
		Nighttime	N/A	N/A	N/A		
OPOR2	Residence Yard - 2665 Marchurst Road	Daytime	28	50	Y	Class 3	N
		Evening	N/A	N/A	N/A		
		Nighttime	N/A	N/A	N/A		
POR3	3 Storey Residence - 2655 Marchurst Road	Daytime	29	50	Y	Class 3	N
		Evening	N/A	N/A	N/A		
		Nighttime	N/A	N/A	N/A		
OPOR3	Residence Yard - 2655 Marchurst Road	Daytime	29	50	Y	Class 3	N
		Evening	N/A	N/A	N/A		
		Nighttime	N/A	N/A	N/A		



Acoustic Assessment Report – Evolgen South March Battery Energy Storage Project
6 Impact Assessment
 October 15, 2025

POR ID	POR Description	Period ^a	Noise Level at POR ^b (L_{eq}-1hr, dBA)	Noise Level Limit ^c (L_{eq}-1hr, dBA)	Compliance with Noise Level Limit (Y/N)	Acoustical Classification Area ^d	Verified by Acoustic Audit ^e (Y/N)
POR4	1 Storey Residence - 2620 Marchurst Road	Daytime	30	50	Y	Class 3	N
		Evening	N/A	N/A	N/A		
		Nighttime	N/A	N/A	N/A		
OPOR4	Residence Yard - 2620 Marchurst Road	Daytime	30	50	Y	Class 3	N
		Evening	N/A	N/A	N/A		
		Nighttime	N/A	N/A	N/A		
POR5	2 Storey Residence - 2475 Marchurst Road	Daytime	26	50	Y	Class 3	N
		Evening	N/A	N/A	N/A		
		Nighttime	N/A	N/A	N/A		
OPOR5	Residence Yard - 2475 Marchurst Road	Daytime	26	50	Y	Class 3	N
		Evening	N/A	N/A	N/A		
		Nighttime	N/A	N/A	N/A		
POR6	1 Storey Residence - 110 Edith Margaret Place	Daytime	16	50	Y	Class 3	N
		Evening	N/A	N/A	N/A		
		Nighttime	N/A	N/A	N/A		
OPOR6	Residence Yard - 110 Edith Margaret Place	Daytime	17	50	Y	Class 3	N
		Evening	N/A	N/A	N/A		
		Nighttime	N/A	N/A	N/A		
POR7	2 Storey On-site Residence - 2625 Marchurst Road (Discretionary Receptor)	Daytime	31	50	Y	Class 3	N
		Evening	N/A	N/A	N/A		
		Nighttime	N/A	N/A	N/A		



Acoustic Assessment Report – Evolgen South March Battery Energy Storage Project
6 Impact Assessment
 October 15, 2025

POR ID	POR Description	Period ^a	Noise Level at POR ^b (Leq-1hr, dBA)	Noise Level Limit ^c (Leq-1hr, dBA)	Compliance with Noise Level Limit (Y/N)	Acoustical Classification Area ^d	Verified by Acoustic Audit ^e (Y/N)
OPOR7	On-site Residence Yard - 2625 Marchurst Road (Discretionary Receptor)	Daytime	27	50	Y	Class 3	N
		Evening	N/A	N/A	N/A		
		Nighttime	N/A	N/A	N/A		
POR8	1 Storey Residence - 1620 Thomas A. Dolan Parkway	Daytime	22	50	Y	Class 3	N
		Evening	N/A	N/A	N/A		
		Nighttime	N/A	N/A	N/A		
OPOR8	Residence Yard - 1620 Thomas A. Dolan Parkway	Daytime	23	50	Y	Class 3	N
		Evening	N/A	N/A	N/A		
		Nighttime	N/A	N/A	N/A		
VL1	Accessible Vacant Lot - 2655 Marchurst Road	Daytime	28	50	Y	Class 3	N
		Evening	N/A	N/A	N/A		
		Nighttime	N/A	N/A	N/A		

Notes:

- a. Daytime occurs from 07:00 to 19:00. Evening occurs from 19:00 to 23:00. Nighttime occurs from 23:00 to 07:00.
- b. Predicted noise level from sources operating as described in Section 6.2
- c. Applicable noise level limit from Chapter 3 of EASR publication
- d. The classification of the area in which the point of reception is located per Chapter 3 of the EASR publication.
- e. N - no acoustic audit has been completed, Y - an acoustic audit case been completed and verified compliance.



As shown in Table 6.4, the predicted Facility noise levels meet the applicable noise limits at all modelled PORs during emergency generator testing for the Facility. Therefore, no additional mitigation measures are required for the emergency generator, provided the generator procured for the Facility does not exceed a sound level of 75 dBA at 7 m and is tested during the daytime only. Alternative generators and testing protocols may be acceptable but would need separate evaluation for compliance with the applicable noise limits.



7 Conclusion and Closure

Stantec was retained by Evolgen to prepare an AAR in support of the TF Class EA of the proposed 250 MW South March BESS project in Ottawa, Ontario (the Facility).

This AAR was prepared based on the available Facility information, including the site plan “7154023-100000-41-D20-0001 Rev AH”. Key assumptions noted in this report such as MPT, HVAC, and emergency generator noise emissions should be verified once equipment schedules are finalized and manufacturer sound data is available. If there are changes to the Facility, such as equipment manufacturer /model, sound levels, operating conditions, and layout, this acoustic assessment should be updated to confirm compliance with MECP noise limits and to identify any required noise controls.

For the Facility regular operations, predicted noise levels comply with the applicable MECP limits at the modelled PORs, provided the Facility noise sources, including the main power transformers, do not exceed the sound power levels considered in this report. Further, all BESS units must be equipped with manufacturer-supplied noise reduction kits, and the noise walls/berms must be implemented as shown in the site plan (see Appendix A). The noise walls must be of solid construction without any gaps, have a surface density of 20 kg/m², and conform to the overall heights and extents considered in this assessment. No additional noise control measures are required for the Facility regular operations to demonstrate compliance with MECP noise limits.

For emergency generator testing, noise levels were predicted to meet the applicable MECP noise limits at all PORs under the evaluated testing scenario. As such, no further mitigation measures are expected to be required for the emergency generator.



8 References

City of Ottawa. 2008. "City of Ottawa Zoning By-law 2008-250."

CSA. 2017. "C88-16 Power Transformers and Reactors."

IEEE. 2015. "IEEE Std C57.12.90-2015 Standard Test Code for Liquid-Immersed Distribution, Power and Regulating Transformers."

ISO. 2017. "ISO 1996-2:2017 Description, measurement and assessment of environmental noise-Part 2: Determination of Environmental noise levels."

ISO. 1996. "ISO 9613-2. Acoustics – Attenuation of Sound during propagation outdoors. Part 2 – General method."

MECP. 2021a. "Environmental Activity and Sector Registry – Limits and Other Requirements version 3.0."

MECP. 2021b. "Ontario Regulation 1/17: Registrations Under Part II.2 of The Act – Activities Requiring Assessment of Air Emissions."

MOE. 1978. "Publication NPC-104 - Sound Level Adjustments."



Appendices



Appendix A Facility Drawings



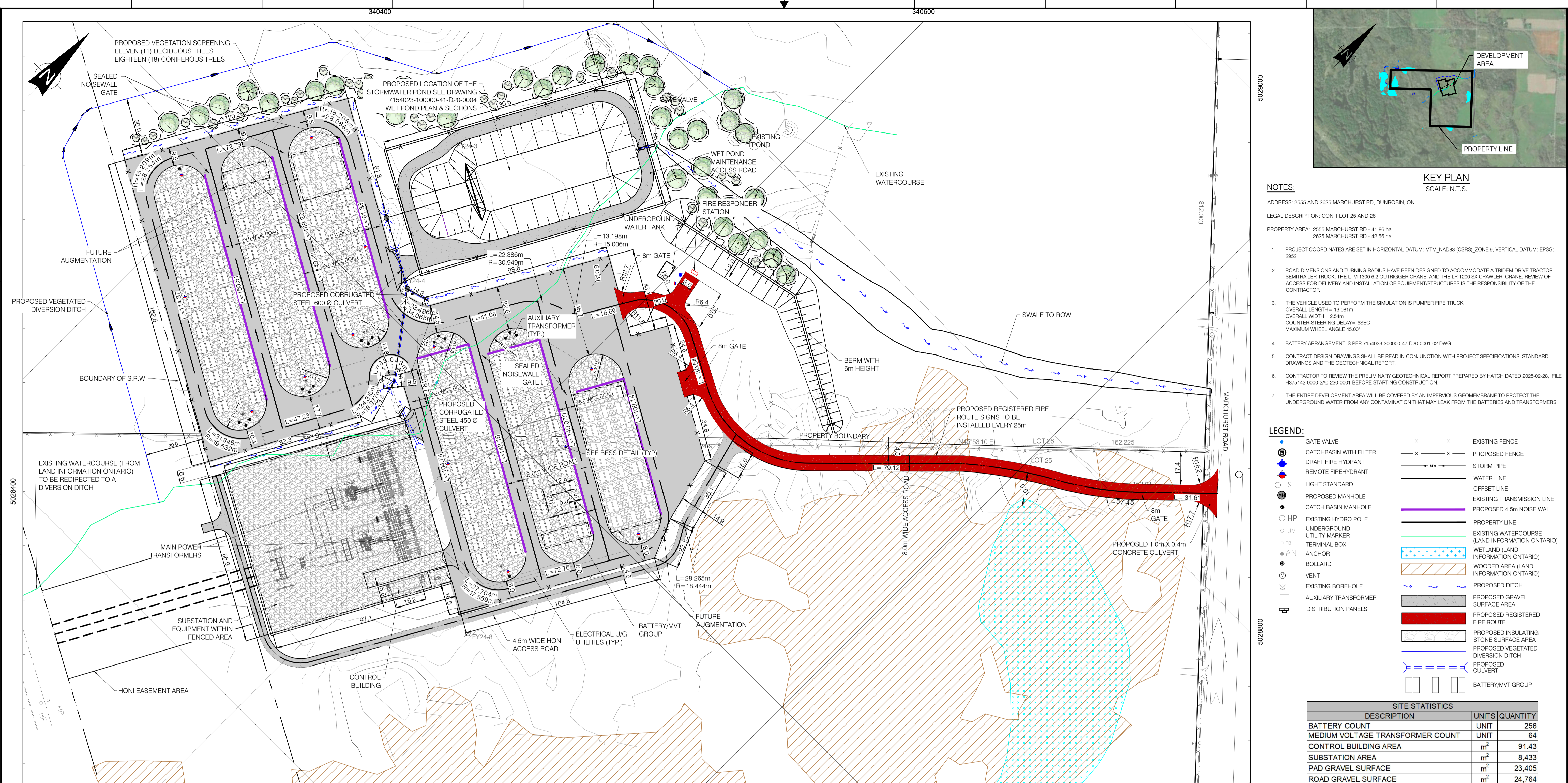

- NOTES:**
- ADDRESS: 2555 AND 2625 MARCHURST RD, DUNROBIN, ON
- LEGAL DESCRIPTION: CON 1 LOT 25 AND 26
2625 MARCHURST RD - 42.56 ha
- PROJECT COORDINATES ARE SET IN HORIZONTAL DATUM: MTM_NAD83 (CSRS)_ZONE 9, VERTICAL DATUM: EFGS_2952
 - ROAD DIMENSIONS AND TURNING RADIUS HAVE BEEN DESIGNED TO ACCOMMODATE A TRIDRIVE TRACTOR SEMITRAILER TRUCK, THE LTM 1300 6.2 OUTRIGGER CRANE AND THE LR 1200 SX CRAWLER CRANE. REVIEW OF ACCESS FOR DELIVERY AND INSTALLATION OF EQUIPMENT/STRUCTURES IS THE RESPONSIBILITY OF THE CONTRACTOR.
 - THE VEHICLE USED TO PERFORM THE SIMULATION IS PUMPER FIRE TRUCK
OVERALL LENGTH= 13.081m
OVERALL WIDTH= 2.54m
COUNTER-STEERING DELAY= 5SEC
MAXIMUM WHEEL ANGLE= 45.00°
 - BATTERY ARRANGEMENT IS PER 7154023-300000-47-D20-0001-02 DWG.
 - CONTRACT DESIGN DRAWINGS SHALL BE READ IN CONJUNCTION WITH PROJECT SPECIFICATIONS, STANDARD DRAWINGS AND THE GEOTECHNICAL REPORT.
 - CONTRACTOR TO REVIEW THE PRELIMINARY GEOTECHNICAL REPORT PREPARED BY HATCH DATED 2025-02-28, FILE H375142-0000-2A0-230-0001 BEFORE STARTING CONSTRUCTION.
 - THE ENTIRE DEVELOPMENT AREA WILL BE COVERED BY AN IMPERVIOUS GEOMEMBRANE TO PROTECT THE UNDERGROUND WATER FROM ANY CONTAMINATION THAT MAY LEAK FROM THE BATTERIES AND TRANSFORMERS.

- LEGEND:**
- GATE VALVE
 - CATCHBASIN WITH FILTER
 - DRAFT FIRE HYDRANT
 - REMOTE FIREHYDRANT
 - LIGHT STANDARD
 - PROPOSED MANHOLE
 - CATCH BASIN MANHOLE
 - EXISTING HYDRO POLE
 - UNDERGROUND UTILITY MARKER
 - TERMINAL BOX
 - ANCHOR
 - BOLLARD
 - VENT
 - EXISTING BOREHOLE
 - AUXILIARY TRANSFORMER
 - DISTRIBUTION PANELS
 - EXISTING FENCE
 - PROPOSED FENCE
 - STORM PIPE
 - WATER LINE
 - OFFSET LINE
 - EXISTING TRANSMISSION LINE
 - PROPOSED 4.5m NOISE WALL
 - PROPERTY LINE
 - EXISTING WATERCOURSE (LAND INFORMATION ONTARIO)
 - WETLAND (LAND INFORMATION ONTARIO)
 - WOODED AREA (LAND INFORMATION ONTARIO)
 - PROPOSED GRAVEL SURFACE AREA
 - PROPOSED REGISTERED FIRE ROUTE
 - PROPOSED INSULATING STONE SURFACE AREA
 - PROPOSED VEGETATED DIVERSION DITCH
 - PROPOSED CULVERT
 - BATTERY/MVT GROUP

SITE STATISTICS		
DESCRIPTION	UNITS	QUANTITY
BATTERY COUNT	UNIT	256
MEDIUM VOLTAGE TRANSFORMER COUNT	UNIT	64
CONTROL BUILDING AREA	m ²	91.43
SUBSTATION AREA	m ²	8,433
PAD GRAVEL SURFACE	m ²	23,405
ROAD GRAVEL SURFACE	m ²	24,764

PLAN VIEW
SCALE 1:1000

ELEVATION NOTES:

- ELEVATIONS SHOWN HEREON ARE GEODETIC, ARE REFERRED TO THE CANADIAN GEODETIC VERTICAL DATUM OF 1928 (CGVD28) AND ARE DERIVED FROM VERTICAL CONTROL MONUMENT 001198BU521 USING REAL TIME KINEMATIC (RTK) GNSS OBSERVATIONS HAVING AN ELEVATION OF 89.209m.

BENCHMARK NOTES:

- SITE BENCHMARKS ARE REBAR ORP C HAVING AN ELEVATION OF 99.38m AND REBAR ORP D HAVING AN ELEVATION OF 94.80m AS SHOWN ON THE FACE OF THE PLAN.

OWNER AND CONSULTANTS		
COMPANIES	PROJECT SCOPE	ADDRESS
EVOLUGEN	PROJECT DEVELOPER	41 RUE VICTORIA, GATINEAU, QC J8X2A1
BBA	CIVIL ENGINEERING	20 CARLSON CTS SUITE 100, ETOBICOKE, ON M9W7K6
STANTEC	PLANNING, LANDSCAPE PLANS	1331 CLYDEAVE #300, OTTAWA, ON K2C3G4
HATCH	GEOTECHNICAL, HYDROGEOLOGY	2800 SPEARMAN DR, MISSISSAUGA, ON L5K2R7
TULLOCH GEOMATICS INC.	SURVEYOR	900 MORRISON DR SUITE 208, OTTAWA ON K2H 8K7

ZONING COMPARISON CHART			
RU-ZONE	REQUIRED	PROVIDED 2555 MARCHURST	PROVIDED 2625 MARCHURST
LOT AREA (MINIMUM)	0.8 ha	41.86 ha	42.56 ha
LOT WIDTH (MINIMUM)	50m	614.7m	312.5m
FRONT YARD (MINIMUM)	50m	253.8m	264.4m
INTERIOR SIDE YARD (MINIMUM)	5m	141.2m	293.5m
REAR YARD (MINIMUM)	10m	161.3m	797.8m
LOT COVERAGE (MAXIMUM)	20%	5%	9%
MINIMUM PARKING SPACES	0.8 PER 100m ² OF GROSS FLOOR AREA	3m	3m
MAX BUILDING HEIGHT	12m	0m	0m

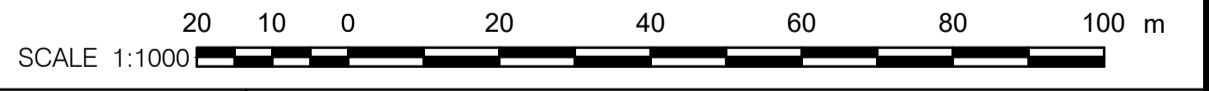

FOR PERMITTING
NOT TO BE USED FOR CONSTRUCTION

DRAWING No.	DESCRIPTION	REV	DESCRIPTION	PREPARED BY	CHECKED BY	DATE
7154023-402000-47-D20-0001	SOUTH MARCH BESS-250 MW 230KV-34.5 KV SUBSTATION	AH	FOR PERMITTING	E. AMELI	M. SHAHRAKI	2025-10-07
		AG	FOR COMMENTS	E. AMELI	M. SHAHRAKI	2025-09-29
		AF	FOR COMMENTS	E. AMELI	M. SHAHRAKI	2025-09-16
		AE	FOR PERMITTING	E. AMELI	M. SHAHRAKI	2025-07-09
		AD	FOR PERMITTING	E. AMELI	M. SHAHRAKI	2025-07-03
		AC	FOR COMMENTS	E. AMELI	M. SHAHRAKI	2025-06-26
		AB	FOR PERMITTING	E. AMELI	M. SHAHRAKI	2025-06-19
		AA	FOR COMMENTS	E. AMELI	M. SHAHRAKI	2025-04-29

Evologen
by Brookfield Renewable

CLIENT:

PROJECT: **SOUTH MARCH**
2555 AND 2625 MARCHURST RD, OTTAWA

TITLE: **SITE PLAN SHEET 2**

PREPARED BY: E. AMELI	DRAFTED BY: D. JAMES
CHECKED BY: E. AMELI	APPROVED BY: M. SHAHRAKI
SCALE: 1:1000	DATE: 2024-04-29

DRAWING No.:	SHEET:	SIZE:	REV.
7154023-100000-41-D20-0001	02	A1	AG

BY: KOKOLAKIS, DANIEL
PRINTED: 2025-10-08 12:15:59 PM

Appendix B Figures



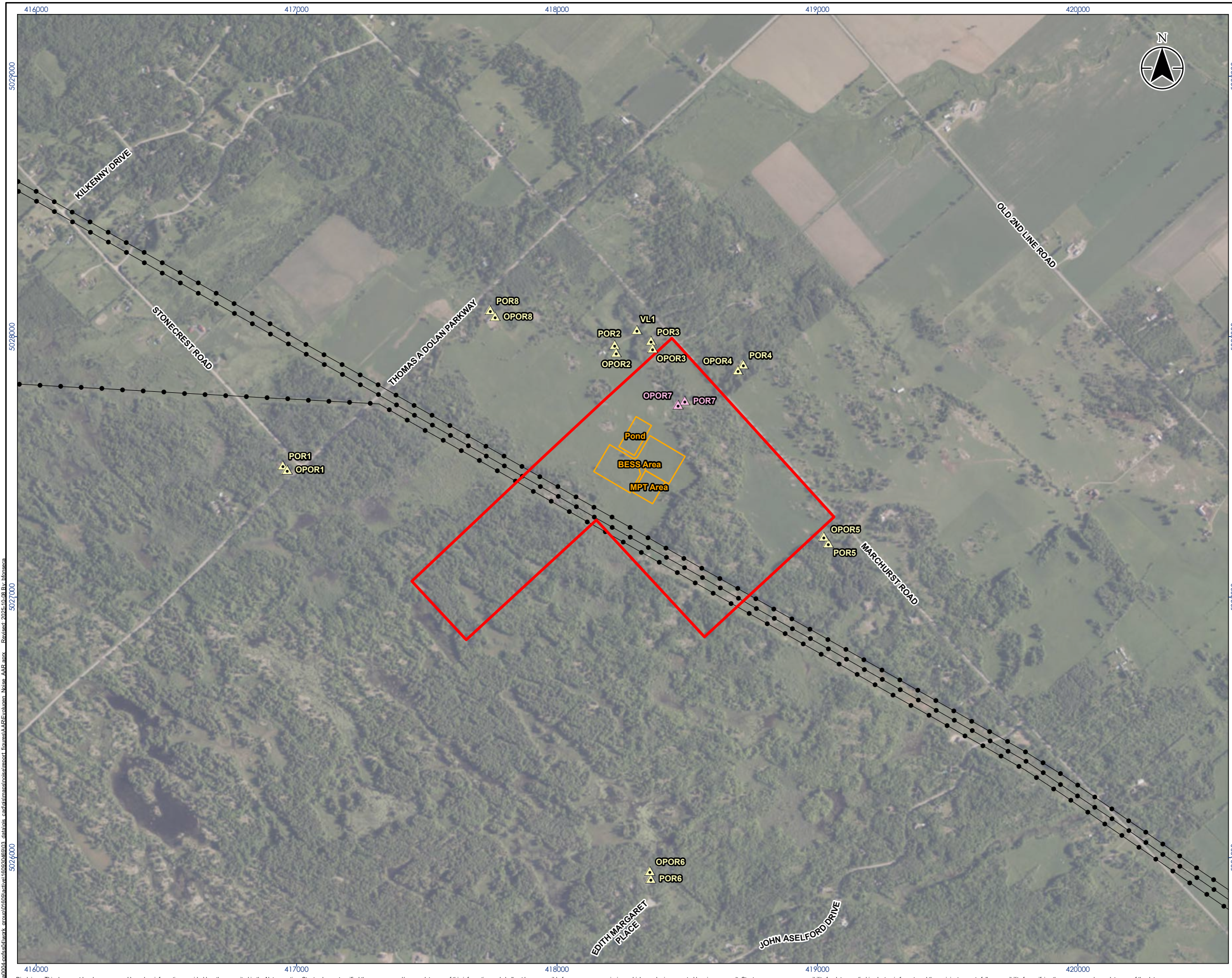

- Legend**
- Discretionary Point of Reception
 - Point of Reception
 - Existing Hydro Line
 - Facility Property Boundary
 - Project Development Area (Approximate)

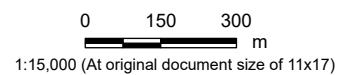

- Notes**
1. Coordinate System: NAD 1983 UTM Zone 18N
 2. Contains information licensed under the Open Government Licence - Ontario, and the Open Government Licence - Canada, accessed 2025.
 3. This figure contains parcel data provided by First Base Solutions®, 2025.
 4. Orthoimagery © City of Ottawa, 2025. Imagery Date, 2022.



Project Location: City of Ottawa
 160930481 REV5
 Prepared by BF on 2025-10-08
 Technical Review by AW on 2025-10-08

Client/Project: Evolgen
 Evolgen South March Battery Storage Project
 Acoustic Assessment Report

Figure No.: **1**
 Title: **Facility Location and Points of Reception**

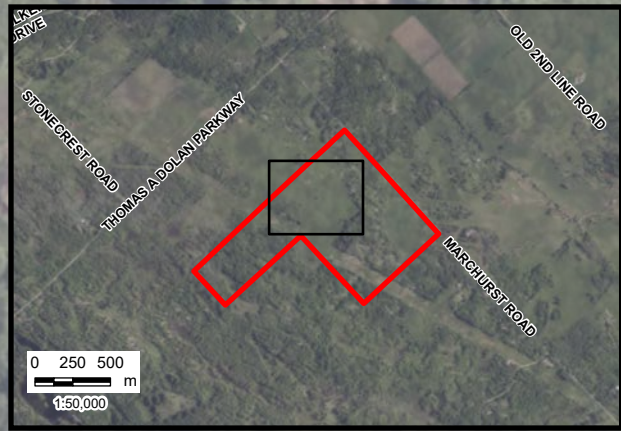

Legend

- Battery Energy Storage System (BESS)
- Emergency Generator
- HVAC Unit
- Main Power Transformers (MPT)
- Medium Voltage Substation
- Earth Berm
- Noise Wall
- Project Development Area (Approximate)
- Facility Property Boundary

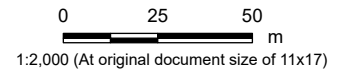

Notes

1. Coordinate System: NAD 1983 UTM Zone 18N
2. Contains information licensed under the Open Government Licence - Ontario, and the Open Government Licence - Canada, accessed 2025.
3. This figure contains parcel data provided by First Base Solutions®, 2025.
4. Orthoimagery © City of Ottawa, 2025. Imagery Date, 2022.



Project Location: City of Ottawa
 Prepared by BF on 2025-10-08
 Technical Review by AW on 2025-10-08
 160930481 REV4

Client/Project: Evolgen
 Evolgen South March Battery Storage Project
 Acoustic Assessment Report

Figure No. **2**

Title: **Modelled Noise Sources, Noise Walls and Earth Berm**

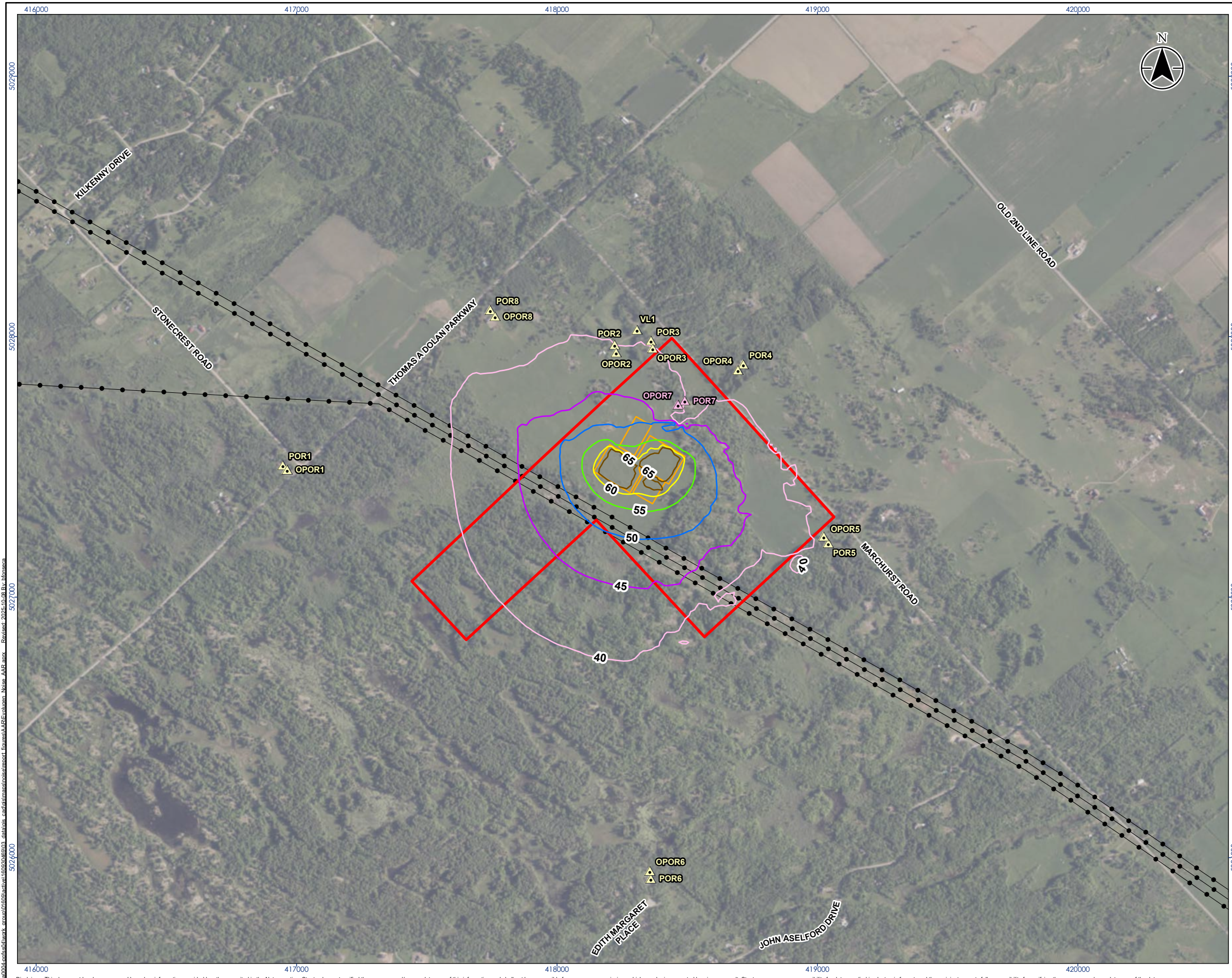

- Legend**
- Discretionary Point of Reception
 - Point of Reception
 - Existing Hydro Line
 - Facility Property Boundary
 - Project Development Area (Approximate)
- Equivalent Noise Level Contours, Leq (dBA)**
- 40
 - 45
 - 50
 - 55
 - 60
 - 65

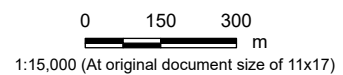

1:15,000 (At original document size of 11x17)

- Notes**
1. Coordinate System: NAD 1983 UTM Zone 18N
 2. Contains information licensed under the Open Government Licence - Ontario, and the Open Government Licence - Canada, accessed 2025.
 3. Equivalent Noise Level Contours are shown at 4.5 m above ground level.
 4. This figure contains parcel data provided by First Base Solutions®, 2025.
 5. Orthoimagery © City of Ottawa, 2025. Imagery Date, 2022.



Project Location: City of Ottawa
 Prepared by BF on 2025-10-08
 Technical Review by AW on 2025-10-08

Client/Project: Evolgen
 Evolgen South March Battery Storage Project
 Acoustic Assessment Report

Figure No. **3**
 Title: **Equivalent Noise Level Contours – Regular Operations**

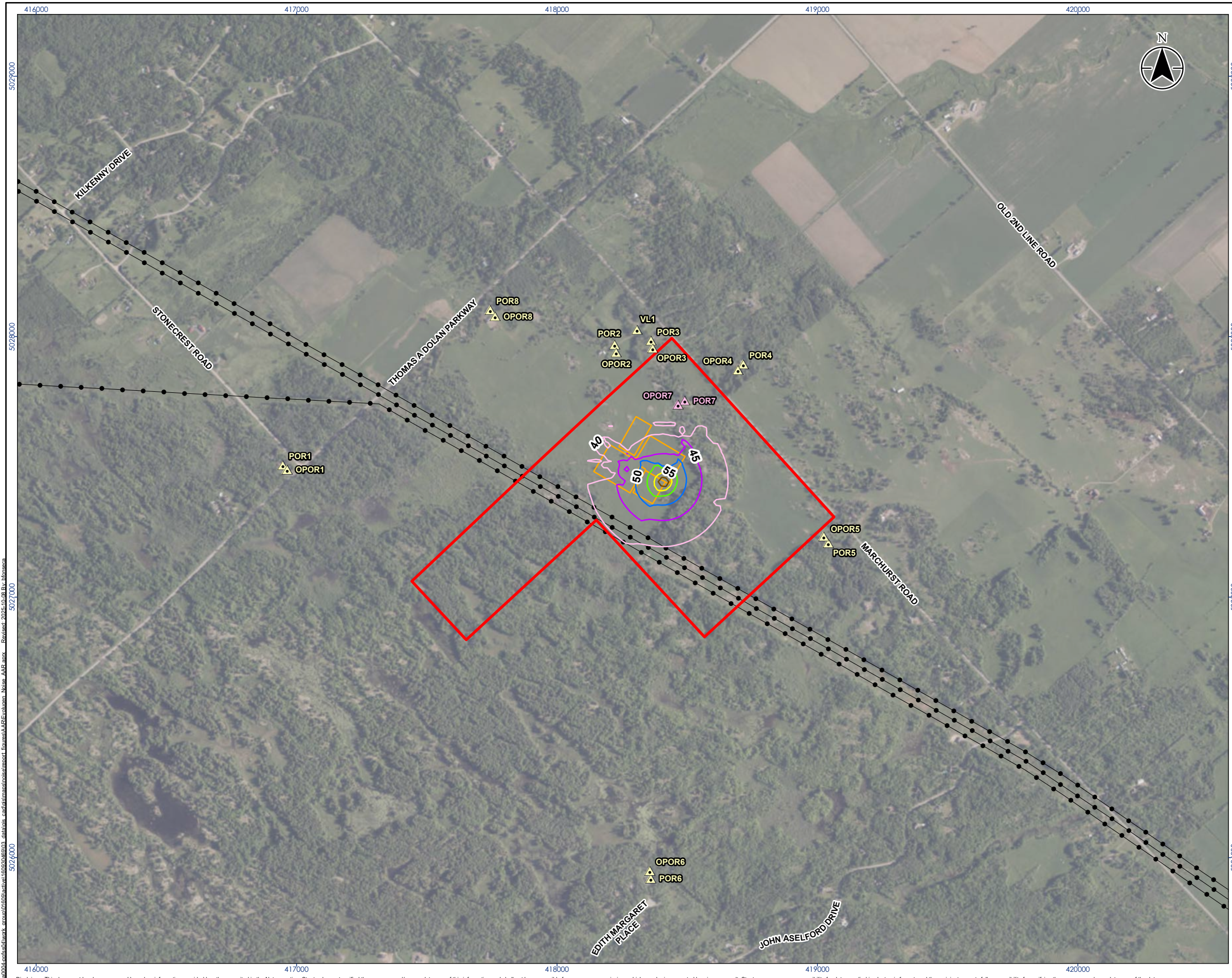

- Legend**
- Discretionary Point of Reception
 - Point of Reception
 - Existing Hydro Line
 - Facility Property Boundary
 - Project Development Area (Approximate)
- Equivalent Noise Level Contours, Leq (dBA)**
- 40
 - 45
 - 50
 - 55
 - 60
 - 65

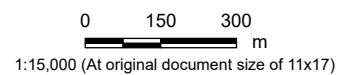

- Notes**
1. Coordinate System: NAD 1983 UTM Zone 18N
 2. Contains information licensed under the Open Government Licence - Ontario, and the Open Government Licence - Canada, accessed 2025.
 3. Equivalent Noise Level Contours are shown at 4.5 m above ground level.
 4. This figure contains parcel data provided by First Base Solutions®, 2025.
 5. Orthoimagery © City of Ottawa, 2025. Imagery Date, 2022.

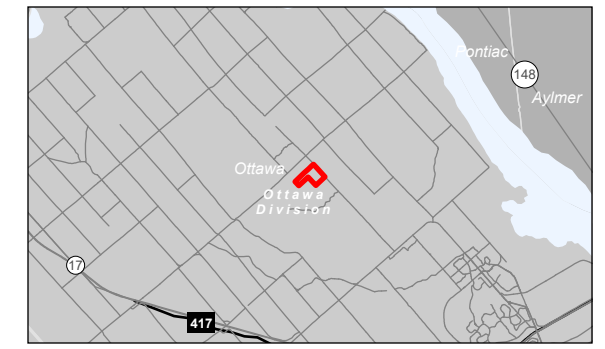

Project Location: City of Ottawa
 160930481 REV3
 Prepared by BF on 2025-10-08
 Technical Review by AW on 2025-10-08

Client/Project: Evolgen
 Evolgen South March Battery Storage Project
 Acoustic Assessment Report

Figure No.: **4**

Title: **Equivalent Noise Level Contours –
 Emergency Generator Testing**

Appendix C Zoning Map



















Source. <https://ottawa.ca/en/planning-development-and-construction/maps-and-zoning#section-e6330c65-a9af-42cc-8ce7-f297656c25>

Legend

Existing Colour Zoning

-  R1 - Residential Zones
-  R2 - Residential Zones
-  R3 - Residential Zones
-  R4 - Residential Zones
-  R5 - Residential Zones
-  GM, LC - Mixed Use Commercial Zones I
-  RM - Mobile Home Park Zone
-  MC, MD, TD - Mixed Use Commercial Zones II
-  AM, TM - Arterial & Traditional Mainstreet Zones
-  IG, T1, T2 - Transportation Zones
-  I1, I2 - Institutional Zones
-  L1, L2, L3, O1 - Open Space and Leisure Zones
-  V1, V2, V3 - Village Residential Zones
-  VM - Village Mixed Use Zone
-  RR - Rural Residential Zone
-  DR - Development Reserve Zone
-  AG - Agricultural Zone

-  RU - Rural Countryside Zone
-  RC - Rural Commercial Zone
-  IH, IL, IP, RG, RH - Industrial Zones
-  RI - Rural Institutional Zone
-  ME - Mineral Extraction Zones
-  MR - Mineral Aggregate Reserve Zone
-  EP - Environmental Zones

Appendix D Manufacturer and Spectral Sound Level Data



Table D.1 Sound Power Level Summary

Source Name	ID	Sound Power Level Octave Band Spectrum (dB)									Overall		Sound Data Reference
		31.5	63	125	250	500	1000	2000	4000	8000	dBA	dB	
Sungrow PowerTitan 2.0 35 deg 80% Power, NR Kit	BESS	84	80	71	70	70	74	65	61	56	79	92	OA,1/1: Manufacturer
Sungrow MVS5140 Medium Voltage Substation	MVS	78	79	81	76	70	67	66	59	50	79	90	OA,1/1: Manufacturer
175 MVA /230kV/ONAF2 Transformer 8m x 6m x 4.6m	MPT	86	92	94	89	89	83	78	73	66	89	98	OA: Evolugen 8-13-25 , IEEE 2015 1/1: Stevens 2010
Rooftop HVAC Unit - 30 Ton, Lennox LCH 360 H	HVAC	-	106	100	94	93	90	84	79	73	95	108	OA,1/1: Manufacturer
Emergency Generator	Gen	-	103	102	101	98	92	90	87	81	100	109	OA: Assumed 75 dBA at 7 m, 1/1 Stantec Database

Noise Test Report

PowerTitan2.0 (4H, HX)



1 Introduction

This document describes noise test result of PowerTitan2.0 (4H, HX).

This document is intended to be used by the specific addressees. No part of this document may be reproduced or distributed in any form or by any means without the prior written permission of SUNGROW Power Supply Co., Ltd.

2 Noise Test

2.1 Test Environment

- (1) Installation conditions: Open ground without reflecting planes.
- (2) Simulated ambient temperature: $-30^{\circ}\text{C} \sim 45^{\circ}\text{C}$ (Rated power)
- (3) Ambient humidity: 52%RH
- (4) Positions of sound level microphones:

Sensor location in sound power level test (test distance $d=1.5\text{m}$, number of measuring points $N=37$)

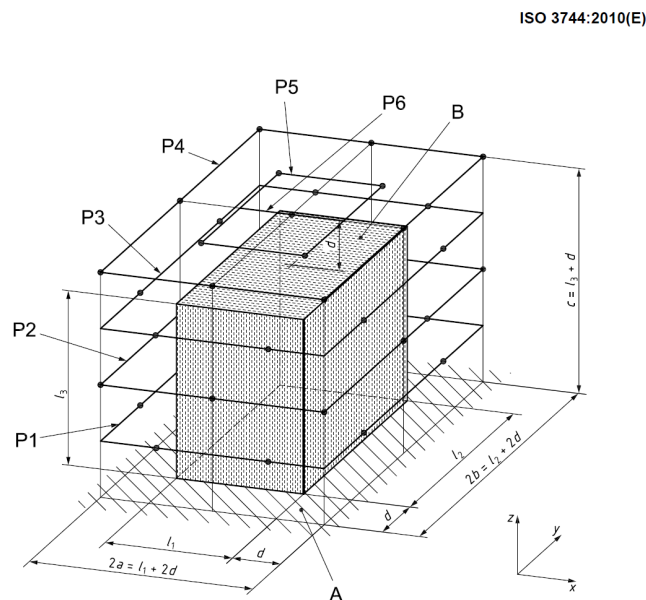

Fig. 1 Positions of Sound Power Level Microphones

Sensor location in sound pressure level test (test distance $d=1\text{m}$, noise on the front, rear, left, right, and top of the product are tested)

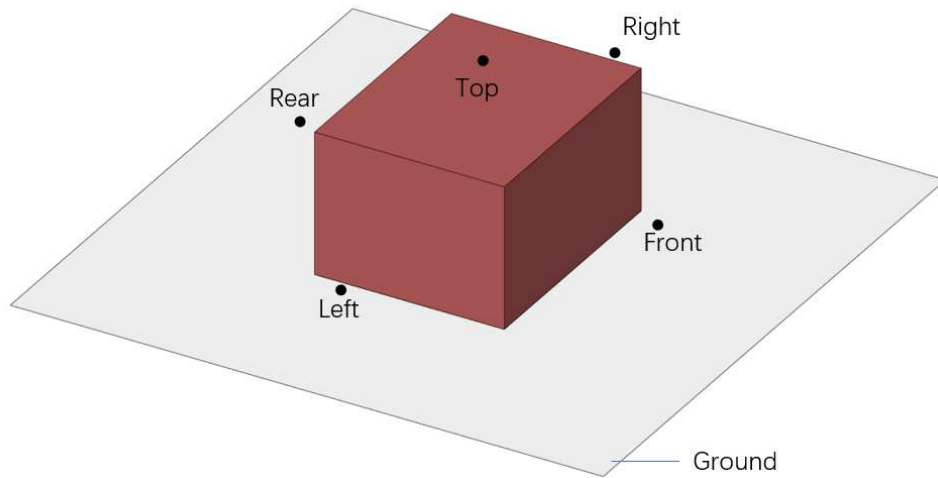

Fig. 2 Positions of Sound Pressure Level Microphones

(5) On-site test environment:



Fig. 3 Test Environment

(6) Background noise: 52.89 dBA

2.2 Test Standards

ISO 3744:2010 *Acoustics - Determination of sound power levels and sound energy*

levels of noise sources using sound pressure - Engineering methods for an essentially free field over a reflecting plane

ISO 11201 Acoustics—Noise emitted by machinery and equipment - Determination of emission sound pressure levels at a work station and at other specified positions in an essentially free field over a reflecting plane with negligible environmental corrections.

2.3 Test Equipment:

Tab. 1 Test Equipment:

Equipment Preparation	Manufacturing Plant	Model	No.	Approved on	Effective Date
Simcenter 12-input Handheld Data Acquisition System	Siemens Industrial Software (Beijing) Co., Ltd.	SCADAS XS	SC-XS12-ACL	2023-09-14	2024-09-13
Acoustic calibrator	PCB	Larson Davis CAL200	21799	2023-10-30	2024-10-29

2.4 Test Condition

Tab. 2 Test Condition

No.	Working Conditions
1	0.25C_45°C Ambient Temperature_100% Power
2	0.25C_45°C Ambient Temperature_80% Power
3	0.25C_45°C Ambient Temperature_50% Power
4	0.25C_35°C Ambient Temperature_100% Power
5	0.25C_35°C Ambient Temperature_80% Power
6	0.25C_35°C Ambient Temperature_50% Power
7	0.25C_30°C Ambient Temperature_100% Power
8	0.25C_30°C Ambient Temperature_80% Power

9	0.25C_30°C Ambient Temperature_50% Power
10	0.25C_≤25°C Ambient Temperature_100% Power
11	0.25C_≤25°C Ambient Temperature_80% Power
12	0.25C_≤25°C Ambient Temperature_50% Power

2.5 Test Result and Conclusion

2.5.1 Sound Power Level Test Result

Tab. 3 Sound Power Level Test Result

Working Conditions	Sound Power Level/dBA	Extended measurement uncertainty U/dB
0.25C_45°C Ambient Temperature_100% Power	84.08	2.9
0.25C_45°C Ambient Temperature_80% Power	84.08	2.9
0.25C_45°C Ambient Temperature_50% Power	78.86	2.9
0.25C_35°C Ambient Temperature_100% Power	79.32	2.9
0.25C_35°C Ambient Temperature_80% Power	79.32	2.9
0.25C_35°C Ambient Temperature_50% Power	77.23	2.9
0.25C_30°C Ambient Temperature_100% Power	79.32	2.9
0.25C_30°C Ambient Temperature_80% Power	79.32	2.9
0.25C_30°C Ambient Temperature_50% Power	77.23	2.9
0.25C_≤25°C Ambient	79.32	2.9

Temperature_100% Power		
0.25C_≤25°C Ambient Temperature_80% Power	79.32	2.9
0.25C_≤25°C Ambient Temperature_50% Power	77.23	2.9

2.5.2 Sound Pressure Level Test Result

Tab. 4 Maximum Sound Pressure Level Test Results of Positions 1m Away from the Surface

Working Conditions	Right/dBA	Rear/dBA	Left/dBA	Front/dBA	Top/dBA
0.25C_45°C Ambient Temperature_100% Power	58.19	59.08	57.97	66.54	72.87
0.25C_45°C Ambient Temperature_80% Power	58.19	59.08	57.97	66.54	72.87
0.25C_45°C Ambient Temperature_50% Power	58.19	55.85	57.11	65.95	64.06
0.25C_35°C Ambient Temperature_100% Power	57.41	56.34	56.52	65.71	65.66
0.25C_35°C Ambient Temperature_80% Power	58.34	56.77	58.16	66.34	65.23
0.25C_35°C Ambient Temperature_50% Power	56.98	54.21	55.69	64.45	57.49
0.25C_30°C Ambient Temperature_100% Power	57.41	56.34	56.52	65.71	65.66
0.25C_30°C Ambient Temperature_80% Power	58.34	56.77	58.16	66.34	65.23
0.25C_30°C Ambient Temperature_50% Power	56.98	54.21	55.69	64.45	57.49
0.25C_≤25°C Ambient Temperature_100% Power	57.41	56.34	56.52	65.71	65.66

0.25C_≤25°C Ambient Temperature_80% Power	58.34	56.77	58.16	66.34	65.23
0.25C_≤25°C Ambient Temperature_50% Power	56.98	54.21	55.69	64.45	57.49

Appendix: Sound Power Level 1/3-Octave Spectrum

Tab. 5 Sound Power Level 1/3-Octave Spectrum (0.25C_45°C_100% Power)

1/3-Octave (Hz)	Sound power level L_{WA} , dBA
25	50.33
31.5	51.52
40	56.46
50	57.59
63	60.40
80	60.48
100	59.55
125	62.82
160	66.06
200	67.00
250	66.31
315	68.80
400	70.19
500	71.60
630	73.60
800	76.22
1000	77.27
1250	73.75
1600	73.11
2000	71.58
2500	69.75

3150	68.09
4000	66.51
5000	64.19
6300	62.43
8000	61.07
10000	58.65
12500	54.86
16000	51.51
20000	47.38

Tab. 6 Sound Power Level 1/3-Octave Spectrum (0.25C_45°C_80% Power)

1/3-Octave (Hz)	Sound power levelL_{WA}, dBA
25	50.33
31.5	51.52
40	56.46
50	57.59
63	60.40
80	60.48
100	59.55
125	62.82
160	66.06
200	67.00
250	66.31
315	68.80
400	70.19
500	71.60
630	73.60
800	76.22
1000	77.27

1250	73.75
1600	73.11
2000	71.58
2500	69.75
3150	68.09
4000	66.51
5000	64.19
6300	62.43
8000	61.07
10000	58.65
12500	54.86
16000	51.51
20000	47.38

Tab. 7 Sound Power Level 1/3-Octave Spectrum (0.25C_45°C_50% Power)

1/3-Octave (Hz)	Sound power level L_{WA}, dBA
25	40.75
31.5	44.25
40	48.95
50	51.40
63	51.31
80	53.07
100	58.76
125	53.91
160	59.62
200	60.56
250	60.38
315	61.38
400	62.46

500	66.07
630	67.51
800	69.68
1000	74.10
1250	68.51
1600	67.83
2000	65.92
2500	64.03
3150	62.42
4000	60.90
5000	58.86
6300	56.91
8000	54.62
10000	51.42
12500	49.12
16000	48.21
20000	45.71

Tab. 8 Sound Power Level 1/3-Octave Spectrum (0.25C_35°C_100% Power)

1/3-Octave (Hz)	Sound power level L_{WA}, dBA
25	40.02
31.5	43.12
40	44.87
50	50.71
63	50.72
80	51.21
100	61.04
125	54.45
160	59.21

200	61.68
250	60.95
315	61.75
400	63.50
500	66.75
630	68.40
800	69.97
1000	74.25
1250	69.05
1600	68.28
2000	66.37
2500	64.70
3150	63.44
4000	61.34
5000	59.75
6300	57.90
8000	55.77
10000	52.51
12500	49.67
16000	48.75
20000	46.11

Tab. 9 Sound Power Level 1/3-Octave Spectrum (0.25C_35°C_80% Power)

1/3-Octave (Hz)	Sound power levelL_{WA}, dBA
25	42.66
31.5	44.56
40	46.73
50	51.95
63	53.44

80	51.78
100	60.22
125	54.71
160	59.17
200	61.15
250	61.21
315	62.01
400	63.60
500	66.61
630	68.15
800	69.98
1000	74.28
1250	68.99
1600	68.17
2000	66.27
2500	64.57
3150	65.02
4000	61.67
5000	59.32
6300	57.42
8000	55.21
10000	52.06
12500	49.46
16000	48.52
20000	45.91

Tab. 10 Sound Power Level 1/3-Octave Spectrum (0.25C_35°C_50% Power)

1/3-Octave (Hz)	Sound power levelL_{WA}, dBA
------------------------	--

25	35.55
31.5	38.12
40	43.13
50	46.97
63	49.46
80	49.45
100	51.79
125	51.78
160	57.58
200	58.49
250	58.14
315	58.39
400	59.23
500	63.13
630	64.64
800	68.19
1000	73.20
1250	66.89
1600	66.20
2000	64.05
2500	61.94
3150	61.46
4000	58.27
5000	56.87
6300	54.38
8000	51.76
10000	49.58
12500	48.14

16000	47.21
20000	45.32

Tab. 11 Sound Power Level 1/3-Octave Spectrum (0.25C_30°C_100% Power)

1/3-Octave (Hz)	Sound power levelL_{WA}, dBA
25	40.02
31.5	43.12
40	44.87
50	50.71
63	50.72
80	51.21
100	61.04
125	54.45
160	59.21
200	61.68
250	60.95
315	61.75
400	63.50
500	66.75
630	68.40
800	69.97
1000	74.25
1250	69.05
1600	68.28
2000	66.37
2500	64.70
3150	63.44
4000	61.34
5000	59.75

6300	57.90
8000	55.77
10000	52.51
12500	49.67
16000	48.75
20000	46.11

Tab. 12 Sound Power Level 1/3-Octave Spectrum (0.25C_30°C_80% Power)

1/3-Octave (Hz)	Sound power level L_{WA}, dBA
25	42.66
31.5	44.56
40	46.73
50	51.95
63	53.44
80	51.78
100	60.22
125	54.71
160	59.17
200	61.15
250	61.21
315	62.01
400	63.60
500	66.61
630	68.15
800	69.98
1000	74.28
1250	68.99
1600	68.17
2000	66.27

2500	64.57
3150	65.02
4000	61.67
5000	59.32
6300	57.42
8000	55.21
10000	52.06
12500	49.46
16000	48.52
20000	45.91

Tab. 13 Sound Power Level 1/3-Octave Spectrum (0.25C_30°C_50% Power)

1/3-Octave (Hz)	Sound power levelL_{WA}, dBA
25	35.55
31.5	38.12
40	43.13
50	46.97
63	49.46
80	49.45
100	51.79
125	51.78
160	57.58
200	58.49
250	58.14
315	58.39
400	59.23
500	63.13
630	64.64
800	68.19

1000	73.20
1250	66.89
1600	66.20
2000	64.05
2500	61.94
3150	61.46
4000	58.27
5000	56.87
6300	54.38
8000	51.76
10000	49.58
12500	48.14
16000	47.21
20000	45.32

Tab. 14 Sound Power Level 1/3-Octave Spectrum (0.25C_≤25°C_100% Power)

1/3-Octave (Hz)	Sound power level L_{WA}, dBA
25	40.02
31.5	43.12
40	44.87
50	50.71
63	50.72
80	51.21
100	61.04
125	54.45
160	59.21
200	61.68
250	60.95
315	61.75

400	63.50
500	66.75
630	68.40
800	69.97
1000	74.25
1250	69.05
1600	68.28
2000	66.37
2500	64.70
3150	63.44
4000	61.34
5000	59.75
6300	57.90
8000	55.77
10000	52.51
12500	49.67
16000	48.75
20000	46.11

Tab. 15 Sound Power Level 1/3-Octave Spectrum (0.25C_≤25°C_80% Power)

1/3-Octave (Hz)	Sound power levelL_{WA}, dBA
25	42.66
31.5	44.56
40	46.73
50	51.95
63	53.44
80	51.78
100	60.22
125	54.71

160	59.17
200	61.15
250	61.21
315	62.01
400	63.60
500	66.61
630	68.15
800	69.98
1000	74.28
1250	68.99
1600	68.17
2000	66.27
2500	64.57
3150	65.02
4000	61.67
5000	59.32
6300	57.42
8000	55.21
10000	52.06
12500	49.46
16000	48.52
20000	45.91

Tab. 16 Sound Power Level 1/3-Octave Spectrum (0.25C_≤25°C_50% Power)

1/3-Octave (Hz)	Sound power levelL_{WA}, dBA
25	35.55
31.5	38.12
40	43.13
50	46.97

63	49.46
80	49.45
100	51.79
125	51.78
160	57.58
200	58.49
250	58.14
315	58.39
400	59.23
500	63.13
630	64.64
800	68.19
1000	73.20
1250	66.89
1600	66.20
2000	64.05
2500	61.94
3150	61.46
4000	58.27
5000	56.87
6300	54.38
8000	51.76
10000	49.58
12500	48.14
16000	47.21
20000	45.32

Appendix: Sound Pressure Level 1/3-Octave Spectrum**Tab. 17 Sound Pressure Level 1/3-Octave Spectrum(0.25C_45°C_100% Power)**

1/3-Octave (Hz)	Right/dBA	Rear/dBA	Left/dBA	Front/dBA	Top/dBA
25	16.28	16.94	15.44	16.85	32.92
31.5	20.61	24.81	20.49	22.26	36.46
40	31.05	29.59	32.19	33.78	37.90
50	35.16	33.55	32.25	34.33	39.58
63	36.45	33.61	34.93	36.80	47.61
80	35.77	33.67	33.52	38.47	46.23
100	35.21	35.25	36.51	39.02	46.22
125	38.19	40.59	42.38	44.06	53.73
160	41.46	41.33	39.25	43.22	53.90
200	40.86	41.66	41.86	46.43	53.07
250	41.14	43.78	41.61	46.82	52.13
315	40.47	44.60	41.75	46.80	56.93
400	41.27	45.86	41.66	46.41	58.88
500	42.49	47.83	43.94	50.09	60.24
630	44.80	47.32	46.03	52.96	63.59
800	49.68	48.76	48.20	57.07	65.11
1000	52.19	50.71	50.66	64.38	63.15
1250	49.27	50.08	49.34	54.14	63.07
1600	48.08	49.86	48.82	51.75	62.98
2000	46.41	48.11	46.59	50.81	60.59
2500	44.67	45.65	44.17	48.54	59.32
3150	42.41	44.02	42.40	46.33	58.61
4000	40.67	41.84	40.43	43.82	57.02
5000	38.95	38.44	38.64	42.91	55.13
6300	36.13	35.93	37.18	39.36	55.20
8000	32.83	35.86	35.04	36.80	54.25
10000	29.17	30.40	30.51	32.69	52.83

12500	26.84	27.70	27.75	29.45	48.38
16000	25.48	27.95	25.47	26.86	43.31
20000	24.96	31.40	23.82	24.05	35.87

Tab. 18 Sound Pressure Level 1/3-Octave Spectrum(0.25C_45°C_80% Power)

1/3-Octave (Hz)	Right/dBA	Rear/dBA	Left/dBA	Front/dBA	Top/dBA
25	16.28	16.94	15.44	16.85	32.92
31.5	20.61	24.81	20.49	22.26	36.46
40	31.05	29.59	32.19	33.78	37.90
50	35.16	33.55	32.25	34.33	39.58
63	36.45	33.61	34.93	36.80	47.61
80	35.77	33.67	33.52	38.47	46.23
100	35.21	35.25	36.51	39.02	46.22
125	38.19	40.59	42.38	44.06	53.73
160	41.46	41.33	39.25	43.22	53.90
200	40.86	41.66	41.86	46.43	53.07
250	41.14	43.78	41.61	46.82	52.13
315	40.47	44.60	41.75	46.80	56.93
400	41.27	45.86	41.66	46.41	58.88
500	42.49	47.83	43.94	50.09	60.24
630	44.80	47.32	46.03	52.96	63.59
800	49.68	48.76	48.20	57.07	65.11
1000	52.19	50.71	50.66	64.38	63.15
1250	49.27	50.08	49.34	54.14	63.07
1600	48.08	49.86	48.82	51.75	62.98
2000	46.41	48.11	46.59	50.81	60.59
2500	44.67	45.65	44.17	48.54	59.32
3150	42.41	44.02	42.40	46.33	58.61
4000	40.67	41.84	40.43	43.82	57.02

5000	38.95	38.44	38.64	42.91	55.13
6300	36.13	35.93	37.18	39.36	55.20
8000	32.83	35.86	35.04	36.80	54.25
10000	29.17	30.40	30.51	32.69	52.83
12500	26.84	27.70	27.75	29.45	48.38
16000	25.48	27.95	25.47	26.86	43.31
20000	24.96	31.40	23.82	24.05	35.87

Tab. 19 Sound Pressure Level 1/3-Octave Spectrum(0.25C_45°C_50% Power)

1/3-Octave (Hz)	Right/dBA	Rear/dBA	Left/dBA	Front/dBA	Top/dBA
25	18.05	18.72	16.14	16.91	34.10
31.5	23.95	25.13	23.02	22.77	34.18
40	29.83	29.50	29.61	30.76	34.05
50	33.16	31.97	32.73	34.20	37.48
63	35.06	32.78	32.42	34.55	36.79
80	34.97	33.32	32.24	37.16	37.37
100	35.77	34.24	35.38	38.07	46.64
125	36.82	33.35	32.96	37.65	39.40
160	40.50	36.62	36.07	39.64	41.78
200	39.51	38.61	39.78	44.14	43.60
250	39.05	38.19	37.55	42.74	43.67
315	39.14	37.10	38.22	43.15	48.82
400	39.27	39.41	39.48	43.16	50.60
500	41.97	41.95	41.45	48.01	52.60
630	43.35	42.87	44.43	50.88	54.23
800	49.35	44.85	45.90	55.63	54.90
1000	51.91	48.95	49.34	64.19	54.79
1250	48.39	47.70	47.80	52.42	54.30
1600	47.31	47.38	47.56	50.26	53.62

2000	46.38	45.44	46.01	49.85	51.33
2500	45.26	42.38	44.77	48.61	50.42
3150	44.69	41.01	44.46	47.34	50.31
4000	45.07	39.18	44.70	47.01	49.90
5000	44.37	36.35	44.15	46.49	49.11
6300	42.14	33.78	42.04	43.41	48.56
8000	38.93	30.92	39.89	40.41	45.60
10000	34.61	28.31	34.87	35.94	41.57
12500	29.60	26.66	29.74	31.40	36.22
16000	25.90	26.22	25.76	26.89	33.57
20000	23.83	24.02	23.34	23.16	25.67

Tab. 20 Sound Pressure Level 1/3-Octave Spectrum(0.25C_35°C_100% Power)

1/3-Octave (Hz)	Right/dBA	Rear/dBA	Left/dBA	Front/dBA	Top/dBA
25	16.49	17.13	15.58	17.51	30.65
31.5	20.22	19.80	19.53	20.68	31.46
40	27.52	25.55	28.39	29.72	34.51
50	31.65	28.64	31.48	32.22	37.64
63	35.23	33.19	32.32	36.33	35.58
80	34.22	32.57	31.45	36.34	35.58
100	36.45	33.28	36.91	38.34	50.96
125	36.04	32.76	32.87	35.88	41.47
160	40.37	36.79	35.45	40.03	43.93
200	42.34	38.66	40.64	42.07	45.48
250	39.40	38.57	37.18	44.12	45.27
315	38.94	38.03	37.38	41.93	48.67
400	40.30	40.80	39.83	43.90	52.72
500	42.96	43.33	42.08	48.21	53.91
630	43.57	43.80	44.65	51.37	56.58

800	49.26	46.66	47.81	55.81	56.90
1000	51.29	50.09	49.60	63.91	56.21
1250	48.52	47.92	47.65	52.75	56.02
1600	47.15	47.34	47.15	50.33	55.11
2000	45.33	45.05	45.20	50.10	52.75
2500	43.50	42.02	42.84	47.87	51.74
3150	41.25	40.41	41.59	45.75	51.30
4000	39.78	38.27	40.25	43.71	50.29
5000	38.69	35.22	38.89	43.41	49.28
6300	35.67	32.64	36.27	39.58	49.41
8000	32.55	30.16	34.01	36.48	47.18
10000	29.23	27.95	30.46	31.59	43.76
12500	26.84	26.60	27.57	28.44	38.37
16000	25.42	26.19	25.38	26.01	35.05
20000	23.84	24.09	23.32	23.09	27.11

Tab. 21 Sound Pressure Level 1/3-Octave Spectrum(0.25C_35°C_80% Power)

1/3-Octave (Hz)	Right/dBA	Rear/dBA	Left/dBA	Front/dBA	Top/dBA
25	17.68	18.28	17.06	16.58	31.18
31.5	20.36	22.66	21.61	20.97	32.28
40	28.50	27.88	29.22	30.15	33.08
50	32.28	29.87	30.78	33.13	35.88
63	34.60	31.49	32.84	34.42	34.96
80	34.69	33.59	33.16	37.49	35.11
100	35.84	34.51	35.78	37.58	48.93
125	37.55	33.47	32.91	37.80	39.72
160	41.39	36.68	36.48	39.98	43.18
200	41.81	39.14	39.94	43.00	44.69
250	39.56	38.86	36.94	43.54	44.52

315	39.97	37.91	38.84	42.65	48.36
400	40.87	40.61	40.42	43.78	52.48
500	42.37	43.63	43.71	48.53	53.73
630	44.91	43.82	45.75	51.25	55.76
800	50.17	46.43	48.04	56.00	56.63
1000	51.91	49.67	49.90	64.63	55.53
1250	48.08	47.92	48.38	52.60	55.59
1600	48.12	48.01	48.35	51.29	54.88
2000	45.94	45.76	47.86	50.81	52.30
2500	46.24	45.04	47.42	48.89	51.63
3150	44.16	42.95	46.67	47.51	51.42
4000	43.64	40.99	44.79	45.91	50.20
5000	42.66	39.17	44.77	45.62	49.61
6300	40.26	35.61	41.01	42.08	49.08
8000	36.67	32.20	38.02	38.81	46.78
10000	32.46	28.68	33.15	34.26	42.95
12500	28.34	26.95	29.04	30.21	37.61
16000	25.62	26.32	25.59	26.53	34.63
20000	23.87	24.07	23.28	23.17	26.50

Tab. 22 Sound Pressure Level 1/3-Octave Spectrum(0.25C_35°C_50% Power)

1/3-Octave (Hz)	Right/dBA	Rear/dBA	Left/dBA	Front/dBA	Top/dBA
25	17.02	15.95	15.41	15.85	17.87
31.5	20.19	21.52	19.45	19.50	21.19
40	29.26	30.06	31.16	30.54	29.14
50	33.14	32.21	32.07	32.35	29.10
63	35.36	31.94	32.45	33.09	32.04
80	34.48	34.14	34.93	36.29	31.27
100	35.24	33.03	34.08	36.57	34.35

125	35.96	32.68	32.35	34.28	33.57
160	39.90	35.83	40.59	38.84	37.56
200	38.05	38.49	40.68	42.37	39.66
250	39.45	37.26	36.45	42.78	39.81
315	39.08	39.01	39.47	41.77	43.63
400	39.22	37.34	39.83	41.62	43.20
500	41.29	38.79	40.89	46.78	44.11
630	42.38	41.04	43.97	50.06	46.21
800	49.08	43.72	45.72	54.79	48.94
1000	51.62	48.44	48.11	62.55	49.34
1250	46.69	45.00	46.22	51.15	48.07
1600	45.27	44.19	45.88	48.79	46.93
2000	45.23	42.53	43.69	49.07	45.47
2500	43.30	40.02	41.80	47.34	44.25
3150	42.33	40.22	42.21	45.22	44.44
4000	40.62	37.71	42.18	44.16	43.05
5000	40.13	34.91	40.38	43.93	41.54
6300	37.54	31.76	37.10	40.50	38.44
8000	33.94	29.16	33.93	37.52	35.37
10000	30.12	27.63	30.54	32.29	31.58
12500	26.59	26.59	27.22	28.42	27.87
16000	24.35	25.66	25.29	25.74	28.95
20000	22.66	24.27	23.36	23.28	23.68

Tab. 23 Sound Pressure Level 1/3-Octave Spectrum(0.25C_30°C_100% Power)

1/3-Octave (Hz)	Right/dBA	Rear/dBA	Left/dBA	Front/dBA	Top/dBA
25	16.49	17.13	15.58	17.51	30.65
31.5	20.22	19.80	19.53	20.68	31.46
40	27.52	25.55	28.39	29.72	34.51

50	31.65	28.64	31.48	32.22	37.64
63	35.23	33.19	32.32	36.33	35.58
80	34.22	32.57	31.45	36.34	35.58
100	36.45	33.28	36.91	38.34	50.96
125	36.04	32.76	32.87	35.88	41.47
160	40.37	36.79	35.45	40.03	43.93
200	42.34	38.66	40.64	42.07	45.48
250	39.40	38.57	37.18	44.12	45.27
315	38.94	38.03	37.38	41.93	48.67
400	40.30	40.80	39.83	43.90	52.72
500	42.96	43.33	42.08	48.21	53.91
630	43.57	43.80	44.65	51.37	56.58
800	49.26	46.66	47.81	55.81	56.90
1000	51.29	50.09	49.60	63.91	56.21
1250	48.52	47.92	47.65	52.75	56.02
1600	47.15	47.34	47.15	50.33	55.11
2000	45.33	45.05	45.20	50.10	52.75
2500	43.50	42.02	42.84	47.87	51.74
3150	41.25	40.41	41.59	45.75	51.30
4000	39.78	38.27	40.25	43.71	50.29
5000	38.69	35.22	38.89	43.41	49.28
6300	35.67	32.64	36.27	39.58	49.41
8000	32.55	30.16	34.01	36.48	47.18
10000	29.23	27.95	30.46	31.59	43.76
12500	26.84	26.60	27.57	28.44	38.37
16000	25.42	26.19	25.38	26.01	35.05
20000	23.84	24.09	23.32	23.09	27.11

Tab. 24 Sound Pressure Level 1/3-Octave Spectrum(0.25C_30°C_80% Power)

1/3-Octave (Hz)	Right/dBA	Rear/dBA	Left/dBA	Front/dBA	Top/dBA
25	17.68	18.28	17.06	16.58	31.18
31.5	20.36	22.66	21.61	20.97	32.28
40	28.50	27.88	29.22	30.15	33.08
50	32.28	29.87	30.78	33.13	35.88
63	34.60	31.49	32.84	34.42	34.96
80	34.69	33.59	33.16	37.49	35.11
100	35.84	34.51	35.78	37.58	48.93
125	37.55	33.47	32.91	37.80	39.72
160	41.39	36.68	36.48	39.98	43.18
200	41.81	39.14	39.94	43.00	44.69
250	39.56	38.86	36.94	43.54	44.52
315	39.97	37.91	38.84	42.65	48.36
400	40.87	40.61	40.42	43.78	52.48
500	42.37	43.63	43.71	48.53	53.73
630	44.91	43.82	45.75	51.25	55.76
800	50.17	46.43	48.04	56.00	56.63
1000	51.91	49.67	49.90	64.63	55.53
1250	48.08	47.92	48.38	52.60	55.59
1600	48.12	48.01	48.35	51.29	54.88
2000	45.94	45.76	47.86	50.81	52.30
2500	46.24	45.04	47.42	48.89	51.63
3150	44.16	42.95	46.67	47.51	51.42
4000	43.64	40.99	44.79	45.91	50.20
5000	42.66	39.17	44.77	45.62	49.61
6300	40.26	35.61	41.01	42.08	49.08
8000	36.67	32.20	38.02	38.81	46.78
10000	32.46	28.68	33.15	34.26	42.95

12500	28.34	26.95	29.04	30.21	37.61
16000	25.62	26.32	25.59	26.53	34.63
20000	23.87	24.07	23.28	23.17	26.50

Tab. 25 Sound Pressure Level 1/3-Octave Spectrum(0.25C_30°C_50% Power)

1/3-Octave (Hz)	Right/dBA	Rear/dBA	Left/dBA	Front/dBA	Top/dBA
25	17.02	15.95	15.41	15.85	17.87
31.5	20.19	21.52	19.45	19.50	21.19
40	29.26	30.06	31.16	30.54	29.14
50	33.14	32.21	32.07	32.35	29.10
63	35.36	31.94	32.45	33.09	32.04
80	34.48	34.14	34.93	36.29	31.27
100	35.24	33.03	34.08	36.57	34.35
125	35.96	32.68	32.35	34.28	33.57
160	39.90	35.83	40.59	38.84	37.56
200	38.05	38.49	40.68	42.37	39.66
250	39.45	37.26	36.45	42.78	39.81
315	39.08	39.01	39.47	41.77	43.63
400	39.22	37.34	39.83	41.62	43.20
500	41.29	38.79	40.89	46.78	44.11
630	42.38	41.04	43.97	50.06	46.21
800	49.08	43.72	45.72	54.79	48.94
1000	51.62	48.44	48.11	62.55	49.34
1250	46.69	45.00	46.22	51.15	48.07
1600	45.27	44.19	45.88	48.79	46.93
2000	45.23	42.53	43.69	49.07	45.47
2500	43.30	40.02	41.80	47.34	44.25
3150	42.33	40.22	42.21	45.22	44.44
4000	40.62	37.71	42.18	44.16	43.05

5000	40.13	34.91	40.38	43.93	41.54
6300	37.54	31.76	37.10	40.50	38.44
8000	33.94	29.16	33.93	37.52	35.37
10000	30.12	27.63	30.54	32.29	31.58
12500	26.59	26.59	27.22	28.42	27.87
16000	24.35	25.66	25.29	25.74	28.95
20000	22.66	24.27	23.36	23.28	23.68

Tab. 26 Sound Pressure Level 1/3-Octave Spectrum(0.25C_≤25°C_100% Power)

1/3-Octave (Hz)	Right/dBA	Rear/dBA	Left/dBA	Front/dBA	Top/dBA
25	16.49	17.13	15.58	17.51	30.65
31.5	20.22	19.80	19.53	20.68	31.46
40	27.52	25.55	28.39	29.72	34.51
50	31.65	28.64	31.48	32.22	37.64
63	35.23	33.19	32.32	36.33	35.58
80	34.22	32.57	31.45	36.34	35.58
100	36.45	33.28	36.91	38.34	50.96
125	36.04	32.76	32.87	35.88	41.47
160	40.37	36.79	35.45	40.03	43.93
200	42.34	38.66	40.64	42.07	45.48
250	39.40	38.57	37.18	44.12	45.27
315	38.94	38.03	37.38	41.93	48.67
400	40.30	40.80	39.83	43.90	52.72
500	42.96	43.33	42.08	48.21	53.91
630	43.57	43.80	44.65	51.37	56.58
800	49.26	46.66	47.81	55.81	56.90
1000	51.29	50.09	49.60	63.91	56.21
1250	48.52	47.92	47.65	52.75	56.02
1600	47.15	47.34	47.15	50.33	55.11

2000	45.33	45.05	45.20	50.10	52.75
2500	43.50	42.02	42.84	47.87	51.74
3150	41.25	40.41	41.59	45.75	51.30
4000	39.78	38.27	40.25	43.71	50.29
5000	38.69	35.22	38.89	43.41	49.28
6300	35.67	32.64	36.27	39.58	49.41
8000	32.55	30.16	34.01	36.48	47.18
10000	29.23	27.95	30.46	31.59	43.76
12500	26.84	26.60	27.57	28.44	38.37
16000	25.42	26.19	25.38	26.01	35.05
20000	23.84	24.09	23.32	23.09	27.11

Tab. 27 Sound Pressure Level 1/3-Octave Spectrum(0.25C_≤25°C_80% Power)

1/3-Octave (Hz)	Right/dBA	Rear/dBA	Left/dBA	Front/dBA	Top/dBA
25	17.68	18.28	17.06	16.58	31.18
31.5	20.36	22.66	21.61	20.97	32.28
40	28.50	27.88	29.22	30.15	33.08
50	32.28	29.87	30.78	33.13	35.88
63	34.60	31.49	32.84	34.42	34.96
80	34.69	33.59	33.16	37.49	35.11
100	35.84	34.51	35.78	37.58	48.93
125	37.55	33.47	32.91	37.80	39.72
160	41.39	36.68	36.48	39.98	43.18
200	41.81	39.14	39.94	43.00	44.69
250	39.56	38.86	36.94	43.54	44.52
315	39.97	37.91	38.84	42.65	48.36
400	40.87	40.61	40.42	43.78	52.48
500	42.37	43.63	43.71	48.53	53.73
630	44.91	43.82	45.75	51.25	55.76

800	50.17	46.43	48.04	56.00	56.63
1000	51.91	49.67	49.90	64.63	55.53
1250	48.08	47.92	48.38	52.60	55.59
1600	48.12	48.01	48.35	51.29	54.88
2000	45.94	45.76	47.86	50.81	52.30
2500	46.24	45.04	47.42	48.89	51.63
3150	44.16	42.95	46.67	47.51	51.42
4000	43.64	40.99	44.79	45.91	50.20
5000	42.66	39.17	44.77	45.62	49.61
6300	40.26	35.61	41.01	42.08	49.08
8000	36.67	32.20	38.02	38.81	46.78
10000	32.46	28.68	33.15	34.26	42.95
12500	28.34	26.95	29.04	30.21	37.61
16000	25.62	26.32	25.59	26.53	34.63
20000	23.87	24.07	23.28	23.17	26.50

Tab. 28 Sound Pressure Level 1/3-Octave Spectrum(0.25C_≤25°C_50% Power)

1/3-Octave (Hz)	Right/dBA	Rear/dBA	Left/dBA	Front/dBA	Top/dBA
25	17.02	15.95	15.41	15.85	17.87
31.5	20.19	21.52	19.45	19.50	21.19
40	29.26	30.06	31.16	30.54	29.14
50	33.14	32.21	32.07	32.35	29.10
63	35.36	31.94	32.45	33.09	32.04
80	34.48	34.14	34.93	36.29	31.27
100	35.24	33.03	34.08	36.57	34.35
125	35.96	32.68	32.35	34.28	33.57
160	39.90	35.83	40.59	38.84	37.56
200	38.05	38.49	40.68	42.37	39.66
250	39.45	37.26	36.45	42.78	39.81

315	39.08	39.01	39.47	41.77	43.63
400	39.22	37.34	39.83	41.62	43.20
500	41.29	38.79	40.89	46.78	44.11
630	42.38	41.04	43.97	50.06	46.21
800	49.08	43.72	45.72	54.79	48.94
1000	51.62	48.44	48.11	62.55	49.34
1250	46.69	45.00	46.22	51.15	48.07
1600	45.27	44.19	45.88	48.79	46.93
2000	45.23	42.53	43.69	49.07	45.47
2500	43.30	40.02	41.80	47.34	44.25
3150	42.33	40.22	42.21	45.22	44.44
4000	40.62	37.71	42.18	44.16	43.05
5000	40.13	34.91	40.38	43.93	41.54
6300	37.54	31.76	37.10	40.50	38.44
8000	33.94	29.16	33.93	37.52	35.37
10000	30.12	27.63	30.54	32.29	31.58
12500	26.59	26.59	27.22	28.42	27.87
16000	24.35	25.66	25.29	25.74	28.95
20000	22.66	24.27	23.36	23.28	23.68

Note: In the above noise test, the supplier of the liquid cooling unit is Sanhe Tongfei, and the supplier of the air cooler fan is EBM. If there is a change in the supplier, there may be deviations in the test data.

Noise Instructions

MVS5140-LS&MVS5140-LS-US 

(with Noise-Relief Cover)



1 Introduction

This document introduces the noise test results of MVS5140-LS and MVS5140-LS-US.

This document is intended to be used by the specific addressees. No part of this document may be reproduced or distributed in any form or by any means without the prior written permission of Sungrow Power Supply Co., Ltd.

2 General Information

2.1 Product Information

The MVS5140-LS-US consists of an MV transformer, an SCC (with LV busbar), and a container. The physical image is as follows:



Fig. 1 MVS5140-LS-US Physical Image

The MVS5140-LS consists of an MV transformer, an SCC (with LV busbar), a ring main unit (RMU), and a container. The physical image is as follows:



Fig. 2 MVS5140-LS Physical Image

Based on the product design, the differences between the MVS5140-LS and the MVS5140-LS-US are as follows:

(2) The SCC is the primary noise source for both the MVS5140-LS and the MVS5140-LS-US. The SCC for the two models has the same structural design and fan selection, resulting in identical noise levels.

(1) The MVS5140-LS uses a preassembled substation with a noise level of $L_{wA}=63.8$ dBA, while the MVS5140-LS-US utilizes a combined transformer with a noise level of $L_{wA}=58.64$ dBA. The difference in noise levels has minimal impact on the overall noise level of the system.

Conclusion: The overall noise level of the MVS5140-LS is higher than that of the MVS5140-LS-US, thus the test results for the MVS5140-LS can be applied to the MVS5140-LS-US.

3 Noise Test

3.1 Test Environment

- Test environment: Open and flat reflective ground surface

- Ambient temperature: 20 °C (atmospheric ambient temperature has no effect on test results)

- Ambient humidity: 50%RH

(1) The positions of sound power level sensors are as follows (test distance $d=1.5\text{m}$, number of measuring points $N=37$), with reference to ISO3744-Annex C, Figure C.10.

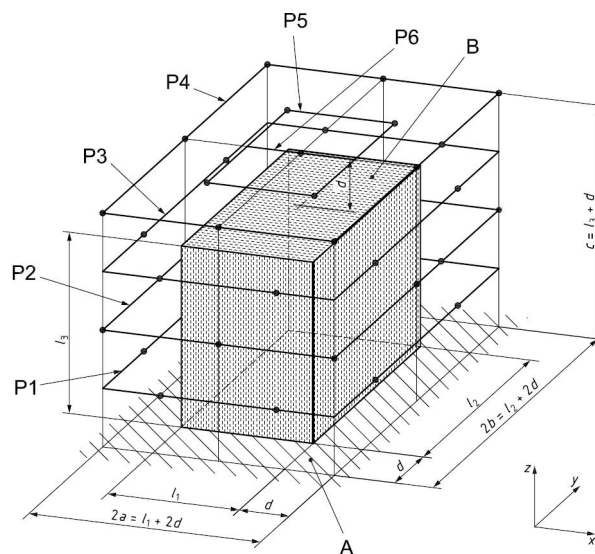

Fig. 3 Positions of Sound Power Level Sensors

(2) Positions of sound pressure level sensors (test distance $d=1\text{m}$, noise on the front, back, left, right, and top of the product are tested).

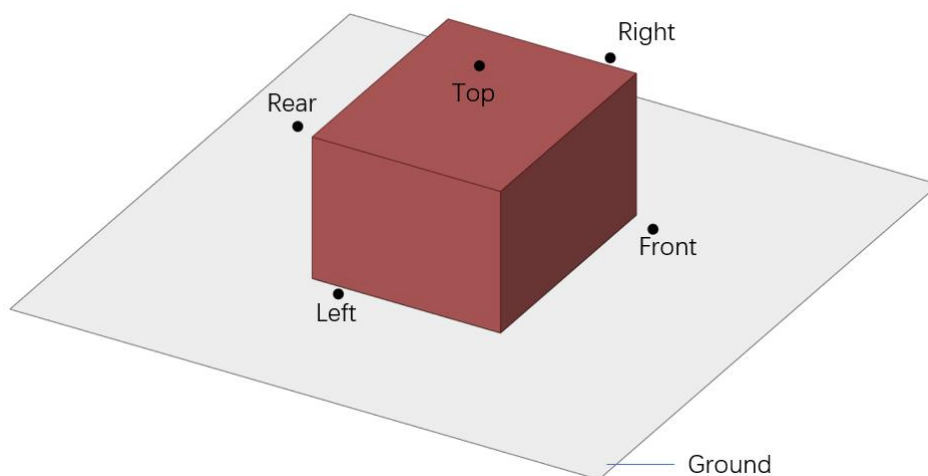

Fig. 4 Positions of Sound Pressure Level Sensors

(3) The on-site test is shown as follows:



Fig. 5 On-Site Test

(4) Background noise level: 57.3 dBA

3.2 Test Basis

ISO 3744:2010 *Acoustics—Determination of sound power levels and sound energy levels of noise sources using sound pressure—Engineering methods for an essentially free field over a reflecting plane.*

ISO 11201:2010 *Acoustics—Noise emitted by machinery and equipment - Determination of emission sound pressure levels at a work station and at other specified positions in an essentially free field over a reflecting plane with negligible environmental corrections.*

ISO 11202:2010 *Acoustics—Noise emitted by machinery and equipment—Determination of emission sound pressure levels at a work station and at other specified positions applying approximate environmental corrections.*

3.3 Test Equipment:

Tab. 1 Test Equipment

Equipment Preparation	Manufacturing Plant	Model	Approved on	Effective Date
Simcenter 12-input Handheld Data Acquisition System	Siemens	SC-XS12-AC	2024-07-11	2025-07-10
Sound Calibrator	B&K	4231	2024-03-20	2025-03-19
Microphone	PCB	378B02	2024-06-18	2025-06-17

Note: The data acquisition system meets the requirements of IEC61260:1995, Class 1, the microphone meets the requirements of IEC61672-1:2002, Class 1, and the sound calibrator meets the requirements of IEC60942:2003, Class 1.

3.4 Test Result

3.4.1 Sound Power Level Test Results

Tab. 2 Sound Power Level Test Results

Working Conditions	Sound Power Level L_{WA} /dBA	Expanded Uncertainty U/dB
Running at full power	79.3	2.4

Note: The sound power level of the MV transformer is 63.8 dBA, which has a negligible impact on the overall sound power level test results and can be disregarded.

3.4.2 Max. Sound Pressure Level of Each Surface (dBA) @ 1m

Tab. 3 Max. Sound Pressure Level of Each Surface (dBA) @ 1m

Working Conditions	Front	Right	Back	Left	Top	Expanded Uncertainty U/dB
Running at full power	54.8	50.6*	66.1	59.3	57.5	2.4

Note: "*" indicates that the background noise does not meet the standard ISO11201 but satisfies ISO11202. The value represents the upper limit of the sound pressure level under this condition (The difference between the average sound pressure level of the overall product and the background noise sound pressure level is less than 3 dBA. According to ISO11202, the correction value is set to -3 dBA).

3.4.3 Supplementary Information

Tab. 4 Sound Power Levels Under 1/3 Octave

1/3 Octave (Hz)	Sound power level L_{WA} , dBA	1/3 Octave (Hz)	Sound power level L_{WA} , dBA	1/3 Octave (Hz)	Sound power level L_{WA} , dBA
25	33.3	250	67.4	2500	65.7
31.5	38.7	315	68.2	3150	62.7
40	43.2	400	70.3	4000	60.0
50	52.1	500	67.0	5000	57.4
63	52.7	630	67.4	6300	51.8
80	56.3	800	67.7	8000	48.5
100	60.0	1000	67.4	10000	43.6
125	64.7	1250	67.9	12500	39.2
160	67.8	1600	67.6	16000	34.6
200	67.5	2000	66.8	20000	28.2

Note: The bolded frequency values represent the center frequency of the octave.

Tab. 5 Sound Pressure Rate Levels Under 1/3 Octave

	Front	Right	Back	Left	Top
1/3 Octave (Hz)	Sound Pressure Level L_{PA}, dBA				
25	12.3	9.5	14.2	11.5	10.2
31.5	17.9	15.0	21.9	19.5	17.3
40	20.4	20.0	26.1	23.0	19.9
50	25.5	27.0	36.0	30.2	27.4
63	30.0	31.1	35.6	34.6	27.2
80	32.6	33.2	41.1	38.4	31.5
100	33.1	31.7	46.4	36.9	36.5
125	39.0	36.6	50.9	41.3	40.6
160	43.0	38.1	54.1	43.9	46.1
200	43.5	38.0	53.9	46.2	47.7

250	44.0	37.2	52.7	44.7	47.4
315	44.0	38.3	54.0	48.1	46.8
400	44.3	40.4	58.9	50.1	46.9
500	45.6	38.9	52.3	50.7	45.1
630	43.6	39.4	52.0	51.0	46.3
800	44.2	40.3	53.8	48.1	46.5
1000	43.1	39.4	54.2	47.2	45.7
1250	42.9	39.8	56.0	46.9	46.2
1600	41.8	39.3	54.7	46.9	44.7
2000	40.3	38.1	53.1	45.2	45.2
2500	38.9	36.2	53.3	44.6	43.2
3150	36.0	34.3	50.5	42.0	39.7
4000	32.7	31.3	48.5	39.1	35.8
5000	28.7	27.4	45.7	36.1	31.9
6300	24.0	21.4	40.5	30.6	26.7
8000	18.4	15.6	40.7	27.4	22.4
10000	12.8	8.1	35.1	23.1	18.1
12500	8.0	3.4	31.1	18.7	12.9
16000	4.1	1.2	27.7	12.8	8.6
20000	0.1	-1.5	20.2	5.5	1.6

Note: The bolded frequency values represent the center frequency of the octave.

4 Conclusion

Based on the above description and noise test data, it can be concluded that both MVS5140-LS and MVS5140-LS-US meet the requirement, with the maximum sound pressure level noise <67dBA@1m.

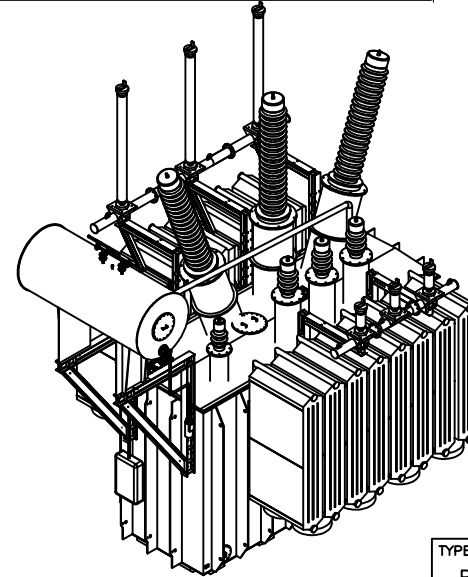
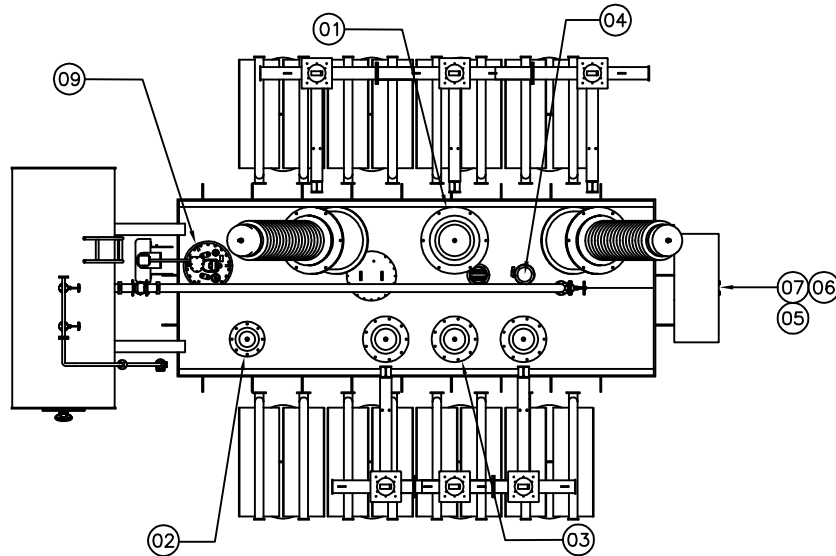
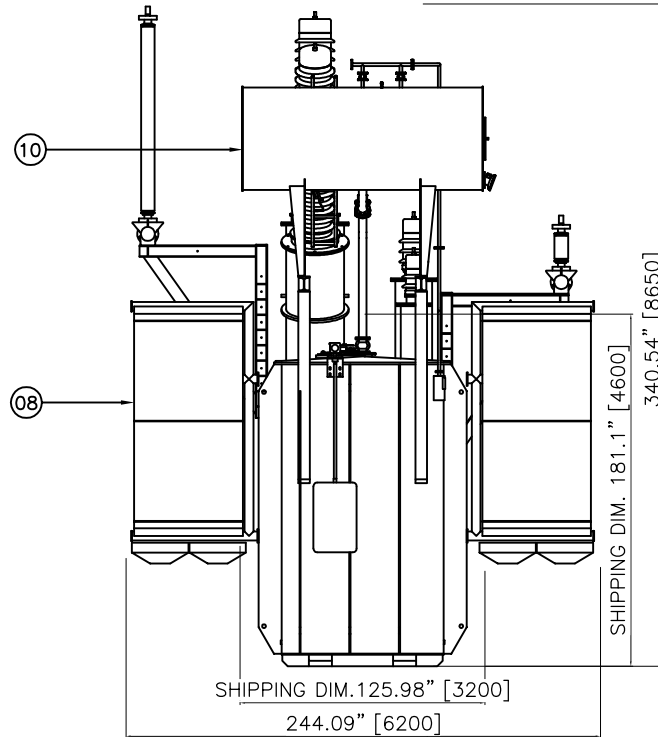
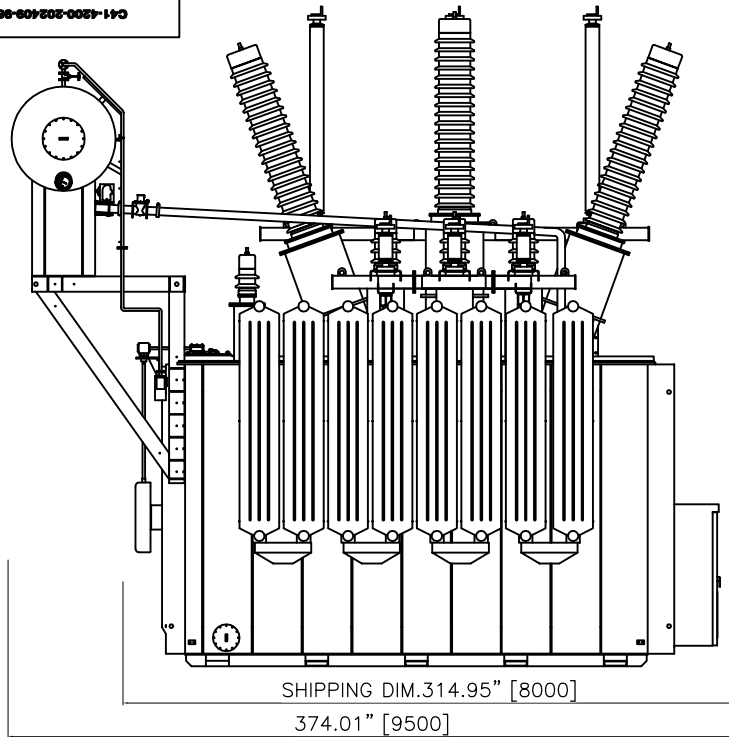

NO.	DESCRIPTION
01	H.V BUSHING
02	HO BUSHING
03	X.V BUSHING
04	PRESSURE RELIEF DEVICE
05	WINDING TEMPERATURE INDICATOR
06	LOCAL CONTROL PANEL
07	OIL TEMPERATURE INDICATOR
08	RADIATOR
09	OLTC
10	MAIN CONSERVATOR

WEIGHTS	
CORE & COIL	198,400 lbs 90,000 kg
TANK & FITTING	82,300 lbs 37,300 kg
INSULATING OIL	89,700 lbs 40,700 kg
TOTAL WEIGHT	370,400 lbs 168,000 kg

TRANSPORTATION	
DIMENSIONS	315.0 (LG)x 8.000 (LG)x 126.0 (WD)x 3.200 (WD)x 181.1 (HT) 4.600 (HT)
WEIGHT (WITHOUT OIL)	252,000 lbs 114,300 kg

NOTE : 1. ALL DIMENSIONS ARE IN MILLIMETERS.
2. DIMENSION TOLERANCE : ±5%
3. WEIGHT TOLERANCE : ±5%
4. THIS DRAWING IS FOR BIDDING ONLY.
5. DIMENSION AND WEIGHT WILL BE CHANGED SLIGHTLY AFTER DETAIL DESIGN.

3ph 60Hz 105/140/175MVA 230/34.5kV YD ONAN/ONAF/ONAF w/OLTC on HV

CHANGE

TYPE POWER TRANSFORMER				DWG. NAME OUTLINE			
DRAWN	CHECKED	CHECKED	APPROVED	FIRST ANGLE PROJECTION	SCALE	N	DATE 2025.01.15
				REF. DWG. NO.			REV. NO.
HYOSUNG 南通晓星				DWG. NO.	C41-4200-202409-0042-1000		

ROOFTOP UNITS

20 TO 30 TONS

¹ Test Conditions		External Static Pressure in. w.c.	CFM	Octave Band Sound Power Levels dBA, re 10 ⁻¹² Watts								¹ Sound Rating Number (dBA)	
				Center Frequency - Hz									
				² 63	125	250	500	1000	2000	4000	8000		
LCH/LGH													
Outdoor Sound Levels	242H, 300H, 360H	---	---	80	84	85	90	90	85	80	72	95	
242H/300H													
Indoor Sound Levels	S.A. Only	790 rpm	1.15	8750	57	67	66	73	72	73	70	63	---
		900 rpm	1.50	10,000	59	71	71	76	76	76	73	67	---
	R.A. Only	790 rpm	1.15	8750	55	63	58	60	59	60	58	52	---
		900 rpm	1.50	10,000	57	67	61	63	63	63	62	56	---
360H													
Indoor Sound Levels	S.A. Only	860 rpm	1.15	10,500	59	71	71	76	76	77	73	66	---
		985 rpm	1.50	12,000	61	74	75	79	80	80	77	70	---
	R.A. Only	860 rpm	1.15	10,500	56	67	61	63	62	63	61	55	---
		985 rpm	1.50	12,000	59	70	65	66	67	67	66	59	---

Note – The octave sound power data does not include tonal corrections.

¹ Indoor tested according to AHRI Standard 370.

² 63Hz band is not certified and is usually lower than reported.

Appendix E Impact Assessment Tables



Table E.1 Noise Impact Summary - Regular Operations

Source ID	Source Description	POR1		OPOR1		POR2		OPOR2		POR3		OPOR3	
		Distance (m)	Noise Level at POR (dBA)	Distance (m)	Noise Level at POR (dBA)	Distance (m)	Noise Level at POR (dBA)	Distance (m)	Noise Level at POR (dBA)	Distance (m)	Noise Level at POR (dBA)	Distance (m)	Noise Level at POR (dBA)
BESS001	Battery Energy Storage System 001	1466	1	1451	1	439	11	409	11	414	7	384	7
BESS002	Battery Energy Storage System 002	1465	1	1449	1	440	12	411	11	416	10	387	9
BESS003	Battery Energy Storage System 003	1457	1	1441	1	449	14	419	13	428	14	399	14
BESS004	Battery Energy Storage System 004	1455	2	1439	2	451	18	420	18	430	14	401	14
BESS005	Battery Energy Storage System 005	1473	1	1457	2	445	8	416	9	419	7	389	7
BESS006	Battery Energy Storage System 006	1471	1	1456	2	447	11	417	11	421	9	392	9
BESS007	Battery Energy Storage System 007	1463	1	1448	2	455	16	425	16	433	16	403	15
BESS008	Battery Energy Storage System 008	1462	2	1446	2	457	18	427	18	435	16	406	16
BESS009	Battery Energy Storage System 009	1480	1	1464	1	452	9	423	9	424	9	394	9
BESS010	Battery Energy Storage System 010	1478	1	1463	2	454	11	424	11	426	10	397	10
BESS011	Battery Energy Storage System 011	1470	1	1454	2	462	17	432	16	438	16	408	15
BESS012	Battery Energy Storage System 012	1469	1	1453	2	464	18	434	18	440	16	411	16
BESS013	Battery Energy Storage System 013	1487	1	1471	1	459	9	430	9	429	9	399	9
BESS014	Battery Energy Storage System 014	1485	1	1469	1	461	11	431	10	431	10	402	10
BESS015	Battery Energy Storage System 015	1477	1	1461	2	469	16	439	16	443	16	413	15
BESS016	Battery Energy Storage System 016	1475	1	1460	2	470	16	441	18	445	16	416	16
BESS017	Battery Energy Storage System 017	1493	1	1478	1	466	9	436	9	434	8	405	9
BESS018	Battery Energy Storage System 018	1492	1	1476	1	467	11	438	10	436	10	407	10
BESS019	Battery Energy Storage System 019	1484	1	1468	2	475	16	446	16	448	16	418	15
BESS020	Battery Energy Storage System 020	1482	1	1466	2	477	16	447	16	450	16	421	15
BESS021	Battery Energy Storage System 021	1500	1	1484	1	473	9	443	9	439	8	410	9
BESS022	Battery Energy Storage System 022	1499	1	1483	1	474	10	445	10	442	10	412	10
BESS023	Battery Energy Storage System 023	1491	1	1475	1	482	15	453	15	453	16	423	15
BESS024	Battery Energy Storage System 024	1489	1	1473	1	484	16	454	16	455	16	426	15
BESS025	Battery Energy Storage System 025	1507	1	1491	1	480	9	450	9	445	8	415	9
BESS026	Battery Energy Storage System 026	1505	1	1489	1	481	10	452	10	447	10	418	10
BESS027	Battery Energy Storage System 027	1498	1	1481	1	489	15	459	14	458	16	429	15
BESS028	Battery Energy Storage System 028	1496	1	1480	1	491	15	461	15	460	16	431	15
BESS029	Battery Energy Storage System 029	1514	1	1498	1	487	9	458	9	450	8	421	9
BESS030	Battery Energy Storage System 030	1512	1	1496	1	488	10	459	10	452	10	423	10
BESS031	Battery Energy Storage System 031	1504	1	1488	1	496	15	466	14	463	15	434	15
BESS032	Battery Energy Storage System 032	1503	1	1487	1	497	15	468	15	466	16	436	15
BESS033	Battery Energy Storage System 033	1521	1	1505	1	494	9	465	9	456	9	426	9
BESS034	Battery Energy Storage System 034	1519	1	1503	1	495	10	466	10	458	10	429	10
BESS035	Battery Energy Storage System 035	1511	1	1495	1	503	15	473	14	469	15	439	15
BESS036	Battery Energy Storage System 036	1510	1	1494	1	504	15	475	14	471	16	442	15
BESS037	Battery Energy Storage System 037	1426	2	1410	2	441	12	410	12	430	12	401	9
BESS038	Battery Energy Storage System 038	1425	2	1409	2	443	13	412	13	432	14	403	13
BESS039	Battery Energy Storage System 039	1417	2	1401	2	453	18	422	16	445	18	416	19
BESS040	Battery Energy Storage System 040	1415	2	1399	2	454	18	424	16	447	17	419	17
BESS041	Battery Energy Storage System 041	1433	2	1417	2	447	11	417	11	434	10	405	9
BESS042	Battery Energy Storage System 042	1431	2	1416	2	449	13	419	13	437	12	407	10
BESS043	Battery Energy Storage System 043	1424	2	1408	2	459	19	428	17	449	16	420	17
BESS044	Battery Energy Storage System 044	1422	2	1406	2	461	19	430	17	452	17	423	17
BESS045	Battery Energy Storage System 045	1440	2	1424	2	454	12	423	12	439	8	409	9
BESS046	Battery Energy Storage System 046	1438	2	1422	2	455	14	425	13	441	10	412	10
BESS047	Battery Energy Storage System 047	1430	2	1414	2	465	16	434	17	453	16	424	16
BESS048	Battery Energy Storage System 048	1429	2	1413	2	467	17	436	17	456	17	427	16
BESS049	Battery Energy Storage System 049	1447	2	1431	2	460	12	430	12	443	8	414	9
BESS050	Battery Energy Storage System 050	1445	2	1429	2	462	14	431	14	445	10	416	10
BESS051	Battery Energy Storage System 051	1437	2	1421	2	471	16	440	17	458	16	429	15
BESS052	Battery Energy Storage System 052	1436	2	1420	2	473	16	442	17	460	16	431	16
BESS053	Battery Energy Storage System 053	1454	2	1438	2	466	12	436	12	448	8	418	9

Table E.1 Noise Impact Summary - Regular Operations

Source ID	Source Description	POR1		OPOR1		POR2		OPOR2		POR3		OPOR3	
		Distance (m)	Noise Level at POR (dBA)	Distance (m)	Noise Level at POR (dBA)	Distance (m)	Noise Level at POR (dBA)	Distance (m)	Noise Level at POR (dBA)	Distance (m)	Noise Level at POR (dBA)	Distance (m)	Noise Level at POR (dBA)
BESS054	Battery Energy Storage System 054	1452	2	1436	2	468	14	438	14	450	10	421	10
BESS055	Battery Energy Storage System 055	1444	2	1428	2	477	16	447	16	462	16	433	15
BESS056	Battery Energy Storage System 056	1443	2	1426	2	479	16	449	16	465	16	436	16
BESS057	Battery Energy Storage System 057	1460	2	1444	2	473	10	443	10	452	8	423	8
BESS058	Battery Energy Storage System 058	1459	2	1443	2	475	12	444	14	455	10	426	10
BESS059	Battery Energy Storage System 059	1451	2	1435	2	484	16	453	16	467	15	438	15
BESS060	Battery Energy Storage System 060	1450	2	1433	2	485	16	455	16	469	16	440	15
BESS061	Battery Energy Storage System 061	1467	2	1451	2	479	9	449	10	457	8	428	8
BESS062	Battery Energy Storage System 062	1466	2	1450	2	481	12	451	12	460	10	430	10
BESS063	Battery Energy Storage System 063	1458	2	1442	2	490	16	460	16	472	15	442	15
BESS064	Battery Energy Storage System 064	1456	2	1440	2	492	16	461	16	474	16	445	15
BESS065	Battery Energy Storage System 065	1474	1	1458	2	486	9	456	9	462	8	433	8
BESS066	Battery Energy Storage System 066	1473	1	1456	2	488	12	458	11	465	10	435	10
BESS067	Battery Energy Storage System 067	1465	2	1449	2	496	16	466	16	476	15	447	15
BESS068	Battery Energy Storage System 068	1463	2	1447	2	498	16	468	16	479	16	449	15
BESS069	Battery Energy Storage System 069	1481	1	1465	2	493	9	463	9	467	8	438	8
BESS070	Battery Energy Storage System 070	1479	1	1463	2	494	12	464	11	469	10	440	10
BESS071	Battery Energy Storage System 071	1472	2	1455	2	503	16	473	16	481	15	452	15
BESS072	Battery Energy Storage System 072	1470	2	1454	2	505	16	474	16	484	16	454	15
BESS073	Battery Energy Storage System 073	1488	1	1472	2	499	9	469	9	472	8	443	8
BESS074	Battery Energy Storage System 074	1486	1	1470	2	501	12	471	11	475	10	445	10
BESS075	Battery Energy Storage System 075	1479	1	1462	2	509	16	479	16	486	15	457	15
BESS076	Battery Energy Storage System 076	1477	1	1461	2	511	16	481	16	488	15	459	15
BESS077	Battery Energy Storage System 077	1495	1	1478	1	506	9	476	9	477	8	448	8
BESS078	Battery Energy Storage System 078	1493	1	1477	1	508	11	478	11	480	10	450	10
BESS079	Battery Energy Storage System 079	1486	1	1469	2	516	15	486	15	491	15	462	15
BESS080	Battery Energy Storage System 080	1484	1	1468	2	518	15	488	15	493	15	464	15
BESS081	Battery Energy Storage System 081	1502	1	1485	1	513	8	483	9	483	8	453	8
BESS082	Battery Energy Storage System 082	1500	1	1484	1	514	11	484	11	485	10	455	10
BESS083	Battery Energy Storage System 083	1493	1	1476	1	523	15	493	15	496	15	467	15
BESS084	Battery Energy Storage System 084	1491	1	1475	1	524	15	494	15	499	15	469	15
BESS085	Battery Energy Storage System 085	1393	1	1377	2	453	11	422	11	453	10	425	10
BESS086	Battery Energy Storage System 086	1392	1	1376	2	455	12	424	12	456	12	427	12
BESS087	Battery Energy Storage System 087	1384	1	1368	2	466	12	435	12	469	14	441	14
BESS088	Battery Energy Storage System 088	1382	2	1366	2	468	12	437	12	472	14	443	14
BESS089	Battery Energy Storage System 089	1400	2	1384	2	459	11	428	10	457	10	428	10
BESS090	Battery Energy Storage System 090	1399	2	1382	2	461	13	430	13	460	12	431	12
BESS091	Battery Energy Storage System 091	1391	2	1375	2	472	15	441	14	473	15	444	15
BESS092	Battery Energy Storage System 092	1389	2	1373	2	474	15	443	14	475	15	447	15
BESS093	Battery Energy Storage System 093	1407	2	1391	2	465	11	434	10	461	7	432	7
BESS094	Battery Energy Storage System 094	1405	2	1389	2	467	13	436	13	464	10	435	9
BESS095	Battery Energy Storage System 095	1398	2	1381	2	477	15	446	15	477	15	448	15
BESS096	Battery Energy Storage System 096	1396	2	1380	2	479	15	448	15	479	15	451	15
BESS097	Battery Energy Storage System 097	1414	2	1398	2	471	8	440	7	465	7	436	6
BESS098	Battery Energy Storage System 098	1412	2	1396	2	473	11	442	10	468	10	439	9
BESS099	Battery Energy Storage System 099	1405	2	1388	2	483	15	452	15	480	14	452	14
BESS100	Battery Energy Storage System 100	1403	2	1387	2	485	15	454	15	483	14	454	14
BESS101	Battery Energy Storage System 101	1421	2	1405	2	477	8	446	7	469	6	440	6
BESS102	Battery Energy Storage System 102	1419	2	1403	2	479	11	448	10	472	10	443	9
BESS103	Battery Energy Storage System 103	1412	2	1395	2	489	15	458	15	484	14	456	14
BESS104	Battery Energy Storage System 104	1410	2	1394	2	491	15	460	15	487	14	458	14
BESS105	Battery Energy Storage System 105	1428	2	1411	2	483	7	452	7	473	6	444	6
BESS106	Battery Energy Storage System 106	1426	2	1410	2	485	11	454	10	476	10	447	9

Table E.1 Noise Impact Summary - Regular Operations

Source ID	Source Description	POR1		OPOR1		POR2		OPOR2		POR3		OPOR3	
		Distance (m)	Noise Level at POR (dBA)	Distance (m)	Noise Level at POR (dBA)	Distance (m)	Noise Level at POR (dBA)	Distance (m)	Noise Level at POR (dBA)	Distance (m)	Noise Level at POR (dBA)	Distance (m)	Noise Level at POR (dBA)
BESS107	Battery Energy Storage System 107	1419	2	1402	2	495	14	464	14	489	14	460	14
BESS108	Battery Energy Storage System 108	1417	2	1401	2	497	14	466	14	491	14	462	14
BESS109	Battery Energy Storage System 109	1435	2	1418	2	489	7	458	7	478	6	449	5
BESS110	Battery Energy Storage System 110	1433	2	1417	2	491	11	460	10	480	9	451	8
BESS111	Battery Energy Storage System 111	1426	2	1409	2	501	14	470	14	493	14	464	14
BESS112	Battery Energy Storage System 112	1424	2	1408	2	503	14	472	14	495	14	466	14
BESS113	Battery Energy Storage System 113	1442	2	1425	2	495	7	465	7	482	6	453	5
BESS114	Battery Energy Storage System 114	1440	2	1424	2	497	10	467	10	485	8	456	8
BESS115	Battery Energy Storage System 115	1433	2	1416	2	507	14	476	14	497	14	468	12
BESS116	Battery Energy Storage System 116	1431	2	1415	2	509	14	478	14	500	14	471	13
BESS117	Battery Energy Storage System 117	1449	2	1432	2	501	7	471	7	487	6	458	5
BESS118	Battery Energy Storage System 118	1447	2	1431	2	503	10	473	10	489	8	460	8
BESS119	Battery Energy Storage System 119	1440	2	1423	2	513	14	482	14	501	13	472	12
BESS120	Battery Energy Storage System 120	1438	2	1421	2	515	14	484	14	504	13	475	13
BESS121	Battery Energy Storage System 121	1455	2	1439	2	508	7	477	7	491	6	462	5
BESS122	Battery Energy Storage System 122	1454	2	1437	2	510	10	479	10	494	8	465	8
BESS123	Battery Energy Storage System 123	1447	2	1430	2	519	14	488	14	506	13	477	12
BESS124	Battery Energy Storage System 124	1445	2	1428	2	521	14	490	14	508	13	479	13
BESS125	Battery Energy Storage System 125	1462	1	1446	2	514	7	484	7	496	6	467	5
BESS126	Battery Energy Storage System 126	1461	1	1444	2	516	10	485	10	498	8	469	8
BESS127	Battery Energy Storage System 127	1454	2	1437	2	525	14	495	13	511	13	481	12
BESS128	Battery Energy Storage System 128	1452	2	1435	2	527	14	497	14	513	13	484	13
BESS129	Battery Energy Storage System 129	1469	1	1453	2	520	7	490	7	501	6	472	5
BESS130	Battery Energy Storage System 130	1468	1	1451	2	522	10	492	10	503	8	474	8
BESS131	Battery Energy Storage System 131	1461	1	1444	2	531	14	501	13	515	13	486	12
BESS132	Battery Energy Storage System 132	1459	1	1442	2	533	14	503	13	518	13	488	12
BESS133	Battery Energy Storage System 133	1476	1	1460	2	527	7	497	7	506	6	476	5
BESS134	Battery Energy Storage System 134	1475	1	1458	2	529	10	498	10	508	8	479	8
BESS135	Battery Energy Storage System 135	1468	1	1451	2	538	14	507	13	520	13	491	12
BESS136	Battery Energy Storage System 136	1466	1	1449	2	540	14	509	13	522	13	493	12
BESS137	Battery Energy Storage System 137	1483	1	1467	2	533	7	503	7	511	5	481	5
BESS138	Battery Energy Storage System 138	1482	1	1465	2	535	10	505	10	513	8	484	8
BESS139	Battery Energy Storage System 139	1475	1	1458	2	544	14	514	13	525	13	495	12
BESS140	Battery Energy Storage System 140	1473	1	1456	2	546	14	515	13	527	13	498	12
BESS141	Battery Energy Storage System 141	1273	7	1257	7	408	11	377	11	446	10	421	11
BESS142	Battery Energy Storage System 142	1271	7	1255	7	410	15	380	13	449	12	424	15
BESS143	Battery Energy Storage System 143	1263	7	1247	7	423	20	393	16	464	19	439	19
BESS144	Battery Energy Storage System 144	1261	7	1246	7	426	20	396	16	467	20	442	19
BESS145	Battery Energy Storage System 145	1279	7	1264	7	412	12	381	12	448	10	423	10
BESS146	Battery Energy Storage System 146	1278	7	1262	7	415	13	384	13	451	14	426	14
BESS147	Battery Energy Storage System 147	1270	7	1254	7	427	17	397	17	466	16	440	16
BESS148	Battery Energy Storage System 148	1268	7	1252	7	430	17	399	18	468	16	443	16
BESS149	Battery Energy Storage System 149	1286	7	1270	7	416	11	386	11	450	10	424	10
BESS150	Battery Energy Storage System 150	1285	7	1269	7	419	13	388	13	453	14	427	14
BESS151	Battery Energy Storage System 151	1277	7	1261	7	431	17	401	17	467	16	442	16
BESS152	Battery Energy Storage System 152	1275	3	1259	3	434	17	403	17	470	16	445	16
BESS153	Battery Energy Storage System 153	1293	7	1277	7	420	11	390	11	452	10	426	10
BESS154	Battery Energy Storage System 154	1291	7	1275	7	423	13	392	13	455	14	429	14
BESS155	Battery Energy Storage System 155	1283	3	1267	3	435	17	405	17	469	16	443	16
BESS156	Battery Energy Storage System 156	1282	3	1266	3	438	17	407	17	472	16	446	16
BESS157	Battery Energy Storage System 157	1299	7	1284	7	425	11	394	11	454	10	428	10
BESS158	Battery Energy Storage System 158	1298	7	1282	7	427	13	396	13	457	14	431	14
BESS159	Battery Energy Storage System 159	1290	3	1274	3	440	17	409	17	471	16	445	16

Table E.1 Noise Impact Summary - Regular Operations

Source ID	Source Description	POR1		OPOR1		POR2		OPOR2		POR3		OPOR3	
		Distance (m)	Noise Level at POR (dBA)	Distance (m)	Noise Level at POR (dBA)	Distance (m)	Noise Level at POR (dBA)	Distance (m)	Noise Level at POR (dBA)	Distance (m)	Noise Level at POR (dBA)	Distance (m)	Noise Level at POR (dBA)
BESS160	Battery Energy Storage System 160	1288	3	1272	3	442	17	411	17	474	16	448	16
BESS161	Battery Energy Storage System 161	1306	7	1290	7	429	11	398	11	456	10	430	11
BESS162	Battery Energy Storage System 162	1305	7	1289	7	432	13	401	13	459	14	433	14
BESS163	Battery Energy Storage System 163	1297	3	1281	3	444	16	413	16	473	16	447	16
BESS164	Battery Energy Storage System 164	1295	3	1279	3	447	17	416	17	476	16	450	16
BESS165	Battery Energy Storage System 165	1313	3	1297	3	434	11	403	11	459	10	432	11
BESS166	Battery Energy Storage System 166	1311	3	1295	3	436	13	405	13	462	14	435	14
BESS167	Battery Energy Storage System 167	1304	3	1288	3	449	16	418	16	476	16	449	16
BESS168	Battery Energy Storage System 168	1302	3	1286	3	451	17	420	17	479	16	452	17
BESS169	Battery Energy Storage System 169	1320	3	1304	3	439	11	408	11	461	10	434	11
BESS170	Battery Energy Storage System 170	1318	3	1302	3	441	13	410	13	464	14	437	14
BESS171	Battery Energy Storage System 171	1311	3	1294	3	453	16	422	16	478	16	452	16
BESS172	Battery Energy Storage System 172	1309	3	1293	3	456	17	425	17	481	16	454	17
BESS173	Battery Energy Storage System 173	1327	3	1311	3	444	11	413	11	464	10	437	11
BESS174	Battery Energy Storage System 174	1325	3	1309	3	446	13	415	13	467	14	440	14
BESS175	Battery Energy Storage System 175	1317	3	1301	3	458	16	427	16	481	16	454	16
BESS176	Battery Energy Storage System 176	1316	3	1300	3	460	17	429	17	484	17	457	17
BESS177	Battery Energy Storage System 177	1334	3	1317	3	448	11	417	11	467	11	440	11
BESS178	Battery Energy Storage System 178	1332	3	1316	3	451	13	420	13	470	13	442	14
BESS179	Battery Energy Storage System 179	1324	3	1308	3	463	16	432	17	483	16	456	16
BESS180	Battery Energy Storage System 180	1323	3	1307	3	465	17	434	17	486	17	459	17
BESS181	Battery Energy Storage System 181	1340	3	1324	3	454	12	422	12	470	11	442	11
BESS182	Battery Energy Storage System 182	1339	3	1323	3	456	13	425	13	472	13	445	14
BESS183	Battery Energy Storage System 183	1331	3	1315	3	468	16	436	17	486	16	459	16
BESS184	Battery Energy Storage System 184	1330	3	1313	3	470	17	439	17	489	17	462	17
BESS185	Battery Energy Storage System 185	1347	3	1331	3	459	11	428	11	473	11	445	11
BESS186	Battery Energy Storage System 186	1346	3	1330	3	461	13	430	13	475	13	448	13
BESS187	Battery Energy Storage System 187	1338	3	1322	3	472	16	441	16	489	17	462	17
BESS188	Battery Energy Storage System 188	1337	3	1320	3	475	16	444	17	492	17	465	17
BESS189	Battery Energy Storage System 189	1251	7	1235	7	442	14	412	11	485	12	460	14
BESS190	Battery Energy Storage System 190	1243	7	1227	7	455	15	425	15	500	18	475	18
BESS191	Battery Energy Storage System 191	1242	7	1226	7	458	15	428	15	502	19	478	18
BESS192	Battery Energy Storage System 192	1260	7	1244	7	443	10	413	11	484	7	458	8
BESS193	Battery Energy Storage System 193	1258	7	1242	7	446	13	416	12	487	12	461	12
BESS194	Battery Energy Storage System 194	1250	7	1234	7	459	18	429	16	501	15	476	15
BESS195	Battery Energy Storage System 195	1249	7	1233	7	462	19	431	16	504	16	479	16
BESS196	Battery Energy Storage System 196	1267	7	1250	7	447	11	417	11	485	7	460	8
BESS197	Battery Energy Storage System 197	1265	7	1249	7	450	13	419	13	488	12	463	12
BESS198	Battery Energy Storage System 198	1257	7	1241	7	463	16	433	16	503	15	477	15
BESS199	Battery Energy Storage System 199	1256	3	1239	3	465	17	435	16	506	16	480	15
BESS200	Battery Energy Storage System 200	1273	7	1257	7	451	8	421	9	487	7	462	8
BESS201	Battery Energy Storage System 201	1272	7	1256	7	454	10	423	10	490	12	464	12
BESS202	Battery Energy Storage System 202	1264	3	1248	3	467	16	436	16	505	15	479	15
BESS203	Battery Energy Storage System 203	1263	3	1246	3	469	17	439	16	507	16	482	15
BESS204	Battery Energy Storage System 204	1280	7	1264	7	455	8	425	8	489	7	463	8
BESS205	Battery Energy Storage System 205	1279	7	1262	7	458	10	427	10	492	12	466	12
BESS206	Battery Energy Storage System 206	1271	3	1255	3	471	16	440	15	506	15	481	15
BESS207	Battery Energy Storage System 207	1270	3	1253	3	473	16	443	16	509	16	484	15
BESS208	Battery Energy Storage System 208	1287	7	1271	7	460	8	429	8	491	7	465	8
BESS209	Battery Energy Storage System 209	1286	7	1269	7	462	10	431	10	494	12	468	12
BESS210	Battery Energy Storage System 210	1278	3	1262	3	475	16	444	15	509	15	483	15
BESS211	Battery Energy Storage System 211	1277	3	1260	3	477	16	447	16	511	16	485	15
BESS212	Battery Energy Storage System 212	1294	7	1278	7	464	8	433	8	494	7	467	8

Table E.1 Noise Impact Summary - Regular Operations

Source ID	Source Description	POR1		OPOR1		POR2		OPOR2		POR3		OPOR3	
		Distance (m)	Noise Level at POR (dBA)	Distance (m)	Noise Level at POR (dBA)	Distance (m)	Noise Level at POR (dBA)	Distance (m)	Noise Level at POR (dBA)	Distance (m)	Noise Level at POR (dBA)	Distance (m)	Noise Level at POR (dBA)
BESS213	Battery Energy Storage System 213	1293	3	1276	3	466	10	436	10	496	12	470	12
BESS214	Battery Energy Storage System 214	1285	3	1269	3	479	16	448	15	511	15	484	15
BESS215	Battery Energy Storage System 215	1284	3	1267	3	482	16	451	16	514	16	487	16
BESS216	Battery Energy Storage System 216	1301	3	1285	3	468	8	438	8	496	7	469	8
BESS217	Battery Energy Storage System 217	1300	3	1283	3	471	10	440	10	499	12	472	12
BESS218	Battery Energy Storage System 218	1292	3	1276	3	483	16	453	15	513	15	487	15
BESS219	Battery Energy Storage System 219	1291	3	1274	3	486	16	455	16	516	16	489	16
BESS220	Battery Energy Storage System 220	1308	3	1292	3	473	8	442	8	498	7	472	8
BESS221	Battery Energy Storage System 221	1307	3	1290	3	475	10	445	10	501	12	474	12
BESS222	Battery Energy Storage System 222	1299	3	1282	3	488	16	457	15	515	15	489	15
BESS223	Battery Energy Storage System 223	1298	3	1281	3	490	16	459	16	518	16	492	16
BESS224	Battery Energy Storage System 224	1315	3	1298	3	478	8	447	8	501	7	474	8
BESS225	Battery Energy Storage System 225	1314	3	1297	3	480	10	449	10	504	10	477	13
BESS226	Battery Energy Storage System 226	1306	3	1289	3	492	15	461	15	518	15	491	15
BESS227	Battery Energy Storage System 227	1305	3	1288	3	495	16	464	15	521	16	494	16
BESS228	Battery Energy Storage System 228	1322	3	1305	3	482	8	451	8	504	7	477	8
BESS229	Battery Energy Storage System 229	1321	3	1304	3	485	10	454	10	506	10	479	13
BESS230	Battery Energy Storage System 230	1313	3	1296	3	497	15	466	15	520	15	493	15
BESS231	Battery Energy Storage System 231	1312	3	1295	3	499	16	468	15	523	16	496	16
BESS232	Battery Energy Storage System 232	1329	3	1312	3	487	8	456	8	507	7	479	8
BESS233	Battery Energy Storage System 233	1328	3	1311	3	490	10	459	10	509	10	482	10
BESS234	Battery Energy Storage System 234	1320	3	1303	3	502	15	471	15	523	15	496	15
BESS235	Battery Energy Storage System 235	1319	3	1302	3	504	16	473	15	526	16	499	16
BESS236	Battery Energy Storage System 236	1336	3	1319	3	492	8	461	8	509	7	482	8
BESS237	Battery Energy Storage System 237	1335	3	1318	3	494	10	463	10	512	10	485	10
BESS238	Battery Energy Storage System 238	1327	3	1310	3	506	15	475	15	526	15	499	15
BESS239	Battery Energy Storage System 239	1326	3	1309	3	509	16	478	15	529	16	501	16
BESS240	Battery Energy Storage System 240	1343	3	1326	3	497	8	466	8	512	7	485	8
BESS241	Battery Energy Storage System 241	1342	3	1325	3	499	10	468	10	515	10	488	10
BESS242	Battery Energy Storage System 242	1334	3	1317	3	511	15	480	15	529	15	501	15
BESS243	Battery Energy Storage System 243	1333	3	1316	3	513	16	482	15	532	16	504	16
BESS244	Battery Energy Storage System 244	1234	7	1218	7	472	10	442	7	518	9	493	9
BESS245	Battery Energy Storage System 245	1233	7	1216	7	475	18	445	14	521	11	496	11
BESS246	Battery Energy Storage System 246	1225	7	1208	7	488	14	458	14	535	15	511	15
BESS247	Battery Energy Storage System 247	1224	7	1207	7	491	19	461	14	538	16	514	14
BESS248	Battery Energy Storage System 248	1241	7	1224	7	476	10	446	7	519	5	494	5
BESS249	Battery Energy Storage System 249	1240	7	1223	7	478	12	448	8	522	8	497	8
BESS250	Battery Energy Storage System 250	1232	7	1215	7	492	14	462	13	537	13	512	13
BESS251	Battery Energy Storage System 251	1231	7	1214	7	494	15	464	13	540	14	515	13
BESS252	Battery Energy Storage System 252	1248	7	1231	7	479	6	449	5	521	5	496	5
BESS253	Battery Energy Storage System 253	1247	7	1230	7	482	12	452	8	524	8	499	8
BESS254	Battery Energy Storage System 254	1239	7	1222	7	495	14	465	13	538	13	513	13
BESS255	Battery Energy Storage System 255	1238	7	1221	7	498	14	468	13	541	13	516	13
BESS256	Battery Energy Storage System 256	1255	7	1238	7	483	6	453	5	523	5	497	5
BESS257	Battery Energy Storage System 257	1254	7	1237	7	486	9	455	8	526	8	500	8
BESS258	Battery Energy Storage System 258	1246	7	1229	7	499	14	469	12	540	13	515	13
BESS259	Battery Energy Storage System 259	1245	7	1228	7	501	14	471	13	543	13	518	13
BESS260	Battery Energy Storage System 260	1262	7	1245	7	487	6	456	6	525	5	499	5
BESS261	Battery Energy Storage System 261	1261	7	1244	7	489	9	459	8	527	8	502	8
BESS262	Battery Energy Storage System 262	1253	7	1236	7	503	14	472	12	542	13	516	13
BESS263	Battery Energy Storage System 263	1252	7	1235	7	505	14	475	13	545	13	519	13
BESS264	Battery Energy Storage System 264	1269	7	1252	7	491	6	460	5	526	5	501	5
BESS265	Battery Energy Storage System 265	1268	7	1251	7	493	9	463	8	529	8	503	8

Table E.1 Noise Impact Summary - Regular Operations

Source ID	Source Description	POR1		OPOR1		POR2		OPOR2		POR3		OPOR3	
		Distance (m)	Noise Level at POR (dBA)	Distance (m)	Noise Level at POR (dBA)	Distance (m)	Noise Level at POR (dBA)	Distance (m)	Noise Level at POR (dBA)	Distance (m)	Noise Level at POR (dBA)	Distance (m)	Noise Level at POR (dBA)
BESS266	Battery Energy Storage System 266	1260	7	1243	7	506	14	476	13	544	13	518	13
BESS267	Battery Energy Storage System 267	1259	7	1242	7	509	14	479	13	547	13	521	13
BESS268	Battery Energy Storage System 268	1276	7	1259	7	495	6	464	5	529	5	502	5
BESS269	Battery Energy Storage System 269	1275	7	1258	7	497	9	467	8	531	8	505	8
BESS270	Battery Energy Storage System 270	1267	7	1250	7	510	14	480	12	546	13	520	13
BESS271	Battery Energy Storage System 271	1266	7	1249	7	513	14	482	13	549	13	523	13
BESS272	Battery Energy Storage System 272	1283	7	1266	7	499	6	468	5	531	5	504	5
BESS273	Battery Energy Storage System 273	1282	7	1265	7	502	9	471	8	534	8	507	8
BESS274	Battery Energy Storage System 274	1275	7	1257	7	514	13	484	12	548	13	522	13
BESS275	Battery Energy Storage System 275	1273	7	1256	7	517	14	486	13	551	13	525	13
BESS276	Battery Energy Storage System 276	1290	7	1273	7	503	6	473	5	533	5	507	5
BESS277	Battery Energy Storage System 277	1289	7	1272	7	506	9	475	8	536	8	509	8
BESS278	Battery Energy Storage System 278	1282	6	1264	7	519	13	488	12	550	13	524	13
BESS279	Battery Energy Storage System 279	1280	6	1263	7	521	14	490	13	553	13	527	13
BESS280	Battery Energy Storage System 280	1297	7	1280	7	508	6	477	5	535	5	509	5
BESS281	Battery Energy Storage System 281	1296	7	1279	7	510	9	479	8	538	8	512	8
BESS282	Battery Energy Storage System 282	1289	6	1272	7	523	13	492	12	552	13	526	13
BESS283	Battery Energy Storage System 283	1287	6	1270	7	525	13	495	13	555	13	529	13
BESS284	Battery Energy Storage System 284	1304	7	1287	7	512	5	481	5	538	5	511	5
BESS285	Battery Energy Storage System 285	1303	7	1286	7	515	9	484	8	541	8	514	8
BESS286	Battery Energy Storage System 286	1296	6	1279	7	527	13	496	12	555	13	528	13
BESS287	Battery Energy Storage System 287	1295	6	1277	6	530	13	499	13	558	13	531	13
BESS288	Battery Energy Storage System 288	1311	7	1294	7	517	5	486	5	541	5	514	5
BESS289	Battery Energy Storage System 289	1310	7	1293	7	519	9	488	8	543	8	516	8
BESS290	Battery Energy Storage System 290	1303	6	1286	6	531	13	501	12	557	13	531	13
BESS291	Battery Energy Storage System 291	1302	6	1284	6	534	13	503	13	560	13	533	13
BESS292	Battery Energy Storage System 292	1318	7	1301	7	521	5	490	5	543	5	516	5
BESS293	Battery Energy Storage System 293	1317	7	1300	7	524	9	493	8	546	8	519	8
BESS294	Battery Energy Storage System 294	1310	6	1293	6	536	13	505	12	560	13	533	13
BESS295	Battery Energy Storage System 295	1309	6	1291	6	538	13	508	13	563	13	536	13
BESS296	Battery Energy Storage System 296	1326	7	1308	7	526	5	495	5	546	5	519	5
BESS297	Battery Energy Storage System 297	1324	6	1307	7	528	9	497	8	549	8	522	8
BESS298	Battery Energy Storage System 298	1317	6	1300	6	541	13	510	12	563	13	536	13
BESS299	Battery Energy Storage System 299	1316	6	1299	6	543	13	512	13	566	13	538	13
BESS300	Battery Energy Storage System 300	1333	6	1315	7	531	5	500	5	549	5	522	5
BESS301	Battery Energy Storage System 301	1331	6	1314	7	533	9	502	8	552	8	524	8
BESS302	Battery Energy Storage System 302	1324	6	1307	6	545	13	514	12	566	13	538	13
BESS303	Battery Energy Storage System 303	1323	6	1306	6	548	13	517	13	569	13	541	13
BESS304	Battery Energy Storage System 304	1419	1	1404	1	435	11	404	11	426	10	397	10
BESS305	Battery Energy Storage System 305	1418	1	1402	1	437	12	406	12	428	13	399	13
BESS306	Battery Energy Storage System 306	1410	1	1394	1	447	12	416	12	441	18	412	18
BESS307	Battery Energy Storage System 307	1408	2	1392	2	449	18	418	15	444	19	415	19
HVT001	Main Power Transformer 001	1403	15	1386	16	545	25	514	23	545	24	517	23
HVT002	Main Power Transformer 002	1427	15	1410	15	564	24	533	23	559	24	530	23
MVS001	Medium Voltage Substation 001	1461	1	1445	1	445	11	415	11	422	9	393	9
MVS002	Medium Voltage Substation 002	1467	2	1452	3	451	14	421	13	427	13	397	12
MVS003	Medium Voltage Substation 003	1474	2	1458	3	458	15	428	14	432	13	402	12
MVS004	Medium Voltage Substation 004	1481	2	1465	3	465	13	435	13	437	13	407	12
MVS005	Medium Voltage Substation 005	1488	2	1472	2	471	14	442	14	442	14	413	12
MVS006	Medium Voltage Substation 006	1495	2	1479	2	478	14	449	13	447	14	418	13
MVS007	Medium Voltage Substation 007	1501	2	1485	2	485	14	456	13	453	14	423	13
MVS008	Medium Voltage Substation 008	1508	2	1492	2	492	14	463	12	458	14	428	13
MVS009	Medium Voltage Substation 009	1515	2	1499	2	499	14	470	12	463	14	434	13

Table E.1 Noise Impact Summary - Regular Operations

Source ID	Source Description	POR1		OPOR1		POR2		OPOR2		POR3		OPOR3	
		Distance (m)	Noise Level at POR (dBA)	Distance (m)	Noise Level at POR (dBA)	Distance (m)	Noise Level at POR (dBA)	Distance (m)	Noise Level at POR (dBA)	Distance (m)	Noise Level at POR (dBA)	Distance (m)	Noise Level at POR (dBA)
MVS010	Medium Voltage Substation 010	1421	3	1405	3	448	14	417	14	439	15	410	15
MVS011	Medium Voltage Substation 011	1428	3	1412	3	454	15	423	14	443	15	414	13
MVS012	Medium Voltage Substation 012	1434	3	1418	3	460	16	430	16	447	13	418	12
MVS013	Medium Voltage Substation 013	1441	3	1425	3	466	16	436	16	452	13	422	13
MVS014	Medium Voltage Substation 014	1448	3	1432	3	473	16	442	15	456	13	427	12
MVS015	Medium Voltage Substation 015	1455	3	1439	3	479	15	449	15	461	13	432	12
MVS016	Medium Voltage Substation 016	1462	3	1446	3	485	15	455	15	466	12	436	12
MVS017	Medium Voltage Substation 017	1469	2	1452	3	492	15	462	14	470	13	441	12
MVS018	Medium Voltage Substation 018	1476	2	1459	3	499	14	468	14	475	12	446	11
MVS019	Medium Voltage Substation 019	1483	2	1466	3	505	14	475	14	480	12	451	11
MVS020	Medium Voltage Substation 020	1490	2	1473	2	512	14	482	14	485	12	456	11
MVS021	Medium Voltage Substation 021	1496	2	1480	2	518	14	488	13	491	13	461	12
MVS022	Medium Voltage Substation 022	1414	1	1398	1	442	11	411	11	435	13	406	13
MVS023	Medium Voltage Substation 023	1387	1	1371	1	460	11	429	11	462	12	434	13
MVS024	Medium Voltage Substation 024	1394	3	1378	3	466	14	435	14	466	14	438	14
MVS025	Medium Voltage Substation 025	1401	3	1385	3	472	15	441	15	470	14	441	13
MVS026	Medium Voltage Substation 026	1408	3	1392	3	478	15	447	15	474	12	445	13
MVS027	Medium Voltage Substation 027	1415	3	1398	3	484	14	453	14	478	12	449	12
MVS028	Medium Voltage Substation 028	1422	3	1405	3	490	14	459	14	482	12	453	12
MVS029	Medium Voltage Substation 029	1429	3	1412	3	496	14	465	13	486	12	457	11
MVS030	Medium Voltage Substation 030	1436	3	1419	3	502	14	471	13	491	11	462	10
MVS031	Medium Voltage Substation 031	1443	2	1426	3	508	14	477	13	495	11	466	10
MVS032	Medium Voltage Substation 032	1450	3	1433	3	514	14	483	13	500	11	471	10
MVS033	Medium Voltage Substation 033	1457	3	1440	3	520	14	490	13	504	11	475	10
MVS034	Medium Voltage Substation 034	1464	3	1447	3	527	14	496	13	509	11	480	10
MVS035	Medium Voltage Substation 035	1471	2	1454	3	533	14	503	13	514	11	485	10
MVS036	Medium Voltage Substation 036	1478	2	1462	3	540	14	509	13	519	11	490	10
MVS037	Medium Voltage Substation 037	1267	6	1251	6	417	20	387	16	457	16	432	16
MVS038	Medium Voltage Substation 038	1274	4	1258	4	421	17	390	15	458	15	433	15
MVS039	Medium Voltage Substation 039	1281	4	1265	4	425	15	395	14	460	15	435	15
MVS040	Medium Voltage Substation 040	1287	4	1271	4	429	15	398	15	462	15	436	15
MVS041	Medium Voltage Substation 041	1294	4	1278	4	433	15	403	14	464	15	438	15
MVS042	Medium Voltage Substation 042	1301	4	1285	4	438	15	407	14	466	15	440	15
MVS043	Medium Voltage Substation 043	1308	4	1291	4	442	14	412	14	469	15	442	15
MVS044	Medium Voltage Substation 044	1314	4	1298	4	447	14	416	14	471	15	444	15
MVS045	Medium Voltage Substation 045	1321	4	1305	4	452	14	421	14	474	15	447	15
MVS046	Medium Voltage Substation 046	1328	4	1312	4	457	15	426	14	477	15	449	15
MVS047	Medium Voltage Substation 047	1335	4	1319	4	462	15	431	14	479	15	452	15
MVS048	Medium Voltage Substation 048	1342	3	1326	4	467	15	436	14	482	15	455	15
MVS049	Medium Voltage Substation 049	1247	6	1231	6	449	15	419	16	492	15	467	15
MVS050	Medium Voltage Substation 050	1254	4	1238	4	452	15	422	13	494	14	469	13
MVS051	Medium Voltage Substation 051	1261	4	1245	4	456	15	426	14	496	13	470	13
MVS052	Medium Voltage Substation 052	1268	4	1252	4	460	13	430	13	497	13	472	13
MVS053	Medium Voltage Substation 053	1275	4	1259	4	464	14	434	13	499	13	473	13
MVS054	Medium Voltage Substation 054	1282	4	1265	4	469	13	438	13	501	13	475	13
MVS055	Medium Voltage Substation 055	1289	4	1272	4	473	13	442	12	504	13	477	13
MVS056	Medium Voltage Substation 056	1296	4	1279	4	477	13	446	12	506	13	479	13
MVS057	Medium Voltage Substation 057	1303	4	1286	4	482	12	451	12	508	13	482	13
MVS058	Medium Voltage Substation 058	1310	4	1293	4	486	12	455	12	511	14	484	13
MVS059	Medium Voltage Substation 059	1317	4	1300	4	491	12	460	12	513	14	486	13
MVS060	Medium Voltage Substation 060	1324	4	1307	4	495	12	464	12	516	14	489	13
MVS061	Medium Voltage Substation 061	1331	4	1314	4	500	12	469	12	519	14	492	13
MVS062	Medium Voltage Substation 062	1338	4	1321	4	505	12	474	12	522	14	495	13

Table E.1 Noise Impact Summary - Regular Operations

Source ID	Source Description	POR1		OPOR1		POR2		OPOR2		POR3		OPOR3	
		Distance (m)	Noise Level at POR (dBA)	Distance (m)	Noise Level at POR (dBA)	Distance (m)	Noise Level at POR (dBA)	Distance (m)	Noise Level at POR (dBA)	Distance (m)	Noise Level at POR (dBA)	Distance (m)	Noise Level at POR (dBA)
MVS063	Medium Voltage Substation 063	1229	6	1212	6	481	19	452	16	528	14	503	14
MVS064	Medium Voltage Substation 064	1236	4	1219	4	485	14	455	12	529	12	505	12
MVS065	Medium Voltage Substation 065	1243	4	1226	4	489	13	458	11	531	12	506	11
MVS066	Medium Voltage Substation 066	1250	4	1233	4	492	11	462	10	533	12	507	11
MVS067	Medium Voltage Substation 067	1257	4	1240	4	496	11	466	11	535	12	509	11
MVS068	Medium Voltage Substation 068	1264	4	1247	4	500	11	469	11	537	12	511	11
MVS069	Medium Voltage Substation 069	1271	4	1254	4	504	12	473	10	539	12	513	11
MVS070	Medium Voltage Substation 070	1278	4	1261	4	508	12	477	11	541	12	515	11
MVS071	Medium Voltage Substation 071	1285	4	1268	4	512	11	481	11	543	12	517	11
MVS072	Medium Voltage Substation 072	1292	4	1275	4	516	11	486	10	545	12	519	11
MVS073	Medium Voltage Substation 073	1299	4	1282	4	521	11	490	10	548	12	521	11
MVS074	Medium Voltage Substation 074	1306	3	1289	4	525	11	494	10	550	12	524	12
MVS075	Medium Voltage Substation 075	1314	3	1296	4	530	11	499	10	553	12	526	11
MVS076	Medium Voltage Substation 076	1321	3	1303	3	534	11	503	10	556	12	529	11
MVS077	Medium Voltage Substation 077	1328	3	1311	3	539	11	508	10	559	12	531	12
HVAC001	HVAC001	1457	17	1439	17	574	24	543	24	562	24	532	24

Table E.1 Noise Impact Summary - Regular Operations

Source ID	Source Description	POR4		OPOR4		POR5		OPOR5		POR6		OPOR6	
		Distance (m)	Noise Level at POR (dBA)	Distance (m)	Noise Level at POR (dBA)	Distance (m)	Noise Level at POR (dBA)	Distance (m)	Noise Level at POR (dBA)	Distance (m)	Noise Level at POR (dBA)	Distance (m)	Noise Level at POR (dBA)
BESS001	Battery Energy Storage System 001	441	7	411	7	729	12	701	12	1655	0	1625	0
BESS002	Battery Energy Storage System 002	444	11	414	11	729	12	701	12	1652	0	1623	0
BESS003	Battery Energy Storage System 003	459	13	429	13	729	17	702	12	1639	-2	1610	-2
BESS004	Battery Energy Storage System 004	462	15	432	15	730	17	702	12	1637	-2	1607	-3
BESS005	Battery Energy Storage System 005	440	7	410	7	721	12	693	12	1651	0	1621	0
BESS006	Battery Energy Storage System 006	443	12	413	12	721	12	693	12	1648	0	1619	0
BESS007	Battery Energy Storage System 007	457	13	427	13	721	17	694	12	1635	-2	1606	-2
BESS008	Battery Energy Storage System 008	460	13	430	13	722	17	694	12	1633	-2	1603	-3
BESS009	Battery Energy Storage System 009	438	7	408	7	713	12	685	12	1647	0	1618	0
BESS010	Battery Energy Storage System 010	441	11	411	11	713	12	685	12	1645	0	1615	0
BESS011	Battery Energy Storage System 011	456	13	426	13	713	16	686	12	1631	-2	1602	-2
BESS012	Battery Energy Storage System 012	458	13	428	13	713	17	686	12	1629	-2	1599	-3
BESS013	Battery Energy Storage System 013	437	7	407	8	705	12	677	12	1643	0	1614	0
BESS014	Battery Energy Storage System 014	440	12	410	13	705	12	677	12	1641	0	1611	0
BESS015	Battery Energy Storage System 015	454	14	424	14	705	16	678	12	1628	-2	1598	-2
BESS016	Battery Energy Storage System 016	457	14	427	14	705	16	678	12	1625	-2	1595	-3
BESS017	Battery Energy Storage System 017	435	8	405	8	697	11	669	11	1640	0	1610	0
BESS018	Battery Energy Storage System 018	438	13	408	13	697	11	669	11	1637	-1	1607	0
BESS019	Battery Energy Storage System 019	453	16	423	16	697	15	670	10	1624	-2	1594	-2
BESS020	Battery Energy Storage System 020	456	16	426	17	697	15	670	11	1621	-2	1592	-3
BESS021	Battery Energy Storage System 021	434	10	404	11	689	11	661	11	1636	0	1606	0
BESS022	Battery Energy Storage System 022	437	14	407	14	689	11	661	11	1633	-1	1604	-1
BESS023	Battery Energy Storage System 023	452	16	422	16	689	15	662	11	1620	-2	1590	-2
BESS024	Battery Energy Storage System 024	455	16	425	17	689	15	662	11	1617	-3	1588	-3
BESS025	Battery Energy Storage System 025	433	10	403	11	681	11	653	11	1632	0	1603	0
BESS026	Battery Energy Storage System 026	436	14	406	14	681	11	653	11	1629	-1	1600	-1
BESS027	Battery Energy Storage System 027	451	16	421	17	681	15	654	11	1616	-2	1587	-2
BESS028	Battery Energy Storage System 028	454	16	424	17	681	15	654	11	1614	-3	1584	-3
BESS029	Battery Energy Storage System 029	432	10	403	11	673	11	645	11	1628	0	1599	0
BESS030	Battery Energy Storage System 030	435	14	405	14	673	11	645	11	1626	0	1596	0
BESS031	Battery Energy Storage System 031	450	16	420	17	673	15	646	11	1613	-2	1583	-2
BESS032	Battery Energy Storage System 032	453	16	423	17	673	15	646	11	1610	-3	1580	-3
BESS033	Battery Energy Storage System 033	432	11	402	11	665	11	637	11	1625	0	1595	0
BESS034	Battery Energy Storage System 034	435	14	405	15	665	11	637	11	1622	0	1593	0
BESS035	Battery Energy Storage System 035	449	16	420	17	665	15	638	11	1609	0	1579	0
BESS036	Battery Energy Storage System 036	452	16	423	17	665	15	638	11	1606	0	1577	0
BESS037	Battery Energy Storage System 037	482	6	452	7	754	13	727	11	1635	0	1605	0
BESS038	Battery Energy Storage System 038	485	11	455	11	755	15	727	12	1633	0	1603	0
BESS039	Battery Energy Storage System 039	500	13	470	12	756	16	729	11	1620	-2	1590	-2
BESS040	Battery Energy Storage System 040	503	13	473	13	756	17	729	11	1617	-2	1587	-2
BESS041	Battery Energy Storage System 041	480	6	450	6	746	13	719	11	1631	0	1601	0
BESS042	Battery Energy Storage System 042	483	11	453	11	747	15	719	11	1628	0	1599	0
BESS043	Battery Energy Storage System 043	498	12	468	12	748	16	721	11	1616	-1	1586	-2
BESS044	Battery Energy Storage System 044	501	13	471	13	748	16	721	11	1613	-2	1583	-2
BESS045	Battery Energy Storage System 045	479	6	449	6	738	14	711	11	1627	0	1597	0
BESS046	Battery Energy Storage System 046	481	11	451	11	739	15	711	11	1624	0	1595	0
BESS047	Battery Energy Storage System 047	496	12	466	12	740	16	713	11	1612	-2	1582	-2
BESS048	Battery Energy Storage System 048	499	13	469	13	740	16	713	11	1609	-2	1579	-2
BESS049	Battery Energy Storage System 049	477	6	447	6	730	13	703	10	1623	0	1593	0
BESS050	Battery Energy Storage System 050	480	11	450	11	730	15	703	10	1620	0	1591	0
BESS051	Battery Energy Storage System 051	494	12	464	12	732	15	705	10	1608	-2	1578	-2
BESS052	Battery Energy Storage System 052	497	13	467	13	732	15	705	10	1605	-2	1575	-3
BESS053	Battery Energy Storage System 053	475	6	445	6	722	13	695	10	1619	0	1589	0

Table E.1 Noise Impact Summary - Regular Operations

Source ID	Source Description	POR4		OPOR4		POR5		OPOR5		POR6		OPOR6	
		Distance (m)	Noise Level at POR (dBA)	Distance (m)	Noise Level at POR (dBA)	Distance (m)	Noise Level at POR (dBA)	Distance (m)	Noise Level at POR (dBA)	Distance (m)	Noise Level at POR (dBA)	Distance (m)	Noise Level at POR (dBA)
BESS054	Battery Energy Storage System 054	478	11	448	11	722	15	695	10	1617	0	1587	0
BESS055	Battery Energy Storage System 055	493	12	463	12	724	15	697	10	1604	-2	1574	-2
BESS056	Battery Energy Storage System 056	496	13	466	13	724	15	697	10	1601	-2	1571	-3
BESS057	Battery Energy Storage System 057	474	7	444	7	714	15	687	10	1615	0	1586	0
BESS058	Battery Energy Storage System 058	477	11	447	11	714	15	687	10	1613	0	1583	0
BESS059	Battery Energy Storage System 059	491	13	461	12	715	15	689	10	1600	-2	1570	-2
BESS060	Battery Energy Storage System 060	494	13	464	13	716	15	689	10	1597	-2	1567	-3
BESS061	Battery Energy Storage System 061	473	7	443	7	706	15	679	10	1611	0	1582	0
BESS062	Battery Energy Storage System 062	475	12	445	12	706	15	679	10	1609	0	1579	0
BESS063	Battery Energy Storage System 063	490	14	460	14	707	15	681	10	1596	-2	1566	-2
BESS064	Battery Energy Storage System 064	493	15	463	15	708	15	681	10	1593	-2	1564	-2
BESS065	Battery Energy Storage System 065	471	7	441	8	698	15	671	10	1607	0	1578	0
BESS066	Battery Energy Storage System 066	474	12	444	13	698	15	671	10	1605	0	1575	0
BESS067	Battery Energy Storage System 067	489	15	459	15	699	15	673	10	1592	-2	1562	-2
BESS068	Battery Energy Storage System 068	492	15	462	15	700	15	673	10	1589	-2	1560	-2
BESS069	Battery Energy Storage System 069	470	7	440	8	690	15	663	10	1604	0	1574	0
BESS070	Battery Energy Storage System 070	473	12	443	13	690	15	663	10	1601	0	1571	0
BESS071	Battery Energy Storage System 071	488	15	458	15	691	15	665	10	1588	-2	1558	-2
BESS072	Battery Energy Storage System 072	491	15	461	15	692	15	665	10	1585	-2	1556	-3
BESS073	Battery Energy Storage System 073	469	7	440	8	682	15	655	10	1600	0	1570	0
BESS074	Battery Energy Storage System 074	472	12	442	13	682	15	655	10	1597	0	1568	0
BESS075	Battery Energy Storage System 075	487	15	457	15	683	15	657	10	1584	-2	1555	-2
BESS076	Battery Energy Storage System 076	490	15	460	15	684	15	657	10	1582	-2	1552	-3
BESS077	Battery Energy Storage System 077	469	8	439	8	674	15	647	10	1596	0	1567	0
BESS078	Battery Energy Storage System 078	471	12	442	13	674	15	647	10	1593	0	1564	0
BESS079	Battery Energy Storage System 079	486	15	457	15	675	15	649	10	1580	-2	1551	-2
BESS080	Battery Energy Storage System 080	489	15	459	15	676	15	649	10	1578	-2	1548	-2
BESS081	Battery Energy Storage System 081	468	8	438	9	666	15	639	11	1592	0	1563	0
BESS082	Battery Energy Storage System 082	471	12	441	13	666	15	639	10	1590	0	1560	0
BESS083	Battery Energy Storage System 083	486	15	456	16	667	15	641	10	1577	0	1547	0
BESS084	Battery Energy Storage System 084	489	15	459	16	668	15	641	10	1574	0	1544	0
BESS085	Battery Energy Storage System 085	522	3	492	4	773	12	747	11	1612	0	1582	0
BESS086	Battery Energy Storage System 086	525	5	495	6	774	13	747	11	1610	0	1580	0
BESS087	Battery Energy Storage System 087	539	11	509	11	775	16	749	11	1597	0	1567	0
BESS088	Battery Energy Storage System 088	542	11	512	11	776	16	750	11	1594	0	1565	0
BESS089	Battery Energy Storage System 089	520	3	490	4	765	12	739	11	1608	0	1578	1
BESS090	Battery Energy Storage System 090	523	5	493	6	766	13	739	11	1605	0	1576	1
BESS091	Battery Energy Storage System 091	537	10	507	9	767	16	741	11	1593	0	1563	1
BESS092	Battery Energy Storage System 092	540	10	510	10	768	16	742	11	1590	0	1560	1
BESS093	Battery Energy Storage System 093	518	3	488	4	757	12	731	11	1604	0	1574	1
BESS094	Battery Energy Storage System 094	521	5	491	6	758	13	731	11	1601	0	1571	1
BESS095	Battery Energy Storage System 095	535	10	505	9	759	16	733	11	1588	0	1559	1
BESS096	Battery Energy Storage System 096	538	10	508	10	760	16	734	11	1586	0	1556	1
BESS097	Battery Energy Storage System 097	516	3	486	4	749	12	723	10	1600	0	1570	1
BESS098	Battery Energy Storage System 098	519	5	489	6	750	13	723	11	1597	0	1567	1
BESS099	Battery Energy Storage System 099	533	10	503	9	751	16	725	11	1584	0	1555	1
BESS100	Battery Energy Storage System 100	536	10	506	10	752	16	726	11	1582	0	1552	1
BESS101	Battery Energy Storage System 101	514	3	484	4	741	11	715	10	1596	0	1566	1
BESS102	Battery Energy Storage System 102	517	5	487	6	742	12	715	10	1593	0	1563	1
BESS103	Battery Energy Storage System 103	532	10	502	9	743	15	717	10	1580	0	1550	1
BESS104	Battery Energy Storage System 104	534	10	504	10	744	15	718	10	1578	0	1548	1
BESS105	Battery Energy Storage System 105	513	3	483	4	733	12	707	10	1591	0	1562	1
BESS106	Battery Energy Storage System 106	515	5	485	6	734	13	707	10	1589	0	1559	1

Table E.1 Noise Impact Summary - Regular Operations

Source ID	Source Description	POR4		OPOR4		POR5		OPOR5		POR6		OPOR6	
		Distance (m)	Noise Level at POR (dBA)	Distance (m)	Noise Level at POR (dBA)	Distance (m)	Noise Level at POR (dBA)	Distance (m)	Noise Level at POR (dBA)	Distance (m)	Noise Level at POR (dBA)	Distance (m)	Noise Level at POR (dBA)
BESS107	Battery Energy Storage System 107	530	10	500	9	735	15	709	10	1576	1	1546	1
BESS108	Battery Energy Storage System 108	533	10	503	10	736	15	710	10	1574	1	1544	1
BESS109	Battery Energy Storage System 109	511	3	481	4	725	12	699	10	1587	0	1558	1
BESS110	Battery Energy Storage System 110	514	6	484	6	726	13	699	10	1585	0	1555	1
BESS111	Battery Energy Storage System 111	529	10	499	9	727	15	701	10	1572	1	1542	1
BESS112	Battery Energy Storage System 112	532	10	502	10	728	15	702	10	1569	1	1540	1
BESS113	Battery Energy Storage System 113	510	3	480	4	717	12	691	10	1583	0	1554	1
BESS114	Battery Energy Storage System 114	513	6	483	6	718	15	691	10	1581	0	1551	1
BESS115	Battery Energy Storage System 115	527	10	497	9	719	15	694	10	1568	1	1538	1
BESS116	Battery Energy Storage System 116	530	11	500	10	720	15	694	10	1565	1	1536	1
BESS117	Battery Energy Storage System 117	508	4	479	5	709	13	683	10	1579	0	1550	1
BESS118	Battery Energy Storage System 118	511	7	481	7	710	15	683	10	1577	0	1547	1
BESS119	Battery Energy Storage System 119	526	12	496	12	711	15	686	10	1564	1	1534	1
BESS120	Battery Energy Storage System 120	529	12	499	13	712	15	686	10	1561	1	1532	1
BESS121	Battery Energy Storage System 121	507	4	477	5	701	13	675	10	1576	0	1546	1
BESS122	Battery Energy Storage System 122	510	7	480	7	702	15	675	10	1573	0	1543	1
BESS123	Battery Energy Storage System 123	525	12	495	12	703	15	678	10	1560	1	1530	1
BESS124	Battery Energy Storage System 124	528	12	498	13	704	15	678	10	1557	1	1528	1
BESS125	Battery Energy Storage System 125	506	4	477	5	693	15	667	10	1572	0	1542	1
BESS126	Battery Energy Storage System 126	509	7	479	7	694	15	667	10	1569	0	1539	1
BESS127	Battery Energy Storage System 127	524	12	494	12	695	15	670	10	1556	0	1526	1
BESS128	Battery Energy Storage System 128	527	12	497	13	696	15	670	10	1553	0	1524	1
BESS129	Battery Energy Storage System 129	506	4	476	5	685	15	659	10	1568	0	1538	1
BESS130	Battery Energy Storage System 130	508	7	479	7	686	15	659	10	1565	0	1536	1
BESS131	Battery Energy Storage System 131	523	12	493	12	688	15	662	10	1552	0	1523	0
BESS132	Battery Energy Storage System 132	526	12	496	13	688	15	662	10	1550	0	1520	0
BESS133	Battery Energy Storage System 133	505	5	475	5	677	15	651	10	1564	0	1534	0
BESS134	Battery Energy Storage System 134	508	7	478	7	678	15	651	10	1561	0	1532	0
BESS135	Battery Energy Storage System 135	523	12	493	12	680	15	654	10	1548	0	1519	0
BESS136	Battery Energy Storage System 136	525	12	496	13	680	15	654	10	1546	0	1516	1
BESS137	Battery Energy Storage System 137	504	6	475	6	669	15	643	10	1560	0	1531	0
BESS138	Battery Energy Storage System 138	507	9	477	9	670	15	643	10	1558	0	1528	0
BESS139	Battery Energy Storage System 139	522	13	492	13	672	15	646	10	1544	0	1515	0
BESS140	Battery Energy Storage System 140	525	13	495	13	672	15	646	10	1542	0	1512	0
BESS141	Battery Energy Storage System 141	598	5	569	5	896	9	870	8	1648	0	1618	0
BESS142	Battery Energy Storage System 142	601	7	572	7	897	9	871	8	1645	0	1615	0
BESS143	Battery Energy Storage System 143	614	12	585	12	899	13	873	8	1633	-1	1603	-1
BESS144	Battery Energy Storage System 144	617	12	588	12	899	13	874	8	1631	-2	1601	-2
BESS145	Battery Energy Storage System 145	595	5	565	5	888	9	862	8	1643	0	1613	0
BESS146	Battery Energy Storage System 146	597	6	568	6	889	10	863	8	1641	0	1611	0
BESS147	Battery Energy Storage System 147	611	11	581	11	891	13	865	8	1629	-1	1599	-1
BESS148	Battery Energy Storage System 148	614	12	584	12	891	13	866	8	1626	-2	1596	-2
BESS149	Battery Energy Storage System 149	591	4	562	5	880	9	854	8	1638	0	1608	0
BESS150	Battery Energy Storage System 150	594	6	565	6	881	10	855	8	1636	0	1606	0
BESS151	Battery Energy Storage System 151	608	11	578	11	883	13	857	8	1624	-1	1594	-1
BESS152	Battery Energy Storage System 152	610	12	581	12	883	13	858	8	1621	-2	1591	-2
BESS153	Battery Energy Storage System 153	588	4	559	5	873	9	847	8	1634	0	1604	0
BESS154	Battery Energy Storage System 154	591	6	561	6	873	10	847	8	1632	0	1602	0
BESS155	Battery Energy Storage System 155	605	11	575	11	876	13	850	8	1619	-1	1590	-1
BESS156	Battery Energy Storage System 156	607	12	578	12	876	13	850	8	1617	-2	1587	-2
BESS157	Battery Energy Storage System 157	585	4	556	4	865	10	839	8	1629	0	1600	0
BESS158	Battery Energy Storage System 158	588	6	558	6	865	11	839	8	1627	0	1597	0
BESS159	Battery Energy Storage System 159	602	11	572	11	868	13	842	8	1615	-1	1585	-1

Table E.1 Noise Impact Summary - Regular Operations

Source ID	Source Description	POR4		OPOR4		POR5		OPOR5		POR6		OPOR6	
		Distance (m)	Noise Level at POR (dBA)	Distance (m)	Noise Level at POR (dBA)	Distance (m)	Noise Level at POR (dBA)	Distance (m)	Noise Level at POR (dBA)	Distance (m)	Noise Level at POR (dBA)	Distance (m)	Noise Level at POR (dBA)
BESS160	Battery Energy Storage System 160	604	12	575	12	868	13	842	8	1612	-2	1582	-2
BESS161	Battery Energy Storage System 161	582	4	552	4	857	10	831	8	1625	0	1595	0
BESS162	Battery Energy Storage System 162	585	6	555	6	857	11	832	8	1622	0	1593	0
BESS163	Battery Energy Storage System 163	599	11	569	11	860	13	834	8	1610	-1	1580	-1
BESS164	Battery Energy Storage System 164	601	12	572	11	860	13	835	8	1608	-2	1578	-2
BESS165	Battery Energy Storage System 165	579	4	549	4	849	10	823	8	1620	0	1590	0
BESS166	Battery Energy Storage System 166	582	6	552	6	849	14	824	8	1618	0	1588	0
BESS167	Battery Energy Storage System 167	596	11	566	11	852	9	826	8	1606	-1	1576	-1
BESS168	Battery Energy Storage System 168	598	11	569	11	852	13	827	8	1603	-2	1573	-2
BESS169	Battery Energy Storage System 169	576	4	546	4	841	11	815	8	1616	0	1586	0
BESS170	Battery Energy Storage System 170	579	6	549	6	841	14	816	9	1613	0	1583	0
BESS171	Battery Energy Storage System 171	593	11	563	11	844	9	818	8	1601	-1	1571	-1
BESS172	Battery Energy Storage System 172	596	11	566	11	844	13	819	8	1599	-2	1569	-2
BESS173	Battery Energy Storage System 173	573	4	544	4	833	12	807	8	1611	0	1581	0
BESS174	Battery Energy Storage System 174	576	6	546	6	833	14	808	9	1609	0	1579	0
BESS175	Battery Energy Storage System 175	590	11	560	11	836	13	810	8	1597	-1	1567	-1
BESS176	Battery Energy Storage System 176	593	12	563	11	836	13	811	8	1594	-2	1564	-2
BESS177	Battery Energy Storage System 177	571	5	541	5	825	14	799	9	1607	0	1577	0
BESS178	Battery Energy Storage System 178	573	6	544	6	825	14	800	9	1604	0	1575	0
BESS179	Battery Energy Storage System 179	588	11	558	11	828	13	802	9	1592	-1	1562	-1
BESS180	Battery Energy Storage System 180	590	12	560	12	828	14	803	9	1590	-2	1560	-2
BESS181	Battery Energy Storage System 181	568	5	538	6	817	14	791	9	1602	0	1573	0
BESS182	Battery Energy Storage System 182	571	7	541	7	818	14	792	9	1600	0	1570	0
BESS183	Battery Energy Storage System 183	585	12	555	12	820	14	794	9	1588	-1	1558	-1
BESS184	Battery Energy Storage System 184	588	12	558	13	820	14	795	9	1585	-2	1555	-2
BESS185	Battery Energy Storage System 185	566	7	536	7	809	14	783	9	1598	0	1568	1
BESS186	Battery Energy Storage System 186	568	8	539	8	810	14	784	9	1596	0	1566	1
BESS187	Battery Energy Storage System 187	583	14	553	14	812	14	786	9	1583	-1	1553	-1
BESS188	Battery Energy Storage System 188	585	14	556	14	812	9	787	9	1581	-2	1551	-2
BESS189	Battery Energy Storage System 189	634	6	605	6	903	8	878	8	1616	0	1586	0
BESS190	Battery Energy Storage System 190	648	11	618	11	905	8	880	8	1604	-1	1574	-1
BESS191	Battery Energy Storage System 191	650	11	621	11	906	8	881	8	1602	-2	1572	-2
BESS192	Battery Energy Storage System 192	628	4	599	4	894	8	869	7	1614	0	1584	0
BESS193	Battery Energy Storage System 193	631	5	601	6	895	8	870	8	1611	0	1581	0
BESS194	Battery Energy Storage System 194	644	11	615	11	898	8	873	8	1599	-1	1569	-1
BESS195	Battery Energy Storage System 195	647	11	618	11	898	8	873	8	1597	-2	1567	-2
BESS196	Battery Energy Storage System 196	625	4	595	4	886	8	861	7	1609	0	1579	0
BESS197	Battery Energy Storage System 197	628	5	598	5	887	8	862	8	1607	0	1577	0
BESS198	Battery Energy Storage System 198	641	11	612	11	890	8	865	8	1595	-1	1565	-1
BESS199	Battery Energy Storage System 199	644	11	614	11	890	8	865	8	1592	-2	1562	-2
BESS200	Battery Energy Storage System 200	622	4	592	4	879	8	853	7	1604	0	1574	0
BESS201	Battery Energy Storage System 201	625	5	595	5	879	8	854	8	1602	0	1572	0
BESS202	Battery Energy Storage System 202	638	11	609	10	882	8	857	8	1590	-1	1560	-1
BESS203	Battery Energy Storage System 203	641	11	611	11	882	9	857	8	1587	-2	1558	-2
BESS204	Battery Energy Storage System 204	619	4	589	4	871	8	845	7	1600	0	1570	0
BESS205	Battery Energy Storage System 205	622	5	592	5	871	9	846	8	1597	0	1567	0
BESS206	Battery Energy Storage System 206	635	11	606	10	874	8	849	8	1585	-1	1555	-1
BESS207	Battery Energy Storage System 207	638	11	608	11	874	9	850	8	1583	-2	1553	-2
BESS208	Battery Energy Storage System 208	616	4	586	4	863	9	837	7	1595	0	1565	0
BESS209	Battery Energy Storage System 209	619	5	589	5	863	9	838	8	1593	0	1563	0
BESS210	Battery Energy Storage System 210	633	11	603	10	866	9	841	8	1580	-1	1550	-1
BESS211	Battery Energy Storage System 211	635	11	606	11	867	9	842	8	1578	-2	1548	-2
BESS212	Battery Energy Storage System 212	613	4	583	4	855	9	830	8	1590	0	1560	0

Table E.1 Noise Impact Summary - Regular Operations

Source ID	Source Description	POR4		OPOR4		POR5		OPOR5		POR6		OPOR6	
		Distance (m)	Noise Level at POR (dBA)	Distance (m)	Noise Level at POR (dBA)	Distance (m)	Noise Level at POR (dBA)	Distance (m)	Noise Level at POR (dBA)	Distance (m)	Noise Level at POR (dBA)	Distance (m)	Noise Level at POR (dBA)
BESS213	Battery Energy Storage System 213	616	5	586	5	855	9	830	8	1588	0	1558	0
BESS214	Battery Energy Storage System 214	630	11	600	10	858	9	833	8	1576	-1	1546	-1
BESS215	Battery Energy Storage System 215	633	11	603	11	859	9	834	8	1573	-2	1543	-2
BESS216	Battery Energy Storage System 216	610	4	581	4	847	9	822	8	1586	0	1556	0
BESS217	Battery Energy Storage System 217	613	5	583	5	847	9	822	8	1583	0	1553	0
BESS218	Battery Energy Storage System 218	627	11	597	11	850	9	825	9	1571	-1	1541	-1
BESS219	Battery Energy Storage System 219	630	11	600	11	851	9	826	9	1569	-2	1539	-2
BESS220	Battery Energy Storage System 220	608	4	578	4	839	9	814	8	1581	0	1551	1
BESS221	Battery Energy Storage System 221	611	5	581	5	839	9	814	8	1579	0	1549	0
BESS222	Battery Energy Storage System 222	625	11	595	11	842	9	818	8	1567	-1	1537	-1
BESS223	Battery Energy Storage System 223	627	11	598	11	843	9	818	9	1564	-2	1534	-2
BESS224	Battery Energy Storage System 224	605	4	575	4	831	9	806	8	1577	0	1547	1
BESS225	Battery Energy Storage System 225	608	5	578	6	831	9	806	9	1574	0	1544	0
BESS226	Battery Energy Storage System 226	622	11	592	11	834	9	810	9	1562	-1	1532	-1
BESS227	Battery Energy Storage System 227	625	11	595	11	835	9	810	9	1560	-2	1530	-2
BESS228	Battery Energy Storage System 228	603	4	573	4	823	9	798	9	1572	0	1542	1
BESS229	Battery Energy Storage System 229	606	5	576	6	824	9	799	9	1570	0	1540	1
BESS230	Battery Energy Storage System 230	620	11	590	11	826	9	802	9	1557	-1	1527	-1
BESS231	Battery Energy Storage System 231	623	11	593	11	827	9	802	9	1555	-2	1525	-2
BESS232	Battery Energy Storage System 232	600	4	570	4	815	9	790	9	1568	0	1538	1
BESS233	Battery Energy Storage System 233	603	6	573	9	816	9	791	9	1565	0	1535	1
BESS234	Battery Energy Storage System 234	618	11	588	11	819	9	794	9	1553	-1	1523	-1
BESS235	Battery Energy Storage System 235	620	11	590	11	819	9	795	9	1550	-2	1521	-2
BESS236	Battery Energy Storage System 236	598	4	568	5	807	9	782	9	1563	0	1533	1
BESS237	Battery Energy Storage System 237	601	9	571	10	808	9	783	9	1561	1	1531	1
BESS238	Battery Energy Storage System 238	615	11	585	11	811	9	786	9	1548	-1	1518	-1
BESS239	Battery Energy Storage System 239	618	12	588	12	811	9	787	9	1546	-2	1516	-2
BESS240	Battery Energy Storage System 240	596	4	566	5	799	9	774	9	1559	0	1529	1
BESS241	Battery Energy Storage System 241	599	9	569	10	800	9	775	9	1556	0	1526	1
BESS242	Battery Energy Storage System 242	613	13	583	13	803	9	778	9	1544	-1	1514	-1
BESS243	Battery Energy Storage System 243	616	13	586	14	803	9	779	9	1541	-2	1512	-2
BESS244	Battery Energy Storage System 244	665	1	635	2	909	8	885	7	1589	0	1559	0
BESS245	Battery Energy Storage System 245	667	4	638	4	910	8	885	8	1587	0	1557	0
BESS246	Battery Energy Storage System 246	681	8	652	8	913	8	889	8	1575	0	1545	0
BESS247	Battery Energy Storage System 247	684	8	654	8	914	8	889	8	1573	0	1543	0
BESS248	Battery Energy Storage System 248	662	1	632	2	901	8	877	7	1584	0	1555	0
BESS249	Battery Energy Storage System 249	664	4	635	4	902	8	877	8	1582	0	1552	0
BESS250	Battery Energy Storage System 250	678	8	648	8	905	8	881	8	1570	0	1540	0
BESS251	Battery Energy Storage System 251	681	8	651	8	906	8	882	8	1568	0	1538	0
BESS252	Battery Energy Storage System 252	659	1	629	1	893	8	869	7	1580	0	1550	0
BESS253	Battery Energy Storage System 253	661	4	632	4	894	8	870	8	1577	0	1547	0
BESS254	Battery Energy Storage System 254	675	8	645	8	897	8	873	8	1565	0	1535	0
BESS255	Battery Energy Storage System 255	678	8	648	8	898	8	874	8	1563	0	1533	0
BESS256	Battery Energy Storage System 256	656	1	626	1	886	8	861	7	1575	0	1545	0
BESS257	Battery Energy Storage System 257	658	4	629	4	886	8	862	8	1573	0	1543	0
BESS258	Battery Energy Storage System 258	672	8	643	8	889	8	865	8	1561	0	1531	0
BESS259	Battery Energy Storage System 259	675	8	645	8	890	8	866	8	1558	0	1528	0
BESS260	Battery Energy Storage System 260	653	1	623	1	878	8	853	7	1570	0	1540	0
BESS261	Battery Energy Storage System 261	656	4	626	4	878	8	854	8	1568	0	1538	0
BESS262	Battery Energy Storage System 262	670	8	640	8	882	8	858	8	1556	0	1526	0
BESS263	Battery Energy Storage System 263	672	8	643	8	882	8	858	8	1553	0	1523	0
BESS264	Battery Energy Storage System 264	650	1	620	1	870	8	845	7	1565	0	1535	0
BESS265	Battery Energy Storage System 265	653	4	623	4	870	8	846	8	1563	0	1533	0

Table E.1 Noise Impact Summary - Regular Operations

Source ID	Source Description	POR4		OPOR4		POR5		OPOR5		POR6		OPOR6	
		Distance (m)	Noise Level at POR (dBA)	Distance (m)	Noise Level at POR (dBA)	Distance (m)	Noise Level at POR (dBA)	Distance (m)	Noise Level at POR (dBA)	Distance (m)	Noise Level at POR (dBA)	Distance (m)	Noise Level at POR (dBA)
BESS266	Battery Energy Storage System 266	667	8	637	8	874	9	850	8	1551	0	1521	0
BESS267	Battery Energy Storage System 267	670	8	640	8	874	8	850	8	1549	0	1519	0
BESS268	Battery Energy Storage System 268	647	1	618	1	862	9	838	7	1561	0	1531	0
BESS269	Battery Energy Storage System 269	650	4	620	4	863	9	838	8	1558	0	1528	0
BESS270	Battery Energy Storage System 270	664	8	634	8	866	9	842	8	1546	0	1516	0
BESS271	Battery Energy Storage System 271	667	8	637	8	867	9	843	8	1544	0	1514	0
BESS272	Battery Energy Storage System 272	645	1	615	2	854	9	830	7	1556	0	1526	1
BESS273	Battery Energy Storage System 273	648	4	618	4	855	9	830	8	1554	0	1524	1
BESS274	Battery Energy Storage System 274	662	8	632	8	858	9	834	8	1541	0	1512	0
BESS275	Battery Energy Storage System 275	665	8	635	8	859	9	835	8	1539	0	1509	0
BESS276	Battery Energy Storage System 276	642	1	612	2	846	9	822	7	1551	0	1521	1
BESS277	Battery Energy Storage System 277	645	4	615	4	847	9	823	8	1549	0	1519	1
BESS278	Battery Energy Storage System 278	659	8	629	8	850	9	826	8	1537	0	1507	0
BESS279	Battery Energy Storage System 279	662	8	632	8	851	9	827	8	1534	0	1504	0
BESS280	Battery Energy Storage System 280	640	1	610	2	838	9	814	7	1547	0	1517	1
BESS281	Battery Energy Storage System 281	643	4	613	4	839	9	815	8	1544	0	1514	1
BESS282	Battery Energy Storage System 282	657	8	627	8	842	9	819	8	1532	0	1502	0
BESS283	Battery Energy Storage System 283	660	8	630	8	843	9	819	8	1530	0	1500	0
BESS284	Battery Energy Storage System 284	638	1	608	2	830	9	806	7	1542	0	1512	1
BESS285	Battery Energy Storage System 285	640	4	610	4	831	9	807	8	1540	0	1510	1
BESS286	Battery Energy Storage System 286	655	8	625	8	835	9	811	8	1527	0	1498	0
BESS287	Battery Energy Storage System 287	658	8	628	8	835	9	812	9	1525	0	1495	0
BESS288	Battery Energy Storage System 288	635	1	605	2	823	9	798	8	1538	0	1508	1
BESS289	Battery Energy Storage System 289	638	4	608	4	823	9	799	9	1535	0	1505	1
BESS290	Battery Energy Storage System 290	653	8	623	8	827	9	803	9	1523	0	1493	1
BESS291	Battery Energy Storage System 291	655	8	625	8	828	9	804	9	1520	0	1490	1
BESS292	Battery Energy Storage System 292	633	1	603	2	815	9	791	8	1533	0	1503	1
BESS293	Battery Energy Storage System 293	636	4	606	4	815	9	791	9	1531	0	1501	1
BESS294	Battery Energy Storage System 294	651	8	621	8	819	9	795	9	1518	0	1488	1
BESS295	Battery Energy Storage System 295	653	8	623	8	820	9	796	9	1516	0	1486	1
BESS296	Battery Energy Storage System 296	631	1	601	2	807	9	783	9	1528	0	1499	1
BESS297	Battery Energy Storage System 297	634	4	604	4	808	9	784	9	1526	0	1496	1
BESS298	Battery Energy Storage System 298	649	8	619	8	811	9	788	9	1514	0	1484	1
BESS299	Battery Energy Storage System 299	651	8	621	8	812	9	788	9	1511	0	1481	1
BESS300	Battery Energy Storage System 300	629	1	599	2	799	9	775	9	1524	1	1494	1
BESS301	Battery Energy Storage System 301	632	4	602	4	800	9	776	9	1522	0	1492	1
BESS302	Battery Energy Storage System 302	647	11	617	11	803	9	780	9	1509	0	1479	1
BESS303	Battery Energy Storage System 303	650	11	620	11	804	9	781	9	1507	0	1477	1
BESS304	Battery Energy Storage System 304	485	7	455	7	762	13	735	12	1639	0	1609	0
BESS305	Battery Energy Storage System 305	488	12	458	12	763	15	735	12	1636	0	1607	0
BESS306	Battery Energy Storage System 306	502	13	472	13	764	17	737	12	1624	-2	1594	-2
BESS307	Battery Energy Storage System 307	505	14	475	14	764	17	737	12	1621	-2	1591	-2
HVT001	Main Power Transformer 001	585	22	555	22	732	20	707	20	1520	11	1490	12
HVT002	Main Power Transformer 002	581	22	551	23	705	20	681	20	1506	12	1476	12
MVS001	Medium Voltage Substation 001	451	11	421	11	729	13	702	13	1646	0	1616	0
MVS002	Medium Voltage Substation 002	450	11	420	11	721	13	693	13	1642	0	1612	0
MVS003	Medium Voltage Substation 003	448	10	418	11	713	13	685	12	1638	0	1608	0
MVS004	Medium Voltage Substation 004	447	11	417	11	705	13	677	12	1634	0	1605	0
MVS005	Medium Voltage Substation 005	446	14	416	15	697	12	669	12	1630	0	1601	0
MVS006	Medium Voltage Substation 006	444	14	415	16	689	12	661	12	1627	0	1597	0
MVS007	Medium Voltage Substation 007	443	15	414	16	681	12	653	12	1623	0	1593	0
MVS008	Medium Voltage Substation 008	443	15	413	16	673	12	645	12	1619	0	1590	0
MVS009	Medium Voltage Substation 009	442	16	412	16	665	12	637	11	1615	1	1586	1

Table E.1 Noise Impact Summary - Regular Operations

Source ID	Source Description	POR4		OPOR4		POR5		OPOR5		POR6		OPOR6	
		Distance (m)	Noise Level at POR (dBA)	Distance (m)	Noise Level at POR (dBA)	Distance (m)	Noise Level at POR (dBA)	Distance (m)	Noise Level at POR (dBA)	Distance (m)	Noise Level at POR (dBA)	Distance (m)	Noise Level at POR (dBA)
MVS010	Medium Voltage Substation 010	493	10	463	10	755	13	728	12	1626	0	1596	0
MVS011	Medium Voltage Substation 011	491	10	461	10	747	12	720	11	1622	0	1592	0
MVS012	Medium Voltage Substation 012	489	10	459	10	739	14	712	12	1618	0	1588	0
MVS013	Medium Voltage Substation 013	487	10	457	10	731	14	704	11	1614	0	1584	0
MVS014	Medium Voltage Substation 014	485	10	455	10	723	14	696	11	1610	0	1580	0
MVS015	Medium Voltage Substation 015	484	10	454	10	715	14	688	12	1606	0	1576	0
MVS016	Medium Voltage Substation 016	483	11	453	11	707	14	680	12	1602	0	1573	0
MVS017	Medium Voltage Substation 017	482	12	452	12	699	14	672	12	1598	0	1569	0
MVS018	Medium Voltage Substation 018	481	12	451	13	691	14	664	12	1594	0	1565	0
MVS019	Medium Voltage Substation 019	480	13	450	13	683	14	656	12	1591	0	1561	0
MVS020	Medium Voltage Substation 020	479	13	449	13	675	14	648	12	1587	0	1557	1
MVS021	Medium Voltage Substation 021	478	14	449	14	667	15	640	11	1583	1	1554	2
MVS022	Medium Voltage Substation 022	495	10	465	10	763	13	736	12	1630	0	1600	0
MVS023	Medium Voltage Substation 023	532	10	502	10	775	13	749	12	1603	0	1573	1
MVS024	Medium Voltage Substation 024	530	10	500	10	767	13	741	12	1599	1	1569	1
MVS025	Medium Voltage Substation 025	528	10	498	10	759	12	733	11	1595	1	1565	0
MVS026	Medium Voltage Substation 026	526	10	496	10	751	12	725	11	1591	0	1561	0
MVS027	Medium Voltage Substation 027	525	10	495	10	743	12	717	11	1587	0	1557	0
MVS028	Medium Voltage Substation 028	523	10	493	10	735	12	709	11	1583	0	1553	0
MVS029	Medium Voltage Substation 029	522	10	492	10	727	12	701	11	1578	0	1549	0
MVS030	Medium Voltage Substation 030	520	10	490	10	719	12	693	11	1574	0	1545	0
MVS031	Medium Voltage Substation 031	519	12	489	12	711	12	685	11	1570	0	1541	0
MVS032	Medium Voltage Substation 032	518	12	488	12	703	12	677	12	1566	0	1537	0
MVS033	Medium Voltage Substation 033	517	12	487	12	695	12	669	12	1563	0	1533	0
MVS034	Medium Voltage Substation 034	516	12	486	12	687	12	661	12	1559	0	1529	0
MVS035	Medium Voltage Substation 035	515	12	486	12	679	12	653	12	1555	0	1525	0
MVS036	Medium Voltage Substation 036	515	12	485	13	671	12	645	11	1551	1	1521	1
MVS037	Medium Voltage Substation 037	607	10	578	9	898	9	872	8	1639	0	1609	0
MVS038	Medium Voltage Substation 038	604	9	575	9	890	10	864	9	1635	0	1605	0
MVS039	Medium Voltage Substation 039	601	9	571	9	882	10	856	9	1630	-1	1600	-1
MVS040	Medium Voltage Substation 040	598	9	568	9	874	10	849	9	1626	0	1596	0
MVS041	Medium Voltage Substation 041	595	9	565	9	866	10	841	9	1621	0	1591	0
MVS042	Medium Voltage Substation 042	592	9	562	9	858	10	833	9	1616	0	1586	0
MVS043	Medium Voltage Substation 043	589	9	559	9	850	10	825	10	1612	0	1582	0
MVS044	Medium Voltage Substation 044	586	9	556	9	843	11	817	10	1607	0	1577	0
MVS045	Medium Voltage Substation 045	583	9	553	9	835	11	809	10	1603	0	1573	0
MVS046	Medium Voltage Substation 046	581	9	551	9	827	11	801	9	1598	0	1568	0
MVS047	Medium Voltage Substation 047	578	9	548	9	819	13	793	9	1594	0	1564	0
MVS048	Medium Voltage Substation 048	576	12	546	12	811	12	785	10	1589	0	1559	0
MVS049	Medium Voltage Substation 049	641	9	611	8	904	8	879	7	1610	-1	1580	-1
MVS050	Medium Voltage Substation 050	638	8	608	8	896	9	871	8	1605	-1	1575	-1
MVS051	Medium Voltage Substation 051	634	8	605	8	888	9	863	8	1601	-1	1571	-1
MVS052	Medium Voltage Substation 052	631	8	602	8	880	9	855	8	1596	0	1566	0
MVS053	Medium Voltage Substation 053	628	8	599	8	872	9	847	8	1591	0	1561	0
MVS054	Medium Voltage Substation 054	626	8	596	8	865	9	840	8	1587	0	1557	0
MVS055	Medium Voltage Substation 055	623	8	593	8	857	9	832	9	1582	0	1552	0
MVS056	Medium Voltage Substation 056	620	8	590	8	849	10	824	9	1577	1	1547	0
MVS057	Medium Voltage Substation 057	618	8	588	8	841	10	816	9	1573	1	1543	1
MVS058	Medium Voltage Substation 058	615	8	585	8	833	10	808	9	1568	1	1538	1
MVS059	Medium Voltage Substation 059	613	8	583	8	825	10	800	9	1564	1	1534	1
MVS060	Medium Voltage Substation 060	610	8	580	8	817	10	792	9	1559	1	1529	1
MVS061	Medium Voltage Substation 061	608	8	578	8	809	10	784	10	1555	1	1525	1
MVS062	Medium Voltage Substation 062	606	10	576	10	801	10	777	10	1550	2	1520	2

Table E.1 Noise Impact Summary - Regular Operations

Source ID	Source Description	POR4		OPOR4		POR5		OPOR5		POR6		OPOR6	
		Distance (m)	Noise Level at POR (dBA)	Distance (m)	Noise Level at POR (dBA)	Distance (m)	Noise Level at POR (dBA)	Distance (m)	Noise Level at POR (dBA)	Distance (m)	Noise Level at POR (dBA)	Distance (m)	Noise Level at POR (dBA)
MVS063	Medium Voltage Substation 063	674	7	645	7	911	8	887	8	1581	0	1551	1
MVS064	Medium Voltage Substation 064	671	7	642	7	903	9	879	8	1576	0	1546	1
MVS065	Medium Voltage Substation 065	668	7	639	7	896	9	871	8	1571	0	1541	1
MVS066	Medium Voltage Substation 066	665	7	636	7	888	9	863	8	1567	0	1537	1
MVS067	Medium Voltage Substation 067	663	7	633	7	880	9	856	8	1562	0	1532	1
MVS068	Medium Voltage Substation 068	660	7	630	7	872	9	848	8	1557	0	1527	1
MVS069	Medium Voltage Substation 069	657	7	627	7	864	9	840	9	1552	0	1522	1
MVS070	Medium Voltage Substation 070	655	7	625	7	856	9	832	9	1548	0	1518	1
MVS071	Medium Voltage Substation 071	652	7	622	7	849	10	824	9	1543	0	1513	1
MVS072	Medium Voltage Substation 072	650	7	620	7	841	10	817	9	1538	0	1508	1
MVS073	Medium Voltage Substation 073	648	7	618	7	833	10	809	9	1534	1	1504	1
MVS074	Medium Voltage Substation 074	645	7	615	7	825	9	801	9	1529	1	1499	1
MVS075	Medium Voltage Substation 075	643	7	613	7	817	9	793	9	1524	1	1494	1
MVS076	Medium Voltage Substation 076	641	7	611	7	809	9	786	9	1520	1	1490	1
MVS077	Medium Voltage Substation 077	639	9	609	9	802	10	778	9	1515	1	1485	1
HVAC001	HVAC001	565	23	536	24	677	26	652	25	1505	13	1475	13

Table E.1 Noise Impact Summary - Regular Operations

Source ID	Source Description	POR7		OPOR7		POR8		OPOR8		VL1	
		Distance (m)	Noise Level at POR (dBA)	Distance (m)	Noise Level at POR (dBA)	Distance (m)	Noise Level at POR (dBA)	Distance (m)	Noise Level at POR (dBA)	Distance (m)	Noise Level at POR (dBA)
BESS001	Battery Energy Storage System 001	197	14	174	14	852	5	822	6	464	7
BESS002	Battery Energy Storage System 002	200	14	177	15	852	5	823	6	467	9
BESS003	Battery Energy Storage System 003	215	17	191	14	855	6	825	6	477	16
BESS004	Battery Energy Storage System 004	218	17	194	14	855	6	825	6	480	16
BESS005	Battery Energy Storage System 005	198	14	176	12	860	8	830	8	470	8
BESS006	Battery Energy Storage System 006	201	15	179	13	860	8	831	8	472	10
BESS007	Battery Energy Storage System 007	216	16	193	14	863	8	833	8	483	14
BESS008	Battery Energy Storage System 008	219	17	196	14	863	8	833	8	485	14
BESS009	Battery Energy Storage System 009	200	14	178	12	868	8	838	8	476	8
BESS010	Battery Energy Storage System 010	202	15	181	13	868	8	839	8	478	10
BESS011	Battery Energy Storage System 011	217	16	195	14	871	8	841	8	488	15
BESS012	Battery Energy Storage System 012	220	17	198	14	871	8	841	8	491	14
BESS013	Battery Energy Storage System 013	201	14	181	12	876	8	846	8	481	8
BESS014	Battery Energy Storage System 014	204	15	184	13	876	8	847	8	483	10
BESS015	Battery Energy Storage System 015	219	16	198	14	879	8	849	8	494	15
BESS016	Battery Energy Storage System 016	222	16	200	14	879	8	849	8	496	15
BESS017	Battery Energy Storage System 017	203	14	184	12	884	8	854	8	487	8
BESS018	Battery Energy Storage System 018	206	15	186	13	884	8	855	8	489	10
BESS019	Battery Energy Storage System 019	221	16	200	14	886	8	857	8	500	15
BESS020	Battery Energy Storage System 020	223	16	203	14	887	8	857	8	502	15
BESS021	Battery Energy Storage System 021	206	11	187	11	892	7	862	8	493	8
BESS022	Battery Energy Storage System 022	209	15	190	13	892	8	863	8	495	10
BESS023	Battery Energy Storage System 023	223	16	203	14	894	8	865	8	505	15
BESS024	Battery Energy Storage System 024	226	16	206	14	895	8	865	8	507	15
BESS025	Battery Energy Storage System 025	208	11	191	10	900	7	870	8	499	7
BESS026	Battery Energy Storage System 026	211	14	193	13	900	7	871	8	501	9
BESS027	Battery Energy Storage System 027	225	16	207	14	902	7	873	8	511	15
BESS028	Battery Energy Storage System 028	228	16	209	14	903	8	873	8	513	15
BESS029	Battery Energy Storage System 029	211	11	194	11	908	7	878	8	505	7
BESS030	Battery Energy Storage System 030	214	15	197	13	908	7	879	8	507	10
BESS031	Battery Energy Storage System 031	228	16	210	14	910	7	881	8	517	14
BESS032	Battery Energy Storage System 032	231	17	213	14	911	7	881	8	519	15
BESS033	Battery Energy Storage System 033	215	12	198	12	916	7	886	8	511	8
BESS034	Battery Energy Storage System 034	217	15	201	13	916	7	887	8	513	10
BESS035	Battery Energy Storage System 035	231	16	214	14	918	7	889	8	523	14
BESS036	Battery Energy Storage System 036	234	17	216	14	919	7	889	8	525	15
BESS037	Battery Energy Storage System 037	232	13	206	11	834	8	804	8	476	10
BESS038	Battery Energy Storage System 038	235	14	209	12	834	8	804	8	478	12
BESS039	Battery Energy Storage System 039	250	16	224	14	837	8	807	8	490	18
BESS040	Battery Energy Storage System 040	253	16	227	14	838	8	808	8	492	18
BESS041	Battery Energy Storage System 041	232	13	207	11	842	8	812	8	481	10
BESS042	Battery Energy Storage System 042	235	14	210	12	842	8	812	8	483	12
BESS043	Battery Energy Storage System 043	250	16	225	14	845	8	815	8	495	16
BESS044	Battery Energy Storage System 044	253	16	228	14	846	8	816	9	497	16
BESS045	Battery Energy Storage System 045	232	13	208	11	850	8	820	8	486	10
BESS046	Battery Energy Storage System 046	235	14	211	12	850	8	820	8	488	12
BESS047	Battery Energy Storage System 047	250	16	226	13	853	8	823	8	500	16
BESS048	Battery Energy Storage System 048	253	16	229	13	854	8	823	8	502	16
BESS049	Battery Energy Storage System 049	233	13	209	11	858	8	828	8	491	8
BESS050	Battery Energy Storage System 050	236	14	212	12	858	8	828	8	494	10
BESS051	Battery Energy Storage System 051	251	16	227	13	861	8	831	8	505	15
BESS052	Battery Energy Storage System 052	254	16	230	13	862	8	831	8	507	16
BESS053	Battery Energy Storage System 053	234	13	211	11	866	8	836	8	497	7

Table E.1 Noise Impact Summary - Regular Operations

Source ID	Source Description	POR7		OPOR7		POR8		OPOR8		VL1	
		Distance (m)	Noise Level at POR (dBA)	Distance (m)	Noise Level at POR (dBA)	Distance (m)	Noise Level at POR (dBA)	Distance (m)	Noise Level at POR (dBA)	Distance (m)	Noise Level at POR (dBA)
BESS054	Battery Energy Storage System 054	237	14	214	12	866	8	836	8	499	9
BESS055	Battery Energy Storage System 055	252	16	229	13	869	8	839	8	510	15
BESS056	Battery Energy Storage System 056	255	16	231	13	870	8	839	8	512	15
BESS057	Battery Energy Storage System 057	235	13	213	11	874	8	844	8	502	7
BESS058	Battery Energy Storage System 058	238	14	216	12	874	8	844	8	504	9
BESS059	Battery Energy Storage System 059	253	16	230	13	877	8	847	8	515	15
BESS060	Battery Energy Storage System 060	256	16	233	13	877	8	847	9	518	15
BESS061	Battery Energy Storage System 061	237	10	215	9	882	8	851	8	507	7
BESS062	Battery Energy Storage System 062	240	14	218	12	882	8	852	8	510	9
BESS063	Battery Energy Storage System 063	254	16	232	13	885	8	855	8	521	14
BESS064	Battery Energy Storage System 064	257	16	235	13	885	8	855	9	523	15
BESS065	Battery Energy Storage System 065	239	10	218	9	889	7	859	8	513	7
BESS066	Battery Energy Storage System 066	241	14	221	12	890	8	860	8	515	9
BESS067	Battery Energy Storage System 067	256	16	235	13	893	7	862	8	526	14
BESS068	Battery Energy Storage System 068	259	16	237	13	893	8	863	8	528	15
BESS069	Battery Energy Storage System 069	241	10	221	9	897	7	867	8	519	7
BESS070	Battery Energy Storage System 070	243	14	223	12	898	7	868	8	521	9
BESS071	Battery Energy Storage System 071	258	16	237	13	901	7	870	8	532	14
BESS072	Battery Energy Storage System 072	261	16	240	13	901	8	871	8	534	14
BESS073	Battery Energy Storage System 073	243	10	224	9	905	7	875	8	524	7
BESS074	Battery Energy Storage System 074	246	14	226	12	906	7	876	8	526	9
BESS075	Battery Energy Storage System 075	260	15	240	13	908	7	878	8	537	14
BESS076	Battery Energy Storage System 076	263	16	243	13	909	8	879	8	539	14
BESS077	Battery Energy Storage System 077	245	10	227	9	913	7	883	8	530	7
BESS078	Battery Energy Storage System 078	248	14	229	12	914	7	884	8	532	9
BESS079	Battery Energy Storage System 079	262	15	243	13	916	7	886	8	543	14
BESS080	Battery Energy Storage System 080	265	16	246	13	917	8	887	8	545	14
BESS081	Battery Energy Storage System 081	248	10	230	9	921	7	891	8	536	7
BESS082	Battery Energy Storage System 082	251	14	233	11	922	7	892	8	538	9
BESS083	Battery Energy Storage System 083	265	15	246	13	924	7	894	8	548	14
BESS084	Battery Energy Storage System 084	268	16	249	13	925	7	895	8	550	14
BESS085	Battery Energy Storage System 085	269	8	242	8	826	6	795	6	496	9
BESS086	Battery Energy Storage System 086	272	10	245	9	826	6	796	6	498	12
BESS087	Battery Energy Storage System 087	287	13	260	11	830	6	799	6	510	12
BESS088	Battery Energy Storage System 088	290	13	263	11	831	6	800	6	513	12
BESS089	Battery Energy Storage System 089	268	8	242	8	833	8	803	8	500	9
BESS090	Battery Energy Storage System 090	271	10	245	9	834	8	804	8	503	12
BESS091	Battery Energy Storage System 091	286	13	260	11	838	8	807	8	515	14
BESS092	Battery Energy Storage System 092	289	13	263	11	838	8	808	9	517	14
BESS093	Battery Energy Storage System 093	268	8	243	8	841	8	811	8	505	6
BESS094	Battery Energy Storage System 094	271	10	246	9	842	8	812	8	507	9
BESS095	Battery Energy Storage System 095	286	12	260	11	845	8	815	9	519	14
BESS096	Battery Energy Storage System 096	289	13	263	11	846	8	816	9	522	14
BESS097	Battery Energy Storage System 097	268	8	243	8	849	8	819	8	510	6
BESS098	Battery Energy Storage System 098	271	10	246	9	850	8	819	8	512	9
BESS099	Battery Energy Storage System 099	286	12	261	11	853	8	823	8	524	14
BESS100	Battery Energy Storage System 100	289	13	264	11	854	8	823	8	527	14
BESS101	Battery Energy Storage System 101	269	8	244	8	857	8	827	8	515	6
BESS102	Battery Energy Storage System 102	272	10	247	9	858	8	827	8	517	9
BESS103	Battery Energy Storage System 103	287	12	262	11	861	8	831	8	529	13
BESS104	Battery Energy Storage System 104	290	13	265	11	862	8	831	8	531	14
BESS105	Battery Energy Storage System 105	269	8	245	8	865	8	835	8	520	6
BESS106	Battery Energy Storage System 106	272	10	248	9	866	8	835	8	522	9

Table E.1 Noise Impact Summary - Regular Operations

Source ID	Source Description	POR7		OPOR7		POR8		OPOR8		VL1	
		Distance (m)	Noise Level at POR (dBA)	Distance (m)	Noise Level at POR (dBA)	Distance (m)	Noise Level at POR (dBA)	Distance (m)	Noise Level at POR (dBA)	Distance (m)	Noise Level at POR (dBA)
BESS107	Battery Energy Storage System 107	287	12	263	10	869	8	838	8	534	13
BESS108	Battery Energy Storage System 108	290	13	266	11	870	8	839	8	536	13
BESS109	Battery Energy Storage System 109	270	8	247	8	873	8	842	8	525	6
BESS110	Battery Energy Storage System 110	273	10	250	9	873	8	843	8	527	9
BESS111	Battery Energy Storage System 111	288	12	264	10	877	8	846	8	539	13
BESS112	Battery Energy Storage System 112	291	13	267	10	877	8	847	8	541	13
BESS113	Battery Energy Storage System 113	271	8	248	8	881	8	850	8	530	6
BESS114	Battery Energy Storage System 114	274	10	251	9	881	8	851	8	532	9
BESS115	Battery Energy Storage System 115	289	13	266	10	885	8	854	8	543	13
BESS116	Battery Energy Storage System 116	292	13	269	10	885	8	855	8	546	13
BESS117	Battery Energy Storage System 117	273	8	250	8	888	7	858	8	535	6
BESS118	Battery Energy Storage System 118	275	10	253	9	889	8	859	8	537	9
BESS119	Battery Energy Storage System 119	290	12	268	10	892	7	862	8	549	13
BESS120	Battery Energy Storage System 120	293	13	270	10	893	7	863	8	551	13
BESS121	Battery Energy Storage System 121	274	8	252	8	896	7	866	8	540	5
BESS122	Battery Energy Storage System 122	277	10	255	9	897	7	867	8	542	9
BESS123	Battery Energy Storage System 123	292	13	270	10	900	7	870	8	554	13
BESS124	Battery Energy Storage System 124	294	13	272	10	901	7	870	8	556	13
BESS125	Battery Energy Storage System 125	276	8	255	8	904	7	874	7	545	5
BESS126	Battery Energy Storage System 126	279	10	258	9	905	7	875	8	548	8
BESS127	Battery Energy Storage System 127	293	12	272	10	908	7	878	8	559	13
BESS128	Battery Energy Storage System 128	296	13	275	10	909	7	878	8	561	13
BESS129	Battery Energy Storage System 129	278	8	257	7	912	7	882	7	551	5
BESS130	Battery Energy Storage System 130	281	10	260	9	913	7	882	8	553	8
BESS131	Battery Energy Storage System 131	295	12	274	10	916	7	886	8	564	13
BESS132	Battery Energy Storage System 132	298	13	277	10	917	7	886	8	566	13
BESS133	Battery Energy Storage System 133	280	8	260	7	920	7	890	7	556	5
BESS134	Battery Energy Storage System 134	283	10	263	9	921	7	890	8	558	8
BESS135	Battery Energy Storage System 135	297	12	277	10	924	7	893	8	569	12
BESS136	Battery Energy Storage System 136	300	13	280	10	924	7	894	8	572	12
BESS137	Battery Energy Storage System 137	283	8	263	7	928	7	898	7	562	5
BESS138	Battery Energy Storage System 138	285	10	266	9	929	7	898	7	564	8
BESS139	Battery Energy Storage System 139	299	12	280	10	932	7	901	7	575	12
BESS140	Battery Energy Storage System 140	302	13	283	10	932	7	902	7	577	12
BESS141	Battery Energy Storage System 141	334	13	304	13	720	13	689	14	473	9
BESS142	Battery Energy Storage System 142	336	17	306	17	721	13	690	14	476	12
BESS143	Battery Energy Storage System 143	350	19	320	19	726	13	695	14	490	17
BESS144	Battery Energy Storage System 144	353	18	323	19	727	13	696	14	493	20
BESS145	Battery Energy Storage System 145	331	13	301	13	728	11	697	11	476	10
BESS146	Battery Energy Storage System 146	333	14	303	16	729	13	698	10	479	11
BESS147	Battery Energy Storage System 147	347	16	317	16	733	13	703	14	493	15
BESS148	Battery Energy Storage System 148	350	17	320	17	734	13	704	10	496	16
BESS149	Battery Energy Storage System 149	327	9	298	9	735	9	705	10	479	10
BESS150	Battery Energy Storage System 150	330	14	300	13	736	10	706	10	482	12
BESS151	Battery Energy Storage System 151	344	15	314	15	741	9	710	12	496	15
BESS152	Battery Energy Storage System 152	347	16	317	15	742	13	711	10	498	16
BESS153	Battery Energy Storage System 153	325	9	295	9	743	9	712	9	482	10
BESS154	Battery Energy Storage System 154	328	13	298	12	743	9	713	10	485	11
BESS155	Battery Energy Storage System 155	342	15	312	13	748	9	717	10	498	15
BESS156	Battery Energy Storage System 156	344	15	315	13	749	12	718	10	501	16
BESS157	Battery Energy Storage System 157	322	9	293	8	750	9	720	9	485	10
BESS158	Battery Energy Storage System 158	325	13	295	11	751	9	720	10	488	12
BESS159	Battery Energy Storage System 159	339	15	310	13	756	9	725	9	501	15

Table E.1 Noise Impact Summary - Regular Operations

Source ID	Source Description	POR7		OPOR7		POR8		OPOR8		VL1	
		Distance (m)	Noise Level at POR (dBA)	Distance (m)	Noise Level at POR (dBA)	Distance (m)	Noise Level at POR (dBA)	Distance (m)	Noise Level at POR (dBA)	Distance (m)	Noise Level at POR (dBA)
BESS160	Battery Energy Storage System 160	342	15	312	13	757	10	726	10	504	16
BESS161	Battery Energy Storage System 161	320	8	290	8	758	8	727	9	488	10
BESS162	Battery Energy Storage System 162	322	13	293	11	759	9	728	9	491	12
BESS163	Battery Energy Storage System 163	337	14	307	12	763	10	733	10	505	15
BESS164	Battery Energy Storage System 164	339	15	310	13	764	10	734	10	507	16
BESS165	Battery Energy Storage System 165	317	8	288	8	766	8	735	9	492	10
BESS166	Battery Energy Storage System 166	320	12	291	11	767	9	736	9	494	12
BESS167	Battery Energy Storage System 167	334	14	305	12	771	9	740	10	508	15
BESS168	Battery Energy Storage System 168	337	15	308	13	772	9	741	10	510	16
BESS169	Battery Energy Storage System 169	315	8	286	7	773	8	743	9	495	10
BESS170	Battery Energy Storage System 170	318	12	289	11	774	9	743	9	498	12
BESS171	Battery Energy Storage System 171	332	14	304	12	779	9	748	10	511	15
BESS172	Battery Energy Storage System 172	335	14	306	12	780	9	749	10	514	16
BESS173	Battery Energy Storage System 173	313	8	284	7	781	8	750	9	499	10
BESS174	Battery Energy Storage System 174	316	12	287	11	782	9	751	9	501	12
BESS175	Battery Energy Storage System 175	331	14	302	12	786	9	756	9	515	15
BESS176	Battery Energy Storage System 176	333	14	305	12	787	9	756	9	517	16
BESS177	Battery Energy Storage System 177	311	8	283	7	789	8	758	8	502	10
BESS178	Battery Energy Storage System 178	314	12	286	11	790	8	759	9	505	12
BESS179	Battery Energy Storage System 179	329	14	300	12	794	9	763	9	518	15
BESS180	Battery Energy Storage System 180	332	14	303	12	795	9	764	9	521	16
BESS181	Battery Energy Storage System 181	310	9	282	8	797	8	766	8	506	10
BESS182	Battery Energy Storage System 182	313	13	285	11	797	8	767	9	509	12
BESS183	Battery Energy Storage System 183	327	15	299	12	802	9	771	9	522	15
BESS184	Battery Energy Storage System 184	330	15	302	12	803	9	772	9	524	16
BESS185	Battery Energy Storage System 185	308	12	281	11	804	8	774	8	510	10
BESS186	Battery Energy Storage System 186	311	16	283	14	805	8	774	9	513	12
BESS187	Battery Energy Storage System 187	326	18	298	15	809	9	779	9	526	16
BESS188	Battery Energy Storage System 188	329	19	301	16	810	9	780	9	528	16
BESS189	Battery Energy Storage System 189	370	13	340	12	733	13	702	14	510	12
BESS190	Battery Energy Storage System 190	384	15	354	14	738	13	707	13	524	17
BESS191	Battery Energy Storage System 191	387	15	357	15	739	13	708	13	527	19
BESS192	Battery Energy Storage System 192	365	8	335	8	739	10	708	10	510	9
BESS193	Battery Energy Storage System 193	367	13	338	11	740	13	709	14	513	11
BESS194	Battery Energy Storage System 194	381	14	352	13	746	13	715	13	527	15
BESS195	Battery Energy Storage System 195	384	15	354	13	747	13	716	9	530	15
BESS196	Battery Energy Storage System 196	362	8	332	7	747	9	716	9	513	7
BESS197	Battery Energy Storage System 197	365	12	335	11	748	10	717	10	516	9
BESS198	Battery Energy Storage System 198	379	14	349	12	753	9	722	9	530	15
BESS199	Battery Energy Storage System 199	381	15	352	12	754	13	723	9	532	15
BESS200	Battery Energy Storage System 200	359	8	330	7	754	8	723	9	516	7
BESS201	Battery Energy Storage System 201	362	12	333	10	755	9	725	9	518	9
BESS202	Battery Energy Storage System 202	376	14	347	12	761	9	730	9	532	15
BESS203	Battery Energy Storage System 203	379	14	350	12	762	9	731	10	535	15
BESS204	Battery Energy Storage System 204	357	8	327	7	762	8	731	9	519	7
BESS205	Battery Energy Storage System 205	360	12	330	10	763	9	732	9	521	9
BESS206	Battery Energy Storage System 206	374	14	345	12	768	9	737	9	535	15
BESS207	Battery Energy Storage System 207	377	14	347	12	769	9	738	10	538	15
BESS208	Battery Energy Storage System 208	354	8	325	7	770	8	739	8	522	7
BESS209	Battery Energy Storage System 209	357	12	328	10	771	9	740	9	524	9
BESS210	Battery Energy Storage System 210	372	13	343	11	776	9	745	9	538	15
BESS211	Battery Energy Storage System 211	374	14	345	12	777	9	746	10	541	15
BESS212	Battery Energy Storage System 212	352	7	323	7	777	8	746	8	525	7

Table E.1 Noise Impact Summary - Regular Operations

Source ID	Source Description	POR7		OPOR7		POR8		OPOR8		VL1	
		Distance (m)	Noise Level at POR (dBA)	Distance (m)	Noise Level at POR (dBA)	Distance (m)	Noise Level at POR (dBA)	Distance (m)	Noise Level at POR (dBA)	Distance (m)	Noise Level at POR (dBA)
BESS213	Battery Energy Storage System 213	355	12	326	10	778	9	747	9	527	9
BESS214	Battery Energy Storage System 214	370	13	341	11	783	9	752	9	541	14
BESS215	Battery Energy Storage System 215	372	14	344	12	784	9	753	10	544	15
BESS216	Battery Energy Storage System 216	350	7	322	6	785	8	754	8	528	7
BESS217	Battery Energy Storage System 217	353	12	325	10	786	9	755	9	531	9
BESS218	Battery Energy Storage System 218	368	13	339	11	791	9	760	9	544	14
BESS219	Battery Energy Storage System 219	371	14	342	11	792	9	761	9	547	15
BESS220	Battery Energy Storage System 220	349	7	320	6	792	8	761	8	531	7
BESS221	Battery Energy Storage System 221	352	12	323	10	793	9	762	9	534	9
BESS222	Battery Energy Storage System 222	366	13	338	11	798	9	767	9	548	14
BESS223	Battery Energy Storage System 223	369	14	341	11	799	9	768	9	550	15
BESS224	Battery Energy Storage System 224	347	7	319	6	800	8	769	8	535	7
BESS225	Battery Energy Storage System 225	350	12	322	10	801	9	770	9	538	9
BESS226	Battery Energy Storage System 226	365	13	336	11	806	9	775	9	551	14
BESS227	Battery Energy Storage System 227	367	14	339	11	807	9	776	9	554	15
BESS228	Battery Energy Storage System 228	346	7	318	7	808	8	777	8	538	7
BESS229	Battery Energy Storage System 229	349	12	321	10	808	9	778	9	541	9
BESS230	Battery Energy Storage System 230	363	13	335	11	813	9	783	9	554	14
BESS231	Battery Energy Storage System 231	366	14	338	11	814	9	784	9	557	15
BESS232	Battery Energy Storage System 232	344	8	317	7	815	8	784	8	542	7
BESS233	Battery Energy Storage System 233	347	12	320	10	816	8	785	9	545	9
BESS234	Battery Energy Storage System 234	362	14	334	11	821	9	790	9	558	14
BESS235	Battery Energy Storage System 235	365	14	337	11	822	9	791	9	561	15
BESS236	Battery Energy Storage System 236	343	7	316	7	823	8	792	8	546	7
BESS237	Battery Energy Storage System 237	346	12	319	10	824	8	793	9	548	9
BESS238	Battery Energy Storage System 238	361	14	334	11	829	8	798	9	562	14
BESS239	Battery Energy Storage System 239	364	14	337	12	830	8	799	9	564	15
BESS240	Battery Energy Storage System 240	343	8	315	9	830	8	800	8	550	7
BESS241	Battery Energy Storage System 241	346	13	318	12	831	8	801	9	552	9
BESS242	Battery Energy Storage System 242	360	16	333	13	836	8	805	9	565	14
BESS243	Battery Energy Storage System 243	363	16	336	13	837	8	806	9	568	15
BESS244	Battery Energy Storage System 244	401	6	372	6	745	13	715	13	542	16
BESS245	Battery Energy Storage System 245	404	8	375	8	747	13	716	13	545	11
BESS246	Battery Energy Storage System 246	418	12	389	10	753	13	722	13	559	13
BESS247	Battery Energy Storage System 247	421	12	392	10	754	13	723	13	562	13
BESS248	Battery Energy Storage System 248	399	6	369	5	753	9	722	9	545	5
BESS249	Battery Energy Storage System 249	402	8	372	7	754	13	723	9	547	11
BESS250	Battery Energy Storage System 250	416	11	386	9	760	13	729	13	562	13
BESS251	Battery Energy Storage System 251	418	12	389	10	761	13	730	9	564	13
BESS252	Battery Energy Storage System 252	396	6	367	5	760	8	729	8	547	5
BESS253	Battery Energy Storage System 253	399	8	370	7	761	10	730	10	550	8
BESS254	Battery Energy Storage System 254	413	11	384	9	767	9	736	9	564	13
BESS255	Battery Energy Storage System 255	416	12	387	9	769	13	738	9	567	13
BESS256	Battery Energy Storage System 256	394	6	365	5	768	8	737	8	550	5
BESS257	Battery Energy Storage System 257	397	8	367	7	769	9	738	9	553	8
BESS258	Battery Energy Storage System 258	411	11	382	9	775	9	744	9	567	13
BESS259	Battery Energy Storage System 259	414	11	385	9	776	9	745	9	569	13
BESS260	Battery Energy Storage System 260	392	6	363	5	775	8	744	8	553	4
BESS261	Battery Energy Storage System 261	395	8	365	7	776	9	745	9	555	8
BESS262	Battery Energy Storage System 262	409	11	380	9	782	9	751	9	569	12
BESS263	Battery Energy Storage System 263	412	11	383	9	783	9	752	9	572	13
BESS264	Battery Energy Storage System 264	390	5	361	5	783	8	752	8	555	4
BESS265	Battery Energy Storage System 265	392	7	364	7	784	9	753	9	558	8

Table E.1 Noise Impact Summary - Regular Operations

Source ID	Source Description	POR7		OPOR7		POR8		OPOR8		VL1	
		Distance (m)	Noise Level at POR (dBA)	Distance (m)	Noise Level at POR (dBA)	Distance (m)	Noise Level at POR (dBA)	Distance (m)	Noise Level at POR (dBA)	Distance (m)	Noise Level at POR (dBA)
BESS266	Battery Energy Storage System 266	407	11	378	9	790	9	759	9	572	12
BESS267	Battery Energy Storage System 267	410	11	381	9	791	9	760	9	575	13
BESS268	Battery Energy Storage System 268	388	5	359	5	790	8	759	8	558	4
BESS269	Battery Energy Storage System 269	391	7	362	6	791	9	760	9	561	8
BESS270	Battery Energy Storage System 270	405	11	376	9	797	9	766	9	575	12
BESS271	Battery Energy Storage System 271	408	11	379	9	798	9	767	9	578	13
BESS272	Battery Energy Storage System 272	386	5	357	5	798	8	767	8	561	4
BESS273	Battery Energy Storage System 273	389	7	360	6	799	9	768	9	564	8
BESS274	Battery Energy Storage System 274	403	11	375	9	804	9	773	9	578	12
BESS275	Battery Energy Storage System 275	406	11	378	9	805	9	775	9	581	13
BESS276	Battery Energy Storage System 276	384	6	356	5	805	8	774	8	565	4
BESS277	Battery Energy Storage System 277	387	8	359	6	806	8	775	9	567	8
BESS278	Battery Energy Storage System 278	402	11	374	9	812	8	781	9	581	12
BESS279	Battery Energy Storage System 279	405	11	376	9	813	8	782	9	584	13
BESS280	Battery Energy Storage System 280	383	6	355	5	812	8	782	8	568	4
BESS281	Battery Energy Storage System 281	386	8	358	6	814	8	783	9	571	8
BESS282	Battery Energy Storage System 282	400	11	372	9	819	8	788	9	584	12
BESS283	Battery Energy Storage System 283	403	11	375	9	820	8	789	9	587	12
BESS284	Battery Energy Storage System 284	382	6	354	5	820	8	789	8	571	4
BESS285	Battery Energy Storage System 285	385	8	357	7	821	8	790	9	574	8
BESS286	Battery Energy Storage System 286	399	11	371	9	827	8	796	9	587	12
BESS287	Battery Energy Storage System 287	402	11	374	9	828	8	797	9	590	13
BESS288	Battery Energy Storage System 288	381	6	353	5	828	7	797	8	575	5
BESS289	Battery Energy Storage System 289	383	8	356	6	829	8	798	9	577	8
BESS290	Battery Energy Storage System 290	398	11	371	8	834	8	803	9	591	12
BESS291	Battery Energy Storage System 291	401	11	374	9	835	8	804	9	593	13
BESS292	Battery Energy Storage System 292	380	6	352	5	835	7	804	8	578	5
BESS293	Battery Energy Storage System 293	383	8	355	6	836	8	805	9	581	8
BESS294	Battery Energy Storage System 294	397	11	370	8	842	8	811	9	594	12
BESS295	Battery Energy Storage System 295	400	11	373	9	843	8	812	9	597	13
BESS296	Battery Energy Storage System 296	379	6	352	5	843	6	812	6	582	5
BESS297	Battery Energy Storage System 297	382	7	355	6	844	8	813	8	584	8
BESS298	Battery Energy Storage System 298	397	10	370	8	849	8	818	8	598	12
BESS299	Battery Energy Storage System 299	400	11	373	8	850	8	819	8	600	13
BESS300	Battery Energy Storage System 300	378	6	351	5	850	6	819	6	585	5
BESS301	Battery Energy Storage System 301	381	7	354	6	851	8	820	8	588	8
BESS302	Battery Energy Storage System 302	396	10	369	8	857	8	826	8	601	12
BESS303	Battery Energy Storage System 303	399	11	372	8	858	8	827	8	604	13
BESS304	Battery Energy Storage System 304	232	13	206	12	826	6	796	6	471	10
BESS305	Battery Energy Storage System 305	235	14	209	12	827	6	796	6	473	12
BESS306	Battery Energy Storage System 306	250	16	224	14	830	6	799	6	485	17
BESS307	Battery Energy Storage System 307	253	16	227	14	830	6	800	6	488	18
HVT001	Main Power Transformer 001	346	28	322	25	897	17	867	18	588	23
HVT002	Main Power Transformer 002	350	28	327	25	923	17	893	18	604	23
MVS001	Medium Voltage Substation 001	207	16	184	15	854	5	824	5	472	8
MVS002	Medium Voltage Substation 002	208	16	186	14	861	8	832	8	477	13
MVS003	Medium Voltage Substation 003	210	16	188	14	869	8	840	8	483	13
MVS004	Medium Voltage Substation 004	211	15	191	14	877	8	848	8	489	13
MVS005	Medium Voltage Substation 005	213	15	193	14	885	9	856	9	494	13
MVS006	Medium Voltage Substation 006	216	15	196	14	893	9	864	9	500	13
MVS007	Medium Voltage Substation 007	218	15	200	14	901	9	872	9	506	13
MVS008	Medium Voltage Substation 008	221	15	203	14	909	9	880	9	512	13
MVS009	Medium Voltage Substation 009	224	15	207	14	917	8	888	8	518	12

Table E.1 Noise Impact Summary - Regular Operations

Source ID	Source Description	POR7		OPOR7		POR8		OPOR8		VL1	
		Distance (m)	Noise Level at POR (dBA)	Distance (m)	Noise Level at POR (dBA)	Distance (m)	Noise Level at POR (dBA)	Distance (m)	Noise Level at POR (dBA)	Distance (m)	Noise Level at POR (dBA)
MVS010	Medium Voltage Substation 010	242	15	217	14	836	9	806	9	484	14
MVS011	Medium Voltage Substation 011	242	15	217	14	844	8	814	8	489	14
MVS012	Medium Voltage Substation 012	243	15	218	14	852	8	822	8	494	14
MVS013	Medium Voltage Substation 013	243	15	220	14	860	8	829	9	499	15
MVS014	Medium Voltage Substation 014	244	15	221	14	868	8	837	9	505	14
MVS015	Medium Voltage Substation 015	246	15	223	13	875	8	845	9	510	13
MVS016	Medium Voltage Substation 016	247	15	225	13	883	8	853	9	515	13
MVS017	Medium Voltage Substation 017	249	14	228	13	891	8	861	8	521	13
MVS018	Medium Voltage Substation 018	251	14	230	13	899	8	869	8	526	13
MVS019	Medium Voltage Substation 019	253	14	233	13	907	8	877	9	532	13
MVS020	Medium Voltage Substation 020	255	14	236	13	915	8	885	9	537	12
MVS021	Medium Voltage Substation 021	258	14	240	13	923	7	893	8	543	12
MVS022	Medium Voltage Substation 022	243	15	216	14	828	5	798	5	479	11
MVS023	Medium Voltage Substation 023	280	14	253	13	828	4	797	5	504	11
MVS024	Medium Voltage Substation 024	279	14	253	13	835	9	805	9	509	13
MVS025	Medium Voltage Substation 025	279	14	253	12	843	8	813	8	513	13
MVS026	Medium Voltage Substation 026	279	14	254	12	851	8	821	9	518	12
MVS027	Medium Voltage Substation 027	279	14	255	12	859	8	828	9	523	12
MVS028	Medium Voltage Substation 028	280	14	256	12	867	8	836	9	528	12
MVS029	Medium Voltage Substation 029	281	14	257	12	875	9	844	9	533	12
MVS030	Medium Voltage Substation 030	282	14	259	12	882	9	852	9	538	13
MVS031	Medium Voltage Substation 031	283	14	260	12	890	9	860	9	543	13
MVS032	Medium Voltage Substation 032	284	14	263	12	898	9	868	9	548	13
MVS033	Medium Voltage Substation 033	286	14	265	12	906	9	876	9	553	12
MVS034	Medium Voltage Substation 034	288	14	267	12	914	8	884	9	558	12
MVS035	Medium Voltage Substation 035	290	14	270	12	922	8	891	9	564	11
MVS036	Medium Voltage Substation 036	292	12	273	11	930	7	900	7	569	11
MVS037	Medium Voltage Substation 037	343	17	313	18	723	12	693	13	483	17
MVS038	Medium Voltage Substation 038	340	14	310	14	731	12	700	13	486	15
MVS039	Medium Voltage Substation 039	337	13	307	13	739	11	708	12	489	14
MVS040	Medium Voltage Substation 040	335	13	305	12	746	10	715	10	491	14
MVS041	Medium Voltage Substation 041	332	13	302	12	753	10	723	10	495	14
MVS042	Medium Voltage Substation 042	329	12	300	12	761	10	730	10	498	14
MVS043	Medium Voltage Substation 043	327	12	298	12	769	10	738	10	501	14
MVS044	Medium Voltage Substation 044	325	12	296	11	776	10	746	10	504	14
MVS045	Medium Voltage Substation 045	323	12	295	11	784	9	753	10	508	14
MVS046	Medium Voltage Substation 046	322	12	293	12	792	9	761	10	512	13
MVS047	Medium Voltage Substation 047	320	13	292	12	800	9	769	9	515	13
MVS048	Medium Voltage Substation 048	319	16	291	14	807	9	777	9	519	14
MVS049	Medium Voltage Substation 049	377	13	347	13	735	12	705	12	517	17
MVS050	Medium Voltage Substation 050	374	12	345	12	743	12	712	12	520	14
MVS051	Medium Voltage Substation 051	372	12	342	11	750	11	720	11	523	13
MVS052	Medium Voltage Substation 052	369	12	340	11	758	9	727	10	525	13
MVS053	Medium Voltage Substation 053	367	12	337	11	766	10	735	10	528	13
MVS054	Medium Voltage Substation 054	364	12	335	11	773	9	742	10	531	13
MVS055	Medium Voltage Substation 055	362	12	334	10	781	10	750	10	534	13
MVS056	Medium Voltage Substation 056	361	11	332	10	788	9	757	10	538	13
MVS057	Medium Voltage Substation 057	359	11	330	10	796	9	765	10	541	13
MVS058	Medium Voltage Substation 058	357	12	329	11	803	9	772	10	544	13
MVS059	Medium Voltage Substation 059	356	12	328	11	811	9	780	9	548	13
MVS060	Medium Voltage Substation 060	355	13	327	11	819	9	788	9	551	12
MVS061	Medium Voltage Substation 061	354	13	326	11	826	9	795	9	555	12
MVS062	Medium Voltage Substation 062	353	13	326	13	834	9	803	9	559	12

Table E.1 Noise Impact Summary - Regular Operations

Source ID	Source Description	POR7		OPOR7		POR8		OPOR8		VL1	
		Distance (m)	Noise Level at POR (dBA)	Distance (m)	Noise Level at POR (dBA)	Distance (m)	Noise Level at POR (dBA)	Distance (m)	Noise Level at POR (dBA)	Distance (m)	Noise Level at POR (dBA)
MVS063	Medium Voltage Substation 063	411	11	382	10	750	12	719	12	552	15
MVS064	Medium Voltage Substation 064	409	11	379	10	757	12	726	12	554	13
MVS065	Medium Voltage Substation 065	406	11	377	10	764	11	733	11	557	12
MVS066	Medium Voltage Substation 066	404	11	375	9	772	9	741	10	560	12
MVS067	Medium Voltage Substation 067	402	10	373	9	779	10	748	10	562	11
MVS068	Medium Voltage Substation 068	400	10	371	9	787	9	756	10	565	11
MVS069	Medium Voltage Substation 069	398	10	369	9	794	9	763	10	568	11
MVS070	Medium Voltage Substation 070	396	10	368	9	801	9	771	10	571	11
MVS071	Medium Voltage Substation 071	395	10	366	9	809	9	778	10	574	11
MVS072	Medium Voltage Substation 072	393	11	365	10	816	9	785	9	577	11
MVS073	Medium Voltage Substation 073	392	12	364	10	824	9	793	9	581	11
MVS074	Medium Voltage Substation 074	391	12	363	10	831	9	800	9	584	11
MVS075	Medium Voltage Substation 075	390	12	363	10	839	9	808	9	587	11
MVS076	Medium Voltage Substation 076	389	11	362	10	846	8	815	9	591	10
MVS077	Medium Voltage Substation 077	389	11	362	10	854	8	823	9	595	10
HVAC001	HVAC001	342	29	321	27	945	22	914	22	609	28

Table E.2 Noise Impact Summary - Emergency Generator Testing

Source ID	Source Description	POR1		OPOR1		POR2		OPOR2		POR3		OPOR3	
		Distance (m)	Noise Level at POR (dBA)	Distance (m)	Noise Level at POR (dBA)	Distance (m)	Noise Level at POR (dBA)	Distance (m)	Noise Level at POR (dBA)	Distance (m)	Noise Level at POR (dBA)	Distance (m)	Noise Level at POR (dBA)
Gen001	Emergency Generator	1465	17	1448	18	562	29	532	28	547	29	518	29

Table E.2 Noise Impact Summary - Emergency Generator Testing

Source ID	Source Description	POR4		OPOR4		POR5		OPOR5		POR6		OPOR6	
		Distance (m)	Noise Level at POR (dBA)	Distance (m)	Noise Level at POR (dBA)	Distance (m)	Noise Level at POR (dBA)	Distance (m)	Noise Level at POR (dBA)	Distance (m)	Noise Level at POR (dBA)	Distance (m)	Noise Level at POR (dBA)
Gen001	Emergency Generator	547	30	518	30	673	26	648	26	1521	16	1491	17

Table E.2 Noise Impact Summary - Emergency Generator Testing

Source ID	Source Description	POR7		OPOR7		POR8		OPOR8		VL1	
		Distance (m)	Noise Level at POR (dBA)	Distance (m)	Noise Level at POR (dBA)	Distance (m)	Noise Level at POR (dBA)	Distance (m)	Noise Level at POR (dBA)	Distance (m)	Noise Level at POR (dBA)
Gen001	Emergency Generator	325	31	305	27	940	22	910	23	596	28

Appendix F Acoustic Model Sample Calculations



Sample Calculation at POR3 - Regular Operations

Receiver

Name: 3 Storey Residence - 2655 Marchurst Road
 ID: POR3
 X: 340566.18 m
 Y: 5029065.76 m
 Z: 103.12 m

Point Source, ISO 9613, Name: "HVAC001", ID: "!03!HVAC001"

Nr.	X	Y	Z	Refl.	DEN	Freq.	Lw	l/a	Optime	K0	Di	Adiv	Aatm	Agr	Afol	Ahous	Abar	Cmet	RL	Lr
	(m)	(m)	(m)			(Hz)	dB(A)	dB	dB	(dB)	(dB)	(dB)	(dB)	(dB)	(dB)	(dB)	(dB)	(dB)	(dB)	dB(A)
4	340616.65	5028506.47	107.00	0	DEN	A	94.9	0.0	0.0	0.0	0.0	66.0	1.7	-1.7	0.0	0.0	4.8	0.0	0.0	24.2

Point Source, ISO 9613, Name: "Main Power Transformer 001", ID: "!01!HVT001"

Nr.	X	Y	Z	Refl.	DEN	Freq.	Lw	l/a	Optime	K0	Di	Adiv	Aatm	Agr	Afol	Ahous	Abar	Cmet	RL	Lr
	(m)	(m)	(m)			(Hz)	dB(A)	dB	dB	(dB)	(dB)	(dB)	(dB)	(dB)	(dB)	(dB)	(dB)	(dB)	(dB)	dB(A)
17	340563.28	5028520.58	105.00	0	DEN	A	94.1	0.0	0.0	0.0	0.0	65.7	1.5	-1.7	0.0	0.0	4.8	0.0	0.0	23.8

Point Source, ISO 9613, Name: "Main Power Transformer 002", ID: "!01!HVT002"

Nr.	X	Y	Z	Refl.	DEN	Freq.	Lw	l/a	Optime	K0	Di	Adiv	Aatm	Agr	Afol	Ahous	Abar	Cmet	RL	Lr
	(m)	(m)	(m)			(Hz)	dB(A)	dB	dB	(dB)	(dB)	(dB)	(dB)	(dB)	(dB)	(dB)	(dB)	(dB)	(dB)	dB(A)
71	340586.98	5028507.30	105.00	0	DEN	A	94.1	0.0	0.0	0.0	0.0	65.9	1.6	-1.8	0.0	0.0	4.8	0.0	0.0	23.6

Point Source, ISO 9613, Name: "Battery Energy Storage System 001", ID: "!0000!BESS001"

Nr.	X	Y	Z	Refl.	DEN	Freq.	Lw	l/a	Optime	K0	Di	Adiv	Aatm	Agr	Afol	Ahous	Abar	Cmet	RL	Lr
	(m)	(m)	(m)			(Hz)	dB(A)	dB	dB	(dB)	(dB)	(dB)	(dB)	(dB)	(dB)	(dB)	(dB)	(dB)	(dB)	dB(A)
103	340624.35	5028656.19	103.95	0	DEN	A	84.4	0.0	0.0	0.0	0.0	63.3	1.9	-1.0	0.0	0.0	13.2	0.0	0.0	6.9

Point Source, ISO 9613, Name: "Battery Energy Storage System 002", ID: "!0000!BESS002"

Nr.	X	Y	Z	Refl.	DEN	Freq.	Lw	l/a	Optime	K0	Di	Adiv	Aatm	Agr	Afol	Ahous	Abar	Cmet	RL	Lr
	(m)	(m)	(m)			(Hz)	dB(A)	dB	dB	(dB)	(dB)	(dB)	(dB)	(dB)	(dB)	(dB)	(dB)	(dB)	(dB)	dB(A)
192	340622.90	5028653.64	103.95	0	DEN	A	84.4	0.0	0.0	0.0	0.0	63.4	1.9	-1.0	0.0	0.0	10.3	0.0	0.0	9.8

Point Source, ISO 9613, Name: "Medium Voltage Substation 001", ID: "!02!MVT001"

Nr.	X	Y	Z	Refl.	DEN	Freq.	Lw	l/a	Optime	K0	Di	Adiv	Aatm	Agr	Afol	Ahous	Abar	Cmet	RL	Lr
	(m)	(m)	(m)			(Hz)	dB(A)	dB	dB	(dB)	(dB)	(dB)	(dB)	(dB)	(dB)	(dB)	(dB)	(dB)	(dB)	dB(A)
267	340619.23	5028647.16	103.20	0	DEN	A	84.5	0.0	0.0	0.0	0.0	63.5	1.4	-0.5	0.0	0.0	11.0	0.0	0.0	9.1

Point Source, ISO 9613, Name: "Battery Energy Storage System 005", ID: "!0000!BESS005"

Nr.	X	Y	Z	Refl.	DEN	Freq.	Lw	l/a	Optime	K0	Di	Adiv	Aatm	Agr	Afol	Ahous	Abar	Cmet	RL	Lr
	(m)	(m)	(m)			(Hz)	dB(A)	dB	dB	(dB)	(dB)	(dB)	(dB)	(dB)	(dB)	(dB)	(dB)	(dB)	(dB)	dB(A)
348	340631.36	5028652.22	103.95	0	DEN	A	84.4	0.0	0.0	0.0	0.0	63.4	1.9	-1.0	0.0	0.0	13.2	0.0	0.0	6.8
356	340631.36	5028652.22	103.95	2	DEN	A	84.4	0.0	0.0	0.0	0.0	64.6	2.1	-1.7	0.0	0.0	4.9	0.0	14.4	0.1

Point Source, ISO 9613, Name: "Battery Energy Storage System 006", ID: "!0000!BESS006"

Nr.	X	Y	Z	Refl.	DEN	Freq.	Lw	l/a	Optime	K0	Di	Adiv	Aatm	Agr	Afol	Ahous	Abar	Cmet	RL	Lr
	(m)	(m)	(m)			(Hz)	dB(A)	dB	dB	(dB)	(dB)	(dB)	(dB)	(dB)	(dB)	(dB)	(dB)	(dB)	(dB)	dB(A)
421	340629.91	5028649.66	103.95	0	DEN	A	84.4	0.0	0.0	0.0	0.0	63.5	1.9	-1.1	0.0	0.0	10.3	0.0	0.0	9.8
450	340629.91	5028649.66	103.95	2	DEN	A	84.4	0.0	0.0	0.0	0.0	64.6	2.1	-1.7	0.0	0.0	4.9	0.0	14.4	0.1

Point Source, ISO 9613, Name: "Medium Voltage Substation 002", ID: "!02!MVT002"

Nr.	X	Y	Z	Refl.	DEN	Freq.	Lw	l/a	Optime	K0	Di	Adiv	Aatm	Agr	Afol	Ahous	Abar	Cmet	RL	Lr
	(m)	(m)	(m)			(Hz)	dB(A)	dB	dB	(dB)	(dB)	(dB)	(dB)	(dB)	(dB)	(dB)	(dB)	(dB)	(dB)	dB(A)
497	340626.24	5028643.19	103.20	0	DEN	A	84.5	0.0	0.0	0.0	0.0	63.6	1.4	-0.9	0.0	0.0	8.1	0.0	0.0	12.2
509	340626.24	5028643.19	103.20	1	DEN	A	84.5	0.0	0.0	0.0	0.0	64.3	1.5	-1.3	0.0	0.0	5.7	0.0	8.1	6.2

Point Source, ISO 9613, Name: "Battery Energy Storage System 009", ID: "!0000!BESS009"

Nr.	X	Y	Z	Refl.	DEN	Freq.	Lw	l/a	Optime	K0	Di	Adiv	Aatm	Agr	Afol	Ahous	Abar	Cmet	RL	Lr
	(m)	(m)	(m)			(Hz)	dB(A)	dB	dB	(dB)	(dB)	(dB)	(dB)	(dB)	(dB)	(dB)	(dB)	(dB)	(dB)	dB(A)
589	340638.37	5028648.24	103.95	0	DEN	A	84.4	0.0	0.0	0.0	0.0	63.5	1.9	-1.0	0.0	0.0	13.2	0.0	0.0	6.8
597	340638.37	5028648.24	103.95	1	DEN	A	84.4	0.0	0.0	0.0	0.0	64.6	2.1	-1.7	0.0	0.0	4.8	0.0	12.2	2.4
598	340638.37	5028648.24	103.95	2	DEN	A	84.4	0.0	0.0	0.0	0.0	64.7	2.1	-1.7	0.0	0.0	4.8	0.0	14.3	0.3

Sample Calculation at POR3 - Regular Operations

Point Source, ISO 9613, Name: "Battery Energy Storage System 304", ID: "I0002!BESS304"																				
Nr.	X	Y	Z	Refl.	DEN	Freq.	Lw	l/a	Optime	K0	Di	Adiv	Aatm	Agr	Afol	Ahous	Abar	Cmet	RL	Lr
	(m)	(m)	(m)			(Hz)	dB(A)	dB	dB	(dB)	(dB)	(dB)	(dB)	(dB)	(dB)	(dB)	(dB)	(dB)	(dB)	dB(A)
647	340578.36	5028640.29	103.95	0	DEN	A	84.4	0.0	0.0	0.0	0.0	63.6	1.9	-1.2	0.0	0.0	9.9	0.0	0.0	10.2

Point Source, ISO 9613, Name: "Battery Energy Storage System 010", ID: "I0000!BESS010"																				
Nr.	X	Y	Z	Refl.	DEN	Freq.	Lw	l/a	Optime	K0	Di	Adiv	Aatm	Agr	Afol	Ahous	Abar	Cmet	RL	Lr
	(m)	(m)	(m)			(Hz)	dB(A)	dB	dB	(dB)	(dB)	(dB)	(dB)	(dB)	(dB)	(dB)	(dB)	(dB)	(dB)	dB(A)
700	340636.92	5028645.69	103.95	0	DEN	A	84.4	0.0	0.0	0.0	0.0	63.6	1.9	-1.1	0.0	0.0	10.3	0.0	0.0	9.7
709	340636.92	5028645.69	103.95	1	DEN	A	84.4	0.0	0.0	0.0	0.0	64.5	2.1	-1.7	0.0	0.0	4.8	0.0	12.2	2.5

Point Source, ISO 9613, Name: "Battery Energy Storage System 003", ID: "I0001!BESS003"																				
Nr.	X	Y	Z	Refl.	DEN	Freq.	Lw	l/a	Optime	K0	Di	Adiv	Aatm	Agr	Afol	Ahous	Abar	Cmet	RL	Lr
	(m)	(m)	(m)			(Hz)	dB(A)	dB	dB	(dB)	(dB)	(dB)	(dB)	(dB)	(dB)	(dB)	(dB)	(dB)	(dB)	dB(A)
819	340615.56	5028640.69	103.95	0	DEN	A	84.4	0.0	0.0	0.0	0.0	63.6	1.9	-1.0	0.0	0.0	9.6	0.0	0.0	10.2
831	340615.56	5028640.69	103.95	1	DEN	A	84.4	0.0	0.0	0.0	0.0	64.1	2.0	-1.4	0.0	0.0	4.8	0.0	3.6	11.3

Point Source, ISO 9613, Name: "Medium Voltage Substation 003", ID: "I02!MVT003"																				
Nr.	X	Y	Z	Refl.	DEN	Freq.	Lw	l/a	Optime	K0	Di	Adiv	Aatm	Agr	Afol	Ahous	Abar	Cmet	RL	Lr
	(m)	(m)	(m)			(Hz)	dB(A)	dB	dB	(dB)	(dB)	(dB)	(dB)	(dB)	(dB)	(dB)	(dB)	(dB)	(dB)	dB(A)
884	340633.25	5028639.22	103.20	0	DEN	A	84.5	0.0	0.0	0.0	0.0	63.7	1.4	-0.9	0.0	0.0	8.1	0.0	0.0	12.2
897	340633.25	5028639.22	103.20	1	DEN	A	84.5	0.0	0.0	0.0	0.0	64.4	1.5	-1.3	0.0	0.0	5.8	0.0	8.1	6.0

Point Source, ISO 9613, Name: "Battery Energy Storage System 305", ID: "I0002!BESS305"																				
Nr.	X	Y	Z	Refl.	DEN	Freq.	Lw	l/a	Optime	K0	Di	Adiv	Aatm	Agr	Afol	Ahous	Abar	Cmet	RL	Lr
	(m)	(m)	(m)			(Hz)	dB(A)	dB	dB	(dB)	(dB)	(dB)	(dB)	(dB)	(dB)	(dB)	(dB)	(dB)	(dB)	dB(A)
979	340576.91	5028637.73	103.95	0	DEN	A	84.4	0.0	0.0	0.0	0.0	63.6	1.9	-1.2	0.0	0.0	7.6	0.0	0.0	12.5

Point Source, ISO 9613, Name: "Battery Energy Storage System 013", ID: "I0000!BESS013"																				
Nr.	X	Y	Z	Refl.	DEN	Freq.	Lw	l/a	Optime	K0	Di	Adiv	Aatm	Agr	Afol	Ahous	Abar	Cmet	RL	Lr
	(m)	(m)	(m)			(Hz)	dB(A)	dB	dB	(dB)	(dB)	(dB)	(dB)	(dB)	(dB)	(dB)	(dB)	(dB)	(dB)	dB(A)
1078	340645.38	5028644.27	103.95	0	DEN	A	84.4	0.0	0.0	0.0	0.0	63.6	1.9	-1.0	0.0	0.0	13.2	0.0	0.0	6.6
1088	340645.38	5028644.27	103.95	1	DEN	A	84.4	0.0	0.0	0.0	0.0	64.6	2.1	-1.7	0.0	0.0	4.8	0.0	12.2	2.3
1089	340645.38	5028644.27	103.95	2	DEN	A	84.4	0.0	0.0	0.0	0.0	64.7	2.2	-1.7	0.0	0.0	4.8	0.0	14.3	0.2

Point Source, ISO 9613, Name: "Battery Energy Storage System 037", ID: "I0002!BESS037"																				
Nr.	X	Y	Z	Refl.	DEN	Freq.	Lw	l/a	Optime	K0	Di	Adiv	Aatm	Agr	Afol	Ahous	Abar	Cmet	RL	Lr
	(m)	(m)	(m)			(Hz)	dB(A)	dB	dB	(dB)	(dB)	(dB)	(dB)	(dB)	(dB)	(dB)	(dB)	(dB)	(dB)	dB(A)
1193	340585.37	5028636.46	103.95	0	DEN	A	84.4	0.0	0.0	0.0	0.0	63.7	2.0	-1.2	0.0	0.0	10.0	0.0	0.0	10.0
1196	340585.37	5028636.46	103.95	1	DEN	A	84.4	0.0	0.0	0.0	0.0	64.8	2.2	-1.8	0.0	0.0	0.0	0.0	12.3	7.0

Point Source, ISO 9613, Name: "Battery Energy Storage System 004", ID: "I0001!BESS004"																				
Nr.	X	Y	Z	Refl.	DEN	Freq.	Lw	l/a	Optime	K0	Di	Adiv	Aatm	Agr	Afol	Ahous	Abar	Cmet	RL	Lr
	(m)	(m)	(m)			(Hz)	dB(A)	dB	dB	(dB)	(dB)	(dB)	(dB)	(dB)	(dB)	(dB)	(dB)	(dB)	(dB)	dB(A)
1292	340614.11	5028638.14	103.95	0	DEN	A	84.4	0.0	0.0	0.0	0.0	63.7	2.0	-1.0	0.0	0.0	9.6	0.0	0.0	10.2
1301	340614.11	5028638.14	103.95	1	DEN	A	84.4	0.0	0.0	0.0	0.0	64.1	2.0	-1.4	0.0	0.0	4.8	0.0	2.6	12.4

Point Source, ISO 9613, Name: "Medium Voltage Substation 022", ID: "I02!MVT022"																				
Nr.	X	Y	Z	Refl.	DEN	Freq.	Lw	l/a	Optime	K0	Di	Adiv	Aatm	Agr	Afol	Ahous	Abar	Cmet	RL	Lr
	(m)	(m)	(m)			(Hz)	dB(A)	dB	dB	(dB)	(dB)	(dB)	(dB)	(dB)	(dB)	(dB)	(dB)	(dB)	(dB)	dB(A)
1407	340573.24	5028631.26	103.20	0	DEN	A	84.5	0.0	0.0	0.0	0.0	63.8	1.4	-1.2	0.0	0.0	7.8	0.0	0.0	12.7
1422	340573.24	5028631.26	103.20	1	DEN	A	84.5	0.0	0.0	0.0	0.0	64.5	1.5	-1.3	0.0	0.0	7.3	0.0	9.3	3.2

Point Source, ISO 9613, Name: "Battery Energy Storage System 014", ID: "I0000!BESS014"																				
Nr.	X	Y	Z	Refl.	DEN	Freq.	Lw	l/a	Optime	K0	Di	Adiv	Aatm	Agr	Afol	Ahous	Abar	Cmet	RL	Lr
	(m)	(m)	(m)			(Hz)	dB(A)	dB	dB	(dB)	(dB)	(dB)	(dB)	(dB)	(dB)	(dB)	(dB)	(dB)	(dB)	dB(A)
1534	340643.93	5028641.71	103.95	0	DEN	A	84.4	0.0	0.0	0.0	0.0	63.7	2.0	-1.1	0.0	0.0	10.3	0.0	0.0	9.6
1543	340643.93	5028641.71	103.95	1	DEN	A	84.4	0.0	0.0	0.0	0.0	64.6	2.1	-1.7	0.0	0.0	4.8	0.0	12.3	2.3
1546	340643.93	5028641.71	103.95	2	DEN	A	84.4	0.0	0.0	0.0	0.0	64.8	2.2	-1.8	0.0	0.0	4.8	0.0	14.3	0.1

Point Source, ISO 9613, Name: "Battery Energy Storage System 038", ID: "I0002!BESS038"																				
Nr.	X	Y	Z	Refl.	DEN	Freq.	Lw	l/a	Optime	K0	Di	Adiv	Aatm	Agr	Afol	Ahous	Abar	Cmet	RL	Lr
	(m)	(m)	(m)			(Hz)	dB(A)	dB	dB	(dB)	(dB)	(dB)	(dB)	(dB)	(dB)	(dB)	(dB)	(dB)	(dB)	dB(A)
1652	340583.92	5028633.90	103.95	0	DEN	A	84.4	0.0	0.0	0.0	0.0	63.7	2.0	-1.2	0.0	0.0	7.6	0.0	0.0	12.4
1656	340583.92	5028633.90	103.95	1	DEN	A	84.4	0.0	0.0	0.0	0.0	64.7	2.1	-1.7	0.0	0.0	0.0	0.0	12.3	7.0

Sample Calculation at POR3 - Regular Operations

Point Source, ISO 9613, Name: "Battery Energy Storage System 007", ID: "I0001!BESS007"																				
Nr.	X	Y	Z	Refl.	DEN	Freq.	Lw	l/a	Optime	K0	Di	Adiv	Aatm	Agr	Afol	Ahous	Abar	Cmet	RL	Lr
	(m)	(m)	(m)			(Hz)	dB(A)	dB	dB	(dB)	(dB)	(dB)	(dB)	(dB)	(dB)	(dB)	(dB)	(dB)	(dB)	dB(A)
1742	340622.57	5028636.72	103.95	0	DEN	A	84.4	0.0	0.0	0.0	0.0	63.7	2.0	-1.2	0.0	0.0	5.9	0.0	0.0	14.0
1755	340622.57	5028636.72	103.95	1	DEN	A	84.4	0.0	0.0	0.0	0.0	64.2	2.1	-1.4	0.0	0.0	4.8	0.0	3.6	11.2

Point Source, ISO 9613, Name: "Medium Voltage Substation 004", ID: "I02!MVT004"																				
Nr.	X	Y	Z	Refl.	DEN	Freq.	Lw	l/a	Optime	K0	Di	Adiv	Aatm	Agr	Afol	Ahous	Abar	Cmet	RL	Lr
	(m)	(m)	(m)			(Hz)	dB(A)	dB	dB	(dB)	(dB)	(dB)	(dB)	(dB)	(dB)	(dB)	(dB)	(dB)	(dB)	dB(A)
1847	340640.26	5028635.24	103.20	0	DEN	A	84.5	0.0	0.0	0.0	0.0	63.8	1.4	-1.0	0.0	0.0	8.1	0.0	0.0	12.2
1858	340640.26	5028635.24	103.20	1	DEN	A	84.5	0.0	0.0	0.0	0.0	64.5	1.5	-1.4	0.0	0.0	6.4	0.0	8.8	4.7

Point Source, ISO 9613, Name: "Battery Energy Storage System 041", ID: "I0002!BESS041"																				
Nr.	X	Y	Z	Refl.	DEN	Freq.	Lw	l/a	Optime	K0	Di	Adiv	Aatm	Agr	Afol	Ahous	Abar	Cmet	RL	Lr
	(m)	(m)	(m)			(Hz)	dB(A)	dB	dB	(dB)	(dB)	(dB)	(dB)	(dB)	(dB)	(dB)	(dB)	(dB)	(dB)	dB(A)
1951	340592.38	5028632.48	103.95	0	DEN	A	84.4	0.0	0.0	0.0	0.0	63.8	2.0	-1.2	0.0	0.0	10.0	0.0	0.0	9.9
1955	340592.38	5028632.48	103.95	1	DEN	A	84.4	0.0	0.0	0.0	0.0	64.8	2.2	-1.8	0.0	0.0	0.0	0.0	12.3	6.9

Point Source, ISO 9613, Name: "Battery Energy Storage System 017", ID: "I0000!BESS017"																				
Nr.	X	Y	Z	Refl.	DEN	Freq.	Lw	l/a	Optime	K0	Di	Adiv	Aatm	Agr	Afol	Ahous	Abar	Cmet	RL	Lr
	(m)	(m)	(m)			(Hz)	dB(A)	dB	dB	(dB)	(dB)	(dB)	(dB)	(dB)	(dB)	(dB)	(dB)	(dB)	(dB)	dB(A)
2029	340652.39	5028640.29	103.95	0	DEN	A	84.4	0.0	0.0	0.0	0.0	63.8	2.0	-1.0	0.0	0.0	13.2	0.0	0.0	6.5
2034	340652.39	5028640.29	103.95	1	DEN	A	84.4	0.0	0.0	0.0	0.0	64.7	2.2	-1.7	0.0	0.0	4.8	0.0	12.3	2.2

Point Source, ISO 9613, Name: "Medium Voltage Substation 010", ID: "I02!MVT010"																				
Nr.	X	Y	Z	Refl.	DEN	Freq.	Lw	l/a	Optime	K0	Di	Adiv	Aatm	Agr	Afol	Ahous	Abar	Cmet	RL	Lr
	(m)	(m)	(m)			(Hz)	dB(A)	dB	dB	(dB)	(dB)	(dB)	(dB)	(dB)	(dB)	(dB)	(dB)	(dB)	(dB)	dB(A)
2281	340580.25	5028627.43	103.20	0	DEN	A	84.5	0.0	0.0	0.0	0.0	63.8	1.4	-1.2	0.0	0.0	6.3	0.0	0.0	14.2
2292	340580.25	5028627.43	103.20	1	DEN	A	84.5	0.0	0.0	0.0	0.0	64.6	1.5	-1.4	0.0	0.0	4.8	0.0	7.2	7.7

Point Source, ISO 9613, Name: "Battery Energy Storage System 008", ID: "I0001!BESS008"																				
Nr.	X	Y	Z	Refl.	DEN	Freq.	Lw	l/a	Optime	K0	Di	Adiv	Aatm	Agr	Afol	Ahous	Abar	Cmet	RL	Lr
	(m)	(m)	(m)			(Hz)	dB(A)	dB	dB	(dB)	(dB)	(dB)	(dB)	(dB)	(dB)	(dB)	(dB)	(dB)	(dB)	dB(A)
2342	340621.12	5028634.16	103.95	0	DEN	A	84.4	0.0	0.0	0.0	0.0	63.8	2.0	-1.2	0.0	0.0	5.9	0.0	0.0	14.0
2345	340621.12	5028634.16	103.95	1	DEN	A	84.4	0.0	0.0	0.0	0.0	64.2	2.0	-1.4	0.0	0.0	4.8	0.0	2.6	12.3

Point Source, ISO 9613, Name: "Battery Energy Storage System 018", ID: "I0000!BESS018"																				
Nr.	X	Y	Z	Refl.	DEN	Freq.	Lw	l/a	Optime	K0	Di	Adiv	Aatm	Agr	Afol	Ahous	Abar	Cmet	RL	Lr
	(m)	(m)	(m)			(Hz)	dB(A)	dB	dB	(dB)	(dB)	(dB)	(dB)	(dB)	(dB)	(dB)	(dB)	(dB)	(dB)	dB(A)
2375	340650.94	5028637.74	103.95	0	DEN	A	84.4	0.0	0.0	0.0	0.0	63.8	2.0	-1.1	0.0	0.0	10.3	0.0	0.0	9.5
2377	340650.94	5028637.74	103.95	1	DEN	A	84.4	0.0	0.0	0.0	0.0	64.7	2.1	-1.7	0.0	0.0	4.8	0.0	12.3	2.2

Point Source, ISO 9613, Name: "Battery Energy Storage System 042", ID: "I0002!BESS042"																				
Nr.	X	Y	Z	Refl.	DEN	Freq.	Lw	l/a	Optime	K0	Di	Adiv	Aatm	Agr	Afol	Ahous	Abar	Cmet	RL	Lr
	(m)	(m)	(m)			(Hz)	dB(A)	dB	dB	(dB)	(dB)	(dB)	(dB)	(dB)	(dB)	(dB)	(dB)	(dB)	(dB)	dB(A)
2406	340590.93	5028629.93	103.95	0	DEN	A	84.4	0.0	0.0	0.0	0.0	63.8	2.0	-1.2	0.0	0.0	7.5	0.0	0.0	12.3
2407	340590.93	5028629.93	103.95	1	DEN	A	84.4	0.0	0.0	0.0	0.0	64.8	2.2	-1.7	0.0	0.0	0.0	0.0	12.3	6.9

Point Source, ISO 9613, Name: "Battery Energy Storage System 011", ID: "I0001!BESS011"																				
Nr.	X	Y	Z	Refl.	DEN	Freq.	Lw	l/a	Optime	K0	Di	Adiv	Aatm	Agr	Afol	Ahous	Abar	Cmet	RL	Lr
	(m)	(m)	(m)			(Hz)	dB(A)	dB	dB	(dB)	(dB)	(dB)	(dB)	(dB)	(dB)	(dB)	(dB)	(dB)	(dB)	dB(A)
2442	340629.58	5028632.75	103.95	0	DEN	A	84.4	0.0	0.0	0.0	0.0	63.8	2.0	-1.3	0.0	0.0	5.5	0.0	0.0	14.5
2452	340629.58	5028632.75	103.95	1	DEN	A	84.4	0.0	0.0	0.0	0.0	64.3	2.1	-1.5	0.0	0.0	4.9	0.0	3.7	10.9

Point Source, ISO 9613, Name: "Medium Voltage Substation 005", ID: "I02!MVT005"																				
Nr.	X	Y	Z	Refl.	DEN	Freq.	Lw	l/a	Optime	K0	Di	Adiv	Aatm	Agr	Afol	Ahous	Abar	Cmet	RL	Lr
	(m)	(m)	(m)			(Hz)	dB(A)	dB	dB	(dB)	(dB)	(dB)	(dB)	(dB)	(dB)	(dB)	(dB)	(dB)	(dB)	dB(A)
2489	340647.27	5028631.27	103.20	0	DEN	A	84.5	0.0	0.0	0.0	0.0	63.9	1.4	-1.0	0.0	0.0	8.1	0.0	0.0	12.1
2493	340647.27	5028631.27	103.20	1	DEN	A	84.5	0.0	0.0	0.0	0.0	64.6	1.5	-1.5	0.0	0.0	6.3	0.0	8.7	4.9
2523	340647.27	5028631.27	103.20	1	DEN	A	84.5	0.0	0.0	0.0	0.0	64.1	1.4	-1.3	0.0	0.0	5.8	0.0	7.1	7.4

Point Source, ISO 9613, Name: "Battery Energy Storage System 045", ID: "I0002!BESS045"																				
Nr.	X	Y	Z	Refl.	DEN	Freq.	Lw	l/a	Optime	K0	Di	Adiv	Aatm	Agr	Afol	Ahous	Abar	Cmet	RL	Lr
	(m)	(m)	(m)			(Hz)	dB(A)	dB	dB	(dB)	(dB)	(dB)	(dB)	(dB)	(dB)	(dB)	(dB)	(dB)	(dB)	dB(A)
2534	340599.39	5028628.51	103.95	0	DEN	A	84.4	0.0	0.0	0.0	0.0	63.8	2.0	-1.2	0.0	0.0	13.5	0.0	0.0	6.3
2535	340599.39	5028628.51	103.95	1	DEN	A	84.4	0.0	0.0	0.0	0.0	64.9	2.2	-1.8	0.0	0.0	4.8	0.0	12.3	2.0

Sample Calculation at POR3 - Regular Operations

Point Source, ISO 9613, Name: "Medium Voltage Substation 011", ID: "I02!MVT011"																				
Nr.	X	Y	Z	Refl.	DEN	Freq.	Lw	l/a	Optime	K0	Di	Adiv	Aatm	Agr	Afol	Ahous	Abar	Cmet	RL	Lr
	(m)	(m)	(m)			(Hz)	dB(A)	dB	dB	(dB)	(dB)	(dB)	(dB)	(dB)	(dB)	(dB)	(dB)	(dB)	(dB)	dB(A)
2572	340587.26	5028623.46	103.20	0	DEN	A	84.5	0.0	0.0	0.0	0.0	63.9	1.4	-1.3	0.0	0.0	6.2	0.0	0.0	14.2
2574	340587.26	5028623.46	103.20	1	DEN	A	84.5	0.0	0.0	0.0	0.0	64.7	1.5	-1.4	0.0	0.0	5.9	0.0	8.3	5.5

Point Source, ISO 9613, Name: "Battery Energy Storage System 021", ID: "I0000!BESS021"																				
Nr.	X	Y	Z	Refl.	DEN	Freq.	Lw	l/a	Optime	K0	Di	Adiv	Aatm	Agr	Afol	Ahous	Abar	Cmet	RL	Lr
	(m)	(m)	(m)			(Hz)	dB(A)	dB	dB	(dB)	(dB)	(dB)	(dB)	(dB)	(dB)	(dB)	(dB)	(dB)	(dB)	dB(A)
2601	340659.40	5028636.32	103.95	0	DEN	A	84.4	0.0	0.0	0.0	0.0	63.9	2.0	-1.1	0.0	0.0	13.2	0.0	0.0	6.4
2604	340659.40	5028636.32	103.95	1	DEN	A	84.4	0.0	0.0	0.0	0.0	64.8	2.2	-1.8	0.0	0.0	4.8	0.0	12.3	2.1

Point Source, ISO 9613, Name: "Battery Energy Storage System 012", ID: "I0001!BESS012"																				
Nr.	X	Y	Z	Refl.	DEN	Freq.	Lw	l/a	Optime	K0	Di	Adiv	Aatm	Agr	Afol	Ahous	Abar	Cmet	RL	Lr
	(m)	(m)	(m)			(Hz)	dB(A)	dB	dB	(dB)	(dB)	(dB)	(dB)	(dB)	(dB)	(dB)	(dB)	(dB)	(dB)	dB(A)
2636	340628.13	5028630.19	103.95	0	DEN	A	84.4	0.0	0.0	0.0	0.0	63.9	2.0	-1.4	0.0	0.0	5.2	0.0	0.0	14.7
2642	340628.13	5028630.19	103.95	1	DEN	A	84.4	0.0	0.0	0.0	0.0	64.3	2.1	-1.4	0.0	0.0	4.9	0.0	2.6	12.0

Point Source, ISO 9613, Name: "Battery Energy Storage System 046", ID: "I0002!BESS046"																				
Nr.	X	Y	Z	Refl.	DEN	Freq.	Lw	l/a	Optime	K0	Di	Adiv	Aatm	Agr	Afol	Ahous	Abar	Cmet	RL	Lr
	(m)	(m)	(m)			(Hz)	dB(A)	dB	dB	(dB)	(dB)	(dB)	(dB)	(dB)	(dB)	(dB)	(dB)	(dB)	(dB)	dB(A)
2670	340597.94	5028625.95	103.95	0	DEN	A	84.4	0.0	0.0	0.0	0.0	63.9	2.0	-1.3	0.0	0.0	10.5	0.0	0.0	9.3
2671	340597.94	5028625.95	103.95	1	DEN	A	84.4	0.0	0.0	0.0	0.0	64.8	2.2	-1.8	0.0	0.0	4.8	0.0	12.3	2.1

Point Source, ISO 9613, Name: "Battery Energy Storage System 306", ID: "I0003!BESS306"																				
Nr.	X	Y	Z	Refl.	DEN	Freq.	Lw	l/a	Optime	K0	Di	Adiv	Aatm	Agr	Afol	Ahous	Abar	Cmet	RL	Lr
	(m)	(m)	(m)			(Hz)	dB(A)	dB	dB	(dB)	(dB)	(dB)	(dB)	(dB)	(dB)	(dB)	(dB)	(dB)	(dB)	dB(A)
2698	340569.57	5028624.79	103.95	0	DEN	A	84.4	0.0	0.0	0.0	0.0	63.9	2.0	-1.4	0.0	0.0	6.5	0.0	0.0	13.4
2704	340569.57	5028624.79	103.95	1	DEN	A	84.4	0.0	0.0	0.0	0.0	64.4	2.1	-1.5	0.0	0.0	0.0	0.0	3.6	15.8

Point Source, ISO 9613, Name: "Battery Energy Storage System 022", ID: "I0000!BESS022"																				
Nr.	X	Y	Z	Refl.	DEN	Freq.	Lw	l/a	Optime	K0	Di	Adiv	Aatm	Agr	Afol	Ahous	Abar	Cmet	RL	Lr
	(m)	(m)	(m)			(Hz)	dB(A)	dB	dB	(dB)	(dB)	(dB)	(dB)	(dB)	(dB)	(dB)	(dB)	(dB)	(dB)	dB(A)
2734	340657.95	5028633.76	103.95	0	DEN	A	84.4	0.0	0.0	0.0	0.0	63.9	2.0	-1.1	0.0	0.0	10.3	0.0	0.0	9.4
2737	340657.95	5028633.76	103.95	1	DEN	A	84.4	0.0	0.0	0.0	0.0	64.8	2.2	-1.8	0.0	0.0	4.8	0.0	12.3	2.2

Point Source, ISO 9613, Name: "Battery Energy Storage System 015", ID: "I0001!BESS015"																				
Nr.	X	Y	Z	Refl.	DEN	Freq.	Lw	l/a	Optime	K0	Di	Adiv	Aatm	Agr	Afol	Ahous	Abar	Cmet	RL	Lr
	(m)	(m)	(m)			(Hz)	dB(A)	dB	dB	(dB)	(dB)	(dB)	(dB)	(dB)	(dB)	(dB)	(dB)	(dB)	(dB)	dB(A)
2765	340636.59	5028628.77	103.95	0	DEN	A	84.4	0.0	0.0	0.0	0.0	63.9	2.0	-1.4	0.0	0.0	5.5	0.0	0.0	14.4
2773	340636.59	5028628.77	103.95	1	DEN	A	84.4	0.0	0.0	0.0	0.0	64.4	2.1	-1.6	0.0	0.0	4.8	0.0	3.7	11.0

Point Source, ISO 9613, Name: "Battery Energy Storage System 049", ID: "I0002!BESS049"																				
Nr.	X	Y	Z	Refl.	DEN	Freq.	Lw	l/a	Optime	K0	Di	Adiv	Aatm	Agr	Afol	Ahous	Abar	Cmet	RL	Lr
	(m)	(m)	(m)			(Hz)	dB(A)	dB	dB	(dB)	(dB)	(dB)	(dB)	(dB)	(dB)	(dB)	(dB)	(dB)	(dB)	dB(A)
2800	340606.40	5028624.54	103.95	0	DEN	A	84.4	0.0	0.0	0.0	0.0	63.9	2.0	-1.2	0.0	0.0	13.5	0.0	0.0	6.3
2801	340606.40	5028624.54	103.95	1	DEN	A	84.4	0.0	0.0	0.0	0.0	65.0	2.2	-1.8	0.0	0.0	4.8	0.0	12.4	2.0

Point Source, ISO 9613, Name: "Medium Voltage Substation 012", ID: "I02!MVT012"																				
Nr.	X	Y	Z	Refl.	DEN	Freq.	Lw	l/a	Optime	K0	Di	Adiv	Aatm	Agr	Afol	Ahous	Abar	Cmet	RL	Lr
	(m)	(m)	(m)			(Hz)	dB(A)	dB	dB	(dB)	(dB)	(dB)	(dB)	(dB)	(dB)	(dB)	(dB)	(dB)	(dB)	dB(A)
2827	340594.27	5028619.48	103.20	0	DEN	A	84.5	0.0	0.0	0.0	0.0	64.0	1.4	-1.2	0.0	0.0	8.2	0.0	0.0	12.1
2829	340594.27	5028619.48	103.20	1	DEN	A	84.5	0.0	0.0	0.0	0.0	64.7	1.5	-1.5	0.0	0.0	5.7	0.0	8.1	5.9

Point Source, ISO 9613, Name: "Medium Voltage Substation 006", ID: "I02!MVT006"																				
Nr.	X	Y	Z	Refl.	DEN	Freq.	Lw	l/a	Optime	K0	Di	Adiv	Aatm	Agr	Afol	Ahous	Abar	Cmet	RL	Lr
	(m)	(m)	(m)			(Hz)	dB(A)	dB	dB	(dB)	(dB)	(dB)	(dB)	(dB)	(dB)	(dB)	(dB)	(dB)	(dB)	dB(A)
2865	340654.28	5028627.29	103.20	0	DEN	A	84.5	0.0	0.0	0.0	0.0	64.0	1.4	-1.0	0.0	0.0	8.0	0.0	0.0	12.0
2867	340654.28	5028627.29	103.20	1	DEN	A	84.5	0.0	0.0	0.0	0.0	64.7	1.5	-1.5	0.0	0.0	6.2	0.0	8.6	5.0
2901	340654.28	5028627.29	103.20	1	DEN	A	84.5	0.0	0.0	0.0	0.0	64.2	1.5	-1.3	0.0	0.0	5.7	0.0	7.1	7.3

Point Source, ISO 9613, Name: "Battery Energy Storage System 307", ID: "I0003!BESS307"																				
Nr.	X	Y	Z	Refl.	DEN	Freq.	Lw	l/a	Optime	K0	Di	Adiv	Aatm	Agr	Afol	Ahous	Abar	Cmet	RL	Lr
	(m)	(m)	(m)			(Hz)	dB(A)	dB	dB	(dB)	(dB)	(dB)	(dB)	(dB)	(dB)	(dB)	(dB)	(dB)	(dB)	dB(A)
2910	340568.12	5028622.23	103.95	0	DEN	A	84.4	0.0	0.0	0.0	0.0	63.9	2.0	-1.4	0.0	0.0	6.4	0.0	0.0	13.5
2913	340568.12	5028622.23	103.95	1	DEN	A	84.4	0.0	0.0	0.0	0.0	64.3	2.1	-1.5	0.0	0.0	0.0	0.0	2.6	17.0

Sample Calculation at POR3 - Regular Operations

Point Source, ISO 9613, Name: "Battery Energy Storage System 025", ID: "!0000!BESS025"																				
Nr.	X	Y	Z	Refl.	DEN	Freq.	Lw	l/a	Optime	K0	Di	Adiv	Aatm	Agr	Afol	Ahous	Abar	Cmet	RL	Lr
	(m)	(m)	(m)			(Hz)	dB(A)	dB	dB	(dB)	(dB)	(dB)	(dB)	(dB)	(dB)	(dB)	(dB)	(dB)	(dB)	dB(A)
2949	340666.41	5028632.34	103.95	0	DEN	A	84.4	0.0	0.0	0.0	0.0	64.0	2.0	-1.1	0.0	0.0	13.2	0.0	0.0	6.3
2958	340666.41	5028632.34	103.95	1	DEN	A	84.4	0.0	0.0	0.0	0.0	64.9	2.2	-1.8	0.0	0.0	4.8	0.0	12.4	2.0

Point Source, ISO 9613, Name: "Battery Energy Storage System 039", ID: "!0003!BESS039"																				
Nr.	X	Y	Z	Refl.	DEN	Freq.	Lw	l/a	Optime	K0	Di	Adiv	Aatm	Agr	Afol	Ahous	Abar	Cmet	RL	Lr
	(m)	(m)	(m)			(Hz)	dB(A)	dB	dB	(dB)	(dB)	(dB)	(dB)	(dB)	(dB)	(dB)	(dB)	(dB)	(dB)	dB(A)
2976	340576.58	5028620.96	103.95	0	DEN	A	84.4	0.0	0.0	0.0	0.0	64.0	2.0	-1.5	0.0	0.0	4.9	0.0	0.0	15.0
2981	340576.58	5028620.96	103.95	1	DEN	A	84.4	0.0	0.0	0.0	0.0	64.5	2.1	-1.7	0.0	0.0	0.0	0.0	3.7	15.8

Point Source, ISO 9613, Name: "Battery Energy Storage System 016", ID: "!0001!BESS016"																				
Nr.	X	Y	Z	Refl.	DEN	Freq.	Lw	l/a	Optime	K0	Di	Adiv	Aatm	Agr	Afol	Ahous	Abar	Cmet	RL	Lr
	(m)	(m)	(m)			(Hz)	dB(A)	dB	dB	(dB)	(dB)	(dB)	(dB)	(dB)	(dB)	(dB)	(dB)	(dB)	(dB)	dB(A)
3006	340635.14	5028626.22	103.95	0	DEN	A	84.4	0.0	0.0	0.0	0.0	64.0	2.0	-1.4	0.0	0.0	5.2	0.0	0.0	14.6
3009	340635.14	5028626.22	103.95	1	DEN	A	84.4	0.0	0.0	0.0	0.0	64.3	2.1	-1.6	0.0	0.0	4.8	0.0	2.6	12.2

Point Source, ISO 9613, Name: "Battery Energy Storage System 050", ID: "!0002!BESS050"																				
Nr.	X	Y	Z	Refl.	DEN	Freq.	Lw	l/a	Optime	K0	Di	Adiv	Aatm	Agr	Afol	Ahous	Abar	Cmet	RL	Lr
	(m)	(m)	(m)			(Hz)	dB(A)	dB	dB	(dB)	(dB)	(dB)	(dB)	(dB)	(dB)	(dB)	(dB)	(dB)	(dB)	dB(A)
3050	340604.95	5028621.98	103.95	0	DEN	A	84.4	0.0	0.0	0.0	0.0	64.0	2.0	-1.3	0.0	0.0	10.4	0.0	0.0	9.3
3051	340604.95	5028621.98	103.95	1	DEN	A	84.4	0.0	0.0	0.0	0.0	64.9	2.2	-1.9	0.0	0.0	4.8	0.0	12.4	2.0

Point Source, ISO 9613, Name: "Battery Energy Storage System 141", ID: "!0006!BESS141"																				
Nr.	X	Y	Z	Refl.	DEN	Freq.	Lw	l/a	Optime	K0	Di	Adiv	Aatm	Agr	Afol	Ahous	Abar	Cmet	RL	Lr
	(m)	(m)	(m)			(Hz)	dB(A)	dB	dB	(dB)	(dB)	(dB)	(dB)	(dB)	(dB)	(dB)	(dB)	(dB)	(dB)	dB(A)
3078	340431.33	5028640.12	103.95	0	DEN	A	84.4	0.0	0.0	0.0	0.0	64.0	2.0	-0.7	0.0	0.0	9.6	0.0	0.0	9.5

Point Source, ISO 9613, Name: "Battery Energy Storage System 026", ID: "!0000!BESS026"																				
Nr.	X	Y	Z	Refl.	DEN	Freq.	Lw	l/a	Optime	K0	Di	Adiv	Aatm	Agr	Afol	Ahous	Abar	Cmet	RL	Lr
	(m)	(m)	(m)			(Hz)	dB(A)	dB	dB	(dB)	(dB)	(dB)	(dB)	(dB)	(dB)	(dB)	(dB)	(dB)	(dB)	dB(A)
3094	340664.96	5028629.79	103.95	0	DEN	A	84.4	0.0	0.0	0.0	0.0	64.0	2.0	-1.1	0.0	0.0	10.2	0.0	0.0	9.3
3103	340664.96	5028629.79	103.95	1	DEN	A	84.4	0.0	0.0	0.0	0.0	64.9	2.2	-1.8	0.0	0.0	4.8	0.0	12.3	2.1

Point Source, ISO 9613, Name: "Battery Energy Storage System 040", ID: "!0003!BESS040"																				
Nr.	X	Y	Z	Refl.	DEN	Freq.	Lw	l/a	Optime	K0	Di	Adiv	Aatm	Agr	Afol	Ahous	Abar	Cmet	RL	Lr
	(m)	(m)	(m)			(Hz)	dB(A)	dB	dB	(dB)	(dB)	(dB)	(dB)	(dB)	(dB)	(dB)	(dB)	(dB)	(dB)	dB(A)
3132	340575.13	5028618.41	103.95	0	DEN	A	84.4	0.0	0.0	0.0	0.0	64.0	2.0	-1.5	0.0	0.0	4.9	0.0	0.0	15.0
3137	340575.13	5028618.41	103.95	1	DEN	A	84.4	0.0	0.0	0.0	0.0	64.4	2.1	-1.6	0.0	0.0	4.9	0.0	2.6	12.1

Point Source, ISO 9613, Name: "Medium Voltage Substation 013", ID: "!02!MVT013"																				
Nr.	X	Y	Z	Refl.	DEN	Freq.	Lw	l/a	Optime	K0	Di	Adiv	Aatm	Agr	Afol	Ahous	Abar	Cmet	RL	Lr
	(m)	(m)	(m)			(Hz)	dB(A)	dB	dB	(dB)	(dB)	(dB)	(dB)	(dB)	(dB)	(dB)	(dB)	(dB)	(dB)	dB(A)
3173	340601.28	5028615.51	103.20	0	DEN	A	84.5	0.0	0.0	0.0	0.0	64.1	1.4	-1.3	0.0	0.0	8.2	0.0	0.0	12.1
3175	340601.28	5028615.51	103.20	1	DEN	A	84.5	0.0	0.0	0.0	0.0	64.8	1.5	-1.6	0.0	0.0	5.6	0.0	8.1	6.1

Point Source, ISO 9613, Name: "Battery Energy Storage System 053", ID: "!0002!BESS053"																				
Nr.	X	Y	Z	Refl.	DEN	Freq.	Lw	l/a	Optime	K0	Di	Adiv	Aatm	Agr	Afol	Ahous	Abar	Cmet	RL	Lr
	(m)	(m)	(m)			(Hz)	dB(A)	dB	dB	(dB)	(dB)	(dB)	(dB)	(dB)	(dB)	(dB)	(dB)	(dB)	(dB)	dB(A)
3214	340613.41	5028620.56	103.95	0	DEN	A	84.4	0.0	0.0	0.0	0.0	64.0	2.0	-1.3	0.0	0.0	13.4	0.0	0.0	6.2
3215	340613.41	5028620.56	103.95	1	DEN	A	84.4	0.0	0.0	0.0	0.0	65.0	2.2	-1.9	0.0	0.0	4.8	0.0	12.4	1.9

Point Source, ISO 9613, Name: "Battery Energy Storage System 019", ID: "!0001!BESS019"																				
Nr.	X	Y	Z	Refl.	DEN	Freq.	Lw	l/a	Optime	K0	Di	Adiv	Aatm	Agr	Afol	Ahous	Abar	Cmet	RL	Lr
	(m)	(m)	(m)			(Hz)	dB(A)	dB	dB	(dB)	(dB)	(dB)	(dB)	(dB)	(dB)	(dB)	(dB)	(dB)	(dB)	dB(A)
3238	340643.60	5028624.80	103.95	0	DEN	A	84.4	0.0	0.0	0.0	0.0	64.0	2.0	-1.3	0.0	0.0	5.5	0.0	0.0	14.2
3244	340643.60	5028624.80	103.95	1	DEN	A	84.4	0.0	0.0	0.0	0.0	64.5	2.1	-1.7	0.0	0.0	4.8	0.0	3.7	11.0

Point Source, ISO 9613, Name: "Battery Energy Storage System 145", ID: "!0006!BESS145"																				
Nr.	X	Y	Z	Refl.	DEN	Freq.	Lw	l/a	Optime	K0	Di	Adiv	Aatm	Agr	Afol	Ahous	Abar	Cmet	RL	Lr
	(m)	(m)	(m)			(Hz)	dB(A)	dB	dB	(dB)	(dB)	(dB)	(dB)	(dB)	(dB)	(dB)	(dB)	(dB)	(dB)	dB(A)
3270	340438.34	5028636.15	103.95	0	DEN	A	84.4	0.0	0.0	0.0	0.0	64.0	2.0	-0.7	0.0	0.0	10.1	0.0	0.0	8.9
3283	340438.34	5028636.15	103.95	1	DEN	A	84.4	0.0	0.0	0.0	0.0	65.2	2.2	-1.6	0.0	0.0	4.8	0.0	12.5	1.3

Sample Calculation at POR3 - Regular Operations

Point Source, ISO 9613, Name: "Medium Voltage Substation 007", ID: "!02!MVT007"																				
Nr.	X	Y	Z	Refl.	DEN	Freq.	Lw	l/a	Optime	K0	Di	Adiv	Aatm	Agr	Afol	Ahous	Abar	Cmet	RL	Lr
	(m)	(m)	(m)			(Hz)	dB(A)	dB	dB	(dB)	(dB)	(dB)	(dB)	(dB)	(dB)	(dB)	(dB)	(dB)	(dB)	dB(A)
3309	340661.29	5028623.32	103.20	0	DEN	A	84.5	0.0	0.0	0.0	0.0	64.1	1.4	-1.1	0.0	0.0	8.0	0.0	0.0	12.0
3318	340661.29	5028623.32	103.20	1	DEN	A	84.5	0.0	0.0	0.0	0.0	64.8	1.5	-1.5	0.0	0.0	6.3	0.0	8.6	4.7
3354	340661.29	5028623.32	103.20	1	DEN	A	84.5	0.0	0.0	0.0	0.0	64.3	1.5	-1.3	0.0	0.0	5.7	0.0	7.1	7.2

Point Source, ISO 9613, Name: "Battery Energy Storage System 043", ID: "!0003!BESS043"																				
Nr.	X	Y	Z	Refl.	DEN	Freq.	Lw	l/a	Optime	K0	Di	Adiv	Aatm	Agr	Afol	Ahous	Abar	Cmet	RL	Lr
	(m)	(m)	(m)			(Hz)	dB(A)	dB	dB	(dB)	(dB)	(dB)	(dB)	(dB)	(dB)	(dB)	(dB)	(dB)	(dB)	dB(A)
3364	340583.59	5028616.99	103.95	0	DEN	A	84.4	0.0	0.0	0.0	0.0	64.0	2.0	-1.5	0.0	0.0	4.9	0.0	0.0	14.9
3367	340583.59	5028616.99	103.95	1	DEN	A	84.4	0.0	0.0	0.0	0.0	64.5	2.1	-1.7	0.0	0.0	4.8	0.0	3.7	11.0

Point Source, ISO 9613, Name: "Battery Energy Storage System 142", ID: "!0006!BESS142"																				
Nr.	X	Y	Z	Refl.	DEN	Freq.	Lw	l/a	Optime	K0	Di	Adiv	Aatm	Agr	Afol	Ahous	Abar	Cmet	RL	Lr
	(m)	(m)	(m)			(Hz)	dB(A)	dB	dB	(dB)	(dB)	(dB)	(dB)	(dB)	(dB)	(dB)	(dB)	(dB)	(dB)	dB(A)
3395	340429.89	5028637.56	103.95	0	DEN	A	84.4	0.0	0.0	0.0	0.0	64.1	2.0	-0.7	0.0	0.0	7.2	0.0	0.0	11.9

Point Source, ISO 9613, Name: "Battery Energy Storage System 020", ID: "!0001!BESS020"																				
Nr.	X	Y	Z	Refl.	DEN	Freq.	Lw	l/a	Optime	K0	Di	Adiv	Aatm	Agr	Afol	Ahous	Abar	Cmet	RL	Lr
	(m)	(m)	(m)			(Hz)	dB(A)	dB	dB	(dB)	(dB)	(dB)	(dB)	(dB)	(dB)	(dB)	(dB)	(dB)	(dB)	dB(A)
3414	340642.15	5028622.24	103.95	0	DEN	A	84.4	0.0	0.0	0.0	0.0	64.1	2.0	-1.4	0.0	0.0	5.2	0.0	0.0	14.5
3420	340642.15	5028622.24	103.95	1	DEN	A	84.4	0.0	0.0	0.0	0.0	64.4	2.1	-1.7	0.0	0.0	4.8	0.0	3.7	11.1

Point Source, ISO 9613, Name: "Battery Energy Storage System 054", ID: "!0002!BESS054"																				
Nr.	X	Y	Z	Refl.	DEN	Freq.	Lw	l/a	Optime	K0	Di	Adiv	Aatm	Agr	Afol	Ahous	Abar	Cmet	RL	Lr
	(m)	(m)	(m)			(Hz)	dB(A)	dB	dB	(dB)	(dB)	(dB)	(dB)	(dB)	(dB)	(dB)	(dB)	(dB)	(dB)	dB(A)
3451	340611.96	5028618.00	103.95	0	DEN	A	84.4	0.0	0.0	0.0	0.0	64.1	2.0	-1.3	0.0	0.0	10.4	0.0	0.0	9.2
3454	340611.96	5028618.00	103.95	1	DEN	A	84.4	0.0	0.0	0.0	0.0	65.0	2.2	-1.8	0.0	0.0	4.8	0.0	12.4	1.9

Point Source, ISO 9613, Name: "Battery Energy Storage System 149", ID: "!0006!BESS149"																				
Nr.	X	Y	Z	Refl.	DEN	Freq.	Lw	l/a	Optime	K0	Di	Adiv	Aatm	Agr	Afol	Ahous	Abar	Cmet	RL	Lr
	(m)	(m)	(m)			(Hz)	dB(A)	dB	dB	(dB)	(dB)	(dB)	(dB)	(dB)	(dB)	(dB)	(dB)	(dB)	(dB)	dB(A)
3479	340445.35	5028632.17	103.95	0	DEN	A	84.4	0.0	0.0	0.0	0.0	64.1	2.0	-0.7	0.0	0.0	10.3	0.0	0.0	8.7
3492	340445.35	5028632.17	103.95	1	DEN	A	84.4	0.0	0.0	0.0	0.0	65.2	2.3	-1.6	0.0	0.0	4.8	0.0	12.5	1.3

Point Source, ISO 9613, Name: "Battery Energy Storage System 029", ID: "!0000!BESS029"																				
Nr.	X	Y	Z	Refl.	DEN	Freq.	Lw	l/a	Optime	K0	Di	Adiv	Aatm	Agr	Afol	Ahous	Abar	Cmet	RL	Lr
	(m)	(m)	(m)			(Hz)	dB(A)	dB	dB	(dB)	(dB)	(dB)	(dB)	(dB)	(dB)	(dB)	(dB)	(dB)	(dB)	dB(A)
3519	340673.42	5028628.37	103.95	0	DEN	A	84.4	0.0	0.0	0.0	0.0	64.1	2.0	-1.1	0.0	0.0	13.2	0.0	0.0	6.2
3522	340673.42	5028628.37	103.95	1	DEN	A	84.4	0.0	0.0	0.0	0.0	65.0	2.2	-1.9	0.0	0.0	4.8	0.0	12.4	1.9

Point Source, ISO 9613, Name: "Battery Energy Storage System 146", ID: "!0006!BESS146"																				
Nr.	X	Y	Z	Refl.	DEN	Freq.	Lw	l/a	Optime	K0	Di	Adiv	Aatm	Agr	Afol	Ahous	Abar	Cmet	RL	Lr
	(m)	(m)	(m)			(Hz)	dB(A)	dB	dB	(dB)	(dB)	(dB)	(dB)	(dB)	(dB)	(dB)	(dB)	(dB)	(dB)	dB(A)
3538	340436.90	5028633.59	103.95	0	DEN	A	84.4	0.0	0.0	0.0	0.0	64.1	2.0	-0.7	0.0	0.0	7.7	0.0	0.0	11.3
3547	340436.90	5028633.59	103.95	1	DEN	A	84.4	0.0	0.0	0.0	0.0	65.2	2.2	-1.6	0.0	0.0	4.8	0.0	3.7	10.1

Point Source, ISO 9613, Name: "Battery Energy Storage System 044", ID: "!0003!BESS044"																				
Nr.	X	Y	Z	Refl.	DEN	Freq.	Lw	l/a	Optime	K0	Di	Adiv	Aatm	Agr	Afol	Ahous	Abar	Cmet	RL	Lr
	(m)	(m)	(m)			(Hz)	dB(A)	dB	dB	(dB)	(dB)	(dB)	(dB)	(dB)	(dB)	(dB)	(dB)	(dB)	(dB)	dB(A)
3567	340582.14	5028614.43	103.95	0	DEN	A	84.4	0.0	0.0	0.0	0.0	64.1	2.0	-1.5	0.0	0.0	4.9	0.0	0.0	15.0
3574	340582.14	5028614.43	103.95	1	DEN	A	84.4	0.0	0.0	0.0	0.0	64.5	2.1	-1.7	0.0	0.0	4.8	0.0	2.6	12.1

Point Source, ISO 9613, Name: "Battery Energy Storage System 153", ID: "!0006!BESS153"																				
Nr.	X	Y	Z	Refl.	DEN	Freq.	Lw	l/a	Optime	K0	Di	Adiv	Aatm	Agr	Afol	Ahous	Abar	Cmet	RL	Lr
	(m)	(m)	(m)			(Hz)	dB(A)	dB	dB	(dB)	(dB)	(dB)	(dB)	(dB)	(dB)	(dB)	(dB)	(dB)	(dB)	dB(A)
3603	340451.93	5028628.45	103.95	0	DEN	A	84.4	0.0	0.0	0.0	0.0	64.1	2.0	-0.9	0.0	0.0	10.3	0.0	0.0	8.8
3623	340451.93	5028628.45	103.95	1	DEN	A	84.4	0.0	0.0	0.0	0.0	65.3	2.3	-1.6	0.0	0.0	4.8	0.0	12.5	1.3

Point Source, ISO 9613, Name: "Medium Voltage Substation 014", ID: "!02!MVT014"																				
Nr.	X	Y	Z	Refl.	DEN	Freq.	Lw	l/a	Optime	K0	Di	Adiv	Aatm	Agr	Afol	Ahous	Abar	Cmet	RL	Lr
	(m)	(m)	(m)			(Hz)	dB(A)	dB	dB	(dB)	(dB)	(dB)	(dB)	(dB)	(dB)	(dB)	(dB)	(dB)	(dB)	dB(A)
3644	340608.29	5028611.53	103.20	0	DEN	A	84.5	0.0	0.0	0.0	0.0	64.2	1.5	-1.3	0.0	0.0	8.1	0.0	0.0	12.0
3646	340608.29	5028611.53	103.20	1	DEN	A	84.5	0.0	0.0	0.0	0.0	64.9	1.6	-1.6	0.0	0.0	5.6	0.0	8.1	6.0

Sample Calculation at POR3 - Regular Operations

Point Source, ISO 9613, Name: "Battery Energy Storage System 057", ID: "I0002!BESS057"																				
Nr.	X	Y	Z	Refl.	DEN	Freq.	Lw	l/a	Optime	K0	Di	Adiv	Aatm	Agr	Afol	Ahous	Abar	Cmet	RL	Lr
	(m)	(m)	(m)			(Hz)	dB(A)	dB	dB	(dB)	(dB)	(dB)	(dB)	(dB)	(dB)	(dB)	(dB)	(dB)	(dB)	dB(A)
3682	340620.42	5028616.59	103.95	0	DEN	A	84.4	0.0	0.0	0.0	0.0	64.1	2.0	-1.4	0.0	0.0	13.4	0.0	0.0	6.2
3684	340620.42	5028616.59	103.95	1	DEN	A	84.4	0.0	0.0	0.0	0.0	65.1	2.2	-1.9	0.0	0.0	4.8	0.0	12.4	1.7

Point Source, ISO 9613, Name: "Battery Energy Storage System 030", ID: "I0000!BESS030"																				
Nr.	X	Y	Z	Refl.	DEN	Freq.	Lw	l/a	Optime	K0	Di	Adiv	Aatm	Agr	Afol	Ahous	Abar	Cmet	RL	Lr
	(m)	(m)	(m)			(Hz)	dB(A)	dB	dB	(dB)	(dB)	(dB)	(dB)	(dB)	(dB)	(dB)	(dB)	(dB)	(dB)	dB(A)
3713	340671.97	5028625.81	103.95	0	DEN	A	84.4	0.0	0.0	0.0	0.0	64.1	2.0	-1.1	0.0	0.0	10.2	0.0	0.0	9.2
3723	340671.97	5028625.81	103.95	1	DEN	A	84.4	0.0	0.0	0.0	0.0	64.9	2.2	-1.9	0.0	0.0	4.8	0.0	12.4	2.0

Point Source, ISO 9613, Name: "Medium Voltage Substation 037", ID: "I02!MVT037"																				
Nr.	X	Y	Z	Refl.	DEN	Freq.	Lw	l/a	Optime	K0	Di	Adiv	Aatm	Agr	Afol	Ahous	Abar	Cmet	RL	Lr
	(m)	(m)	(m)			(Hz)	dB(A)	dB	dB	(dB)	(dB)	(dB)	(dB)	(dB)	(dB)	(dB)	(dB)	(dB)	(dB)	dB(A)
3738	340426.22	5028631.09	103.20	0	DEN	A	84.5	0.0	0.0	0.0	0.0	64.2	1.5	0.1	0.0	0.0	4.9	0.0	0.0	13.9
3746	340426.22	5028631.09	103.20	1	DEN	A	84.5	0.0	0.0	0.0	0.0	65.0	1.6	-1.3	0.0	0.0	5.2	0.0	7.9	6.1
3759	340426.22	5028631.09	103.20	1	DEN	A	84.5	0.0	0.0	0.0	0.0	64.5	1.5	-0.5	0.0	0.0	5.0	0.0	6.7	7.2
3760	340426.22	5028631.09	103.20	1	DEN	A	84.5	0.0	0.0	0.0	0.0	64.4	1.5	-0.3	0.0	0.0	4.5	0.0	6.1	8.4

Point Source, ISO 9613, Name: "Battery Energy Storage System 023", ID: "I0001!BESS023"																				
Nr.	X	Y	Z	Refl.	DEN	Freq.	Lw	l/a	Optime	K0	Di	Adiv	Aatm	Agr	Afol	Ahous	Abar	Cmet	RL	Lr
	(m)	(m)	(m)			(Hz)	dB(A)	dB	dB	(dB)	(dB)	(dB)	(dB)	(dB)	(dB)	(dB)	(dB)	(dB)	(dB)	dB(A)
3765	340650.61	5028620.82	103.95	0	DEN	A	84.4	0.0	0.0	0.0	0.0	64.1	2.0	-1.4	0.0	0.0	5.5	0.0	0.0	14.1
3769	340650.61	5028620.82	103.95	1	DEN	A	84.4	0.0	0.0	0.0	0.0	64.6	2.1	-1.7	0.0	0.0	4.8	0.0	3.7	11.0

Point Source, ISO 9613, Name: "Battery Energy Storage System 150", ID: "I0006!BESS150"																				
Nr.	X	Y	Z	Refl.	DEN	Freq.	Lw	l/a	Optime	K0	Di	Adiv	Aatm	Agr	Afol	Ahous	Abar	Cmet	RL	Lr
	(m)	(m)	(m)			(Hz)	dB(A)	dB	dB	(dB)	(dB)	(dB)	(dB)	(dB)	(dB)	(dB)	(dB)	(dB)	(dB)	dB(A)
3793	340443.91	5028629.61	103.95	0	DEN	A	84.4	0.0	0.0	0.0	0.0	64.1	2.0	-0.7	0.0	0.0	7.8	0.0	0.0	11.1
3807	340443.91	5028629.61	103.95	1	DEN	A	84.4	0.0	0.0	0.0	0.0	65.2	2.2	-1.6	0.0	0.0	4.8	0.0	3.7	10.1

Point Source, ISO 9613, Name: "Battery Energy Storage System 085", ID: "I0004!BESS085"																				
Nr.	X	Y	Z	Refl.	DEN	Freq.	Lw	l/a	Optime	K0	Di	Adiv	Aatm	Agr	Afol	Ahous	Abar	Cmet	RL	Lr
	(m)	(m)	(m)			(Hz)	dB(A)	dB	dB	(dB)	(dB)	(dB)	(dB)	(dB)	(dB)	(dB)	(dB)	(dB)	(dB)	dB(A)
3827	340553.40	5028612.75	103.95	0	DEN	A	84.4	0.0	0.0	0.0	0.0	64.1	2.0	-1.4	0.0	0.0	10.1	0.0	0.0	9.5

Point Source, ISO 9613, Name: "Battery Energy Storage System 047", ID: "I0003!BESS047"																				
Nr.	X	Y	Z	Refl.	DEN	Freq.	Lw	l/a	Optime	K0	Di	Adiv	Aatm	Agr	Afol	Ahous	Abar	Cmet	RL	Lr
	(m)	(m)	(m)			(Hz)	dB(A)	dB	dB	(dB)	(dB)	(dB)	(dB)	(dB)	(dB)	(dB)	(dB)	(dB)	(dB)	dB(A)
3878	340590.60	5028613.01	103.95	0	DEN	A	84.4	0.0	0.0	0.0	0.0	64.1	2.0	-1.5	0.0	0.0	4.9	0.0	0.0	14.8
3881	340590.60	5028613.01	103.95	1	DEN	A	84.4	0.0	0.0	0.0	0.0	64.6	2.1	-1.8	0.0	0.0	4.8	0.0	3.7	11.0

Point Source, ISO 9613, Name: "Medium Voltage Substation 008", ID: "I02!MVT008"																				
Nr.	X	Y	Z	Refl.	DEN	Freq.	Lw	l/a	Optime	K0	Di	Adiv	Aatm	Agr	Afol	Ahous	Abar	Cmet	RL	Lr
	(m)	(m)	(m)			(Hz)	dB(A)	dB	dB	(dB)	(dB)	(dB)	(dB)	(dB)	(dB)	(dB)	(dB)	(dB)	(dB)	dB(A)
3906	340668.30	5028619.34	103.20	0	DEN	A	84.5	0.0	0.0	0.0	0.0	64.2	1.5	-1.1	0.0	0.0	8.0	0.0	0.0	11.9
3919	340668.30	5028619.34	103.20	1	DEN	A	84.5	0.0	0.0	0.0	0.0	64.8	1.5	-1.5	0.0	0.0	6.3	0.0	8.7	4.5
3945	340668.30	5028619.34	103.20	1	DEN	A	84.5	0.0	0.0	0.0	0.0	64.4	1.5	-1.3	0.0	0.0	5.7	0.0	7.1	7.1

Point Source, ISO 9613, Name: "Battery Energy Storage System 157", ID: "I0006!BESS157"																				
Nr.	X	Y	Z	Refl.	DEN	Freq.	Lw	l/a	Optime	K0	Di	Adiv	Aatm	Agr	Afol	Ahous	Abar	Cmet	RL	Lr
	(m)	(m)	(m)			(Hz)	dB(A)	dB	dB	(dB)	(dB)	(dB)	(dB)	(dB)	(dB)	(dB)	(dB)	(dB)	(dB)	dB(A)
3949	340458.94	5028624.47	103.95	0	DEN	A	84.4	0.0	0.0	0.0	0.0	64.1	2.0	-1.3	0.0	0.0	10.5	0.0	0.0	9.1
3959	340458.94	5028624.47	103.95	1	DEN	A	84.4	0.0	0.0	0.0	0.0	65.3	2.3	-1.6	0.0	0.0	4.8	0.0	12.5	1.2

Point Source, ISO 9613, Name: "Medium Voltage Substation 038", ID: "I02!MVT038"																				
Nr.	X	Y	Z	Refl.	DEN	Freq.	Lw	l/a	Optime	K0	Di	Adiv	Aatm	Agr	Afol	Ahous	Abar	Cmet	RL	Lr
	(m)	(m)	(m)			(Hz)	dB(A)	dB	dB	(dB)	(dB)	(dB)	(dB)	(dB)	(dB)	(dB)	(dB)	(dB)	(dB)	dB(A)
3996	340433.21	5028627.13	103.20	0	DEN	A	84.5	0.0	0.0	0.0	0.0	64.2	1.5	0.0	0.0	0.0	5.9	0.0	0.0	12.9
4001	340433.21	5028627.13	103.20	1	DEN	A	84.5	0.0	0.0	0.0	0.0	65.0	1.6	-1.4	0.0	0.0	6.3	0.0	8.8	4.2
4004	340433.21	5028627.13	103.20	2	DEN	A	84.5	0.0	0.0	0.0	0.0	65.2	1.6	-1.4	0.0	0.0	4.8	0.0	13.9	0.3
4028	340433.21	5028627.13	103.20	1	DEN	A	84.5	0.0	0.0	0.0	0.0	64.5	1.5	-0.3	0.0	0.0	4.8	0.0	6.4	7.7

Sample Calculation at POR3 - Regular Operations

Point Source, ISO 9613, Name: "Battery Energy Storage System 058", ID: "!0002!BESS058"																				
Nr.	X	Y	Z	Refl.	DEN	Freq.	Lw	l/a	Optime	K0	Di	Adiv	Aatm	Agr	Afol	Ahous	Abar	Cmet	RL	Lr
	(m)	(m)	(m)			(Hz)	dB(A)	dB	dB	(dB)	(dB)	(dB)	(dB)	(dB)	(dB)	(dB)	(dB)	(dB)	(dB)	dB(A)
4037	340618.97	5028614.03	103.95	0	DEN	A	84.4	0.0	0.0	0.0	0.0	64.2	2.0	-1.4	0.0	0.0	10.4	0.0	0.0	9.2
4038	340618.97	5028614.03	103.95	1	DEN	A	84.4	0.0	0.0	0.0	0.0	65.1	2.2	-1.9	0.0	0.0	4.8	0.0	12.4	1.8

Point Source, ISO 9613, Name: "Battery Energy Storage System 154", ID: "!0006!BESS154"																				
Nr.	X	Y	Z	Refl.	DEN	Freq.	Lw	l/a	Optime	K0	Di	Adiv	Aatm	Agr	Afol	Ahous	Abar	Cmet	RL	Lr
	(m)	(m)	(m)			(Hz)	dB(A)	dB	dB	(dB)	(dB)	(dB)	(dB)	(dB)	(dB)	(dB)	(dB)	(dB)	(dB)	dB(A)
4072	340450.48	5028625.89	103.95	0	DEN	A	84.4	0.0	0.0	0.0	0.0	64.2	2.0	-0.9	0.0	0.0	7.9	0.0	0.0	11.2
4082	340450.48	5028625.89	103.95	1	DEN	A	84.4	0.0	0.0	0.0	0.0	65.2	2.2	-1.6	0.0	0.0	4.8	0.0	3.7	10.1

Point Source, ISO 9613, Name: "Battery Energy Storage System 024", ID: "!0001!BESS024"																				
Nr.	X	Y	Z	Refl.	DEN	Freq.	Lw	l/a	Optime	K0	Di	Adiv	Aatm	Agr	Afol	Ahous	Abar	Cmet	RL	Lr
	(m)	(m)	(m)			(Hz)	dB(A)	dB	dB	(dB)	(dB)	(dB)	(dB)	(dB)	(dB)	(dB)	(dB)	(dB)	(dB)	dB(A)
4104	340649.16	5028618.27	103.95	0	DEN	A	84.4	0.0	0.0	0.0	0.0	64.2	2.0	-1.4	0.0	0.0	5.3	0.0	0.0	14.4
4109	340649.16	5028618.27	103.95	1	DEN	A	84.4	0.0	0.0	0.0	0.0	64.5	2.1	-1.7	0.0	0.0	4.8	0.0	3.7	11.0

Point Source, ISO 9613, Name: "Battery Energy Storage System 086", ID: "!0004!BESS086"																				
Nr.	X	Y	Z	Refl.	DEN	Freq.	Lw	l/a	Optime	K0	Di	Adiv	Aatm	Agr	Afol	Ahous	Abar	Cmet	RL	Lr
	(m)	(m)	(m)			(Hz)	dB(A)	dB	dB	(dB)	(dB)	(dB)	(dB)	(dB)	(dB)	(dB)	(dB)	(dB)	(dB)	dB(A)
4145	340551.95	5028610.20	103.95	0	DEN	A	84.4	0.0	0.0	0.0	0.0	64.2	2.0	-1.4	0.0	0.0	7.6	0.0	0.0	11.9

Point Source, ISO 9613, Name: "Battery Energy Storage System 048", ID: "!0003!BESS048"																				
Nr.	X	Y	Z	Refl.	DEN	Freq.	Lw	l/a	Optime	K0	Di	Adiv	Aatm	Agr	Afol	Ahous	Abar	Cmet	RL	Lr
	(m)	(m)	(m)			(Hz)	dB(A)	dB	dB	(dB)	(dB)	(dB)	(dB)	(dB)	(dB)	(dB)	(dB)	(dB)	(dB)	dB(A)
4185	340589.15	5028610.46	103.95	0	DEN	A	84.4	0.0	0.0	0.0	0.0	64.2	2.0	-1.6	0.0	0.0	4.8	0.0	0.0	14.9
4190	340589.15	5028610.46	103.95	1	DEN	A	84.4	0.0	0.0	0.0	0.0	64.6	2.1	-1.8	0.0	0.0	4.8	0.0	2.6	12.1

Point Source, ISO 9613, Name: "Battery Energy Storage System 033", ID: "!0000!BESS033"																				
Nr.	X	Y	Z	Refl.	DEN	Freq.	Lw	l/a	Optime	K0	Di	Adiv	Aatm	Agr	Afol	Ahous	Abar	Cmet	RL	Lr
	(m)	(m)	(m)			(Hz)	dB(A)	dB	dB	(dB)	(dB)	(dB)	(dB)	(dB)	(dB)	(dB)	(dB)	(dB)	(dB)	dB(A)
4222	340680.42	5028624.40	103.95	0	DEN	A	84.4	0.0	0.0	0.0	0.0	64.2	2.0	-1.1	0.0	0.0	13.2	0.0	0.0	6.1
4229	340680.42	5028624.40	103.95	1	DEN	A	84.4	0.0	0.0	0.0	0.0	65.1	2.2	-1.9	0.0	0.0	4.8	0.0	12.4	1.8

Point Source, ISO 9613, Name: "Medium Voltage Substation 039", ID: "!02!MVT039"																				
Nr.	X	Y	Z	Refl.	DEN	Freq.	Lw	l/a	Optime	K0	Di	Adiv	Aatm	Agr	Afol	Ahous	Abar	Cmet	RL	Lr
	(m)	(m)	(m)			(Hz)	dB(A)	dB	dB	(dB)	(dB)	(dB)	(dB)	(dB)	(dB)	(dB)	(dB)	(dB)	(dB)	dB(A)
4247	340440.34	5028623.06	103.20	0	DEN	A	84.5	0.0	0.0	0.0	0.0	64.3	1.5	0.0	0.0	0.0	5.9	0.0	0.0	12.8
4263	340440.34	5028623.06	103.20	1	DEN	A	84.5	0.0	0.0	0.0	0.0	65.1	1.6	-1.4	0.0	0.0	6.3	0.0	8.8	4.2
4281	340440.34	5028623.06	103.20	1	DEN	A	84.5	0.0	0.0	0.0	0.0	64.5	1.5	-0.3	0.0	0.0	4.8	0.0	6.4	7.6

Point Source, ISO 9613, Name: "Battery Energy Storage System 161", ID: "!0006!BESS161"																				
Nr.	X	Y	Z	Refl.	DEN	Freq.	Lw	l/a	Optime	K0	Di	Adiv	Aatm	Agr	Afol	Ahous	Abar	Cmet	RL	Lr
	(m)	(m)	(m)			(Hz)	dB(A)	dB	dB	(dB)	(dB)	(dB)	(dB)	(dB)	(dB)	(dB)	(dB)	(dB)	(dB)	dB(A)
4291	340465.95	5028620.50	103.95	0	DEN	A	84.4	0.0	0.0	0.0	0.0	64.2	2.0	-1.6	0.0	0.0	10.5	0.0	0.0	9.3
4304	340465.95	5028620.50	103.95	1	DEN	A	84.4	0.0	0.0	0.0	0.0	65.3	2.3	-1.7	0.0	0.0	4.8	0.0	12.5	1.2

Point Source, ISO 9613, Name: "Medium Voltage Substation 015", ID: "!02!MVT015"																				
Nr.	X	Y	Z	Refl.	DEN	Freq.	Lw	l/a	Optime	K0	Di	Adiv	Aatm	Agr	Afol	Ahous	Abar	Cmet	RL	Lr
	(m)	(m)	(m)			(Hz)	dB(A)	dB	dB	(dB)	(dB)	(dB)	(dB)	(dB)	(dB)	(dB)	(dB)	(dB)	(dB)	dB(A)
4340	340615.30	5028607.56	103.20	0	DEN	A	84.5	0.0	0.0	0.0	0.0	64.3	1.5	-1.3	0.0	0.0	8.1	0.0	0.0	12.0
4341	340615.30	5028607.56	103.20	1	DEN	A	84.5	0.0	0.0	0.0	0.0	65.0	1.6	-1.6	0.0	0.0	5.6	0.0	8.1	5.9

Point Source, ISO 9613, Name: "Battery Energy Storage System 158", ID: "!0006!BESS158"																				
Nr.	X	Y	Z	Refl.	DEN	Freq.	Lw	l/a	Optime	K0	Di	Adiv	Aatm	Agr	Afol	Ahous	Abar	Cmet	RL	Lr
	(m)	(m)	(m)			(Hz)	dB(A)	dB	dB	(dB)	(dB)	(dB)	(dB)	(dB)	(dB)	(dB)	(dB)	(dB)	(dB)	dB(A)
4384	340457.49	5028621.91	103.95	0	DEN	A	84.4	0.0	0.0	0.0	0.0	64.2	2.0	-1.3	0.0	0.0	8.0	0.0	0.0	11.5
4397	340457.49	5028621.91	103.95	1	DEN	A	84.4	0.0	0.0	0.0	0.0	65.2	2.3	-1.6	0.0	0.0	4.8	0.0	3.7	10.0

Point Source, ISO 9613, Name: "Battery Energy Storage System 089", ID: "!0004!BESS089"																				
Nr.	X	Y	Z	Refl.	DEN	Freq.	Lw	l/a	Optime	K0	Di	Adiv	Aatm	Agr	Afol	Ahous	Abar	Cmet	RL	Lr
	(m)	(m)	(m)			(Hz)	dB(A)	dB	dB	(dB)	(dB)	(dB)	(dB)	(dB)	(dB)	(dB)	(dB)	(dB)	(dB)	dB(A)
4434	340560.41	5028608.78	103.95	0	DEN	A	84.4	0.0	0.0	0.0	0.0	64.2	2.0	-1.5	0.0	0.0	10.1	0.0	0.0	9.6

Sample Calculation at POR3 - Regular Operations

Point Source, ISO 9613, Name: "Battery Energy Storage System 061", ID: "I0002!BESS061"																				
Nr.	X	Y	Z	Refl.	DEN	Freq.	Lw	l/a	Optime	K0	Di	Adiv	Aatm	Agr	Afol	Ahous	Abar	Cmet	RL	Lr
	(m)	(m)	(m)			(Hz)	dB(A)	dB	dB	(dB)	(dB)	(dB)	(dB)	(dB)	(dB)	(dB)	(dB)	(dB)	(dB)	dB(A)
4476	340627.43	5028612.61	103.95	0	DEN	A	84.4	0.0	0.0	0.0	0.0	64.2	2.1	-1.6	0.0	0.0	13.4	0.0	0.0	6.3
4477	340627.43	5028612.61	103.95	1	DEN	A	84.4	0.0	0.0	0.0	0.0	65.2	2.2	-1.9	0.0	0.0	4.8	0.0	12.5	1.6

Point Source, ISO 9613, Name: "Battery Energy Storage System 051", ID: "I0003!BESS051"																				
Nr.	X	Y	Z	Refl.	DEN	Freq.	Lw	l/a	Optime	K0	Di	Adiv	Aatm	Agr	Afol	Ahous	Abar	Cmet	RL	Lr
	(m)	(m)	(m)			(Hz)	dB(A)	dB	dB	(dB)	(dB)	(dB)	(dB)	(dB)	(dB)	(dB)	(dB)	(dB)	(dB)	dB(A)
4518	340597.61	5028609.04	103.95	0	DEN	A	84.4	0.0	0.0	0.0	0.0	64.2	2.1	-1.5	0.0	0.0	5.4	0.0	0.0	14.3
4520	340597.61	5028609.04	103.95	1	DEN	A	84.4	0.0	0.0	0.0	0.0	64.7	2.1	-1.8	0.0	0.0	4.8	0.0	3.7	10.9

Point Source, ISO 9613, Name: "Medium Voltage Substation 040", ID: "I02!MVT040"																				
Nr.	X	Y	Z	Refl.	DEN	Freq.	Lw	l/a	Optime	K0	Di	Adiv	Aatm	Agr	Afol	Ahous	Abar	Cmet	RL	Lr
	(m)	(m)	(m)			(Hz)	dB(A)	dB	dB	(dB)	(dB)	(dB)	(dB)	(dB)	(dB)	(dB)	(dB)	(dB)	(dB)	dB(A)
4550	340446.81	5028619.42	103.20	0	DEN	A	84.5	0.0	0.0	0.0	0.0	64.3	1.5	-0.0	0.0	0.0	6.0	0.0	0.0	12.8
4564	340446.81	5028619.42	103.20	1	DEN	A	84.5	0.0	0.0	0.0	0.0	65.1	1.6	-1.4	0.0	0.0	6.2	0.0	8.8	4.2
4597	340446.81	5028619.42	103.20	1	DEN	A	84.5	0.0	0.0	0.0	0.0	64.5	1.5	-0.4	0.0	0.0	4.8	0.0	6.4	7.6

Point Source, ISO 9613, Name: "Battery Energy Storage System 034", ID: "I0000!BESS034"																				
Nr.	X	Y	Z	Refl.	DEN	Freq.	Lw	l/a	Optime	K0	Di	Adiv	Aatm	Agr	Afol	Ahous	Abar	Cmet	RL	Lr
	(m)	(m)	(m)			(Hz)	dB(A)	dB	dB	(dB)	(dB)	(dB)	(dB)	(dB)	(dB)	(dB)	(dB)	(dB)	(dB)	dB(A)
4603	340678.98	5028621.84	103.95	0	DEN	A	84.4	0.0	0.0	0.0	0.0	64.2	2.1	-1.2	0.0	0.0	10.2	0.0	0.0	9.1
4609	340678.98	5028621.84	103.95	1	DEN	A	84.4	0.0	0.0	0.0	0.0	65.0	2.2	-1.8	0.0	0.0	4.8	0.0	12.4	1.8

Point Source, ISO 9613, Name: "Battery Energy Storage System 027", ID: "I0001!BESS027"																				
Nr.	X	Y	Z	Refl.	DEN	Freq.	Lw	l/a	Optime	K0	Di	Adiv	Aatm	Agr	Afol	Ahous	Abar	Cmet	RL	Lr
	(m)	(m)	(m)			(Hz)	dB(A)	dB	dB	(dB)	(dB)	(dB)	(dB)	(dB)	(dB)	(dB)	(dB)	(dB)	(dB)	dB(A)
4625	340657.62	5028616.85	103.95	0	DEN	A	84.4	0.0	0.0	0.0	0.0	64.2	2.1	-1.4	0.0	0.0	5.5	0.0	0.0	14.0
4630	340657.62	5028616.85	103.95	1	DEN	A	84.4	0.0	0.0	0.0	0.0	64.7	2.1	-1.7	0.0	0.0	4.8	0.0	3.7	10.9

Point Source, ISO 9613, Name: "Medium Voltage Substation 023", ID: "I02!MVT023"																				
Nr.	X	Y	Z	Refl.	DEN	Freq.	Lw	l/a	Optime	K0	Di	Adiv	Aatm	Agr	Afol	Ahous	Abar	Cmet	RL	Lr
	(m)	(m)	(m)			(Hz)	dB(A)	dB	dB	(dB)	(dB)	(dB)	(dB)	(dB)	(dB)	(dB)	(dB)	(dB)	(dB)	dB(A)
4669	340547.68	5028603.73	103.20	0	DEN	A	84.5	0.0	0.0	0.0	0.0	64.3	1.5	-1.2	0.0	0.0	7.7	0.0	0.0	12.2

Point Source, ISO 9613, Name: "Battery Energy Storage System 165", ID: "I0006!BESS165"																				
Nr.	X	Y	Z	Refl.	DEN	Freq.	Lw	l/a	Optime	K0	Di	Adiv	Aatm	Agr	Afol	Ahous	Abar	Cmet	RL	Lr
	(m)	(m)	(m)			(Hz)	dB(A)	dB	dB	(dB)	(dB)	(dB)	(dB)	(dB)	(dB)	(dB)	(dB)	(dB)	(dB)	dB(A)
4714	340472.96	5028616.52	103.95	0	DEN	A	84.4	0.0	0.0	0.0	0.0	64.2	2.1	-1.7	0.0	0.0	10.5	0.0	0.0	9.4
4732	340472.96	5028616.52	103.95	1	DEN	A	84.4	0.0	0.0	0.0	0.0	65.4	2.3	-1.8	0.0	0.0	4.8	0.0	12.5	1.3

Point Source, ISO 9613, Name: "Battery Energy Storage System 162", ID: "I0006!BESS162"																				
Nr.	X	Y	Z	Refl.	DEN	Freq.	Lw	l/a	Optime	K0	Di	Adiv	Aatm	Agr	Afol	Ahous	Abar	Cmet	RL	Lr
	(m)	(m)	(m)			(Hz)	dB(A)	dB	dB	(dB)	(dB)	(dB)	(dB)	(dB)	(dB)	(dB)	(dB)	(dB)	(dB)	dB(A)
4763	340464.50	5028617.94	103.95	0	DEN	A	84.4	0.0	0.0	0.0	0.0	64.2	2.1	-1.6	0.0	0.0	8.0	0.0	0.0	11.8
4781	340464.50	5028617.94	103.95	1	DEN	A	84.4	0.0	0.0	0.0	0.0	65.3	2.3	-1.6	0.0	0.0	4.8	0.0	3.7	10.0

Point Source, ISO 9613, Name: "Medium Voltage Substation 009", ID: "I02!MVT009"																				
Nr.	X	Y	Z	Refl.	DEN	Freq.	Lw	l/a	Optime	K0	Di	Adiv	Aatm	Agr	Afol	Ahous	Abar	Cmet	RL	Lr
	(m)	(m)	(m)			(Hz)	dB(A)	dB	dB	(dB)	(dB)	(dB)	(dB)	(dB)	(dB)	(dB)	(dB)	(dB)	(dB)	dB(A)
4813	340675.31	5028615.37	103.20	0	DEN	A	84.5	0.0	0.0	0.0	0.0	64.3	1.5	-1.1	0.0	0.0	8.0	0.0	0.0	11.9
4824	340675.31	5028615.37	103.20	1	DEN	A	84.5	0.0	0.0	0.0	0.0	64.9	1.6	-1.5	0.0	0.0	6.3	0.0	8.8	4.4
4839	340675.31	5028615.37	103.20	1	DEN	A	84.5	0.0	0.0	0.0	0.0	64.5	1.5	-1.3	0.0	0.0	5.7	0.0	7.1	7.0

Point Source, ISO 9613, Name: "Battery Energy Storage System 090", ID: "I0004!BESS090"																				
Nr.	X	Y	Z	Refl.	DEN	Freq.	Lw	l/a	Optime	K0	Di	Adiv	Aatm	Agr	Afol	Ahous	Abar	Cmet	RL	Lr
	(m)	(m)	(m)			(Hz)	dB(A)	dB	dB	(dB)	(dB)	(dB)	(dB)	(dB)	(dB)	(dB)	(dB)	(dB)	(dB)	dB(A)
4849	340558.96	5028606.22	103.95	0	DEN	A	84.4	0.0	0.0	0.0	0.0	64.2	2.1	-1.5	0.0	0.0	7.6	0.0	0.0	12.0

Point Source, ISO 9613, Name: "Battery Energy Storage System 062", ID: "I0002!BESS062"																				
Nr.	X	Y	Z	Refl.	DEN	Freq.	Lw	l/a	Optime	K0	Di	Adiv	Aatm	Agr	Afol	Ahous	Abar	Cmet	RL	Lr
	(m)	(m)	(m)			(Hz)	dB(A)	dB	dB	(dB)	(dB)	(dB)	(dB)	(dB)	(dB)	(dB)	(dB)	(dB)	(dB)	dB(A)
4888	340625.98	5028610.06	103.95	0	DEN	A	84.4	0.0	0.0	0.0	0.0	64.2	2.1	-1.6	0.0	0.0	10.3	0.0	0.0	9.4
4889	340625.98	5028610.06	103.95	1	DEN	A	84.4	0.0	0.0	0.0	0.0	65.1	2.2	-1.9	0.0	0.0	4.8	0.0	12.4	1.7

Sample Calculation at POR3 - Regular Operations

Point Source, ISO 9613, Name: "Medium Voltage Substation 041", ID: "I02!MVT041"																				
Nr.	X	Y	Z	Ref.	DEN	Freq.	Lw	l/a	Optime	K0	Di	Adiv	Aatm	Agr	Afol	Ahous	Abar	Cmet	RL	Lr
	(m)	(m)	(m)			(Hz)	dB(A)	dB	dB	(dB)	(dB)	(dB)	(dB)	(dB)	(dB)	(dB)	(dB)	(dB)	(dB)	dB(A)
4927	340453.82	5028615.44	103.20	0	DEN	A	84.5	0.0	0.0	0.0	0.0	64.3	1.5	-0.9	0.0	0.0	6.5	0.0	0.0	13.1
4944	340453.82	5028615.44	103.20	1	DEN	A	84.5	0.0	0.0	0.0	0.0	65.1	1.6	-1.4	0.0	0.0	6.2	0.0	8.7	4.2
4974	340453.82	5028615.44	103.20	1	DEN	A	84.5	0.0	0.0	0.0	0.0	64.6	1.5	-0.8	0.0	0.0	5.1	0.0	6.4	7.8

Point Source, ISO 9613, Name: "Battery Energy Storage System 052", ID: "I0003!BESS052"																				
Nr.	X	Y	Z	Ref.	DEN	Freq.	Lw	l/a	Optime	K0	Di	Adiv	Aatm	Agr	Afol	Ahous	Abar	Cmet	RL	Lr
	(m)	(m)	(m)			(Hz)	dB(A)	dB	dB	(dB)	(dB)	(dB)	(dB)	(dB)	(dB)	(dB)	(dB)	(dB)	(dB)	dB(A)
4987	340596.16	5028606.48	103.95	0	DEN	A	84.4	0.0	0.0	0.0	0.0	64.3	2.1	-1.6	0.0	0.0	5.2	0.0	0.0	14.5
4989	340596.16	5028606.48	103.95	1	DEN	A	84.4	0.0	0.0	0.0	0.0	64.6	2.1	-1.7	0.0	0.0	4.8	0.0	2.6	12.0

Point Source, ISO 9613, Name: "Battery Energy Storage System 028", ID: "I0001!BESS028"																				
Nr.	X	Y	Z	Ref.	DEN	Freq.	Lw	l/a	Optime	K0	Di	Adiv	Aatm	Agr	Afol	Ahous	Abar	Cmet	RL	Lr
	(m)	(m)	(m)			(Hz)	dB(A)	dB	dB	(dB)	(dB)	(dB)	(dB)	(dB)	(dB)	(dB)	(dB)	(dB)	(dB)	dB(A)
5014	340656.17	5028614.29	103.95	0	DEN	A	84.4	0.0	0.0	0.0	0.0	64.3	2.1	-1.4	0.0	0.0	5.3	0.0	0.0	14.3
5016	340656.17	5028614.29	103.95	1	DEN	A	84.4	0.0	0.0	0.0	0.0	64.6	2.1	-1.7	0.0	0.0	4.8	0.0	3.7	10.9

Point Source, ISO 9613, Name: "Battery Energy Storage System 093", ID: "I0004!BESS093"																				
Nr.	X	Y	Z	Ref.	DEN	Freq.	Lw	l/a	Optime	K0	Di	Adiv	Aatm	Agr	Afol	Ahous	Abar	Cmet	RL	Lr
	(m)	(m)	(m)			(Hz)	dB(A)	dB	dB	(dB)	(dB)	(dB)	(dB)	(dB)	(dB)	(dB)	(dB)	(dB)	(dB)	dB(A)
5040	340567.42	5028604.80	103.95	0	DEN	A	84.4	0.0	0.0	0.0	0.0	64.3	2.1	-1.6	0.0	0.0	13.1	0.0	0.0	6.6

Point Source, ISO 9613, Name: "Battery Energy Storage System 169", ID: "I0006!BESS169"																				
Nr.	X	Y	Z	Ref.	DEN	Freq.	Lw	l/a	Optime	K0	Di	Adiv	Aatm	Agr	Afol	Ahous	Abar	Cmet	RL	Lr
	(m)	(m)	(m)			(Hz)	dB(A)	dB	dB	(dB)	(dB)	(dB)	(dB)	(dB)	(dB)	(dB)	(dB)	(dB)	(dB)	dB(A)
5083	340479.97	5028612.55	103.95	0	DEN	A	84.4	0.0	0.0	0.0	0.0	64.3	2.1	-1.8	0.0	0.0	10.4	0.0	0.0	9.4
5099	340479.97	5028612.55	103.95	1	DEN	A	84.4	0.0	0.0	0.0	0.0	65.4	2.3	-1.9	0.0	0.0	4.8	0.0	12.5	1.3

Point Source, ISO 9613, Name: "Medium Voltage Substation 016", ID: "I02!MVT016"																				
Nr.	X	Y	Z	Ref.	DEN	Freq.	Lw	l/a	Optime	K0	Di	Adiv	Aatm	Agr	Afol	Ahous	Abar	Cmet	RL	Lr
	(m)	(m)	(m)			(Hz)	dB(A)	dB	dB	(dB)	(dB)	(dB)	(dB)	(dB)	(dB)	(dB)	(dB)	(dB)	(dB)	dB(A)
5138	340622.31	5028603.59	103.20	0	DEN	A	84.5	0.0	0.0	0.0	0.0	64.4	1.5	-1.3	0.0	0.0	8.0	0.0	0.0	11.9
5139	340622.31	5028603.59	103.20	1	DEN	A	84.5	0.0	0.0	0.0	0.0	65.0	1.6	-1.6	0.0	0.0	5.9	0.0	8.4	5.2

Point Source, ISO 9613, Name: "Battery Energy Storage System 166", ID: "I0006!BESS166"																				
Nr.	X	Y	Z	Ref.	DEN	Freq.	Lw	l/a	Optime	K0	Di	Adiv	Aatm	Agr	Afol	Ahous	Abar	Cmet	RL	Lr
	(m)	(m)	(m)			(Hz)	dB(A)	dB	dB	(dB)	(dB)	(dB)	(dB)	(dB)	(dB)	(dB)	(dB)	(dB)	(dB)	dB(A)
5188	340471.51	5028613.96	103.95	0	DEN	A	84.4	0.0	0.0	0.0	0.0	64.3	2.1	-1.7	0.0	0.0	7.9	0.0	0.0	11.9
5198	340471.51	5028613.96	103.95	1	DEN	A	84.4	0.0	0.0	0.0	0.0	65.3	2.3	-1.7	0.0	0.0	4.8	0.0	3.7	10.1

Point Source, ISO 9613, Name: "Medium Voltage Substation 024", ID: "I02!MVT024"																				
Nr.	X	Y	Z	Ref.	DEN	Freq.	Lw	l/a	Optime	K0	Di	Adiv	Aatm	Agr	Afol	Ahous	Abar	Cmet	RL	Lr
	(m)	(m)	(m)			(Hz)	dB(A)	dB	dB	(dB)	(dB)	(dB)	(dB)	(dB)	(dB)	(dB)	(dB)	(dB)	(dB)	dB(A)
5236	340554.69	5028599.75	103.20	0	DEN	A	84.5	0.0	0.0	0.0	0.0	64.4	1.5	-1.4	0.0	0.0	6.2	0.0	0.0	13.8

Point Source, ISO 9613, Name: "Battery Energy Storage System 065", ID: "I0002!BESS065"																				
Nr.	X	Y	Z	Ref.	DEN	Freq.	Lw	l/a	Optime	K0	Di	Adiv	Aatm	Agr	Afol	Ahous	Abar	Cmet	RL	Lr
	(m)	(m)	(m)			(Hz)	dB(A)	dB	dB	(dB)	(dB)	(dB)	(dB)	(dB)	(dB)	(dB)	(dB)	(dB)	(dB)	dB(A)
5288	340634.44	5028608.64	103.95	0	DEN	A	84.4	0.0	0.0	0.0	0.0	64.3	2.1	-1.6	0.0	0.0	13.4	0.0	0.0	6.3
5289	340634.44	5028608.64	103.95	1	DEN	A	84.4	0.0	0.0	0.0	0.0	65.3	2.3	-1.9	0.0	0.0	4.8	0.0	12.5	1.5

Point Source, ISO 9613, Name: "Medium Voltage Substation 042", ID: "I02!MVT042"																				
Nr.	X	Y	Z	Ref.	DEN	Freq.	Lw	l/a	Optime	K0	Di	Adiv	Aatm	Agr	Afol	Ahous	Abar	Cmet	RL	Lr
	(m)	(m)	(m)			(Hz)	dB(A)	dB	dB	(dB)	(dB)	(dB)	(dB)	(dB)	(dB)	(dB)	(dB)	(dB)	(dB)	dB(A)
5334	340460.83	5028611.47	103.20	0	DEN	A	84.5	0.0	0.0	0.0	0.0	64.4	1.5	-1.0	0.0	0.0	6.5	0.0	0.0	13.1
5351	340460.83	5028611.47	103.20	1	DEN	A	84.5	0.0	0.0	0.0	0.0	65.2	1.6	-1.5	0.0	0.0	6.2	0.0	8.7	4.3
5380	340460.83	5028611.47	103.20	1	DEN	A	84.5	0.0	0.0	0.0	0.0	64.6	1.5	-0.9	0.0	0.0	5.1	0.0	6.3	7.9

Point Source, ISO 9613, Name: "Battery Energy Storage System 055", ID: "I0003!BESS055"																				
Nr.	X	Y	Z	Ref.	DEN	Freq.	Lw	l/a	Optime	K0	Di	Adiv	Aatm	Agr	Afol	Ahous	Abar	Cmet	RL	Lr
	(m)	(m)	(m)			(Hz)	dB(A)	dB	dB	(dB)	(dB)	(dB)	(dB)	(dB)	(dB)	(dB)	(dB)	(dB)	(dB)	dB(A)
5392	340604.62	5028605.06	103.95	0	DEN	A	84.4	0.0	0.0	0.0	0.0	64.3	2.1	-1.5	0.0	0.0	5.4	0.0	0.0	14.2
5393	340604.62	5028605.06	103.95	1	DEN	A	84.4	0.0	0.0	0.0	0.0	64.8	2.2	-1.8	0.0	0.0	4.8	0.0	3.7	10.8

Sample Calculation at POR3 - Regular Operations

Point Source, ISO 9613, Name: "Battery Energy Storage System 031", ID: "I0001!BESS031"																				
Nr.	X	Y	Z	Refl.	DEN	Freq.	Lw	l/a	Optime	K0	Di	Adiv	Aatm	Agr	Afol	Ahous	Abar	Cmet	RL	Lr
	(m)	(m)	(m)			(Hz)	dB(A)	dB	dB	(dB)	(dB)	(dB)	(dB)	(dB)	(dB)	(dB)	(dB)	(dB)	(dB)	dB(A)
5423	340664.63	5028612.87	103.95	0	DEN	A	84.4	0.0	0.0	0.0	0.0	64.3	2.1	-1.4	0.0	0.0	5.5	0.0	0.0	13.9
5431	340664.63	5028612.87	103.95	1	DEN	A	84.4	0.0	0.0	0.0	0.0	64.7	2.2	-1.8	0.0	0.0	4.8	0.0	3.7	10.8

Point Source, ISO 9613, Name: "Battery Energy Storage System 094", ID: "I0004!BESS094"																				
Nr.	X	Y	Z	Refl.	DEN	Freq.	Lw	l/a	Optime	K0	Di	Adiv	Aatm	Agr	Afol	Ahous	Abar	Cmet	RL	Lr
	(m)	(m)	(m)			(Hz)	dB(A)	dB	dB	(dB)	(dB)	(dB)	(dB)	(dB)	(dB)	(dB)	(dB)	(dB)	(dB)	dB(A)
5447	340565.97	5028602.25	103.95	0	DEN	A	84.4	0.0	0.0	0.0	0.0	64.3	2.1	-1.6	0.0	0.0	10.0	0.0	0.0	9.7

Point Source, ISO 9613, Name: "Battery Energy Storage System 143", ID: "I0007!BESS143"																				
Nr.	X	Y	Z	Refl.	DEN	Freq.	Lw	l/a	Optime	K0	Di	Adiv	Aatm	Agr	Afol	Ahous	Abar	Cmet	RL	Lr
	(m)	(m)	(m)			(Hz)	dB(A)	dB	dB	(dB)	(dB)	(dB)	(dB)	(dB)	(dB)	(dB)	(dB)	(dB)	(dB)	dB(A)
5492	340422.55	5028624.62	103.95	0	DEN	A	84.4	0.0	0.0	0.0	0.0	64.3	2.1	-0.9	0.0	0.0	2.2	0.0	0.0	16.7
5499	340422.55	5028624.62	103.95	1	DEN	A	84.4	0.0	0.0	0.0	0.0	64.9	2.2	-1.3	0.0	0.0	0.0	0.0	3.6	15.0

Point Source, ISO 9613, Name: "Battery Energy Storage System 173", ID: "I0006!BESS173"																				
Nr.	X	Y	Z	Refl.	DEN	Freq.	Lw	l/a	Optime	K0	Di	Adiv	Aatm	Agr	Afol	Ahous	Abar	Cmet	RL	Lr
	(m)	(m)	(m)			(Hz)	dB(A)	dB	dB	(dB)	(dB)	(dB)	(dB)	(dB)	(dB)	(dB)	(dB)	(dB)	(dB)	dB(A)
5522	340486.98	5028608.57	103.95	0	DEN	A	84.4	0.0	0.0	0.0	0.0	64.3	2.1	-1.9	0.0	0.0	10.4	0.0	0.0	9.5
5534	340486.98	5028608.57	103.95	1	DEN	A	84.4	0.0	0.0	0.0	0.0	65.4	2.3	-2.0	0.0	0.0	4.8	0.0	12.5	1.4

Point Source, ISO 9613, Name: "Battery Energy Storage System 170", ID: "I0006!BESS170"																				
Nr.	X	Y	Z	Refl.	DEN	Freq.	Lw	l/a	Optime	K0	Di	Adiv	Aatm	Agr	Afol	Ahous	Abar	Cmet	RL	Lr
	(m)	(m)	(m)			(Hz)	dB(A)	dB	dB	(dB)	(dB)	(dB)	(dB)	(dB)	(dB)	(dB)	(dB)	(dB)	(dB)	dB(A)
5571	340478.52	5028609.99	103.95	0	DEN	A	84.4	0.0	0.0	0.0	0.0	64.3	2.1	-1.8	0.0	0.0	7.9	0.0	0.0	11.9
5584	340478.52	5028609.99	103.95	1	DEN	A	84.4	0.0	0.0	0.0	0.0	65.3	2.3	-1.8	0.0	0.0	4.8	0.0	3.7	10.1

Point Source, ISO 9613, Name: "Battery Energy Storage System 066", ID: "I0002!BESS066"																				
Nr.	X	Y	Z	Refl.	DEN	Freq.	Lw	l/a	Optime	K0	Di	Adiv	Aatm	Agr	Afol	Ahous	Abar	Cmet	RL	Lr
	(m)	(m)	(m)			(Hz)	dB(A)	dB	dB	(dB)	(dB)	(dB)	(dB)	(dB)	(dB)	(dB)	(dB)	(dB)	(dB)	dB(A)
5620	340632.99	5028606.08	103.95	0	DEN	A	84.4	0.0	0.0	0.0	0.0	64.3	2.1	-1.7	0.0	0.0	10.3	0.0	0.0	9.4
5622	340632.99	5028606.08	103.95	1	DEN	A	84.4	0.0	0.0	0.0	0.0	65.2	2.2	-1.9	0.0	0.0	4.8	0.0	12.5	1.6

Point Source, ISO 9613, Name: "Medium Voltage Substation 043", ID: "I02!MVT043"																				
Nr.	X	Y	Z	Refl.	DEN	Freq.	Lw	l/a	Optime	K0	Di	Adiv	Aatm	Agr	Afol	Ahous	Abar	Cmet	RL	Lr
	(m)	(m)	(m)			(Hz)	dB(A)	dB	dB	(dB)	(dB)	(dB)	(dB)	(dB)	(dB)	(dB)	(dB)	(dB)	(dB)	dB(A)
5649	340467.84	5028607.49	103.20	0	DEN	A	84.5	0.0	0.0	0.0	0.0	64.4	1.5	-1.1	0.0	0.0	6.5	0.0	0.0	13.2
5668	340467.84	5028607.49	103.20	1	DEN	A	84.5	0.0	0.0	0.0	0.0	65.2	1.6	-1.5	0.0	0.0	6.2	0.0	8.7	4.4
5693	340467.84	5028607.49	103.20	1	DEN	A	84.5	0.0	0.0	0.0	0.0	64.6	1.5	-1.0	0.0	0.0	5.1	0.0	6.3	8.0

Point Source, ISO 9613, Name: "Battery Energy Storage System 056", ID: "I0003!BESS056"																				
Nr.	X	Y	Z	Refl.	DEN	Freq.	Lw	l/a	Optime	K0	Di	Adiv	Aatm	Agr	Afol	Ahous	Abar	Cmet	RL	Lr
	(m)	(m)	(m)			(Hz)	dB(A)	dB	dB	(dB)	(dB)	(dB)	(dB)	(dB)	(dB)	(dB)	(dB)	(dB)	(dB)	dB(A)
5709	340603.17	5028602.51	103.95	0	DEN	A	84.4	0.0	0.0	0.0	0.0	64.3	2.1	-1.6	0.0	0.0	5.2	0.0	0.0	14.4
5710	340603.17	5028602.51	103.95	1	DEN	A	84.4	0.0	0.0	0.0	0.0	64.7	2.1	-1.8	0.0	0.0	4.8	0.0	2.6	11.9

Point Source, ISO 9613, Name: "Battery Energy Storage System 097", ID: "I0004!BESS097"																				
Nr.	X	Y	Z	Refl.	DEN	Freq.	Lw	l/a	Optime	K0	Di	Adiv	Aatm	Agr	Afol	Ahous	Abar	Cmet	RL	Lr
	(m)	(m)	(m)			(Hz)	dB(A)	dB	dB	(dB)	(dB)	(dB)	(dB)	(dB)	(dB)	(dB)	(dB)	(dB)	(dB)	dB(A)
5731	340574.43	5028600.83	103.95	0	DEN	A	84.4	0.0	0.0	0.0	0.0	64.3	2.1	-1.7	0.0	0.0	13.2	0.0	0.0	6.5

Point Source, ISO 9613, Name: "Battery Energy Storage System 147", ID: "I0007!BESS147"																				
Nr.	X	Y	Z	Refl.	DEN	Freq.	Lw	l/a	Optime	K0	Di	Adiv	Aatm	Agr	Afol	Ahous	Abar	Cmet	RL	Lr
	(m)	(m)	(m)			(Hz)	dB(A)	dB	dB	(dB)	(dB)	(dB)	(dB)	(dB)	(dB)	(dB)	(dB)	(dB)	(dB)	dB(A)
5765	340429.56	5028620.65	103.95	0	DEN	A	84.4	0.0	0.0	0.0	0.0	64.4	2.1	-0.9	0.0	0.0	4.6	0.0	0.0	14.3
5775	340429.56	5028620.65	103.95	1	DEN	A	84.4	0.0	0.0	0.0	0.0	64.9	2.2	-1.4	0.0	0.0	4.7	0.0	3.7	10.3

Point Source, ISO 9613, Name: "Battery Energy Storage System 032", ID: "I0001!BESS032"																				
Nr.	X	Y	Z	Refl.	DEN	Freq.	Lw	l/a	Optime	K0	Di	Adiv	Aatm	Agr	Afol	Ahous	Abar	Cmet	RL	Lr
	(m)	(m)	(m)			(Hz)	dB(A)	dB	dB	(dB)	(dB)	(dB)	(dB)	(dB)	(dB)	(dB)	(dB)	(dB)	(dB)	dB(A)
5805	340663.18	5028610.32	103.95	0	DEN	A	84.4	0.0	0.0	0.0	0.0	64.4	2.1	-1.5	0.0	0.0	5.3	0.0	0.0	14.2
5812	340663.18	5028610.32	103.95	1	DEN	A	84.4	0.0	0.0	0.0	0.0	64.7	2.1	-1.7	0.0	0.0	4.8	0.0	3.7	10.8

Sample Calculation at POR3 - Regular Operations

Point Source, ISO 9613, Name: "Medium Voltage Substation 025", ID: "I02!MVT025"																				
Nr.	X	Y	Z	Refl.	DEN	Freq.	Lw	l/a	Optime	K0	Di	Adiv	Aatm	Agr	Afol	Ahous	Abar	Cmet	RL	Lr
	(m)	(m)	(m)			(Hz)	dB(A)	dB	dB	(dB)	(dB)	(dB)	(dB)	(dB)	(dB)	(dB)	(dB)	(dB)	(dB)	dB(A)
5829	340561.70	5028595.78	103.20	0	DEN	A	84.5	0.0	0.0	0.0	0.0	64.4	1.5	-1.3	0.0	0.0	6.1	0.0	0.0	13.7
5854	340561.70	5028595.78	103.20	1	DEN	A	84.5	0.0	0.0	0.0	0.0	64.7	1.5	-1.5	0.0	0.0	6.1	0.0	7.6	6.1

Point Source, ISO 9613, Name: "Medium Voltage Substation 017", ID: "I02!MVT017"																				
Nr.	X	Y	Z	Refl.	DEN	Freq.	Lw	l/a	Optime	K0	Di	Adiv	Aatm	Agr	Afol	Ahous	Abar	Cmet	RL	Lr
	(m)	(m)	(m)			(Hz)	dB(A)	dB	dB	(dB)	(dB)	(dB)	(dB)	(dB)	(dB)	(dB)	(dB)	(dB)	(dB)	dB(A)
5875	340629.32	5028599.61	103.20	0	DEN	A	84.5	0.0	0.0	0.0	0.0	64.4	1.5	-1.5	0.0	0.0	8.0	0.0	0.0	12.1
5877	340629.32	5028599.61	103.20	1	DEN	A	84.5	0.0	0.0	0.0	0.0	65.1	1.6	-1.6	0.0	0.0	5.9	0.0	8.4	5.0

Point Source, ISO 9613, Name: "Battery Energy Storage System 174", ID: "I0006!BESS174"																				
Nr.	X	Y	Z	Refl.	DEN	Freq.	Lw	l/a	Optime	K0	Di	Adiv	Aatm	Agr	Afol	Ahous	Abar	Cmet	RL	Lr
	(m)	(m)	(m)			(Hz)	dB(A)	dB	dB	(dB)	(dB)	(dB)	(dB)	(dB)	(dB)	(dB)	(dB)	(dB)	(dB)	dB(A)
5912	340485.53	5028606.01	103.95	0	DEN	A	84.4	0.0	0.0	0.0	0.0	64.4	2.1	-1.9	0.0	0.0	7.9	0.0	0.0	12.0
5925	340485.53	5028606.01	103.95	1	DEN	A	84.4	0.0	0.0	0.0	0.0	65.4	2.3	-1.9	0.0	0.0	4.8	0.0	3.7	10.2

Point Source, ISO 9613, Name: "Battery Energy Storage System 177", ID: "I0006!BESS177"																				
Nr.	X	Y	Z	Refl.	DEN	Freq.	Lw	l/a	Optime	K0	Di	Adiv	Aatm	Agr	Afol	Ahous	Abar	Cmet	RL	Lr
	(m)	(m)	(m)			(Hz)	dB(A)	dB	dB	(dB)	(dB)	(dB)	(dB)	(dB)	(dB)	(dB)	(dB)	(dB)	(dB)	dB(A)
5962	340493.99	5028604.60	103.95	0	DEN	A	84.4	0.0	0.0	0.0	0.0	64.4	2.1	-1.9	0.0	0.0	10.4	0.0	0.0	9.5
5979	340493.99	5028604.60	103.95	1	DEN	A	84.4	0.0	0.0	0.0	0.0	65.5	2.3	-2.1	0.0	0.0	4.8	0.0	12.6	1.4

Point Source, ISO 9613, Name: "Battery Energy Storage System 144", ID: "I0007!BESS144"																				
Nr.	X	Y	Z	Refl.	DEN	Freq.	Lw	l/a	Optime	K0	Di	Adiv	Aatm	Agr	Afol	Ahous	Abar	Cmet	RL	Lr
	(m)	(m)	(m)			(Hz)	dB(A)	dB	dB	(dB)	(dB)	(dB)	(dB)	(dB)	(dB)	(dB)	(dB)	(dB)	(dB)	dB(A)
6012	340421.10	5028622.07	103.95	0	DEN	A	84.4	0.0	0.0	0.0	0.0	64.4	2.1	-1.0	0.0	0.0	1.8	0.0	0.0	17.1
6018	340421.10	5028622.07	103.95	1	DEN	A	84.4	0.0	0.0	0.0	0.0	64.8	2.2	-1.3	0.0	0.0	0.0	0.0	2.5	16.1

Point Source, ISO 9613, Name: "Battery Energy Storage System 059", ID: "I0003!BESS059"																				
Nr.	X	Y	Z	Refl.	DEN	Freq.	Lw	l/a	Optime	K0	Di	Adiv	Aatm	Agr	Afol	Ahous	Abar	Cmet	RL	Lr
	(m)	(m)	(m)			(Hz)	dB(A)	dB	dB	(dB)	(dB)	(dB)	(dB)	(dB)	(dB)	(dB)	(dB)	(dB)	(dB)	dB(A)
6033	340611.63	5028601.09	103.95	0	DEN	A	84.4	0.0	0.0	0.0	0.0	64.4	2.1	-1.6	0.0	0.0	5.4	0.0	0.0	14.1
6035	340611.63	5028601.09	103.95	1	DEN	A	84.4	0.0	0.0	0.0	0.0	64.8	2.2	-1.8	0.0	0.0	4.8	0.0	3.7	10.7

Point Source, ISO 9613, Name: "Medium Voltage Substation 044", ID: "I02!MVT044"																				
Nr.	X	Y	Z	Refl.	DEN	Freq.	Lw	l/a	Optime	K0	Di	Adiv	Aatm	Agr	Afol	Ahous	Abar	Cmet	RL	Lr
	(m)	(m)	(m)			(Hz)	dB(A)	dB	dB	(dB)	(dB)	(dB)	(dB)	(dB)	(dB)	(dB)	(dB)	(dB)	(dB)	dB(A)
6070	340474.85	5028603.52	103.20	0	DEN	A	84.5	0.0	0.0	0.0	0.0	64.5	1.5	-1.2	0.0	0.0	6.5	0.0	0.0	13.2
6089	340474.85	5028603.52	103.20	1	DEN	A	84.5	0.0	0.0	0.0	0.0	65.2	1.6	-1.6	0.0	0.0	6.2	0.0	8.7	4.5
6113	340474.85	5028603.52	103.20	1	DEN	A	84.5	0.0	0.0	0.0	0.0	64.7	1.5	-1.1	0.0	0.0	5.1	0.0	6.2	8.0

Point Source, ISO 9613, Name: "Battery Energy Storage System 069", ID: "I0002!BESS069"																				
Nr.	X	Y	Z	Refl.	DEN	Freq.	Lw	l/a	Optime	K0	Di	Adiv	Aatm	Agr	Afol	Ahous	Abar	Cmet	RL	Lr
	(m)	(m)	(m)			(Hz)	dB(A)	dB	dB	(dB)	(dB)	(dB)	(dB)	(dB)	(dB)	(dB)	(dB)	(dB)	(dB)	dB(A)
6135	340641.45	5028604.66	103.95	0	DEN	A	84.4	0.0	0.0	0.0	0.0	64.4	2.1	-1.6	0.0	0.0	13.3	0.0	0.0	6.3
6136	340641.45	5028604.66	103.95	1	DEN	A	84.4	0.0	0.0	0.0	0.0	65.3	2.3	-1.9	0.0	0.0	4.8	0.0	12.5	1.4

Point Source, ISO 9613, Name: "Battery Energy Storage System 151", ID: "I0007!BESS151"																				
Nr.	X	Y	Z	Refl.	DEN	Freq.	Lw	l/a	Optime	K0	Di	Adiv	Aatm	Agr	Afol	Ahous	Abar	Cmet	RL	Lr
	(m)	(m)	(m)			(Hz)	dB(A)	dB	dB	(dB)	(dB)	(dB)	(dB)	(dB)	(dB)	(dB)	(dB)	(dB)	(dB)	dB(A)
6166	340436.57	5028616.67	103.95	0	DEN	A	84.4	0.0	0.0	0.0	0.0	64.4	2.1	-0.9	0.0	0.0	4.9	0.0	0.0	14.0
6179	340436.57	5028616.67	103.95	1	DEN	A	84.4	0.0	0.0	0.0	0.0	64.9	2.2	-1.4	0.0	0.0	4.8	0.0	3.7	10.2

Point Source, ISO 9613, Name: "Battery Energy Storage System 098", ID: "I0004!BESS098"																				
Nr.	X	Y	Z	Refl.	DEN	Freq.	Lw	l/a	Optime	K0	Di	Adiv	Aatm	Agr	Afol	Ahous	Abar	Cmet	RL	Lr
	(m)	(m)	(m)			(Hz)	dB(A)	dB	dB	(dB)	(dB)	(dB)	(dB)	(dB)	(dB)	(dB)	(dB)	(dB)	(dB)	dB(A)
6199	340572.98	5028598.27	103.95	0	DEN	A	84.4	0.0	0.0	0.0	0.0	64.4	2.1	-1.7	0.0	0.0	10.1	0.0	0.0	9.5

Point Source, ISO 9613, Name: "Battery Energy Storage System 148", ID: "I0007!BESS148"																				
Nr.	X	Y	Z	Refl.	DEN	Freq.	Lw	l/a	Optime	K0	Di	Adiv	Aatm	Agr	Afol	Ahous	Abar	Cmet	RL	Lr
	(m)	(m)	(m)			(Hz)	dB(A)	dB	dB	(dB)	(dB)	(dB)	(dB)	(dB)	(dB)	(dB)	(dB)	(dB)	(dB)	dB(A)
6231	340428.11	5028618.09	103.95	0	DEN	A	84.4	0.0	0.0	0.0	0.0	64.4	2.1	-1.0	0.0	0.0	4.5	0.0	0.0	14.4
6238	340428.11	5028618.09	103.95	1	DEN	A	84.4	0.0	0.0	0.0	0.0	64.9	2.2	-1.3	0.0	0.0	4.7	0.0	2.6	11.4

Sample Calculation at POR3 - Regular Operations

Point Source, ISO 9613, Name: "Battery Energy Storage System 035", ID: "I0001!BESS035"																				
Nr.	X	Y	Z	Refl.	DEN	Freq.	Lw	l/a	Optime	K0	Di	Adiv	Aatm	Agr	Afol	Ahous	Abar	Cmet	RL	Lr
	(m)	(m)	(m)			(Hz)	dB(A)	dB	dB	(dB)	(dB)	(dB)	(dB)	(dB)	(dB)	(dB)	(dB)	(dB)	(dB)	dB(A)
6258	340671.64	5028608.90	103.95	0	DEN	A	84.4	0.0	0.0	0.0	0.0	64.4	2.1	-1.4	0.0	0.0	5.5	0.0	0.0	13.8
6264	340671.64	5028608.90	103.95	1	DEN	A	84.4	0.0	0.0	0.0	0.0	64.8	2.2	-1.8	0.0	0.0	4.8	0.0	3.7	10.7

Point Source, ISO 9613, Name: "Battery Energy Storage System 087", ID: "I0005!BESS087"																				
Nr.	X	Y	Z	Refl.	DEN	Freq.	Lw	l/a	Optime	K0	Di	Adiv	Aatm	Agr	Afol	Ahous	Abar	Cmet	RL	Lr
	(m)	(m)	(m)			(Hz)	dB(A)	dB	dB	(dB)	(dB)	(dB)	(dB)	(dB)	(dB)	(dB)	(dB)	(dB)	(dB)	dB(A)
6284	340544.62	5028597.25	103.95	0	DEN	A	84.4	0.0	0.0	0.0	0.0	64.4	2.1	-1.5	0.0	0.0	6.1	0.0	0.0	13.3
6288	340544.62	5028597.25	103.95	1	DEN	A	84.4	0.0	0.0	0.0	0.0	66.0	2.4	-2.2	0.0	0.0	4.8	0.0	12.8	0.7

Point Source, ISO 9613, Name: "Battery Energy Storage System 101", ID: "I0004!BESS101"																				
Nr.	X	Y	Z	Refl.	DEN	Freq.	Lw	l/a	Optime	K0	Di	Adiv	Aatm	Agr	Afol	Ahous	Abar	Cmet	RL	Lr
	(m)	(m)	(m)			(Hz)	dB(A)	dB	dB	(dB)	(dB)	(dB)	(dB)	(dB)	(dB)	(dB)	(dB)	(dB)	(dB)	dB(A)
6322	340581.44	5028596.85	103.95	0	DEN	A	84.4	0.0	0.0	0.0	0.0	64.4	2.1	-1.7	0.0	0.0	13.2	0.0	0.0	6.4

Point Source, ISO 9613, Name: "Battery Energy Storage System 155", ID: "I0007!BESS155"																				
Nr.	X	Y	Z	Refl.	DEN	Freq.	Lw	l/a	Optime	K0	Di	Adiv	Aatm	Agr	Afol	Ahous	Abar	Cmet	RL	Lr
	(m)	(m)	(m)			(Hz)	dB(A)	dB	dB	(dB)	(dB)	(dB)	(dB)	(dB)	(dB)	(dB)	(dB)	(dB)	(dB)	dB(A)
6353	340443.14	5028612.95	103.95	0	DEN	A	84.4	0.0	0.0	0.0	0.0	64.4	2.1	-0.9	0.0	0.0	4.9	0.0	0.0	13.9
6363	340443.14	5028612.95	103.95	1	DEN	A	84.4	0.0	0.0	0.0	0.0	65.0	2.2	-1.4	0.0	0.0	4.7	0.0	3.7	10.2

Point Source, ISO 9613, Name: "Battery Energy Storage System 060", ID: "I0003!BESS060"																				
Nr.	X	Y	Z	Refl.	DEN	Freq.	Lw	l/a	Optime	K0	Di	Adiv	Aatm	Agr	Afol	Ahous	Abar	Cmet	RL	Lr
	(m)	(m)	(m)			(Hz)	dB(A)	dB	dB	(dB)	(dB)	(dB)	(dB)	(dB)	(dB)	(dB)	(dB)	(dB)	(dB)	dB(A)
6391	340610.18	5028598.53	103.95	0	DEN	A	84.4	0.0	0.0	0.0	0.0	64.4	2.1	-1.6	0.0	0.0	5.2	0.0	0.0	14.3
6392	340610.18	5028598.53	103.95	1	DEN	A	84.4	0.0	0.0	0.0	0.0	64.8	2.2	-1.8	0.0	0.0	4.8	0.0	2.6	11.8

Point Source, ISO 9613, Name: "Battery Energy Storage System 070", ID: "I0002!BESS070"																				
Nr.	X	Y	Z	Refl.	DEN	Freq.	Lw	l/a	Optime	K0	Di	Adiv	Aatm	Agr	Afol	Ahous	Abar	Cmet	RL	Lr
	(m)	(m)	(m)			(Hz)	dB(A)	dB	dB	(dB)	(dB)	(dB)	(dB)	(dB)	(dB)	(dB)	(dB)	(dB)	(dB)	dB(A)
6415	340640.00	5028602.11	103.95	0	DEN	A	84.4	0.0	0.0	0.0	0.0	64.4	2.1	-1.7	0.0	0.0	10.3	0.0	0.0	9.3
6416	340640.00	5028602.11	103.95	1	DEN	A	84.4	0.0	0.0	0.0	0.0	65.3	2.3	-1.9	0.0	0.0	4.8	0.0	12.5	1.5

Point Source, ISO 9613, Name: "Battery Energy Storage System 178", ID: "I0006!BESS178"																				
Nr.	X	Y	Z	Refl.	DEN	Freq.	Lw	l/a	Optime	K0	Di	Adiv	Aatm	Agr	Afol	Ahous	Abar	Cmet	RL	Lr
	(m)	(m)	(m)			(Hz)	dB(A)	dB	dB	(dB)	(dB)	(dB)	(dB)	(dB)	(dB)	(dB)	(dB)	(dB)	(dB)	dB(A)
6449	340492.54	5028602.04	103.95	0	DEN	A	84.4	0.0	0.0	0.0	0.0	64.4	2.1	-1.9	0.0	0.0	7.9	0.0	0.0	11.9
6464	340492.54	5028602.04	103.95	1	DEN	A	84.4	0.0	0.0	0.0	0.0	65.4	2.3	-2.0	0.0	0.0	4.8	0.0	12.5	1.4

Point Source, ISO 9613, Name: "Medium Voltage Substation 045", ID: "I02!MVT045"																				
Nr.	X	Y	Z	Refl.	DEN	Freq.	Lw	l/a	Optime	K0	Di	Adiv	Aatm	Agr	Afol	Ahous	Abar	Cmet	RL	Lr
	(m)	(m)	(m)			(Hz)	dB(A)	dB	dB	(dB)	(dB)	(dB)	(dB)	(dB)	(dB)	(dB)	(dB)	(dB)	(dB)	dB(A)
6502	340481.86	5028599.54	103.20	0	DEN	A	84.5	0.0	0.0	0.0	0.0	64.5	1.5	-1.3	0.0	0.0	6.4	0.0	0.0	13.3
6520	340481.86	5028599.54	103.20	1	DEN	A	84.5	0.0	0.0	0.0	0.0	65.3	1.6	-1.7	0.0	0.0	6.1	0.0	8.7	4.5
6522	340481.86	5028599.54	103.20	2	DEN	A	84.5	0.0	0.0	0.0	0.0	65.5	1.6	-1.8	0.0	0.0	4.9	0.0	14.2	0.0
6542	340481.86	5028599.54	103.20	1	DEN	A	84.5	0.0	0.0	0.0	0.0	64.7	1.5	-1.2	0.0	0.0	5.1	0.0	6.2	8.1

Point Source, ISO 9613, Name: "Battery Energy Storage System 181", ID: "I0006!BESS181"																				
Nr.	X	Y	Z	Refl.	DEN	Freq.	Lw	l/a	Optime	K0	Di	Adiv	Aatm	Agr	Afol	Ahous	Abar	Cmet	RL	Lr
	(m)	(m)	(m)			(Hz)	dB(A)	dB	dB	(dB)	(dB)	(dB)	(dB)	(dB)	(dB)	(dB)	(dB)	(dB)	(dB)	dB(A)
6555	340501.00	5028600.63	103.95	0	DEN	A	84.4	0.0	0.0	0.0	0.0	64.4	2.1	-1.9	0.0	0.0	10.3	0.0	0.0	9.5
6565	340501.00	5028600.63	103.95	1	DEN	A	84.4	0.0	0.0	0.0	0.0	65.5	2.3	-2.2	0.0	0.0	4.8	0.0	12.6	1.4

Point Source, ISO 9613, Name: "Medium Voltage Substation 026", ID: "I02!MVT026"																				
Nr.	X	Y	Z	Refl.	DEN	Freq.	Lw	l/a	Optime	K0	Di	Adiv	Aatm	Agr	Afol	Ahous	Abar	Cmet	RL	Lr
	(m)	(m)	(m)			(Hz)	dB(A)	dB	dB	(dB)	(dB)	(dB)	(dB)	(dB)	(dB)	(dB)	(dB)	(dB)	(dB)	dB(A)
6596	340568.71	5028591.80	103.20	0	DEN	A	84.5	0.0	0.0	0.0	0.0	64.5	1.5	-1.5	0.0	0.0	7.6	0.0	0.0	12.3

Point Source, ISO 9613, Name: "Battery Energy Storage System 152", ID: "I0007!BESS152"																				
Nr.	X	Y	Z	Refl.	DEN	Freq.	Lw	l/a	Optime	K0	Di	Adiv	Aatm	Agr	Afol	Ahous	Abar	Cmet	RL	Lr
	(m)	(m)	(m)			(Hz)	dB(A)	dB	dB	(dB)	(dB)	(dB)	(dB)	(dB)	(dB)	(dB)	(dB)	(dB)	(dB)	dB(A)
6636	340435.12	5028614.12	103.95	0	DEN	A	84.4	0.0	0.0	0.0	0.0	64.4	2.1	-1.0	0.0	0.0	4.8	0.0	0.0	14.0
6648	340435.12	5028614.12	103.95	1	DEN	A	84.4	0.0	0.0	0.0	0.0	64.9	2.2	-1.3	0.0	0.0	4.7	0.0	2.6	11.4

Sample Calculation at POR3 - Regular Operations

Point Source, ISO 9613, Name: "Battery Energy Storage System 036", ID: "I0001!BESS036"																				
Nr.	X	Y	Z	Refl.	DEN	Freq.	Lw	l/a	Optime	K0	Di	Adiv	Aatm	Agr	Afol	Ahous	Abar	Cmet	RL	Lr
	(m)	(m)	(m)			(Hz)	dB(A)	dB	dB	(dB)	(dB)	(dB)	(dB)	(dB)	(dB)	(dB)	(dB)	(dB)	(dB)	dB(A)
6662	340670.19	5028606.34	103.95	0	DEN	A	84.4	0.0	0.0	0.0	0.0	64.5	2.1	-1.5	0.0	0.0	5.3	0.0	0.0	14.0
6667	340670.19	5028606.34	103.95	1	DEN	A	84.4	0.0	0.0	0.0	0.0	64.8	2.2	-1.7	0.0	0.0	4.8	0.0	3.7	10.7

Point Source, ISO 9613, Name: "Medium Voltage Substation 018", ID: "I02!MVT018"																				
Nr.	X	Y	Z	Refl.	DEN	Freq.	Lw	l/a	Optime	K0	Di	Adiv	Aatm	Agr	Afol	Ahous	Abar	Cmet	RL	Lr
	(m)	(m)	(m)			(Hz)	dB(A)	dB	dB	(dB)	(dB)	(dB)	(dB)	(dB)	(dB)	(dB)	(dB)	(dB)	(dB)	dB(A)
6685	340636.33	5028595.64	103.20	0	DEN	A	84.5	0.0	0.0	0.0	0.0	64.5	1.5	-1.5	0.0	0.0	8.0	0.0	0.0	11.9
6687	340636.33	5028595.64	103.20	1	DEN	A	84.5	0.0	0.0	0.0	0.0	65.2	1.6	-1.6	0.0	0.0	6.0	0.0	8.5	4.9

Point Source, ISO 9613, Name: "Battery Energy Storage System 159", ID: "I0007!BESS159"																				
Nr.	X	Y	Z	Refl.	DEN	Freq.	Lw	l/a	Optime	K0	Di	Adiv	Aatm	Agr	Afol	Ahous	Abar	Cmet	RL	Lr
	(m)	(m)	(m)			(Hz)	dB(A)	dB	dB	(dB)	(dB)	(dB)	(dB)	(dB)	(dB)	(dB)	(dB)	(dB)	(dB)	dB(A)
6724	340450.15	5028608.97	103.95	0	DEN	A	84.4	0.0	0.0	0.0	0.0	64.5	2.1	-1.3	0.0	0.0	4.9	0.0	0.0	14.2
6731	340450.15	5028608.97	103.95	1	DEN	A	84.4	0.0	0.0	0.0	0.0	65.0	2.2	-1.4	0.0	0.0	4.7	0.0	3.7	10.1

Point Source, ISO 9613, Name: "Battery Energy Storage System 063", ID: "I0003!BESS063"																				
Nr.	X	Y	Z	Refl.	DEN	Freq.	Lw	l/a	Optime	K0	Di	Adiv	Aatm	Agr	Afol	Ahous	Abar	Cmet	RL	Lr
	(m)	(m)	(m)			(Hz)	dB(A)	dB	dB	(dB)	(dB)	(dB)	(dB)	(dB)	(dB)	(dB)	(dB)	(dB)	(dB)	dB(A)
6755	340618.64	5028597.12	103.95	0	DEN	A	84.4	0.0	0.0	0.0	0.0	64.5	2.1	-1.6	0.0	0.0	5.4	0.0	0.0	14.1
6756	340618.64	5028597.12	103.95	1	DEN	A	84.4	0.0	0.0	0.0	0.0	64.9	2.2	-1.8	0.0	0.0	4.8	0.0	3.7	10.6

Point Source, ISO 9613, Name: "Battery Energy Storage System 088", ID: "I0005!BESS088"																				
Nr.	X	Y	Z	Refl.	DEN	Freq.	Lw	l/a	Optime	K0	Di	Adiv	Aatm	Agr	Afol	Ahous	Abar	Cmet	RL	Lr
	(m)	(m)	(m)			(Hz)	dB(A)	dB	dB	(dB)	(dB)	(dB)	(dB)	(dB)	(dB)	(dB)	(dB)	(dB)	(dB)	dB(A)
6779	340543.17	5028594.70	103.95	0	DEN	A	84.4	0.0	0.0	0.0	0.0	64.5	2.1	-1.5	0.0	0.0	6.0	0.0	0.0	13.3
6787	340543.17	5028594.70	103.95	1	DEN	A	84.4	0.0	0.0	0.0	0.0	66.0	2.4	-2.2	0.0	0.0	4.8	0.0	12.8	0.7

Point Source, ISO 9613, Name: "Battery Energy Storage System 102", ID: "I0004!BESS102"																				
Nr.	X	Y	Z	Refl.	DEN	Freq.	Lw	l/a	Optime	K0	Di	Adiv	Aatm	Agr	Afol	Ahous	Abar	Cmet	RL	Lr
	(m)	(m)	(m)			(Hz)	dB(A)	dB	dB	(dB)	(dB)	(dB)	(dB)	(dB)	(dB)	(dB)	(dB)	(dB)	(dB)	dB(A)
6812	340579.99	5028594.30	103.95	0	DEN	A	84.4	0.0	0.0	0.0	0.0	64.5	2.1	-1.7	0.0	0.0	10.0	0.0	0.0	9.5

Point Source, ISO 9613, Name: "Battery Energy Storage System 156", ID: "I0007!BESS156"																				
Nr.	X	Y	Z	Refl.	DEN	Freq.	Lw	l/a	Optime	K0	Di	Adiv	Aatm	Agr	Afol	Ahous	Abar	Cmet	RL	Lr
	(m)	(m)	(m)			(Hz)	dB(A)	dB	dB	(dB)	(dB)	(dB)	(dB)	(dB)	(dB)	(dB)	(dB)	(dB)	(dB)	dB(A)
6837	340441.69	5028610.39	103.95	0	DEN	A	84.4	0.0	0.0	0.0	0.0	64.5	2.1	-1.0	0.0	0.0	4.8	0.0	0.0	14.0
6844	340441.69	5028610.39	103.95	1	DEN	A	84.4	0.0	0.0	0.0	0.0	64.9	2.2	-1.3	0.0	0.0	4.7	0.0	2.6	11.3

Point Source, ISO 9613, Name: "Medium Voltage Substation 046", ID: "I02!MVT046"																				
Nr.	X	Y	Z	Refl.	DEN	Freq.	Lw	l/a	Optime	K0	Di	Adiv	Aatm	Agr	Afol	Ahous	Abar	Cmet	RL	Lr
	(m)	(m)	(m)			(Hz)	dB(A)	dB	dB	(dB)	(dB)	(dB)	(dB)	(dB)	(dB)	(dB)	(dB)	(dB)	(dB)	dB(A)
6866	340488.87	5028595.57	103.20	0	DEN	A	84.5	0.0	0.0	0.0	0.0	64.6	1.5	-1.3	0.0	0.0	6.4	0.0	0.0	13.3
6881	340488.87	5028595.57	103.20	1	DEN	A	84.5	0.0	0.0	0.0	0.0	65.3	1.6	-1.8	0.0	0.0	6.1	0.0	8.6	4.6
6885	340488.87	5028595.57	103.20	2	DEN	A	84.5	0.0	0.0	0.0	0.0	65.5	1.6	-1.8	0.0	0.0	4.9	0.0	14.2	0.1
6900	340488.87	5028595.57	103.20	1	DEN	A	84.5	0.0	0.0	0.0	0.0	64.8	1.5	-1.2	0.0	0.0	5.1	0.0	6.2	8.1

Point Source, ISO 9613, Name: "Battery Energy Storage System 073", ID: "I0002!BESS073"																				
Nr.	X	Y	Z	Refl.	DEN	Freq.	Lw	l/a	Optime	K0	Di	Adiv	Aatm	Agr	Afol	Ahous	Abar	Cmet	RL	Lr
	(m)	(m)	(m)			(Hz)	dB(A)	dB	dB	(dB)	(dB)	(dB)	(dB)	(dB)	(dB)	(dB)	(dB)	(dB)	(dB)	dB(A)
6909	340648.46	5028600.69	103.95	0	DEN	A	84.4	0.0	0.0	0.0	0.0	64.5	2.1	-1.7	0.0	0.0	13.3	0.0	0.0	6.2
6911	340648.46	5028600.69	103.95	1	DEN	A	84.4	0.0	0.0	0.0	0.0	65.4	2.3	-1.9	0.0	0.0	4.8	0.0	12.6	1.3

Point Source, ISO 9613, Name: "Battery Energy Storage System 182", ID: "I0006!BESS182"																				
Nr.	X	Y	Z	Refl.	DEN	Freq.	Lw	l/a	Optime	K0	Di	Adiv	Aatm	Agr	Afol	Ahous	Abar	Cmet	RL	Lr
	(m)	(m)	(m)			(Hz)	dB(A)	dB	dB	(dB)	(dB)	(dB)	(dB)	(dB)	(dB)	(dB)	(dB)	(dB)	(dB)	dB(A)
6927	340499.55	5028598.07	103.95	0	DEN	A	84.4	0.0	0.0	0.0	0.0	64.5	2.1	-1.9	0.0	0.0	7.8	0.0	0.0	11.9
6948	340499.55	5028598.07	103.95	1	DEN	A	84.4	0.0	0.0	0.0	0.0	65.5	2.3	-2.1	0.0	0.0	4.8	0.0	12.6	1.4

Point Source, ISO 9613, Name: "Battery Energy Storage System 185", ID: "I0006!BESS185"																				
Nr.	X	Y	Z	Refl.	DEN	Freq.	Lw	l/a	Optime	K0	Di	Adiv	Aatm	Agr	Afol	Ahous	Abar	Cmet	RL	Lr
	(m)	(m)	(m)			(Hz)	dB(A)	dB	dB	(dB)	(dB)	(dB)	(dB)	(dB)	(dB)	(dB)	(dB)	(dB)	(dB)	dB(A)
6977	340508.01	5028596.65	103.95	0	DEN	A	84.4	0.0	0.0	0.0	0.0	64.5	2.1	-1.7	0.0	0.0	9.9	0.0	0.0	9.6
6988	340508.01	5028596.65	103.95	1	DEN	A	84.4	0.0	0.0	0.0	0.0	65.6	2.3	-2.2	0.0	0.0	4.8	0.0	12.6	1.4

Sample Calculation at POR3 - Regular Operations

Point Source, ISO 9613, Name: "Battery Energy Storage System 091", ID: "I0005!BESS091"																				
Nr.	X	Y	Z	Refl.	DEN	Freq.	Lw	l/a	Optime	K0	Di	Adiv	Aatm	Agr	Afol	Ahous	Abar	Cmet	RL	Lr
	(m)	(m)	(m)			(Hz)	dB(A)	dB	dB	(dB)	(dB)	(dB)	(dB)	(dB)	(dB)	(dB)	(dB)	(dB)	(dB)	dB(A)
7013	340551.63	5028593.28	103.95	0	DEN	A	84.4	0.0	0.0	0.0	0.0	64.5	2.1	-1.6	0.0	0.0	4.9	0.0	0.0	14.5
7017	340551.63	5028593.28	103.95	1	DEN	A	84.4	0.0	0.0	0.0	0.0	66.1	2.4	-2.2	0.0	0.0	4.8	0.0	12.8	0.5

Point Source, ISO 9613, Name: "Battery Energy Storage System 105", ID: "I0004!BESS105"																				
Nr.	X	Y	Z	Refl.	DEN	Freq.	Lw	l/a	Optime	K0	Di	Adiv	Aatm	Agr	Afol	Ahous	Abar	Cmet	RL	Lr
	(m)	(m)	(m)			(Hz)	dB(A)	dB	dB	(dB)	(dB)	(dB)	(dB)	(dB)	(dB)	(dB)	(dB)	(dB)	(dB)	dB(A)
7047	340588.45	5028592.88	103.95	0	DEN	A	84.4	0.0	0.0	0.0	0.0	64.5	2.1	-1.7	0.0	0.0	13.1	0.0	0.0	6.4

Point Source, ISO 9613, Name: "Battery Energy Storage System 163", ID: "I0007!BESS163"																				
Nr.	X	Y	Z	Refl.	DEN	Freq.	Lw	l/a	Optime	K0	Di	Adiv	Aatm	Agr	Afol	Ahous	Abar	Cmet	RL	Lr
	(m)	(m)	(m)			(Hz)	dB(A)	dB	dB	(dB)	(dB)	(dB)	(dB)	(dB)	(dB)	(dB)	(dB)	(dB)	(dB)	dB(A)
7074	340457.16	5028605.00	103.95	0	DEN	A	84.4	0.0	0.0	0.0	0.0	64.5	2.1	-1.6	0.0	0.0	5.0	0.0	0.0	14.4
7089	340457.16	5028605.00	103.95	1	DEN	A	84.4	0.0	0.0	0.0	0.0	65.0	2.2	-1.6	0.0	0.0	4.8	0.0	3.7	10.3

Point Source, ISO 9613, Name: "Medium Voltage Substation 027", ID: "I02!MVT027"																				
Nr.	X	Y	Z	Refl.	DEN	Freq.	Lw	l/a	Optime	K0	Di	Adiv	Aatm	Agr	Afol	Ahous	Abar	Cmet	RL	Lr
	(m)	(m)	(m)			(Hz)	dB(A)	dB	dB	(dB)	(dB)	(dB)	(dB)	(dB)	(dB)	(dB)	(dB)	(dB)	(dB)	dB(A)
7105	340575.72	5028587.83	103.20	0	DEN	A	84.5	0.0	0.0	0.0	0.0	64.6	1.5	-1.5	0.0	0.0	7.6	0.0	0.0	12.2

Point Source, ISO 9613, Name: "Battery Energy Storage System 064", ID: "I0003!BESS064"																				
Nr.	X	Y	Z	Refl.	DEN	Freq.	Lw	l/a	Optime	K0	Di	Adiv	Aatm	Agr	Afol	Ahous	Abar	Cmet	RL	Lr
	(m)	(m)	(m)			(Hz)	dB(A)	dB	dB	(dB)	(dB)	(dB)	(dB)	(dB)	(dB)	(dB)	(dB)	(dB)	(dB)	dB(A)
7136	340617.19	5028594.56	103.95	0	DEN	A	84.4	0.0	0.0	0.0	0.0	64.5	2.1	-1.7	0.0	0.0	5.2	0.0	0.0	14.3
7138	340617.19	5028594.56	103.95	1	DEN	A	84.4	0.0	0.0	0.0	0.0	64.9	2.2	-1.8	0.0	0.0	4.8	0.0	2.6	11.8

Point Source, ISO 9613, Name: "Battery Energy Storage System 160", ID: "I0007!BESS160"																				
Nr.	X	Y	Z	Refl.	DEN	Freq.	Lw	l/a	Optime	K0	Di	Adiv	Aatm	Agr	Afol	Ahous	Abar	Cmet	RL	Lr
	(m)	(m)	(m)			(Hz)	dB(A)	dB	dB	(dB)	(dB)	(dB)	(dB)	(dB)	(dB)	(dB)	(dB)	(dB)	(dB)	dB(A)
7160	340448.70	5028606.42	103.95	0	DEN	A	84.4	0.0	0.0	0.0	0.0	64.5	2.1	-1.4	0.0	0.0	4.9	0.0	0.0	14.3
7172	340448.70	5028606.42	103.95	1	DEN	A	84.4	0.0	0.0	0.0	0.0	64.9	2.2	-1.4	0.0	0.0	4.7	0.0	2.6	11.3

Point Source, ISO 9613, Name: "Battery Energy Storage System 074", ID: "I0002!BESS074"																				
Nr.	X	Y	Z	Refl.	DEN	Freq.	Lw	l/a	Optime	K0	Di	Adiv	Aatm	Agr	Afol	Ahous	Abar	Cmet	RL	Lr
	(m)	(m)	(m)			(Hz)	dB(A)	dB	dB	(dB)	(dB)	(dB)	(dB)	(dB)	(dB)	(dB)	(dB)	(dB)	(dB)	dB(A)
7188	340647.01	5028598.13	103.95	0	DEN	A	84.4	0.0	0.0	0.0	0.0	64.5	2.1	-1.7	0.0	0.0	10.2	0.0	0.0	9.3
7190	340647.01	5028598.13	103.95	1	DEN	A	84.4	0.0	0.0	0.0	0.0	65.4	2.3	-1.9	0.0	0.0	4.8	0.0	12.5	1.3

Point Source, ISO 9613, Name: "Medium Voltage Substation 047", ID: "I02!MVT047"																				
Nr.	X	Y	Z	Refl.	DEN	Freq.	Lw	l/a	Optime	K0	Di	Adiv	Aatm	Agr	Afol	Ahous	Abar	Cmet	RL	Lr
	(m)	(m)	(m)			(Hz)	dB(A)	dB	dB	(dB)	(dB)	(dB)	(dB)	(dB)	(dB)	(dB)	(dB)	(dB)	(dB)	dB(A)
7220	340495.88	5028591.60	103.20	0	DEN	A	84.5	0.0	0.0	0.0	0.0	64.6	1.5	-1.2	0.0	0.0	6.3	0.0	0.0	13.3
7235	340495.88	5028591.60	103.20	1	DEN	A	84.5	0.0	0.0	0.0	0.0	65.4	1.6	-1.9	0.0	0.0	6.1	0.0	8.6	4.7
7237	340495.88	5028591.60	103.20	2	DEN	A	84.5	0.0	0.0	0.0	0.0	65.5	1.6	-1.9	0.0	0.0	4.9	0.0	14.2	0.1
7252	340495.88	5028591.60	103.20	1	DEN	A	84.5	0.0	0.0	0.0	0.0	64.8	1.5	-1.2	0.0	0.0	5.1	0.0	6.2	8.1

Point Source, ISO 9613, Name: "Battery Energy Storage System 092", ID: "I0005!BESS092"																				
Nr.	X	Y	Z	Refl.	DEN	Freq.	Lw	l/a	Optime	K0	Di	Adiv	Aatm	Agr	Afol	Ahous	Abar	Cmet	RL	Lr
	(m)	(m)	(m)			(Hz)	dB(A)	dB	dB	(dB)	(dB)	(dB)	(dB)	(dB)	(dB)	(dB)	(dB)	(dB)	(dB)	dB(A)
7269	340550.18	5028590.72	103.95	0	DEN	A	84.4	0.0	0.0	0.0	0.0	64.5	2.1	-1.6	0.0	0.0	4.9	0.0	0.0	14.5
7279	340550.18	5028590.72	103.95	1	DEN	A	84.4	0.0	0.0	0.0	0.0	66.0	2.4	-2.0	0.0	0.0	4.8	0.0	12.8	0.5
7291	340550.18	5028590.72	103.95	2	DEN	A	84.4	0.0	0.0	0.0	0.0	64.7	2.1	-1.7	0.0	0.0	4.8	0.0	14.4	0.1

Point Source, ISO 9613, Name: "Battery Energy Storage System 186", ID: "I0006!BESS186"																				
Nr.	X	Y	Z	Refl.	DEN	Freq.	Lw	l/a	Optime	K0	Di	Adiv	Aatm	Agr	Afol	Ahous	Abar	Cmet	RL	Lr
	(m)	(m)	(m)			(Hz)	dB(A)	dB	dB	(dB)	(dB)	(dB)	(dB)	(dB)	(dB)	(dB)	(dB)	(dB)	(dB)	dB(A)
7300	340506.56	5028594.09	103.95	0	DEN	A	84.4	0.0	0.0	0.0	0.0	64.5	2.1	-1.7	0.0	0.0	7.5	0.0	0.0	11.9
7312	340506.56	5028594.09	103.95	1	DEN	A	84.4	0.0	0.0	0.0	0.0	65.5	2.3	-2.2	0.0	0.0	4.8	0.0	12.6	1.4

Point Source, ISO 9613, Name: "Battery Energy Storage System 167", ID: "I0007!BESS167"																				
Nr.	X	Y	Z	Refl.	DEN	Freq.	Lw	l/a	Optime	K0	Di	Adiv	Aatm	Agr	Afol	Ahous	Abar	Cmet	RL	Lr
	(m)	(m)	(m)			(Hz)	dB(A)	dB	dB	(dB)	(dB)	(dB)	(dB)	(dB)	(dB)	(dB)	(dB)	(dB)	(dB)	dB(A)
7335	340464.17	5028601.02	103.95	0	DEN	A	84.4	0.0	0.0	0.0	0.0	64.5	2.1	-1.7	0.0	0.0	5.0	0.0	0.0	14.5
7348	340464.17	5028601.02	103.95	1	DEN	A	84.4	0.0	0.0	0.0	0.0	65.1	2.2	-1.7	0.0	0.0	4.8	0.0	3.7	10.3

Sample Calculation at POR3 - Regular Operations

Point Source, ISO 9613, Name: "Battery Energy Storage System 106", ID: "I0004!BESS106"																				
Nr.	X	Y	Z	Refl.	DEN	Freq.	Lw	l/a	Optime	K0	Di	Adiv	Aatm	Agr	Afol	Ahous	Abar	Cmet	RL	Lr
	(m)	(m)	(m)			(Hz)	dB(A)	dB	dB	(dB)	(dB)	(dB)	(dB)	(dB)	(dB)	(dB)	(dB)	(dB)	(dB)	dB(A)
7369	340587.00	5028590.32	103.95	0	DEN	A	84.4	0.0	0.0	0.0	0.0	64.6	2.1	-1.7	0.0	0.0	10.0	0.0	0.0	9.5

Point Source, ISO 9613, Name: "Medium Voltage Substation 019", ID: "I02!MVT019"																				
Nr.	X	Y	Z	Refl.	DEN	Freq.	Lw	l/a	Optime	K0	Di	Adiv	Aatm	Agr	Afol	Ahous	Abar	Cmet	RL	Lr
	(m)	(m)	(m)			(Hz)	dB(A)	dB	dB	(dB)	(dB)	(dB)	(dB)	(dB)	(dB)	(dB)	(dB)	(dB)	(dB)	dB(A)
7389	340643.34	5028591.66	103.20	0	DEN	A	84.5	0.0	0.0	0.0	0.0	64.6	1.5	-1.5	0.0	0.0	7.9	0.0	0.0	11.9
7390	340643.34	5028591.66	103.20	1	DEN	A	84.5	0.0	0.0	0.0	0.0	65.3	1.6	-1.7	0.0	0.0	6.0	0.0	8.6	4.7

Point Source, ISO 9613, Name: "Battery Energy Storage System 164", ID: "I0007!BESS164"																				
Nr.	X	Y	Z	Refl.	DEN	Freq.	Lw	l/a	Optime	K0	Di	Adiv	Aatm	Agr	Afol	Ahous	Abar	Cmet	RL	Lr
	(m)	(m)	(m)			(Hz)	dB(A)	dB	dB	(dB)	(dB)	(dB)	(dB)	(dB)	(dB)	(dB)	(dB)	(dB)	(dB)	dB(A)
7422	340455.71	5028602.44	103.95	0	DEN	A	84.4	0.0	0.0	0.0	0.0	64.6	2.1	-1.6	0.0	0.0	4.9	0.0	0.0	14.5
7432	340455.71	5028602.44	103.95	1	DEN	A	84.4	0.0	0.0	0.0	0.0	65.0	2.2	-1.6	0.0	0.0	4.8	0.0	2.6	11.4

Point Source, ISO 9613, Name: "Battery Energy Storage System 067", ID: "I0003!BESS067"																				
Nr.	X	Y	Z	Refl.	DEN	Freq.	Lw	l/a	Optime	K0	Di	Adiv	Aatm	Agr	Afol	Ahous	Abar	Cmet	RL	Lr
	(m)	(m)	(m)			(Hz)	dB(A)	dB	dB	(dB)	(dB)	(dB)	(dB)	(dB)	(dB)	(dB)	(dB)	(dB)	(dB)	dB(A)
7451	340625.65	5028593.14	103.95	0	DEN	A	84.4	0.0	0.0	0.0	0.0	64.6	2.1	-1.7	0.0	0.0	5.4	0.0	0.0	14.1
7452	340625.65	5028593.14	103.95	1	DEN	A	84.4	0.0	0.0	0.0	0.0	65.0	2.2	-1.8	0.0	0.0	4.8	0.0	3.7	10.5

Point Source, ISO 9613, Name: "Battery Energy Storage System 095", ID: "I0005!BESS095"																				
Nr.	X	Y	Z	Refl.	DEN	Freq.	Lw	l/a	Optime	K0	Di	Adiv	Aatm	Agr	Afol	Ahous	Abar	Cmet	RL	Lr
	(m)	(m)	(m)			(Hz)	dB(A)	dB	dB	(dB)	(dB)	(dB)	(dB)	(dB)	(dB)	(dB)	(dB)	(dB)	(dB)	dB(A)
7480	340558.64	5028589.31	103.95	0	DEN	A	84.4	0.0	0.0	0.0	0.0	64.6	2.1	-1.7	0.0	0.0	4.9	0.0	0.0	14.5

Point Source, ISO 9613, Name: "Battery Energy Storage System 077", ID: "I0002!BESS077"																				
Nr.	X	Y	Z	Refl.	DEN	Freq.	Lw	l/a	Optime	K0	Di	Adiv	Aatm	Agr	Afol	Ahous	Abar	Cmet	RL	Lr
	(m)	(m)	(m)			(Hz)	dB(A)	dB	dB	(dB)	(dB)	(dB)	(dB)	(dB)	(dB)	(dB)	(dB)	(dB)	(dB)	dB(A)
7508	340655.47	5028596.71	103.95	0	DEN	A	84.4	0.0	0.0	0.0	0.0	64.6	2.1	-1.7	0.0	0.0	13.2	0.0	0.0	6.1
7509	340655.47	5028596.71	103.95	1	DEN	A	84.4	0.0	0.0	0.0	0.0	65.5	2.3	-1.9	0.0	0.0	4.8	0.0	12.6	1.2

Point Source, ISO 9613, Name: "Battery Energy Storage System 109", ID: "I0004!BESS109"																				
Nr.	X	Y	Z	Refl.	DEN	Freq.	Lw	l/a	Optime	K0	Di	Adiv	Aatm	Agr	Afol	Ahous	Abar	Cmet	RL	Lr
	(m)	(m)	(m)			(Hz)	dB(A)	dB	dB	(dB)	(dB)	(dB)	(dB)	(dB)	(dB)	(dB)	(dB)	(dB)	(dB)	dB(A)
7537	340595.46	5028588.90	103.95	0	DEN	A	84.4	0.0	0.0	0.0	0.0	64.6	2.1	-1.7	0.0	0.0	13.1	0.0	0.0	6.3

Point Source, ISO 9613, Name: "Medium Voltage Substation 028", ID: "I02!MVT028"																				
Nr.	X	Y	Z	Refl.	DEN	Freq.	Lw	l/a	Optime	K0	Di	Adiv	Aatm	Agr	Afol	Ahous	Abar	Cmet	RL	Lr
	(m)	(m)	(m)			(Hz)	dB(A)	dB	dB	(dB)	(dB)	(dB)	(dB)	(dB)	(dB)	(dB)	(dB)	(dB)	(dB)	dB(A)
7550	340582.73	5028583.85	103.20	0	DEN	A	84.5	0.0	0.0	0.0	0.0	64.7	1.5	-1.6	0.0	0.0	7.6	0.0	0.0	12.3

Point Source, ISO 9613, Name: "Medium Voltage Substation 048", ID: "I02!MVT048"																				
Nr.	X	Y	Z	Refl.	DEN	Freq.	Lw	l/a	Optime	K0	Di	Adiv	Aatm	Agr	Afol	Ahous	Abar	Cmet	RL	Lr
	(m)	(m)	(m)			(Hz)	dB(A)	dB	dB	(dB)	(dB)	(dB)	(dB)	(dB)	(dB)	(dB)	(dB)	(dB)	(dB)	dB(A)
7577	340502.89	5028587.62	103.20	0	DEN	A	84.5	0.0	0.0	0.0	0.0	64.7	1.5	-1.0	0.0	0.0	6.1	0.0	0.0	13.2
7584	340502.89	5028587.62	103.20	1	DEN	A	84.5	0.0	0.0	0.0	0.0	65.4	1.6	-1.9	0.0	0.0	6.1	0.0	8.6	4.7
7586	340502.89	5028587.62	103.20	2	DEN	A	84.5	0.0	0.0	0.0	0.0	65.6	1.7	-2.0	0.0	0.0	4.9	0.0	14.2	0.1
7599	340502.89	5028587.62	103.20	1	DEN	A	84.5	0.0	0.0	0.0	0.0	64.9	1.5	-1.2	0.0	0.0	5.1	0.0	6.2	8.0

Point Source, ISO 9613, Name: "Battery Energy Storage System 171", ID: "I0007!BESS171"																				
Nr.	X	Y	Z	Refl.	DEN	Freq.	Lw	l/a	Optime	K0	Di	Adiv	Aatm	Agr	Afol	Ahous	Abar	Cmet	RL	Lr
	(m)	(m)	(m)			(Hz)	dB(A)	dB	dB	(dB)	(dB)	(dB)	(dB)	(dB)	(dB)	(dB)	(dB)	(dB)	(dB)	dB(A)
7621	340471.18	5028597.05	103.95	0	DEN	A	84.4	0.0	0.0	0.0	0.0	64.6	2.1	-1.8	0.0	0.0	5.0	0.0	0.0	14.5
7630	340471.18	5028597.05	103.95	1	DEN	A	84.4	0.0	0.0	0.0	0.0	65.1	2.2	-1.7	0.0	0.0	4.8	0.0	3.7	10.4

Point Source, ISO 9613, Name: "Battery Energy Storage System 168", ID: "I0007!BESS168"																				
Nr.	X	Y	Z	Refl.	DEN	Freq.	Lw	l/a	Optime	K0	Di	Adiv	Aatm	Agr	Afol	Ahous	Abar	Cmet	RL	Lr
	(m)	(m)	(m)			(Hz)	dB(A)	dB	dB	(dB)	(dB)	(dB)	(dB)	(dB)	(dB)	(dB)	(dB)	(dB)	(dB)	dB(A)
7653	340462.72	5028598.47	103.95	0	DEN	A	84.4	0.0	0.0	0.0	0.0	64.6	2.1	-1.7	0.0	0.0	4.9	0.0	0.0	14.5
7666	340462.72	5028598.47	103.95	1	DEN	A	84.4	0.0	0.0	0.0	0.0	65.0	2.2	-1.6	0.0	0.0	4.8	0.0	2.6	11.5

Sample Calculation at POR3 - Regular Operations

Point Source, ISO 9613, Name: "Battery Energy Storage System 068", ID: "I0003!BESS068"																				
Nr.	X	Y	Z	Refl.	DEN	Freq.	Lw	l/a	Optime	K0	Di	Adiv	Aatm	Agr	Afol	Ahous	Abar	Cmet	RL	Lr
	(m)	(m)	(m)			(Hz)	dB(A)	dB	dB	(dB)	(dB)	(dB)	(dB)	(dB)	(dB)	(dB)	(dB)	(dB)	(dB)	dB(A)
7689	340624.20	5028590.59	103.95	0	DEN	A	84.4	0.0	0.0	0.0	0.0	64.6	2.1	-1.7	0.0	0.0	5.2	0.0	0.0	14.2
7690	340624.20	5028590.59	103.95	1	DEN	A	84.4	0.0	0.0	0.0	0.0	65.0	2.2	-1.8	0.0	0.0	4.8	0.0	2.6	11.6

Point Source, ISO 9613, Name: "Battery Energy Storage System 096", ID: "I0005!BESS096"																				
Nr.	X	Y	Z	Refl.	DEN	Freq.	Lw	l/a	Optime	K0	Di	Adiv	Aatm	Agr	Afol	Ahous	Abar	Cmet	RL	Lr
	(m)	(m)	(m)			(Hz)	dB(A)	dB	dB	(dB)	(dB)	(dB)	(dB)	(dB)	(dB)	(dB)	(dB)	(dB)	(dB)	dB(A)
7716	340557.19	5028586.75	103.95	0	DEN	A	84.4	0.0	0.0	0.0	0.0	64.6	2.1	-1.7	0.0	0.0	4.8	0.0	0.0	14.5

Point Source, ISO 9613, Name: "Battery Energy Storage System 078", ID: "I0002!BESS078"																				
Nr.	X	Y	Z	Refl.	DEN	Freq.	Lw	l/a	Optime	K0	Di	Adiv	Aatm	Agr	Afol	Ahous	Abar	Cmet	RL	Lr
	(m)	(m)	(m)			(Hz)	dB(A)	dB	dB	(dB)	(dB)	(dB)	(dB)	(dB)	(dB)	(dB)	(dB)	(dB)	(dB)	dB(A)
7743	340654.02	5028594.16	103.95	0	DEN	A	84.4	0.0	0.0	0.0	0.0	64.6	2.1	-1.7	0.0	0.0	10.2	0.0	0.0	9.2
7744	340654.02	5028594.16	103.95	1	DEN	A	84.4	0.0	0.0	0.0	0.0	65.4	2.3	-1.9	0.0	0.0	4.8	0.0	12.6	1.2

Point Source, ISO 9613, Name: "Battery Energy Storage System 110", ID: "I0004!BESS110"																				
Nr.	X	Y	Z	Refl.	DEN	Freq.	Lw	l/a	Optime	K0	Di	Adiv	Aatm	Agr	Afol	Ahous	Abar	Cmet	RL	Lr
	(m)	(m)	(m)			(Hz)	dB(A)	dB	dB	(dB)	(dB)	(dB)	(dB)	(dB)	(dB)	(dB)	(dB)	(dB)	(dB)	dB(A)
7766	340594.01	5028586.35	103.95	0	DEN	A	84.4	0.0	0.0	0.0	0.0	64.6	2.1	-1.7	0.0	0.0	9.9	0.0	0.0	9.5

Point Source, ISO 9613, Name: "Battery Energy Storage System 099", ID: "I0005!BESS099"																				
Nr.	X	Y	Z	Refl.	DEN	Freq.	Lw	l/a	Optime	K0	Di	Adiv	Aatm	Agr	Afol	Ahous	Abar	Cmet	RL	Lr
	(m)	(m)	(m)			(Hz)	dB(A)	dB	dB	(dB)	(dB)	(dB)	(dB)	(dB)	(dB)	(dB)	(dB)	(dB)	(dB)	dB(A)
7794	340565.64	5028585.33	103.95	0	DEN	A	84.4	0.0	0.0	0.0	0.0	64.6	2.1	-1.7	0.0	0.0	5.2	0.0	0.0	14.2

Point Source, ISO 9613, Name: "Battery Energy Storage System 175", ID: "I0007!BESS175"																				
Nr.	X	Y	Z	Refl.	DEN	Freq.	Lw	l/a	Optime	K0	Di	Adiv	Aatm	Agr	Afol	Ahous	Abar	Cmet	RL	Lr
	(m)	(m)	(m)			(Hz)	dB(A)	dB	dB	(dB)	(dB)	(dB)	(dB)	(dB)	(dB)	(dB)	(dB)	(dB)	(dB)	dB(A)
7827	340478.19	5028593.07	103.95	0	DEN	A	84.4	0.0	0.0	0.0	0.0	64.6	2.1	-1.9	0.0	0.0	4.9	0.0	0.0	14.6
7837	340478.19	5028593.07	103.95	1	DEN	A	84.4	0.0	0.0	0.0	0.0	65.2	2.2	-1.8	0.0	0.0	4.8	0.0	3.7	10.4

Point Source, ISO 9613, Name: "Battery Energy Storage System 172", ID: "I0007!BESS172"																				
Nr.	X	Y	Z	Refl.	DEN	Freq.	Lw	l/a	Optime	K0	Di	Adiv	Aatm	Agr	Afol	Ahous	Abar	Cmet	RL	Lr
	(m)	(m)	(m)			(Hz)	dB(A)	dB	dB	(dB)	(dB)	(dB)	(dB)	(dB)	(dB)	(dB)	(dB)	(dB)	(dB)	dB(A)
7861	340469.73	5028594.49	103.95	0	DEN	A	84.4	0.0	0.0	0.0	0.0	64.6	2.1	-1.8	0.0	0.0	4.9	0.0	0.0	14.5
7870	340469.73	5028594.49	103.95	1	DEN	A	84.4	0.0	0.0	0.0	0.0	65.1	2.2	-1.8	0.0	0.0	4.8	0.0	2.6	11.6

Point Source, ISO 9613, Name: "Medium Voltage Substation 020", ID: "I02!MVT020"																				
Nr.	X	Y	Z	Refl.	DEN	Freq.	Lw	l/a	Optime	K0	Di	Adiv	Aatm	Agr	Afol	Ahous	Abar	Cmet	RL	Lr
	(m)	(m)	(m)			(Hz)	dB(A)	dB	dB	(dB)	(dB)	(dB)	(dB)	(dB)	(dB)	(dB)	(dB)	(dB)	(dB)	dB(A)
7894	340650.35	5028587.69	103.20	0	DEN	A	84.5	0.0	0.0	0.0	0.0	64.7	1.5	-1.6	0.0	0.0	7.9	0.0	0.0	11.9
7895	340650.35	5028587.69	103.20	1	DEN	A	84.5	0.0	0.0	0.0	0.0	65.3	1.6	-1.6	0.0	0.0	6.0	0.0	8.6	4.5

Point Source, ISO 9613, Name: "Battery Energy Storage System 071", ID: "I0003!BESS071"																				
Nr.	X	Y	Z	Refl.	DEN	Freq.	Lw	l/a	Optime	K0	Di	Adiv	Aatm	Agr	Afol	Ahous	Abar	Cmet	RL	Lr
	(m)	(m)	(m)			(Hz)	dB(A)	dB	dB	(dB)	(dB)	(dB)	(dB)	(dB)	(dB)	(dB)	(dB)	(dB)	(dB)	dB(A)
7923	340632.66	5028589.17	103.95	0	DEN	A	84.4	0.0	0.0	0.0	0.0	64.6	2.1	-1.8	0.0	0.0	5.4	0.0	0.0	14.0
7925	340632.66	5028589.17	103.95	1	DEN	A	84.4	0.0	0.0	0.0	0.0	65.1	2.2	-1.8	0.0	0.0	4.8	0.0	3.7	10.4

Point Source, ISO 9613, Name: "Medium Voltage Substation 029", ID: "I02!MVT029"																				
Nr.	X	Y	Z	Refl.	DEN	Freq.	Lw	l/a	Optime	K0	Di	Adiv	Aatm	Agr	Afol	Ahous	Abar	Cmet	RL	Lr
	(m)	(m)	(m)			(Hz)	dB(A)	dB	dB	(dB)	(dB)	(dB)	(dB)	(dB)	(dB)	(dB)	(dB)	(dB)	(dB)	dB(A)
7947	340589.74	5028579.88	103.20	0	DEN	A	84.5	0.0	0.0	0.0	0.0	64.7	1.5	-1.6	0.0	0.0	7.5	0.0	0.0	12.2

Point Source, ISO 9613, Name: "Battery Energy Storage System 113", ID: "I0004!BESS113"																				
Nr.	X	Y	Z	Refl.	DEN	Freq.	Lw	l/a	Optime	K0	Di	Adiv	Aatm	Agr	Afol	Ahous	Abar	Cmet	RL	Lr
	(m)	(m)	(m)			(Hz)	dB(A)	dB	dB	(dB)	(dB)	(dB)	(dB)	(dB)	(dB)	(dB)	(dB)	(dB)	(dB)	dB(A)
7978	340602.47	5028584.93	103.95	0	DEN	A	84.4	0.0	0.0	0.0	0.0	64.7	2.1	-1.7	0.0	0.0	13.5	0.0	0.0	5.9

Point Source, ISO 9613, Name: "Battery Energy Storage System 081", ID: "I0002!BESS081"																				
Nr.	X	Y	Z	Refl.	DEN	Freq.	Lw	l/a	Optime	K0	Di	Adiv	Aatm	Agr	Afol	Ahous	Abar	Cmet	RL	Lr
	(m)	(m)	(m)			(Hz)	dB(A)	dB	dB	(dB)	(dB)	(dB)	(dB)	(dB)	(dB)	(dB)	(dB)	(dB)	(dB)	dB(A)
7998	340662.48	5028592.74	103.95	0	DEN	A	84.4	0.0	0.0	0.0	0.0	64.7	2.1	-1.7	0.0	0.0	13.2	0.0	0.0	6.1
7999	340662.48	5028592.74	103.95	1	DEN	A	84.4	0.0	0.0	0.0	0.0	65.6	2.3	-2.0	0.0	0.0	4.8	0.0	12.6	1.1

Sample Calculation at POR3 - Regular Operations

Point Source, ISO 9613, Name: "Battery Energy Storage System 100", ID: "I0005!BESS100"																				
Nr.	X	Y	Z	Refl.	DEN	Freq.	Lw	l/a	Optime	K0	Di	Adiv	Aatm	Agr	Afol	Ahous	Abar	Cmet	RL	Lr
	(m)	(m)	(m)			(Hz)	dB(A)	dB	dB	(dB)	(dB)	(dB)	(dB)	(dB)	(dB)	(dB)	(dB)	(dB)	(dB)	dB(A)
8027	340564.20	5028582.78	103.95	0	DEN	A	84.4	0.0	0.0	0.0	0.0	64.7	2.1	-1.7	0.0	0.0	5.0	0.0	0.0	14.3

Point Source, ISO 9613, Name: "Battery Energy Storage System 179", ID: "I0007!BESS179"																				
Nr.	X	Y	Z	Refl.	DEN	Freq.	Lw	l/a	Optime	K0	Di	Adiv	Aatm	Agr	Afol	Ahous	Abar	Cmet	RL	Lr
	(m)	(m)	(m)			(Hz)	dB(A)	dB	dB	(dB)	(dB)	(dB)	(dB)	(dB)	(dB)	(dB)	(dB)	(dB)	(dB)	dB(A)
8055	340485.20	5028589.10	103.95	0	DEN	A	84.4	0.0	0.0	0.0	0.0	64.7	2.1	-1.9	0.0	0.0	4.9	0.0	0.0	14.6
8062	340485.20	5028589.10	103.95	1	DEN	A	84.4	0.0	0.0	0.0	0.0	65.2	2.2	-1.9	0.0	0.0	4.8	0.0	3.7	10.4

Point Source, ISO 9613, Name: "Battery Energy Storage System 072", ID: "I0003!BESS072"																				
Nr.	X	Y	Z	Refl.	DEN	Freq.	Lw	l/a	Optime	K0	Di	Adiv	Aatm	Agr	Afol	Ahous	Abar	Cmet	RL	Lr
	(m)	(m)	(m)			(Hz)	dB(A)	dB	dB	(dB)	(dB)	(dB)	(dB)	(dB)	(dB)	(dB)	(dB)	(dB)	(dB)	dB(A)
8089	340631.21	5028586.61	103.95	0	DEN	A	84.4	0.0	0.0	0.0	0.0	64.7	2.1	-1.8	0.0	0.0	5.2	0.0	0.0	14.2
8090	340631.21	5028586.61	103.95	1	DEN	A	84.4	0.0	0.0	0.0	0.0	65.0	2.2	-1.8	0.0	0.0	4.8	0.0	2.6	11.6

Point Source, ISO 9613, Name: "Battery Energy Storage System 176", ID: "I0007!BESS176"																				
Nr.	X	Y	Z	Refl.	DEN	Freq.	Lw	l/a	Optime	K0	Di	Adiv	Aatm	Agr	Afol	Ahous	Abar	Cmet	RL	Lr
	(m)	(m)	(m)			(Hz)	dB(A)	dB	dB	(dB)	(dB)	(dB)	(dB)	(dB)	(dB)	(dB)	(dB)	(dB)	(dB)	dB(A)
8116	340476.74	5028590.52	103.95	0	DEN	A	84.4	0.0	0.0	0.0	0.0	64.7	2.1	-1.9	0.0	0.0	4.9	0.0	0.0	14.6
8128	340476.74	5028590.52	103.95	1	DEN	A	84.4	0.0	0.0	0.0	0.0	65.1	2.2	-1.8	0.0	0.0	4.8	0.0	2.6	11.6

Point Source, ISO 9613, Name: "Battery Energy Storage System 192", ID: "I0008!BESS192"																				
Nr.	X	Y	Z	Refl.	DEN	Freq.	Lw	l/a	Optime	K0	Di	Adiv	Aatm	Agr	Afol	Ahous	Abar	Cmet	RL	Lr
	(m)	(m)	(m)			(Hz)	dB(A)	dB	dB	(dB)	(dB)	(dB)	(dB)	(dB)	(dB)	(dB)	(dB)	(dB)	(dB)	dB(A)
8148	340419.96	5028604.74	103.95	0	DEN	A	84.4	0.0	0.0	0.0	0.0	64.7	2.1	-1.2	0.0	0.0	13.2	0.0	0.0	5.5
8149	340419.96	5028604.74	103.95	1	DEN	A	84.4	0.0	0.0	0.0	0.0	65.8	2.4	-1.8	0.0	0.0	4.8	0.0	12.7	0.6

Point Source, ISO 9613, Name: "Battery Energy Storage System 103", ID: "I0005!BESS103"																				
Nr.	X	Y	Z	Refl.	DEN	Freq.	Lw	l/a	Optime	K0	Di	Adiv	Aatm	Agr	Afol	Ahous	Abar	Cmet	RL	Lr
	(m)	(m)	(m)			(Hz)	dB(A)	dB	dB	(dB)	(dB)	(dB)	(dB)	(dB)	(dB)	(dB)	(dB)	(dB)	(dB)	dB(A)
8172	340572.65	5028581.36	103.95	0	DEN	A	84.4	0.0	0.0	0.0	0.0	64.7	2.1	-1.8	0.0	0.0	5.2	0.0	0.0	14.2

Point Source, ISO 9613, Name: "Battery Energy Storage System 114", ID: "I0004!BESS114"																				
Nr.	X	Y	Z	Refl.	DEN	Freq.	Lw	l/a	Optime	K0	Di	Adiv	Aatm	Agr	Afol	Ahous	Abar	Cmet	RL	Lr
	(m)	(m)	(m)			(Hz)	dB(A)	dB	dB	(dB)	(dB)	(dB)	(dB)	(dB)	(dB)	(dB)	(dB)	(dB)	(dB)	dB(A)
8202	340601.02	5028582.37	103.95	0	DEN	A	84.4	0.0	0.0	0.0	0.0	64.7	2.1	-1.7	0.0	0.0	10.3	0.0	0.0	8.9

Point Source, ISO 9613, Name: "Battery Energy Storage System 189", ID: "I0008!BESS189"																				
Nr.	X	Y	Z	Refl.	DEN	Freq.	Lw	l/a	Optime	K0	Di	Adiv	Aatm	Agr	Afol	Ahous	Abar	Cmet	RL	Lr
	(m)	(m)	(m)			(Hz)	dB(A)	dB	dB	(dB)	(dB)	(dB)	(dB)	(dB)	(dB)	(dB)	(dB)	(dB)	(dB)	dB(A)
8222	340411.50	5028606.15	103.95	0	DEN	A	84.4	0.0	0.0	0.0	0.0	64.7	2.1	-1.2	0.0	0.0	7.2	0.0	0.0	11.5

Point Source, ISO 9613, Name: "Battery Energy Storage System 082", ID: "I0002!BESS082"																				
Nr.	X	Y	Z	Refl.	DEN	Freq.	Lw	l/a	Optime	K0	Di	Adiv	Aatm	Agr	Afol	Ahous	Abar	Cmet	RL	Lr
	(m)	(m)	(m)			(Hz)	dB(A)	dB	dB	(dB)	(dB)	(dB)	(dB)	(dB)	(dB)	(dB)	(dB)	(dB)	(dB)	dB(A)
8227	340661.03	5028590.18	103.95	0	DEN	A	84.4	0.0	0.0	0.0	0.0	64.7	2.1	-1.7	0.0	0.0	10.2	0.0	0.0	9.1
8229	340661.03	5028590.18	103.95	1	DEN	A	84.4	0.0	0.0	0.0	0.0	65.5	2.3	-1.9	0.0	0.0	4.8	0.0	12.6	1.1

Point Source, ISO 9613, Name: "Battery Energy Storage System 196", ID: "I0008!BESS196"																				
Nr.	X	Y	Z	Refl.	DEN	Freq.	Lw	l/a	Optime	K0	Di	Adiv	Aatm	Agr	Afol	Ahous	Abar	Cmet	RL	Lr
	(m)	(m)	(m)			(Hz)	dB(A)	dB	dB	(dB)	(dB)	(dB)	(dB)	(dB)	(dB)	(dB)	(dB)	(dB)	(dB)	dB(A)
8248	340426.97	5028600.77	103.95	0	DEN	A	84.4	0.0	0.0	0.0	0.0	64.7	2.1	-1.2	0.0	0.0	13.6	0.0	0.0	5.1
8249	340426.97	5028600.77	103.95	1	DEN	A	84.4	0.0	0.0	0.0	0.0	65.8	2.4	-1.8	0.0	0.0	4.8	0.0	12.7	0.6

Point Source, ISO 9613, Name: "Battery Energy Storage System 075", ID: "I0003!BESS075"																				
Nr.	X	Y	Z	Refl.	DEN	Freq.	Lw	l/a	Optime	K0	Di	Adiv	Aatm	Agr	Afol	Ahous	Abar	Cmet	RL	Lr
	(m)	(m)	(m)			(Hz)	dB(A)	dB	dB	(dB)	(dB)	(dB)	(dB)	(dB)	(dB)	(dB)	(dB)	(dB)	(dB)	dB(A)
8277	340639.67	5028585.19	103.95	0	DEN	A	84.4	0.0	0.0	0.0	0.0	64.7	2.2	-1.8	0.0	0.0	5.4	0.0	0.0	13.9
8279	340639.67	5028585.19	103.95	1	DEN	A	84.4	0.0	0.0	0.0	0.0	65.2	2.2	-1.9	0.0	0.0	4.8	0.0	3.7	10.4

Point Source, ISO 9613, Name: "Battery Energy Storage System 180", ID: "I0007!BESS180"																				
Nr.	X	Y	Z	Refl.	DEN	Freq.	Lw	l/a	Optime	K0	Di	Adiv	Aatm	Agr	Afol	Ahous	Abar	Cmet	RL	Lr
	(m)	(m)	(m)			(Hz)	dB(A)	dB	dB	(dB)	(dB)	(dB)	(dB)	(dB)	(dB)	(dB)	(dB)	(dB)	(dB)	dB(A)
8304	340483.75	5028586.54	103.95	0	DEN	A	84.4	0.0	0.0	0.0	0.0	64.7	2.2	-1.9	0.0	0.0	4.9	0.0	0.0	14.6
8315	340483.75	5028586.54	103.95	1	DEN	A	84.4	0.0	0.0	0.0	0.0	65.1	2.2	-1.9	0.0	0.0	4.8	0.0	2.6	11.6

Sample Calculation at POR3 - Regular Operations

Point Source, ISO 9613, Name: "Medium Voltage Substation 021", ID: "I02!MVT021"																				
Nr.	X	Y	Z	Refl.	DEN	Freq.	Lw	l/a	Optime	K0	Di	Adiv	Aatm	Agr	Afol	Ahous	Abar	Cmet	RL	Lr
	(m)	(m)	(m)			(Hz)	dB(A)	dB	dB	(dB)	(dB)	(dB)	(dB)	(dB)	(dB)	(dB)	(dB)	(dB)	(dB)	dB(A)
8338	340657.36	5028583.71	103.20	0	DEN	A	84.5	0.0	0.0	0.0	0.0	64.8	1.5	-1.6	0.0	0.0	7.8	0.0	0.0	11.9
8339	340657.36	5028583.71	103.20	1	DEN	A	84.5	0.0	0.0	0.0	0.0	65.4	1.6	-1.7	0.0	0.0	6.1	0.0	8.7	4.4
8355	340657.36	5028583.71	103.20	1	DEN	A	84.5	0.0	0.0	0.0	0.0	65.0	1.6	-1.6	0.0	0.0	5.6	0.0	7.2	6.7

Point Source, ISO 9613, Name: "Battery Energy Storage System 183", ID: "I0007!BESS183"																				
Nr.	X	Y	Z	Refl.	DEN	Freq.	Lw	l/a	Optime	K0	Di	Adiv	Aatm	Agr	Afol	Ahous	Abar	Cmet	RL	Lr
	(m)	(m)	(m)			(Hz)	dB(A)	dB	dB	(dB)	(dB)	(dB)	(dB)	(dB)	(dB)	(dB)	(dB)	(dB)	(dB)	dB(A)
8368	340492.21	5028585.12	103.95	0	DEN	A	84.4	0.0	0.0	0.0	0.0	64.7	2.2	-2.0	0.0	0.0	4.9	0.0	0.0	14.6
8376	340492.21	5028585.12	103.95	1	DEN	A	84.4	0.0	0.0	0.0	0.0	65.2	2.3	-2.0	0.0	0.0	4.8	0.0	3.7	10.5

Point Source, ISO 9613, Name: "Medium Voltage Substation 030", ID: "I02!MVT030"																				
Nr.	X	Y	Z	Refl.	DEN	Freq.	Lw	l/a	Optime	K0	Di	Adiv	Aatm	Agr	Afol	Ahous	Abar	Cmet	RL	Lr
	(m)	(m)	(m)			(Hz)	dB(A)	dB	dB	(dB)	(dB)	(dB)	(dB)	(dB)	(dB)	(dB)	(dB)	(dB)	(dB)	dB(A)
8397	340596.75	5028575.90	103.20	0	DEN	A	84.5	0.0	0.0	0.0	0.0	64.8	1.5	-1.6	0.0	0.0	7.5	0.0	0.0	12.2

Point Source, ISO 9613, Name: "Battery Energy Storage System 193", ID: "I0008!BESS193"																				
Nr.	X	Y	Z	Refl.	DEN	Freq.	Lw	l/a	Optime	K0	Di	Adiv	Aatm	Agr	Afol	Ahous	Abar	Cmet	RL	Lr
	(m)	(m)	(m)			(Hz)	dB(A)	dB	dB	(dB)	(dB)	(dB)	(dB)	(dB)	(dB)	(dB)	(dB)	(dB)	(dB)	dB(A)
8421	340418.51	5028602.18	103.95	0	DEN	A	84.4	0.0	0.0	0.0	0.0	64.7	2.2	-1.2	0.0	0.0	10.3	0.0	0.0	8.4
8424	340418.51	5028602.18	103.95	1	DEN	A	84.4	0.0	0.0	0.0	0.0	65.7	2.4	-1.8	0.0	0.0	4.8	0.0	3.8	9.6

Point Source, ISO 9613, Name: "Battery Energy Storage System 117", ID: "I0004!BESS117"																				
Nr.	X	Y	Z	Refl.	DEN	Freq.	Lw	l/a	Optime	K0	Di	Adiv	Aatm	Agr	Afol	Ahous	Abar	Cmet	RL	Lr
	(m)	(m)	(m)			(Hz)	dB(A)	dB	dB	(dB)	(dB)	(dB)	(dB)	(dB)	(dB)	(dB)	(dB)	(dB)	(dB)	dB(A)
8447	340609.48	5028580.96	103.95	0	DEN	A	84.4	0.0	0.0	0.0	0.0	64.7	2.2	-1.7	0.0	0.0	13.4	0.0	0.0	5.8

Point Source, ISO 9613, Name: "Battery Energy Storage System 104", ID: "I0005!BESS104"																				
Nr.	X	Y	Z	Refl.	DEN	Freq.	Lw	l/a	Optime	K0	Di	Adiv	Aatm	Agr	Afol	Ahous	Abar	Cmet	RL	Lr
	(m)	(m)	(m)			(Hz)	dB(A)	dB	dB	(dB)	(dB)	(dB)	(dB)	(dB)	(dB)	(dB)	(dB)	(dB)	(dB)	dB(A)
8463	340571.21	5028578.80	103.95	0	DEN	A	84.4	0.0	0.0	0.0	0.0	64.8	2.2	-1.8	0.0	0.0	5.0	0.0	0.0	14.3

Point Source, ISO 9613, Name: "Battery Energy Storage System 200", ID: "I0008!BESS200"																				
Nr.	X	Y	Z	Refl.	DEN	Freq.	Lw	l/a	Optime	K0	Di	Adiv	Aatm	Agr	Afol	Ahous	Abar	Cmet	RL	Lr
	(m)	(m)	(m)			(Hz)	dB(A)	dB	dB	(dB)	(dB)	(dB)	(dB)	(dB)	(dB)	(dB)	(dB)	(dB)	(dB)	dB(A)
8486	340433.98	5028596.79	103.95	0	DEN	A	84.4	0.0	0.0	0.0	0.0	64.8	2.2	-1.2	0.0	0.0	13.6	0.0	0.0	5.1
8487	340433.98	5028596.79	103.95	1	DEN	A	84.4	0.0	0.0	0.0	0.0	65.8	2.4	-1.9	0.0	0.0	4.8	0.0	12.7	0.5

Point Source, ISO 9613, Name: "Medium Voltage Substation 049", ID: "I02!MVT049"																				
Nr.	X	Y	Z	Refl.	DEN	Freq.	Lw	l/a	Optime	K0	Di	Adiv	Aatm	Agr	Afol	Ahous	Abar	Cmet	RL	Lr
	(m)	(m)	(m)			(Hz)	dB(A)	dB	dB	(dB)	(dB)	(dB)	(dB)	(dB)	(dB)	(dB)	(dB)	(dB)	(dB)	dB(A)
8511	340407.83	5028599.68	103.20	0	DEN	A	84.5	0.0	0.0	0.0	0.0	64.8	1.5	-1.1	0.0	0.0	5.3	0.0	0.0	13.9
8512	340407.83	5028599.68	103.20	1	DEN	A	84.5	0.0	0.0	0.0	0.0	65.6	1.7	-1.4	0.0	0.0	5.2	0.0	7.9	5.6
8519	340407.83	5028599.68	103.20	1	DEN	A	84.5	0.0	0.0	0.0	0.0	65.1	1.6	-1.3	0.0	0.0	5.1	0.0	6.6	7.5

Point Source, ISO 9613, Name: "Battery Energy Storage System 197", ID: "I0008!BESS197"																				
Nr.	X	Y	Z	Refl.	DEN	Freq.	Lw	l/a	Optime	K0	Di	Adiv	Aatm	Agr	Afol	Ahous	Abar	Cmet	RL	Lr
	(m)	(m)	(m)			(Hz)	dB(A)	dB	dB	(dB)	(dB)	(dB)	(dB)	(dB)	(dB)	(dB)	(dB)	(dB)	(dB)	dB(A)
8526	340425.52	5028598.20	103.95	0	DEN	A	84.4	0.0	0.0	0.0	0.0	64.8	2.2	-1.2	0.0	0.0	10.5	0.0	0.0	8.2
8528	340425.52	5028598.20	103.95	1	DEN	A	84.4	0.0	0.0	0.0	0.0	65.8	2.4	-1.8	0.0	0.0	4.8	0.0	3.8	9.6

Point Source, ISO 9613, Name: "Battery Energy Storage System 076", ID: "I0003!BESS076"																				
Nr.	X	Y	Z	Refl.	DEN	Freq.	Lw	l/a	Optime	K0	Di	Adiv	Aatm	Agr	Afol	Ahous	Abar	Cmet	RL	Lr
	(m)	(m)	(m)			(Hz)	dB(A)	dB	dB	(dB)	(dB)	(dB)	(dB)	(dB)	(dB)	(dB)	(dB)	(dB)	(dB)	dB(A)
8555	340638.22	5028582.64	103.95	0	DEN	A	84.4	0.0	0.0	0.0	0.0	64.8	2.2	-1.8	0.0	0.0	5.2	0.0	0.0	14.1
8556	340638.22	5028582.64	103.95	1	DEN	A	84.4	0.0	0.0	0.0	0.0	65.1	2.2	-1.8	0.0	0.0	4.8	0.0	3.7	10.4

Point Source, ISO 9613, Name: "Battery Energy Storage System 107", ID: "I0005!BESS107"																				
Nr.	X	Y	Z	Refl.	DEN	Freq.	Lw	l/a	Optime	K0	Di	Adiv	Aatm	Agr	Afol	Ahous	Abar	Cmet	RL	Lr
	(m)	(m)	(m)			(Hz)	dB(A)	dB	dB	(dB)	(dB)	(dB)	(dB)	(dB)	(dB)	(dB)	(dB)	(dB)	(dB)	dB(A)
8588	340579.66	5028577.38	103.95	0	DEN	A	84.4	0.0	0.0	0.0	0.0	64.8	2.2	-1.8	0.0	0.0	5.2	0.0	0.0	14.1

Sample Calculation at POR3 - Regular Operations

Point Source, ISO 9613, Name: "Battery Energy Storage System 184", ID: "I0007!BESS184"																				
Nr.	X	Y	Z	Refl.	DEN	Freq.	Lw	l/a	Optime	K0	Di	Adiv	Aatm	Agr	Afol	Ahous	Abar	Cmet	RL	Lr
	(m)	(m)	(m)			(Hz)	dB(A)	dB	dB	(dB)	(dB)	(dB)	(dB)	(dB)	(dB)	(dB)	(dB)	(dB)	(dB)	dB(A)
8609	340490.76	5028582.57	103.95	0	DEN	A	84.4	0.0	0.0	0.0	0.0	64.8	2.2	-2.0	0.0	0.0	4.9	0.0	0.0	14.6
8620	340490.76	5028582.57	103.95	1	DEN	A	84.4	0.0	0.0	0.0	0.0	65.2	2.2	-2.0	0.0	0.0	4.8	0.0	2.5	11.6

Point Source, ISO 9613, Name: "Battery Energy Storage System 118", ID: "I0004!BESS118"																				
Nr.	X	Y	Z	Refl.	DEN	Freq.	Lw	l/a	Optime	K0	Di	Adiv	Aatm	Agr	Afol	Ahous	Abar	Cmet	RL	Lr
	(m)	(m)	(m)			(Hz)	dB(A)	dB	dB	(dB)	(dB)	(dB)	(dB)	(dB)	(dB)	(dB)	(dB)	(dB)	(dB)	dB(A)
8646	340608.03	5028578.40	103.95	0	DEN	A	84.4	0.0	0.0	0.0	0.0	64.8	2.2	-1.7	0.0	0.0	10.3	0.0	0.0	8.9

Point Source, ISO 9613, Name: "Battery Energy Storage System 187", ID: "I0007!BESS187"																				
Nr.	X	Y	Z	Refl.	DEN	Freq.	Lw	l/a	Optime	K0	Di	Adiv	Aatm	Agr	Afol	Ahous	Abar	Cmet	RL	Lr
	(m)	(m)	(m)			(Hz)	dB(A)	dB	dB	(dB)	(dB)	(dB)	(dB)	(dB)	(dB)	(dB)	(dB)	(dB)	(dB)	dB(A)
8669	340499.22	5028581.15	103.95	0	DEN	A	84.4	0.0	0.0	0.0	0.0	64.8	2.2	-1.9	0.0	0.0	4.8	0.0	0.0	14.6
8681	340499.22	5028581.15	103.95	1	DEN	A	84.4	0.0	0.0	0.0	0.0	65.3	2.3	-2.0	0.0	0.0	4.8	0.0	3.7	10.4
8694	340499.22	5028581.15	103.95	1	DEN	A	84.4	0.0	0.0	0.0	0.0	65.2	2.2	-1.8	0.0	0.0	0.0	0.0	12.4	6.4

Point Source, ISO 9613, Name: "Battery Energy Storage System 204", ID: "I0008!BESS204"																				
Nr.	X	Y	Z	Refl.	DEN	Freq.	Lw	l/a	Optime	K0	Di	Adiv	Aatm	Agr	Afol	Ahous	Abar	Cmet	RL	Lr
	(m)	(m)	(m)			(Hz)	dB(A)	dB	dB	(dB)	(dB)	(dB)	(dB)	(dB)	(dB)	(dB)	(dB)	(dB)	(dB)	dB(A)
8705	340440.99	5028592.82	103.95	0	DEN	A	84.4	0.0	0.0	0.0	0.0	64.8	2.2	-1.3	0.0	0.0	13.6	0.0	0.0	5.1
8706	340440.99	5028592.82	103.95	1	DEN	A	84.4	0.0	0.0	0.0	0.0	65.9	2.4	-1.8	0.0	0.0	4.8	0.0	12.7	0.5

Point Source, ISO 9613, Name: "Medium Voltage Substation 050", ID: "I02!MVT050"																				
Nr.	X	Y	Z	Refl.	DEN	Freq.	Lw	l/a	Optime	K0	Di	Adiv	Aatm	Agr	Afol	Ahous	Abar	Cmet	RL	Lr
	(m)	(m)	(m)			(Hz)	dB(A)	dB	dB	(dB)	(dB)	(dB)	(dB)	(dB)	(dB)	(dB)	(dB)	(dB)	(dB)	dB(A)
8737	340414.84	5028595.71	103.20	0	DEN	A	84.5	0.0	0.0	0.0	0.0	64.9	1.5	-1.2	0.0	0.0	8.0	0.0	0.0	11.2
8738	340414.84	5028595.71	103.20	1	DEN	A	84.5	0.0	0.0	0.0	0.0	65.6	1.7	-1.5	0.0	0.0	6.1	0.0	8.8	3.9
8760	340414.84	5028595.71	103.20	1	DEN	A	84.5	0.0	0.0	0.0	0.0	65.1	1.6	-1.4	0.0	0.0	5.1	0.0	6.6	7.5

Point Source, ISO 9613, Name: "Battery Energy Storage System 201", ID: "I0008!BESS201"																				
Nr.	X	Y	Z	Refl.	DEN	Freq.	Lw	l/a	Optime	K0	Di	Adiv	Aatm	Agr	Afol	Ahous	Abar	Cmet	RL	Lr
	(m)	(m)	(m)			(Hz)	dB(A)	dB	dB	(dB)	(dB)	(dB)	(dB)	(dB)	(dB)	(dB)	(dB)	(dB)	(dB)	dB(A)
8771	340432.53	5028594.23	103.95	0	DEN	A	84.4	0.0	0.0	0.0	0.0	64.8	2.2	-1.2	0.0	0.0	10.5	0.0	0.0	8.2
8773	340432.53	5028594.23	103.95	1	DEN	A	84.4	0.0	0.0	0.0	0.0	65.8	2.4	-1.8	0.0	0.0	4.8	0.0	3.8	9.5

Point Source, ISO 9613, Name: "Medium Voltage Substation 031", ID: "I02!MVT031"																				
Nr.	X	Y	Z	Refl.	DEN	Freq.	Lw	l/a	Optime	K0	Di	Adiv	Aatm	Agr	Afol	Ahous	Abar	Cmet	RL	Lr
	(m)	(m)	(m)			(Hz)	dB(A)	dB	dB	(dB)	(dB)	(dB)	(dB)	(dB)	(dB)	(dB)	(dB)	(dB)	(dB)	dB(A)
8799	340603.76	5028571.93	103.20	0	DEN	A	84.5	0.0	0.0	0.0	0.0	64.9	1.6	-1.6	0.0	0.0	7.9	0.0	0.0	11.8

Point Source, ISO 9613, Name: "Battery Energy Storage System 108", ID: "I0005!BESS108"																				
Nr.	X	Y	Z	Refl.	DEN	Freq.	Lw	l/a	Optime	K0	Di	Adiv	Aatm	Agr	Afol	Ahous	Abar	Cmet	RL	Lr
	(m)	(m)	(m)			(Hz)	dB(A)	dB	dB	(dB)	(dB)	(dB)	(dB)	(dB)	(dB)	(dB)	(dB)	(dB)	(dB)	dB(A)
8823	340578.22	5028574.83	103.95	0	DEN	A	84.4	0.0	0.0	0.0	0.0	64.8	2.2	-1.8	0.0	0.0	5.0	0.0	0.0	14.3

Point Source, ISO 9613, Name: "Medium Voltage Substation 051", ID: "I02!MVT051"																				
Nr.	X	Y	Z	Refl.	DEN	Freq.	Lw	l/a	Optime	K0	Di	Adiv	Aatm	Agr	Afol	Ahous	Abar	Cmet	RL	Lr
	(m)	(m)	(m)			(Hz)	dB(A)	dB	dB	(dB)	(dB)	(dB)	(dB)	(dB)	(dB)	(dB)	(dB)	(dB)	(dB)	dB(A)
8851	340421.85	5028591.73	103.20	0	DEN	A	84.5	0.0	0.0	0.0	0.0	64.9	1.6	-1.3	0.0	0.0	8.1	0.0	0.0	11.2
8852	340421.85	5028591.73	103.20	1	DEN	A	84.5	0.0	0.0	0.0	0.0	65.6	1.7	-1.5	0.0	0.0	6.2	0.0	8.8	3.7
8866	340421.85	5028591.73	103.20	1	DEN	A	84.5	0.0	0.0	0.0	0.0	65.1	1.6	-1.4	0.0	0.0	5.7	0.0	7.3	6.3

Point Source, ISO 9613, Name: "Battery Energy Storage System 079", ID: "I0003!BESS079"																				
Nr.	X	Y	Z	Refl.	DEN	Freq.	Lw	l/a	Optime	K0	Di	Adiv	Aatm	Agr	Afol	Ahous	Abar	Cmet	RL	Lr
	(m)	(m)	(m)			(Hz)	dB(A)	dB	dB	(dB)	(dB)	(dB)	(dB)	(dB)	(dB)	(dB)	(dB)	(dB)	(dB)	dB(A)
8882	340646.68	5028581.22	103.95	0	DEN	A	84.4	0.0	0.0	0.0	0.0	64.8	2.2	-1.8	0.0	0.0	5.4	0.0	0.0	13.8
8883	340646.68	5028581.22	103.95	1	DEN	A	84.4	0.0	0.0	0.0	0.0	65.2	2.3	-1.9	0.0	0.0	4.8	0.0	3.7	10.3

Point Source, ISO 9613, Name: "Battery Energy Storage System 208", ID: "I0008!BESS208"																				
Nr.	X	Y	Z	Refl.	DEN	Freq.	Lw	l/a	Optime	K0	Di	Adiv	Aatm	Agr	Afol	Ahous	Abar	Cmet	RL	Lr
	(m)	(m)	(m)			(Hz)	dB(A)	dB	dB	(dB)	(dB)	(dB)	(dB)	(dB)	(dB)	(dB)	(dB)	(dB)	(dB)	dB(A)
8905	340448.00	5028588.84	103.95	0	DEN	A	84.4	0.0	0.0	0.0	0.0	64.8	2.2	-1.6	0.0	0.0	13.6	0.0	0.0	5.4
8906	340448.00	5028588.84	103.95	1	DEN	A	84.4	0.0	0.0	0.0	0.0	65.9	2.4	-1.8	0.0	0.0	4.8	0.0	12.8	0.4

Sample Calculation at POR3 - Regular Operations

Point Source, ISO 9613, Name: "Battery Energy Storage System 121", ID: "I0004!BESS121"																				
Nr.	X	Y	Z	Refl.	DEN	Freq.	Lw	l/a	Optime	K0	Di	Adiv	Aatm	Agr	Afol	Ahous	Abar	Cmet	RL	Lr
	(m)	(m)	(m)			(Hz)	dB(A)	dB	dB	(dB)	(dB)	(dB)	(dB)	(dB)	(dB)	(dB)	(dB)	(dB)	(dB)	dB(A)
8929	340616.49	5028576.98	103.95	0	DEN	A	84.4	0.0	0.0	0.0	0.0	64.8	2.2	-1.7	0.0	0.0	13.4	0.0	0.0	5.7

Point Source, ISO 9613, Name: "Battery Energy Storage System 188", ID: "I0007!BESS188"																				
Nr.	X	Y	Z	Refl.	DEN	Freq.	Lw	l/a	Optime	K0	Di	Adiv	Aatm	Agr	Afol	Ahous	Abar	Cmet	RL	Lr
	(m)	(m)	(m)			(Hz)	dB(A)	dB	dB	(dB)	(dB)	(dB)	(dB)	(dB)	(dB)	(dB)	(dB)	(dB)	(dB)	dB(A)
8948	340497.77	5028578.59	103.95	0	DEN	A	84.4	0.0	0.0	0.0	0.0	64.8	2.2	-2.0	0.0	0.0	4.7	0.0	0.0	14.6
8963	340497.77	5028578.59	103.95	1	DEN	A	84.4	0.0	0.0	0.0	0.0	65.2	2.3	-2.0	0.0	0.0	4.8	0.0	2.5	11.6
8976	340497.77	5028578.59	103.95	1	DEN	A	84.4	0.0	0.0	0.0	0.0	65.2	2.2	-1.9	0.0	0.0	0.0	0.0	12.5	6.3

Point Source, ISO 9613, Name: "Battery Energy Storage System 205", ID: "I0008!BESS205"																				
Nr.	X	Y	Z	Refl.	DEN	Freq.	Lw	l/a	Optime	K0	Di	Adiv	Aatm	Agr	Afol	Ahous	Abar	Cmet	RL	Lr
	(m)	(m)	(m)			(Hz)	dB(A)	dB	dB	(dB)	(dB)	(dB)	(dB)	(dB)	(dB)	(dB)	(dB)	(dB)	(dB)	dB(A)
8992	340439.54	5028590.26	103.95	0	DEN	A	84.4	0.0	0.0	0.0	0.0	64.8	2.2	-1.3	0.0	0.0	10.5	0.0	0.0	8.2
8993	340439.54	5028590.26	103.95	1	DEN	A	84.4	0.0	0.0	0.0	0.0	65.8	2.4	-1.8	0.0	0.0	4.8	0.0	3.8	9.5

Point Source, ISO 9613, Name: "Battery Energy Storage System 111", ID: "I0005!BESS111"																				
Nr.	X	Y	Z	Refl.	DEN	Freq.	Lw	l/a	Optime	K0	Di	Adiv	Aatm	Agr	Afol	Ahous	Abar	Cmet	RL	Lr
	(m)	(m)	(m)			(Hz)	dB(A)	dB	dB	(dB)	(dB)	(dB)	(dB)	(dB)	(dB)	(dB)	(dB)	(dB)	(dB)	dB(A)
9028	340586.67	5028573.41	103.95	0	DEN	A	84.4	0.0	0.0	0.0	0.0	64.9	2.2	-1.8	0.0	0.0	5.1	0.0	0.0	14.1

Point Source, ISO 9613, Name: "Medium Voltage Substation 052", ID: "I02!MVT052"																				
Nr.	X	Y	Z	Refl.	DEN	Freq.	Lw	l/a	Optime	K0	Di	Adiv	Aatm	Agr	Afol	Ahous	Abar	Cmet	RL	Lr
	(m)	(m)	(m)			(Hz)	dB(A)	dB	dB	(dB)	(dB)	(dB)	(dB)	(dB)	(dB)	(dB)	(dB)	(dB)	(dB)	dB(A)
9056	340428.86	5028587.76	103.20	0	DEN	A	84.5	0.0	0.0	0.0	0.0	64.9	1.6	-1.2	0.0	0.0	8.2	0.0	0.0	11.0
9057	340428.86	5028587.76	103.20	1	DEN	A	84.5	0.0	0.0	0.0	0.0	65.7	1.7	-1.5	0.0	0.0	6.2	0.0	8.8	3.7
9081	340428.86	5028587.76	103.20	1	DEN	A	84.5	0.0	0.0	0.0	0.0	65.1	1.6	-1.4	0.0	0.0	5.7	0.0	7.3	6.3

Point Source, ISO 9613, Name: "Battery Energy Storage System 080", ID: "I0003!BESS080"																				
Nr.	X	Y	Z	Refl.	DEN	Freq.	Lw	l/a	Optime	K0	Di	Adiv	Aatm	Agr	Afol	Ahous	Abar	Cmet	RL	Lr
	(m)	(m)	(m)			(Hz)	dB(A)	dB	dB	(dB)	(dB)	(dB)	(dB)	(dB)	(dB)	(dB)	(dB)	(dB)	(dB)	dB(A)
9095	340645.23	5028578.66	103.95	0	DEN	A	84.4	0.0	0.0	0.0	0.0	64.9	2.2	-1.8	0.0	0.0	5.2	0.0	0.0	14.0
9096	340645.23	5028578.66	103.95	1	DEN	A	84.4	0.0	0.0	0.0	0.0	65.2	2.2	-1.9	0.0	0.0	4.8	0.0	3.7	10.3

Point Source, ISO 9613, Name: "Battery Energy Storage System 212", ID: "I0008!BESS212"																				
Nr.	X	Y	Z	Refl.	DEN	Freq.	Lw	l/a	Optime	K0	Di	Adiv	Aatm	Agr	Afol	Ahous	Abar	Cmet	RL	Lr
	(m)	(m)	(m)			(Hz)	dB(A)	dB	dB	(dB)	(dB)	(dB)	(dB)	(dB)	(dB)	(dB)	(dB)	(dB)	(dB)	dB(A)
9130	340455.01	5028584.87	103.95	0	DEN	A	84.4	0.0	0.0	0.0	0.0	64.9	2.2	-1.7	0.0	0.0	13.6	0.0	0.0	5.4
9131	340455.01	5028584.87	103.95	1	DEN	A	84.4	0.0	0.0	0.0	0.0	65.9	2.4	-1.9	0.0	0.0	4.8	0.0	12.8	0.4

Point Source, ISO 9613, Name: "Battery Energy Storage System 122", ID: "I0004!BESS122"																				
Nr.	X	Y	Z	Refl.	DEN	Freq.	Lw	l/a	Optime	K0	Di	Adiv	Aatm	Agr	Afol	Ahous	Abar	Cmet	RL	Lr
	(m)	(m)	(m)			(Hz)	dB(A)	dB	dB	(dB)	(dB)	(dB)	(dB)	(dB)	(dB)	(dB)	(dB)	(dB)	(dB)	dB(A)
9169	340615.04	5028574.43	103.95	0	DEN	A	84.4	0.0	0.0	0.0	0.0	64.9	2.2	-1.8	0.0	0.0	10.3	0.0	0.0	8.8

Point Source, ISO 9613, Name: "Battery Energy Storage System 209", ID: "I0008!BESS209"																				
Nr.	X	Y	Z	Refl.	DEN	Freq.	Lw	l/a	Optime	K0	Di	Adiv	Aatm	Agr	Afol	Ahous	Abar	Cmet	RL	Lr
	(m)	(m)	(m)			(Hz)	dB(A)	dB	dB	(dB)	(dB)	(dB)	(dB)	(dB)	(dB)	(dB)	(dB)	(dB)	(dB)	dB(A)
9194	340446.55	5028586.28	103.95	0	DEN	A	84.4	0.0	0.0	0.0	0.0	64.9	2.2	-1.6	0.0	0.0	10.5	0.0	0.0	8.4
9196	340446.55	5028586.28	103.95	1	DEN	A	84.4	0.0	0.0	0.0	0.0	65.8	2.4	-1.8	0.0	0.0	4.8	0.0	3.8	9.5

Point Source, ISO 9613, Name: "Medium Voltage Substation 053", ID: "I02!MVT053"																				
Nr.	X	Y	Z	Refl.	DEN	Freq.	Lw	l/a	Optime	K0	Di	Adiv	Aatm	Agr	Afol	Ahous	Abar	Cmet	RL	Lr
	(m)	(m)	(m)			(Hz)	dB(A)	dB	dB	(dB)	(dB)	(dB)	(dB)	(dB)	(dB)	(dB)	(dB)	(dB)	(dB)	dB(A)
9226	340435.87	5028583.79	103.20	0	DEN	A	84.5	0.0	0.0	0.0	0.0	65.0	1.6	-1.2	0.0	0.0	8.1	0.0	0.0	11.0
9230	340435.87	5028583.79	103.20	1	DEN	A	84.5	0.0	0.0	0.0	0.0	65.7	1.7	-1.5	0.0	0.0	6.2	0.0	8.8	3.7
9248	340435.87	5028583.79	103.20	1	DEN	A	84.5	0.0	0.0	0.0	0.0	65.2	1.6	-1.4	0.0	0.0	5.6	0.0	7.2	6.2

Point Source, ISO 9613, Name: "Battery Energy Storage System 112", ID: "I0005!BESS112"																				
Nr.	X	Y	Z	Refl.	DEN	Freq.	Lw	l/a	Optime	K0	Di	Adiv	Aatm	Agr	Afol	Ahous	Abar	Cmet	RL	Lr
	(m)	(m)	(m)			(Hz)	dB(A)	dB	dB	(dB)	(dB)	(dB)	(dB)	(dB)	(dB)	(dB)	(dB)	(dB)	(dB)	dB(A)
9267	340585.22	5028570.85	103.95	0	DEN	A	84.4	0.0	0.0	0.0	0.0	64.9	2.2	-1.8	0.0	0.0	5.0	0.0	0.0	14.2

Sample Calculation at POR3 - Regular Operations

Point Source, ISO 9613, Name: "Medium Voltage Substation 032", ID: "I02!MVT032"																				
Nr.	X	Y	Z	Refl.	DEN	Freq.	Lw	l/a	Optime	K0	Di	Adiv	Aatm	Agr	Afol	Ahous	Abar	Cmet	RL	Lr
	(m)	(m)	(m)			(Hz)	dB(A)	dB	dB	(dB)	(dB)	(dB)	(dB)	(dB)	(dB)	(dB)	(dB)	(dB)	(dB)	dB(A)
9304	340610.77	5028567.96	103.20	0	DEN	A	84.5	0.0	0.0	0.0	0.0	65.0	1.6	-1.6	0.0	0.0	7.9	0.0	0.0	11.7

Point Source, ISO 9613, Name: "Battery Energy Storage System 216", ID: "I0008!BESS216"																				
Nr.	X	Y	Z	Refl.	DEN	Freq.	Lw	l/a	Optime	K0	Di	Adiv	Aatm	Agr	Afol	Ahous	Abar	Cmet	RL	Lr
	(m)	(m)	(m)			(Hz)	dB(A)	dB	dB	(dB)	(dB)	(dB)	(dB)	(dB)	(dB)	(dB)	(dB)	(dB)	(dB)	dB(A)
9324	340462.02	5028580.89	103.95	0	DEN	A	84.4	0.0	0.0	0.0	0.0	64.9	2.2	-1.8	0.0	0.0	13.6	0.0	0.0	5.4
9325	340462.02	5028580.89	103.95	1	DEN	A	84.4	0.0	0.0	0.0	0.0	66.0	2.4	-2.0	0.0	0.0	4.8	0.0	12.8	0.5

Point Source, ISO 9613, Name: "Battery Energy Storage System 125", ID: "I0004!BESS125"																				
Nr.	X	Y	Z	Refl.	DEN	Freq.	Lw	l/a	Optime	K0	Di	Adiv	Aatm	Agr	Afol	Ahous	Abar	Cmet	RL	Lr
	(m)	(m)	(m)			(Hz)	dB(A)	dB	dB	(dB)	(dB)	(dB)	(dB)	(dB)	(dB)	(dB)	(dB)	(dB)	(dB)	dB(A)
9355	340623.50	5028573.01	103.95	0	DEN	A	84.4	0.0	0.0	0.0	0.0	64.9	2.2	-1.8	0.0	0.0	13.4	0.0	0.0	5.7

Point Source, ISO 9613, Name: "Battery Energy Storage System 083", ID: "I0003!BESS083"																				
Nr.	X	Y	Z	Refl.	DEN	Freq.	Lw	l/a	Optime	K0	Di	Adiv	Aatm	Agr	Afol	Ahous	Abar	Cmet	RL	Lr
	(m)	(m)	(m)			(Hz)	dB(A)	dB	dB	(dB)	(dB)	(dB)	(dB)	(dB)	(dB)	(dB)	(dB)	(dB)	(dB)	dB(A)
9385	340653.69	5028577.24	103.95	0	DEN	A	84.4	0.0	0.0	0.0	0.0	64.9	2.2	-1.8	0.0	0.0	5.4	0.0	0.0	13.7
9386	340653.69	5028577.24	103.95	1	DEN	A	84.4	0.0	0.0	0.0	0.0	65.3	2.3	-1.9	0.0	0.0	4.8	0.0	3.7	10.2

Point Source, ISO 9613, Name: "Battery Energy Storage System 213", ID: "I0008!BESS213"																				
Nr.	X	Y	Z	Refl.	DEN	Freq.	Lw	l/a	Optime	K0	Di	Adiv	Aatm	Agr	Afol	Ahous	Abar	Cmet	RL	Lr
	(m)	(m)	(m)			(Hz)	dB(A)	dB	dB	(dB)	(dB)	(dB)	(dB)	(dB)	(dB)	(dB)	(dB)	(dB)	(dB)	dB(A)
9424	340453.56	5028582.31	103.95	0	DEN	A	84.4	0.0	0.0	0.0	0.0	64.9	2.2	-1.6	0.0	0.0	10.5	0.0	0.0	8.5
9426	340453.56	5028582.31	103.95	1	DEN	A	84.4	0.0	0.0	0.0	0.0	65.9	2.4	-1.9	0.0	0.0	4.8	0.0	3.8	9.5

Point Source, ISO 9613, Name: "Medium Voltage Substation 054", ID: "I02!MVT054"																				
Nr.	X	Y	Z	Refl.	DEN	Freq.	Lw	l/a	Optime	K0	Di	Adiv	Aatm	Agr	Afol	Ahous	Abar	Cmet	RL	Lr
	(m)	(m)	(m)			(Hz)	dB(A)	dB	dB	(dB)	(dB)	(dB)	(dB)	(dB)	(dB)	(dB)	(dB)	(dB)	(dB)	dB(A)
9468	340442.88	5028579.81	103.20	0	DEN	A	84.5	0.0	0.0	0.0	0.0	65.0	1.6	-1.4	0.0	0.0	8.1	0.0	0.0	11.2
9469	340442.88	5028579.81	103.20	1	DEN	A	84.5	0.0	0.0	0.0	0.0	65.7	1.7	-1.6	0.0	0.0	6.1	0.0	8.8	3.7
9485	340442.88	5028579.81	103.20	1	DEN	A	84.5	0.0	0.0	0.0	0.0	65.2	1.6	-1.5	0.0	0.0	5.6	0.0	7.2	6.3

Point Source, ISO 9613, Name: "Battery Energy Storage System 115", ID: "I0005!BESS115"																				
Nr.	X	Y	Z	Refl.	DEN	Freq.	Lw	l/a	Optime	K0	Di	Adiv	Aatm	Agr	Afol	Ahous	Abar	Cmet	RL	Lr
	(m)	(m)	(m)			(Hz)	dB(A)	dB	dB	(dB)	(dB)	(dB)	(dB)	(dB)	(dB)	(dB)	(dB)	(dB)	(dB)	dB(A)
9514	340593.68	5028569.43	103.95	0	DEN	A	84.4	0.0	0.0	0.0	0.0	64.9	2.2	-1.8	0.0	0.0	5.1	0.0	0.0	14.0

Point Source, ISO 9613, Name: "Battery Energy Storage System 220", ID: "I0008!BESS220"																				
Nr.	X	Y	Z	Refl.	DEN	Freq.	Lw	l/a	Optime	K0	Di	Adiv	Aatm	Agr	Afol	Ahous	Abar	Cmet	RL	Lr
	(m)	(m)	(m)			(Hz)	dB(A)	dB	dB	(dB)	(dB)	(dB)	(dB)	(dB)	(dB)	(dB)	(dB)	(dB)	(dB)	dB(A)
9543	340469.03	5028576.92	103.95	0	DEN	A	84.4	0.0	0.0	0.0	0.0	65.0	2.2	-1.8	0.0	0.0	13.6	0.0	0.0	5.5
9544	340469.03	5028576.92	103.95	1	DEN	A	84.4	0.0	0.0	0.0	0.0	66.0	2.4	-2.1	0.0	0.0	4.8	0.0	12.8	0.5

Point Source, ISO 9613, Name: "Battery Energy Storage System 126", ID: "I0004!BESS126"																				
Nr.	X	Y	Z	Refl.	DEN	Freq.	Lw	l/a	Optime	K0	Di	Adiv	Aatm	Agr	Afol	Ahous	Abar	Cmet	RL	Lr
	(m)	(m)	(m)			(Hz)	dB(A)	dB	dB	(dB)	(dB)	(dB)	(dB)	(dB)	(dB)	(dB)	(dB)	(dB)	(dB)	dB(A)
9583	340622.05	5028570.45	103.95	0	DEN	A	84.4	0.0	0.0	0.0	0.0	65.0	2.2	-1.8	0.0	0.0	10.2	0.0	0.0	8.8

Point Source, ISO 9613, Name: "Battery Energy Storage System 084", ID: "I0003!BESS084"																				
Nr.	X	Y	Z	Refl.	DEN	Freq.	Lw	l/a	Optime	K0	Di	Adiv	Aatm	Agr	Afol	Ahous	Abar	Cmet	RL	Lr
	(m)	(m)	(m)			(Hz)	dB(A)	dB	dB	(dB)	(dB)	(dB)	(dB)	(dB)	(dB)	(dB)	(dB)	(dB)	(dB)	dB(A)
9615	340652.24	5028574.69	103.95	0	DEN	A	84.4	0.0	0.0	0.0	0.0	65.0	2.2	-1.8	0.0	0.0	5.2	0.0	0.0	13.9
9618	340652.24	5028574.69	103.95	1	DEN	A	84.4	0.0	0.0	0.0	0.0	65.3	2.3	-1.9	0.0	0.0	4.8	0.0	3.7	10.3

Point Source, ISO 9613, Name: "Battery Energy Storage System 217", ID: "I0008!BESS217"																				
Nr.	X	Y	Z	Refl.	DEN	Freq.	Lw	l/a	Optime	K0	Di	Adiv	Aatm	Agr	Afol	Ahous	Abar	Cmet	RL	Lr
	(m)	(m)	(m)			(Hz)	dB(A)	dB	dB	(dB)	(dB)	(dB)	(dB)	(dB)	(dB)	(dB)	(dB)	(dB)	(dB)	dB(A)
9642	340460.57	5028578.33	103.95	0	DEN	A	84.4	0.0	0.0	0.0	0.0	65.0	2.2	-1.8	0.0	0.0	10.5	0.0	0.0	8.6
9643	340460.57	5028578.33	103.95	1	DEN	A	84.4	0.0	0.0	0.0	0.0	65.9	2.4	-1.9	0.0	0.0	4.8	0.0	3.8	9.5

Point Source, ISO 9613, Name: "Medium Voltage Substation 055", ID: "I02!MVT055"																				
Nr.	X	Y	Z	Refl.	DEN	Freq.	Lw	l/a	Optime	K0	Di	Adiv	Aatm	Agr	Afol	Ahous	Abar	Cmet	RL	Lr
	(m)	(m)	(m)			(Hz)	dB(A)	dB	dB	(dB)	(dB)	(dB)	(dB)	(dB)	(dB)	(dB)	(dB)	(dB)	(dB)	dB(A)
9687	340449.89	5028575.84	103.20	0	DEN	A	84.5	0.0	0.0	0.0	0.0	65.0	1.6	-1.5	0.0	0.0	8.1	0.0	0.0	11.3

Sample Calculation at POR3 - Regular Operations

Point Source, ISO 9613, Name: "Medium Voltage Substation 055", ID: "I02!MVT055"																				
Nr.	X	Y	Z	Refl.	DEN	Freq.	Lw	l/a	Optime	K0	Di	Adiv	Aatm	Agr	Afol	Ahous	Abar	Cmet	RL	Lr
	(m)	(m)	(m)			(Hz)	dB(A)	dB	dB	(dB)	(dB)	(dB)	(dB)	(dB)	(dB)	(dB)	(dB)	(dB)	(dB)	dB(A)
9689	340449.89	5028575.84	103.20	1	DEN	A	84.5	0.0	0.0	0.0	0.0	65.8	1.7	-1.6	0.0	0.0	6.1	0.0	8.8	3.7
9715	340449.89	5028575.84	103.20	1	DEN	A	84.5	0.0	0.0	0.0	0.0	65.2	1.6	-1.6	0.0	0.0	5.6	0.0	7.2	6.4

Point Source, ISO 9613, Name: "Battery Energy Storage System 190", ID: "I0009!BESS190"																				
Nr.	X	Y	Z	Refl.	DEN	Freq.	Lw	l/a	Optime	K0	Di	Adiv	Aatm	Agr	Afol	Ahous	Abar	Cmet	RL	Lr
	(m)	(m)	(m)			(Hz)	dB(A)	dB	dB	(dB)	(dB)	(dB)	(dB)	(dB)	(dB)	(dB)	(dB)	(dB)	(dB)	dB(A)
9737	340404.17	5028593.21	103.95	0	DEN	A	84.4	0.0	0.0	0.0	0.0	65.0	2.2	-1.4	0.0	0.0	2.6	0.0	0.0	16.0
9739	340404.17	5028593.21	103.95	1	DEN	A	84.4	0.0	0.0	0.0	0.0	65.5	2.3	-1.7	0.0	0.0	0.0	0.0	3.7	14.6

Point Source, ISO 9613, Name: "Battery Energy Storage System 116", ID: "I0005!BESS116"																				
Nr.	X	Y	Z	Refl.	DEN	Freq.	Lw	l/a	Optime	K0	Di	Adiv	Aatm	Agr	Afol	Ahous	Abar	Cmet	RL	Lr
	(m)	(m)	(m)			(Hz)	dB(A)	dB	dB	(dB)	(dB)	(dB)	(dB)	(dB)	(dB)	(dB)	(dB)	(dB)	(dB)	dB(A)
9759	340592.23	5028566.88	103.95	0	DEN	A	84.4	0.0	0.0	0.0	0.0	65.0	2.2	-1.8	0.0	0.0	5.0	0.0	0.0	14.1

Point Source, ISO 9613, Name: "Medium Voltage Substation 033", ID: "I02!MVT033"																				
Nr.	X	Y	Z	Refl.	DEN	Freq.	Lw	l/a	Optime	K0	Di	Adiv	Aatm	Agr	Afol	Ahous	Abar	Cmet	RL	Lr
	(m)	(m)	(m)			(Hz)	dB(A)	dB	dB	(dB)	(dB)	(dB)	(dB)	(dB)	(dB)	(dB)	(dB)	(dB)	(dB)	dB(A)
9790	340617.78	5028563.98	103.20	0	DEN	A	84.5	0.0	0.0	0.0	0.0	65.1	1.6	-1.6	0.0	0.0	7.8	0.0	0.0	11.6

Point Source, ISO 9613, Name: "Battery Energy Storage System 129", ID: "I0004!BESS129"																				
Nr.	X	Y	Z	Refl.	DEN	Freq.	Lw	l/a	Optime	K0	Di	Adiv	Aatm	Agr	Afol	Ahous	Abar	Cmet	RL	Lr
	(m)	(m)	(m)			(Hz)	dB(A)	dB	dB	(dB)	(dB)	(dB)	(dB)	(dB)	(dB)	(dB)	(dB)	(dB)	(dB)	dB(A)
9830	340630.51	5028569.03	103.95	0	DEN	A	84.4	0.0	0.0	0.0	0.0	65.0	2.2	-1.8	0.0	0.0	13.3	0.0	0.0	5.7

Point Source, ISO 9613, Name: "Battery Energy Storage System 224", ID: "I0008!BESS224"																				
Nr.	X	Y	Z	Refl.	DEN	Freq.	Lw	l/a	Optime	K0	Di	Adiv	Aatm	Agr	Afol	Ahous	Abar	Cmet	RL	Lr
	(m)	(m)	(m)			(Hz)	dB(A)	dB	dB	(dB)	(dB)	(dB)	(dB)	(dB)	(dB)	(dB)	(dB)	(dB)	(dB)	dB(A)
9857	340476.04	5028572.94	103.95	0	DEN	A	84.4	0.0	0.0	0.0	0.0	65.0	2.2	-1.9	0.0	0.0	13.6	0.0	0.0	5.5
9858	340476.04	5028572.94	103.95	1	DEN	A	84.4	0.0	0.0	0.0	0.0	66.0	2.4	-2.2	0.0	0.0	4.8	0.0	12.8	0.5

Point Source, ISO 9613, Name: "Battery Energy Storage System 194", ID: "I0009!BESS194"																				
Nr.	X	Y	Z	Refl.	DEN	Freq.	Lw	l/a	Optime	K0	Di	Adiv	Aatm	Agr	Afol	Ahous	Abar	Cmet	RL	Lr
	(m)	(m)	(m)			(Hz)	dB(A)	dB	dB	(dB)	(dB)	(dB)	(dB)	(dB)	(dB)	(dB)	(dB)	(dB)	(dB)	dB(A)
9911	340411.18	5028589.24	103.95	0	DEN	A	84.4	0.0	0.0	0.0	0.0	65.0	2.2	-1.4	0.0	0.0	5.1	0.0	0.0	13.6
9913	340411.18	5028589.24	103.95	1	DEN	A	84.4	0.0	0.0	0.0	0.0	65.5	2.3	-1.7	0.0	0.0	4.8	0.0	3.7	9.8

Point Source, ISO 9613, Name: "Battery Energy Storage System 221", ID: "I0008!BESS221"																				
Nr.	X	Y	Z	Refl.	DEN	Freq.	Lw	l/a	Optime	K0	Di	Adiv	Aatm	Agr	Afol	Ahous	Abar	Cmet	RL	Lr
	(m)	(m)	(m)			(Hz)	dB(A)	dB	dB	(dB)	(dB)	(dB)	(dB)	(dB)	(dB)	(dB)	(dB)	(dB)	(dB)	dB(A)
9933	340467.58	5028574.36	103.95	0	DEN	A	84.4	0.0	0.0	0.0	0.0	65.0	2.2	-1.8	0.0	0.0	10.4	0.0	0.0	8.6
9934	340467.58	5028574.36	103.95	1	DEN	A	84.4	0.0	0.0	0.0	0.0	65.9	2.4	-2.0	0.0	0.0	4.8	0.0	3.8	9.6

Point Source, ISO 9613, Name: "Medium Voltage Substation 056", ID: "I02!MVT056"																				
Nr.	X	Y	Z	Refl.	DEN	Freq.	Lw	l/a	Optime	K0	Di	Adiv	Aatm	Agr	Afol	Ahous	Abar	Cmet	RL	Lr
	(m)	(m)	(m)			(Hz)	dB(A)	dB	dB	(dB)	(dB)	(dB)	(dB)	(dB)	(dB)	(dB)	(dB)	(dB)	(dB)	dB(A)
9972	340456.90	5028571.86	103.20	0	DEN	A	84.5	0.0	0.0	0.0	0.0	65.1	1.6	-1.6	0.0	0.0	8.0	0.0	0.0	11.4
9973	340456.90	5028571.86	103.20	1	DEN	A	84.5	0.0	0.0	0.0	0.0	65.8	1.7	-1.7	0.0	0.0	6.1	0.0	8.7	3.8
9998	340456.90	5028571.86	103.20	1	DEN	A	84.5	0.0	0.0	0.0	0.0	65.3	1.6	-1.7	0.0	0.0	5.6	0.0	7.2	6.5

Point Source, ISO 9613, Name: "Battery Energy Storage System 119", ID: "I0005!BESS119"																				
Nr.	X	Y	Z	Refl.	DEN	Freq.	Lw	l/a	Optime	K0	Di	Adiv	Aatm	Agr	Afol	Ahous	Abar	Cmet	RL	Lr
	(m)	(m)	(m)			(Hz)	dB(A)	dB	dB	(dB)	(dB)	(dB)	(dB)	(dB)	(dB)	(dB)	(dB)	(dB)	(dB)	dB(A)
0022	340600.69	5028565.46	103.95	0	DEN	A	84.4	0.0	0.0	0.0	0.0	65.0	2.2	-1.8	0.0	0.0	5.3	0.0	0.0	13.7

Point Source, ISO 9613, Name: "Battery Energy Storage System 191", ID: "I0009!BESS191"																				
Nr.	X	Y	Z	Refl.	DEN	Freq.	Lw	l/a	Optime	K0	Di	Adiv	Aatm	Agr	Afol	Ahous	Abar	Cmet	RL	Lr
	(m)	(m)	(m)			(Hz)	dB(A)	dB	dB	(dB)	(dB)	(dB)	(dB)	(dB)	(dB)	(dB)	(dB)	(dB)	(dB)	dB(A)
0047	340402.72	5028590.66	103.95	0	DEN	A	84.4	0.0	0.0	0.0	0.0	65.0	2.2	-1.5	0.0	0.0	2.1	0.0	0.0	16.6
0049	340402.72	5028590.66	103.95	1	DEN	A	84.4	0.0	0.0	0.0	0.0	65.4	2.3	-1.7	0.0	0.0	0.0	0.0	2.6	15.8

Point Source, ISO 9613, Name: "Battery Energy Storage System 198", ID: "I0009!BESS198"																				
Nr.	X	Y	Z	Refl.	DEN	Freq.	Lw	l/a	Optime	K0	Di	Adiv	Aatm	Agr	Afol	Ahous	Abar	Cmet	RL	Lr
	(m)	(m)	(m)			(Hz)	dB(A)	dB	dB	(dB)	(dB)	(dB)	(dB)	(dB)	(dB)	(dB)	(dB)	(dB)	(dB)	dB(A)
0073	340418.19	5028585.26	103.95	0	DEN	A	84.4	0.0	0.0	0.0	0.0	65.0	2.2	-1.4	0.0	0.0	5.3	0.0	0.0	13.3

Sample Calculation at POR3 - Regular Operations

Point Source, ISO 9613, Name: "Battery Energy Storage System 198", ID: "I0009!BESS198"																				
Nr.	X	Y	Z	Refl.	DEN	Freq.	Lw	l/a	Optime	K0	Di	Adiv	Aatm	Agr	Afol	Ahous	Abar	Cmet	RL	Lr
	(m)	(m)	(m)			(Hz)	dB(A)	dB	dB	(dB)	(dB)	(dB)	(dB)	(dB)	(dB)	(dB)	(dB)	(dB)	(dB)	dB(A)
0074	340418.19	5028585.26	103.95	1	DEN	A	84.4	0.0	0.0	0.0	0.0	65.5	2.3	-1.8	0.0	0.0	4.8	0.0	3.8	9.8

Point Source, ISO 9613, Name: "Battery Energy Storage System 130", ID: "I0004!BESS130"																				
Nr.	X	Y	Z	Refl.	DEN	Freq.	Lw	l/a	Optime	K0	Di	Adiv	Aatm	Agr	Afol	Ahous	Abar	Cmet	RL	Lr
	(m)	(m)	(m)			(Hz)	dB(A)	dB	dB	(dB)	(dB)	(dB)	(dB)	(dB)	(dB)	(dB)	(dB)	(dB)	(dB)	dB(A)
0103	340629.06	5028566.48	103.95	0	DEN	A	84.4	0.0	0.0	0.0	0.0	65.0	2.2	-1.9	0.0	0.0	10.2	0.0	0.0	8.8

Point Source, ISO 9613, Name: "Battery Energy Storage System 228", ID: "I0008!BESS228"																				
Nr.	X	Y	Z	Refl.	DEN	Freq.	Lw	l/a	Optime	K0	Di	Adiv	Aatm	Agr	Afol	Ahous	Abar	Cmet	RL	Lr
	(m)	(m)	(m)			(Hz)	dB(A)	dB	dB	(dB)	(dB)	(dB)	(dB)	(dB)	(dB)	(dB)	(dB)	(dB)	(dB)	dB(A)
0138	340483.05	5028568.97	103.95	0	DEN	A	84.4	0.0	0.0	0.0	0.0	65.0	2.2	-2.0	0.0	0.0	13.6	0.0	0.0	5.6
0139	340483.05	5028568.97	103.95	1	DEN	A	84.4	0.0	0.0	0.0	0.0	66.1	2.4	-2.2	0.0	0.0	4.8	0.0	12.8	0.5

Point Source, ISO 9613, Name: "Battery Energy Storage System 225", ID: "I0008!BESS225"																				
Nr.	X	Y	Z	Refl.	DEN	Freq.	Lw	l/a	Optime	K0	Di	Adiv	Aatm	Agr	Afol	Ahous	Abar	Cmet	RL	Lr
	(m)	(m)	(m)			(Hz)	dB(A)	dB	dB	(dB)	(dB)	(dB)	(dB)	(dB)	(dB)	(dB)	(dB)	(dB)	(dB)	dB(A)
0171	340474.59	5028570.38	103.95	0	DEN	A	84.4	0.0	0.0	0.0	0.0	65.0	2.2	-1.9	0.0	0.0	10.4	0.0	0.0	8.7
0172	340474.59	5028570.38	103.95	1	DEN	A	84.4	0.0	0.0	0.0	0.0	66.0	2.4	-2.1	0.0	0.0	4.8	0.0	12.8	0.6

Point Source, ISO 9613, Name: "Medium Voltage Substation 057", ID: "I02!MVT057"																				
Nr.	X	Y	Z	Refl.	DEN	Freq.	Lw	l/a	Optime	K0	Di	Adiv	Aatm	Agr	Afol	Ahous	Abar	Cmet	RL	Lr
	(m)	(m)	(m)			(Hz)	dB(A)	dB	dB	(dB)	(dB)	(dB)	(dB)	(dB)	(dB)	(dB)	(dB)	(dB)	(dB)	dB(A)
0211	340463.91	5028567.89	103.20	0	DEN	A	84.5	0.0	0.0	0.0	0.0	65.1	1.6	-1.6	0.0	0.0	8.0	0.0	0.0	11.4
0213	340463.91	5028567.89	103.20	1	DEN	A	84.5	0.0	0.0	0.0	0.0	65.8	1.7	-1.8	0.0	0.0	6.1	0.0	8.8	3.9
0240	340463.91	5028567.89	103.20	1	DEN	A	84.5	0.0	0.0	0.0	0.0	65.3	1.6	-1.7	0.0	0.0	5.6	0.0	7.2	6.6

Point Source, ISO 9613, Name: "Battery Energy Storage System 120", ID: "I0005!BESS120"																				
Nr.	X	Y	Z	Refl.	DEN	Freq.	Lw	l/a	Optime	K0	Di	Adiv	Aatm	Agr	Afol	Ahous	Abar	Cmet	RL	Lr
	(m)	(m)	(m)			(Hz)	dB(A)	dB	dB	(dB)	(dB)	(dB)	(dB)	(dB)	(dB)	(dB)	(dB)	(dB)	(dB)	dB(A)
0261	340599.24	5028562.90	103.95	0	DEN	A	84.4	0.0	0.0	0.0	0.0	65.0	2.2	-1.8	0.0	0.0	5.1	0.0	0.0	13.9

Point Source, ISO 9613, Name: "Battery Energy Storage System 195", ID: "I0009!BESS195"																				
Nr.	X	Y	Z	Refl.	DEN	Freq.	Lw	l/a	Optime	K0	Di	Adiv	Aatm	Agr	Afol	Ahous	Abar	Cmet	RL	Lr
	(m)	(m)	(m)			(Hz)	dB(A)	dB	dB	(dB)	(dB)	(dB)	(dB)	(dB)	(dB)	(dB)	(dB)	(dB)	(dB)	dB(A)
0288	340409.73	5028586.68	103.95	0	DEN	A	84.4	0.0	0.0	0.0	0.0	65.0	2.2	-1.5	0.0	0.0	4.8	0.0	0.0	13.8
0290	340409.73	5028586.68	103.95	1	DEN	A	84.4	0.0	0.0	0.0	0.0	65.5	2.3	-1.7	0.0	0.0	4.8	0.0	2.6	11.0

Point Source, ISO 9613, Name: "Battery Energy Storage System 202", ID: "I0009!BESS202"																				
Nr.	X	Y	Z	Refl.	DEN	Freq.	Lw	l/a	Optime	K0	Di	Adiv	Aatm	Agr	Afol	Ahous	Abar	Cmet	RL	Lr
	(m)	(m)	(m)			(Hz)	dB(A)	dB	dB	(dB)	(dB)	(dB)	(dB)	(dB)	(dB)	(dB)	(dB)	(dB)	(dB)	dB(A)
0313	340425.19	5028581.29	103.95	0	DEN	A	84.4	0.0	0.0	0.0	0.0	65.1	2.2	-1.4	0.0	0.0	5.3	0.0	0.0	13.3
0314	340425.19	5028581.29	103.95	1	DEN	A	84.4	0.0	0.0	0.0	0.0	65.6	2.3	-1.8	0.0	0.0	4.8	0.0	3.8	9.8

Point Source, ISO 9613, Name: "Medium Voltage Substation 034", ID: "I02!MVT034"																				
Nr.	X	Y	Z	Refl.	DEN	Freq.	Lw	l/a	Optime	K0	Di	Adiv	Aatm	Agr	Afol	Ahous	Abar	Cmet	RL	Lr
	(m)	(m)	(m)			(Hz)	dB(A)	dB	dB	(dB)	(dB)	(dB)	(dB)	(dB)	(dB)	(dB)	(dB)	(dB)	(dB)	dB(A)
0347	340624.79	5028560.01	103.20	0	DEN	A	84.5	0.0	0.0	0.0	0.0	65.1	1.6	-1.7	0.0	0.0	7.8	0.0	0.0	11.6

Point Source, ISO 9613, Name: "Battery Energy Storage System 199", ID: "I0009!BESS199"																				
Nr.	X	Y	Z	Refl.	DEN	Freq.	Lw	l/a	Optime	K0	Di	Adiv	Aatm	Agr	Afol	Ahous	Abar	Cmet	RL	Lr
	(m)	(m)	(m)			(Hz)	dB(A)	dB	dB	(dB)	(dB)	(dB)	(dB)	(dB)	(dB)	(dB)	(dB)	(dB)	(dB)	dB(A)
0385	340416.74	5028582.71	103.95	0	DEN	A	84.4	0.0	0.0	0.0	0.0	65.1	2.2	-1.5	0.0	0.0	5.1	0.0	0.0	13.5
0386	340416.74	5028582.71	103.95	1	DEN	A	84.4	0.0	0.0	0.0	0.0	65.5	2.3	-1.8	0.0	0.0	4.8	0.0	2.6	11.0

Point Source, ISO 9613, Name: "Battery Energy Storage System 133", ID: "I0004!BESS133"																				
Nr.	X	Y	Z	Refl.	DEN	Freq.	Lw	l/a	Optime	K0	Di	Adiv	Aatm	Agr	Afol	Ahous	Abar	Cmet	RL	Lr
	(m)	(m)	(m)			(Hz)	dB(A)	dB	dB	(dB)	(dB)	(dB)	(dB)	(dB)	(dB)	(dB)	(dB)	(dB)	(dB)	dB(A)
0422	340637.52	5028565.06	103.95	0	DEN	A	84.4	0.0	0.0	0.0	0.0	65.1	2.2	-1.9	0.0	0.0	13.3	0.0	0.0	5.7

Point Source, ISO 9613, Name: "Battery Energy Storage System 123", ID: "I0005!BESS123"																				
Nr.	X	Y	Z	Refl.	DEN	Freq.	Lw	l/a	Optime	K0	Di	Adiv	Aatm	Agr	Afol	Ahous	Abar	Cmet	RL	Lr
	(m)	(m)	(m)			(Hz)	dB(A)	dB	dB	(dB)	(dB)	(dB)	(dB)	(dB)	(dB)	(dB)	(dB)	(dB)	(dB)	dB(A)
0456	340607.70	5028561.49	103.95	0	DEN	A	84.4	0.0	0.0	0.0	0.0	65.1	2.2	-1.8	0.0	0.0	5.3	0.0	0.0	13.6

Sample Calculation at POR3 - Regular Operations

Point Source, ISO 9613, Name: "Medium Voltage Substation 058", ID: "I02!MVT058"																				
Nr.	X	Y	Z	Refl.	DEN	Freq.	Lw	l/a	Optime	K0	Di	Adiv	Aatm	Agr	Afol	Ahous	Abar	Cmet	RL	Lr
	(m)	(m)	(m)			(Hz)	dB(A)	dB	dB	(dB)	(dB)	(dB)	(dB)	(dB)	(dB)	(dB)	(dB)	(dB)	(dB)	dB(A)
0486	340470.92	5028563.91	103.20	0	DEN	A	84.5	0.0	0.0	0.0	0.0	65.2	1.6	-1.8	0.0	0.0	8.0	0.0	0.0	11.5
0487	340470.92	5028563.91	103.20	1	DEN	A	84.5	0.0	0.0	0.0	0.0	65.9	1.7	-1.9	0.0	0.0	6.1	0.0	8.7	4.0
0516	340470.92	5028563.91	103.20	1	DEN	A	84.5	0.0	0.0	0.0	0.0	65.4	1.6	-1.8	0.0	0.0	5.5	0.0	7.1	6.6

Point Source, ISO 9613, Name: "Battery Energy Storage System 229", ID: "I0008!BESS229"																				
Nr.	X	Y	Z	Refl.	DEN	Freq.	Lw	l/a	Optime	K0	Di	Adiv	Aatm	Agr	Afol	Ahous	Abar	Cmet	RL	Lr
	(m)	(m)	(m)			(Hz)	dB(A)	dB	dB	(dB)	(dB)	(dB)	(dB)	(dB)	(dB)	(dB)	(dB)	(dB)	(dB)	dB(A)
0540	340481.60	5028566.41	103.95	0	DEN	A	84.4	0.0	0.0	0.0	0.0	65.1	2.2	-2.0	0.0	0.0	10.4	0.0	0.0	8.7
0541	340481.60	5028566.41	103.95	1	DEN	A	84.4	0.0	0.0	0.0	0.0	66.0	2.4	-2.2	0.0	0.0	4.8	0.0	12.8	0.6

Point Source, ISO 9613, Name: "Battery Energy Storage System 206", ID: "I0009!BESS206"																				
Nr.	X	Y	Z	Refl.	DEN	Freq.	Lw	l/a	Optime	K0	Di	Adiv	Aatm	Agr	Afol	Ahous	Abar	Cmet	RL	Lr
	(m)	(m)	(m)			(Hz)	dB(A)	dB	dB	(dB)	(dB)	(dB)	(dB)	(dB)	(dB)	(dB)	(dB)	(dB)	(dB)	dB(A)
0590	340432.20	5028577.32	103.95	0	DEN	A	84.4	0.0	0.0	0.0	0.0	65.1	2.2	-1.5	0.0	0.0	5.3	0.0	0.0	13.3
0591	340432.20	5028577.32	103.95	1	DEN	A	84.4	0.0	0.0	0.0	0.0	65.6	2.3	-1.8	0.0	0.0	4.8	0.0	3.8	9.7

Point Source, ISO 9613, Name: "Battery Energy Storage System 232", ID: "I0008!BESS232"																				
Nr.	X	Y	Z	Refl.	DEN	Freq.	Lw	l/a	Optime	K0	Di	Adiv	Aatm	Agr	Afol	Ahous	Abar	Cmet	RL	Lr
	(m)	(m)	(m)			(Hz)	dB(A)	dB	dB	(dB)	(dB)	(dB)	(dB)	(dB)	(dB)	(dB)	(dB)	(dB)	(dB)	dB(A)
0628	340490.06	5028565.00	103.95	0	DEN	A	84.4	0.0	0.0	0.0	0.0	65.1	2.2	-2.0	0.0	0.0	13.6	0.0	0.0	5.5
0629	340490.06	5028565.00	103.95	1	DEN	A	84.4	0.0	0.0	0.0	0.0	66.1	2.4	-2.3	0.0	0.0	4.8	0.0	12.8	0.5

Point Source, ISO 9613, Name: "Battery Energy Storage System 203", ID: "I0009!BESS203"																				
Nr.	X	Y	Z	Refl.	DEN	Freq.	Lw	l/a	Optime	K0	Di	Adiv	Aatm	Agr	Afol	Ahous	Abar	Cmet	RL	Lr
	(m)	(m)	(m)			(Hz)	dB(A)	dB	dB	(dB)	(dB)	(dB)	(dB)	(dB)	(dB)	(dB)	(dB)	(dB)	(dB)	dB(A)
0674	340423.75	5028578.73	103.95	0	DEN	A	84.4	0.0	0.0	0.0	0.0	65.1	2.2	-1.5	0.0	0.0	5.1	0.0	0.0	13.5
0675	340423.75	5028578.73	103.95	1	DEN	A	84.4	0.0	0.0	0.0	0.0	65.5	2.3	-1.8	0.0	0.0	4.8	0.0	2.6	11.0

Point Source, ISO 9613, Name: "Battery Energy Storage System 134", ID: "I0004!BESS134"																				
Nr.	X	Y	Z	Refl.	DEN	Freq.	Lw	l/a	Optime	K0	Di	Adiv	Aatm	Agr	Afol	Ahous	Abar	Cmet	RL	Lr
	(m)	(m)	(m)			(Hz)	dB(A)	dB	dB	(dB)	(dB)	(dB)	(dB)	(dB)	(dB)	(dB)	(dB)	(dB)	(dB)	dB(A)
0700	340636.07	5028562.50	103.95	0	DEN	A	84.4	0.0	0.0	0.0	0.0	65.1	2.2	-1.9	0.0	0.0	10.2	0.0	0.0	8.8

Point Source, ISO 9613, Name: "Battery Energy Storage System 124", ID: "I0005!BESS124"																				
Nr.	X	Y	Z	Refl.	DEN	Freq.	Lw	l/a	Optime	K0	Di	Adiv	Aatm	Agr	Afol	Ahous	Abar	Cmet	RL	Lr
	(m)	(m)	(m)			(Hz)	dB(A)	dB	dB	(dB)	(dB)	(dB)	(dB)	(dB)	(dB)	(dB)	(dB)	(dB)	(dB)	dB(A)
0732	340606.25	5028558.93	103.95	0	DEN	A	84.4	0.0	0.0	0.0	0.0	65.1	2.2	-1.9	0.0	0.0	5.1	0.0	0.0	13.8

Point Source, ISO 9613, Name: "Battery Energy Storage System 210", ID: "I0009!BESS210"																				
Nr.	X	Y	Z	Refl.	DEN	Freq.	Lw	l/a	Optime	K0	Di	Adiv	Aatm	Agr	Afol	Ahous	Abar	Cmet	RL	Lr
	(m)	(m)	(m)			(Hz)	dB(A)	dB	dB	(dB)	(dB)	(dB)	(dB)	(dB)	(dB)	(dB)	(dB)	(dB)	(dB)	dB(A)
0770	340439.21	5028573.34	103.95	0	DEN	A	84.4	0.0	0.0	0.0	0.0	65.1	2.2	-1.6	0.0	0.0	5.3	0.0	0.0	13.3
0773	340439.21	5028573.34	103.95	1	DEN	A	84.4	0.0	0.0	0.0	0.0	65.6	2.3	-1.8	0.0	0.0	4.8	0.0	3.8	9.7

Point Source, ISO 9613, Name: "Medium Voltage Substation 059", ID: "I02!MVT059"																				
Nr.	X	Y	Z	Refl.	DEN	Freq.	Lw	l/a	Optime	K0	Di	Adiv	Aatm	Agr	Afol	Ahous	Abar	Cmet	RL	Lr
	(m)	(m)	(m)			(Hz)	dB(A)	dB	dB	(dB)	(dB)	(dB)	(dB)	(dB)	(dB)	(dB)	(dB)	(dB)	(dB)	dB(A)
0807	340477.93	5028559.94	103.20	0	DEN	A	84.5	0.0	0.0	0.0	0.0	65.2	1.6	-1.9	0.0	0.0	7.9	0.0	0.0	11.6
0810	340477.93	5028559.94	103.20	1	DEN	A	84.5	0.0	0.0	0.0	0.0	65.9	1.7	-1.9	0.0	0.0	6.1	0.0	8.7	4.0
0829	340477.93	5028559.94	103.20	1	DEN	A	84.5	0.0	0.0	0.0	0.0	65.4	1.6	-1.9	0.0	0.0	5.5	0.0	7.1	6.7

Point Source, ISO 9613, Name: "Battery Energy Storage System 233", ID: "I0008!BESS233"																				
Nr.	X	Y	Z	Refl.	DEN	Freq.	Lw	l/a	Optime	K0	Di	Adiv	Aatm	Agr	Afol	Ahous	Abar	Cmet	RL	Lr
	(m)	(m)	(m)			(Hz)	dB(A)	dB	dB	(dB)	(dB)	(dB)	(dB)	(dB)	(dB)	(dB)	(dB)	(dB)	(dB)	dB(A)
0859	340488.61	5028562.44	103.95	0	DEN	A	84.4	0.0	0.0	0.0	0.0	65.1	2.2	-2.0	0.0	0.0	10.3	0.0	0.0	8.7
0860	340488.61	5028562.44	103.95	1	DEN	A	84.4	0.0	0.0	0.0	0.0	66.1	2.4	-2.3	0.0	0.0	4.8	0.0	12.8	0.6

Point Source, ISO 9613, Name: "Battery Energy Storage System 207", ID: "I0009!BESS207"																				
Nr.	X	Y	Z	Refl.	DEN	Freq.	Lw	l/a	Optime	K0	Di	Adiv	Aatm	Agr	Afol	Ahous	Abar	Cmet	RL	Lr
	(m)	(m)	(m)			(Hz)	dB(A)	dB	dB	(dB)	(dB)	(dB)	(dB)	(dB)	(dB)	(dB)	(dB)	(dB)	(dB)	dB(A)
0904	340430.76	5028574.76	103.95	0	DEN	A	84.4	0.0	0.0	0.0	0.0	65.1	2.2	-1.5	0.0	0.0	5.1	0.0	0.0	13.5
0905	340430.76	5028574.76	103.95	1	DEN	A	84.4	0.0	0.0	0.0	0.0	65.5	2.3	-1.8	0.0	0.0	4.8	0.0	2.6	10.9

Sample Calculation at POR3 - Regular Operations

Point Source, ISO 9613, Name: "Medium Voltage Substation 035", ID: "I02!MVT035"																				
Nr.	X	Y	Z	Refl.	DEN	Freq.	Lw	l/a	Optime	K0	Di	Adiv	Aatm	Agr	Afol	Ahous	Abar	Cmet	RL	Lr
	(m)	(m)	(m)			(Hz)	dB(A)	dB	dB	(dB)	(dB)	(dB)	(dB)	(dB)	(dB)	(dB)	(dB)	(dB)	(dB)	dB(A)
0952	340631.77	5028556.05	103.20	0	DEN	A	84.5	0.0	0.0	0.0	0.0	65.2	1.6	-1.6	0.0	0.0	7.8	0.0	0.0	11.5

Point Source, ISO 9613, Name: "Battery Energy Storage System 236", ID: "I0008!BESS236"																				
Nr.	X	Y	Z	Refl.	DEN	Freq.	Lw	l/a	Optime	K0	Di	Adiv	Aatm	Agr	Afol	Ahous	Abar	Cmet	RL	Lr
	(m)	(m)	(m)			(Hz)	dB(A)	dB	dB	(dB)	(dB)	(dB)	(dB)	(dB)	(dB)	(dB)	(dB)	(dB)	(dB)	dB(A)
0983	340497.07	5028561.02	103.95	0	DEN	A	84.4	0.0	0.0	0.0	0.0	65.1	2.2	-1.9	0.0	0.0	13.5	0.0	0.0	5.4
0989	340497.07	5028561.02	103.95	1	DEN	A	84.4	0.0	0.0	0.0	0.0	66.1	2.4	-2.3	0.0	0.0	4.8	0.0	12.9	0.5

Point Source, ISO 9613, Name: "Battery Energy Storage System 127", ID: "I0005!BESS127"																				
Nr.	X	Y	Z	Refl.	DEN	Freq.	Lw	l/a	Optime	K0	Di	Adiv	Aatm	Agr	Afol	Ahous	Abar	Cmet	RL	Lr
	(m)	(m)	(m)			(Hz)	dB(A)	dB	dB	(dB)	(dB)	(dB)	(dB)	(dB)	(dB)	(dB)	(dB)	(dB)	(dB)	dB(A)
1030	340614.71	5028557.51	103.95	0	DEN	A	84.4	0.0	0.0	0.0	0.0	65.2	2.2	-1.8	0.0	0.0	5.3	0.0	0.0	13.5

Point Source, ISO 9613, Name: "Battery Energy Storage System 214", ID: "I0009!BESS214"																				
Nr.	X	Y	Z	Refl.	DEN	Freq.	Lw	l/a	Optime	K0	Di	Adiv	Aatm	Agr	Afol	Ahous	Abar	Cmet	RL	Lr
	(m)	(m)	(m)			(Hz)	dB(A)	dB	dB	(dB)	(dB)	(dB)	(dB)	(dB)	(dB)	(dB)	(dB)	(dB)	(dB)	dB(A)
1062	340446.22	5028569.37	103.95	0	DEN	A	84.4	0.0	0.0	0.0	0.0	65.2	2.2	-1.7	0.0	0.0	5.3	0.0	0.0	13.4
1064	340446.22	5028569.37	103.95	1	DEN	A	84.4	0.0	0.0	0.0	0.0	65.7	2.3	-1.9	0.0	0.0	4.8	0.0	3.8	9.8

Point Source, ISO 9613, Name: "Battery Energy Storage System 137", ID: "I0004!BESS137"																				
Nr.	X	Y	Z	Refl.	DEN	Freq.	Lw	l/a	Optime	K0	Di	Adiv	Aatm	Agr	Afol	Ahous	Abar	Cmet	RL	Lr
	(m)	(m)	(m)			(Hz)	dB(A)	dB	dB	(dB)	(dB)	(dB)	(dB)	(dB)	(dB)	(dB)	(dB)	(dB)	(dB)	dB(A)
1103	340644.53	5028561.08	103.95	0	DEN	A	84.4	0.0	0.0	0.0	0.0	65.2	2.2	-1.9	0.0	0.0	13.3	0.0	0.0	5.6

Point Source, ISO 9613, Name: "Battery Energy Storage System 211", ID: "I0009!BESS211"																				
Nr.	X	Y	Z	Refl.	DEN	Freq.	Lw	l/a	Optime	K0	Di	Adiv	Aatm	Agr	Afol	Ahous	Abar	Cmet	RL	Lr
	(m)	(m)	(m)			(Hz)	dB(A)	dB	dB	(dB)	(dB)	(dB)	(dB)	(dB)	(dB)	(dB)	(dB)	(dB)	(dB)	dB(A)
1139	340437.76	5028570.79	103.95	0	DEN	A	84.4	0.0	0.0	0.0	0.0	65.2	2.2	-1.6	0.0	0.0	5.1	0.0	0.0	13.5
1140	340437.76	5028570.79	103.95	1	DEN	A	84.4	0.0	0.0	0.0	0.0	65.6	2.3	-1.7	0.0	0.0	4.8	0.0	2.6	10.9

Point Source, ISO 9613, Name: "Medium Voltage Substation 060", ID: "I02!MVT060"																				
Nr.	X	Y	Z	Refl.	DEN	Freq.	Lw	l/a	Optime	K0	Di	Adiv	Aatm	Agr	Afol	Ahous	Abar	Cmet	RL	Lr
	(m)	(m)	(m)			(Hz)	dB(A)	dB	dB	(dB)	(dB)	(dB)	(dB)	(dB)	(dB)	(dB)	(dB)	(dB)	(dB)	dB(A)
1177	340484.94	5028555.97	103.20	0	DEN	A	84.5	0.0	0.0	0.0	0.0	65.3	1.6	-1.8	0.0	0.0	7.9	0.0	0.0	11.6
1179	340484.94	5028555.97	103.20	1	DEN	A	84.5	0.0	0.0	0.0	0.0	66.0	1.7	-1.9	0.0	0.0	6.0	0.0	8.7	4.1
1196	340484.94	5028555.97	103.20	1	DEN	A	84.5	0.0	0.0	0.0	0.0	65.5	1.6	-2.0	0.0	0.0	5.5	0.0	7.1	6.8

Point Source, ISO 9613, Name: "Battery Energy Storage System 237", ID: "I0008!BESS237"																				
Nr.	X	Y	Z	Refl.	DEN	Freq.	Lw	l/a	Optime	K0	Di	Adiv	Aatm	Agr	Afol	Ahous	Abar	Cmet	RL	Lr
	(m)	(m)	(m)			(Hz)	dB(A)	dB	dB	(dB)	(dB)	(dB)	(dB)	(dB)	(dB)	(dB)	(dB)	(dB)	(dB)	dB(A)
1226	340495.62	5028558.46	103.95	0	DEN	A	84.4	0.0	0.0	0.0	0.0	65.2	2.2	-2.0	0.0	0.0	10.3	0.0	0.0	8.6
1231	340495.62	5028558.46	103.95	1	DEN	A	84.4	0.0	0.0	0.0	0.0	66.1	2.4	-2.3	0.0	0.0	4.8	0.0	12.8	0.6

Point Source, ISO 9613, Name: "Battery Energy Storage System 240", ID: "I0008!BESS240"																				
Nr.	X	Y	Z	Refl.	DEN	Freq.	Lw	l/a	Optime	K0	Di	Adiv	Aatm	Agr	Afol	Ahous	Abar	Cmet	RL	Lr
	(m)	(m)	(m)			(Hz)	dB(A)	dB	dB	(dB)	(dB)	(dB)	(dB)	(dB)	(dB)	(dB)	(dB)	(dB)	(dB)	dB(A)
1268	340504.08	5028557.05	103.95	0	DEN	A	84.4	0.0	0.0	0.0	0.0	65.2	2.2	-1.8	0.0	0.0	13.1	0.0	0.0	5.6
1274	340504.08	5028557.05	103.95	1	DEN	A	84.4	0.0	0.0	0.0	0.0	66.2	2.5	-2.4	0.0	0.0	4.8	0.0	12.9	0.5

Point Source, ISO 9613, Name: "Battery Energy Storage System 218", ID: "I0009!BESS218"																				
Nr.	X	Y	Z	Refl.	DEN	Freq.	Lw	l/a	Optime	K0	Di	Adiv	Aatm	Agr	Afol	Ahous	Abar	Cmet	RL	Lr
	(m)	(m)	(m)			(Hz)	dB(A)	dB	dB	(dB)	(dB)	(dB)	(dB)	(dB)	(dB)	(dB)	(dB)	(dB)	(dB)	dB(A)
1315	340453.23	5028565.39	103.95	0	DEN	A	84.4	0.0	0.0	0.0	0.0	65.2	2.2	-1.8	0.0	0.0	5.2	0.0	0.0	13.5
1317	340453.23	5028565.39	103.95	1	DEN	A	84.4	0.0	0.0	0.0	0.0	65.7	2.3	-2.0	0.0	0.0	4.8	0.0	3.8	9.8

Point Source, ISO 9613, Name: "Battery Energy Storage System 128", ID: "I0005!BESS128"																				
Nr.	X	Y	Z	Refl.	DEN	Freq.	Lw	l/a	Optime	K0	Di	Adiv	Aatm	Agr	Afol	Ahous	Abar	Cmet	RL	Lr
	(m)	(m)	(m)			(Hz)	dB(A)	dB	dB	(dB)	(dB)	(dB)	(dB)	(dB)	(dB)	(dB)	(dB)	(dB)	(dB)	dB(A)
1354	340613.26	5028554.96	103.95	0	DEN	A	84.4	0.0	0.0	0.0	0.0	65.2	2.2	-1.9	0.0	0.0	5.1	0.0	0.0	13.7

Point Source, ISO 9613, Name: "Battery Energy Storage System 138", ID: "I0004!BESS138"																				
Nr.	X	Y	Z	Refl.	DEN	Freq.	Lw	l/a	Optime	K0	Di	Adiv	Aatm	Agr	Afol	Ahous	Abar	Cmet	RL	Lr
	(m)	(m)	(m)			(Hz)	dB(A)	dB	dB	(dB)	(dB)	(dB)	(dB)	(dB)	(dB)	(dB)	(dB)	(dB)	(dB)	dB(A)
1384	340643.08	5028558.53	103.95	0	DEN	A	84.4	0.0	0.0	0.0	0.0	65.2	2.2	-1.9	0.0	0.0	10.1	0.0	0.0	8.7

Sample Calculation at POR3 - Regular Operations

Point Source, ISO 9613, Name: "Battery Energy Storage System 215", ID: "I0009!BESS215"																				
Nr.	X	Y	Z	Refl.	DEN	Freq.	Lw	l/a	Optime	K0	Di	Adiv	Aatm	Agr	Afol	Ahous	Abar	Cmet	RL	Lr
	(m)	(m)	(m)			(Hz)	dB(A)	dB	dB	(dB)	(dB)	(dB)	(dB)	(dB)	(dB)	(dB)	(dB)	(dB)	(dB)	dB(A)
1414	340444.77	5028566.81	103.95	0	DEN	A	84.4	0.0	0.0	0.0	0.0	65.2	2.2	-1.7	0.0	0.0	5.1	0.0	0.0	13.6
1415	340444.77	5028566.81	103.95	1	DEN	A	84.4	0.0	0.0	0.0	0.0	65.6	2.3	-1.9	0.0	0.0	4.8	0.0	2.6	11.0

Point Source, ISO 9613, Name: "Medium Voltage Substation 036", ID: "I02!MVT036"																				
Nr.	X	Y	Z	Refl.	DEN	Freq.	Lw	l/a	Optime	K0	Di	Adiv	Aatm	Agr	Afol	Ahous	Abar	Cmet	RL	Lr
	(m)	(m)	(m)			(Hz)	dB(A)	dB	dB	(dB)	(dB)	(dB)	(dB)	(dB)	(dB)	(dB)	(dB)	(dB)	(dB)	dB(A)
1454	340639.41	5028552.06	103.20	0	DEN	A	84.5	0.0	0.0	0.0	0.0	65.3	1.6	-1.7	0.0	0.0	7.8	0.0	0.0	11.5

Point Source, ISO 9613, Name: "Medium Voltage Substation 061", ID: "I02!MVT061"																				
Nr.	X	Y	Z	Refl.	DEN	Freq.	Lw	l/a	Optime	K0	Di	Adiv	Aatm	Agr	Afol	Ahous	Abar	Cmet	RL	Lr
	(m)	(m)	(m)			(Hz)	dB(A)	dB	dB	(dB)	(dB)	(dB)	(dB)	(dB)	(dB)	(dB)	(dB)	(dB)	(dB)	dB(A)
1490	340491.95	5028551.99	103.20	0	DEN	A	84.5	0.0	0.0	0.0	0.0	65.3	1.6	-1.9	0.0	0.0	7.8	0.0	0.0	11.6
1491	340491.95	5028551.99	103.20	1	DEN	A	84.5	0.0	0.0	0.0	0.0	66.0	1.7	-2.0	0.0	0.0	6.0	0.0	8.7	4.1
1530	340491.95	5028551.99	103.20	1	DEN	A	84.5	0.0	0.0	0.0	0.0	65.5	1.6	-2.1	0.0	0.0	5.5	0.0	7.2	6.8

Point Source, ISO 9613, Name: "Battery Energy Storage System 241", ID: "I0008!BESS241"																				
Nr.	X	Y	Z	Refl.	DEN	Freq.	Lw	l/a	Optime	K0	Di	Adiv	Aatm	Agr	Afol	Ahous	Abar	Cmet	RL	Lr
	(m)	(m)	(m)			(Hz)	dB(A)	dB	dB	(dB)	(dB)	(dB)	(dB)	(dB)	(dB)	(dB)	(dB)	(dB)	(dB)	dB(A)
1559	340502.63	5028554.49	103.95	0	DEN	A	84.4	0.0	0.0	0.0	0.0	65.2	2.3	-1.8	0.0	0.0	10.0	0.0	0.0	8.7
1565	340502.63	5028554.49	103.95	1	DEN	A	84.4	0.0	0.0	0.0	0.0	66.1	2.4	-2.4	0.0	0.0	4.8	0.0	12.9	0.6

Point Source, ISO 9613, Name: "Battery Energy Storage System 131", ID: "I0005!BESS131"																				
Nr.	X	Y	Z	Refl.	DEN	Freq.	Lw	l/a	Optime	K0	Di	Adiv	Aatm	Agr	Afol	Ahous	Abar	Cmet	RL	Lr
	(m)	(m)	(m)			(Hz)	dB(A)	dB	dB	(dB)	(dB)	(dB)	(dB)	(dB)	(dB)	(dB)	(dB)	(dB)	(dB)	dB(A)
1592	340621.72	5028553.54	103.95	0	DEN	A	84.4	0.0	0.0	0.0	0.0	65.2	2.3	-1.9	0.0	0.0	5.3	0.0	0.0	13.5

Point Source, ISO 9613, Name: "Battery Energy Storage System 222", ID: "I0009!BESS222"																				
Nr.	X	Y	Z	Refl.	DEN	Freq.	Lw	l/a	Optime	K0	Di	Adiv	Aatm	Agr	Afol	Ahous	Abar	Cmet	RL	Lr
	(m)	(m)	(m)			(Hz)	dB(A)	dB	dB	(dB)	(dB)	(dB)	(dB)	(dB)	(dB)	(dB)	(dB)	(dB)	(dB)	dB(A)
1622	340460.24	5028561.42	103.95	0	DEN	A	84.4	0.0	0.0	0.0	0.0	65.2	2.3	-1.9	0.0	0.0	5.2	0.0	0.0	13.5
1623	340460.24	5028561.42	103.95	1	DEN	A	84.4	0.0	0.0	0.0	0.0	65.7	2.4	-2.1	0.0	0.0	4.8	0.0	3.8	9.9

Point Source, ISO 9613, Name: "Battery Energy Storage System 219", ID: "I0009!BESS219"																				
Nr.	X	Y	Z	Refl.	DEN	Freq.	Lw	l/a	Optime	K0	Di	Adiv	Aatm	Agr	Afol	Ahous	Abar	Cmet	RL	Lr
	(m)	(m)	(m)			(Hz)	dB(A)	dB	dB	(dB)	(dB)	(dB)	(dB)	(dB)	(dB)	(dB)	(dB)	(dB)	(dB)	dB(A)
1661	340451.78	5028562.84	103.95	0	DEN	A	84.4	0.0	0.0	0.0	0.0	65.2	2.3	-1.8	0.0	0.0	5.1	0.0	0.0	13.6
1662	340451.78	5028562.84	103.95	1	DEN	A	84.4	0.0	0.0	0.0	0.0	65.6	2.3	-2.0	0.0	0.0	4.8	0.0	2.6	11.0

Point Source, ISO 9613, Name: "Medium Voltage Substation 062", ID: "I02!MVT062"																				
Nr.	X	Y	Z	Refl.	DEN	Freq.	Lw	l/a	Optime	K0	Di	Adiv	Aatm	Agr	Afol	Ahous	Abar	Cmet	RL	Lr
	(m)	(m)	(m)			(Hz)	dB(A)	dB	dB	(dB)	(dB)	(dB)	(dB)	(dB)	(dB)	(dB)	(dB)	(dB)	(dB)	dB(A)
1697	340498.96	5028548.02	103.20	0	DEN	A	84.5	0.0	0.0	0.0	0.0	65.4	1.6	-1.7	0.0	0.0	7.7	0.0	0.0	11.6
1698	340498.96	5028548.02	103.20	1	DEN	A	84.5	0.0	0.0	0.0	0.0	66.0	1.7	-2.0	0.0	0.0	6.0	0.0	8.6	4.1
1724	340498.96	5028548.02	103.20	1	DEN	A	84.5	0.0	0.0	0.0	0.0	65.5	1.6	-2.0	0.0	0.0	5.5	0.0	7.1	6.7

Point Source, ISO 9613, Name: "Battery Energy Storage System 132", ID: "I0005!BESS132"																				
Nr.	X	Y	Z	Refl.	DEN	Freq.	Lw	l/a	Optime	K0	Di	Adiv	Aatm	Agr	Afol	Ahous	Abar	Cmet	RL	Lr
	(m)	(m)	(m)			(Hz)	dB(A)	dB	dB	(dB)	(dB)	(dB)	(dB)	(dB)	(dB)	(dB)	(dB)	(dB)	(dB)	dB(A)
1743	340620.27	5028550.98	103.95	0	DEN	A	84.4	0.0	0.0	0.0	0.0	65.3	2.3	-1.9	0.0	0.0	5.1	0.0	0.0	13.7

Point Source, ISO 9613, Name: "Battery Energy Storage System 244", ID: "I000A!BESS244"																				
Nr.	X	Y	Z	Refl.	DEN	Freq.	Lw	l/a	Optime	K0	Di	Adiv	Aatm	Agr	Afol	Ahous	Abar	Cmet	RL	Lr
	(m)	(m)	(m)			(Hz)	dB(A)	dB	dB	(dB)	(dB)	(dB)	(dB)	(dB)	(dB)	(dB)	(dB)	(dB)	(dB)	dB(A)
1769	340395.00	5028577.06	103.95	0	DEN	A	84.4	0.0	0.0	0.0	0.0	65.3	2.3	-1.6	0.0	0.0	9.6	0.0	0.0	8.9

Point Source, ISO 9613, Name: "Battery Energy Storage System 226", ID: "I0009!BESS226"																				
Nr.	X	Y	Z	Refl.	DEN	Freq.	Lw	l/a	Optime	K0	Di	Adiv	Aatm	Agr	Afol	Ahous	Abar	Cmet	RL	Lr
	(m)	(m)	(m)			(Hz)	dB(A)	dB	dB	(dB)	(dB)	(dB)	(dB)	(dB)	(dB)	(dB)	(dB)	(dB)	(dB)	dB(A)
1795	340467.25	5028557.44	103.95	0	DEN	A	84.4	0.0	0.0	0.0	0.0	65.3	2.3	-1.9	0.0	0.0	5.2	0.0	0.0	13.6
1796	340467.25	5028557.44	103.95	1	DEN	A	84.4	0.0	0.0	0.0	0.0	65.8	2.4	-2.1	0.0	0.0	4.8	0.0	3.8	9.9

Sample Calculation at POR3 - Regular Operations

Point Source, ISO 9613, Name: "Battery Energy Storage System 223", ID: "!0009!BESS223"																				
Nr.	X	Y	Z	Refl.	DEN	Freq.	Lw	l/a	Optime	K0	Di	Adiv	Aatm	Agr	Afol	Ahous	Abar	Cmet	RL	Lr
	(m)	(m)	(m)			(Hz)	dB(A)	dB	dB	(dB)	(dB)	(dB)	(dB)	(dB)	(dB)	(dB)	(dB)	(dB)	(dB)	dB(A)
1831	340458.79	5028558.86	103.95	0	DEN	A	84.4	0.0	0.0	0.0	0.0	65.3	2.3	-1.9	0.0	0.0	5.0	0.0	0.0	13.7
1832	340458.79	5028558.86	103.95	1	DEN	A	84.4	0.0	0.0	0.0	0.0	65.7	2.3	-2.0	0.0	0.0	4.8	0.0	2.6	11.0

Point Source, ISO 9613, Name: "Battery Energy Storage System 248", ID: "!000A!BESS248"																				
Nr.	X	Y	Z	Refl.	DEN	Freq.	Lw	l/a	Optime	K0	Di	Adiv	Aatm	Agr	Afol	Ahous	Abar	Cmet	RL	Lr
	(m)	(m)	(m)			(Hz)	dB(A)	dB	dB	(dB)	(dB)	(dB)	(dB)	(dB)	(dB)	(dB)	(dB)	(dB)	(dB)	dB(A)
1866	340402.01	5028573.08	103.95	0	DEN	A	84.4	0.0	0.0	0.0	0.0	65.3	2.3	-1.7	0.0	0.0	13.1	0.0	0.0	5.4

Point Source, ISO 9613, Name: "Battery Energy Storage System 135", ID: "!0005!BESS135"																				
Nr.	X	Y	Z	Refl.	DEN	Freq.	Lw	l/a	Optime	K0	Di	Adiv	Aatm	Agr	Afol	Ahous	Abar	Cmet	RL	Lr
	(m)	(m)	(m)			(Hz)	dB(A)	dB	dB	(dB)	(dB)	(dB)	(dB)	(dB)	(dB)	(dB)	(dB)	(dB)	(dB)	dB(A)
1894	340628.73	5028549.56	103.95	0	DEN	A	84.4	0.0	0.0	0.0	0.0	65.3	2.3	-1.9	0.0	0.0	5.3	0.0	0.0	13.4

Point Source, ISO 9613, Name: "Battery Energy Storage System 230", ID: "!0009!BESS230"																				
Nr.	X	Y	Z	Refl.	DEN	Freq.	Lw	l/a	Optime	K0	Di	Adiv	Aatm	Agr	Afol	Ahous	Abar	Cmet	RL	Lr
	(m)	(m)	(m)			(Hz)	dB(A)	dB	dB	(dB)	(dB)	(dB)	(dB)	(dB)	(dB)	(dB)	(dB)	(dB)	(dB)	dB(A)
1924	340474.26	5028553.47	103.95	0	DEN	A	84.4	0.0	0.0	0.0	0.0	65.3	2.3	-2.0	0.0	0.0	5.2	0.0	0.0	13.6
1926	340474.26	5028553.47	103.95	1	DEN	A	84.4	0.0	0.0	0.0	0.0	65.8	2.4	-2.2	0.0	0.0	4.8	0.0	3.8	9.9

Point Source, ISO 9613, Name: "Battery Energy Storage System 227", ID: "!0009!BESS227"																				
Nr.	X	Y	Z	Refl.	DEN	Freq.	Lw	l/a	Optime	K0	Di	Adiv	Aatm	Agr	Afol	Ahous	Abar	Cmet	RL	Lr
	(m)	(m)	(m)			(Hz)	dB(A)	dB	dB	(dB)	(dB)	(dB)	(dB)	(dB)	(dB)	(dB)	(dB)	(dB)	(dB)	dB(A)
1970	340465.80	5028554.89	103.95	0	DEN	A	84.4	0.0	0.0	0.0	0.0	65.3	2.3	-2.0	0.0	0.0	5.0	0.0	0.0	13.7
1971	340465.80	5028554.89	103.95	1	DEN	A	84.4	0.0	0.0	0.0	0.0	65.7	2.4	-2.1	0.0	0.0	4.8	0.0	2.6	11.1

Point Source, ISO 9613, Name: "Battery Energy Storage System 245", ID: "!000A!BESS245"																				
Nr.	X	Y	Z	Refl.	DEN	Freq.	Lw	l/a	Optime	K0	Di	Adiv	Aatm	Agr	Afol	Ahous	Abar	Cmet	RL	Lr
	(m)	(m)	(m)			(Hz)	dB(A)	dB	dB	(dB)	(dB)	(dB)	(dB)	(dB)	(dB)	(dB)	(dB)	(dB)	(dB)	dB(A)
2008	340393.55	5028574.50	103.95	0	DEN	A	84.4	0.0	0.0	0.0	0.0	65.3	2.3	-1.7	0.0	0.0	7.1	0.0	0.0	11.4

Point Source, ISO 9613, Name: "Battery Energy Storage System 252", ID: "!000A!BESS252"																				
Nr.	X	Y	Z	Refl.	DEN	Freq.	Lw	l/a	Optime	K0	Di	Adiv	Aatm	Agr	Afol	Ahous	Abar	Cmet	RL	Lr
	(m)	(m)	(m)			(Hz)	dB(A)	dB	dB	(dB)	(dB)	(dB)	(dB)	(dB)	(dB)	(dB)	(dB)	(dB)	(dB)	dB(A)
2029	340409.02	5028569.11	103.95	0	DEN	A	84.4	0.0	0.0	0.0	0.0	65.3	2.3	-1.7	0.0	0.0	13.7	0.0	0.0	4.8

Point Source, ISO 9613, Name: "Battery Energy Storage System 249", ID: "!000A!BESS249"																				
Nr.	X	Y	Z	Refl.	DEN	Freq.	Lw	l/a	Optime	K0	Di	Adiv	Aatm	Agr	Afol	Ahous	Abar	Cmet	RL	Lr
	(m)	(m)	(m)			(Hz)	dB(A)	dB	dB	(dB)	(dB)	(dB)	(dB)	(dB)	(dB)	(dB)	(dB)	(dB)	(dB)	dB(A)
2062	340400.56	5028570.52	103.95	0	DEN	A	84.4	0.0	0.0	0.0	0.0	65.4	2.3	-1.7	0.0	0.0	10.1	0.0	0.0	8.3

Point Source, ISO 9613, Name: "Battery Energy Storage System 136", ID: "!0005!BESS136"																				
Nr.	X	Y	Z	Refl.	DEN	Freq.	Lw	l/a	Optime	K0	Di	Adiv	Aatm	Agr	Afol	Ahous	Abar	Cmet	RL	Lr
	(m)	(m)	(m)			(Hz)	dB(A)	dB	dB	(dB)	(dB)	(dB)	(dB)	(dB)	(dB)	(dB)	(dB)	(dB)	(dB)	dB(A)
2084	340627.28	5028547.01	103.95	0	DEN	A	84.4	0.0	0.0	0.0	0.0	65.4	2.3	-1.9	0.0	0.0	5.1	0.0	0.0	13.6

Point Source, ISO 9613, Name: "Battery Energy Storage System 256", ID: "!000A!BESS256"																				
Nr.	X	Y	Z	Refl.	DEN	Freq.	Lw	l/a	Optime	K0	Di	Adiv	Aatm	Agr	Afol	Ahous	Abar	Cmet	RL	Lr
	(m)	(m)	(m)			(Hz)	dB(A)	dB	dB	(dB)	(dB)	(dB)	(dB)	(dB)	(dB)	(dB)	(dB)	(dB)	(dB)	dB(A)
2115	340416.03	5028565.14	103.95	0	DEN	A	84.4	0.0	0.0	0.0	0.0	65.4	2.3	-1.7	0.0	0.0	13.7	0.0	0.0	4.8

Point Source, ISO 9613, Name: "Battery Energy Storage System 234", ID: "!0009!BESS234"																				
Nr.	X	Y	Z	Refl.	DEN	Freq.	Lw	l/a	Optime	K0	Di	Adiv	Aatm	Agr	Afol	Ahous	Abar	Cmet	RL	Lr
	(m)	(m)	(m)			(Hz)	dB(A)	dB	dB	(dB)	(dB)	(dB)	(dB)	(dB)	(dB)	(dB)	(dB)	(dB)	(dB)	dB(A)
2151	340481.27	5028549.49	103.95	0	DEN	A	84.4	0.0	0.0	0.0	0.0	65.4	2.3	-2.0	0.0	0.0	5.2	0.0	0.0	13.6
2152	340481.27	5028549.49	103.95	1	DEN	A	84.4	0.0	0.0	0.0	0.0	65.8	2.4	-2.3	0.0	0.0	4.8	0.0	3.8	9.9

Point Source, ISO 9613, Name: "Battery Energy Storage System 231", ID: "!0009!BESS231"																				
Nr.	X	Y	Z	Refl.	DEN	Freq.	Lw	l/a	Optime	K0	Di	Adiv	Aatm	Agr	Afol	Ahous	Abar	Cmet	RL	Lr
	(m)	(m)	(m)			(Hz)	dB(A)	dB	dB	(dB)	(dB)	(dB)	(dB)	(dB)	(dB)	(dB)	(dB)	(dB)	(dB)	dB(A)
2182	340472.81	5028550.91	103.95	0	DEN	A	84.4	0.0	0.0	0.0	0.0	65.4	2.3	-2.0	0.0	0.0	5.0	0.0	0.0	13.8
2183	340472.81	5028550.91	103.95	1	DEN	A	84.4	0.0	0.0	0.0	0.0	65.8	2.4	-2.2	0.0	0.0	4.8	0.0	2.6	11.1

Sample Calculation at POR3 - Regular Operations

Point Source, ISO 9613, Name: "Medium Voltage Substation 063", ID: "I02!MVT063"																				
Nr.	X	Y	Z	Refl.	DEN	Freq.	Lw	l/a	Optime	K0	Di	Adiv	Aatm	Agr	Afol	Ahous	Abar	Cmet	RL	Lr
	(m)	(m)	(m)			(Hz)	dB(A)	dB	dB	(dB)	(dB)	(dB)	(dB)	(dB)	(dB)	(dB)	(dB)	(dB)	(dB)	dB(A)
2221	340389.89	5028568.03	103.20	0	DEN	A	84.5	0.0	0.0	0.0	0.0	65.5	1.6	-1.4	0.0	0.0	5.2	0.0	0.0	13.6
2223	340389.89	5028568.03	103.20	1	DEN	A	84.5	0.0	0.0	0.0	0.0	65.7	1.7	-1.4	0.0	0.0	5.0	0.0	6.6	6.9

Point Source, ISO 9613, Name: "Battery Energy Storage System 253", ID: "I000A!BESS253"																				
Nr.	X	Y	Z	Refl.	DEN	Freq.	Lw	l/a	Optime	K0	Di	Adiv	Aatm	Agr	Afol	Ahous	Abar	Cmet	RL	Lr
	(m)	(m)	(m)			(Hz)	dB(A)	dB	dB	(dB)	(dB)	(dB)	(dB)	(dB)	(dB)	(dB)	(dB)	(dB)	(dB)	dB(A)
2232	340407.57	5028566.55	103.95	0	DEN	A	84.4	0.0	0.0	0.0	0.0	65.4	2.3	-1.7	0.0	0.0	10.5	0.0	0.0	7.9

Point Source, ISO 9613, Name: "Battery Energy Storage System 260", ID: "I000A!BESS260"																				
Nr.	X	Y	Z	Refl.	DEN	Freq.	Lw	l/a	Optime	K0	Di	Adiv	Aatm	Agr	Afol	Ahous	Abar	Cmet	RL	Lr
	(m)	(m)	(m)			(Hz)	dB(A)	dB	dB	(dB)	(dB)	(dB)	(dB)	(dB)	(dB)	(dB)	(dB)	(dB)	(dB)	dB(A)
2277	340423.04	5028561.16	103.95	0	DEN	A	84.4	0.0	0.0	0.0	0.0	65.4	2.3	-1.7	0.0	0.0	13.7	0.0	0.0	4.8

Point Source, ISO 9613, Name: "Battery Energy Storage System 139", ID: "I0005!BESS139"																				
Nr.	X	Y	Z	Refl.	DEN	Freq.	Lw	l/a	Optime	K0	Di	Adiv	Aatm	Agr	Afol	Ahous	Abar	Cmet	RL	Lr
	(m)	(m)	(m)			(Hz)	dB(A)	dB	dB	(dB)	(dB)	(dB)	(dB)	(dB)	(dB)	(dB)	(dB)	(dB)	(dB)	dB(A)
2311	340635.74	5028545.59	103.95	0	DEN	A	84.4	0.0	0.0	0.0	0.0	65.4	2.3	-2.0	0.0	0.0	5.3	0.0	0.0	13.4

Point Source, ISO 9613, Name: "Medium Voltage Substation 064", ID: "I02!MVT064"																				
Nr.	X	Y	Z	Refl.	DEN	Freq.	Lw	l/a	Optime	K0	Di	Adiv	Aatm	Agr	Afol	Ahous	Abar	Cmet	RL	Lr
	(m)	(m)	(m)			(Hz)	dB(A)	dB	dB	(dB)	(dB)	(dB)	(dB)	(dB)	(dB)	(dB)	(dB)	(dB)	(dB)	dB(A)
2341	340396.90	5028564.05	103.20	0	DEN	A	84.5	0.0	0.0	0.0	0.0	65.5	1.6	-1.4	0.0	0.0	7.8	0.0	0.0	11.0
2347	340396.90	5028564.05	103.20	1	DEN	A	84.5	0.0	0.0	0.0	0.0	65.7	1.7	-1.5	0.0	0.0	5.5	0.0	7.2	5.9

Point Source, ISO 9613, Name: "Battery Energy Storage System 257", ID: "I000A!BESS257"																				
Nr.	X	Y	Z	Refl.	DEN	Freq.	Lw	l/a	Optime	K0	Di	Adiv	Aatm	Agr	Afol	Ahous	Abar	Cmet	RL	Lr
	(m)	(m)	(m)			(Hz)	dB(A)	dB	dB	(dB)	(dB)	(dB)	(dB)	(dB)	(dB)	(dB)	(dB)	(dB)	(dB)	dB(A)
2366	340414.58	5028562.57	103.95	0	DEN	A	84.4	0.0	0.0	0.0	0.0	65.4	2.3	-1.8	0.0	0.0	10.5	0.0	0.0	8.0

Point Source, ISO 9613, Name: "Battery Energy Storage System 235", ID: "I0009!BESS235"																				
Nr.	X	Y	Z	Refl.	DEN	Freq.	Lw	l/a	Optime	K0	Di	Adiv	Aatm	Agr	Afol	Ahous	Abar	Cmet	RL	Lr
	(m)	(m)	(m)			(Hz)	dB(A)	dB	dB	(dB)	(dB)	(dB)	(dB)	(dB)	(dB)	(dB)	(dB)	(dB)	(dB)	dB(A)
2404	340479.82	5028546.94	103.95	0	DEN	A	84.4	0.0	0.0	0.0	0.0	65.4	2.3	-2.1	0.0	0.0	5.0	0.0	0.0	13.8
2405	340479.82	5028546.94	103.95	1	DEN	A	84.4	0.0	0.0	0.0	0.0	65.8	2.4	-2.3	0.0	0.0	4.8	0.0	2.6	11.1

Point Source, ISO 9613, Name: "Battery Energy Storage System 238", ID: "I0009!BESS238"																				
Nr.	X	Y	Z	Refl.	DEN	Freq.	Lw	l/a	Optime	K0	Di	Adiv	Aatm	Agr	Afol	Ahous	Abar	Cmet	RL	Lr
	(m)	(m)	(m)			(Hz)	dB(A)	dB	dB	(dB)	(dB)	(dB)	(dB)	(dB)	(dB)	(dB)	(dB)	(dB)	(dB)	dB(A)
2438	340488.28	5028545.52	103.95	0	DEN	A	84.4	0.0	0.0	0.0	0.0	65.4	2.3	-2.1	0.0	0.0	5.2	0.0	0.0	13.6
2439	340488.28	5028545.52	103.95	1	DEN	A	84.4	0.0	0.0	0.0	0.0	65.9	2.4	-2.3	0.0	0.0	4.8	0.0	3.8	9.9

Point Source, ISO 9613, Name: "Medium Voltage Substation 065", ID: "I02!MVT065"																				
Nr.	X	Y	Z	Refl.	DEN	Freq.	Lw	l/a	Optime	K0	Di	Adiv	Aatm	Agr	Afol	Ahous	Abar	Cmet	RL	Lr
	(m)	(m)	(m)			(Hz)	dB(A)	dB	dB	(dB)	(dB)	(dB)	(dB)	(dB)	(dB)	(dB)	(dB)	(dB)	(dB)	dB(A)
2471	340403.91	5028560.08	103.20	0	DEN	A	84.5	0.0	0.0	0.0	0.0	65.5	1.6	-1.5	0.0	0.0	8.0	0.0	0.0	10.8
2490	340403.91	5028560.08	103.20	1	DEN	A	84.5	0.0	0.0	0.0	0.0	65.7	1.7	-1.5	0.0	0.0	5.6	0.0	7.3	5.7

Point Source, ISO 9613, Name: "Battery Energy Storage System 264", ID: "I000A!BESS264"																				
Nr.	X	Y	Z	Refl.	DEN	Freq.	Lw	l/a	Optime	K0	Di	Adiv	Aatm	Agr	Afol	Ahous	Abar	Cmet	RL	Lr
	(m)	(m)	(m)			(Hz)	dB(A)	dB	dB	(dB)	(dB)	(dB)	(dB)	(dB)	(dB)	(dB)	(dB)	(dB)	(dB)	dB(A)
2511	340430.05	5028557.19	103.95	0	DEN	A	84.4	0.0	0.0	0.0	0.0	65.4	2.3	-1.7	0.0	0.0	13.7	0.0	0.0	4.8

Point Source, ISO 9613, Name: "Battery Energy Storage System 140", ID: "I0005!BESS140"																				
Nr.	X	Y	Z	Refl.	DEN	Freq.	Lw	l/a	Optime	K0	Di	Adiv	Aatm	Agr	Afol	Ahous	Abar	Cmet	RL	Lr
	(m)	(m)	(m)			(Hz)	dB(A)	dB	dB	(dB)	(dB)	(dB)	(dB)	(dB)	(dB)	(dB)	(dB)	(dB)	(dB)	dB(A)
2542	340634.29	5028543.03	103.95	0	DEN	A	84.4	0.0	0.0	0.0	0.0	65.4	2.3	-1.9	0.0	0.0	5.1	0.0	0.0	13.5

Point Source, ISO 9613, Name: "Battery Energy Storage System 261", ID: "I000A!BESS261"																				
Nr.	X	Y	Z	Refl.	DEN	Freq.	Lw	l/a	Optime	K0	Di	Adiv	Aatm	Agr	Afol	Ahous	Abar	Cmet	RL	Lr
	(m)	(m)	(m)			(Hz)	dB(A)	dB	dB	(dB)	(dB)	(dB)	(dB)	(dB)	(dB)	(dB)	(dB)	(dB)	(dB)	dB(A)
2561	340421.59	5028558.60	103.95	0	DEN	A	84.4	0.0	0.0	0.0	0.0	65.4	2.3	-1.8	0.0	0.0	10.5	0.0	0.0	7.9

Sample Calculation at POR3 - Regular Operations

Point Source, ISO 9613, Name: "Medium Voltage Substation 066", ID: "I02!MVT066"																				
Nr.	X	Y	Z	Refl.	DEN	Freq.	Lw	l/a	Optime	K0	Di	Adiv	Aatm	Agr	Afol	Ahous	Abar	Cmet	RL	Lr
	(m)	(m)	(m)			(Hz)	dB(A)	dB	dB	(dB)	(dB)	(dB)	(dB)	(dB)	(dB)	(dB)	(dB)	(dB)	(dB)	dB(A)
2600	340410.91	5028556.10	103.20	0	DEN	A	84.5	0.0	0.0	0.0	0.0	65.5	1.6	-1.6	0.0	0.0	8.1	0.0	0.0	10.8
2613	340410.91	5028556.10	103.20	1	DEN	A	84.5	0.0	0.0	0.0	0.0	65.7	1.7	-1.5	0.0	0.0	5.6	0.0	7.3	5.7

Point Source, ISO 9613, Name: "Battery Energy Storage System 268", ID: "I000A!BESS268"																				
Nr.	X	Y	Z	Refl.	DEN	Freq.	Lw	l/a	Optime	K0	Di	Adiv	Aatm	Agr	Afol	Ahous	Abar	Cmet	RL	Lr
	(m)	(m)	(m)			(Hz)	dB(A)	dB	dB	(dB)	(dB)	(dB)	(dB)	(dB)	(dB)	(dB)	(dB)	(dB)	(dB)	dB(A)
2647	340437.06	5028553.21	103.95	0	DEN	A	84.4	0.0	0.0	0.0	0.0	65.5	2.3	-1.8	0.0	0.0	13.7	0.0	0.0	4.8

Point Source, ISO 9613, Name: "Battery Energy Storage System 239", ID: "I0009!BESS239"																				
Nr.	X	Y	Z	Refl.	DEN	Freq.	Lw	l/a	Optime	K0	Di	Adiv	Aatm	Agr	Afol	Ahous	Abar	Cmet	RL	Lr
	(m)	(m)	(m)			(Hz)	dB(A)	dB	dB	(dB)	(dB)	(dB)	(dB)	(dB)	(dB)	(dB)	(dB)	(dB)	(dB)	dB(A)
2673	340486.83	5028542.96	103.95	0	DEN	A	84.4	0.0	0.0	0.0	0.0	65.5	2.3	-2.1	0.0	0.0	5.0	0.0	0.0	13.7
2675	340486.83	5028542.96	103.95	1	DEN	A	84.4	0.0	0.0	0.0	0.0	65.8	2.4	-2.3	0.0	0.0	4.8	0.0	2.6	11.1

Point Source, ISO 9613, Name: "Battery Energy Storage System 242", ID: "I0009!BESS242"																				
Nr.	X	Y	Z	Refl.	DEN	Freq.	Lw	l/a	Optime	K0	Di	Adiv	Aatm	Agr	Afol	Ahous	Abar	Cmet	RL	Lr
	(m)	(m)	(m)			(Hz)	dB(A)	dB	dB	(dB)	(dB)	(dB)	(dB)	(dB)	(dB)	(dB)	(dB)	(dB)	(dB)	dB(A)
2702	340495.29	5028541.55	103.95	0	DEN	A	84.4	0.0	0.0	0.0	0.0	65.5	2.3	-2.1	0.0	0.0	5.2	0.0	0.0	13.5
2708	340495.29	5028541.55	103.95	1	DEN	A	84.4	0.0	0.0	0.0	0.0	65.9	2.4	-2.4	0.0	0.0	4.8	0.0	3.8	9.9

Point Source, ISO 9613, Name: "Battery Energy Storage System 265", ID: "I000A!BESS265"																				
Nr.	X	Y	Z	Refl.	DEN	Freq.	Lw	l/a	Optime	K0	Di	Adiv	Aatm	Agr	Afol	Ahous	Abar	Cmet	RL	Lr
	(m)	(m)	(m)			(Hz)	dB(A)	dB	dB	(dB)	(dB)	(dB)	(dB)	(dB)	(dB)	(dB)	(dB)	(dB)	(dB)	dB(A)
2741	340428.60	5028554.63	103.95	0	DEN	A	84.4	0.0	0.0	0.0	0.0	65.5	2.3	-1.8	0.0	0.0	10.5	0.0	0.0	7.9

Point Source, ISO 9613, Name: "Medium Voltage Substation 067", ID: "I02!MVT067"																				
Nr.	X	Y	Z	Refl.	DEN	Freq.	Lw	l/a	Optime	K0	Di	Adiv	Aatm	Agr	Afol	Ahous	Abar	Cmet	RL	Lr
	(m)	(m)	(m)			(Hz)	dB(A)	dB	dB	(dB)	(dB)	(dB)	(dB)	(dB)	(dB)	(dB)	(dB)	(dB)	(dB)	dB(A)
2774	340417.92	5028552.13	103.20	0	DEN	A	84.5	0.0	0.0	0.0	0.0	65.6	1.6	-1.5	0.0	0.0	8.1	0.0	0.0	10.7
2780	340417.92	5028552.13	103.20	1	DEN	A	84.5	0.0	0.0	0.0	0.0	65.8	1.7	-1.6	0.0	0.0	5.6	0.0	7.3	5.7

Point Source, ISO 9613, Name: "Battery Energy Storage System 272", ID: "I000A!BESS272"																				
Nr.	X	Y	Z	Refl.	DEN	Freq.	Lw	l/a	Optime	K0	Di	Adiv	Aatm	Agr	Afol	Ahous	Abar	Cmet	RL	Lr
	(m)	(m)	(m)			(Hz)	dB(A)	dB	dB	(dB)	(dB)	(dB)	(dB)	(dB)	(dB)	(dB)	(dB)	(dB)	(dB)	dB(A)
2816	340444.07	5028549.24	103.95	0	DEN	A	84.4	0.0	0.0	0.0	0.0	65.5	2.3	-1.9	0.0	0.0	13.6	0.0	0.0	4.9

Point Source, ISO 9613, Name: "Battery Energy Storage System 269", ID: "I000A!BESS269"																				
Nr.	X	Y	Z	Refl.	DEN	Freq.	Lw	l/a	Optime	K0	Di	Adiv	Aatm	Agr	Afol	Ahous	Abar	Cmet	RL	Lr
	(m)	(m)	(m)			(Hz)	dB(A)	dB	dB	(dB)	(dB)	(dB)	(dB)	(dB)	(dB)	(dB)	(dB)	(dB)	(dB)	dB(A)
2835	340435.61	5028550.65	103.95	0	DEN	A	84.4	0.0	0.0	0.0	0.0	65.5	2.3	-1.9	0.0	0.0	10.4	0.0	0.0	8.0

Point Source, ISO 9613, Name: "Battery Energy Storage System 243", ID: "I0009!BESS243"																				
Nr.	X	Y	Z	Refl.	DEN	Freq.	Lw	l/a	Optime	K0	Di	Adiv	Aatm	Agr	Afol	Ahous	Abar	Cmet	RL	Lr
	(m)	(m)	(m)			(Hz)	dB(A)	dB	dB	(dB)	(dB)	(dB)	(dB)	(dB)	(dB)	(dB)	(dB)	(dB)	(dB)	dB(A)
2863	340493.84	5028538.99	103.95	0	DEN	A	84.4	0.0	0.0	0.0	0.0	65.5	2.3	-2.1	0.0	0.0	5.0	0.0	0.0	13.7
2865	340493.84	5028538.99	103.95	1	DEN	A	84.4	0.0	0.0	0.0	0.0	65.9	2.4	-2.3	0.0	0.0	4.8	0.0	2.6	11.1

Point Source, ISO 9613, Name: "Medium Voltage Substation 068", ID: "I02!MVT068"																				
Nr.	X	Y	Z	Refl.	DEN	Freq.	Lw	l/a	Optime	K0	Di	Adiv	Aatm	Agr	Afol	Ahous	Abar	Cmet	RL	Lr
	(m)	(m)	(m)			(Hz)	dB(A)	dB	dB	(dB)	(dB)	(dB)	(dB)	(dB)	(dB)	(dB)	(dB)	(dB)	(dB)	dB(A)
2902	340424.93	5028548.16	103.20	0	DEN	A	84.5	0.0	0.0	0.0	0.0	65.6	1.7	-1.5	0.0	0.0	8.1	0.0	0.0	10.7
2910	340424.93	5028548.16	103.20	1	DEN	A	84.5	0.0	0.0	0.0	0.0	65.8	1.7	-1.6	0.0	0.0	5.6	0.0	7.3	5.7

Point Source, ISO 9613, Name: "Battery Energy Storage System 276", ID: "I000A!BESS276"																				
Nr.	X	Y	Z	Refl.	DEN	Freq.	Lw	l/a	Optime	K0	Di	Adiv	Aatm	Agr	Afol	Ahous	Abar	Cmet	RL	Lr
	(m)	(m)	(m)			(Hz)	dB(A)	dB	dB	(dB)	(dB)	(dB)	(dB)	(dB)	(dB)	(dB)	(dB)	(dB)	(dB)	dB(A)
2943	340451.08	5028545.26	103.95	0	DEN	A	84.4	0.0	0.0	0.0	0.0	65.5	2.3	-2.0	0.0	0.0	13.6	0.0	0.0	5.0

Point Source, ISO 9613, Name: "Battery Energy Storage System 273", ID: "I000A!BESS273"																				
Nr.	X	Y	Z	Refl.	DEN	Freq.	Lw	l/a	Optime	K0	Di	Adiv	Aatm	Agr	Afol	Ahous	Abar	Cmet	RL	Lr
	(m)	(m)	(m)			(Hz)	dB(A)	dB	dB	(dB)	(dB)	(dB)	(dB)	(dB)	(dB)	(dB)	(dB)	(dB)	(dB)	dB(A)
2967	340442.62	5028546.68	103.95	0	DEN	A	84.4	0.0	0.0	0.0	0.0	65.5	2.3	-2.0	0.0	0.0	10.4	0.0	0.0	8.1

Sample Calculation at POR3 - Regular Operations

Point Source, ISO 9613, Name: "Medium Voltage Substation 069", ID: "I02!MVT069"																				
Nr.	X	Y	Z	Refl.	DEN	Freq.	Lw	l/a	Optime	K0	Di	Adiv	Aatm	Agr	Afol	Ahous	Abar	Cmet	RL	Lr
	(m)	(m)	(m)			(Hz)	dB(A)	dB	dB	(dB)	(dB)	(dB)	(dB)	(dB)	(dB)	(dB)	(dB)	(dB)	(dB)	dB(A)
2996	340431.94	5028544.18	103.20	0	DEN	A	84.5	0.0	0.0	0.0	0.0	65.6	1.7	-1.6	0.0	0.0	8.0	0.0	0.0	10.8
3009	340431.94	5028544.18	103.20	1	DEN	A	84.5	0.0	0.0	0.0	0.0	65.8	1.7	-1.6	0.0	0.0	5.6	0.0	7.2	5.7

Point Source, ISO 9613, Name: "Battery Energy Storage System 246", ID: "I000B!BESS246"																				
Nr.	X	Y	Z	Refl.	DEN	Freq.	Lw	l/a	Optime	K0	Di	Adiv	Aatm	Agr	Afol	Ahous	Abar	Cmet	RL	Lr
	(m)	(m)	(m)			(Hz)	dB(A)	dB	dB	(dB)	(dB)	(dB)	(dB)	(dB)	(dB)	(dB)	(dB)	(dB)	(dB)	dB(A)
3029	340386.22	5028561.56	103.95	0	DEN	A	84.4	0.0	0.0	0.0	0.0	65.6	2.3	-1.7	0.0	0.0	2.9	0.0	0.0	15.4

Point Source, ISO 9613, Name: "Battery Energy Storage System 280", ID: "I000A!BESS280"																				
Nr.	X	Y	Z	Refl.	DEN	Freq.	Lw	l/a	Optime	K0	Di	Adiv	Aatm	Agr	Afol	Ahous	Abar	Cmet	RL	Lr
	(m)	(m)	(m)			(Hz)	dB(A)	dB	dB	(dB)	(dB)	(dB)	(dB)	(dB)	(dB)	(dB)	(dB)	(dB)	(dB)	dB(A)
3042	340458.09	5028541.29	103.95	0	DEN	A	84.4	0.0	0.0	0.0	0.0	65.6	2.3	-2.1	0.0	0.0	13.6	0.0	0.0	5.0

Point Source, ISO 9613, Name: "Battery Energy Storage System 277", ID: "I000A!BESS277"																				
Nr.	X	Y	Z	Refl.	DEN	Freq.	Lw	l/a	Optime	K0	Di	Adiv	Aatm	Agr	Afol	Ahous	Abar	Cmet	RL	Lr
	(m)	(m)	(m)			(Hz)	dB(A)	dB	dB	(dB)	(dB)	(dB)	(dB)	(dB)	(dB)	(dB)	(dB)	(dB)	(dB)	dB(A)
3073	340449.63	5028542.70	103.95	0	DEN	A	84.4	0.0	0.0	0.0	0.0	65.6	2.3	-2.1	0.0	0.0	10.4	0.0	0.0	8.2

Point Source, ISO 9613, Name: "Medium Voltage Substation 070", ID: "I02!MVT070"																				
Nr.	X	Y	Z	Refl.	DEN	Freq.	Lw	l/a	Optime	K0	Di	Adiv	Aatm	Agr	Afol	Ahous	Abar	Cmet	RL	Lr
	(m)	(m)	(m)			(Hz)	dB(A)	dB	dB	(dB)	(dB)	(dB)	(dB)	(dB)	(dB)	(dB)	(dB)	(dB)	(dB)	dB(A)
3091	340438.95	5028540.21	103.20	0	DEN	A	84.5	0.0	0.0	0.0	0.0	65.7	1.7	-1.7	0.0	0.0	8.0	0.0	0.0	10.9
3097	340438.95	5028540.21	103.20	1	DEN	A	84.5	0.0	0.0	0.0	0.0	65.8	1.7	-1.7	0.0	0.0	5.5	0.0	7.3	5.9

Point Source, ISO 9613, Name: "Battery Energy Storage System 250", ID: "I000B!BESS250"																				
Nr.	X	Y	Z	Refl.	DEN	Freq.	Lw	l/a	Optime	K0	Di	Adiv	Aatm	Agr	Afol	Ahous	Abar	Cmet	RL	Lr
	(m)	(m)	(m)			(Hz)	dB(A)	dB	dB	(dB)	(dB)	(dB)	(dB)	(dB)	(dB)	(dB)	(dB)	(dB)	(dB)	dB(A)
3117	340393.23	5028557.58	103.95	0	DEN	A	84.4	0.0	0.0	0.0	0.0	65.6	2.3	-1.8	0.0	0.0	5.0	0.0	0.0	13.3

Point Source, ISO 9613, Name: "Battery Energy Storage System 284", ID: "I000A!BESS284"																				
Nr.	X	Y	Z	Refl.	DEN	Freq.	Lw	l/a	Optime	K0	Di	Adiv	Aatm	Agr	Afol	Ahous	Abar	Cmet	RL	Lr
	(m)	(m)	(m)			(Hz)	dB(A)	dB	dB	(dB)	(dB)	(dB)	(dB)	(dB)	(dB)	(dB)	(dB)	(dB)	(dB)	dB(A)
3134	340465.10	5028537.31	103.95	0	DEN	A	84.4	0.0	0.0	0.0	0.0	65.6	2.3	-2.2	0.0	0.0	13.6	0.0	0.0	5.1

Point Source, ISO 9613, Name: "Medium Voltage Substation 071", ID: "I02!MVT071"																				
Nr.	X	Y	Z	Refl.	DEN	Freq.	Lw	l/a	Optime	K0	Di	Adiv	Aatm	Agr	Afol	Ahous	Abar	Cmet	RL	Lr
	(m)	(m)	(m)			(Hz)	dB(A)	dB	dB	(dB)	(dB)	(dB)	(dB)	(dB)	(dB)	(dB)	(dB)	(dB)	(dB)	dB(A)
3158	340445.96	5028536.23	103.20	0	DEN	A	84.5	0.0	0.0	0.0	0.0	65.7	1.7	-1.8	0.0	0.0	8.0	0.0	0.0	10.9
3163	340445.96	5028536.23	103.20	1	DEN	A	84.5	0.0	0.0	0.0	0.0	65.9	1.7	-1.8	0.0	0.0	5.5	0.0	7.2	5.9

Point Source, ISO 9613, Name: "Battery Energy Storage System 247", ID: "I000B!BESS247"																				
Nr.	X	Y	Z	Refl.	DEN	Freq.	Lw	l/a	Optime	K0	Di	Adiv	Aatm	Agr	Afol	Ahous	Abar	Cmet	RL	Lr
	(m)	(m)	(m)			(Hz)	dB(A)	dB	dB	(dB)	(dB)	(dB)	(dB)	(dB)	(dB)	(dB)	(dB)	(dB)	(dB)	dB(A)
3181	340384.77	5028559.00	103.95	0	DEN	A	84.4	0.0	0.0	0.0	0.0	65.6	2.3	-1.8	0.0	0.0	2.3	0.0	0.0	15.9

Point Source, ISO 9613, Name: "Battery Energy Storage System 281", ID: "I000A!BESS281"																				
Nr.	X	Y	Z	Refl.	DEN	Freq.	Lw	l/a	Optime	K0	Di	Adiv	Aatm	Agr	Afol	Ahous	Abar	Cmet	RL	Lr
	(m)	(m)	(m)			(Hz)	dB(A)	dB	dB	(dB)	(dB)	(dB)	(dB)	(dB)	(dB)	(dB)	(dB)	(dB)	(dB)	dB(A)
3194	340456.64	5028538.73	103.95	0	DEN	A	84.4	0.0	0.0	0.0	0.0	65.6	2.3	-2.1	0.0	0.0	10.3	0.0	0.0	8.2

Point Source, ISO 9613, Name: "Battery Energy Storage System 254", ID: "I000B!BESS254"																				
Nr.	X	Y	Z	Refl.	DEN	Freq.	Lw	l/a	Optime	K0	Di	Adiv	Aatm	Agr	Afol	Ahous	Abar	Cmet	RL	Lr
	(m)	(m)	(m)			(Hz)	dB(A)	dB	dB	(dB)	(dB)	(dB)	(dB)	(dB)	(dB)	(dB)	(dB)	(dB)	(dB)	dB(A)
3216	340400.24	5028553.61	103.95	0	DEN	A	84.4	0.0	0.0	0.0	0.0	65.6	2.3	-1.8	0.0	0.0	5.3	0.0	0.0	13.0

Point Source, ISO 9613, Name: "Battery Energy Storage System 251", ID: "I000B!BESS251"																				
Nr.	X	Y	Z	Refl.	DEN	Freq.	Lw	l/a	Optime	K0	Di	Adiv	Aatm	Agr	Afol	Ahous	Abar	Cmet	RL	Lr
	(m)	(m)	(m)			(Hz)	dB(A)	dB	dB	(dB)	(dB)	(dB)	(dB)	(dB)	(dB)	(dB)	(dB)	(dB)	(dB)	dB(A)
3239	340391.78	5028555.03	103.95	0	DEN	A	84.4	0.0	0.0	0.0	0.0	65.6	2.3	-1.8	0.0	0.0	4.7	0.0	0.0	13.5

Point Source, ISO 9613, Name: "Battery Energy Storage System 258", ID: "I000B!BESS258"																				
Nr.	X	Y	Z	Refl.	DEN	Freq.	Lw	l/a	Optime	K0	Di	Adiv	Aatm	Agr	Afol	Ahous	Abar	Cmet	RL	Lr
	(m)	(m)	(m)			(Hz)	dB(A)	dB	dB	(dB)	(dB)	(dB)	(dB)	(dB)	(dB)	(dB)	(dB)	(dB)	(dB)	dB(A)
3249	340407.25	5028549.63	103.95	0	DEN	A	84.4	0.0	0.0	0.0	0.0	65.6	2.3	-1.8	0.0	0.0	5.3	0.0	0.0	13.0

Sample Calculation at POR3 - Regular Operations

Point Source, ISO 9613, Name: "Medium Voltage Substation 072", ID: "I02!MVT072"																				
Nr.	X	Y	Z	Refl.	DEN	Freq.	Lw	l/a	Optime	K0	Di	Adiv	Aatm	Agr	Afol	Ahous	Abar	Cmet	RL	Lr
	(m)	(m)	(m)			(Hz)	dB(A)	dB	dB	(dB)	(dB)	(dB)	(dB)	(dB)	(dB)	(dB)	(dB)	(dB)	(dB)	dB(A)
3268	340452.97	5028532.26	103.20	0	DEN	A	84.5	0.0	0.0	0.0	0.0	65.7	1.7	-1.8	0.0	0.0	7.9	0.0	0.0	11.0
3279	340452.97	5028532.26	103.20	1	DEN	A	84.5	0.0	0.0	0.0	0.0	65.9	1.7	-1.9	0.0	0.0	5.5	0.0	7.3	6.0

Point Source, ISO 9613, Name: "Battery Energy Storage System 288", ID: "I000A!BESS288"																				
Nr.	X	Y	Z	Refl.	DEN	Freq.	Lw	l/a	Optime	K0	Di	Adiv	Aatm	Agr	Afol	Ahous	Abar	Cmet	RL	Lr
	(m)	(m)	(m)			(Hz)	dB(A)	dB	dB	(dB)	(dB)	(dB)	(dB)	(dB)	(dB)	(dB)	(dB)	(dB)	(dB)	dB(A)
3294	340472.11	5028533.34	103.95	0	DEN	A	84.4	0.0	0.0	0.0	0.0	65.7	2.3	-2.3	0.0	0.0	13.6	0.0	0.0	5.1

Point Source, ISO 9613, Name: "Battery Energy Storage System 285", ID: "I000A!BESS285"																				
Nr.	X	Y	Z	Refl.	DEN	Freq.	Lw	l/a	Optime	K0	Di	Adiv	Aatm	Agr	Afol	Ahous	Abar	Cmet	RL	Lr
	(m)	(m)	(m)			(Hz)	dB(A)	dB	dB	(dB)	(dB)	(dB)	(dB)	(dB)	(dB)	(dB)	(dB)	(dB)	(dB)	dB(A)
3321	340463.65	5028534.75	103.95	0	DEN	A	84.4	0.0	0.0	0.0	0.0	65.7	2.3	-2.2	0.0	0.0	10.3	0.0	0.0	8.3

Point Source, ISO 9613, Name: "Battery Energy Storage System 255", ID: "I000B!BESS255"																				
Nr.	X	Y	Z	Refl.	DEN	Freq.	Lw	l/a	Optime	K0	Di	Adiv	Aatm	Agr	Afol	Ahous	Abar	Cmet	RL	Lr
	(m)	(m)	(m)			(Hz)	dB(A)	dB	dB	(dB)	(dB)	(dB)	(dB)	(dB)	(dB)	(dB)	(dB)	(dB)	(dB)	dB(A)
3344	340398.79	5028551.05	103.95	0	DEN	A	84.4	0.0	0.0	0.0	0.0	65.7	2.3	-1.8	0.0	0.0	5.1	0.0	0.0	13.1

Point Source, ISO 9613, Name: "Battery Energy Storage System 262", ID: "I000B!BESS262"																				
Nr.	X	Y	Z	Refl.	DEN	Freq.	Lw	l/a	Optime	K0	Di	Adiv	Aatm	Agr	Afol	Ahous	Abar	Cmet	RL	Lr
	(m)	(m)	(m)			(Hz)	dB(A)	dB	dB	(dB)	(dB)	(dB)	(dB)	(dB)	(dB)	(dB)	(dB)	(dB)	(dB)	dB(A)
3360	340414.26	5028545.66	103.95	0	DEN	A	84.4	0.0	0.0	0.0	0.0	65.7	2.3	-1.8	0.0	0.0	5.2	0.0	0.0	12.9

Point Source, ISO 9613, Name: "Battery Energy Storage System 259", ID: "I000B!BESS259"																				
Nr.	X	Y	Z	Refl.	DEN	Freq.	Lw	l/a	Optime	K0	Di	Adiv	Aatm	Agr	Afol	Ahous	Abar	Cmet	RL	Lr
	(m)	(m)	(m)			(Hz)	dB(A)	dB	dB	(dB)	(dB)	(dB)	(dB)	(dB)	(dB)	(dB)	(dB)	(dB)	(dB)	dB(A)
3384	340405.80	5028547.08	103.95	0	DEN	A	84.4	0.0	0.0	0.0	0.0	65.7	2.3	-1.8	0.0	0.0	5.1	0.0	0.0	13.1

Point Source, ISO 9613, Name: "Medium Voltage Substation 073", ID: "I02!MVT073"																				
Nr.	X	Y	Z	Refl.	DEN	Freq.	Lw	l/a	Optime	K0	Di	Adiv	Aatm	Agr	Afol	Ahous	Abar	Cmet	RL	Lr
	(m)	(m)	(m)			(Hz)	dB(A)	dB	dB	(dB)	(dB)	(dB)	(dB)	(dB)	(dB)	(dB)	(dB)	(dB)	(dB)	dB(A)
3411	340459.98	5028528.28	103.20	0	DEN	A	84.5	0.0	0.0	0.0	0.0	65.8	1.7	-1.9	0.0	0.0	7.9	0.0	0.0	11.0
3413	340459.98	5028528.28	103.20	1	DEN	A	84.5	0.0	0.0	0.0	0.0	66.0	1.7	-1.9	0.0	0.0	5.5	0.0	7.2	6.0

Point Source, ISO 9613, Name: "Battery Energy Storage System 292", ID: "I000A!BESS292"																				
Nr.	X	Y	Z	Refl.	DEN	Freq.	Lw	l/a	Optime	K0	Di	Adiv	Aatm	Agr	Afol	Ahous	Abar	Cmet	RL	Lr
	(m)	(m)	(m)			(Hz)	dB(A)	dB	dB	(dB)	(dB)	(dB)	(dB)	(dB)	(dB)	(dB)	(dB)	(dB)	(dB)	dB(A)
3429	340479.12	5028529.37	103.95	0	DEN	A	84.4	0.0	0.0	0.0	0.0	65.7	2.4	-2.3	0.0	0.0	13.5	0.0	0.0	5.1

Point Source, ISO 9613, Name: "Battery Energy Storage System 289", ID: "I000A!BESS289"																				
Nr.	X	Y	Z	Refl.	DEN	Freq.	Lw	l/a	Optime	K0	Di	Adiv	Aatm	Agr	Afol	Ahous	Abar	Cmet	RL	Lr
	(m)	(m)	(m)			(Hz)	dB(A)	dB	dB	(dB)	(dB)	(dB)	(dB)	(dB)	(dB)	(dB)	(dB)	(dB)	(dB)	dB(A)
3448	340470.66	5028530.78	103.95	0	DEN	A	84.4	0.0	0.0	0.0	0.0	65.7	2.4	-2.3	0.0	0.0	10.3	0.0	0.0	8.3

Point Source, ISO 9613, Name: "Battery Energy Storage System 266", ID: "I000B!BESS266"																				
Nr.	X	Y	Z	Refl.	DEN	Freq.	Lw	l/a	Optime	K0	Di	Adiv	Aatm	Agr	Afol	Ahous	Abar	Cmet	RL	Lr
	(m)	(m)	(m)			(Hz)	dB(A)	dB	dB	(dB)	(dB)	(dB)	(dB)	(dB)	(dB)	(dB)	(dB)	(dB)	(dB)	dB(A)
3469	340421.27	5028541.69	103.95	0	DEN	A	84.4	0.0	0.0	0.0	0.0	65.7	2.4	-1.8	0.0	0.0	5.2	0.0	0.0	12.9

Point Source, ISO 9613, Name: "Battery Energy Storage System 263", ID: "I000B!BESS263"																				
Nr.	X	Y	Z	Refl.	DEN	Freq.	Lw	l/a	Optime	K0	Di	Adiv	Aatm	Agr	Afol	Ahous	Abar	Cmet	RL	Lr
	(m)	(m)	(m)			(Hz)	dB(A)	dB	dB	(dB)	(dB)	(dB)	(dB)	(dB)	(dB)	(dB)	(dB)	(dB)	(dB)	dB(A)
3491	340412.81	5028543.10	103.95	0	DEN	A	84.4	0.0	0.0	0.0	0.0	65.7	2.4	-1.8	0.0	0.0	5.1	0.0	0.0	13.1

Point Source, ISO 9613, Name: "Medium Voltage Substation 074", ID: "I02!MVT074"																				
Nr.	X	Y	Z	Refl.	DEN	Freq.	Lw	l/a	Optime	K0	Di	Adiv	Aatm	Agr	Afol	Ahous	Abar	Cmet	RL	Lr
	(m)	(m)	(m)			(Hz)	dB(A)	dB	dB	(dB)	(dB)	(dB)	(dB)	(dB)	(dB)	(dB)	(dB)	(dB)	(dB)	dB(A)
3509	340466.99	5028524.31	103.20	0	DEN	A	84.5	0.0	0.0	0.0	0.0	65.8	1.7	-2.0	0.0	0.0	7.9	0.0	0.0	11.1
3511	340466.99	5028524.31	103.20	1	DEN	A	84.5	0.0	0.0	0.0	0.0	66.0	1.7	-2.0	0.0	0.0	5.5	0.0	7.2	6.1

Point Source, ISO 9613, Name: "Battery Energy Storage System 270", ID: "I000B!BESS270"																				
Nr.	X	Y	Z	Refl.	DEN	Freq.	Lw	l/a	Optime	K0	Di	Adiv	Aatm	Agr	Afol	Ahous	Abar	Cmet	RL	Lr
	(m)	(m)	(m)			(Hz)	dB(A)	dB	dB	(dB)	(dB)	(dB)	(dB)	(dB)	(dB)	(dB)	(dB)	(dB)	(dB)	dB(A)
3532	340428.28	5028537.71	103.95	0	DEN	A	84.4	0.0	0.0	0.0	0.0	65.7	2.4	-1.8	0.0	0.0	5.2	0.0	0.0	12.9

Sample Calculation at POR3 - Regular Operations

Point Source, ISO 9613, Name: "Battery Energy Storage System 293", ID: "!000A!BESS293"																				
Nr.	X	Y	Z	Refl.	DEN	Freq.	Lw	l/a	Optime	K0	Di	Adiv	Aatm	Agr	Afol	Ahous	Abar	Cmet	RL	Lr
	(m)	(m)	(m)			(Hz)	dB(A)	dB	dB	(dB)	(dB)	(dB)	(dB)	(dB)	(dB)	(dB)	(dB)	(dB)	(dB)	dB(A)
3551	340477.67	5028526.81	103.95	0	DEN	A	84.4	0.0	0.0	0.0	0.0	65.7	2.4	-2.3	0.0	0.0	10.2	0.0	0.0	8.4

Point Source, ISO 9613, Name: "Battery Energy Storage System 296", ID: "!000A!BESS296"																				
Nr.	X	Y	Z	Refl.	DEN	Freq.	Lw	l/a	Optime	K0	Di	Adiv	Aatm	Agr	Afol	Ahous	Abar	Cmet	RL	Lr
	(m)	(m)	(m)			(Hz)	dB(A)	dB	dB	(dB)	(dB)	(dB)	(dB)	(dB)	(dB)	(dB)	(dB)	(dB)	(dB)	dB(A)
3572	340486.13	5028525.39	103.95	0	DEN	A	84.4	0.0	0.0	0.0	0.0	65.7	2.4	-2.3	0.0	0.0	13.5	0.0	0.0	5.1

Point Source, ISO 9613, Name: "Battery Energy Storage System 267", ID: "!000B!BESS267"																				
Nr.	X	Y	Z	Refl.	DEN	Freq.	Lw	l/a	Optime	K0	Di	Adiv	Aatm	Agr	Afol	Ahous	Abar	Cmet	RL	Lr
	(m)	(m)	(m)			(Hz)	dB(A)	dB	dB	(dB)	(dB)	(dB)	(dB)	(dB)	(dB)	(dB)	(dB)	(dB)	(dB)	dB(A)
3593	340419.82	5028539.13	103.95	0	DEN	A	84.4	0.0	0.0	0.0	0.0	65.8	2.4	-1.8	0.0	0.0	5.0	0.0	0.0	13.1

Point Source, ISO 9613, Name: "Battery Energy Storage System 274", ID: "!000B!BESS274"																				
Nr.	X	Y	Z	Refl.	DEN	Freq.	Lw	l/a	Optime	K0	Di	Adiv	Aatm	Agr	Afol	Ahous	Abar	Cmet	RL	Lr
	(m)	(m)	(m)			(Hz)	dB(A)	dB	dB	(dB)	(dB)	(dB)	(dB)	(dB)	(dB)	(dB)	(dB)	(dB)	(dB)	dB(A)
3616	340435.29	5028533.74	103.95	0	DEN	A	84.4	0.0	0.0	0.0	0.0	65.8	2.4	-1.9	0.0	0.0	5.2	0.0	0.0	13.0

Point Source, ISO 9613, Name: "Medium Voltage Substation 075", ID: "!02!MVT075"																				
Nr.	X	Y	Z	Refl.	DEN	Freq.	Lw	l/a	Optime	K0	Di	Adiv	Aatm	Agr	Afol	Ahous	Abar	Cmet	RL	Lr
	(m)	(m)	(m)			(Hz)	dB(A)	dB	dB	(dB)	(dB)	(dB)	(dB)	(dB)	(dB)	(dB)	(dB)	(dB)	(dB)	dB(A)
3633	340474.00	5028520.33	103.20	0	DEN	A	84.5	0.0	0.0	0.0	0.0	65.9	1.7	-2.0	0.0	0.0	7.8	0.0	0.0	11.1
3635	340474.00	5028520.33	103.20	1	DEN	A	84.5	0.0	0.0	0.0	0.0	66.0	1.7	-2.1	0.0	0.0	5.4	0.0	7.2	6.1

Point Source, ISO 9613, Name: "Battery Energy Storage System 271", ID: "!000B!BESS271"																				
Nr.	X	Y	Z	Refl.	DEN	Freq.	Lw	l/a	Optime	K0	Di	Adiv	Aatm	Agr	Afol	Ahous	Abar	Cmet	RL	Lr
	(m)	(m)	(m)			(Hz)	dB(A)	dB	dB	(dB)	(dB)	(dB)	(dB)	(dB)	(dB)	(dB)	(dB)	(dB)	(dB)	dB(A)
3649	340426.83	5028535.16	103.95	0	DEN	A	84.4	0.0	0.0	0.0	0.0	65.8	2.4	-1.9	0.0	0.0	5.0	0.0	0.0	13.1

Point Source, ISO 9613, Name: "Battery Energy Storage System 297", ID: "!000A!BESS297"																				
Nr.	X	Y	Z	Refl.	DEN	Freq.	Lw	l/a	Optime	K0	Di	Adiv	Aatm	Agr	Afol	Ahous	Abar	Cmet	RL	Lr
	(m)	(m)	(m)			(Hz)	dB(A)	dB	dB	(dB)	(dB)	(dB)	(dB)	(dB)	(dB)	(dB)	(dB)	(dB)	(dB)	dB(A)
3667	340484.68	5028522.83	103.95	0	DEN	A	84.4	0.0	0.0	0.0	0.0	65.8	2.4	-2.3	0.0	0.0	10.2	0.0	0.0	8.4

Point Source, ISO 9613, Name: "Battery Energy Storage System 300", ID: "!000A!BESS300"																				
Nr.	X	Y	Z	Refl.	DEN	Freq.	Lw	l/a	Optime	K0	Di	Adiv	Aatm	Agr	Afol	Ahous	Abar	Cmet	RL	Lr
	(m)	(m)	(m)			(Hz)	dB(A)	dB	dB	(dB)	(dB)	(dB)	(dB)	(dB)	(dB)	(dB)	(dB)	(dB)	(dB)	dB(A)
3687	340493.14	5028521.42	103.95	0	DEN	A	84.4	0.0	0.0	0.0	0.0	65.8	2.4	-2.3	0.0	0.0	13.5	0.0	0.0	5.0

Point Source, ISO 9613, Name: "Battery Energy Storage System 278", ID: "!000B!BESS278"																				
Nr.	X	Y	Z	Refl.	DEN	Freq.	Lw	l/a	Optime	K0	Di	Adiv	Aatm	Agr	Afol	Ahous	Abar	Cmet	RL	Lr
	(m)	(m)	(m)			(Hz)	dB(A)	dB	dB	(dB)	(dB)	(dB)	(dB)	(dB)	(dB)	(dB)	(dB)	(dB)	(dB)	dB(A)
3707	340442.29	5028529.76	103.95	0	DEN	A	84.4	0.0	0.0	0.0	0.0	65.8	2.4	-2.1	0.0	0.0	5.2	0.0	0.0	13.1

Point Source, ISO 9613, Name: "Battery Energy Storage System 275", ID: "!000B!BESS275"																				
Nr.	X	Y	Z	Refl.	DEN	Freq.	Lw	l/a	Optime	K0	Di	Adiv	Aatm	Agr	Afol	Ahous	Abar	Cmet	RL	Lr
	(m)	(m)	(m)			(Hz)	dB(A)	dB	dB	(dB)	(dB)	(dB)	(dB)	(dB)	(dB)	(dB)	(dB)	(dB)	(dB)	dB(A)
3723	340433.84	5028531.18	103.95	0	DEN	A	84.4	0.0	0.0	0.0	0.0	65.8	2.4	-2.0	0.0	0.0	5.0	0.0	0.0	13.2

Point Source, ISO 9613, Name: "Medium Voltage Substation 076", ID: "!02!MVT076"																				
Nr.	X	Y	Z	Refl.	DEN	Freq.	Lw	l/a	Optime	K0	Di	Adiv	Aatm	Agr	Afol	Ahous	Abar	Cmet	RL	Lr
	(m)	(m)	(m)			(Hz)	dB(A)	dB	dB	(dB)	(dB)	(dB)	(dB)	(dB)	(dB)	(dB)	(dB)	(dB)	(dB)	dB(A)
3743	340481.01	5028516.36	103.20	0	DEN	A	84.5	0.0	0.0	0.0	0.0	65.9	1.7	-2.1	0.0	0.0	7.8	0.0	0.0	11.2
3746	340481.01	5028516.36	103.20	1	DEN	A	84.5	0.0	0.0	0.0	0.0	66.1	1.7	-2.2	0.0	0.0	5.4	0.0	7.2	6.2

Point Source, ISO 9613, Name: "Battery Energy Storage System 301", ID: "!000A!BESS301"																				
Nr.	X	Y	Z	Refl.	DEN	Freq.	Lw	l/a	Optime	K0	Di	Adiv	Aatm	Agr	Afol	Ahous	Abar	Cmet	RL	Lr
	(m)	(m)	(m)			(Hz)	dB(A)	dB	dB	(dB)	(dB)	(dB)	(dB)	(dB)	(dB)	(dB)	(dB)	(dB)	(dB)	dB(A)
3759	340491.69	5028518.86	103.95	0	DEN	A	84.4	0.0	0.0	0.0	0.0	65.8	2.4	-2.3	0.0	0.0	10.2	0.0	0.0	8.4

Point Source, ISO 9613, Name: "Battery Energy Storage System 282", ID: "!000B!BESS282"																				
Nr.	X	Y	Z	Refl.	DEN	Freq.	Lw	l/a	Optime	K0	Di	Adiv	Aatm	Agr	Afol	Ahous	Abar	Cmet	RL	Lr
	(m)	(m)	(m)			(Hz)	dB(A)	dB	dB	(dB)	(dB)	(dB)	(dB)	(dB)	(dB)	(dB)	(dB)	(dB)	(dB)	dB(A)
3774	340449.30	5028525.79	103.95	0	DEN	A	84.4	0.0	0.0	0.0	0.0	65.8	2.4	-2.1	0.0	0.0	5.2	0.0	0.0	13.1

Sample Calculation at POR3 - Regular Operations

Point Source, ISO 9613, Name: "Battery Energy Storage System 279", ID: "!000B!BESS279"																				
Nr.	X	Y	Z	Refl.	DEN	Freq.	Lw	l/a	Optime	K0	Di	Adiv	Aatm	Agr	Afol	Ahous	Abar	Cmet	RL	Lr
	(m)	(m)	(m)			(Hz)	dB(A)	dB	dB	(dB)	(dB)	(dB)	(dB)	(dB)	(dB)	(dB)	(dB)	(dB)	(dB)	dB(A)
3792	340440.85	5028527.21	103.95	0	DEN	A	84.4	0.0	0.0	0.0	0.0	65.9	2.4	-2.1	0.0	0.0	5.0	0.0	0.0	13.2

Point Source, ISO 9613, Name: "Medium Voltage Substation 077", ID: "!02!MVT077"																				
Nr.	X	Y	Z	Refl.	DEN	Freq.	Lw	l/a	Optime	K0	Di	Adiv	Aatm	Agr	Afol	Ahous	Abar	Cmet	RL	Lr
	(m)	(m)	(m)			(Hz)	dB(A)	dB	dB	(dB)	(dB)	(dB)	(dB)	(dB)	(dB)	(dB)	(dB)	(dB)	(dB)	dB(A)
3812	340488.02	5028512.39	103.20	0	DEN	A	84.5	0.0	0.0	0.0	0.0	65.9	1.7	-2.1	0.0	0.0	7.6	0.0	0.0	11.3
3818	340488.02	5028512.39	103.20	1	DEN	A	84.5	0.0	0.0	0.0	0.0	66.1	1.7	-2.1	0.0	0.0	5.4	0.0	7.2	6.2

Point Source, ISO 9613, Name: "Battery Energy Storage System 286", ID: "!000B!BESS286"																				
Nr.	X	Y	Z	Refl.	DEN	Freq.	Lw	l/a	Optime	K0	Di	Adiv	Aatm	Agr	Afol	Ahous	Abar	Cmet	RL	Lr
	(m)	(m)	(m)			(Hz)	dB(A)	dB	dB	(dB)	(dB)	(dB)	(dB)	(dB)	(dB)	(dB)	(dB)	(dB)	(dB)	dB(A)
3830	340456.31	5028521.81	103.95	0	DEN	A	84.4	0.0	0.0	0.0	0.0	65.9	2.4	-2.2	0.0	0.0	5.2	0.0	0.0	13.2

Point Source, ISO 9613, Name: "Battery Energy Storage System 283", ID: "!000B!BESS283"																				
Nr.	X	Y	Z	Refl.	DEN	Freq.	Lw	l/a	Optime	K0	Di	Adiv	Aatm	Agr	Afol	Ahous	Abar	Cmet	RL	Lr
	(m)	(m)	(m)			(Hz)	dB(A)	dB	dB	(dB)	(dB)	(dB)	(dB)	(dB)	(dB)	(dB)	(dB)	(dB)	(dB)	dB(A)
3846	340447.86	5028523.23	103.95	0	DEN	A	84.4	0.0	0.0	0.0	0.0	65.9	2.4	-2.2	0.0	0.0	5.0	0.0	0.0	13.3

Point Source, ISO 9613, Name: "Battery Energy Storage System 290", ID: "!000B!BESS290"																				
Nr.	X	Y	Z	Refl.	DEN	Freq.	Lw	l/a	Optime	K0	Di	Adiv	Aatm	Agr	Afol	Ahous	Abar	Cmet	RL	Lr
	(m)	(m)	(m)			(Hz)	dB(A)	dB	dB	(dB)	(dB)	(dB)	(dB)	(dB)	(dB)	(dB)	(dB)	(dB)	(dB)	dB(A)
3863	340463.32	5028517.84	103.95	0	DEN	A	84.4	0.0	0.0	0.0	0.0	65.9	2.4	-2.3	0.0	0.0	5.2	0.0	0.0	13.2

Point Source, ISO 9613, Name: "Battery Energy Storage System 287", ID: "!000B!BESS287"																				
Nr.	X	Y	Z	Refl.	DEN	Freq.	Lw	l/a	Optime	K0	Di	Adiv	Aatm	Agr	Afol	Ahous	Abar	Cmet	RL	Lr
	(m)	(m)	(m)			(Hz)	dB(A)	dB	dB	(dB)	(dB)	(dB)	(dB)	(dB)	(dB)	(dB)	(dB)	(dB)	(dB)	dB(A)
3876	340454.87	5028519.26	103.95	0	DEN	A	84.4	0.0	0.0	0.0	0.0	65.9	2.4	-2.2	0.0	0.0	5.0	0.0	0.0	13.3

Point Source, ISO 9613, Name: "Battery Energy Storage System 294", ID: "!000B!BESS294"																				
Nr.	X	Y	Z	Refl.	DEN	Freq.	Lw	l/a	Optime	K0	Di	Adiv	Aatm	Agr	Afol	Ahous	Abar	Cmet	RL	Lr
	(m)	(m)	(m)			(Hz)	dB(A)	dB	dB	(dB)	(dB)	(dB)	(dB)	(dB)	(dB)	(dB)	(dB)	(dB)	(dB)	dB(A)
3891	340470.33	5028513.86	103.95	0	DEN	A	84.4	0.0	0.0	0.0	0.0	66.0	2.4	-2.3	0.0	0.0	5.1	0.0	0.0	13.2

Point Source, ISO 9613, Name: "Battery Energy Storage System 291", ID: "!000B!BESS291"																				
Nr.	X	Y	Z	Refl.	DEN	Freq.	Lw	l/a	Optime	K0	Di	Adiv	Aatm	Agr	Afol	Ahous	Abar	Cmet	RL	Lr
	(m)	(m)	(m)			(Hz)	dB(A)	dB	dB	(dB)	(dB)	(dB)	(dB)	(dB)	(dB)	(dB)	(dB)	(dB)	(dB)	dB(A)
3900	340461.87	5028515.28	103.95	0	DEN	A	84.4	0.0	0.0	0.0	0.0	66.0	2.4	-2.3	0.0	0.0	5.0	0.0	0.0	13.3

Point Source, ISO 9613, Name: "Battery Energy Storage System 295", ID: "!000B!BESS295"																				
Nr.	X	Y	Z	Refl.	DEN	Freq.	Lw	l/a	Optime	K0	Di	Adiv	Aatm	Agr	Afol	Ahous	Abar	Cmet	RL	Lr
	(m)	(m)	(m)			(Hz)	dB(A)	dB	dB	(dB)	(dB)	(dB)	(dB)	(dB)	(dB)	(dB)	(dB)	(dB)	(dB)	dB(A)
3911	340468.88	5028511.31	103.95	0	DEN	A	84.4	0.0	0.0	0.0	0.0	66.0	2.4	-2.3	0.0	0.0	5.0	0.0	0.0	13.3

Point Source, ISO 9613, Name: "Battery Energy Storage System 298", ID: "!000B!BESS298"																				
Nr.	X	Y	Z	Refl.	DEN	Freq.	Lw	l/a	Optime	K0	Di	Adiv	Aatm	Agr	Afol	Ahous	Abar	Cmet	RL	Lr
	(m)	(m)	(m)			(Hz)	dB(A)	dB	dB	(dB)	(dB)	(dB)	(dB)	(dB)	(dB)	(dB)	(dB)	(dB)	(dB)	dB(A)
3923	340477.34	5028509.89	103.95	0	DEN	A	84.4	0.0	0.0	0.0	0.0	66.0	2.4	-2.3	0.0	0.0	5.1	0.0	0.0	13.2

Point Source, ISO 9613, Name: "Battery Energy Storage System 299", ID: "!000B!BESS299"																				
Nr.	X	Y	Z	Refl.	DEN	Freq.	Lw	l/a	Optime	K0	Di	Adiv	Aatm	Agr	Afol	Ahous	Abar	Cmet	RL	Lr
	(m)	(m)	(m)			(Hz)	dB(A)	dB	dB	(dB)	(dB)	(dB)	(dB)	(dB)	(dB)	(dB)	(dB)	(dB)	(dB)	dB(A)
3927	340475.89	5028507.33	103.95	0	DEN	A	84.4	0.0	0.0	0.0	0.0	66.1	2.4	-2.4	0.0	0.0	5.0	0.0	0.0	13.3

Point Source, ISO 9613, Name: "Battery Energy Storage System 302", ID: "!000B!BESS302"																				
Nr.	X	Y	Z	Refl.	DEN	Freq.	Lw	l/a	Optime	K0	Di	Adiv	Aatm	Agr	Afol	Ahous	Abar	Cmet	RL	Lr
	(m)	(m)	(m)			(Hz)	dB(A)	dB	dB	(dB)	(dB)	(dB)	(dB)	(dB)	(dB)	(dB)	(dB)	(dB)	(dB)	dB(A)
3935	340484.35	5028505.92	103.95	0	DEN	A	84.4	0.0	0.0	0.0	0.0	66.1	2.4	-2.3	0.0	0.0	5.1	0.0	0.0	13.1

Point Source, ISO 9613, Name: "Battery Energy Storage System 303", ID: "!000B!BESS303"																				
Nr.	X	Y	Z	Refl.	DEN	Freq.	Lw	l/a	Optime	K0	Di	Adiv	Aatm	Agr	Afol	Ahous	Abar	Cmet	RL	Lr
	(m)	(m)	(m)			(Hz)	dB(A)	dB	dB	(dB)	(dB)	(dB)	(dB)	(dB)	(dB)	(dB)	(dB)	(dB)	(dB)	dB(A)
3943	340482.90	5028503.36	103.95	0	DEN	A	84.4	0.0	0.0	0.0	0.0	66.1	2.4	-2.4	0.0	0.0	5.0	0.0	0.0	13.3

Sample Calculation at POR3 - Emergency Generator Testing

Receiver
 Name: 3 Storey Residence - 2655 Marchurst Road
 ID: POR3
 X: 340566.18 m
 Y: 5029065.76 m
 Z: 103.12 m

Point Source, ISO 9613, Name: "Emergency Generator", ID: "!05!Gen001"																				
Nr.	X	Y	Z	Refl.	DEN	Freq.	Lw	l/a	Optime	K0	Di	Adiv	Aatm	Agr	Afol	Ahous	Abar	Cmet	RL	Lr
	(m)	(m)	(m)			(Hz)	dB(A)	dB	dB	(dB)	(dB)	(dB)	(dB)	(dB)	(dB)	(dB)	(dB)	(dB)	(dB)	dB(A)
11	340625.47	5028521.93	105.00	0	D	A	99.8	0.0	0.0	0.0	0.0	65.8	1.9	-1.8	0.0	0.0	4.8	0.0	0.0	29.2

