

**Brookfield Renewables
 Owner's Engineer for South March BESS**

**Air Quality Assessment in Emergency Fire Scenario Under Variable
 Weather Scenarios**



			<i>Karch, Julianna</i>	<i>[Signature]</i>	<i>Benoit, Clement</i>	-
2026-02-06	0	Approved for Use	J. Karch	C. Lyons	C. Benoit	-
Date	Rev.	Status	Prepared By	Checked By	Approved By	Approved By
HATCH						Client

IMPORTANT NOTICE TO READER

This report was prepared by Hatch Ltd. ("**Hatch**") for the sole and exclusive use of Brookfield BRP Canada Corp. (the "**Client**") for the purpose of analyzing the potential impacts to local air quality resulting from a thermal runaway of the proposed Battery Energy Storage System (BESS) for the South March BESS project, in Ottawa, Ontario. This report must not be used by the Client for any other purpose, or provided to, relied upon or used by any other person without Hatch's prior written consent.

This report contains the expression of the opinion of Hatch using its professional judgment and reasonable care based on information available and conditions existing at the time of preparation.

The use of, or reliance upon this report is subject to the following:

1. This report is to be read in the context of and subject to the terms of the relevant Project Addendum, P-079047, dated August 1, 2024, between Hatch and the Client (the "**Hatch Agreement**"), including any methodologies, procedures, techniques, assumptions and other relevant terms or conditions specified in the Hatch Agreement;
2. This report is meant to be read as a whole, and sections of the report must not be read or relied upon out of context;
3. This report has been prepared solely for informational purposes. It does not constitute a regulatory submission and should not be interpreted as such, and
4. Unless expressly stated otherwise in this report, Hatch has not verified the accuracy, completeness or validity of any information provided to Hatch by or on behalf of the Client and Hatch does not accept any liability in connection with such information. The inclusion of referenced materials or findings from other studies does not imply certification, endorsement, or professional validation.
5. Given the complexity of a runaway fire event at a BESS and due to a lack of widely available published data and information on air contaminant releases, the methodology applied to estimate air contaminant release rates used in the plume modelling is not standard and is based on several assumptions. As such, there is uncertainty in the release estimates applied in the study.

Table of Contents

1. Project Description..... 1

2. Introduction..... 2

 2.1 Purpose and Scope 2

 2.2 Property and Surrounding Area Description 3

 2.3 Project Description..... 4

 2.4 Reference Reports..... 5

 2.4.1 Sungrow Fire Study..... 5

 2.4.2 Fire Modeling Exercise..... 5

 2.4.3 Emission Summary and Dispersion Modeling Report 5

3. Emergency Scenario, Emission Rate Estimation and Data Quality 6

 3.1 Description of Emergency Scenario 6

 3.2 POI Calculation Methods 6

 3.2.1 Emission Rates 7

 3.2.2 Effective Stack Height 8

 3.2.3 Dispersion Coefficients 9

 3.2.4 POI Calculations 10

 3.2.5 HF Calculations 10

4. Local Meteorological Conditions 11

 4.1 Weather Conditions 11

 4.1.1 Weather Scenarios..... 11

5. POI Concentrations 13

 5.1 Emission Summary Table..... 13

 5.2 HF Results 15

 5.2.1 No Plume Rise 15

 5.2.2 Maximum Plume Rise 15

 5.3 Assessment of Contaminants with no MECP POI Limits 17

 5.4 Averaging Times 18

 5.5 POI Comparison to Previous Assessment 18

6. Conclusions 20

7. References 21

List of Figures

Figure 1-1: Battery Energy Storage System Geometry 3

Figure 1-2: Site Plan Layout..... 4

Figure 2-1: Gaussian Plume Distribution 7

Figure 2-2: Gaussian Pollutant Concentration and Dispersion Profiles..... 9

List of Tables

Table 2-1: Dispersion Coefficient Equations.....	10
Table 3-1: Stability Class Descriptions	11
Table 3-2: Meteorological Conditions Influencing Pasquils Stability Classes.....	12
Table 3-3: Evaluated Scenarios with Minimum and Maximum Wind Speeds	12
Table 4-1: Maximum Predicted Concentrations and Applicable Limits (No Plume Rise Scenario).....	14
Table 4-2: Maximum Predicted Concentrations and Applicable Limits (Plume Rise Scenario)	14
Table 4-3: Maximum Predicted HF Concentrations and Applicable Limits.....	16
Table 4-4: Comparison of Maximum POI Concentrations	18

List of Appendices

Appendix A Result Tables

1. Project Description

Fitzroy BESS Inc., a subsidiary of Evolgen by Brookfield Renewable (Brookfield) in partnership with the Algonquins of Pikwàkanagàn and is proposing to develop the South March Battery Energy Storage System (BESS) Project (the Project). The Project will be in the West Carleton-March Ward in the City of Ottawa, Ontario. The Project is located on two leased parcels of land at 2555 and 2625 Marchurst Road, Ottawa, Ontario, and situated south of Thomas A. Dolan Parkway, west of Marchurst Road, and north of John Aselford Drive. The Project has a Development Area of approximately 9.0 hectares on approximately 84.5 hectares of property. The leased rural lots currently include two residential buildings with an access lane, naturalized areas with woodland and wetland, as well as limited noncommercial pasture use.

The Project is a 250-megawatt (MW) energy storage facility that uses lithium ion (lithium iron phosphate) technology and is designed to store up to 1,000 megawatt hours of energy, providing four hours of continuous discharge at full capacity.

The Project will consist of 256 BESS containers at the start of commercial operations and will progressively increase to 307 BESS containers over the duration of the IESO Offtake Agreement. The additional BESS containers will be added through the augmentation process to maintain the required 250 MW capacity. This process is further detailed within the Augmentation Process Memo.

This report considers the full Augmentation Process (a total of 307 BESS containers). Its findings and conclusions are not affected by any stage of augmentation, from 256 to 307 BESS containers.

2. Introduction

Hatch was retained by Brookfield Renewables to conduct an analysis of potential impacts to local air quality resulting from a thermal runaway of the proposed Battery Energy Storage System (BESS) for the South March project. Brookfield is proposing to develop a site located at 2555 Marchurst Road and 2625 Marchurst Road in Dunrobin, Ontario, west of Ottawa (the "Site"). The proposed development involves the construction of 256 BESS containers, 64 medium voltage transformers, a substation, access roads and associated electrical infrastructure (the "Project"). Over the project life, additional BESS containers and medium voltage transformers will be added for a planned total of 307 BESS container and 77 medium voltage transformers. The Project is directly responding to the Independent Electricity System Operator's (IESO) Long Term 1 (LT1) call for capacity in 2024. The BESS will support the IESO to meet Ontario's growing electricity demand by constructing an energy storage facility. The facility will increase renewable grid capacity and storage, enhance flexible grid operations and provide a low carbon initiative to avoid greenhouse gas emissions by reducing reliance on higher carbon intensive power generation.

2.1 Purpose and Scope

This report builds upon Hatch's previous assessment, "*Battery Energy Storage System (BESS) Thermal Runaway Event Emission Summary and Dispersion Modeling Report,*" by evaluating the influence of local weather patterns on contaminant dispersion. The earlier assessment determined the potential impacts on local air quality resulting from a thermal runaway event at the BESS facility. In this follow-up analysis, the focus is on how worst-case weather conditions could affect contaminant concentrations, with the objective of characterizing potential public and occupational exposure.

The scope of this assessment considers air contaminant releases from a single battery container comprising 48 lithium-ion battery modules, arranged in four modules per rack, as shown in Figure 2-1. Emission estimates for a thermal runaway event are based on the specific chemical composition of the batteries, including electrolyte, cathode, and anode materials. For this analysis, a worst-case scenario is defined as the ignition of all top modules within the container. During such an event, exothermic reactions occur within the battery components, releasing gases such as carbon monoxide (CO), Hydrogen (H₂), various volatile organic compounds (VOCs), Hydrogen Fluoride (HF) and Polycyclic Aromatic Hydrocarbons (PAHs).

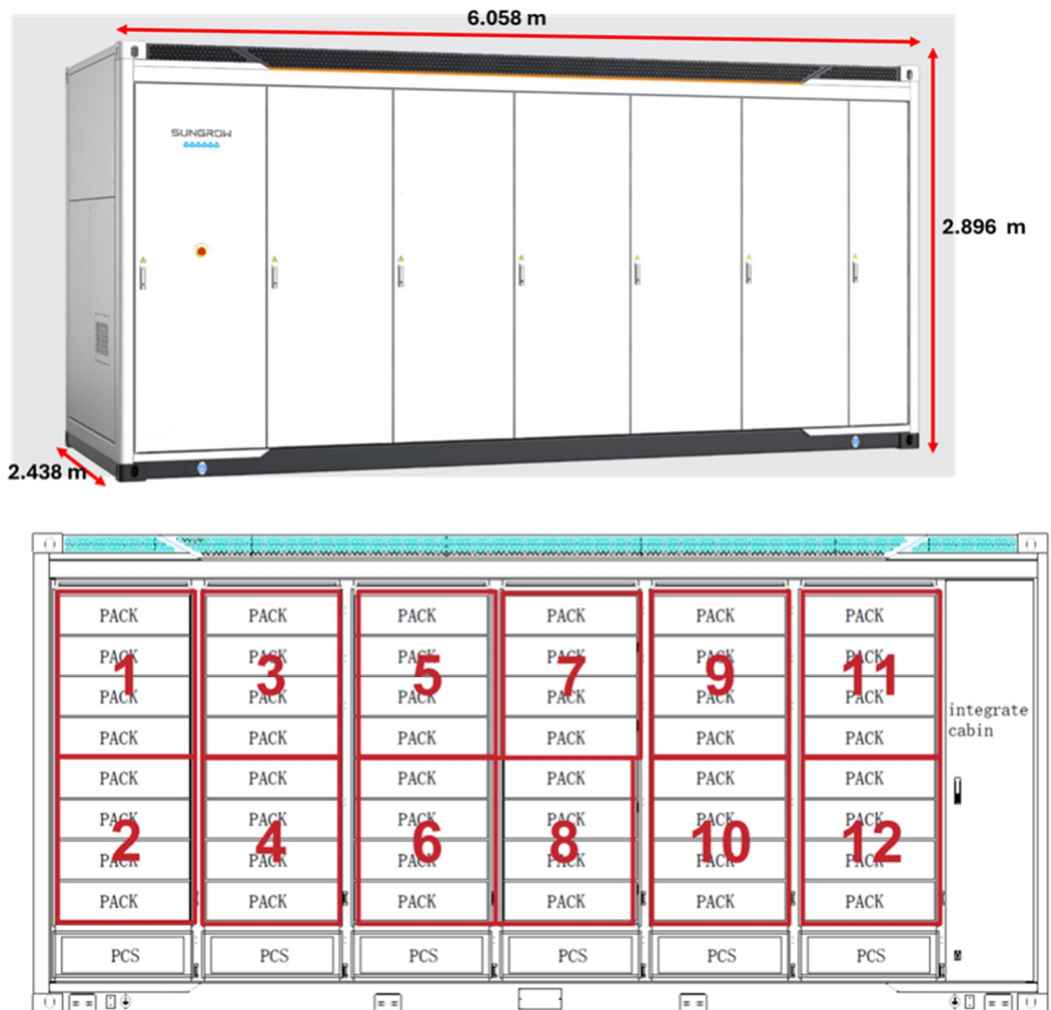

Figure 2-1: Battery Energy Storage System Geometry

2.2 Property and Surrounding Area Description

The Project site is a ~100 acre area located approximately 3.5 kilometers south-southwest of the community of Dunrobin outside of Ottawa. The proposed Project includes development of the Site with a substation, access roads and associated electrical infrastructure. Refer to Figure 2-2 for the Site layout.

The Site is located in an area that is currently zoned as Rural Countryside and includes, according to the City of Ottawa Zoning By-Law 2026-50. The areas surrounding the Site are zoned as Rural Countryside, Environmental Protection and Agricultural areas. Based on a google imagery, the nearest sensitive receptor is located over 100 m from the project's fence line.

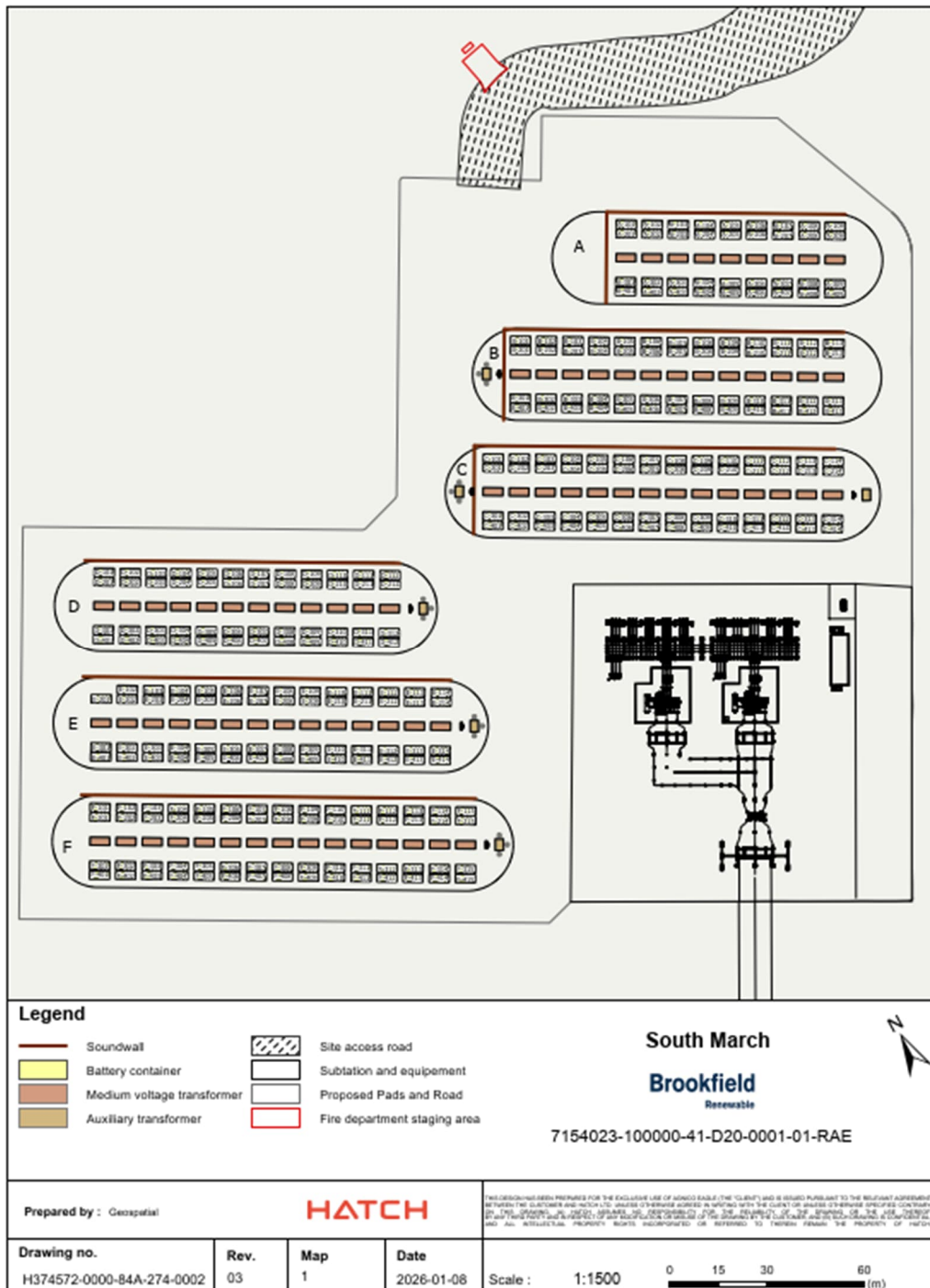

Figure 2-2: Site Plan Layout

2.3 Project Description

This assessment evaluates potential air quality impacts from a thermal runaway event at a Battery Energy Storage System (BESS) facility. The focus is on estimating Point of Impingement (POI) concentrations for key contaminants under worst-case conditions. Unlike previous studies that included plume dispersion modeling, this assessment uses a calculation-based approach applying the Gaussian Plume Equation to determine POI concentrations at specified distances and release heights.

2.4 Reference Reports

2.4.1 *Sungrow Fire Study*

Sungrow Power Supply Co., Ltd. engaged Det Norske Veritas (DNV) to develop a Large Scale Burn Test plan for their PowerTitan 2.0 Full-Size Container BESS system in the Sungrow Fire Study (SFD) report [1]. The test aimed to assess the impact of an extreme battery failure scenario, where multiple cells simultaneously experience thermal runaway, leading to propagation through the module stack and resulting in a significant battery container fire.

The goal of the large-scale burn test was to simulate an extreme battery failure event and evaluate the impact of a fully developed fire within the unit that could be caused by either internal or external factors. The extreme scenario assumed that the majority of cells within a module are triggered into thermal runaway, ensuring a large-scale battery fire ensues.

The results of this report assessed the spread of the event, the temperature of the containers during the fire, the heat flux within the study and the resulting concentrations of a suite of 45 gases downwind of the event (10 m distance and 1 m high).

2.4.2 *Fire Modeling Exercise*

The Fire Modeling Exercise (FME) prepared by Hatch Ld. modeled a thermal runaway event occurring in one single battery container [2]. This study was completed to assess the safety of a lithium battery storage facility by identifying potential contaminants, conducting an emission inventory, and performing fire dynamics modeling to evaluate fire-related hazards, airborne emissions, and their potential impact on the surrounding environment and human health.

The fire modeling software, PyroSim was used for the air emissions modeling of the FME. The emissions of contaminants were assessed using a worst-case scenario. Boundary conditions were defined to simulate an open environment, allowing the unrestricted flow of gases and heat at the top and sides of the fire, while the bottom boundaries were treated as walls. The results of this exercise provided the heat release rate, the maximum temperature and varying contaminant concentrations. The maximum concentration results of CO from the fire simulator were used in this assessment as the maximum POI concentrations with a 1-hour averaging period for the most conservative results.

The modeling process involved simulating these reactions and the subsequent emissions to predict the dispersion patterns and concentrations of these hazardous substances.

2.4.3 *Emission Summary and Dispersion Modeling Report*

The latest assessment conducted by Hatch Ltd. followed the structure of an Emission Summary and Dispersion Modeling (ESDM) report to facilitate comparison of modeled contaminant concentrations against the Ministry of Environment, Conservation and Parks (MECP) guideline POI limits [3]. This analysis incorporated data from two previously referenced studies, the Sungrow fire study and the fire modeling exercise to estimate maximum POI concentrations under worst-case conditions.

3. Emergency Scenario, Emission Rate Estimation and Data Quality

This section provides a description of the emergency scenario used to assess the potential worst-case emissions during a thermal runaway event. The section also outlines the emission estimation methods used.

3.1 Description of Emergency Scenario

For this assessment, a worst-case emergency scenario was defined to represent conditions that could result in the highest emission rates of contaminants of potential concern. This scenario assumes a thermal runaway event within a battery container, leading to propagation through multiple modules and a fully developed fire. Adverse meteorological conditions were also considered to capture the greatest potential off-site impacts.

The scenario integrates findings from three key sources:

- **Sungrow Fire Study (SFD):** Provided large-scale burn test data, including heat flux, container temperatures, and concentrations of 45 contaminants measured downwind of the event [1].
- **Fire Modeling Exercise (FME):** Used PyroSim to simulate fire dynamics, heat release rates, and contaminant dispersion under worst-case conditions [2].
- **ESDM Assessment:** Applied concentrations to evaluate compliance with MECP POI limits [3].

Maximum contaminant concentrations for this assessment were derived from the ESDM report, informed by both the Sungrow test results and PyroSim modeling outputs.

3.2 POI Calculation Methods

The dispersion of contaminants was assessed using the Gaussian Plume equation, which is the basis for regulatory plume models, such as AERMOD. This approach is based on the assumption that pollutant concentration across the plume's cross-section follows a Gaussian (normal) distribution. In other words, it is assumed that the highest concentration occurs along the plume centerline, and concentrations decrease symmetrically away from the center in both the crosswind and vertical directions (Refer to Figure 3-1 for a schematic), i.e., following a normal distribution. The concentrations calculated from the Gaussian equation represent ground-level predictions. This model accounts for emission rate, wind speed, atmospheric dispersion, and effective source height to predict concentrations at various ground-level distances downwind.

The Gaussian Plume equation used in this assessment is presented below.:

$$C(x, y = 0, z = 0) = \frac{Q}{2\pi u \sigma_y \sigma_z} \cdot \exp\left(-\frac{H^2}{2\sigma_z^2}\right)$$

Where:

- $C(x, y = 0, z = 0)$ = concentration at ground level ($\mu\text{g}/\text{m}^3$) at distance x downwind, and assuming concentration at the centerline of the plume ($y=0$)
- Q = emission rate ($\mu\text{g}/\text{s}$)
- u = wind speed (m/s)
- σ_y, σ_z = crosswind and vertical dispersion coefficients (m)
- H = effective stack/source height (m)
- x = downwind distance from the source (m)

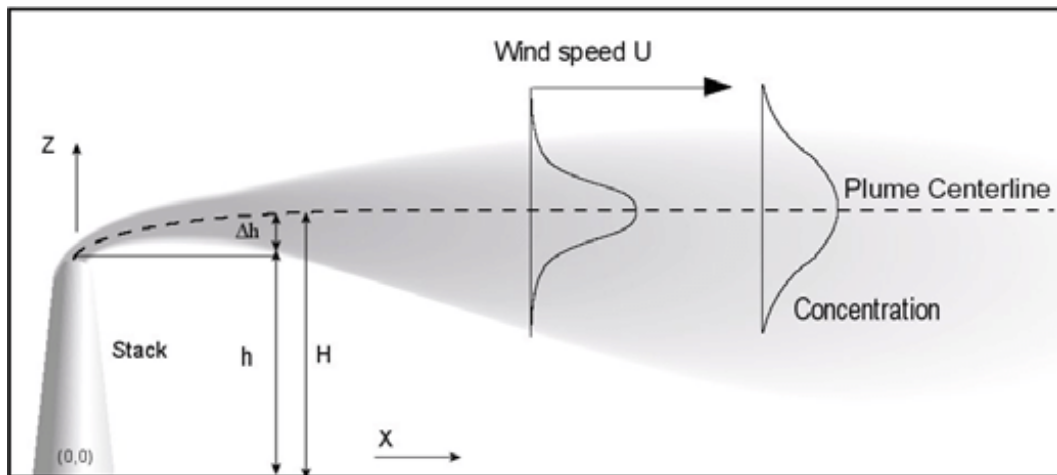

Figure 3-1: Gaussian Plume Distribution

3.2.1 Emission Rates

Emission rates for each contaminant were back calculated using the Gaussian Plume Equation by isolating for Q (emission rate in g/s). Modeled ground-level concentrations from the previous ESDM assessment (based on measured concentrations from the Sungrow Fire Study) served as the basis for these calculations. This approach was used to estimate air contaminant release rates as there is a lack of widely available published data and information on air contaminant releases from a runway fire event at a BESS, e.g., such as published emission factors or other typical estimation approaches. Thus, the methodology applied for the estimated air contaminant release rates used in the plume modelling is not standard and based on several assumptions. As such, there is uncertainty in the release estimates applied in the study.

To calculate emission rates, the following assumptions were applied:

- **Wind Speed:** An average of 1.35 m/s, based on measurements from the Sungrow Fire Study, representing conditions during the testing period (measured winds ranged from 0–2.7 m/s).

- **Atmospheric Stability Class:** Stability Class B was applied to reflect the actual atmospheric conditions during the Sungrow Fire Study (daytime conditions with average wind speeds of 1.35m/s).
- **Effective Stack Height:** The effective release height was assumed to be equal to the battery container height (2.9 m), representing the lowest feasible release height during the fire. Lower release heights produce higher ground-level concentrations because the plume has less vertical distance to rise, disperse and dilute before reaching receptors.

These parameters were applied to calculate emission rates for each contaminant.

3.2.2 **Effective Stack Height**

For scenarios assessed using plume rise, the effective stack height was calculated using the Briggs Buoyancy Plume Rise Equation at standard temperature and pressure [4].

The first step was to compute the Buoyant Heat Flux (F) [4] :

$$F = \frac{gQ_h}{\rho C_p T_a}$$

Where:

- F = Buoyancy Flux Parameter (m⁴/s³)
- Q_h = Heat release rate of fire (J/s)
- g = gravitational acceleration (9.81 m/s²)
- ρ = Density of air (kg/m³)
- C_p = Specific heat capacity of air (J/Kg)
- T_a = Ambient Temperature (K)

The heat release rate was calculated using the heat flux of the fire (130 kW/m²) obtained from the PyroSim study. The area of the fire was assumed to be top layer of battery modules within the container (14.4 m²), resulting in a total heat release rate of 1872000 J/s (W) or 1.872 MW.

$$Q_h = \text{Heat Flux} \left(\frac{\text{kw}}{\text{m}^2} \right) * \text{Area of the Fire (m}^2\text{)}$$

The plume rise (Δh) was then calculated using the Briggs equation. A low wind speed of 1.35 m/s, representing conditions during the Sungrow Fire study was used in this calculation:

$$\Delta h = 2.6 \frac{F^{1/3}}{u}$$

Where:

- Δh = plume rise (m)
- F = Heat release rate of fire (J/s)

- u = wind speed

The effective stack height was calculated by adding the plume rise (Δh) to the battery container height (2.90 m). Refer to Figure 3-2 for a schematic.

$$h_{eff} = \Delta h + \text{Height of Container}$$

Under these conditions the maximum plume rise was calculated to be approximately 10 m above the source.

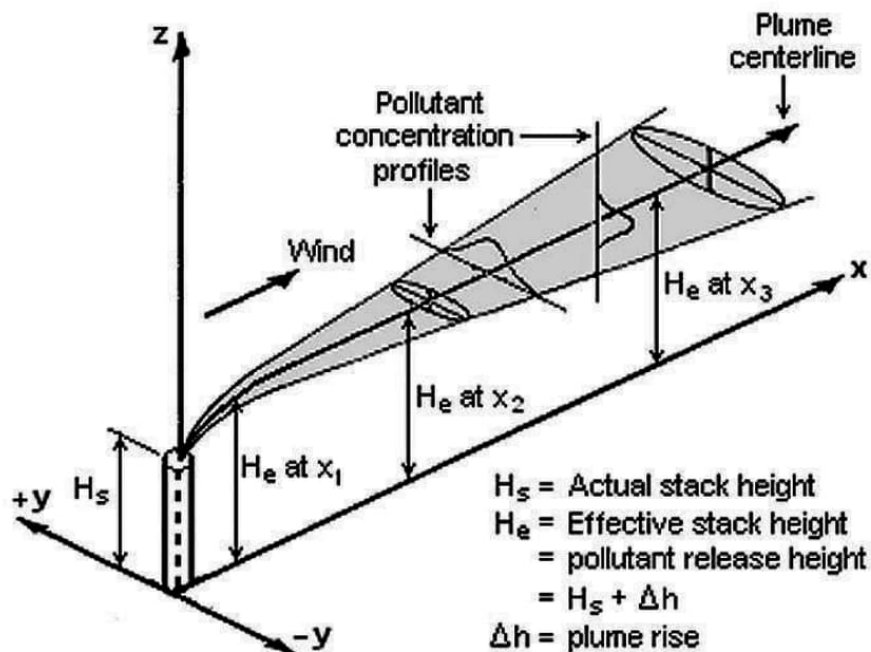

Figure 3-2: Gaussian Pollutant Concentration and Dispersion Profiles

3.2.2.1 Temperatures Effect on Plume Rise

In a fire scenario, ambient temperature has very little effect on plume rise. From the Pyrosim model report, the peak fire temperature reaches 620 °C, while the lowest ambient temperature from the 2024 dataset was -19.3 °C. Because the fire plume temperature is so much higher than the ambient temperature, even large (relative) changes in ambient temperature will have a negligible effect on the temperature difference that drives buoyancy.

In fire scenarios, the buoyancy flux is controlled primarily by the heat release rate (Q_h) and the resulting high plume temperatures of the fire.

3.2.3 Dispersion Coefficients

Dispersion coefficients (σ_y and σ_z) for varying downwind distances were calculated using formulas from the EPA Industrial Source Complex (ISC3) User Guide [5] and summarized in Table 3-1. These coefficients represent the standard deviations (i.e. a measure of how widely concentrations vary around the centreline of the plume): σ_y describes the spread in the crosswind directions, and σ_z in the vertical directions, indicating how the plume

spreads laterally and vertically as it moves downwind. The formulas are based on Pasquill Stability Categories.

Table 3-1: Dispersion Coefficient Equations

Pasquills Stability Category	σ_y	σ_z
A	$0.32x (1 + 0.0004 x)^{-1/2}$	$0.24x (1 + 0.001 x)^{1/2}$
B	$0.32x (1 + 0.0004 x)^{-1/2}$	$0.24x (1 + 0.001 x)^{1/2}$
C	$0.22x (1 + 0.0004 x)^{-1/2}$	0.20x
D	$0.16x (1 + 0.0004 x)^{-1/2}$	$0.14x (1 + 0.0003 x)^{-1/2}$
E	$0.11x (1 + 0.0004 x)^{-1/2}$	$0.08x (1 + 0.0015 x)^{-1/2}$
F	$0.11x (1 + 0.0004 x)^{-1/2}$	$0.08x (1 + 0.0015 x)^{-1/2}$

*x = downwind distance from the source (in meters)

* σ_y, σ_z in meters

3.2.4 POI Calculations

A total of 24 scenarios were assessed to capture all combinations of time of day, wind speed, wind direction, and atmospheric stability class. POI concentrations for each of the 24 scenarios were calculated using the Gaussian Plume Model, based on the emission rates and meteorological conditions defined in this assessment.

Each scenario evaluated 47 contaminants emitted from the thermal runaway event. Carbon Monoxide concentrations were calculated based on data from the Pyrosim model report and HF concentrations were calculated based on a study published in *Scientific Reports* [6].

3.2.5 HF Calculations

HF concentrations were not measured in the Sungrow report, therefore no HF values could be directly extracted from that source. UL9540A Test Method for Evaluating Thermal Runaway Fire Propagation in Battery Energy Storage Systems currently focuses on flammable gasses. HF is not a flammable gas and currently not specifically required by UL9540A to be measured as part of this test. To estimate potential HF emissions, release concentrations were instead obtained from a study published in *Scientific Reports* that examined fluoride gas emissions from lithium-ion battery fires. The study reported that fires involving Lithium Iron Phosphate (LFP) type lithium-ion batteries released an average HF concentration of approximately 50 ppm over the 30-minute test duration [6]. The study was conducted at a smaller scale than the proposed Project, however, for the purposes of this assessment, it was assumed that the HF concentration within the plume remains constant. While the gas volumetric flow rate of emitted contaminants would increase for larger module sizes (resulting in a higher mass emission rates), the plume concentration used for modeling was assumed to remain unchanged. This reflects the expectation that, assuming similar operating and process conditions, HF concentration in the exhaust is primarily governed by process chemistry. In the absence of directly applicable, project-scale concentration measurement, this represents a reasonable and clear assumption for comparison.

4. Local Meteorological Conditions

4.1 Weather Conditions

Hourly weather data for 2024 were obtained from the Environment and Climate Change Canada (ECCC) Historical Data database [7]. Data measured at the Ottawa International Airport station (Climate ID: 6106001) were retrieved. This is the closest available station in the ECCC database to the Project site, located approximately 30 km away. The dataset was used to characterize specific meteorological conditions for the assessment.

4.1.1 Weather Scenarios

Pasquill-Gifford (PG) stability classes were used to characterize the atmospheric stability for each hour of weather data throughout 2024. Atmospheric stability refers to the tendency of the atmosphere to resist or enhance vertical motion, which directly affects how pollutants disperse. Unstable conditions promote strong mixing and rapid dispersion, while stable conditions suppress mixing, causing pollutants to tend to remain concentrated near the surface. These classes, summarized in Table 4-1, range from extremely unstable to extremely stable conditions

Table 4-1: Stability Class Descriptions

Stability Classes	Stability Description
A	Extremely unstable conditions
B	Moderately unstable conditions
C	Slightly unstable conditions
D	Neutral conditions
E	Slightly stable conditions
F	Moderately stable conditions
G	Extremely Stable

The classification for each hour was determined based on three primary factors: wind speed, cloud cover (which influences the amount of solar radiation reaching the surface), and time of day (daytime vs. nighttime). Stability mainly depends on surface heating and wind speeds:

- Daytime conditions with strong solar radiation (clear skies) promote surface heating and thermal convection, resulting in unstable conditions (increased convective mixing in the atmosphere). (Note: Solar radiation at the earth's surface is highest around midday during the summer season, reaching approximately 1000 W/m² [8] under clear skies, which enhances thermal convection compared to winter months).
- As wind speeds increase during clear daytime conditions, mechanical mixing can reduce thermal turbulence and pushes the atmosphere to a more stable stability class.
- Nighttime conditions with clear skies lead to radiative cooling of the surface, reducing turbulence and creating stable conditions (limited vertical mixing).
- Wind speed also plays a critical role: higher wind speeds enhance turbulence, which tends to reduce stability and shift conditions toward unstable (increased mechanical mixing). Conversely, calm winds favor stable conditions.

This classification approach (Table 4-2) was applied to each hour of weather data for the entire year of 2024.

Table 4-2: Meteorological Conditions Influencing Pasquils Stability Classes

Surface Wind Speed (m/s)	Daytime Insolation			Night-time Conditions	
	Strong (Clear, Sunny)	Moderate (Partly Cloudy)	Slight (Very Cloudy)	Thin Overcast/ Low Cloud	Cloudy
<2	A	B	B	E	F
2 to 3	B	B	C	E	F
3 to 5	B	C	C	D	E
5 to 6	C	D	D	D	D
> 6	C	D	D	D	D

A total of 24 scenarios were assessed to capture all combinations of time of day, wind speed, wind direction, and atmospheric stability class. Using hourly meteorological data, the maximum and minimum wind speeds for each scenario were identified to evaluate worst-case concentrations under both low-wind and high-wind conditions (Table 4-3). For this assessment, wind speeds below 3 m/s were classified as low-wind conditions, while those equal to or greater than 3 m/s were classified as high-wind conditions. In scenarios where the minimum wind speed was 0 m/s, the Gaussian dispersion model was not applied because the model assumes continuous plume transport, which is not valid under calm conditions.

Table 4-3: Evaluated Scenarios with Minimum and Maximum Wind Speeds

Scenario	Day/Night	Wind (High/Low)	Wind Direction	Stability Class	Min Wind Speed (m/s)	Max Wind Speed (m/s)
S1	Day	Low	N	B	calm	2.78
S2	Day	Low	N	C	2.22	2.78
S3	Day	Low	S	B	0.83	2.78
S4	Day	Low	S	C	2.22	2.78
S5	Day	Low	E	B	0.83	2.78
S6	Day	Low	E	C	2.22	2.78
S7	Day	Low	W	B	0.83	2.78
S8	Day	Low	W	C	2.22	2.78
S9	Day	High	N	B	3.06	4.72
S10	Day	High	N	D	5.00	10.00
S11	Day	High	S	B	3.06	4.72
S12	Day	High	S	D	5.00	11.11
S13	Day	High	E	B	3.06	4.72
S14	Day	High	E	D	5.00	12.50
S15	Day	High	W	B	3.06	4.72
S16	Day	High	W	D	5.00	12.50
S17	Night	Low	N	F	calm	2.78
S18	Night	Low	S	F	0.83	2.78
S19	Night	Low	E	F	0.83	2.78
S20	Night	Low	W	F	0.83	2.78
S21	Night	High	N	E	3.06	4.72
S22	Night	High	S	E	3.06	4.72
S23	Night	High	E	E	3.06	4.72
S24	Night	High	W	E	3.06	4.72

5. POI Concentrations

Maximum POI concentrations were calculated for ten downwind distances (10 m, 35 m, 50 m, 90 m, 100 m, 110 m, 200 m, 300 m, 400 m, and 500 m) and evaluated for two release heights: one assuming no plume rise and one representing the largest plume rise scenario.

5.1 Emission Summary Table

The emissions summary compares the maximum expected POI concentrations to the MECP Ambient Air Quality Benchmarks (ACB) limits as an initial screening to identify contaminants that might be an exposure concern. Contaminants that exceeded ACB limits were further evaluated against Immediately Dangerous to Life or Health (IDLH) values, Ontario Occupational Exposure Limits (OOEL), and Acute Exposure Guideline Levels (AEGL). [9], [10], [11]. Contaminants without established short-term exposure limits were not assessed further.

As defined by the United States Environmental Protection Agency (EPA), AEGLs describe the human health effects from once-in-a-lifetime, or rare, exposure to airborne chemicals and are generally used by emergency responders when dealing with catastrophic exposures.

Exceeding IDLH would indicate an immediate danger to life or health if someone were exposed without protection. This assessment shows the IDLH levels are not reached, even under very conservative worst-case conditions.

Table A-1 and Table A-2 in Appendix A present results for worst-case operating conditions, including the highest emission rates and meteorological conditions likely to result in the greatest contaminant concentrations and compared against MECP POI Limits. Two release heights were assessed:

1. Battery container height (2.90 m), assuming no plume rise (Table A-1)
2. Effective stack height of 10.05 m, corresponding to a maximum plume rise of 7.16 m (Table A-2).

Results indicate that maximum POI concentrations generally occur at greater distances with higher plume rise since the plume travels further downwind before impingement at ground-level, resulting in lower maximum concentrations compared to the no plume rise case.

Contaminants exceeding the MECP POI limits were further evaluated against OOEL, AEGLs and IDLH criteria, as summarized in Table 5-1 and

Table 5-2. **Note:** these tables include only contaminants that exceeded MECP POI Limits. A complete list of maximum predicted concentrations and corresponding MECP POI limits is provided in Table A-1 and Table A-2 in Appendix A.

For AEGL comparisons, AEGL-1 values were used because they represent the most conservative thresholds; meeting AEGL-1 inherently ensures compliance with AEGL-2 and AEGL-3.

Table 5-1: Maximum Predicted Concentrations and Applicable Limits (No Plume Rise Scenario)

Contaminant	Scenario	Distance of Max Concentration (m)	Max Concentration (ug/m ³) (10-minute averaging)	Max Concentration (ug/m ³) (15-min averaging)	Max Concentration (ug/m ³) (8-hour averaging)	OOEL			IDLH			AEGL-1		
						PPM TWA (8-hour averaging)	ug/m ³ TWA (8-hour averaging)	% of OOEL Limit	PPM (15-min averaging)	ug/m ³ (15-min averaging)	% of IDLH Limit	PPM (10-minute averaging)	ug/m ³ (10-minute averaging)	% of AEGL-1
Ethylene	S3, S5, S7	10	4.34E+02	3.87E+02	1.47E+02	2.00E+02	2.29E+05	<1%	NA	NA	NA	NA	NA	NA
Dimethyl carbonate	S3, S5, S7	10	1.36E+04	1.22E+04	4.61E+03	NA	NA	NA	NA	NA	NA	NA	NA	NA
Benzene	S3, S5, S7	10	1.73E+02	1.54E+02	5.84E+01	5.00E-01	1.60E+03	4%	5.00E+02	1.60E+06	<1%	1.30E+02	4.15E+05	<1%
2,3,4-Trimethylpentane	S3, S5, S7	10	5.05E+02	4.50E+02	1.71E+02	NA	NA	NA	NA	NA	NA	NA	NA	NA
Cyclopentanone	S3, S5, S7	10	3.72E+02	3.32E+02	1.26E+02	NA	NA	NA	NA	NA	NA	NA	NA	NA
2-Octanol	S3, S5, S7	10	1.58E+03	1.41E+03	5.35E+02	NA	NA	NA	NA	NA	NA	NA	NA	NA
2-Ethylhexanol	S3, S5, S7	10	1.42E+04	1.27E+04	4.82E+03	NA	NA	NA	NA	NA	NA	NA	NA	NA
Naphthalene	S3, S5, S7	10	4.25E+02	3.79E+02	1.44E+02	1.00E+01	5.24E+04	<1%	2.50E+02	1.31E+06	<1%	NA	NA	NA
1-Nonanal	S3, S5, S7	10	6.28E+02	5.61E+02	2.13E+02	NA	NA	NA	NA	NA	NA	NA	NA	NA
Propylene tetramer	S3, S5, S7	10	9.29E+02	8.30E+02	3.14E+02	NA	NA	NA	NA	NA	NA	NA	NA	NA
1-Dodecanol	S3, S5, S7	10	1.44E+03	1.29E+03	4.87E+02	NA	NA	NA	NA	NA	NA	NA	NA	NA
2,2,4-trimethyl-1,3-pentanediol Diisobutyrate	S3, S5, S7	10	9.43E+04	8.41E+04	3.19E+04	NA	NA	NA	NA	NA	NA	NA	NA	NA
Methyl palmitate	S3, S5, S7	10	2.09E+03	1.87E+03	7.07E+02	NA	NA	NA	NA	NA	NA	NA	NA	NA
Methyl stearate	S3, S5, S7	10	9.89E+02	8.83E+02	3.35E+02	NA	NA	NA	NA	NA	NA	NA	NA	NA
Methacrolein	S3, S5, S7	10	1.55E+02	1.38E+02	5.24E+01	NA	NA	NA	NA	NA	NA	2.00E-01	5.73E+02	27%

Table 5-2: Maximum Predicted Concentrations and Applicable Limits (Plume Rise Scenario)

Contaminant	Scenario	Distance of Max Concentration (m)	Max Concentration (ug/m ³) (10-minute averaging)	Max Concentration (ug/m ³) (15-minute averaging)	Max Concentration (ug/m ³) (8-hour averaging)	OOEL			IDLH			AEGL-1		
						PPM TWA (8-hour averaging)	ug/m ³ TWA (8-hour averaging)	% of OOEL Limit	PPM (15-min averaging)	ug/m ³ (15-min averaging)	% of IDLH Limit	PPM (10-minute averaging)	ug/m ³ (10-minute averaging)	% of AEGL-1
Benzene	S18, S19, S20	100	1.44E+01	1.28E+01	4.87E+00	5.00E-01	1.60E+03	<1%	5.00E+02	1.60E+06	<1%	1.30E+02	4.15E+05	<1%
2-Ethylhexanol	S18, S19, S20	100	1.19E+03	1.06E+03	4.02E+02	NA	NA	NA	NA	NA	NA	NA	NA	NA
2,2,4-trimethyl-1,3-pentanediol Diisobutyrate	S18, S19, S20	100	7.86E+03	7.02E+03	2.66E+03	NA	NA	NA	NA	NA	NA	NA	NA	NA
Methyl stearate	S18, S19, S20	100	8.25E+01	7.36E+01	2.79E+01	NA	NA	NA	NA	NA	NA	NA	NA	NA
Methacrolein	S18, S19, S20	100	1.29E+01	1.15E+01	4.37E+00	NA	NA	NA	NA	NA	NA	2.00E-01	5.73E+02	2%

5.2 HF Results

HF results indicate that the highest concentrations occur at a distance of 10 m from the source, under a no plume rise scenario with a predicted 15-minute averaging concentration of $9.86 \times 10^3 \mu\text{g}/\text{m}^3$ (or $9.86 \text{ mg}/\text{m}^3$). This corresponds to approximately 40% of the IDLH limit of $2.45 \times 10^4 \mu\text{g}/\text{m}^3$. Refer to Table 5-3.

While the concentrations of HF exceeded the AEGL-1 threshold, they remain below the AEGL-2 threshold. Exceeding AEGL-1 suggests for noticeable but reversible irritation or discomfort according to the US EPA [12]; however, the concentration is not high enough to cause more serious disabling effects associated with AEGL-2 exceedances.

All calculated HF concentrations were below the IDLH limits.

5.2.1 No Plume Rise

For the no plume rise scenario, the three weather scenarios that produced the highest concentrations (S3, S5 and S7) were evaluated at a distance of 35 m to assess the dispersion further from the fire. HF levels at 35 m under the no plume rise scenario are reduced to approximately 81% of the AEGL-1 limit and less than 1% of the AEGL-2 limit. Results indicated that at 35 m from the source, as shown in Table 5-3, predicted concentrations do not indicate any immediate exposure risk under conservative modeling assumptions.

For the no plume rise scenario, it is reasonable to assume that concentrations beyond 35 m would continue to decrease due to further dispersion, resulting in even lower potential exposure risks.

5.2.2 Maximum Plume Rise

For the plume rise scenario, the three weather scenarios that produced the highest concentrations (S18, S19 and S20) were evaluated at a distance of 90 m and 110 m to assess the dispersion closer to and further from the fire. For the plume rise scenario, maximum HF concentrations occur at 100 m from the source and are 113% of the AEGL-1 threshold and less than 1% of the AEGL-2 threshold. Concentrations fall below all applicable short-term health-based benchmarks at a distance of 90 m and 110 m from the source.

For the plume rise scenario, it is reasonable to assume that concentrations before 90 m and beyond 110 m would continue to decrease due to further dispersion, resulting in even lower potential exposure risks.

Table 5-3: Maximum Predicted HF Concentrations and Applicable Limits

Contaminant	Plume Rise	Scenario	Distance of Max Concentration (m)	Max Concentration (µg/m³) (10 minute averaging)	Max Concentration (µg/m³) (15-min averaging)	Max Concentration (ug/m³) (8-hour averaging)	OOEL			IDLH			AEGL-1			AEGL-2		
							PPM TWA (8-hour averaging)	µg/m³ TWA (8-hour averaging)	% of OOEL Limit	PPM (15-min averaging)	µg/m³ (15-min averaging)	% of IDLH Limit	PPM (10-minute averaging)	µg/m³ (10-minute averaging)	% of AEGL-1	PPM (10-minute averaging)	µg/m³ (10-minute averaging)	% of AEGL-1
HF	No Plume Rise	S3,S5,S7	10	1.10E+04	9.86E+03	3.74E+03	5.00E-01	4.09E+02	914%	3.00E+01	2.45E+04	40%	1.00E+00	8.18E+02	1351%	95	77687	14%
HF	No Plume Rise	S3,S5,S7	35	6.59E+02	5.88E+02	2.23E+02	5.00E-01	4.09E+02	55%	3.00E+01	2.45E+04	2%	1.00E+00	8.18E+02	81%	95	77687	<1%
HF	Plume Rise	S18, S19, S20	90	2.83E+02	2.53E+02	9.57E+01	5.00E-01	4.09E+02	23%	3.00E+01	2.45E+04	1%	1.00E+00	8.18E+02	35%	95	77687	<1%
HF	Plume Rise	S18, S19, S20	100	9.21E+02	8.22E+02	3.12E+02	5.00E-01	4.09E+02	76%	3.00E+01	2.45E+04	3%	1.00E+00	8.18E+02	113%	95	77687	1.2%
HF	Plume Rise	S18, S19, S20	110	2.62E+02	2.34E+02	8.88E+01	5.00E-01	4.09E+02	22%	3.00E+01	2.45E+04	<1%	1.00E+00	8.18E+02	32%	95	77687	<1%

5.3 Assessment of Contaminants with no MECP POI Limits

Contaminants without established MECP POI limits were assessed using their *de minimis* concentrations to determine whether they could be considered insignificant. In accordance with the MECP *Procedure for Preparing an ESDM Report*, if measured concentrations were below $0.1 \mu\text{g}/\text{m}^3$ (24-hour average) or $0.3 \mu\text{g}/\text{m}^3$ (half-hour average), the contaminant was deemed insignificant. This is defined by the MECP as the *de minimis* concentration.

Seven contaminants without MECP POI limits were emitted at concentrations exceeding the *de minimis* thresholds, which classifies them as significant for this assessment. These contaminants include:

- Hydrogen
- Ethyl methyl carbonate
- 2,3,3-Trimethylpentane
- 4-Methyl-2-heptanol
- 2-Ethylhexyl formate
- 3,4-Dimethylcyclohexanol
- Eladic acid methyl ester.

De minimis thresholds are based on MECP POI limits, which are intended for comparison with ground level concentrations from releases during normal, ongoing facility operations. Applying these thresholds to a one-time emergency release event is therefore conservative. None of the contaminants assessed against *de minimis* thresholds had short-term exposure limits established under OOEL, IDLH or AEGL. Because *de minimis* thresholds are inherently conservative, they provide a protective basis for comparison; however no further short-term assessment was conducted given the absence of applicable exposure limits.

5.4 Averaging Times

The averaging times of modelling results are to be consistent with the averaging times of the ACB List. Concentrations for averaging times that are not available from the modeling are calculated using the conversion formula set out in s. 17 of Ontario Regulation 419/05 shown below:

$$C_0 = C_1 \times \left(\frac{t_1}{t_0}\right)^n$$

Where:

- C_0 is the concentration at the new averaging period
- C_1 is the concentration at the known averaging period
- t_0 is the new averaging period (10-Min, ½-Hour, 30-Day)
- t_1 is the known averaging period (usually 1-hr)
- n is 0.28

5.5 POI Comparison to Previous Assessment

Table 5-4 provides a comparison of the maximum predicted POI concentrations from the current weather scenario assessment against those reported in the previous ESDM report.

POI concentrations under the weather scenario assessment exceeded those reported in the previous ESDM assessment because the calculation methodology changed and now accounts for atmospheric stability and varying weather conditions. Atmospheric stability significantly influences weather dispersion.

- Stable conditions limit vertical mixing, causing pollutants to remain concentrated near the ground and close to the source.
- Unstable conditions enhance vertical mixing, dispersing pollutants over a larger area and reducing ground-level concentrations.

By incorporating varying weather conditions and stability classes, the current assessment reflects worst case scenarios.

Table 5-4: Comparison of Maximum POI Concentrations

Contaminant	Max Concentrations from Previous ESDM Report ($\mu\text{g}/\text{m}^3$) (1-hour averaging)	Max Concentration In Weather scenario Assessment - Low Stack ($\mu\text{g}/\text{m}^3$) (1-hour averaging)	Max Concentration In Weather Scenario Assessment - High Stack ($\mu\text{g}/\text{m}^3$) (1-hour averaging)
Hydrogen	2.45E+03	3.97E+03	3.31E+02
Methane	2.87E+03	4.65E+03	3.87E+02
Ethylene	1.62E+02	2.63E+02	2.19E+01
Methanol	6.75E+02	1.09E+03	9.11E+01
Ethanol	5.33E+02	8.63E+02	7.19E+01
Methyl acetate	1.53E+02	2.48E+02	2.07E+01
Ethyl acetate	1.53E+03	2.47E+03	2.06E+02

Brookfield Renewables - Owner's Engineer for South March BESS
Air Quality Assessment in Emergency Fire Scenario Under Variable Weather Scenarios - February 6, 2026

Contaminant	Max Concentrations from Previous ESDM Report ($\mu\text{g}/\text{m}^3$) (1-hour averaging)	Max Concentration In Weather scenario Assessment - Low Stack ($\mu\text{g}/\text{m}^3$) (1-hour averaging)	Max Concentration In Weather Scenario Assessment - High Stack ($\mu\text{g}/\text{m}^3$) (1-hour averaging)
Dimethyl carbonate	5.10E+03	8.25E+03	6.88E+02
Acetic acid	8.18E+02	1.33E+03	1.10E+02
Benzene	6.45E+01	1.04E+02	8.71E+00
DL-sec-Butyl acetate	1.44E+02	2.33E+02	1.94E+01
Ethyl methyl carbonate	5.37E+03	8.70E+03	7.26E+02
2,3,4-Trimethylpentane	1.89E+02	3.06E+02	2.55E+01
2,3,3-Trimethylpentane	2.83E+02	4.58E+02	3.82E+01
Toluene	1.90E+02	3.08E+02	2.57E+01
3-Methylheptane	2.36E+02	3.82E+02	3.18E+01
Cyclopentanone	1.39E+02	2.25E+02	1.88E+01
Diethyl carbonate	1.46E+02	2.37E+02	1.98E+01
2,2,4-Trimethylhexane	1.59E+02	2.57E+02	2.15E+01
1-Octene	9.27E+01	1.50E+02	1.25E+01
Octane	3.30E+02	5.35E+02	4.46E+01
Xylene	1.75E+02	2.84E+02	2.37E+01
2-Phenyl-1-propene	4.39E+01	7.11E+01	5.93E+00
4-Methyl-2-heptanol	5.38E+02	8.71E+02	7.26E+01
2-Octanol	5.92E+02	9.58E+02	7.99E+01
2-Ethylhexanol	5.32E+03	8.62E+03	7.19E+02
Benzoic acid	5.04E+01	8.17E+01	6.81E+00
2-Ethylhexyl formate	2.13E+02	3.46E+02	2.88E+01
Naphthalene	1.59E+02	2.57E+02	2.14E+01
3,4-Dimethylcyclohexanol	2.12E+02	3.43E+02	2.86E+01
Decane	2.94E+02	4.76E+02	3.97E+01
1-Decene	2.32E+02	3.75E+02	3.13E+01
1-Nonanal	2.35E+02	3.80E+02	3.17E+01
Propylene tetramer	3.48E+02	5.63E+02	4.69E+01
Trimethylene glycol monomethyl ether	1.86E+02	3.01E+02	2.51E+01
1-Dodecanol	5.39E+02	8.72E+02	7.27E+01
2,2,4-trimethyl-1,3-pentanediol Diisobutyrate	3.52E+04	5.71E+04	4.76E+03
Methyl palmitate	7.82E+02	1.27E+03	1.06E+02
Eladic acid methyl ester	1.59E+03	2.58E+03	2.15E+02
Methyl stearate	3.70E+02	5.99E+02	4.99E+01
Sulfur dioxide	5.29E+00	8.57E+00	7.14E-01
Hydrogen sulfide	2.81E+00	4.56E+00	3.80E-01
Nitrogen dioxide	9.50E+00	1.54E+01	1.28E+00
Formaldehyde	2.48E+01	4.02E+01	3.35E+00
Methacrolein	5.79E+01	9.37E+01	7.82E+00
Carbon Monoxide	2.89E+00	4.68E+00	3.90E-01
Hydrogen Fluoride	-	6.69E+03	5.58E+02

6. Conclusions

The preliminary assessment indicates that modeled concentrations of several contaminants exceeded provincial MECP POI limits under conservative assumptions. However, no IDLH thresholds were exceeded in any case. Key findings include:

- **No Plume Rise Scenario:**
 - ◆ Maximum ground level concentrations occurred at the closest distance (10 m) under daytime, low-wind conditions.
 - ◆ Sixteen contaminants, including HF, exceeded MECP POI Limits. Of these, only HF exceeded any short-term exposure benchmarks (OOEL, AEGL).
 - ◆ HF exceeded the AEGL-1 limit at 10 m from the source; however, it was within all short-term exposure limits at 35 m.
 - ◆ Seven contaminants assessed using *de minimis* thresholds exceeded the applicable MECP *de minimis* limits.
- **Maximum Plume Rise Scenario:**
 - ◆ Maximum ground level concentrations occurred further downwind (approximately 100 m from the source) due to increased plume rise (but at lower concentrations compared with max POI for the no plume rise case).
 - ◆ Six contaminants, including HF, exceeded the applicable MECP POI limits. Of these, only HF exceeded any short-term exposure benchmarks (AEGL).
 - ◆ HF concentrations exceeded the AEGL-1 at a distance of 100 m but were below the AEGL-1 at 90 m and 110 m from the source.
 - ◆ Seven contaminants assessed using *de minimis* thresholds exceeded the applicable MECP *de minimis* limits.

Results suggest that for the no plume rise scenario, short-term health-based benchmarks are not exceeded beyond very close distances (approximately 10 m). These concentrations decrease with distance and fall below applicable limits at 35 m from the source. For the maximum plume rise scenario at 100 m, one short-term health-based benchmark was exceeded (AEGL-1); however, concentrations remained below all other short-term health-based benchmarks at this distance. All concentrations presented here represent ground-level predictions. These findings are conservative and based on worst-case assumptions for emissions, meteorology, and plume behavior.

7. References

- [1] (DNV). *Sungrow Battery Energy Storage System (BESS) PowerTitan 2.0 – Large Scale Burn Test Report*. Document No.: 10522343-SHA-R-01, Issue D, Status: Final, Date: 21 February 2025.
- [2] Hatch Ltd. *LFP Battery Storage Safety Fire Simulation Results (Version 1)*. Date: 2025
- [3] Hatch Ltd. *Battery Energy Storage System (BESS) Thermal Runaway Event – Emission Summary and Dispersion Modeling Report, Marchurst Drive*. Date: 17 July 2025.
- [4] NOAA Air Resources Laboratory. *Briggs Plume Rise Equations*. Available at: https://www.ready.noaa.gov/documents/TutorialX/files/Rise_equations.pdf
- [5] U.S. EPA. *User's Guide for the Industrial Source Complex (ISC3) Dispersion Model*. EPA-454/B-03-001, U.S. Environmental Protection Agency, Research Triangle Park, NC.
- [6] Larsson, F., Andersson, P., Blomqvist, P., & Mellander, B.-E. *Toxic Fluoride Gas Emissions from Lithium-Ion Battery Fires*. Scientific Reports, Volume 7, Article 10018. Published: 30 August 2017. DOI: 10.1038/s41598-017-09784-z. Available at: <https://www.nature.com/articles/s41598-017-09784-z>
- [7] Environment and Climate Change Canada. *Historical Weather Data*. Available at: https://climate.weather.gc.ca/historical_data/search_historic_data_stations_e.html
- [8] Newport Corporation. *Introduction to Solar Radiation*. Available at: <https://www.newport.com/t/introduction-to-solar-radiation>
- [9] Centers for Disease Control and Prevention (CDC), National Institute for Occupational Safety and Health (NIOSH). *Immediately Dangerous to Life or Health (IDLH) Values*. Available at: <https://www.cdc.gov/niosh/idlh/default.html>
- [10] Government of Ontario. *Current Occupational Exposure Limits for Ontario Workplaces under Regulation 833*. Available at: <https://www.ontario.ca/page/current-occupational-exposure-limits-ontario-workplaces-under-regulation-833>
- [11] U.S. Environmental Protection Agency (EPA). *Compiled Acute Exposure Guideline Values (AEGVs): Update July 27, 2018*. Available at: https://www.epa.gov/sites/default/files/2018-08/documents/compiled_aegls_update_27jul2018.pdf
- [12] U.S. Environmental Protection Agency (EPA). *About Acute Exposure Guideline Levels (AEGVs)*. Available at: <https://www.epa.gov/aegl/about-acute-exposure-guideline-levels-aegls>

Appendix A Result Tables

Table A-1: Emission Summary of No Plume Rise Scenario

Contaminant	Scenario	Wind Direction	Max Concentration Distance (m)	Max Concentration (µg/m³)	Averaging Period	MECP POI Limit (µg/m³)	% of MECP POI Limit
Hydrogen	S3,S5,S7	S,E,W	10	3.97E+03	24 (DM)	DM (0.1<0.3)	DM
Methane	S3,S5,S7	S,E,W	10	4.65E+03	24-hour	37 330	5%
Ethylene	S3,S5,S7	S,E,W	10	2.63E+02	24-hour	40	270%
Methanol	S3,S5,S7	S,E,W	10	1.09E+03	24-hour	4 000	11%
Ethanol	S3,S5,S7	S,E,W	10	8.63E+02	1-hour	19 000	5%
Methyl acetate	S3,S5,S7	S,E,W	10	2.48E+02	24-hour	3 000	3%
Ethyl acetate	S3,S5,S7	S,E,W	10	2.47E+03	1-hour	19 000	13%
Dimethyl carbonate	S3,S5,S7	S,E,W	10	8.25E+03	24-hour	920	368%
Acetic acid	S3,S5,S7	S,E,W	10	1.33E+03	24-hour	2 500	22%
Benzene	S3,S5,S7	S,E,W	10	1.04E+02	Annual	0.45	1,827.5%
DL-sec-Butyl acetate	S3,S5,S7	S,E,W	10	2.33E+02	24-hour	4 750	2%
Ethyl methyl carbonate	S3,S5,S7	S,E,W	10	8.70E+03	24 (DM)	DM (0.1<0.3)	DM
2,3,4-Trimethylpentane	S3,S5,S7	S,E,W	10	3.06E+02	24-hour	100	125%
2,3,3-Trimethylpentane	S3,S5,S7	S,E,W	10	4.58E+02	24 (DM)	DM (0.1<0.3)	DM
Toluene	S3,S5,S7	S,E,W	10	3.08E+02	24-hour	2 000	6%
3-Methylheptane	S3,S5,S7	S,E,W	10	3.82E+02	24-hour	175	90%
Cyclopentanone	S3,S5,S7	S,E,W	10	2.25E+02	24-hour	85	109%
Diethyl carbonate	S3,S5,S7	S,E,W	10	2.37E+02	24-hour	120	81%
2,2,4-Trimethylhexane	S3,S5,S7	S,E,W	10	2.57E+02	24-hour	175	60%
1-Octene	S3,S5,S7	S,E,W	10	1.50E+02	24-hour	50 000	<1%
Octane	S3,S5,S7	S,E,W	10	5.35E+02	10-minute	61 800	<1%
Xylene	S3,S5,S7	S,E,W	10	2.84E+02	24-hour	7 300	2%
2-Phenyl-1-propene	S3,S5,S7	S,E,W	10	7.11E+01	1-hour	24 000	<1%
4-Methyl-2-heptanol	S3,S5,S7	S,E,W	10	8.71E+02	24 (DM)	DM (0.1<0.3)	DM
2-Octanol	S3,S5,S7	S,E,W	10	9.58E+02	24-hour	135	291%
2-Ethylhexanol	S3,S5,S7	S,E,W	10	8.62E+03	1-hour	600	1,437%
Benzoic acid	S3,S5,S7	S,E,W	10	8.17E+01	24-hour	700	5%
2-Ethylhexyl formate	S3,S5,S7	S,E,W	10	3.46E+02	24 (DM)	DM (0.1<0.3)	DM
Naphthalene	S3,S5,S7	S,E,W	10	2.57E+02	24-hour	22.5	469%
3,4-Dimethylcyclohexanol	S3,S5,S7	S,E,W	10	3.43E+02	24 (DM)	DM (0.1<0.3)	DM
Decane	S3,S5,S7	S,E,W	10	4.76E+02	1-hour	60 000	<1%
1-Decene	S3,S5,S7	S,E,W	10	3.75E+02	24-hour	60 000	<1%
1-Nonanal	S3,S5,S7	S,E,W	10	3.80E+02	24-hour	75	208%
Propylene tetramer	S3,S5,S7	S,E,W	10	5.63E+02	24-hour	22	1,051%
Trimethylene glycol monomethyl ether	S3,S5,S7	S,E,W	10	3.01E+02	24-hour	135	92%
1-Dodecanol	S3,S5,S7	S,E,W	10	8.72E+02	24-hour	75	478%
2,2,4-trimethyl-1,3-pentanediol Diisobutyrate	S3,S5,S7	S,E,W	10	5.71E+04	24-hour	420	5,581%
Methyl palmitate	S3,S5,S7	S,E,W	10	1.27E+03	24-hour	120	433%
Eladic acid methyl ester	S3,S5,S7	S,E,W	10	2.58E+03	24 (DM)	DM (0.1<0.3)	DM
Methyl stearate	S3,S5,S7	S,E,W	10	5.99E+02	24-hour	15	1,640%
Sulfur dioxide	S3,S5,S7	S,E,W	10	8.57E+00	1-hour	690	1%
Hydrogen sulfide	S3,S5,S7	S,E,W	10	4.56E+00	24-hour	70	3%
Nitrogen dioxide	S3,S5,S7	S,E,W	10	1.54E+01	24-hour	200	3%
Formaldehyde	S3,S5,S7	S,E,W	10	4.02E+01	24-hour	65	25%
Methacrolein	S3,S5,S7	S,E,W	10	9.37E+01	24-hour	1.2	3,208%
Carbon Monoxide	S3,S5,S7	S,E,W	10	4.68E+00	1/2-hour	6 000	<1%
HF	S3,S5,S7	S,E,W	10	6.69E+03	24-hour	0.86	319,467%

*DM = de minimis concentration as defined by the MECP.

Table A-2: Emission Summary Given Plume Rise Scenario

Contaminant	Scenario	Wind Direction	Max Concentration Distance (m)	Max Concentration In Weather Scenario Assessment	Averaging Period	MECP POI Limit (µg/m³)	% of MECP POI Limit
Hydrogen	S18,S19,S20	S,E,W	100	3.31E+02	24 (DM)	DM (0.1<0.3)	DM
Methane	S18,S19,S20	S,E,W	100	3.87E+02	24-hour	37 330	<1%
Ethylene	S18,S19,S20	S,E,W	100	2.19E+01	24-hour	40	22%
Methanol	S18,S19,S20	S,E,W	100	9.11E+01	24-hour	4 000	<1%
Ethanol	S18,S19,S20	S,E,W	100	7.19E+01	1-hour	19 000	<1%
Methyl acetate	S18,S19,S20	S,E,W	100	2.07E+01	24-hour	3 000	<1%
Ethyl acetate	S18,S19,S20	S,E,W	100	2.06E+02	1-hour	19 000	1%
Dimethyl carbonate	S18,S19,S20	S,E,W	100	6.88E+02	24-hour	920	31%
Acetic acid	S18,S19,S20	S,E,W	100	1.10E+02	24-hour	2 500	2%
Benzene	S18,S19,S20	S,E,W	100	8.71E+00	Annual	0.45	152.4%
DL-sec-Butyl acetate	S18,S19,S20	S,E,W	100	1.94E+01	24-hour	4 750	<1%
Ethyl methyl carbonate	S18,S19,S20	S,E,W	100	7.26E+02	24 (DM)	DM (0.1<0.3)	DM
2,3,4-Trimethylpentane	S18,S19,S20	S,E,W	100	2.55E+01	24-hour	100	10%
2,3,3-Trimethylpentane	S18,S19,S20	S,E,W	100	3.82E+01	24 (DM)	DM (0.1<0.3)	DM
Toluene	S18,S19,S20	S,E,W	100	2.57E+01	24-hour	2 000	<1%
3-Methylheptane	S18,S19,S20	S,E,W	100	3.18E+01	24-hour	175	7%
Cyclopentanone	S18,S19,S20	S,E,W	100	1.88E+01	24-hour	85	9%
Diethyl carbonate	S18,S19,S20	S,E,W	100	1.98E+01	24-hour	120	7%
2,2,4-Trimethylhexane	S18,S19,S20	S,E,W	100	2.15E+01	24-hour	175	5%
1-Octene	S18,S19,S20	S,E,W	100	1.25E+01	24-hour	50 000	<1%
Octane	S18,S19,S20	S,E,W	100	4.46E+01	10-minute	61 800	<1%
Xylene	S18,S19,S20	S,E,W	100	2.37E+01	24-hour	7 300	<1%
2-Phenyl-1-propene	S18,S19,S20	S,E,W	100	5.93E+00	1-hour	24 000	<1%
4-Methyl-2-heptanol	S18,S19,S20	S,E,W	100	7.26E+01	24 (DM)	DM (0.1<0.3)	DM
2-Octanol	S18,S19,S20	S,E,W	100	7.99E+01	24-hour	135	24%
2-Ethylhexanol	S18,S19,S20	S,E,W	100	7.19E+02	1-hour	600	120%
Benzoic acid	S18,S19,S20	S,E,W	100	6.81E+00	24-hour	700	<1%
2-Ethylhexyl formate	S18,S19,S20	S,E,W	100	2.88E+01	24 (DM)	DM (0.1<0.3)	DM
Naphthalene	S18,S19,S20	S,E,W	100	2.14E+01	24-hour	22.5	39%
3,4-Dimethylcyclohexanol	S18,S19,S20	S,E,W	100	2.86E+01	24 (DM)	DM (0.1<0.3)	DM
Decane	S18,S19,S20	S,E,W	100	3.97E+01	1-hour	60 000	<1%
1-Decene	S18,S19,S20	S,E,W	100	3.13E+01	24-hour	60 000	<1%
1-Nonanal	S18,S19,S20	S,E,W	100	3.17E+01	24-hour	75	17%
Propylene tetramer	S18,S19,S20	S,E,W	100	4.69E+01	24-hour	22	88%
Trimethylene glycol monomethyl ether	S18,S19,S20	S,E,W	100	2.51E+01	24-hour	135	8%
1-Dodecanol	S18,S19,S20	S,E,W	100	7.27E+01	24-hour	75	40%
2,2,4-trimethyl-1,3-pentanediol Diisobutyrate	S18,S19,S20	S,E,W	100	4.76E+03	24-hour	420	465%
Methyl palmitate	S18,S19,S20	S,E,W	100	1.06E+02	24-hour	120	36%
Eladic acid methyl ester	S18,S19,S20	S,E,W	100	2.15E+02	24 (DM)	DM (0.1<0.3)	DM
Methyl stearate	S18,S19,S20	S,E,W	100	4.99E+01	24-hour	15	137%
Sulfur dioxide	S18,S19,S20	S,E,W	100	7.14E-01	1-hour	690	<1%
Hydrogen sulfide	S18,S19,S20	S,E,W	100	3.80E-01	24-hour	70	<1%
Nitrogen dioxide	S18,S19,S20	S,E,W	100	1.28E+00	24-hour	200	<1%
Formaldehyde	S18,S19,S20	S,E,W	100	3.35E+00	24-hour	65	2%
Methacrolein	S18,S19,S20	S,E,W	100	7.82E+00	24-hour	1.2	267%
Carbon Monoxide	S18,S19,S20	S,E,W	100	3.90E-01	1/2-hour	6 000	<1%
HF	S18,S19,S20	S,E,W	100	5.58E+02	24-hour	0.86	26,635%

*DM = de minimis concentration as defined by the MECP.