

## Brookfield Renewables Owner's Engineer for South March BESS

### Air Quality Assessment in Emergency Fire Scenario Under Variable Weather Scenarios

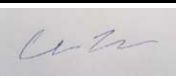

			<i>Karch, Julianna</i>		<i>Benoit, Clement</i>	-
2026-04-20	2	Approved for Use	J. Karch	C. Lyons	C. Benoit	
2026-02-11	1	Approved for Use	J. Karch	C. Lyons	C. Benoit	
2026-02-05	0	Approved for Use	J. Karch	C. Lyons	C. Benoit	-
<b>Date</b>	<b>Rev.</b>	<b>Status</b>	<b>Prepared By</b>	<b>Checked By</b>	<b>Approved By</b>	<b>Approved By</b>
<b>HATCH</b>						<b>Client</b>

## Important Notice to Reader

This report was prepared by Hatch Ltd. ("**Hatch**") for the sole and exclusive use of Brookfield BRP Canada Corp. (the "**Client**") for the purpose of analyzing the potential impacts to local air quality resulting from a thermal runaway of the proposed Battery Energy Storage System (BESS) for the South March BESS project, in Ottawa, Ontario. This report must not be used by the Client for any other purpose, or provided to, relied upon or used by any other person without Hatch's prior written consent.

This report contains the expression of the opinion of Hatch using its professional judgment and reasonable care based on information available and conditions existing at the time of preparation.

The use of, or reliance upon this report is subject to the following:

1. This report is to be read in the context of and subject to the terms of the relevant Project Addendum, P-079047, dated August 1, 2024, between Hatch and the Client (the "**Hatch Agreement**"), including any methodologies, procedures, techniques, assumptions and other relevant terms or conditions specified in the Hatch Agreement;
2. This report is meant to be read as a whole, and sections of the report must not be read or relied upon out of context;
3. This report has been prepared solely for informational purposes. It does not constitute a regulatory submission and should not be interpreted as such, and
4. Unless expressly stated otherwise in this report, Hatch has not verified the accuracy, completeness or validity of any information provided to Hatch by or on behalf of the Client and Hatch does not accept any liability in connection with such information. The inclusion of referenced materials or findings from other studies does not imply certification, endorsement, or professional validation.
5. Given the complexity of a runaway fire event at a BESS and due to a lack of widely available published data and information on air contaminant releases, the methodology applied to estimate air contaminant release rates used in the plume modelling is not standard and is based on several assumptions. As such, there is uncertainty in the release estimates applied in the study.

## Addendum

The following updates have been made since issuance of the February 11, 2026, report:

1. **Updated Averaging Period Assumptions**

Release concentrations have been increased to reflect updated averaging period assumptions. As a result, the modeled maximum concentrations for all contaminants have increased relative to those presented in the original report. These updated assumptions will also be reflected in the initial reports completed in 2025.

2. **Comparison to Health-Based Thresholds**

Despite the increase in modeled concentrations, all contaminants remain below applicable Immediately Dangerous to Life or Health (IDLH) and Acute Exposure Guideline Level (AEGL) thresholds.

3. **Revised Hydrogen Fluoride (HF) Release Concentration**

The HF release concentration is no longer based on the literature value referenced in the original report (50 ppm). Instead, the HF release concentration has been updated based on the DNV letter indicating that no HF was detected in the samples.

The release concentration for HF has therefore been set equal to the Limit of Detection (LOD) for ion chromatography, 0.011 ppm, as reported in NMAM 7906: Particulate Fluorides and Hydrofluoric Acid by Ion Chromatography.

4. **Updated Conclusions Regarding HF Concentrations with Distance**

Based on the updated HF release concentration, the previous statement indicating that HF concentrations fall below all IDLH and AEGL thresholds beyond 110 m has been revised. Under the updated assumptions, modeled contaminants, including HF, are below the applicable IDLH and AEGL thresholds at 50 m from the source.

The updates described in this Addendum supersede the corresponding assumptions and statements in the February 11, 2026, report where applicable. All other methods, inputs, and conclusions presented in the original report remain unchanged.

**Table of Contents**

**1. Project Description..... 1**

**2. Introduction..... 2**

    2.1 Purpose and Scope ..... 2

    2.2 Property and Surrounding Area Description ..... 3

    2.3 Project Description ..... 4

    2.4 Reference Reports ..... 5

        2.4.1 Sungrow Fire Study ..... 5

        2.4.2 Fire Modeling Exercise ..... 5

        2.4.3 Emission Summary and Dispersion Modeling Report ..... 5

**3. Emergency Scenario, Emission Rate Estimation and Data Quality ..... 6**

    3.1 Description of Emergency Scenario ..... 6

    3.2 POI Calculation Methods ..... 6

        3.2.1 Emission Rates ..... 7

        3.2.2 Effective Stack Height ..... 8

        3.2.3 Dispersion Coefficients ..... 10

        3.2.4 POI Calculations ..... 10

**4. Local Meteorological Conditions ..... 10**

    4.1 Weather Conditions ..... 10

        4.1.1 Weather Scenarios ..... 11

**5. POI Concentrations ..... 12**

    5.1 Emission Summary Table ..... 13

    5.2 Results ..... 15

    5.3 Assessment of Contaminants with no MECP POI Limits ..... 15

    5.4 Averaging Times ..... 16

    5.5 POI Comparison to Previous Assessment ..... 16

**6. Conclusions ..... 18**

**7. References ..... 19**

**List of Figures**

Figure 2-1: Battery Energy Storage System Geometry ..... 3

Figure 2-2: Site Plan Layout ..... 4

Figure 3-1: Gaussian Plume Distribution ..... 7

Figure 3-2: Gaussian Pollutant Concentration and Dispersion Profiles ..... 9

### ***List of Tables***

Table 3-1: Dispersion Coefficient Equations .....	10
Table 4-1: Stability Class Descriptions .....	11
Table 4-2: Meteorological Conditions Influencing Pasquils Stability Classes.....	11
Table 4-3: Evaluated Scenarios with Minimum and Maximum Wind Speeds .....	12
Table 5-1: Maximum Predicted Concentrations and Applicable Limits (No Plume Rise Scenario).....	14
Table 5-2: Maximum Predicted Concentrations and Applicable Limits (Plume Rise Scenario) .....	14
Table 5-4: Comparison of Maximum POI Concentrations .....	16

### ***List of Appendices***

**Appendix A Result Tables**

**Appendix B DNV Clarification Letter**

## **1. Project Description**

Fitzroy BESS Inc., a subsidiary of Evolgen by Brookfield Renewable (Brookfield) in partnership with the Algonquins of Pikwàkanagàn and is proposing to develop the South March Battery Energy Storage System (BESS) Project (the Project). The Project will be in the West Carleton-March Ward in the City of Ottawa, Ontario. The Project is located on two leased parcels of land at 2555 and 2625 Marchurst Road, Ottawa, Ontario, and situated south of Thomas A. Dolan Parkway, west of Marchurst Road, and north of John Aselford Drive. The Project has a Development Area of approximately 9.0 hectares on approximately 84.5 hectares of property. The leased rural lots currently include two residential buildings with an access lane, naturalized areas with woodland and wetland, as well as limited non-commercial pasture use.

The Project is a 250-megawatt (MW) energy storage facility that uses lithium ion (lithium iron phosphate) technology and is designed to store up to 1,000 megawatt hours of energy, providing four hours of continuous discharge at full capacity.

The Project will consist of 256 BESS containers at the start of commercial operations and will progressively increase to 307 BESS containers over the duration of the IESO Offtake Agreement. The additional BESS containers will be added through the augmentation process to maintain the required 250 MW capacity. This process is further detailed within the Augmentation Process Memo.

This report considers the full Augmentation Process (a total of 307 BESS containers). Its findings and conclusions are not affected by any stage of augmentation, from 256 to 307 BESS containers.

## **2. Introduction**

Hatch was retained by Brookfield Renewables to conduct an analysis of potential impacts to local air quality resulting from a thermal runaway of the proposed Battery Energy Storage System (BESS) for the South March project. Brookfield is proposing to develop a site located at 2555 Marchurst Road and 2625 Marchurst Road in Dunrobin, Ontario, west of Ottawa (the "Site"). The proposed development involves the construction of 256 BESS containers, 64 medium voltage transformers, a substation, access roads and associated electrical infrastructure (the "Project"). Over the project life, additional BESS containers and medium voltage transformers will be added for a planned total of 307 BESS container and 77 medium voltage transformers. The Project is being implemented in response to the Independent Electricity System Operator's (IESO) Long Term 1 (LT1) call for capacity in 2024. The BESS will support the IESO to meet Ontario's growing electricity demand by constructing an energy storage facility. The facility will increase renewable grid capacity and storage, enhance flexible grid operations and provide a low carbon initiative to lower greenhouse gas emissions by reducing reliance on higher carbon intensive power generation.

### **2.1 Purpose and Scope**

This report builds upon Hatch's previous assessment, "*Battery Energy Storage System (BESS) Thermal Runaway Event Emission Summary and Dispersion Modeling Report*," by evaluating the influence of local weather patterns on contaminant dispersion. The earlier assessment determined the potential impacts on local air quality resulting from a thermal runaway event at the BESS facility. In this follow-up analysis, the focus is on how worst-case weather conditions could affect contaminant concentrations, with the objective of characterizing potential public and occupational exposure.

The scope of this assessment considers air contaminant releases from a single battery container comprising 48 lithium-ion battery modules, arranged in four modules per rack, as shown in Figure 2-1. Emission estimates for a thermal runaway event are based on the specific chemical composition of the batteries, including electrolyte, cathode, and anode materials. For this analysis, a worst-case scenario is defined as the ignition of all top modules within the container. During such an event, exothermic reactions occur within the battery components, releasing gases such as carbon monoxide (CO), Hydrogen (H<sub>2</sub>), various volatile organic compounds (VOCs), Hydrogen Fluoride (HF) and Polycyclic Aromatic Hydrocarbons (PAHs).

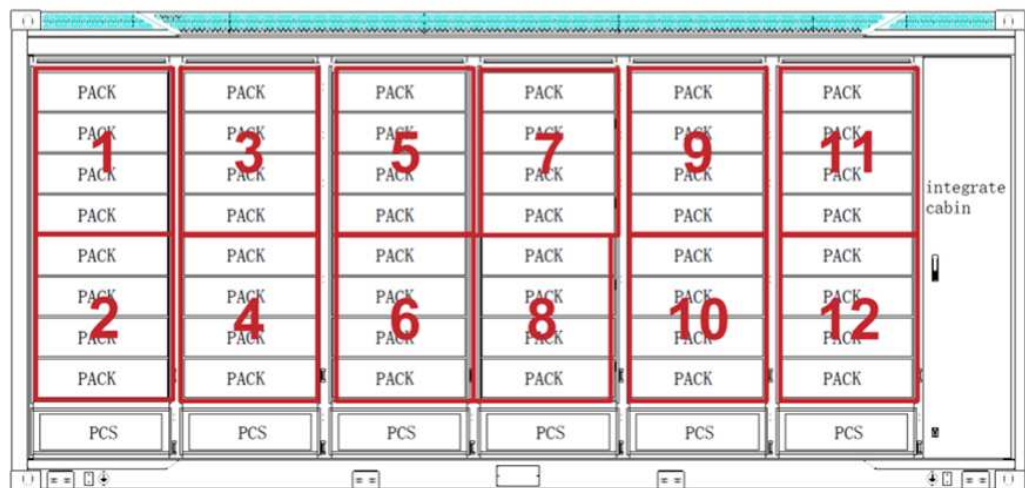

**Figure 2-1: Battery Energy Storage System Geometry**

## 2.2 Property and Surrounding Area Description

The Project site is a ~100-acre area located approximately 3.5 kilometers south-southwest of the community of Dunrobin outside of Ottawa. The proposed Project includes development of the Site with a substation, access roads and associated electrical infrastructure. Refer to Figure 2-2 for the Site layout.

The Site is located in an area that is currently zoned as Rural Countryside and includes, according to the City of Ottawa Zoning By-Law 2026-50. The areas surrounding the Site are zoned as Rural Countryside, Environmental Protection and Agricultural areas. Based on a google imagery, the nearest sensitive receptor is located over 100 m from the project's fenceline.

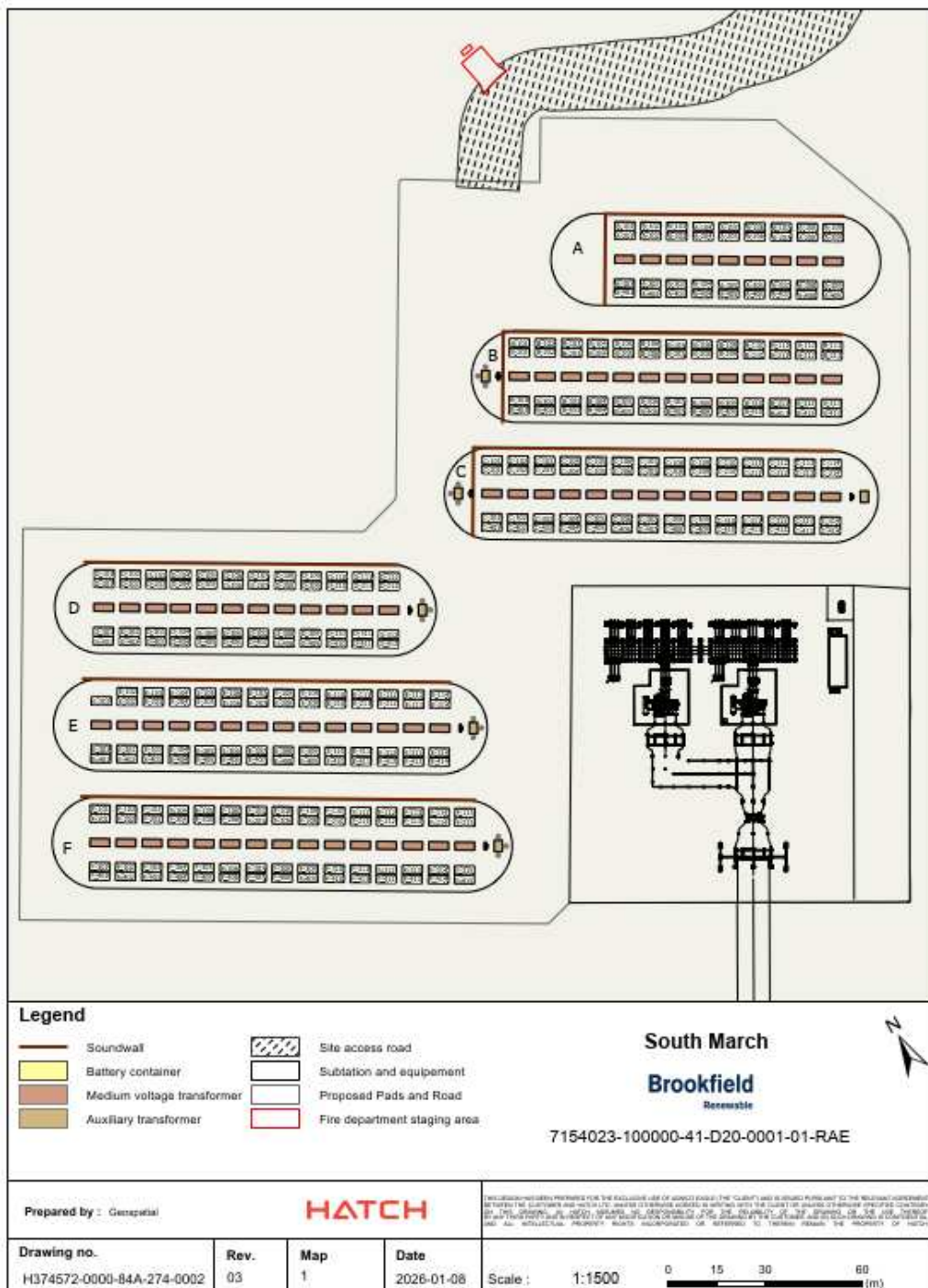

Figure 2-2: Site Plan Layout

## 2.3 Project Description

This assessment evaluates potential air quality impacts from a thermal runaway event at a Battery Energy Storage System (BESS) facility. The focus is on estimating Point of Impingement (POI) concentrations for key contaminants under worst-case conditions.

Unlike previous studies that included plume dispersion modeling, this assessment uses a calculation-based approach applying the Gaussian Plume Equation to determine POI concentrations at specified distances and release heights.

## **2.4 Reference Reports**

### **2.4.1 *Sungrow Fire Study***

Sungrow Power Supply Co., Ltd. engaged Det Norske Veritas (DNV) to develop a Large Scale Burn Test plan for their PowerTitan 2.0 Full-Size Container BESS system in the Sungrow Fire Study (SFD) report [1]. The test aimed to assess the impact of an extreme battery failure scenario, where multiple cells simultaneously experience thermal runaway, leading to propagation through the module stack and resulting in a significant battery container fire.

The goal of the large-scale burn test was to simulate an extreme battery failure event and evaluate the impact of a fully developed fire within the unit that could be caused by either internal or external factors. The extreme scenario assumed that the majority of cells within a module are triggered into thermal runaway, ensuring a large-scale battery fire ensues.

The results of this report assessed the spread of the event, the temperature of the containers during the fire, the heat flux within the study and the resulting concentrations of a suite of 45 gases downwind of the event (10 m distance and 1 m high).

### **2.4.2 *Fire Modeling Exercise***

The Fire Modeling Exercise (FME) prepared by Hatch Ltd. modeled a thermal runaway event occurring in one single battery container [2]. This study was completed to assess the safety of a lithium battery storage facility by identifying potential contaminants, conducting an emission inventory, and performing fire dynamics modeling to evaluate fire-related hazards, airborne emissions, and their potential impact on the surrounding environment and human health.

The fire modeling software, PyroSim was used for the air emissions modeling of the FME. The emissions of contaminants were assessed using a worst-case scenario. Boundary conditions were defined to simulate an open environment, allowing the unrestricted flow of gases and heat at the top and sides of the fire, while the bottom boundaries were treated as walls. The results of this exercise provided the heat release rate, the maximum temperature and varying contaminant concentrations. The maximum concentration results of CO from the fire simulator were used in this assessment as the maximum POI concentrations with a 1-hour averaging period for the most conservative results.

The modeling process involved simulating these reactions and the subsequent emissions to predict the dispersion patterns and concentrations of these hazardous substances.

### **2.4.3 *Emission Summary and Dispersion Modeling Report***

The latest assessment conducted by Hatch Ltd. followed the structure of an Emission Summary and Dispersion Modeling (ESDM) report to present a screening-level prediction of the max concentrations [3]. This analysis incorporated data from two previously referenced studies, the Sungrow fire study and the fire modeling exercise to estimate maximum POI concentrations under worst-case conditions.

### 3. Emergency Scenario, Emission Rate Estimation and Data Quality

This section provides a description of the emergency scenario used to assess the potential worst-case emissions during a thermal runaway event. The section also outlines the emission estimation methods used.

#### 3.1 Description of Emergency Scenario

For this assessment, a worst-case emergency scenario was defined to represent conditions that could result in the highest emission rates of contaminants of potential concern. This scenario assumes a thermal runaway event within a battery container, leading to propagation through multiple modules and a fully developed fire. Adverse meteorological conditions were also considered to capture the greatest potential off-site impacts.

The scenario integrates findings from three key sources:

- **Sungrow Fire Study (SFD):** Provided large-scale burn test data, including heat flux, container temperatures, and concentrations of 45 contaminants measured downwind of the event [1].
- **Fire Modeling Exercise (FME):** Used PyroSim to simulate fire dynamics, heat release rates, and contaminant dispersion under worst-case conditions [2].
- **ESDM Assessment:** Applied concentrations to evaluate compliance with MECP POI limits [3].

Maximum contaminant concentrations for this assessment were derived from the ESDM report, informed by both the Sungrow test results and PyroSim modeling outputs.

#### 3.2 POI Calculation Methods

The dispersion of contaminants was assessed using the Gaussian Plume equation, which is the basis for regulatory plume models, such as AERMOD. This approach is based on the assumption that pollutant concentration across the plume's cross-section follows a Gaussian (normal) distribution. In other words, it is assumed that the highest concentration occurs along the plume centerline, and concentrations decrease symmetrically away from the center in both the crosswind and vertical directions (Refer to Figure 3-1 for a schematic), i.e., following a normal distribution. The concentrations calculated from the Gaussian equation represent ground-level predictions. This model accounts for emission rate, wind speed, atmospheric dispersion, and effective source height to predict concentrations at various ground-level distances downwind.

The Gaussian Plume equation used in this assessment is presented below.:

$$C(x, y = 0, z = 0) = \frac{Q}{2\pi u \sigma_y \sigma_z} \cdot \exp\left(-\frac{H^2}{2\sigma_z^2}\right)$$

Where:

- $C(x, y = 0, z = 0)$  = concentration at ground level ( $\mu\text{g}/\text{m}^3$ ) at distance  $x$  downwind, and assuming concentration at the centerline of the plume ( $y=0$ )
- $Q$  = emission rate ( $\mu\text{g}/\text{s}$ )
- $u$  = wind speed (m/s)
- $\sigma_y, \sigma_z$  = crosswind and vertical dispersion coefficients (m)
- $H$  = effective release height (m), defined as the physical release height plus the plume rise resulting from buoyancy and momentum of the exhaust gases.
- $x$  = downwind distance from the source (m)

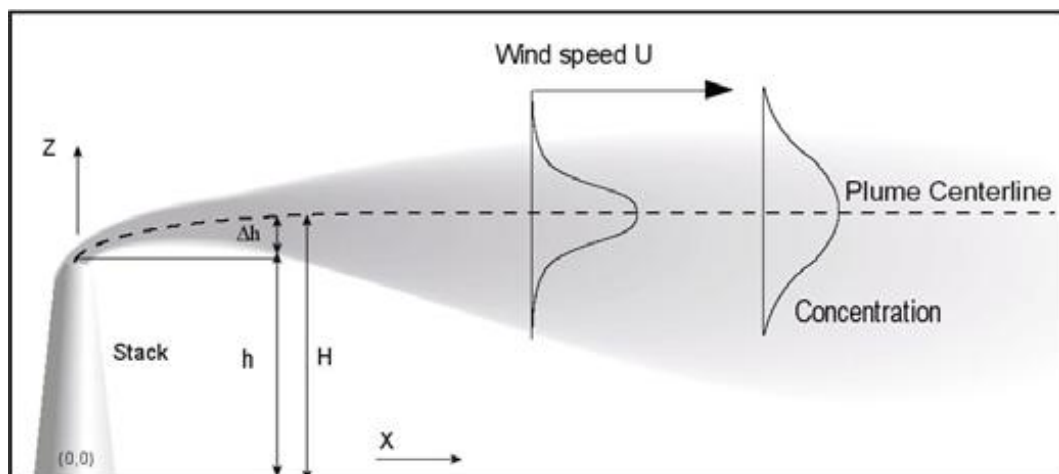

Figure 3-1: Gaussian Plume Distribution

### 3.2.1 Emission Rates

Emission rates for each contaminant were back calculated using the Gaussian Plume Equation by isolating for  $Q$  (emission rate in g/s). Modeled ground-level concentrations from the previous ESDM assessment (based on measured concentrations from the Sungrow Fire Study) served as the basis for these calculations. This approach was used to estimate air contaminant release rates as there is a lack of widely available published data and information on air contaminant releases from a runway fire event at a BESS, e.g., such as published emission factors or other typical estimation approaches. Thus, the methodology applied for the estimated air contaminant release rates used in the plume modelling is not standard and based on several assumptions. As such, there is uncertainty in the release estimates applied in the study.

To calculate emission rates, the following assumptions were applied:

- **Wind Speed:** An average of 1.35 m/s, based on measurements from the Sungrow Fire Study, representing conditions during the testing period (measured winds ranged from 0–2.7 m/s).
- **Atmospheric Stability Class:** Stability Class B (moderately unstable conditions) was applied to reflect the actual atmospheric conditions during the Sungrow Fire Study (daytime conditions with average wind speeds of 1.35m/s). Refer to Table 4-1 for a full list of Stability Class descriptions.
- **Effective Stack Height:** The effective release height was assumed to be equal to the battery container height (2.9 m), representing the lowest feasible release height during the fire. Lower release heights produce higher ground-level concentrations because the plume has less vertical distance to rise, disperse and dilute before reaching receptors.

These parameters were applied to calculate emission rates for each contaminant.

### 3.2.2 **Effective Stack Height**

For scenarios assessed using plume rise, the effective stack height was calculated using the Briggs Buoyancy Plume Rise Equation at standard temperature and pressure [4].

The first step was to compute the Buoyant Heat Flux (F) [4]:

$$F = \frac{gQ_h}{\rho C_p T_a}$$

Where:

- F = Buoyancy Flux Parameter (m<sup>4</sup>/s<sup>3</sup>)
- Q<sub>h</sub> = Heat release rate of fire (J/s)
- g = gravitational acceleration (9.81 m/s<sup>2</sup>)
- ρ = Density of air (kg/m<sup>3</sup>)
- C<sub>p</sub> = Specific heat capacity of air (J/Kg)
- T<sub>a</sub> = Ambient Temperature (K)

The heat release rate was calculated using the heat flux of the fire (130 kW/m<sup>2</sup>) obtained from the PyroSim study. The area of the fire was assumed to be top layer of battery modules within the container (14.4 m<sup>2</sup>), resulting in a total heat release rate of 1872000 J/s (W) or 1.872 MW.

$$Q_h = \text{Heat Flux} \left( \frac{\text{kw}}{\text{m}^2} \right) * \text{Area of the Fire (m}^2\text{)}$$

The plume rise ( $\Delta h$ ) was then calculated using the Briggs equation. A low wind speed of 1.35 m/s, representing conditions during the Sungrow Fire study was used in this calculation:

$$\Delta h = 2.6 \frac{F^{1/3}}{u}$$

Where:

- $\Delta h$  = plume rise (m)
- $F$  = Heat release rate of fire (J/s)
- $u$  = wind speed

The effective stack height was calculated by adding the plume rise ( $\Delta h$ ) to the battery container height (2.90 m). Refer to Figure 3-2 for a schematic.

$$h_{eff} = \Delta h + \text{Height of Container}$$

Under these conditions the maximum plume rise was calculated to be approximately 10 m above the source.

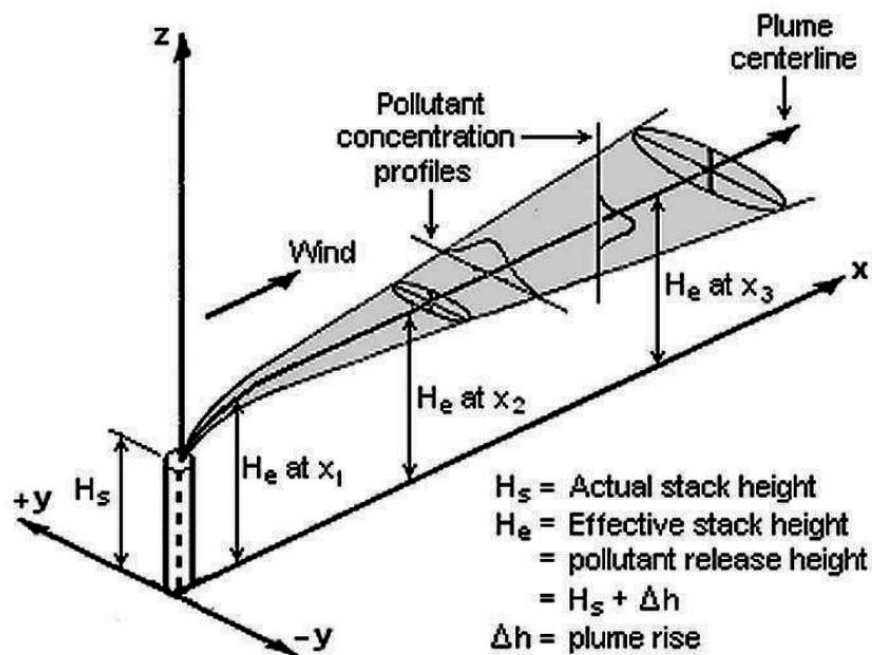

Figure 3-2: Gaussian Pollutant Concentration and Dispersion Profiles

### 3.2.2.1 Temperatures Effect on Plume Rise

In a fire scenario, ambient temperature has very little effect on plume rise. From the Pyrosim model report, the peak fire temperature reaches 620 °C, while the lowest ambient temperature from the 2024 dataset was -19.3 °C. Because the fire plume temperature is so much higher than the ambient temperature, even large (relative)

changes in ambient temperature will have a negligible effect on the temperature difference that drives buoyancy.

In fire scenarios, the buoyancy flux is controlled primarily by the heat release rate ( $Q_h$ ) and the resulting high plume temperatures of the fire.

**3.2.3 Dispersion Coefficients**

Dispersion coefficients ( $\sigma_y$  and  $\sigma_z$ ) for varying downwind distances were calculated using formulas from the EPA Industrial Source Complex (ISC3) User Guide [5] and summarized in Table 3-1. These coefficients represent the standard deviations (i.e. a measure of how widely concentrations vary around the centreline of the plume):  $\sigma_y$  describes the spread in the crosswind directions, and  $\sigma_z$  in the vertical directions, indicating how the plume spreads laterally and vertically as it moves downwind. The formulas are based on Pasquill Stability Categories. Refer to Table 4-1 for a full list of Stability Class descriptions (Stability Classes A-F).

**Table 3-1: Dispersion Coefficient Equations**

Pasquill Stability Category	$\sigma_y$	$\sigma_z$
A	$0.32x (1 + 0.0004 x)^{-1/2}$	$0.24x (1 + 0.001 x)^{1/2}$
B	$0.32x (1 + 0.0004 x)^{-1/2}$	$0.24x (1 + 0.001 x)^{1/2}$
C	$0.22x (1 + 0.0004 x)^{-1/2}$	0.20x
D	$0.16x (1 + 0.0004 x)^{-1/2}$	$0.14x (1 + 0.0003 x)^{-1/2}$
E	$0.11x (1 + 0.0004 x)^{-1/2}$	$0.08x (1 + 0.0015 x)^{-1/2}$
F	$0.11x (1 + 0.0004 x)^{-1/2}$	$0.08x (1 + 0.0015 x)^{-1/2}$

\*x = downwind distance from the source (in meters)

\* $\sigma_y, \sigma_z$  in meters

**3.2.4 POI Calculations**

A total of 24 scenarios were assessed to capture all combinations of time of day, wind speed, wind direction, and atmospheric stability class. POI concentrations for each of the 24 scenarios were calculated using the Gaussian Plume Model, based on the emission rates and meteorological conditions defined in this assessment.

Each scenario evaluated 47 contaminants emitted from the thermal runaway event. Carbon Monoxide concentrations were calculated based on data from the Pyrosim model report and HF concentrations were calculated based on a letter from DNV indicating that there was no HF detected in the samples from the Sungrow Fire Study (Appendix B). Accordingly, HF release concentrations were conservatively set to the ion chromatography limit of detection (0.011 ppm), as reported in NIOSH NMAM Method 7906 [6].

**4. Local Meteorological Conditions**

**4.1 Weather Conditions**

Hourly weather data for 2024 were obtained from the Environment and Climate Change Canada (ECCC) Historical Data database [7]. Data measured at the Ottawa International Airport surface station (Climate ID: 6106001) were retrieved. This is the closest available station in the ECCC database to the Project site, located approximately 30 km away. The

dataset was used to characterize specific meteorological conditions for the assessment.

### 4.1.1 Weather Scenarios

Pasquill-Gifford (PG) stability classes were used to characterize the atmospheric stability for each hour of weather data throughout 2024. Atmospheric stability refers to the tendency of the atmosphere to resist or enhance vertical motion, which directly affects how pollutants disperse. Unstable conditions promote strong mixing and rapid dispersion, while stable conditions suppress mixing, causing pollutants to tend to remain concentrated near the surface. These classes, summarized in Table 4-1, range from extremely unstable to extremely stable conditions.

**Table 4-1: Stability Class Descriptions**

Stability Classes	Stability Description
A	Extremely unstable conditions
B	Moderately unstable conditions
C	Slightly unstable conditions
D	Neutral conditions
E	Slightly stable conditions
F	Moderately stable conditions
G	Extremely Stable

The classification for each hour was determined based on three primary factors: wind speed, cloud cover (which influences the amount of solar radiation reaching the surface), and time of day (daytime vs. nighttime). Stability mainly depends on surface heating and wind speeds:

- Daytime conditions with strong solar radiation (clear skies) promote surface heating and thermal convection, resulting in unstable conditions (increased convective mixing in the atmosphere). (Note: Solar radiation at the earth's surface is highest around midday during the summer season, reaching approximately 1000 W/m<sup>2</sup> [8] under clear skies, which enhances convection compared to winter months).
- Nighttime conditions with clear skies lead to radiative cooling of the surface, reducing turbulence and creating stable conditions (limited vertical mixing).
- Wind speed also plays a critical role: higher wind speeds enhance turbulence, which tends to reduce stability and shift conditions toward unstable (increased mechanical mixing). Conversely, calm winds favor stable conditions.

This classification approach (Table 4-2) was applied to each hour of weather data for the entire year of 2024.

**Table 4-2: Meteorological Conditions Influencing Pasquils Stability Classes**

Surface Wind Speed (m/s)	Daytime Insolation			Night-time Conditions	
	Strong (Clear, Sunny)	Moderate (Partly Cloudy)	Slight (Very Cloudy)	Thin Overcast/ Low Cloud	Cloudy
<2	A	B	B	E	F
2 to 3	B	B	C	E	F
3 to 5	B	C	C	D	E
5 to 6	C	D	D	D	D
> 6	C	D	D	D	D

A total of 24 scenarios were assessed to capture all combinations of time of day, wind speed, wind direction, and atmospheric stability class. Using hourly meteorological data, the maximum and minimum wind speeds for each scenario were identified to evaluate worst-case concentrations under both low-wind and high-wind conditions (Table 4-3).

For this assessment, wind speeds below 3 m/s were classified as low-wind conditions, while those equal to or greater than 3 m/s were classified as high-wind conditions. In scenarios where the minimum wind speed was 0 m/s, the Gaussian dispersion model was not applied because the model assumes continuous plume transport, which is not valid under calm conditions.

**Table 4-3: Evaluated Scenarios with Minimum and Maximum Wind Speeds**

Scenario	Day/Night	Wind (High/Low)	Wind Direction	Stability Class	Min Wind Speed (m/s)	Max Wind Speed (m/s)
S1	Day	Low	N	B	calm	2.78
S2	Day	Low	N	C	2.22	2.78
S3	Day	Low	S	B	0.83	2.78
S4	Day	Low	S	C	2.22	2.78
S5	Day	Low	E	B	0.83	2.78
S6	Day	Low	E	C	2.22	2.78
S7	Day	Low	W	B	0.83	2.78
S8	Day	Low	W	C	2.22	2.78
S9	Day	High	N	B	3.06	4.72
S10	Day	High	N	D	5.00	10.00
S11	Day	High	S	B	3.06	4.72
S12	Day	High	S	D	5.00	11.11
S13	Day	High	E	B	3.06	4.72
S14	Day	High	E	D	5.00	12.50
S15	Day	High	W	B	3.06	4.72
S16	Day	High	W	D	5.00	12.50
S17	Night	Low	N	F	calm	2.78
S18	Night	Low	S	F	0.83	2.78
S19	Night	Low	E	F	0.83	2.78
S20	Night	Low	W	F	0.83	2.78
S21	Night	High	N	E	3.06	4.72
S22	Night	High	S	E	3.06	4.72
S23	Night	High	E	E	3.06	4.72
S24	Night	High	W	E	3.06	4.72

## 5. POI Concentrations

Maximum POI concentrations were calculated for seven downwind distances (10 m, 50 m, 100 m, 200 m, 300 m, 400 m, and 500 m) and evaluated for two release heights: one assuming no plume rise and one representing the largest plume rise scenario.

## 5.1 Emission Summary Table

The emissions summary compares the maximum expected POI concentrations to the MECP Ambient Air Quality Benchmarks (ACB) limits as an initial screening to identify contaminants that might be an exposure concern. Contaminants that exceeded ACB limits were further evaluated against Immediately Dangerous to Life or Health (IDLH) values, and Acute Exposure Guideline Levels (AEGL). [9], [10]. Contaminants without established short-term exposure limits were not assessed further.

As defined by the United States Environmental Protection Agency (EPA), AEGLs describe the human health effects from once-in-a-lifetime, or rare, exposure to airborne chemicals and are generally used by emergency responders when dealing with catastrophic exposures.

Exceeding IDLH would indicate an immediate danger to life or health if someone were exposed without protection. This assessment shows the IDLH levels are not reached, even under very conservative worst-case conditions.

Table A-1 and Table A-2 in Appendix A present results for worst-case operating conditions, including the highest emission rates and meteorological conditions likely to result in the greatest contaminant concentrations and compared against MECP POI Limits. Two release heights were assessed:

1. Battery container height (2.90 m), assuming no plume rise (Table A-1).
2. Effective stack height of 10.05 m, corresponding to a maximum plume rise of 7.16 m (Table A-2Table A-2).

Results indicate that maximum POI concentrations generally occur at greater distances with higher plume rise since the plume travels further downwind before impingement at ground-level, resulting in lower maximum concentrations compared to the no plume rise case.

Contaminants exceeding the MECP POI limits were further evaluated against AEGLs and IDLH criteria, as summarized in Table 5-1 and Table 5-2. **Note:** these tables include only contaminants that exceeded MECP POI Limits with corresponding short term exposure limits. A complete list of maximum predicted concentrations and corresponding MECP POI limits is provided in Table A-1 and Table A-2Table A-2 in Appendix A.

For AEGL comparisons, AEGL-1 values were used because they represent the most conservative thresholds; meeting AEGL-1 inherently ensures compliance with AEGL-2 and AEGL-3.

**Table 5-1: Maximum Predicted Concentrations and Applicable Limits (No Plume Rise Scenario)**

Contaminant	Scenario	Distance of Max Concentration (m)	Max Concentration (ug/m3) (10-minute averaging)	Max Concentration (ug/m3) (15-min averaging)	IDLH			AEGL-1		
					PPM (15-min averaging)	ug/m3 (15-min averaging)	% of IDLH Limit	PPM (10-minute averaging)	ug/m3 (10-minute averaging)	% of AEGL-1
Methanol	S3, S5, S7	10	1.79E+04	1.60E+04	6.00E+03	7.86E+06	<1%	6.70E+02	8.78E+05	2%
Ethyl acetate	S3, S5, S7	10	4.05E+04	3.61E+04	2.00E+03	7.20E+06	<1%	NA	NA	NA
Acetic acid	S3, S5, S7	10	2.17E+04	1.93E+04	5.00E+01	1.23E+05	15.76%	NA	NA	NA
Benzene	S3, S5, S7	10	1.71E+03	1.53E+03	5.00E+02	1.60E+06	<1%	1.30E+02	4.15E+05	<1%
DL-sec-Butyl acetate	S3, S5, S7	10	3.81E+03	3.40E+03	1.70E+03	8.07E+06	<1%	NA	NA	NA
Toluene	S3, S5, S7	10	5.04E+03	4.50E+03	5.00E+02	1.88E+06	<1%	6.70E+01	2.52E+05	2%
Naphthalene	S3, S5, S7	10	4.21E+03	3.75E+03	2.50E+02	1.31E+06	<1%	NA	NA	NA
Formaldehyde	S3, S5, S7	10	6.57E+02	5.86E+02	2.00E+01	2.45E+04	2%	9.00E-01	1.10E+03	59%
Methacrolein	S3, S5, S7	10	1.53E+03	1.37E+03	NA	NA	NA	2.00E-01	5.73E+02	268%
Methacrolein	S3, S5, S7	50	1.23E+02	1.10E+02	NA	NA	NA	2.00E-01	5.73E+02	22%
HF	S3, S5, S7	10	2.41E+01	2.15E+01	3.00E+01	2.45E+04	<1%	1.00E+00	8.18E+02	3%

**Table 5-2: Maximum Predicted Concentrations and Applicable Limits (Plume Rise Scenario)**

Contaminant	Scenario	Distance of Max Concentration (m)	Max Concentration (ug/m3) (10-minute averaging)	Max Concentration (ug/m3) (15-min averaging)	IDLH			AEGL-1		
					PPM (15-min averaging)	ug/m3 (15-min averaging)	% of IDLH Limit	PPM (10-minute averaging)	ug/m3 (10-minute averaging)	% of AEGL-1
Methanol	S18, S19, S20	100	1.49E+03	1.33E+03	6.00E+03	7.86E+06	<1%	6.70E+02	8.78E+05	<1%
Ethyl acetate	S18, S19, S20	100	3.37E+03	3.01E+03	2.00E+03	7.20E+06	<1%	NA	NA	NA
Acetic acid	S18, S19, S20	100	1.81E+03	1.61E+03	5.00E+01	1.23E+05	1%	NA	NA	NA
Benzene	S18, S19, S20	100	1.42E+02	1.27E+02	5.00E+02	1.60E+06	<1%	1.30E+02	4.15E+05	<1%
DL-sec-Butyl acetate	S18, S19, S20	100	3.18E+02	2.84E+02	1.70E+03	8.07E+06	<1%	NA	NA	NA
Toluene	S18, S19, S20	100	4.20E+02	3.75E+02	5.00E+02	1.88E+06	<1%	6.70E+01	2.52E+05	<1%
Naphthalene	S18, S19, S20	100	3.51E+02	3.13E+02	2.50E+02	1.31E+06	<1%	NA	NA	NA
Formaldehyde	S18, S19, S20	100	5.48E+01	4.89E+01	2.00E+01	2.45E+04	<1%	9.00E-01	1.10E+03	5%
Methacrolein	S18, S19, S20	100	1.28E+02	1.14E+02	NA	NA	NA	2.00E-01	5.73E+02	22%
HF	S18, S19, S20	100	2.01E+00	1.79E+00	3.00E+01	2.45E+04	<1%	1.00E+00	8.18E+02	<1%

## 5.2 Results

Results indicate that the highest modeled concentrations occurred at a distance of 10 m from the source under the no plume rise scenario. Methacrolein was the only contaminant predicted to exceed a short-term exposure limit, with a 10-minute average concentration of  $1.53 \times 10^3$  ug/m<sup>3</sup>, corresponding to 268% of the applicable AEGL-1 limit ( $5.75 \times 10^2$ ). At this 10 m distance, the predicted methacrolein concentration is approximately 162% of the AEGL-2, and remains below the AEGL-3 threshold, at approximately 12.5%. At a distance of 50 m, the predicted Methacrolein concentration decreased to  $1.23 \times 10^2$  ug/m<sup>3</sup> for the 10-minute averaging period, which corresponds to 22% of the AEGL-1 limit.

For the plume rise scenario, the highest modeled concentrations occurred at a distance of 100 m from the source. Under these conditions, no contaminants were predicted to exceed applicable short-term exposure limits.

## 5.3 Assessment of Contaminants with no MECP POI Limits

Contaminants without established MECP POI limits were assessed using their *de minimis* concentrations to determine whether they could be considered insignificant. In accordance with the MECP *Procedure for Preparing an ESDM Report*, if measured concentrations were below 0.1 µg/m<sup>3</sup> (24-hour average) or 0.3 µg/m<sup>3</sup> (half-hour average), the contaminant was deemed insignificant. This is defined by the MECP as the *de minimis* concentration.

Seven contaminants without MECP POI limits were emitted at concentrations exceeding the *de minimis* thresholds, which classifies them as significant for this assessment. These contaminants include:

- Hydrogen
- Ethyl methyl carbonate
- 2,3,3-Trimethylpentane
- 4-Methyl-2-heptanol
- 2-Ethylhexyl formate
- 3,4-Dimethylcyclohexanol
- Eladic acid methyl ester.

De minimis thresholds are based on MECP POI limits, which are intended for comparison with ground level concentrations from releases during normal, ongoing facility operations. Applying these thresholds to a one-time emergency release event is therefore conservative. None of the contaminants assessed against *de minimis* thresholds had short-term exposure limits established under IDLH or AEGL. Because *de minimis* thresholds are inherently conservative, they provide a protective basis for comparison; however no further short-term assessment was conducted given the absence of applicable exposure limits.

## 5.4 Averaging Times

Concentrations for averaging times that are not available from the modeling (10-minute, 15-minute, 30-minute) are calculated using the conversion formula set out in s. 17 of Ontario Regulation 419/05 shown below:

$$C_0 = C_1 \times \left(\frac{t_1}{t_0}\right)^n$$

Where:

- $C_0$  is the concentration at the new averaging period
- $C_1$  is the concentration at the known averaging period
- $t_0$  is the new averaging period (10-Min, 1/2-Hour, 30-Day)
- $t_1$  is the known averaging period (usually 1-hr)
- $n$  is 0.28

## 5.5 POI Comparison to Previous Assessment

Table 5-3 provides a comparison of the maximum predicted POI concentrations from the current weather scenario assessment against those reported in the previous ESDM report.

POI concentrations under the weather scenario assessment exceeded those reported in the previous ESDM assessment because the calculation methodology changed and now accounts for atmospheric stability and varying weather conditions. Atmospheric stability significantly influences weather dispersion.

- Stable conditions limit vertical mixing, causing pollutants to remain concentrated near the ground and close to the source.
- Unstable conditions enhance vertical mixing, dispersing pollutants over a larger area and reducing ground-level concentrations.

By incorporating varying weather conditions and stability classes, the current assessment reflects worst case scenarios.

**Table 5-3: Comparison of Maximum POI Concentrations**

Contaminant	Max Concentrations from Previous ESDM Report ( $\mu\text{g}/\text{m}^3$ ) (1-hour averaging)	Max Concentration In Weather scenario Assessment – No Plume Rise ( $\mu\text{g}/\text{m}^3$ ) (1-hour averaging)	Max Concentration In Weather Scenario Assessment – Plume Rise ( $\mu\text{g}/\text{m}^3$ ) (1-hour averaging)
Hydrogen	2.43E+04	3.93E+04	3.28E+03
Methane	2.84E+04	4.60E+04	3.84E+03
Ethylene	1.61E+03	2.60E+03	2.17E+02
Methanol	6.68E+03	1.08E+04	9.02E+02
Ethanol	5.28E+03	8.54E+03	7.12E+02
Methyl acetate	1.51E+03	2.45E+03	2.05E+02
Ethyl acetate	1.51E+04	2.45E+04	2.04E+03
Dimethyl carbonate	5.05E+04	8.17E+04	6.81E+03

Brookfield Renewables - Owner's Engineer for South March BESS  
Air Quality Assessment in Emergency Fire Scenario Under Variable Weather Scenarios - April 20, 2026

Contaminant	Max Concentrations from Previous ESDM Report ( $\mu\text{g}/\text{m}^3$ ) (1-hour averaging)	Max Concentration In Weather scenario Assessment – No Plume Rise ( $\mu\text{g}/\text{m}^3$ ) (1-hour averaging)	Max Concentration In Weather Scenario Assessment – Plume Rise ( $\mu\text{g}/\text{m}^3$ ) (1-hour averaging)
Acetic acid	8.11E+03	1.31E+04	1.09E+03
Benzene	6.39E+02	1.03E+03	8.63E+01
DL-sec-Butyl acetate	1.43E+03	2.31E+03	1.92E+02
Ethyl methyl carbonate	5.32E+04	8.62E+04	7.18E+03
2,3,4-Trimethylpentane	1.87E+03	3.03E+03	2.52E+02
2,3,3-Trimethylpentane	2.80E+03	4.54E+03	3.78E+02
Toluene	1.88E+03	3.05E+03	2.54E+02
3-Methylheptane	2.34E+03	3.78E+03	3.15E+02
Cyclopentanone	1.38E+03	2.23E+03	1.86E+02
Diethyl carbonate	1.45E+03	2.35E+03	1.96E+02
2,2,4-Trimethylhexane	1.57E+03	2.55E+03	2.12E+02
1-Octene	9.18E+02	1.49E+03	1.24E+02
Octane	3.27E+03	5.30E+03	4.41E+02
Xylene	1.74E+03	2.81E+03	2.34E+02
2-Phenyl-1-propene	4.35E+02	7.04E+02	5.87E+01
4-Methyl-2-heptanol	5.33E+03	8.62E+03	7.19E+02
2-Octanol	5.86E+03	9.49E+03	7.91E+02
2-Ethylhexanol	5.27E+04	8.54E+04	7.12E+03
Benzoic acid	4.99E+02	8.09E+02	6.74E+01
2-Ethylhexyl formate	2.11E+03	3.42E+03	2.85E+02
Naphthalene	1.57E+03	2.55E+03	2.12E+02
3,4-Dimethylcyclohexanol	2.10E+03	3.40E+03	2.83E+02
Decane	2.91E+03	4.71E+03	3.93E+02
1-Decene	2.29E+03	3.72E+03	3.10E+02
1-Nonanal	2.33E+03	3.77E+03	3.14E+02
Propylene tetramer	3.44E+03	5.57E+03	4.65E+02
Trimethylene glycol monomethyl ether	1.84E+03	2.98E+03	2.49E+02
1-Dodecanol	5.33E+03	8.64E+03	7.20E+02
2,2,4-trimethyl-1,3-pentanediol Diisobutyrate	3.49E+05	5.65E+05	4.71E+04
Methyl palmitate	7.74E+03	1.25E+04	1.05E+03
Eladic acid methyl ester	1.58E+04	2.55E+04	2.13E+03
Methyl stearate	3.66E+03	5.93E+03	4.94E+02
Sulfur dioxide	5.24E+01	8.48E+01	7.07E+00
Hydrogen sulfide	2.79E+01	4.51E+01	3.76E+00
Nitrogen dioxide	9.41E+01	1.52E+02	1.27E+01
Formaldehyde	2.46E+02	3.98E+02	3.32E+01
Methacrolein	5.73E+02	9.28E+02	7.74E+01
Carbon Monoxide	2.86E+01	4.64E+01	3.87E+00
Hydrogen Fluoride	9.00E+00	1.46E+01	1.22E+00

## 6. Conclusions

The preliminary assessment indicates that modeled concentrations of several contaminants exceeded provincial MECP POI limits under conservative assumptions. However, no IDLH thresholds were exceeded in any case. Key findings include:

- **No Plume Rise Scenario:**
  - ◆ Maximum ground level concentrations occurred at the closest distance (10 m) under daytime, low-wind conditions.
  - ◆ Twenty-seven contaminants, exceeded MECP POI Limits. Of these, only Methacrolein exceeded any short-term exposure benchmarks (AEGL).
  - ◆ Methacrolein exceeded the AEGL-1 and AEGL-2 limits at 10 m from the source, however, it was below the AEGL-3 threshold at this distance.
  - ◆ Methacrolein was within all short-term exposure limits at 50 m from the source.
  - ◆ Seven contaminants assessed using *de minimis* thresholds exceeded the applicable MECP *de minimis* limits.
- **Maximum Plume Rise Scenario:**
  - ◆ Maximum ground level concentrations occurred further downwind (approximately 100 m from the source) due to increased plume rise (but at lower concentrations compared with max POI for the no plume rise case).
  - ◆ Twenty contaminants, exceeded the MECP POI limits. However, there were no contaminants that exceeded any short-term exposure benchmarks (IDLH and AEGL).
  - ◆ Seven contaminants assessed using *de minimis* thresholds exceeded the applicable MECP *de minimis* limits.

Results suggest that for the no plume rise scenario, short-term health-based benchmarks are not exceeded beyond very close distances (approximately 10 m). These concentrations decrease with distance and fall below applicable limits at 50 m from the source. For the maximum plume rise scenario at 100 m, concentrations remained below all short-term health-based benchmarks at this distance. All concentrations presented here represent ground-level predictions. These findings are conservative and based on worst-case assumptions for emissions, meteorology, and plume behavior.

## 7. References

- [1] (DNV). *Sungrow Battery Energy Storage System (BESS) PowerTitan 2.0 – Large Scale Burn Test Report*. Document No.: 10522343-SHA-R-01, Issue D, Status: Final, Date: 21 February 2025.
- [2] Hatch Ltd. *LFP Battery Storage Safety Fire Simulation Results (Version 1)*. Date: 2025
- [3] Hatch Ltd. *Battery Energy Storage System (BESS) Thermal Runaway Event – Emission Summary and Dispersion Modeling Report, Marchurst Drive*. Date: 17 July 2025.
- [4] NOAA Air Resources Laboratory. *Briggs Plume Rise Equations*. Available at: [https://www.ready.noaa.gov/documents/TutorialX/files/Rise\\_equations.pdf](https://www.ready.noaa.gov/documents/TutorialX/files/Rise_equations.pdf)
- [5] U.S. EPA. *User's Guide for the Industrial Source Complex (ISC3) Dispersion Model*. EPA-454/B-03-001, U.S. Environmental Protection Agency, Research Triangle Park, NC.
- [6] Centers for Disease Control and Prevention (CDC), National Institute for Occupational Safety and Health (NIOSH). *NIOSH Manual of Analytical Methods (NMAM), Method 7906: Particulate Fluorides and Hydrofluoric Acid by Ion Chromatography*. Available at: <https://www.cdc.gov/niosh/docs/2003-154/pdfs/7906.pdf>
- [7] Environment and Climate Change Canada. *Historical Weather Data*. Available at: [https://climate.weather.gc.ca/historical\\_data/search\\_historic\\_data\\_stations\\_e.html](https://climate.weather.gc.ca/historical_data/search_historic_data_stations_e.html)
- [8] Newport Corporation. *Introduction to Solar Radiation*. Available at: <https://www.newport.com/t/introduction-to-solar-radiation>
- [9] Centers for Disease Control and Prevention (CDC), National Institute for Occupational Safety and Health (NIOSH). *Immediately Dangerous to Life or Health (IDLH) Values*. Available at: <https://www.cdc.gov/niosh/idlh/default.html>
- [10] U.S. Environmental Protection Agency (EPA). *Compiled Acute Exposure Guideline Values (AEGs): Update July 27, 2018*. Available at: [https://www.epa.gov/sites/default/files/2018-08/documents/compiled\\_aegls\\_update\\_27jul2018.pdf](https://www.epa.gov/sites/default/files/2018-08/documents/compiled_aegls_update_27jul2018.pdf)
- [11] U.S. Environmental Protection Agency (EPA). *About Acute Exposure Guideline Levels (AEGs)*. Available at: <https://www.epa.gov/aegl/about-acute-exposure-guideline-levels-aegls>

# **Appendix A Result Tables**

Table A-1: Emission Summary of No Plume Rise Scenario

Contaminant	Scenario	Wind Direction	Max Concentration Distance (m)	Max Concentration (µg/m³)	Averaging Period	MECP POI Limit (µg/m³)	% of MECP POI Limit
Hydrogen	S3,S5,S7	S,E,W	10	3.93E+04	24 (DM)	DM (0.1<0.3)	DM
Methane	S3,S5,S7	S,E,W	10	4.60E+04	24-hour	37 330	123%
Ethylene	S3,S5,S7	S,E,W	10	2.60E+03	24-hour	40	6502%
Methanol	S3,S5,S7	S,E,W	10	1.08E+04	24-hour	4 000	271%
Ethanol	S3,S5,S7	S,E,W	10	8.54E+03	1-hour	19 000	45%
Methyl acetate	S3,S5,S7	S,E,W	10	2.45E+03	24-hour	3 000	82%
Ethyl acetate	S3,S5,S7	S,E,W	10	2.45E+04	1-hour	19 000	129%
Dimethyl carbonate	S3,S5,S7	S,E,W	10	8.17E+04	24-hour	920	8883%
Acetic acid	S3,S5,S7	S,E,W	10	1.31E+04	24-hour	2 500	525%
Benzene	S3,S5,S7	S,E,W	10	1.03E+03	Annual	0.45	44064.5%
DL-sec-Butyl acetate	S3,S5,S7	S,E,W	10	2.31E+03	24-hour	4 750	49%
Ethyl methyl carbonate	S3,S5,S7	S,E,W	10	8.62E+04	24 (DM)	DM (0.1<0.3)	DM
2,3,4-Trimethylpentane	S3,S5,S7	S,E,W	10	3.03E+03	24-hour	100	3026%
2,3,3-Trimethylpentane	S3,S5,S7	S,E,W	10	4.54E+03	24 (DM)	DM (0.1<0.3)	DM
Toluene	S3,S5,S7	S,E,W	10	3.05E+03	24-hour	2 000	153%
3-Methylheptane	S3,S5,S7	S,E,W	10	3.78E+03	24-hour	175	2161%
Cyclopentanone	S3,S5,S7	S,E,W	10	2.23E+03	24-hour	85	2621%
Diethyl carbonate	S3,S5,S7	S,E,W	10	2.35E+03	24-hour	120	1956%
2,2,4-Trimethylhexane	S3,S5,S7	S,E,W	10	2.55E+03	24-hour	175	1456%
1-Octene	S3,S5,S7	S,E,W	10	1.49E+03	24-hour	50 000	3%
Octane	S3,S5,S7	S,E,W	10	3.21E+03	10-minute	61 800	5%
Xylene	S3,S5,S7	S,E,W	10	2.81E+03	24-hour	7 300	39%
2-Phenyl-1-propene	S3,S5,S7	S,E,W	10	7.04E+02	1-hour	24 000	3%
4-Methyl-2-heptanol	S3,S5,S7	S,E,W	10	8.62E+03	24 (DM)	DM (0.1<0.3)	DM
2-Octanol	S3,S5,S7	S,E,W	10	9.49E+03	24-hour	135	7027%
2-Ethylhexanol	S3,S5,S7	S,E,W	10	8.54E+04	1-hour	600	14230%
Benzoic acid	S3,S5,S7	S,E,W	10	8.09E+02	24-hour	700	116%
2-Ethylhexyl formate	S3,S5,S7	S,E,W	10	3.42E+03	24 (DM)	DM (0.1<0.3)	DM
Naphthalene	S3,S5,S7	S,E,W	10	2.55E+03	24-hour	22.5	11317%
3,4-Dimethylcyclohexanol	S3,S5,S7	S,E,W	10	3.40E+03	24 (DM)	DM (0.1<0.3)	DM
Decane	S3,S5,S7	S,E,W	10	4.71E+03	1-hour	60 000	8%
1-Decene	S3,S5,S7	S,E,W	10	3.72E+03	24-hour	60 000	6%
1-Nonanal	S3,S5,S7	S,E,W	10	3.77E+03	24-hour	75	5024%
Propylene tetramer	S3,S5,S7	S,E,W	10	5.57E+03	24-hour	22	25333%
Trimethylene glycol monomethyl ether	S3,S5,S7	S,E,W	10	2.98E+03	24-hour	135	2210%
1-Dodecanol	S3,S5,S7	S,E,W	10	8.64E+03	24-hour	75	11517%
2,2,4-trimethyl-1,3-pentanediol Diisobutyrate	S3,S5,S7	S,E,W	10	5.65E+05	24-hour	420	134573%
Methyl palmitate	S3,S5,S7	S,E,W	10	1.25E+04	24-hour	120	10447%
Eladic acid methyl ester	S3,S5,S7	S,E,W	10	2.55E+04	24 (DM)	DM (0.1<0.3)	DM
Methyl stearate	S3,S5,S7	S,E,W	10	5.93E+03	24-hour	15	39535%
Sulfur dioxide	S3,S5,S7	S,E,W	10	8.48E+01	1-hour	690	12%
Hydrogen sulfide	S3,S5,S7	S,E,W	10	4.51E+01	24-hour	70	64%
Nitrogen dioxide	S3,S5,S7	S,E,W	10	1.52E+02	24-hour	200	76%
Formaldehyde	S3,S5,S7	S,E,W	10	3.98E+02	24-hour	65	612%
Methacrolein	S3,S5,S7	S,E,W	10	9.28E+02	24-hour	1.2	77359%
Carbon Monoxide	S3,S5,S7	S,E,W	10	5.63E+01	1/2-hour	6 000	<1%
HF	S3,S5,S7	S,E,W	10	1.46E+01	24-hour	0.86	1695%

\*DM = de minimis concentration as defined by the MECP.

Table A-2: Emission Summary Given Plume Rise Scenario

Contaminant	Scenario	Wind Direction	Max Concentration Distance (m)	Max Concentration (µg/m³)	Averaging Period	MECP POI Limit (µg/m³)	% of MECP POI Limit
Hydrogen	S18,S19,S20	S,E,W	100	3.28E+03	24 (DM)	DM (0.1<0.3)	DM
Methane	S18,S19,S20	S,E,W	100	3.84E+03	24-hour	37 330	10%
Ethylene	S18,S19,S20	S,E,W	100	2.17E+02	24-hour	40	542%
Methanol	S18,S19,S20	S,E,W	100	9.02E+02	24-hour	4 000	23%
Ethanol	S18,S19,S20	S,E,W	100	7.12E+02	1-hour	19 000	4%
Methyl acetate	S18,S19,S20	S,E,W	100	2.05E+02	24-hour	3 000	7%
Ethyl acetate	S18,S19,S20	S,E,W	100	2.04E+03	1-hour	19 000	11%
Dimethyl carbonate	S18,S19,S20	S,E,W	100	6.81E+03	24-hour	920	741%
Acetic acid	S18,S19,S20	S,E,W	100	1.09E+03	24-hour	2 500	44%
Benzene	S18,S19,S20	S,E,W	100	8.63E+01	Annual	0.45	3673.8%
DL-sec-Butyl acetate	S18,S19,S20	S,E,W	100	1.92E+02	24-hour	4 750	4%
Ethyl methyl carbonate	S18,S19,S20	S,E,W	100	7.18E+03	24 (DM)	DM (0.1<0.3)	DM
2,3,4-Trimethylpentane	S18,S19,S20	S,E,W	100	2.52E+02	24-hour	100	252%
2,3,3-Trimethylpentane	S18,S19,S20	S,E,W	100	3.78E+02	24 (DM)	DM (0.1<0.3)	DM
Toluene	S18,S19,S20	S,E,W	100	2.54E+02	24-hour	2 000	13%
3-Methylheptane	S18,S19,S20	S,E,W	100	3.15E+02	24-hour	175	180%
Cyclopentanone	S18,S19,S20	S,E,W	100	1.86E+02	24-hour	85	219%
Diethyl carbonate	S18,S19,S20	S,E,W	100	1.96E+02	24-hour	120	163%
2,2,4-Trimethylhexane	S18,S19,S20	S,E,W	100	2.12E+02	24-hour	175	121%
1-Octene	S18,S19,S20	S,E,W	100	1.24E+02	24-hour	50 000	<1%
Octane	S18,S19,S20	S,E,W	100	2.67E+02	10-minute	61 800	<1%
Xylene	S18,S19,S20	S,E,W	100	2.34E+02	24-hour	7 300	3%
2-Phenyl-1-propene	S18,S19,S20	S,E,W	100	5.87E+01	1-hour	24 000	<1%
4-Methyl-2-heptanol	S18,S19,S20	S,E,W	100	7.19E+02	24 (DM)	DM (0.1<0.3)	DM
2-Octanol	S18,S19,S20	S,E,W	100	7.91E+02	24-hour	135	586%
2-Ethylhexanol	S18,S19,S20	S,E,W	100	7.12E+03	1-hour	600	1186%
Benzoic acid	S18,S19,S20	S,E,W	100	6.74E+01	24-hour	700	10%
2-Ethylhexyl formate	S18,S19,S20	S,E,W	100	2.85E+02	24 (DM)	DM (0.1<0.3)	DM
Naphthalene	S18,S19,S20	S,E,W	100	2.12E+02	24-hour	22.5	944%
3,4-Dimethylcyclohexanol	S18,S19,S20	S,E,W	100	2.83E+02	24 (DM)	DM (0.1<0.3)	DM
Decane	S18,S19,S20	S,E,W	100	3.93E+02	1-hour	60 000	<1%
1-Decene	S18,S19,S20	S,E,W	100	3.10E+02	24-hour	60 000	<1%
1-Nonanal	S18,S19,S20	S,E,W	100	3.14E+02	24-hour	75	419%
Propylene tetramer	S18,S19,S20	S,E,W	100	4.65E+02	24-hour	22	2112%
Trimethylene glycol monomethyl ether	S18,S19,S20	S,E,W	100	2.49E+02	24-hour	135	184%
1-Dodecanol	S18,S19,S20	S,E,W	100	7.20E+02	24-hour	75	960%
2,2,4-trimethyl-1,3-pentanediol Diisobutyrate	S18,S19,S20	S,E,W	100	4.71E+04	24-hour	420	11220%
Methyl palmitate	S18,S19,S20	S,E,W	100	1.05E+03	24-hour	120	871%
Eladic acid methyl ester	S18,S19,S20	S,E,W	100	2.13E+03	24 (DM)	DM (0.1<0.3)	DM
Methyl stearate	S18,S19,S20	S,E,W	100	4.94E+02	24-hour	15	3296%
Sulfur dioxide	S18,S19,S20	S,E,W	100	7.07E+00	1-hour	690	1%
Hydrogen sulfide	S18,S19,S20	S,E,W	100	3.76E+00	24-hour	70	5%
Nitrogen dioxide	S18,S19,S20	S,E,W	100	1.27E+01	24-hour	200	6%
Formaldehyde	S18,S19,S20	S,E,W	100	3.32E+01	24-hour	65	51%
Methacrolein	S18,S19,S20	S,E,W	100	7.74E+01	24-hour	1.2	6450%
Carbon Monoxide	S18,S19,S20	S,E,W	100	4.69E+00	1/2-hour	6 000	<1%
HF	S18,S19,S20	S,E,W	100	1.22E+00	24-hour	0.86	141%

\*DM = de minimis concentration as defined by the MECP.

# **Appendix B**

## **DNV Clarification Letter**

To Mr. Cui Zhongchang  
Sungrow Power Supply Co., Ltd.  
No.1699 Xiyou Rd., New & High Technology Industrial Development Zone,  
Hefei, 230088, Anhui, China

DNV China Company Limited  
House No. 9, Hongqiao State Guest  
Hotel, No. 1591 Hongqiao Road,  
Changning District, 200030, Shanghai,  
China

**Our reference:**

10522343

**Your reference:**

Sungrow BESS PowerTitan 2.0 Large  
Burn Test (OPP-00360839)

**Date:**

2026-03-11

**Subject: Clarification on the Test Report (No. 10522343-SHA-R-01, Issue E)**

To whom it may concern:

In the report for *Sungrow BESS PowerTitan 2.0 Large Scale Burn Test* (No. 10522343-SHA-R-01, Issue E), Subsection 5.2 states:

*DNV notes that the test plan called for the capture of discrete gas samples at 5 minute intervals following the ignition of a fire within the enclosure and then every 15 minutes after the fire had died down. Toxic gases were to be tested in the samples, including CO, HCl, HF, HCN, H<sub>2</sub>S, and phosphorus components specific to LFP cells. During the testing, Sungrow captured 15 gas samples at each of the two sampling locations. The interval between gas samples collected was as large as 3 hours and 25 minutes. The only gas of interest tested for in the discrete samples by the testing laboratory was hydrogen sulfide.*

The last sentence indicates that the samples contained hydrogen sulfide as the only toxic gas, while the other gases of interest were not detected by the laboratory analysis. This clarification is provided to avoid any misunderstanding.

Please contact us if you have any questions regarding this letter.

Sincerely,  
DNV China Company Limited



By: \_\_\_\_\_  
Name: Symbol Jialin Zhao  
Title: Senior Consultant, Energy Storage APAC  
+86 18688491795  
Jialin.Symbol.Zhao@dnv.com