

LEGEND

- EX STORM SEWER
- EX SANITARY SEWER
- EX WATERMAIN
- PROP STORM SEWER
- PROP SANITARY SEWER
- PROP WATERMAIN
- PROP ASPHALT AREA
- PROP FLOOR SUBDRAIN

NOTES:
SEWER TO BE INSULATED AS PER OPSD 1109.030 (NOTE: CONC PIPE CLASS TO BE 100-D)

NOTES:
ORIFICE PLATES TO BE PLACED ON CBM13, EX MH1 AND DCBMH5. SEE DRAWING C012 FOR ORIFICE PLATE LOCATION, SIZE AND INVERTS.

BUILDING SLAB TO HAVE SUBDRAIN DRAINAGE SYSTEM. DRAINAGE SYSTEM TO CONNECT TO STORM SYSTEM. SEE MECHANICAL / STRUCTURAL DRAWINGS FOR DRAINAGE SYSTEM DETAILS.

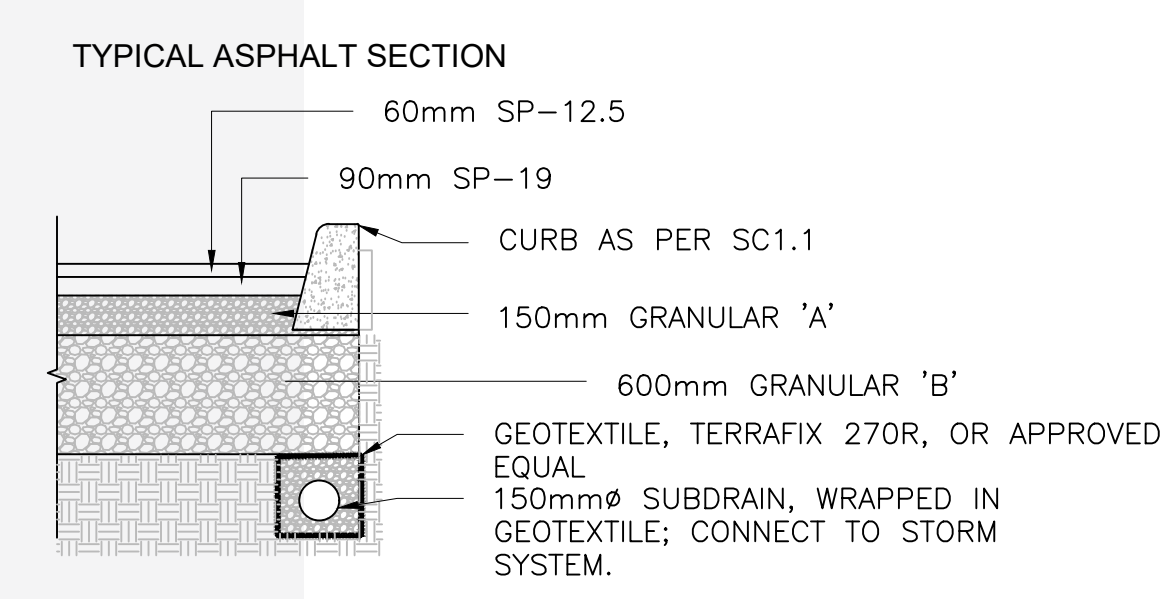

NOTES:
EXISTING UTILITIES, STORM AND SANITARY SYSTEMS TO BE LOCATED AND CONFIRMED IN FIELD PRIOR TO INSTALLATION OF SANITARY OUTLET. DISCREPANCIES ARE TO BE REPORTED TO THE ENGINEER.

ALL CROSSINGS OF UTILITIES, SEWERS, WATERMAINS AND STRUCTURES TO BE SUPPORTED AND PROTECTED WITHIN THE TRENCH WHERE SANITARY SEWERS, STORM SEWERS AND WATERMAINS TO BE INSTALLED WITHIN EXISTING PAVED AREAS TO BE INSTALLED WITH TRENCH BOX STORM SEWER AND SERVICES ARE TO BE INSULATED AS PER OPSD 1109.030 WHERE COVER IS LESS THAN 1.5m. SEWER CONNECTIONS TO THE BUILDING TO BE TERMINATED 1m FROM BUILDING AND CAPPED.

NOTES:
THE STORMWATER INFRASTRUCTURE CONSTRUCTION ON THE NORTH AND WEST SIDES OF THE NEW GARAGE MUST BE COMPLETED IN PHASES PRIOR TO NEW GARAGE FOUNDATION EXCAVATION IN ORDER TO MINIMIZE IMPACTS TO BUS AND CONSTRUCTION TRAFFIC CIRCULATION. CONTRACTOR MUST SUBMIT A PHASING PLAN FOR CITY'S REVIEW AND APPROVAL. BUS ACCESS TO FUELLING STATION AND BUS EXIT AT BELFAST TO BE MAINTAINED.

NOTES:
THE SANITARY LINE CONSTRUCTION IS REQUIRED TO BE COMPLETED IN PHASES IN ORDER TO MINIMIZE IMPACTS TO STAFF PARKING AND MAINTAIN CIRCULATION. GENERAL CONTRACTOR MUST SUBMIT A PHASING PLAN FOR CITY'S REVIEW AND APPROVAL

NOTES:
THE CONSTRUCTION IN THIS AREA IS REQUIRED TO BE COORDINATED WITH THE CITY/OC TRANSPO IN ORDER TO MINIMIZE IMPACTS TO STAFF PARKING AND MAINTAIN CIRCULATION ONCE THE STORMWATER, WATER SUPPLY LINE AND PAVING IS COMPLETED THIS AREA MUST BE IMMEDIATELY RETURNED TO THE STAFF PARKING AREA.

Ottawa
INFRASTRUCTURE SERVICES
DESIGN AND CONSTRUCTION

SERVICES D'INFRASTRUCTURE
DIRECTION DE CONCEPTION ET DE CONSTRUCTION

FOR / POUR
Client - Department
Infrastructure and Water Services Department
Design & Construction

CONSULTANT
AECOM

PRIME:
AECOM Canada Architects Ltd.
50 Spadina Avenue, Suite 290
Kitchener, Ontario, N2P 0A4

grc architects

SUBCONSULTANT:
GRC ARCHITECTS INC.
47 Clarence Street, Suite 401
Ottawa, Ontario, K1N 9K1

REVISIONS:

NO.	DESCRIPTION	DATE	BY	CHKD
1	ISSUED FOR SPA	2020/03/26	TG	
2	REISSUED FOR TENDER	2020/03/26	TG	
3	REISSUED FOR TENDER	2020/03/12	TG	
4	ISSUED FOR TENDER	2020/12/15	TG	

DRAWING TITLE
1:1 SCALE

ARCHITECT / ARCHITECTE
T. J. GRANT
PROFESSEUR D'INGENIERIE
PROVINCE DE L'ONTARIO

CONSULTANT / EXPERT-CONSEIL

PROJECT / LOCATION / PROJET / ENDROIT
OTC ZEB-New Garage

Enter address here.

OTTAWA, ONTARIO

DRAWING / DESSIN
SITE SERVICING PLAN

FILE NUMBER
D07-12-25-0095
PLAN NUMBER
19357

BUSINESS ENTITY / NUMERO DE L'ENTITE
OMF1
CITY PROJECT NO. / NUMERO DE PROJET
60716350

SHEET NO. / FEUILLE NO.
C006