

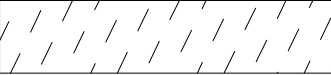

LEGEND

-  ASPHALT AND GRANULAR A REMOVAL
-  ITEM TO BE REMOVED
-  ITEM TO BE REMOVED AND REPLACED
-  EXISTING SOIL BELOW THE LIMITS OF THE NEW GARAGE FOUNDATIONS MUST BE REMOVED TO LEVEL OF THE SHALEY GLACIAL TILL AND BUILT UP WITH ENGINEERED FILL TO THE UNDERSIDE OF THE FOOTING. REFER TO GEOTECHNICAL REPORT.

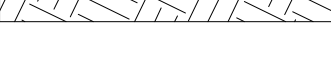
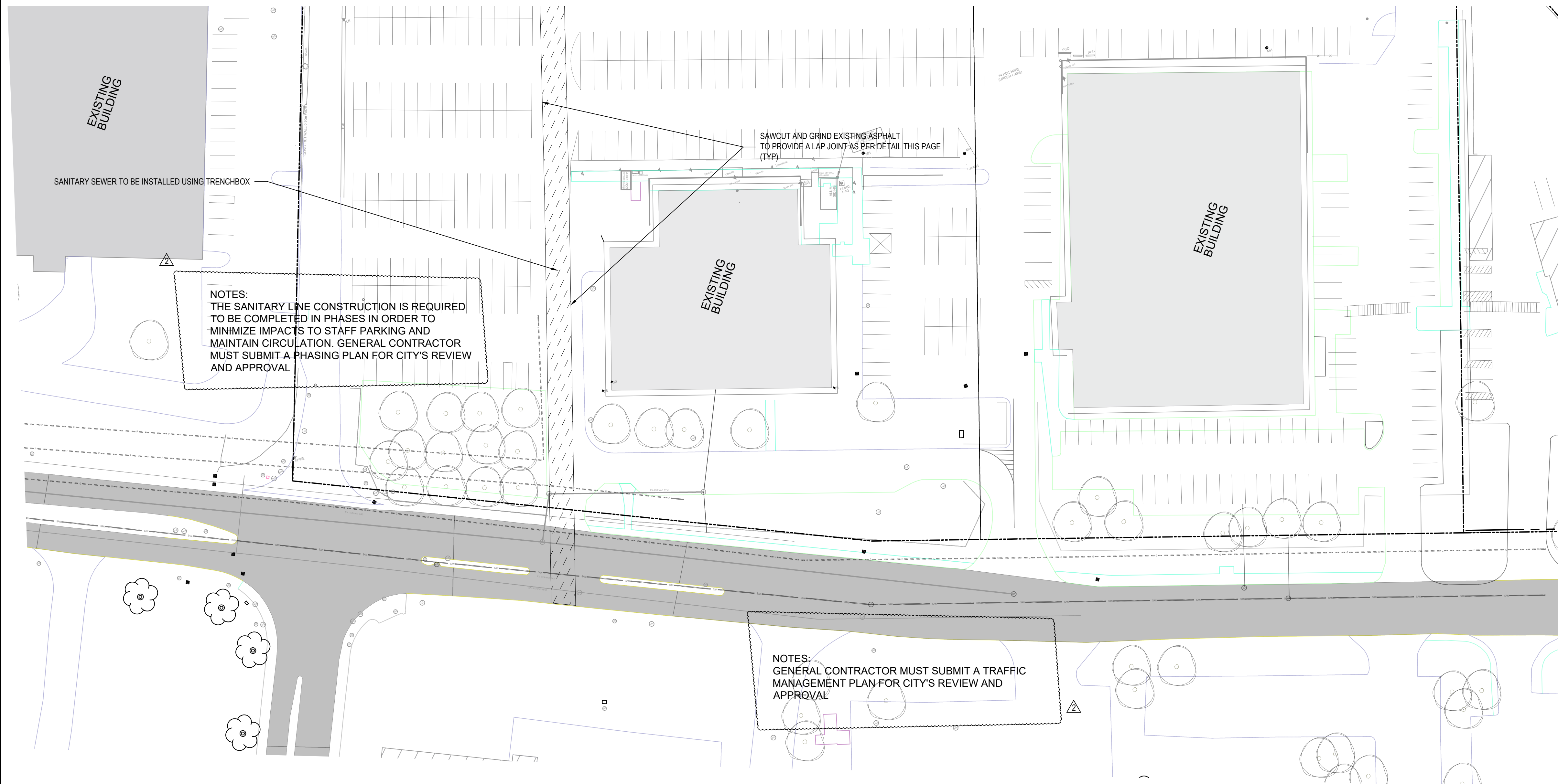
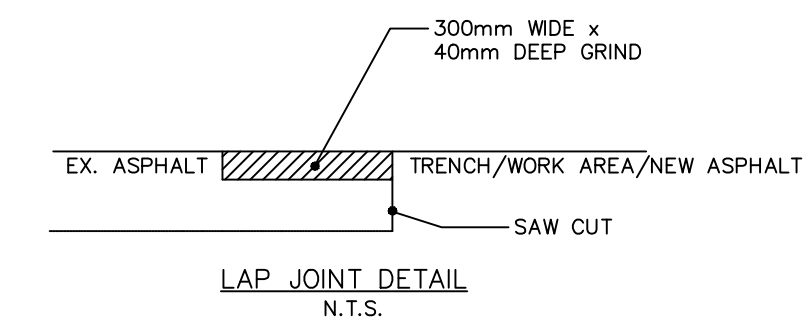

SERVICES D'INFRASTRUCTURE
DIRECTION DE CONCEPTION ET DE CONSTRUCTION

FOR / POUR
Client - Department
Infrastructure and Water Services Department
Design & Construction



PRIME:
AECOM Canada Architects Ltd.
50 Sportsworld Crossing Road, Suite 200
Kitchener, Ontario, N2P 0A4



SUBCONSULTANT:
GRC ARCHITECTS INC.
47 Clarence Street, Suite 401
Ottawa, Ontario, K1N 9K1

NOTE:
IT IS THE RESPONSIBILITY OF THE CONTRACTORS TO INFORM THEMSELVES OF THE EXACT LOCATION OF, AND ASSUME ALL LIABILITY FOR DAMAGE TO ALL UTILITIES, SERVICES AND STRUCTURES WHETHER ABOVE GROUND OR BELOW GRADE BEFORE COMMENCING THE WORK. SUCH INFORMATION IS NOT NECESSARILY SHOWN ON THE DRAWING, AND WHERE SHOWN, THE ACCURACY CANNOT BE GUARANTEED.
WITH THE SOLE EXCEPTION OF THE BENCHMARKS SPECIFICALLY DESCRIBED FOR THIS PROJECT, NO ELEVATION INDICATED OR ASSUMED HEREON IS TO BE USED AS A REFERENCE ELEVATION FOR ANY PURPOSE.

NUMBER	MILESTONE/FAIT SAILLANT	DATE (Y/M/D)	INITIALS
3	ISSUED FOR SPA	2020/03/26	TG
2	REISSUED FOR TENDER	2020/03/12	TG
1	ISSUED FOR TENDER	2020/12/15	TG

DESIGNED BY / CONCEVU PAR: TG/SS
DRAWN BY / DESINE PAR: SS
SCALE / ECHELLE: 1 : 500

DETAIL NUMBER: 1
DRAWING TITLE: A1.1
SCALE: 1 : 500
SHEET NUMBER

THIS DRAWING IS THE PROPERTY OF THE CITY OF OTTAWA AND ALL COPYRIGHT IS RESERVED. DIMENSIONS ON DRAWINGS ARE FOR ESTIMATING PURPOSES ONLY. IT IS THE RESPONSIBILITY OF EACH CONTRACTOR AND SUB-CONTRACTOR OR CONSULTANT TO CHECK AND VERIFY ALL DIMENSIONS AND CONDITIONS ON SITE. NOTIFY OWNER OF ANY ERRORS OR OMISSIONS PRIOR TO COMMENCING THE WORK. DO NOT SCALE THE DRAWINGS.

CE DESSIN CONSTITUE LA PROPRIETE DE LA VILLE D'OTTAWA ET TOUT DROIT D'AUTEUR EST RESERVE. LES DIMENSIONS UTILISEES LE SONT A DES FINS DESTINATION SEULEMENT. IL INCOMBE A CHAQUE ENTREPRENEUR, SOUS-CONTRACTANT OU CONSULTANT DE VERIFIER TOUTES LES DIMENSIONS ET LES CONDITIONS SUR LE CHANTIER. VEULEZ INFORMER LE PROPRIETAIRE DE TOUTE ERREUR OU OMISSION AVANT D'ENTAMER LES TRAVAUX. NE DRESSEZ PAS LES PLANS A L'ECHELLE.

ARCHITECT / ARCHITECTE: T. J. GRANT
CONSULTANT / EXPERT-CONSEIL: T. J. GRANT
PROFESSIONAL ENGINEER
26 MAR 2020
PROVINCE OF ONTARIO

CONSULTANT / EXPERT-CONSEIL: T. J. GRANT

PROJECT / LOCATION / PROJET / ENDROIT: OTC ZEB-New Garage

Enter address here,
OTTAWA, ONTARIO

DRAWING / DESSIN: EXISTING CONDITIONS AND REMOVALS

BUSINESS ENTITY / NUMERO DE L'ENTITE: OMF1
BUILDING NUMBER / NUMERO DU BATIMENT: 60716350
SHEET NO. / FEUILLE No: C004
CITY PROJECT NO. / NUMERO DE PROJET: 60716350
CONS. PROJECT NO. / NUMERO DE PROJET: 60716350

File Number D07-12-25-0095
Plan Number 19357