

GENERAL NOTES:

- COORDINATE AND SCHEDULE ALL WORK WITH OTHER TRADES AND CONTRACTORS.
- DETERMINE THE EXACT LOCATION, SIZE, MATERIAL AND ELEVATION OF ALL EXISTING UTILITIES PRIOR TO COMMENCING CONSTRUCTION. PROTECT AND ASSUME RESPONSIBILITY FOR ALL EXISTING UTILITIES WHETHER OR NOT SHOWN ON THIS DRAWING.
- OBTAIN ALL NECESSARY PERMITS AND APPROVALS FROM THE CITY OF OTTAWA BEFORE COMMENCING CONSTRUCTION.
- BEFORE COMMENCING CONSTRUCTION OBTAIN AND PROVIDE PROOF OF COMPREHENSIVE, ALL RISK AND OPERATIONAL LIABILITY INSURANCE FOR \$5,000,000.00. INSURANCE POLICY TO NAME OWNERS, ENGINEERS AND ARCHITECTS AS CO-INSURED.
- RESTORE ALL DISTURBED AREAS ON-SITE AND OFF-SITE, INCLUDING TRENCHES AND SURFACES ON PUBLIC ROAD ALLOWANCES TO EXISTING CONDITIONS OR BETTER TO THE SATISFACTION OF THE CITY OF OTTAWA AND ENGINEER.
- REMOVE FROM SITE ALL EXCESS EXCAVATED MATERIAL, ORGANIC MATERIAL AND DEBRIS UNLESS OTHERWISE INSTRUCTED BY ENGINEER. EXCAVATE AND REMOVE FROM SITE ANY CONTAMINATED MATERIAL. ALL CONTAMINATED MATERIAL SHALL BE DISPOSED OF AT A LICENSED LANDFILL FACILITY.
- ALL DIMENSIONS AND INVERTS MUST BE VERIFIED PRIOR TO CONSTRUCTION. IF THERE IS ANY DISCREPANCY THE CONTRACTOR IS TO NOTIFY THE ENGINEER PROMPTLY.
- ALL ELEVATIONS ARE GEODETIC AND ARE REFERRED TO THE CGVD28 GEODETIC DATUM. BEARINGS ARE DERIVED FROM MTM ZONE 9 (NAD-83, ORIGINAL), PRIOR TO CONSTRUCTION, THE CONTRACTOR IS TO RETAIN A SURVEYOR TO PROVIDE A LOCAL SITE BENCHMARK.
- REFER TO GEOTECHNICAL INVESTIGATION REPORT PROPOSED RESIDENTIAL DEVELOPMENT, COPPERWOOD FLATS BLOCK 127, 1075 MARCH ROAD, OTTAWA ONTARIO, P6613-1, REVISION 4 (DATED AUGUST 1, 2025), PREPARED BY PATERSON GROUP FOR SUBSURFACE CONDITIONS, CONSTRUCTION RECOMMENDATIONS AND GEOTECHNICAL INSPECTION REQUIREMENTS. THE GEOTECHNICAL CONSULTANT IS TO REVIEW ON-SITE CONDITIONS AFTER EXCAVATION PRIOR TO PLACEMENT OF THE GRANULAR MATERIAL.
- REFER TO ARCHITECT'S AND LANDSCAPE ARCHITECT'S DRAWINGS FOR BUILDING AND HARD SURFACE AREAS AND DIMENSIONS.
- REFER TO THE STORMWATER MANAGEMENT REPORT No. R-2025-009, DATED August 19th, 2025 PREPARED BY NOVATECH.
- SAW CUT AND KEYGRIND ASPHALT AT ALL ROAD CUTS AND ASPHALT TIE IN POINTS AS PER CITY OF OTTAWA STANDARDS (R10 AND R25).
- PROVIDE LINE/PARKING PAINTING.
- CONTRACTOR TO PROVIDE THE CONSULTANT WITH A GENERAL PLAN OF SERVICES INDICATING ALL SERVING AS-BUILT INFORMATION SHOWN ON THIS PLAN. AS-BUILT INFORMATION MUST INCLUDE: PIPE MATERIAL, SIZES, LENGTHS, SLOPES, INVERT AND T/G ELEVATIONS, STRUCTURE LOCATIONS, VALVE AND HYDRANT LOCATIONS, TWM ELEVATIONS AND ANY ALIGNMENT CHANGES, ETC.
- CONTRACTOR IS RESPONSIBLE FOR ALL LAYOUT FOR CONSTRUCTION PURPOSES.

SEWER NOTES:

- SUPPLY AND CONSTRUCT ALL SEWERS AND APPURTENANCES IN ACCORDANCE WITH THE MOST CURRENT CITY OF OTTAWA STANDARDS AND SPECIFICATIONS.
- SPECIFICATIONS:

ITEM	SPEC. No.	REFERENCE
SANITARY/STORMCATCHBASIN MANHOLE (12000)	701.010	OPSD
STORM MANHOLE (15000)	701.011	OPSD
CATCHBASIN (600/600)	705.010	OPSD
CATCHBASIN FRAME AND COVER	400.020	OPSD
STORMS/SANITARY MH FRAME	S25	CITY OF OTTAWA
SANITARY COVER	S24	CITY OF OTTAWA
STORM COVER (CLOSED)	S24.1	CITY OF OTTAWA
STORM COVER (OPEN)	S28.1	CITY OF OTTAWA
SEWER TRENCH	S6 & S7	CITY OF OTTAWA
STORM SEWER <= 450mmØ	PVC DR 35/UNLESS SPECIFIED OTHERWISE	CITY OF OTTAWA
STORM SEWER >= 450mmØ	PVC DR 65 (UNLESS SPECIFIED OTHERWISE)	CITY OF OTTAWA
SANITARY SEWER (LESS THAN 2.5M CLEAR TO WTM)	CNC DR 26	CITY OF OTTAWA
SANITARY SEWER (MORE THAN 2.5M CLEAR TO WTM)	PVC DR 35	CITY OF OTTAWA
CATCHBASIN LEAD	PVC DR 35	CITY OF OTTAWA
CATCHBASIN COVER	S19	CITY OF OTTAWA
WATERTIGHT FRAME & COVER (SANMH105 & SANMH110)	401.030	OPSD
- INSULATE ALL PIPES (SAN/STM) THAT HAVE LESS THAN 2.0m COVER WITH 50mmX1200mm HI-40 INSULATION. PROVIDE 150mm CLEARANCE BETWEEN PIPE AND INSULATION (REFER TO DETAIL).
- SERVICES ARE TO BE CONSTRUCTED TO 1.0m FROM FACE OF BUILDING AT A MINIMUM SLOPE OF 1.0% (2.0% PREFERRED)
- ALL STORM AND SANITARY LATERALS SHALL BE EQUIPPED WITH BACKFLOW PREVENTION DEVICES AS PER THE CITY OF OTTAWA STANDARD DETAILS S14 AND S14.1 OR S14.2.
- THE PIPE BEDDING FOR THE SEWER AND WATER PIPES SHOULD CONSIST OF AT LEAST 150 MM OF OPSS GRANULAR. THE BEDDING SHOULD EXTEND TO THE SPRING LINE OF THE PIPE. COVER MATERIAL FROM THE SPRING LINE TO AT LEAST 300mm ABOVE OVERTOP OF THE PIPE, SHOULD CONSIST OF OPSS GRANULAR A OR GRANULAR B TYPE II WITH MAXIMUM SIZE OF 25mm. THE BEDDING LAYER SHOULD BE INCREASED TO A MINIMUM THICKNESS OF 300mm WHERE SUBGRADE CONSISTS OF GREY SILTY ROCK. THE BEDDING AND COVER MATERIAL SHOULD BE PLACED IN MAXIMUM 225mm THICK LIFTS COMPACTED TO 95% OF THE MATERIALS STANDARD PROCTOR MAXIMUM DRY DENSITY (SPMDD).
- THE BACKFILL MATERIAL WITHIN THE BENCH ZONE (ABOUT 1.8m BELOW FINISHED GRADE) SHOULD MATCH THE SOILS EXPOSED AT THE TRENCH WALLS TO REDUCE POTENTIAL DIFFERENTIAL FROST HEAVING. THE BACKFILL SHOULD BE PLACED IN MAXIMUM 300mm THICK LOOSE LIFTS AND COMPACTED TO A MINIMUM OF 95% OF THE MATERIALS SPMDD.
- FLEXIBLE CONNECTIONS ARE REQUIRED FOR CONNECTING PIPES TO MANHOLES (FOR EXAMPLE KOR-N-SEAL, PSX; POSITIVE SEAL AND DURASEAL). THE CONCRETE CRADLE FOR THE PIPE CAN BE ELIMINATED.
- ALL STORM MANHOLES WITH PIPE SIZES LESS THAN 900mm ARE TO HAVE 300mm SUMPS UNLESS OTHERWISE INDICATED.
- CONTRACTOR TO TELEPHONE (CCTV) ALL PROPOSED SEWERS 200mm OR GREATER IN DIAMETER PRIOR TO BASE COURSE ASPHALT TO ENSURE THAT THEY ARE CLEAN AND OPERATIONAL. UPON COMPLETION OF CONTRACT, THE CONTRACTOR IS RESPONSIBLE TO FLUSH AND CLEAN ALL SEWERS & APPURTENANCES AND RE CCTV PRIOR TO ACCEPTANCE. OBTAIN APPROVAL FROM THE CITY'S SEWER OPERATIONS, PROVIDE THE CCTV INSPECTION AND REPORT TO THE ENGINEER FOR REVIEW AND APPROVAL.
- CONTRACTOR TO PROVIDE THE CONSULTANT WITH A GENERAL PLAN OF SERVICES INDICATING ALL APPLICABLE SERVICING AS-BUILT INFORMATION SHOWN ON THIS PLAN. AS-BUILT INFORMATION MUST INCLUDE: PIPE MATERIAL, SIZES, LENGTHS, SLOPES, INVERT AND T/G ELEVATIONS, STRUCTURE LOCATIONS AND ANY ALIGNMENT CHANGES, ETC.
- THE OWNER SHALL REQUIRE THAT THE SITE SERVICING CONTRACTOR PERFORM FIELD TESTS FOR QUALITY CONTROL OF ALL SANITARY SEWERS. LEAKAGE TESTING SHALL BE COMPLETED IN ACCORDANCE WITH OPS 410.07.16, 410.07.18.04 AND 407.07.24. DYE TESTING IS TO BE COMPLETED ON ALL SANITARY SERVICES TO CONFIRM PROPER CONNECTION TO THE SANITARY SEWER MAIN. THE FIELD TESTS SHALL BE PERFORMED IN THE PRESENCE OF A CERTIFIED PROFESSIONAL ENGINEER WHO SHALL SUBMIT A CERTIFIED COPY OF THE TEST RESULTS.
- ALL CATCHBASINS AND CATCHBASIN MANHOLES TO BE PROVIDED WITH MINIMUM 3 METER LONG PERFORATED SUBDRAINS EXTENDING IN TWO DIRECTIONS 300mm BELOW THE SUBGRADE LEVEL. SUBDRAIN IS TO BE PROVIDED AT THE TRANSITIONS BETWEEN DIFFERENT PAVEMENT COMPOSITIONS. THE SUBGRADE SURFACE SHOULD BE SHAPED TO PROMOTE WATER FLOW TO THE DRAINAGE LINES.
- ALL WORKS SHALL BE PERFORMED AS APPLICABLE IN ACCORDANCE WITH CITY OF OTTAWA STANDARD SPECIFICATIONS, AND IN PARTICULAR O.P.S.S. 407 AND 410.

PAVEMENT STRUCTURE:

- ACCESS LANES AND HEAVY-TRUCK PARKING AREAS
 40mm WEAR COURSE - HL-3 OR SUPERPAVE 12.5 ASPHALTIC CONCRETE
 50mm BINDER COURSE - HL-8 OR SUPERPAVE 19.0 ASPHALTIC CONCRETE
 150mm BASE - OPSS GRANULAR A CRUSHED STONE
 300mm SUBBASE - OPSS GRANULAR B TYPE II

- CAR ONLY PARKING AREAS
 50mm WEAR COURSE - HL-3 OR SUPERPAVE 12.5 ASPHALTIC CONCRETE
 150mm BASE - OPSS GRANULAR A CRUSHED STONE
 300mm SUBBASE - OPSS GRANULAR B TYPE II

- NOTE:**
- MINIMUM PERFORMANCE GRADE (PG) 58-34 ASPHALT CEMENT.
 - SUBGRADE - EITHER FILL, IN SITU SOIL OR BEDROCK OR OPSS GRANULAR TYPE I OR II MATERIAL PLACED OVER IN SITU SOIL, BEDROCK OR FILL.

REFER TO GEOTECHNICAL REPORT FOR SUBSURFACE CONDITIONS AND CONSTRUCTION RECOMMENDATIONS

WATERMAIN NOTES:

- SUPPLY AND CONSTRUCT ALL WATERMAIN AND APPURTENANCES IN ACCORDANCE WITH THE MOST CURRENT CITY OF OTTAWA STANDARDS AND SPECIFICATIONS.
- SPECIFICATIONS:

ITEM	SPEC. No.	REFERENCE
WATERMAIN TRENCHING	W17	CITY OF OTTAWA
THERMAL INSULATION IN SHALLOW TRENCHES	W22	CITY OF OTTAWA
THERMAL INSULATION BY OPEN STRUCTURES	W23	CITY OF OTTAWA
WATERMAIN CROSSING BELOW SEWER	W25.2	CITY OF OTTAWA
WATERMAIN CROSSING ABOVE SEWER	W25.2	CITY OF OTTAWA
HYDRANT	WSD-24	CITY OF OTTAWA
VALVE AND VALVE BOX	WSD-19	CITY OF OTTAWA
WATERMAIN	PVC DR 18	CITY OF OTTAWA
- SUPPLY AND CONSTRUCT ALL WATERMANS AND APPURTENANCES IN ACCORDANCE WITH THE CITY OF OTTAWA STANDARD AND SPECIFICATIONS. EXCAVATION, INSTALLATION, BACKFILL AND RESTORATION OF ALL WATERMANS WILL BE PERFORMED BY CITY OFFICIALS.
- WATERMAIN SHALL BE MINIMUM 2.4m DEPTH BELOW GRADE UNLESS OTHERWISE INDICATED. ANY WATERMAIN WITH LESS THAN 2.4m COVER WILL BE INSULATED PER THE SEWER AND WATERMAIN NOTES AND DETAIL.
- PROVIDE MINIMUM CLEARANCE BETWEEN OUTSIDE OF PIPES, AT ALL CROSSINGS AS PER CITY DETAILS W25 AND W25.2. WATERMAIN MUST HAVE A MINIMUM VERTICAL CLEARANCE OF 0.25m OVER AND 0.50m UNDER SEWERS AND ALL OTHER UTILITIES WHEN CROSSING.
- WATER SERVICE IS TO BE CONSTRUCTED TO WITHIN 1.0m OF FOUNDATION WALL AND CAPPED, UNLESS OTHERWISE INDICATED.
- CATHODIC PROTECTION REQUIRED FOR ALL IRON FITTINGS CITY OF OTTAWA STANDARD DETAILS WSD-39, 40, 41, 42, 43 AND 44.
- IF WATERMAIN MUST BE DEFLECTED TO MEET ALIGNMENT, ENSURE THAT THE AMOUNT OF DEFLECTION USED IS LESS THAN HALF THAT RECOMMENDED BY THE MANUFACTURER.

GRADING NOTES:

- ALL TOPSOIL, ORGANIC OR DELETERIOUS MATERIAL MUST BE ENTIRELY REMOVED FROM BENEATH THE PROPOSED BUILDING AND PAVED AREAS.
- EXPOSED SUB-GRADES IN PROPOSED PAVED AREAS SHOULD BE PROOF ROLLED WITH A LARGE STEEL DRUM ROLLER AND INSPECTED BY THE GEOTECHNICAL ENGINEER PRIOR TO THE PLACEMENT OF GRANULARS.
- NON-SPECIFIED EXISTING FILL ALONG WITH SITE-EXCAVATED SOIL COULD BE PLACED AS GENERAL LANDSCAPING FILL WHERE SETTLEMENT OF THE GROUND SURFACE IS OF MINOR CONCERN. THESE MATERIALS SHOULD BE SPREAD IN LIFTS WITH A MAXIMUM THICKNESS OF 300 mm AND COMPACTED BY THE TRACKS OF THE SPREADING EQUIPMENT TO MINIMIZE VOIDS. IF THIS MATERIAL IS TO BE USED TO BUILD UP THE SUBGRADE LEVEL FOR AREAS TO BE PAVED, IT SHOULD BE COMPACTED IN THIN LIFTS TO AT LEAST 95% OF THE MATERIAL'S SPMDD.
- THE PAVEMENT GRANULAR BASE AND SUBBASE SHOULD BE PLACED IN MAXIMUM 300 mm THICK LIFTS AND COMPACTED TO A MINIMUM OF 100% OF THE MATERIAL'S SPMDD USING SUITABLE COMPACTION EQUIPMENT. IF BEDROCK IS ENCOUNTERED AT THE SUBGRADE LEVEL, THE TOTAL THICKNESS OF THE PAVEMENT GRANULAR MATERIALS (BASE AND SUBBASE) COULD BE REDUCED TO 300 MM FOR THE NOTED PAVEMENT STRUCTURES. THE UPPER 300 mm OF THE BEDROCK SURFACE SHOULD BE REVIEWED AND APPROVED BY PATERSON PRIOR TO PLACING THE BASE AND SUBBASE MATERIALS. CARE SHOULD BE EXERCISED TO ENSURE THAT THE BEDROCK SUBGRADE DOES NOT HAVE DEPRESSIONS THAT WILL TRAP THE WATER.
- BACKFILL MATERIAL BELOW SIDEWALKS AND WALKWAY SUBGRADE AREAS THROUGHOUT THE SUBJECT SITE, INCLUDING ALONG THE BUILDINGS, SHOULD BE PROVIDED WITH A MINIMUM 300 MM THICK LAYER OF OPSS GRANULAR A OR OPSS GRANULAR B TYPE II CRUSHED STONE. THIS MATERIAL SHOULD BE PLACED IN MAXIMUM 300 MM THICK LOOSE LIFTS AND COMPACTED TO A MINIMUM OF 98% OF THE MATERIALS SPMDD.
- IF SOFT SPOTS DEVELOP IN THE SUBGRADE DURING COMPACTION OR DUE TO CONSTRUCTION TRAFFIC, THE AFFECTED AREAS SHOULD BE EXCAVATED AND REPLACED WITH OPSS GRANULAR B TYPE I OR II MATERIAL. THE PAVEMENT GRANULAR BASE AND SUBBASE SHOULD BE PLACED IN MAXIMUM 300 MM THICK LIFTS AND COMPACTED TO A MINIMUM OF 100% OF THE MATERIAL'S SPMDD USING SUITABLE VIBRATORY EQUIPMENT.
- ALL CURBS SHALL BE BARRIER CURB (150mm) UNLESS OTHERWISE NOTED. REFER TO CITY OF OTTAWA DETAIL SC1.1.
- GRADE AND/OR FILL BEHIND PROPOSED CURB AND BETWEEN BUILDINGS AND CURBS, WHERE REQUIRED TO PROVIDE POSITIVE DRAINAGE.
- MINIMUM OF 2% GRADE FOR ALL GRASS AREAS UNLESS OTHERWISE NOTED.
- ALL GRADES BY CURBS ARE EDGE OF PAVEMENT GRADES UNLESS OTHERWISE INDICATED.
- REFER TO LANDSCAPE PLAN FOR PLANTING AND OTHER LANDSCAPE FEATURE DETAILS.
- CONTRACTOR TO PROVIDE THE CONSULTANT WITH A GRADING PLAN INDICATING THE AS-BUILT ELEVATION OF EVERY DESIGN GRADE SHOWN ON THIS PLAN.
- ASENSITIVE MARINE CLAY TO BE REMOVED AND REPLACED WITH ENGINEERING FILL AS DIRECTED GEOTECHNICAL CONSULTANT.

EROSION AND SEDIMENT CONTROL NOTES:

THE CONTRACTOR SHALL IMPLEMENT BEST MANAGEMENT PRACTICES, TO PROVIDE FOR PROTECTION OF THE AREA DRAINAGE SYSTEM AND THE RECEIVING WATERCOURSE, DURING CONSTRUCTION ACTIVITIES. THE CONTRACTOR ACKNOWLEDGES THAT FAILURE TO IMPLEMENT APPROPRIATE EROSION AND SEDIMENT CONTROL MEASURES MAY BE SUBJECT TO PENALTIES IMPOSED BY ANY APPLICABLE REGULATORY AGENCY.

- THE OWNER AGREES TO PREPARE AND IMPLEMENT AN EROSION AND SEDIMENT CONTROL PLAN TO THE SATISFACTION OF THE CITY OF OTTAWA, APPROPRIATE TO THE SITE CONDITIONS, PRIOR TO UNDERTAKING ANY SITE ALTERATIONS (FILLING, GRADING, REMOVAL OF VEGETATION, ETC.) AND DURING ALL PHASES OF SITE PREPARATION AND CONSTRUCTION IN ACCORDANCE WITH THE CURRENT BEST MANAGEMENT PRACTICES FOR EROSION AND SEDIMENT CONTROL. SUCH AS BUT NOT LIMITED TO INSTALLING FILTER CLOTHS ACROSS MANHOLE/CATCHBASIN LIDS TO PREVENT SEDIMENTS FROM ENTERING STRUCTURES AND INSTALL AND MAINTAIN A LIGHT DUTY SILT FENCE BARRIER AS REQUIRED.
- THE CONTRACTOR SHALL PLACE FILTER BAGS UNDER THE CATCHBASIN AND MANHOLE GRATES FOR THE DURATION OF CONSTRUCTION AND WILL REMAIN IN PLACE DURING ALL PHASES OF CONSTRUCTION.
- SILT FENCING FOR ENTIRE PERIMETER OF SITE, SHALL BE UTILIZED TO CONTROL EROSION FROM THE SITE DURING CONSTRUCTION.
- THE CONTRACTOR ACKNOWLEDGES THAT FAILURE TO IMPLEMENT EROSION AND SEDIMENT CONTROL MEASURES MAY BE SUBJECT TO PENALTIES IMPOSED BY ANY APPLICABLE REGULATORY AGENCY.
- PROVIDE MUD MATS AT ALL CONSTRUCTION ACCESS POINTS TO MINIMIZE SEDIMENT TRANSPORT OFFSITE.
- EROSION AND SEDIMENT CONTROL MEASURES MAY BE MODIFIED IN THE FIELD AT THE DISCRETION OF THE CITY OF OTTAWA SITE INSPECTOR OR CONSERVATION AUTHORITY.

TYPICAL SERVICING NOTES:

- NO HORIZONTAL BENDS IN RIGHT-OF-WAY UNLESS OTHERWISE APPROVED BY THE CITY. MAXIMUM OF TWO 22.5° HORIZONTAL BENDS FOR SANITARY AND STORM SERVICES.
- 1.0 % MINIMUM SANITARY AND STORM SERVICE GRADIENT WITH 2% PREFERRED.
- SEE S7 FOR PIPE FOUNDATION, EMBEDMENT AND FINAL BACKFILL REQUIREMENTS.
- MULTIPLE TAPS WITH SADDLES IN PVC WATERMAIN SHALL BE STAGGERED AND MINIMUM 600mm APART.
- ELEVATION OF SERVICES VARIABLE DEPENDING ON GRADIENT AND/OR DEPTH OF COVER.
- ALL DIMENSIONS ARE IN MILLIMETERS.
- CONTRACTOR TO PROVIDE THE CONSULTANT WITH A GRADING PLAN INDICATING AS-BUILT ELEVATIONS OF ALL DESIGN GRADES SHOWN ON THIS PLAN.
- GRADE AND/OR FILL BEHIND PROPOSED CURB AND BETWEEN BUILDINGS AND CURBS, WHERE REQUIRED TO PROVIDE POSITIVE DRAINAGE.
- REFER TO ELECTRICAL DESIGN FOR UTILITY LOCATIONS.

PROPOSED 150mmØ WATERMAIN (1+000.0)				
STATION	SURFACE ELEVATION	TWM ELEVATION	COMMENTS	
1+000.0	86.91	84.58	300mmX150mm TEE	
1+009.1	87.05	84.65	150mmØ VALVE AND VALVE BOX	
1+011.7	87.00	85.52	CROSS ABOVE 750mmØ STM AS PER CITY OF OTTAWA STANDARD W25.2 (±0.25m CLEARANCE)	
1+017.0	86.74	84.34	45° HORIZONTAL BEND	
1+021.4	86.60	84.72	CROSS ABOVE 200mmØ SAN AS PER CITY OF OTTAWA STANDARD W25.2 (±0.25m CLEARANCE)	
1+023.6	86.64	84.24	45° HORIZONTAL BEND	
1+041.6	86.42	84.02	45° HORIZONTAL BEND	
1+044.0	86.41	84.01	150mmØ VALVE AND VALVE BOX	
1+048.3	86.52	84.05	CROSS BELOW 135mmØ SAN (±0.50m CLEARANCE)	
1+052.4	86.41	84.01	45° HORIZONTAL BEND	
1+072.1	86.14	83.74	45° HORIZONTAL BEND	
1+076.4	86.00	83.55	CROSS BELOW 135mmØ SAN (±0.50m CLEARANCE)	
1+077.9	85.95	83.55	45° HORIZONTAL BEND	
1+105.9	86.17	84.23	CROSS ABOVE 200mmØ SAN AS PER CITY OF OTTAWA STANDARD W25.2 (±0.25m CLEARANCE)	
1+111.2	86.14	83.74	45° HORIZONTAL BEND	
1+114.4	86.13	83.73	45° HORIZONTAL BEND	
1+129.1	86.70	84.30	150mmØ VALVE AND VALVE BOX	
1+132.6	86.83	84.43	45° HORIZONTAL BEND	
1+137.5	86.97	85.22	CROSS ABOVE 750mmØ STM AS PER CITY OF OTTAWA STANDARD W25.2 (±0.25m CLEARANCE)	
1+140.33	87.11	84.71	CROSS ABOVE 200mmØ SAN (±0.87m CLEARANCE)	
1+142.5	87.16	84.76	CROSS ABOVE 250mmØ STM (±0.70m CLEARANCE)	
1+153.3	87.40	85.00	150mmX150mm TEE	

PROPOSED 150mmØ WATERMAIN (2+000.0)				
STATION	SURFACE ELEVATION	TWM ELEVATION	COMMENTS	
2+000.0	87.60	85.20	300mmX150mm TEE	
2+009.8	87.72	85.32	DMA PER CITY OF OTTAWA DETAIL W3	
2+011.4	87.69	85.29	CROSS ABOVE 250mmØ STM (±1.25m CLEARANCE)	
2+013.2	87.65	85.25	150mmX150mm TEE	
2+014.7	87.60	85.20	CROSS ABOVE 135mmØ SAN (±1.74m CLEARANCE)	
2+015.2	87.59	85.19	CROSS ABOVE 100mmØ STM (±0.94m CLEARANCE)	
2+024.0	87.37	84.97	CROSS BELOW 200mmØ STM (±1.16m CLEARANCE)	
2+033.0	87.53	85.13	CROSS ABOVE 135mmØ SAN (±1.51m CLEARANCE)	
2+036.0	87.41	85.01	45° HORIZONTAL BEND	
2+037.9	87.40	85.00	150mmX150mm TEE	
2+040.1	87.43	85.03	CROSS ABOVE 450mmØ STM (±0.95m CLEARANCE)	
2+047.5	87.40	85.00	CROSS ABOVE 200mmØ SAN (±1.52m CLEARANCE)	
2+048.9	87.39	84.99	CROSS ABOVE 450mmØ STM (±0.71m CLEARANCE)	
2+051.0	87.29	84.89	CROSS ABOVE 200mmØ SAN (±0.34m CLEARANCE)	
2+054.1	87.13	85.20	CROSS ABOVE 750mmØ STM AS PER CITY OF OTTAWA STANDARD W25.2 (±0.25m CLEARANCE)	
2+059.1	86.98	84.58	45° HORIZONTAL BEND	
2+082.0	87.20	84.80	45° HORIZONTAL BEND	
2+083.5	87.39	84.85	150mmX150mm TEE (HYD)	
2+085.1	87.29	84.89	45° HORIZONTAL BEND	
2+090.5	87.37	85.18	CROSS ABOVE 200mmØ SAN AS PER CITY OF OTTAWA STANDARD W25.2 (±0.25 CLEARANCE)	
2+101.6	87.96	85.56	CROSS ABOVE 135mmØ SAN (±0.45 CLEARANCE)	
2+118.1	88.02	85.62	45° HORIZONTAL BEND	
2+121.2	88.07	85.67	CROSS ABOVE 135mmØ SAN(±0.30 CLEARANCE)	
2+125.9	88.00	85.60	45° HORIZONTAL BEND	
2+144.3	87.86	85.46	45° HORIZONTAL BEND	
2+148.9	87.91	85.51	45° HORIZONTAL BEND	
2+153.6	87.85	85.45	CROSS ABOVE 200mmØ SAN (±2.13 CLEARANCE)	
2+159.0	87.68	85.27	CROSS ABOVE 450mmØ STM (±1.26 CLEARANCE)	
2+160.1	87.66	85.26	150mmØ VALVE AND VALVE BOX	
2+162.0	87.65	85.25	150mmX150mm TEE	

PIPE CROSSING TABLE				
CROSSING	LOWER PIPE	HIGHER PIPE	CLEARANCE	
1	375mmØ SAN OBV = 81.48	450mmØ STM INV = 83.14*	±1.67m	
2	450mmØ STM OBV = 83.79*	300mmØ WTM INV = 84.90	±1.11m	
3	200mmØ SAN OBV = 81.56	300mmØ WTM INV = 84.80	±3.24m	
4	250mmØ STM OBV = 83.89	150mmØ WTM INV = 85.14	±1.25m	
5	450mmØ STM OBV = 83.86*	150mmØ WTM INV = 85.12	±1.26m	
6	200mmØ SAN OBV = 83.17	150mmØ WTM INV = 85.30	±2.13m	
7	150mmØ WTM OBV = 84.97	200mmØ STM INV = 86.13	±1.16m	
8	450mmØ STM OBV = 83.93*	150mmØ WTM INV = 84.88	±0.95m	
9	250mmØ STM OBV = 83.91	150mmØ WTM INV = 84.61	±0.70m	
10	200mmØ SAN OBV = 83.69	150mmØ WTM INV = 84.56	±0.87m	
11	750mmØ STM OBV = 84.82*	150mmØ WTM INV = 85.07	±0.25m	
12	200mmØ SAN OBV = 83.33	150mmØ WTM INV = 84.85	±1.52m	
13	200mmØ SAN OBV = 83.33	450mmØ STM INV = 83.50*	±0.17m	
14	450mmØ STM OBV = 84.13	150mmØ WTM INV = 84.84	±0.71m	
15	200mmØ SAN OBV = 84.40	150mmØ WTM INV = 84.74	±0.34m	
16	750mmØ STM OBV = 84.50*	150mmØ WTM INV = 85.05	±0.25m	
17	250mmØ STM OBV = 84.09	200mmØ SAN INV = 84.33	±0.24m	
18	200mmØ SAN OBV = 84.78	150mmØ WTM INV = 85.03	±0.25m	
19	200mmØ SAN OBV = 83.69	250mmØ STM INV = 83.89	±0.20m	
20	200mmØ SAN OBV = 83.83	150mmØ WTM INV = 84.08	±0.25m	
21	200mmØ SAN OBV = 83.56	300mmØ WTM INV = 84.41	±0.85m	
22	750mmØ STM OBV = 85.12*	150mmØ WTM INV = 85.37	±0.25m	
23	200mmØ SAN OBV = 83.69	750mmØ STM INV = 84.13	±0.44m	
24	200mmØ SAN OBV = 84.32	150mmØ WTM INV = 84.57	±0.25m	

* INV/OBV INDICATED FOR CONCRETE PIPES ARE OUTER DIAMETER

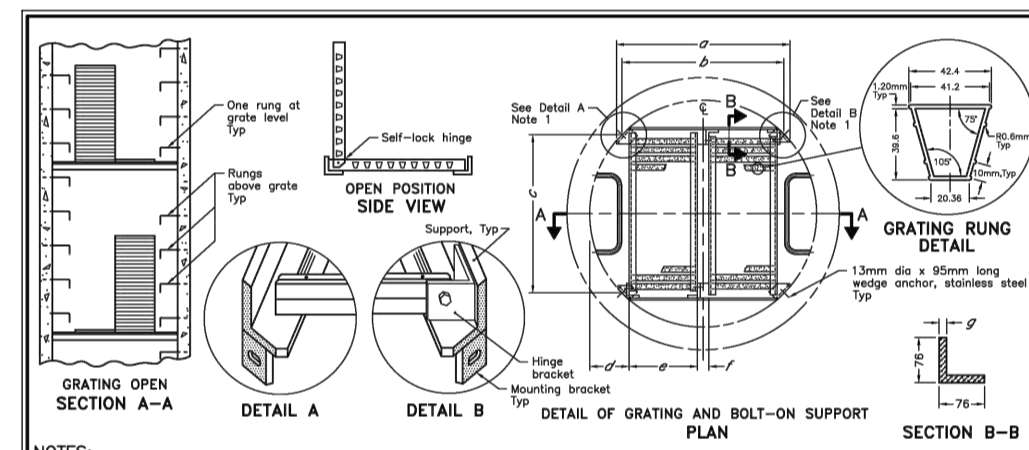

ONTARIO PROVINCIAL STANDARD DRAWING Nov 2018 **Rev 1**

ALUMINIUM SAFETY PLATFORM FOR CIRCULAR MAINTENANCE HOLES

OPSD 404.020

MH Diameter (No. of Grates)	Ø 1200	Ø 900	Ø 800	Ø 700	Ø 600	Ø 500	Ø 400			
A	1200	2	800	2	1136	1278	1293	358	65	12
B	1800	3	1344	1293	1293	358	380	65	12	
C	2400	4	1724	1724	1294	401	380	65	12	