

2475 Regina Street

Site Servicing and Stormwater Management Report



Prepared for:
Windmill Development Group

November 18, 2024

Prepared by:
Stantec Consulting Ltd.

Project/File:
160401689

2475 Regina Street

Revision	Description	Author	Date	Quality Check	Date	Independent Review	Date
0	SPC Submission	Michael W.	2024-03-27	Dustin T.	2024-03-27	Peter M.	2024-03-27
1	Updated Site Plan	Michael W.	2024-11-25	Dustin T.	2024-11-28	Peter M.	2024-11-25



2475 Regina Street

The conclusions in the Report titled 2475 Regina Street are Stantec's professional opinion, as of the time of the Report, and concerning the scope described in the Report. The opinions in the document are based on conditions and information existing at the time the scope of work was conducted and do not take into account any subsequent changes. The Report relates solely to the specific project for which Stantec was retained and the stated purpose for which the Report was prepared. The Report is not to be used or relied on for any variation or extension of the project, or for any other project or purpose, and any unauthorized use or reliance is at the recipient's own risk.

Stantec has assumed all information received from Windmill Development Group (the "Client") and third parties in the preparation of the Report to be correct. While Stantec has exercised a customary level of judgment or due diligence in the use of such information, Stantec assumes no responsibility for the consequences of any error or omission contained therein.

This Report is intended solely for use by the Client in accordance with Stantec's contract with the Client. While the Report may be provided by the Client to applicable authorities having jurisdiction and to other third parties in connection with the project, Stantec disclaims any legal duty based upon warranty, reliance or any other theory to any third party, and will not be liable to such third party for any damages or losses of any kind that may result.



Prepared by

Signature

Michael Wu, E.I.T

Printed Name



Reviewed by

Signature

Dustin Thiffault, P.Eng.

Printed Name



Approved by

Signature

Peter Moroz, P.Eng., MBA

Printed Name



Table of Contents

1	Introduction	1
1.1	Objective	2
2	References	4
3	Potable Water Servicing	5
3.1	Background	5
3.2	Water Demands	5
3.2.1	Domestic Water Demands	5
3.2.2	Fire Flow Demands	6
3.3	Level of Servicing	6
3.3.1	Boundary Conditions	6
3.3.2	Allowable Domestic Pressures	6
3.3.3	Allowable Fire Flow Pressures	7
3.3.4	Fire Hydrant Coverage	7
3.4	Proposed Water Servicing	8
4	Wastewater Servicing	10
4.1	Design Criteria	10
4.2	Wastewater Generation and Servicing Design	10
4.3	Proposed Sanitary Servicing	11
5	Stormwater Management and Servicing	13
5.1	Objectives	13
5.2	SWM Criteria and Constraints	13
5.3	Existing Conditions	14
5.4	Stormwater Management Design	15
5.4.1	SWMM Dual Drainage Methodology	15
5.4.2	Model Input Parameters	16
5.5	Model Results and Discussion	20
5.5.1	Hydrologic Results	20
5.5.2	Quality Control	22
5.6	Runoff Volume Control	23
6	Grading and Drainage	25
7	Utilities	25
8	Approvals and Permits	26
9	Erosion Control During Construction	27
10	Geotechnical Investigation	28
11	Conclusions	30
11.1	Water Servicing	30
11.2	Wastewater Servicing	30
11.3	Stormwater Management and Servicing	30
11.4	Grading	30
11.1	Erosion and Sediment Control During Construction	31
11.2	Utilities	31
11.3	Approvals and Permits	31

List of Tables

Table 1.1: Unit Type Breakdown	2
Table 3.1: Estimated Water Demands	5



Table 3.2: Boundary Conditions6
Table 4.1: Estimated Wastewater Peak Flow11
Table 5.1: Summary of Existing Subcatchment Areas14
Table 5.2: General Subcatchment Parameters16
Table 5.3: Individual Subcatchment Parameters.....17
Table 5.4: Surface Storage Parameters17
Table 5.5: Roof Control Areas19
Table 5.6: Outlet/Orifice Parameters.....19
Table 5.7: Exit Loss Coefficients for Bends at Manholes20
Table 5.8: Outlet/Orifice Parameters.....21
Table 5.9: Maximum Surface Water Depths22
Table 5.10: Quality Control Storage Volumes23
Table 5.11: SWM Facility Drawdown Estimate23
Table 5.12: Runoff Volume Control Storage Volumes.....24
Table 10.1: Recommended Pavement Structure28

List of Figures

Figure 1.1: Key Plan of Site1
Figure 3.1: Existing Fire Hydrant Coverage Map8

List of Appendices

Appendix A Background Information

- A.1 Site Plan
- A.2 Pre-Consultation
- A.3 Correspondence with Architect on Building Construction

Appendix B Water Servicing

- B.1 Domestic Water Demands
- B.2 Fire Flow Demands (2020 FUS)
- B.3 Boundary Conditions

Appendix C Sanitary Servicing

- C.1 Sanitary Design Sheet
- C.2 Correspondence with City on Sanitary Sewer Capacity

Appendix D Stormwater Management

- D.1 Storm Sewer Design Sheet
- D.2 PCSWMM Model Input
- D.3 Excerpts from the SWM Design Criteria for the Pinecrest Creek/Westboro Area (City of Ottawa, May 2020)

Appendix E Background Reports



1 Introduction

Stantec Consulting Ltd. has been commissioned by Windmill Development Group to prepare the following Site Servicing and Stormwater Management (SWM) report in support of a Site Plan Control (SPC) application for the proposed development located at 2475 Regina Street in the City of Ottawa

The 1.04 ha site is situated at the east end of Regina Street and has undergone zoning by-law amendment to R5C and comprises of an existing one-storey long term care home operated by Parkway House with surface parking and green open space. The site is bound by the Byron Linear Tramway Park and a former Ottawa Transportation Commission streetcar right-of-way to the north, Lincoln Heights Road, Regina Street, and an existing residential development to the west, the Kichi Zibi Mikan Parkway and Pincrest Creek to the east, and Richmond Road to the south, as shown in **Figure 1.1** below.

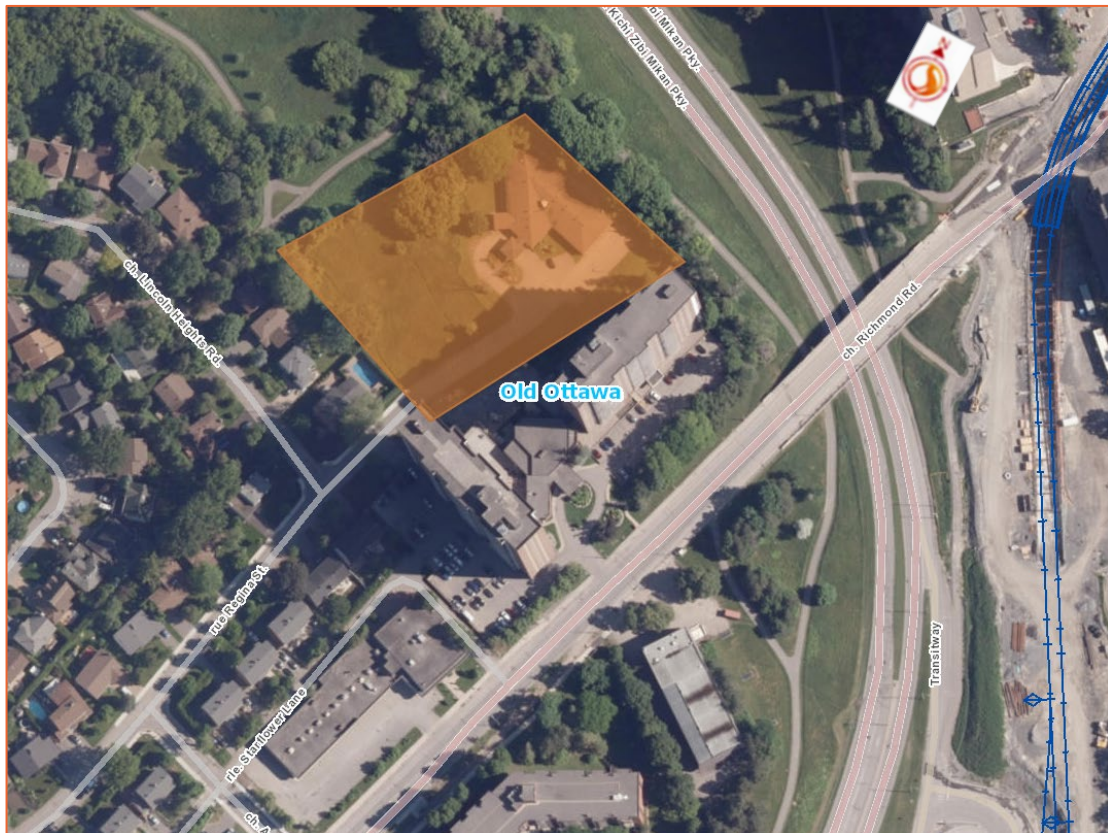

Figure 1.1: Key Plan of Site

The proposed 1.04 ha site will be developed in two phases, with the first phase consisting of a 7-storey apartment building and a 16-storey apartment building, while the second phase will consist of a 28-storey apartment building. Diamond Schmitt Architects has prepared a site plan dated November 7th, 2024, as shown in **Appendix A.1**, while the buildings and unit type breakdown are listed in **Table 1.1** below.



Table 1.1: Unit Type Breakdown

Unit Type	Building A1	Building T1	Building T2	Total
Studio	8	15	-	23
One-bedroom	48	90	170	308
Two-bedroom	12	59	122	193
Three-bedroom	-	15	19	34
LTC Bed	12	-	-	12
Total	80	179	311	577

1.1 Objective

This site servicing and stormwater management (SWM) report presents a servicing scheme that is free of conflicts, provides on-site servicing in accordance with City of Ottawa Design Guidelines, and uses the existing municipal infrastructure in accordance with any limitations communicated during consultation with the City of Ottawa staff. Details of the existing infrastructure located within the Regina Street and Lincoln Heights Road rights of way (ROW) were obtained from available as-built drawings and site topographic survey.

Criteria and constraints provided by the City of Ottawa have been used as a basis for the detailed servicing design of the proposed development. Specific and potential development constraints to be addressed are as follows:

Potable Water Servicing

- Estimate water demands to characterize the feed for the proposed development which will be serviced from the existing 150 mm diameter watermain on Regina Street and/or 203 mm diameter watermain on Lincoln Heights Road.
- Watermain servicing for the development is to be able to provide average day, maximum day, and peak hour demands (i.e., non-emergency conditions) at pressures within the allowable range of 276 to 552 kPa (40 to 80 psi)
- Under fire flow (emergency) conditions with maximum day demands, the water distribution system is to maintain a minimum pressure greater than 140 kPa (20 psi)

Wastewater Servicing

- Estimate wastewater flows generated by the development and size sanitary sewers which will outlet to the existing 375 mm diameter sanitary sewer located on Regina Street and Lincoln Heights Road.

Stormwater Management and Servicing

- Determine the stormwater management storage requirements to meet the allowable release rate based on SWM Guidelines for the Pinecrest Creek / Westboro Study Area.



2475 Regina Street

1 Introduction

- Determine Post development peak 100-year flows and excess stormwater to be detained on-site to meet a 5-year pre-development target release rate.
- Define major and minor conveyance systems in conjunction with the proposed grading plan.
- Define and size the proposed storm services that will be connected to the existing 300 mm diameter municipal storm sewer within the Regina Street ROW.

Prepare a grading plan in accordance with the proposed site plan and existing grades.

Drawing SSP-1 illustrates the proposed internal servicing scheme for the site.



2 References

Documents referenced in preparation of this site servicing and stormwater management report for 2475 Regina Street include:

- *City of Ottawa Design Guidelines – Water Distribution*, City of Ottawa. July 2010 (including all subsequent technical bulletins).
- *City of Ottawa Sewer Design Guidelines (SDG)*, City of Ottawa, October 2012 (including all subsequent technical bulletins).
- *Geotechnical Investigation*, Proposed Mixed-Use Development 2475 Regina Street, Ottawa, Ontario, Prepared for Parkway House Development Fund LP by Paterson Group, August 2021.
- *Stormwater Management Guidelines for the Pinecrest Creek/Westboro Area Final Report*, Prepared for Planning and Infrastructure, City of Ottawa by J.F. Sabourin and Associates Inc., May 2019.
- *Stormwater Management Design Criteria for the Pinecrest Creek/Westboro Area*, City of Ottawa, May 2020.
- *Water Supply for Public Fire Protection*, Fire Underwriters Survey, 2020.
- *2475 Regina Street – Adequacy of Services Report*, Stantec Consulting Ltd., Revision 2, January 26, 2023



3 Potable Water Servicing

3.1 Background

The proposed development is located within Pressure Zone 1W of the City of Ottawa’s Water Distribution System. The existing Parkway House maintains a water service lateral connection to the existing 150 mm diameter watermain on Regina Street with an existing fire hydrant on site. The existing services will be blanked at the main by City forces while the existing hydrant will be disposed of off site, as shown in the Existing Conditions and Removals Plan (see **Drawing EX-1**).

3.2 Water Demands

3.2.1 Domestic Water Demands

The City of Ottawa Water Distribution Guidelines (July 2010) and ISTB 2021-03 Technical Bulletin were used to determine water demands based on projected population densities for residential areas and associated peaking factors. The population was estimated using an occupancy of 1.0 persons per unit for the long-term care units, 1.4 persons per unit for studio and one-bedroom apartments, 2.1 persons per unit for two-bedroom apartments, and 3.1 persons per unit for three-bedroom apartments. Based on the unit type breakdown in **Table 1.1**, the proposed building is estimated to have a total population of 996 persons.

A daily rate of 280 L/cap/day has been used to estimate average daily (AVDY) potable water demand for the residential units, and 400 L/cap/day for the long-term care units. Maximum day (MXDY) demands were determined by multiplying the AVDY demands by a factor of 2.5 for residential areas and 1.5 for commercial areas and long-term care units. Peak hourly (PKHR) demands were determined by multiplying the MXDY by a factor of 2.2 for residential areas and 1.8 for commercial areas and long-term care units. The estimated demands for each tower are summarized in **Table 3.1** below and detailed in **Appendix B.1**.

Table 3.1: Estimated Water Demands

Phase	Building	No. of Units	Population	AVDY (L/s)	MXDY (L/s)	PKHR (L/s)
1	Parkway House (A1)	87	130	0.44	1.04	2.26
	West Tower (T1)	179	318	1.03	2.57	5.66
	Total	266	448	1.47	3.61	7.92
2	East Tower (T2)	311	553	1.79	4.48	9.86
Total Site		577	996	3.3	8.1	17.8



3.2.2 Fire Flow Demands

Fire flow requirements were estimated using Fire Underwriters Survey (FUS) methodology. The FUS estimate is based on a building of non-combustible construction type with two-hour fire rated structural members, equipped with full protections of all vertical openings. As a result, the 'gross construction area' of the largest floor (floors with the largest footprint, 1378 m²) + 25 % of the gross construction area of two additional floors immediately above them was used for the purpose of the FUS calculation, as per page 22 of the *Fire Underwriters Survey's Water Supply for Public Fire Protection, 2020*.

Additionally, it is anticipated that the building will be equipped with an automatic sprinkler system that is fully supervised and conforms to the NFPA 13 standard. The 7-storey Parkway House was determined to have the largest fire flow demand at approximately 4,000 L/min (66.7 L/s). Detailed fire flow calculations per the FUS methodology are provided in **Appendix B.2**, while confirmation of construction type is provided in **Appendix A.3**.

3.3 Level of Servicing

3.3.1 Boundary Conditions

The estimated domestic water and fire flow demands were used to define the level of servicing required for the proposed development from the municipal watermain and hydrants within the Regina Street ROW. The boundary conditions provided by the City of Ottawa on March 22, 2024 (see **Appendix B.3**). Note that the boundary conditions were requested with a fire flow demand of 167 L/s (10,000 L/min) for a conservative estimate of the hydraulic grade line (HGL) under worst-case fire flow scenario.

Table 3.2: Boundary Conditions

	Regina Street	Lincoln Heights Road
Min. HGL (m)		108.3
Max. HGL (m)		115.8
Max. Day + Fire Flow (167 L/s) (m)	86.6	93.8

3.3.2 Allowable Domestic Pressures

The desired normal operating pressure range in occupied areas as per the City of Ottawa 2010 Water Distribution Design Guidelines is 345 kPa to 552 kPa (50 psi to 80 psi) under a condition of maximum daily flow and no less than 276 kPa (40 psi) under a condition of maximum hourly demand. Furthermore, the maximum pressure at any point in the water distribution should not exceed 689 kPa (100 psi) as per the Ontario Building/Plumbing Code; pressure reducing measures are required to service areas where pressures greater than 552 kPa (80 psi) are anticipated in occupied areas.

The proposed finished floor elevation of the first floor, 65.5 m, will serve as the ground floor elevation for the calculation of the residual pressures at ground level. As per the boundary conditions, the on-site pressures



are expected to range from 420 to 493 kPa (60.8 to 71.5 psi) under normal operating conditions, which are within the normal operating pressure range defined by the City of Ottawa design guidelines as within 276 kPa to 552 kPa (40 psi to 80 psi). It is anticipated that booster pumps will be required to service the upper floors of the buildings.

3.3.3 Allowable Fire Flow Pressures

The boundary conditions provided by the City of Ottawa indicate that the watermain within Regina Street is expected to maintain a residual pressure of 21.1 m equivalent to 207 kPa (30 psi) under the worst-case fire flow conditions. This demonstrates that the watermains and nearby hydrants can provide the required fire flows while maintaining a residual pressure of 20 psi.

3.3.4 Fire Hydrant Coverage

Each of the buildings will be sprinklered and provided with a Siamese (fire department) connection to the right of the main entrance. There are two existing hydrants in the proximity of the proposed development site, as shown in **Figure 3.1**. While the distance of both hydrants from the proposed development are less than 76 m, HYD-02 is not within 45 metres from the closest Siamese connection per the OBC requirements, while HYD-01 is located within the proposed private roadway and would therefore be removed and disposed for the development.

According to the NFPA 1 Table 18.5.4.3 in Appendix I of the City of Ottawa Technical Bulletin ISTB-2018-02, a hydrant situated less than 76 m away from a building can supply a maximum capacity of 5,678 L/min, while a hydrant situated between 76 m and 152 m away from a building can supply a maximum capacity of 3,785 L/min.

To meet requirements of Section 3.2.5.16(1) of the Ontario Building Code (OBC), two new fire hydrants are proposed within the site, with the west hydrant located at the parking area for the Parkway House and the east hydrant located along the south side of Regina Street between Towers T1 and T2. Both proposed hydrants are within 45 metres from the Siamese connections, as shown on **Drawing SSP-2**.





Figure 3.1: Existing Fire Hydrant Coverage Map

3.4 Proposed Water Servicing

The existing 150 mm diameter watermain on site from Regina Street will be upsized to 200 mm and realigned, while a new 200 mm diameter connection to the existing 200 mm diameter watermain on Lincoln Heights Road at the Byron Linear Tramway Park pathway crossing is proposed at the north for redundancy and looping. Windmill Development is in the process of securing the easement through the park for the proposed watermain with the City. A 200mm main isolation valve separating the two connections is proposed in the Lincoln Heights Road watermain. The sizing of the service connections to each building is to be confirmed by the mechanical consultant.

The proposed water servicing is shown in the attached drawing set, with **Drawing SSP-1** showcasing the Phase 1 interim servicing scheme, in which a temporary 200 mm diameter water service is installed to allow for servicing to the existing Parkway House building during construction, and **Drawing SSP-2** showcasing



2475 Regina Street
3 Potable Water Servicing

the servicing scheme for the ultimate buildout, where the 200mm diameter service lateral is truncated at the underground parking garage following construction of Tower T2.

Based on the City of Ottawa Water Design Guidelines and the provided boundary conditions, the existing 200 mm diameter watermain on Regina Street and Lincoln Heights Road can provide adequate fire and domestic flows for the subject site.

Booster pumps are required for the building. The mechanical consultant or plumbing contractor will ultimately be responsible to size the service laterals and confirm building pressures are adequate to meet building code requirements. The location of the water services within the property area will be coordinated with the building's architect to accommodate the underground parking structure on Level P1 and P2.



4 Wastewater Servicing

The development will be serviced from the existing 375 mm diameter concrete sanitary sewer within Regina Street and Lincoln Heights Road. The existing 200 mm diameter sanitary sewer within Regina Street east of the existing manhole at the intersection with Lincoln Heights Road is proposed to be removed and replaced at an increased size and reduced slope to facilitate gravity connection for the proposed development as shown in **Drawing EX-1**.

4.1 Design Criteria

As outlined in the City of Ottawa Sewer Design Guidelines and the MECP Design Guidelines for Sewage Works, the following criteria were used to calculate the estimated wastewater flow rates and to determine the size and location of the sanitary service lateral:

- Minimum velocity = 0.6 m/s (0.8 m/s for upstream sections)
- Maximum velocity = 3.0 m/s
- Manning roughness coefficient for all smooth wall pipes = 0.013
- Minimum size of sanitary sewer service = 135 mm
- Minimum grade of sanitary sewer service = 1.0 % (2.0 % preferred)
- Average wastewater generation = 280 L/person/day (per City Design Guidelines)
- Peak Factor = based on Harmon Equation; maximum of 4.0 (residential)
- Harmon correction factor = 0.8
- Infiltration allowance = 0.33 L/s/ha (per City Design Guidelines)
- Minimum cover for sewer service connections – 2.0 m
- Population density for long-term care unit – 1.0 persons/unit
- Population density for one-bedroom and studio apartments – 1.4 persons/apartment
- Population density for two-bedroom apartments – 2.1 persons/apartment
- Population density for three-bedroom apartments – 3.1 persons/apartment

4.2 Wastewater Generation and Servicing Design

The estimated peak wastewater flows generated are based on the current site plan and unit breakdown as shown in **Table 1.1**. The anticipated wastewater peak flow generated from the proposed development is summarized in **Table 4.1** below and detailed in **Appendix C.1**.



Table 4.1: Estimated Wastewater Peak Flow

Residential Units				Institutional Areas			Infiltration Flow (L/s)	Total Peak Flow (L/s)
Number of Units	Population	Peak Factor	Peak Flow (L/s)	Area (ha)	Peak Factor	Peak Flow (L/s)		
577	996	3.04	9.9	0.14	1.5	0.1	0.3	10.3

- Average residential sanitary flow = 280 L/p/day and design institutional flow based on 28,000 L/ha/day per City of Ottawa Sewer Design Guidelines
- Peak factor for residential units calculated using Harmon's formula, using a Harmon correction factor of 0.8.
- Apartment population estimated based on 1.4 persons/unit for studio and one-bedroom apartments, 2.1 persons/unit for two-bedroom apartments, and 3.1 persons/unit for three-bedroom apartments.
- Infiltration flow = 0.33 L/s/ha

An updated memo addressing the capacity requirements for the Lincoln Heights Pumps station reflecting the observed wet weather flows of 44l/s within the station was prepared and submitted to the City on June 6, 2024. Per our recommendations, the new pumps being installed under the current facility upgrade (City Contract No. CP000546) are able to meet and exceed the required flow of 55l/s to accommodate the wet weather flow (44l/s) plus that from the proposed development noted above. No additional physical upgrades are anticipated to accommodate the Regina Street development based on the information available under the current construction project at Lincoln Heights Pumping Station.

4.3 Proposed Sanitary Servicing

The site is proposed to be serviced by an onsite sanitary sewer network comprising of two 300 mm diameter sanitary sewer laterals to effectively convey wastewater flows from the proposed buildings to the existing manhole on Regina Street (MHSA25242) as shown in **Drawings SA-1 and SSP-2**. Final sizing of the laterals is to be confirmed by the mechanical consultant. Full port backwater valves are to be installed on all sewer services within the site to prevent any surcharge from the downstream sewer from impacting the proposed development and will be coordinated with the building mechanical consultant.

The phasing of the sanitary servicing is shown in the attached drawing set, with **Drawing SSP-1** showcasing the Phase 1 servicing scheme, in which a temporary 125 mm diameter service lateral (to match existing site conditions) is installed to allow for servicing to the existing Parkway House building during construction, and **Drawing SSP-2** showcasing the servicing scheme for the ultimate buildout, where the service lateral is truncated at the underground parking garage following construction of Tower T2.

The proposed sanitary laterals for the buildings will be installed to provide a gravity outlet for the basement level and all floors above grade. See **Drawing SSP-2** for further details of the sewer connections. Furthermore, floor drains will be installed in the parking garage to collect wastewater and convey it to the building's sanitary service laterals. A monitoring manhole (SAN 1) has been provided at the most downstream connection to sewers within Regina Street. The location and layout of the sanitary network



2475 Regina Street
4 Wastewater Servicing

within the proposed parking structure internal to the proposed building will be coordinated with the mechanical and structural engineer.



5 Stormwater Management and Servicing

5.1 Objectives

The goal of this stormwater servicing and stormwater management (SWM) plan is to determine the measures necessary to control the quantity and quality of stormwater released from the proposed development to meet the criteria established during the consultation process with City of Ottawa and to provide sufficient details required for site plan control approval.

5.2 SWM Criteria and Constraints

Criteria were established by combining current design practices outlined by the City of Ottawa Design Guidelines (OSDG, October 2012, as amended), through consultation with City of Ottawa staff, and referencing the Stormwater Management Design Criteria for the Pinecrest Creek/Westboro Area (PWDC). The following summarizes the criteria, with the source of each criterion indicated in brackets:

General

- Use of the dual drainage principle (OSDG)
- Wherever feasible and practical, site-level measures should be used to reduce and control the volume and rate of runoff (OSDG)
- Assess impact of 100-year event outlined in the City of Ottawa Sewer Design Guidelines on the major and minor drainage systems (OSDG)

Storm Sewer & Inlet Controls

- Discharge for each storm event to be restricted to a 2-year storm event pre-development rate with a maximum pre-development C coefficient of 0.5 (OSDG, and City of Ottawa pre-consultation)
- Peak flows generated from events greater than the 2-year and including the 100-year storm must be detained on site (OSDG, and City of Ottawa pre-consultation)
- The preferred stormwater system outlet for this site is the 300 mm diameter storm sewer within the Regina Street ROW. (City of Ottawa pre-consultation)
- The foundation drainage system is to be independently connected to sewer main unless being pumped with appropriate back up power, sufficient sized pump, and backflow prevention. (City of Ottawa pre-consultation)
- T_c should be not less than 10 minutes. (OSDG).
- Capture, retain, and infiltrate site runoff resultant from storm events up to and including (at minimum) the 10 mm event. (PWDC)

Surface Storage & Overland Flow

- Building openings to be a minimum of 0.30 m above the 100-year water level (OSDG)
- Maximum depth of flow under either static or dynamic conditions shall be less than 0.35 m (OSDG)



- Provide adequate emergency overflow conveyance off-site with a minimum vertical clearance of 15 cm between the spill elevation and the ground elevation at the building envelope in the proximity of the flow route or ponding area (OSDG)

Quality Control

- Site must provide quality control measures that meet 80 % TSS Removal (PWDC)

5.3 Existing Conditions

The existing site (1.04 ha) consists of an existing one-storey long term care home on the eastern area of the site, an access road and parking lot, and green landscaped areas. The existing building will be removed to allow for the proposed development, as shown in the Existing Conditions and Removals Plan (see **Drawing EX-1**).

Three sub-catchments were delineated in the Existing Conditions Storm Drainage Plan (see **Drawing EXSD-1**) based on the surface types (pervious vs. impervious), as well as the direction of uncontrolled discharge under existing conditions. The EXSD-1 plan was used to establish the overall site pre-development runoff coefficient of C=0.41, as summarized in **Table 5.1** below.

Table 5.1: Summary of Existing Subcatchment Areas

Catchment Areas	C	A (ha)
EX-1	0.22	0.50
EX-2	0.61	0.47
EX-3	0.44	0.07
Total	0.41	1.04

The pre-development release rates for the site have been determined using the rational method and the drainage characteristics identified above. A time of concentration for the pre-development area was first determined using the FAA method. As calculated time of concentrations were determined to be below 10 minutes, the minimum 10-minute T_c was assigned. The peak pre-development flow rates shown have been calculated using the rational method as follows:

$$Q=2.78 (C)(I)(A)$$

Where:

Q – Peak flow rate, L/s

C – Site Runoff Coefficient

I – Rainfall intensity, mm/hr (per City of Ottawa IDF curves)



A – Drainage Area, ha

$$\text{Intensity (mm/hr)} = \frac{732.951}{(10 + 6.199)^{0.810}} = 76.81 \text{ mm/hr}$$

$$Q = 2.78(0.41)(76.81\text{mm/hr})(1.04 \text{ ha}) = \mathbf{91.1 \text{ L/s}}$$

Areas EX-1 and EX-3 have been identified as discharging overland to the adjacent park lands and NCC pathway respectively under existing conditions. Peak runoff from areas EX-1 and EX-3 have been determined to be 54.6L/s and 15.3L/s under the 100-year storm event.

5.4 Stormwater Management Design

A hydrologic/hydraulic model was completed with PCSWMM for the sewers and roadways/parking areas within the proposed development, accounting for the estimated major and minor systems to evaluate the storm sewer infrastructure and ensure release rates meet the previously defined target criteria. The use of PCSWMM for modeling of the site hydrology and hydraulics allowed for an analysis of the system response during various storm events. The following assumptions were applied to the model:

- Hydrologic parameters as per Ottawa Sewer Design Guidelines, including Horton infiltration, Manning's 'n', and depression storage values.
- 3-hour Chicago and 12-hour SCS distributions for 2-year, 5-year, and 100-year storm events were used to evaluate the urban component of the dual drainage (i.e. minor system capture rates, total overland flow depth, hydraulic grade line (HGL), etc.).
- A 10mm, 4-hour Chicago storm was used to evaluate the performance of the proposed stormwater management system for retention per requirements of the PWDC.
- The 'climate change' scenario created by adding 20% of the individual intensity values of the 100-year 3-hour Chicago storm at each specified time step was used as an analytical tool to establish the function of the system under extreme events.

Minor system capture rates within the proposed development were restricted to the 2-year peak runoff rate where surface catch basins with ICDs are identified, and uncontrolled elsewhere.

5.4.1 SWMM Dual Drainage Methodology

The proposed development is modeled in one PCSWMM model as a dual conduit system, where:

- 1) The minor system consists of storm sewers, represented by circular conduits, and manholes, represented by storage nodes;
- 2) The major system consists of overland spills, represented by weirs and irregular conduits using street-shaped cross-sections to represent the assumed overland road network with streets at varying slopes, and catch basins with surface ponding areas, represented by storage nodes.



The two systems are connected by outlet/orifice link objects, which represent inlet control devices (ICDs), that connect storage nodes representing catch basins to storage nodes representing manholes. Subcatchments are linked to the nodes representing catch basins and ponding areas so that generated hydrographs are directed there firstly.

5.4.2 Model Input Parameters

Drawing SD-1 summarizes the discretized subcatchments used in the analysis of the proposed development. All parameters were assigned as per applicable Ottawa Sewer Design Guidelines (OSDG); Ontario Ministry of the Environment, Conservation, and Parks (MECP); and background report requirements.

5.4.2.1 Hydrologic Parameters

Key parameters for the proposed development areas are summarized below, while example input files are provided for the 100-year, 3-hour Chicago storm in **Appendix D** which indicate all other parameters. For all other input files and results of storm scenarios, please examine the electronic model files located on the digital media provided with this report. This analysis was performed using PCSWMM, which is a front-end GUI to the EPA-SWMM engine. Model files can be examined in any program which can read EPA-SWMM files version 5.2.4.

Table 5.2: presents the general subcatchment parameters used for the proposed development.

Table 5.2: General Subcatchment Parameters

Parameter	Value
Infiltration Method	Horton
Max. Infil. Rate (mm/hr)	76.2
Min. Infil. Rate (mm/hr)	13.2
Decay Constant (1/hr)	4.14
N Imperv	0.013
N Perv	0.25
Dstore Imperv (mm)	1.57
Dstore Perv (mm)	4.67
Zero Imperv (%)	0

Table 5.3 presents the individual parameters that vary for each of the proposed subcatchments in the model. Subcatchment width parameters were determined by multiplying each subcatchment's area in hectares by 225 where an appropriate width per the OSDG could not be readily identified (lumped or highly irregular catchments). Subcatchment imperviousness was measured directly from the site plan within AutoCAD considering all paved access, sidewalks, and roof areas as entirely impervious areas, and remaining grassed areas as entirely pervious. Weighted runoff 'C' coefficients were determined for each subcatchment considering impervious areas as C=0.90, and pervious as C=0.20.



Table 5.3: Individual Subcatchment Parameters

Subcatchment ID	Area (ha)	Width (m)	Flow Length (m)	Slope (%)	% Impervious
CB-1	0.098	121.0	8.1	3.0	100.00
CB-2	0.047	33.0	14.2	3.0	85.71
DRN2A	0.049	41.0	11.9	3.0	100.00
DRN2B	0.080	27.0	29.7	3.0	71.43
GRN-1	0.028	6.3	44.4	2.0	14.29
GRN-2	0.065	14.6	44.4	2.0	14.29
GRN-3	0.021	4.8	44.4	2.0	14.29
L102A	0.123	51.0	24.2	3.0	80.00
L103A	0.052	40.0	13.1	3.0	100.00
LID-1	0.116	26.1	44.4	3.0	8.57
LID-2	0.063	39.0	16.1	3.0	42.86
LID-3	0.081	103.0	7.8	3.0	14.29
RAMP	0.009	15.0	6.3	15.0	100.00
ROOF-1	0.054	12.1	44.4	2.0	100.00
ROOF-2A	0.040	9.0	44.4	2.0	100.00
ROOF-2B	0.012	2.7	44.4	2.0	100.00
ROOF-3	0.097	21.9	44.4	2.0	100.00

5.4.2.2 Surface and Subsurface Storage Parameters

Table 5.4 summarizes the storage node parameters used in the model. Storage nodes represent the depth of the proposed catch basin barrel plus an additional depth to represent the maximum allowable surface water ponding depth. Surface storage was estimated based on surface models created in AutoCAD for the proposed grading plan. See **Drawing SD-1** for surface storage depths, areas, and volumes.

Table 5.4: Surface Storage Parameters

Storage Node	Invert Elevation (m)	Rim Elevation (m)	Ponding Depth at Spill (m)	Ponding Area (m ²)	Ponding Volume (m ³)
CB1	63.72	65.50	0.20	220.1	14.7
L102A-S	63.95	65.36	0.31	458.3	47.4
L103A-S	64.03	65.33	0.20	175.0	11.7



2475 Regina Street
 5 Stormwater Management and Servicing

ROOF1-S	100.00	100.15	0.15	429	21.5
ROOF2A-S	100.00	100.15	0.15	319	16.0
ROOF2B-S	100.00	100.15	0.15	97	4.8
ROOF3A-S	100.00	100.15	0.15	779	38.9
LID1A	63.09	63.54	0.35	43	10.0
LID1B	62.58	63.04	0.36	41	9.9
LID1C	62.00	62.35	0.35	96.1	18.2
LID2	64.85	65.35	0.35	40	15.0
LID3	63.1	63.9	0.70	92.8	31.2

Underground storage was required to further control runoff during the 100-year storm event. Two irrigation cisterns (node IRR-TANK and IRR-TANK2 totalling 90m³) have been modeled internally to the building underground parking levels that will receive runoff from building rooftops (both controlled areas as described in sections below and uncontrolled green roofs). The cistern volume will be used for on-site irrigation during periods of low rainfall. The cistern is to maintain an overflow pipe discharging to the main building storm service connection.

The building storm service receives captured runoff from uncontrolled surface area drains, the irrigation tank overflow, as well as a surface inlet in area LID-3 to manage water elevations within surface storage in the southeast corner of the site. It is assumed that due to the elevation of the receiving storm sewer that the building storm sewer will be discharged via pump internal to the proposed building. This discharge along with runoff captured by catch basins in the parking lot external to the building is in turn routed to a subsurface storage unit composed of StormTech SC-310 chambers. The StormTech unit has been sized to provide at minimum 75m³ of storage above the invert of the facility (top of the clear stone bedding layer). Outflow from the unit is restricted by a single ICD as well as an overflow weir to permit the system to discharge should the orifice become blocked.

A standing water elevation corresponding to the invert of the facility has been applied to the PCSWMM model for the 2,5, and 100 year events for conservatism, assuming that the water stored below the invert of the unit has not had time to exfiltrate prior to a significant storm event. The clear stone bedding layer is used for quality control and outflow volume reduction to meet SWM targets as described in sections below.

Table 5-6 presents the parameters for orifice and outlet link objects in the model, which represent ICDs and restricted roof release drains respectively. The 300mm circular orifice was assigned a discharge coefficient of 0.61, whereas ICDs representing IPEX Tempest HF controls were assigned a discharge coefficient of 0.572 to match manufacturer discharge curves. The 300mm circular orifice and overflow weir are placed within a manhole structure at the outlet of the proposed StormTech facility. An outlet with capture curve defined by the inlet capacity of a catch basin grate per City standard drawing S30 has been applied to the major system relief for area LID3. Green Roofs are not flow controlled, and instead discharge directly to the building cistern.



Spillway weirs have been modeled to connect surface storage within LID-1, LID-2, and LID-3 to allow inflows exceeding capacity of the surface storage areas to spill based on overland flow routes described on **Drawing GP-1**.

The roof release discharge curves assume the use of standard Watts Model R1100 Accutrol controlled release roof drains as noted in the calculation sheets included in **Appendix D**. Details for the IPEX ICDs and Watts drains are included as part of **Appendix D**. Watts Drainage “Accutrol” roof drain weir data has been used to calculate a practical roof release rate and detention storage volume for the rooftops. It should be noted that the “Accutrol” weir has been used as an example only, and that other products may be specified for use, provided that the total roof drain release rate is restricted to match the maximum rate of release indicated in **Table 5.5**, and that sufficient roof storage is provided to meet (or exceed) the resulting volume of detained stormwater.

Table 5.5: Roof Control Areas

Roof ID	Accutrol Weir Setting	# of Drains	100-yr Release Rate (L/s)	100-yr Storage Required (cu.m)
ROOF-1	Closed	11	6.9	13.1
ROOF-2A	Closed	5	3.2	12.7
ROOF-2B	Closed	3	1.9	2.6
ROOF-3	25% Open	7	6.4	33.4

Table 5.6: Outlet/Orifice Parameters

Name	Inlet	Outlet	Inlet Elev.	Type	Diameter (m)
OR1	CB1	103	63.72	IPEX Tempest HF	0.095*
L102A-O	L102A-S	102	63.95	IPEX Tempest HF	0.108
L103A-O	L103A-S	102	64.03	IPEX Tempest HF	0.083
TANK—100	TANK	100	63.50	CIRCULAR ORIFICE	0.300
LID3A-O	LID3A	103	65.05	S30 GRATE	-
ROOF1-O	ROOF1-S	IRR-TANK	100.00	ROOF CONTROL	-
ROOF2A-O	ROOF2-S	IRR-TANK	100.00	ROOF CONTROL	-
ROOF2B-O	ROOF2A-S	IRR-TANK	100.00	ROOF CONTROL	-
ROOF3-O	ROOF3-S	IRR-TANK	100.00	ROOF CONTROL	-

*Note: CB1 discharge is pumped through building internal plumbing to site storm sewer.



5.4.2.3 Hydraulic Parameters

As per the October 2012 City of Ottawa Sewer Design Guidelines, Manning's roughness values of 0.013 were used for sewer modeling and overland flow corridors representing roadways. Flow over grassed areas were modeled using a Manning's roughness value of 0.25. The storm sewers within the proposed development were modeled to estimate flow capacities and hydraulic grade lines (HGLs) in the proposed condition. The proposed storm sewer design sheet is included in **Appendix D**.

Exit losses at manholes were set for all pipe segments based on the flow angle through the structure. Exit losses were assigned as per City guidelines (Appendix 6b of the guidelines), see **Table 5.7** below.

Table 5.7: Exit Loss Coefficients for Bends at Manholes

Degrees	Coefficient
11	0.060
22	0.140
30	0.210
45	0.390
60	0.640
90	1.320
180	0.020

The proposed development's storm sewers were sized to convey runoff from a 2-Year storm using rational method calculations. The rational method design sheet can be found in **Appendix D**.

5.5 Model Results and Discussion

The following section summarizes the key hydrologic and hydraulic model results. For detailed model results or inputs please refer to the example input files in **Appendix D** and the PCSWMM model in the enclosed digital files.

5.5.1 Hydrologic Results

The following tables demonstrate the peak outflow from each modeled outfall during the design storm events. A free-flowing outfall condition has been modeled for these events to be conservative with respect to peak site release rates. Outfall EX-STRM denotes peak flow conveyance to the downstream existing sewer system within Regina Street, whereas OF-LID1 and OF-LID2 denote spillage from surface storages to the existing City-owned park and NCC pathway system respectively. No spillage to the park or pathway is anticipated for design events up to and including the 100-year storm event. Spillage to the park/pathway does not exceed the pre-development release rates from the site as defined in sections above for areas EX-1 and EX-3 for events up to and including the 100-year storm.



Table 5.8: Outlet/Orifice Parameters

Event	Location	Peak Discharge Rate (L/s)	Target (L/s)
2-Year Chicago	EX-STRM	37.6	-
	OF-LID1	0	-
	OF-LID2	0	-
	TOTAL	37.6	91.1
5-Year Chicago	EX-STRM	60.9	-
	OF-LID1	0	-
	OF-LID2	0	-
	TOTAL	60.9	91.1
100-Year Chicago	EX-STRM	92.6	-
	OF-LID1	0	-
	OF-LID2	0	-
	TOTAL	92.6*	91.1
100-Year 12 Hour SCS	EX-STRM	48.5	-
	OF-LID1	0.1	-
	OF-LID2	0	-
	TOTAL	85.9	91.1
100-Year Chicago + 20%	EX-STRM	117.0	-
	OF-LID1	5.5	-
	OF-LID2	2.0	-
	TOTAL	124.5	-
100-Year 12 Hour SCS +20%	EX-STRM	130.0	-
	OF-LID1	8.1	-
	OF-LID2	3.9	-
	TOTAL	142.0	-

*Marginal increase over allowable discharge rate represents <2% exceedance based on conservative model practices.

5.5.1.1 Hydraulic Results

The City of Ottawa requires that during major storm events, the maximum hydraulic grade line be kept at least 0.30 m below the underside-of-footing (USF) of any adjacent units connected to the storm sewer



during design storm events. As the proposed building perimeter foundation drain will be pumped to the storm sewer independently of the underground storage tank, HGLs within the subsurface storage unit will not impact building footings. The maximum hydraulic grade line (HGL) of the underground storage unit reaches 64.06m and 64.22m during the 100 year and 100year +20% Chicago storm event. The HGL elevations in both scenarios remain below the proposed surface elevations as the lowest elevation of the connected catch basins within the aboveground parking structure are at 65.01m.

Table 5.9 presents the maximum total surface water depths (static ponding depth + dynamic flow) above the top-of-grate of ICD controlled catch basins within paved roadways for the 100-year design and climate change storm.

Table 5.9: Maximum Surface Water Depths

Storage Node ID	Structure ID	T/G Elevation (m)	100 Year		100 Year + 20%	
			Max HGL (m)	Surface Water Depth (m)	Max HGL (m)	Surface Water Depth (m)
CB1	CB1	65.15	65.26	0.11	65.29	0.14
L102A-S	L102A	64.95	65.11	0.16	65.15	0.20
L103A-S	L103A	65.03	65.16	0.13	65.18	0.15

5.5.2 Quality Control

As per Criteria 2 of Table 1 of the Stormwater Management Design Criteria for the Pinecrest Creek/Westboro Area, stormwater quality control measures for the site, in which stormwater flows discharge directly into the Ottawa River, are required to meet long term removal of 80 % TSS.

Surface storage areas have been provided via grassed areas at the perimeter of the site within areas LID-1 through LID-3. These features are expected to fill without a minor system outlet during lesser rainfall events (2-year storm and below), with captured runoff slowly infiltrated to the surrounding soil during the inter-event period.

The remainder of captured runoff is directed to the subsurface storage (StormTech) unit to be provided with an extended clear stone layer (porosity = 0.4) beneath the storage system. This layer is proposed to be 1.0m in depth, cover a surface area of approximately 332m², and is anticipated to provide approximately 132.8m³ of storage below the outgoing pipe invert to both provide quality control and meet runoff volume control targets noted in sections below. Measured groundwater levels in proximity to the subsurface storage were noted as between elevations 58.35 and 57.47 per the Geotechnical Investigation by Paterson Group, with long term groundwater levels estimated at 4-5m below ground surface. As such, there are no anticipated concerns with impacts to assimilative capacity of the surrounding soil due to groundwater.

Required volumes of storage may be determined through Table 3.2 of the MECP's Stormwater Management Planning and Design Manual for infiltration facilities as noted in the table below:



Table 5.10: Quality Control Storage Volumes

Area ID	SWMP Type	Tributary Area (ha)	Imperviousness	Required Volume (cu.m)	Provided Volume (cu.m)
LID-1	Infiltration	0.116	8.6%	1.9	38.1
LID-3	Infiltration	0.081	14.3%	1.5	31.2
LID-2	Infiltration	0.063	42.9%	1.7	15.0
ROOF1-3, GRN1-3, RAMP, DRN, CSTRN	Infiltration – Subsurface Storage	0.776	80.4%	29.7	132.8

Equation 4.3 within the MECP’s Stormwater Management Planning and Design Manual has been used to conservatively assess expected facility drawdown times based on a highly conservative soils percolation rate of 10mm/hr. Per the **Table** below, expected facility drawdown times lie in the range of 21-44 hours.

Table 5.11: SWM Facility Drawdown Estimate

Area ID	Volume (cu.m)	Bottom Area (m2)	Percolation Rate (mm/hr)	Drawdown Time (hrs)
LID-1	1.9	36 (14+14+8)	10	13.2
LID-3	1.5	11	10	34.1
LID-2	1.7	19	10	22.4
ROOF1-3, GRN1-3, RAMP, DRN, CSTRN	29.7	332	10	22.4

5.6 Runoff Volume Control

The Stormwater Management Design Criteria for the Pinecrest Creek/Westboro Area outlines a requirement for capture, retention, and infiltration of all site runoff for all storm events up to and including the 10 mm storm event. Runoff volume reduction is anticipated to be provided by intensive green roof areas for some rooftop catchments (areas GRN1-3), via perimeter surface storage provided without minor system outlet for limited drainage areas (LID1-3), and via subsurface storage and infiltration within the southwestern StormTech unit.

Runoff volume control storage requirements have been estimated based on full capture of 10mm of runoff from impervious areas as identified below:



Table 5.12: Runoff Volume Control Storage Volumes

Area ID	Impervious Area (ha)	Required Volume (cu.m)	Provided Volume (cu.m)
LID-1	0.001	0.1	38.1
LID-2	0.027	2.7	15.0
LID-3	0.012	1.2	31.2
ROOF1-3, GRN1-3, RAMP, CB-2, CSTRN	0.624	62.4	132.8

As a further check, the 25mm event noted within the OSDG was used to model the proposed SWM features within PCSWMM. Based on results of the PCSWMM model, no site outflows are noted for the 25mm design storm event, demonstrating adequate storage has been provided onsite to detain runoff from the 10mm event.



6 Grading and Drainage

The proposed re-development site measures approximately 1.04 ha in area. The existing topography across the site is relatively sloped, and currently drains from south to north, with overland flow generally being directed to the edge of the existing multi-use pathway in the Byron Tramway Linear Park.

A detailed grading plan (see **Drawing GP-1**) has been prepared to satisfy the stormwater management requirements, as detailed in **Section 5**, allow for positive drainage away from the face of proposed buildings, and provide for minimum cover requirements for storm and sanitary sewers where possible. Site grading has been established to provide emergency overland flow routes required for stormwater management in accordance with City of Ottawa requirements. No grade raise restriction has been identified for this site.

The subject site is graded to provide an emergency overland flow route to Regina Street and the Byron Linear Tramway Park for storm flows exceeding those generated by the 100-year design storm as per existing conditions.

7 Utilities

Hydro Ottawa has existing utility plant in the area, which will be used to service the site. An overhead (OH) hydro-wire run east-west parallel to Regina Street from Lincoln Heights Road and terminates right at the west property line of the site. The existing utility poles within proximity to the site are to be protected during construction.

As the site is surrounded by existing residential and commercial development, Hydro Ottawa, Bell, Rogers, and Enbridge servicing is readily available through existing infrastructure to service this site. The exact size, location, and routing of utilities will be finalized after design circulation. Existing overhead wires and utility plants may need to be temporarily moved/reconfigured to allow sufficient clearance for the movement of heavy machinery required for construction. The relocation of existing utilities will be coordinated with the individual utility providers upon design circulation.



8 Approvals and Permits

Ontario Ministry of Environment, Conservation and Parks (MECP) Environmental Compliance Approvals (ECAs, formerly Certificates of Approval (CofA)) under the Ontario *Water Resources Act* are not anticipated for the proposed storm and sanitary sewers servicing the proposed site so long as the development remains under singular ownership, to be filed if required at time of severance. Modifications to the sanitary sewer off-site within Regina Street are to be incorporated within the City of Ottawa's CLI-ECA.

For ground or surface water volumes being pumped during the construction phase, typically between 50,000 to 400,000 L/day, it is required to register on the Environmental Activity and Sector Registry (EASR). It is possible that groundwater may be encountered during the foundation excavation on this site. A minimum of two to four weeks should be allotted for completion of the EASR registration and the preparation of the Water Taking and Discharge Plan by a Qualified Person as stipulated under O.Reg. 63/16. An MECP Permit to Take Water (PTTW), which is required for dewatering volumes exceeding 400,000L/day, is not anticipated for the site.



9 Erosion Control During Construction

To protect downstream water quality and prevent sediment build up in catch basins and storm sewers, as well as ensuring no further siltation and erosion of the adjacent National Capital Commission (NCC) lands, during construction, erosion and sediment control measures must be implemented during construction. The following recommendations will be included in the contract documents and communicated to the Contractor.

1. Implement best management practices to provide appropriate protection of the existing and proposed drainage system and the receiving water course(s).
2. Limit the extent of the exposed soils at any given time.
3. Re-vegetate exposed areas as soon as possible.
4. Minimize the area to be cleared and grubbed.
5. Protect exposed slopes with geotextiles, geogrid, or synthetic mulches.
6. Install silt barriers/fencing around the perimeter of the site to prevent the migration of sediment offsite.
7. Install track out control mats (mud mats) at the entrance/egress as shown in **Drawing ECDS-1** to prevent migration of sediment into the public ROW.
8. Provide sediment traps and basins during dewatering works.
9. Install sediment traps (such as SiltSack® by Terrafix) between catch basins and frames.
10. Schedule the construction works at times which avoid flooding due to seasonal rains.

The Contractor will also be required to complete inspections and guarantee the proper performance of their erosion and sediment control measures at least after every rainfall. The inspections are to include:

- Verification that water is not flowing under silt barriers.
- Cleaning and changing the sediment traps placed on catch basins.

Refer to **Drawing ECDS-1** for the proposed location of silt fences, sediment traps, and other erosion control measures.



10 Geotechnical Investigation

A geotechnical investigation report was prepared by Paterson Group on August 18, 2021, to provide an assessment of the subsurface conditions found at the site. Seven (7) boreholes, numbered BH 1-21 to BH 7-21, were advanced to a maximum depth of 17.5 metres below the existing ground surface in the investigation carried out from July 29 to August 3, 2021. The information obtained from the field investigation will guide the design of the site and identify development constraints.

The subsurface profile at the test hole locations consists of a topsoil layer underlain by an approximate 0.8 to 1.8 m thick fill layer. The fill material was generally observed to consist of brown silty sand and/or clay with gravel, cobbles, boulders and varying amounts of topsoil and organics. The fill was observed to be underlain with a hard to very stiff brown silty clay deposit, which was underlain by a glacial till deposit.

Based on available geological mapping, the bedrock consists of Paleozoic shale of the Rockcliffe formation. Bedrock was cored at borehole BH 1-21, where grey quartz sandstone was encountered at 13.8 to 17.5 m BGS and found to be of very poor to fair quality. Based on groundwater level readings obtained from the monitoring wells installed at boreholes BH 1-21, BH 6-21 and BH 7-21 and the meters installed at the remaining boreholes, the long-term groundwater level is anticipated at a depth of approximately 4 to 5 m below ground surface. However, as groundwater levels are subject to seasonal fluctuations, they could vary at the time of construction.

Based on Paterson's recommendations, the site is considered suitable for the proposed development. It is recommended that the proposed high-rise buildings be founded on a raft foundation placed on an undisturbed, compact to dense glacial till bearing surface. Furthermore, it is recommended that the low-rise building and portions of the underground parking levels be supported on a conventional spread footings bearing on undisturbed compact to dense glacial till.

The recommended rigid pavement structure is further presented in **Table 10.1** below.

Table 10.1: Recommended Pavement Structure

Material	Lower Parking Level	Car Only Parking Areas	Access Lanes and Heavy Loading Parking Areas
Exposure Class C2 – 32 MPa Concrete (5 to 8 % Air Entrainment)	125 mm	-	-
Wear Course – HL-3 or Superpave 12.5 Asphaltic Concrete	-	50 mm	40 mm
Wear Course – HL-8 or Superpave 19.0 Asphaltic Concrete	-	-	50 mm
BASE – OPSS Granular A Crushed Stone	300 mm	150 mm	150 mm
SUBBASE – OPSS Granular B Type II	-	300 mm	300 mm



2475 Regina Street
10 Geotechnical Investigation

Refer to the full geotechnical report attached in the submission package for further details.



11 Conclusions

11.1 Water Servicing

Based on the supplied boundary conditions for existing watermains and calculated domestic and fire flow demands for the subject site, the adjacent watermains on Regina Street and Lincoln Heights Road has sufficient capacity to sustain both the required domestic and emergency fire flow demands for the development. Booster pump(s) are required to provide adequate pressures to the towers' upper stories. The proposed development will be serviced by a 200 mm diameter watermain network feeding into the Regina Street and Lincoln Heights Road watermains for looping and redundancy. Two new fire hydrants are proposed on site to provide the needed fire flow demands. Sizing of the water service and requirements for booster pump(s) are to be confirmed by the mechanical consultant.

11.2 Wastewater Servicing

The proposed sanitary sewer servicing for the site will consist of sanitary service laterals, sanitary sump pit, and sump pump(s) directing wastewater through a new 300 mm diameter sanitary sewer on site to the existing 375 mm diameter sanitary sewer on Regina Street and Lincoln Heights Road. The City has confirmed that the Lincoln Heights Pumping Station is scheduled for upgrades, with a target completion date of early 2026, to accept the peak sanitary flows from the proposed development. Existing connections are to be abandoned, and full port backwater valves installed on the proposed sanitary service within the site to prevent any surcharge from the downstream sewer main from impacting the proposed property. A sump pump will be required for sewage discharge from the mechanical room. Sizing of the service lateral, sump pit, and sump pump are to be confirmed by the mechanical consultant.

11.3 Stormwater Management and Servicing

The proposed stormwater management plan follows local and provincial standards. Rooftop storage with controlled roof drains, green roof, and surface/subsurface storage via LID feature located north of the underground parking area has been proposed to limit peak storm sewer inflows to the existing 300 mm diameter storm sewers along Regina Street ROW to the required pre-development levels.

11.4 Grading

Grading for the site has been designed to provide an emergency overland flow route as per City requirements and reflects recommendations in the Geotechnical Investigation Report prepared by Paterson Group Inc. in August 2021. Erosion and sediment control measures will be implemented during construction to reduce the impact on existing facilities.



11.1 Erosion and Sediment Control During Construction

Erosion and sediment control measures and best management practices outlined in this report and included in the drawing set, will be implemented during construction to reduce the impact on adjacent properties, the public ROW, and existing facilities.

11.2 Utilities

Hydro Ottawa has existing utility plant in the area, which will be used to service the site. The detailed design of the required utility services will be further investigated as part of the composite utility planning process, which will follow design circulation for the servicing plans. The relocation of existing utilities in conflict with the proposed development will be coordinated with the individual utility providers as part of the site plan approval process.

11.3 Approvals and Permits

This site may be subjected to the Ministry of the Environment, Conservation and Parks (MECP) Environmental Compliance Approval (ECA) process under O.Reg. 525/98 for modifications to the sanitary sewer within Regina Street. For the expected dewatering needs of 50,000 to 400,000 L/day, the proponent will need to register on the MECP's Environmental Activity and Sector Registry (EASR). A Permit to Take Water, for dewatering needs in excess of 400,000 L/day, is not anticipated for this site.



Appendices



Appendix A Background Information

A.1 Site Plan





A PLANNED ONE PLANET LIVING COMMUNITY WITH GUIDING THEMES OF YEAR-ROUND NATURAL CONNECTIONS, ZERO CARBON LIVING, WELCOMING AND INCLUSIVE COMMUNITY.

No.	Date	Description
1	22-05-13	Issued for ZBA
2	22-10-21	Issued for ZBA Resubmission
4	24-03-08	Issued for Site Plan Control
5	24-03-08	Issued for Schematic Design



A:\work\Draw\211000\Draw\Parkway\2427\100\ARCH\CH\DLT\Building\2427.rvt

1 Site Plan
A010 1:300

Contractor Must Check & Verify all Dimensions on the Job.
Do Not Scale Drawings.
All Drawings, Specifications and Related Documents are the Copyright Property of the Architect and Must be Retained Upon Project Completion or Cancellation of Contract. Distribution and Posting of Documents in Public or Private or Online Without the Written permission of the Architect.
This Drawing is Not to be Used for Construction Until Signed by the Architect.

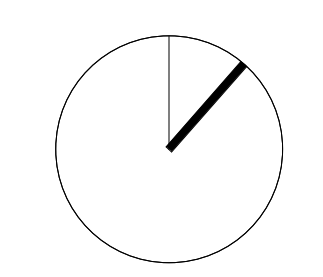

RESIDENTIAL UNIT COUNT

Level	PARKWAY HOUSE(A1)				WEST TOWER (T1)				EAST TOWER (T2)				Sub-Total
	S	1B	2B	3B	S	1B	2B	3B	S	1B	2B	3B	
G						0	0	0		0	0	0	0
2	1	6	4		1	6	3	1		9	6	0	37
3	1	8	5		1	6	4	1		10	6	0	42
4	1	10	2		1	6	4	1		10	6	0	41
5	1	10	2		1	6	4	1		10	6	0	41
6	2	7	3		1	6	4	1		10	6	0	40
7	2	7	3		1	6	4	1		10	6	0	40
8 -MPH					1	6	4	1		9	5	0	26
9					1	6	4	1		7	5	0	24
10					1	6	4	1		5	4	1	22
11					1	6	4	1		5	4	1	22
12					1	6	4	1		5	4	1	22
13					1	6	4	1		5	4	1	22
14					1	6	4	1		5	4	1	22
15					1	6	4	1		5	4	1	22
16					1	6	4	1		5	4	1	22
17 - MPH										5	4	1	10
18										5	4	1	10
19										5	4	1	10
20										5	4	1	10
21										5	4	1	10
22										5	4	1	10
23										5	4	1	10
24										5	4	1	10
25										5	4	1	10
26										5	4	1	10
27										5	4	1	10
28										5	4	1	10
MPH													
Sub-Total	8	48	19	0	15	90	59	15		170	122	19	
Unit Count	75				179				311				565
	11%	64%	25%	0%		50%	33%	8%		55%	39%	6%	

254

311

	Studio	1 BED	2 BED	3 BED
Total Unit	23	308	200	34
	4%	55%	35%	6%

100%

A.2 Pre-Consultation



Wu, Michael

From: Tse, Wendy <Wendy.Tse@ottawa.ca>
Sent: December 10, 2021 14:33
To: 'dschmitt@dsai.ca'; 'jonathan.westeinde@windmilldevelopments.com'; 'ross.farris@windmilldevelopments.com'; 'John Moser'; 'Kirsten Beale'; JF Tessier; Stephen Savell; 'andrew.harte@cghtransportation.com'
Cc: Ren, Jeffrey; Nitsche, Kersten; Surprenant, Eric; Wang, Randolph; McMahon, Patrick
Subject: 2475 Regina-pre-consultation follow-up
Attachments: design_brief_submission requirements_2475 Regina.pdf; files checklist-2475 Regina.pdf

Good afternoon all,

Thank you for meeting with City Staff on Nov. 17 to discuss the redevelopment of 2475 Regina Street. It is our understanding the proposed development features the redevelopment of the Parkway House as a one-storey residential and service facility at the southeast corner of the site, two high-rise apartment towers (18 storeys and 24 storeys) with townhouses at the base, as well as two-storey townhouses bordering the northwest portion of the site. Access to the site is to be provided from Regina Street. Parking to be provided by two levels of a below grade parking garage, with limited surface parking.

The required applications, based on the assumption that the proposal is Official Plan compliant (please see Planning comment below), are the following :

Zoning By-law Amendment (major)-\$21,722.94+\$115 Conservation Authority (CA) fee
Site Plan Control (complex)-\$48,298.80 (Planning and legal)+\$10,000 (based on hard and soft servicing >\$300,000)+\$115 CA fee

Condominium applications may be required depending on the ultimate tenancy.

Note that these are our current fees and the fee applicable at the time of submission will be applied. If the zoning and site plan control applications are submitted concurrently, a 10% discount will be applied.

Our initial comments are the following:

Transportation

1. Follow Traffic Impact Assessment Guidelines
 - Please proceed with scoping.
 - The application will not be deemed complete until the submission of the draft step 1-4, including the functional draft RMA package (if applicable) and/or monitoring report (if applicable). Collaboration and communication between development proponents and City staff are required at the end of every step of the TIA process. An update to the TRANS Trip Generation Manual has been completed (October 2020). This manual (attached) is to be utilized for this TIA.
2. Noise Impact Studies required for the following:
 - Road;
 - Rail; and,
 - Stationary if there will be any exposed mechanical equipment due to the proximity to neighbouring noise sensitive land uses.
3. The site is partially within 600m of future Lincoln Fields LRT Station – therefore TOD mode shares should be targeted. To achieve target mode shares within this zone, we highly recommend the provision of as many TDM measures as possible given the longer walking

distance to the station. The connection to Pinecrest Creek pathway through the NCC will be integral in the achievement of these mode shares.

4. There is no parking/stopping along Regina Street in proximity to the proposed development. Ensure that sufficient visitor and bicycle is provided. Due to these conditions, parking spillover may need to be addressed as part of the TIA.
5. Fire routes cannot be encumbered with parking below.

Site plan comments:

6. On site plan:
 - Show all details of the roads abutting the site up to and including the opposite curb; include such items as pavement markings, accesses and/or sidewalks.
 - Turning templates will be required for all accesses showing the largest vehicle to access the site; required for internal movements and at all access (entering and exiting and going in both directions). Consideration should be given to adding on-site short-term delivery/loading areas.
 - Show all curb radii measurements; ensure that all curb radii are reduced as much as possible
 - Show lane/aisle widths.
7. As the site proposed is residential, AODA legislation applies for all areas accessible to the public (i.e. outdoor pathways, parking, etc.).

Urban Design

1. Design brief required, may be combined with Planning Rationale. The Terms of Reference of the Design Brief is attached for convenience.
 - a. Please note shadow and wind studies are required.
 - b. Please provide multiple views of the proposed development, including the short views from the neighbourhoods and the long views from the parkway.
2. Urban design appreciates the programming and architectural merits of the proposal. However, the proposed development is likely to change to accommodate the required parkland. The following high-level comments are provided based on the current preliminary plan. It is recommended that a second preconsultation be held when a revised preliminary plan is developed.
 - a. Transition – Urban design appreciates using low-rise towns as a buffer between the proposed towers and the adjacent low-rise area. However, it is unclear if the proposed location and height of the towers are appropriate to provide transition to the low-rise area. Please study and demonstrate built form transition strategy of the development. Please review the City’s Urban Design Guidelines for High-Rise Buildings and use 45 degree angular plane as a tool to guide the development of transition strategy.
 - b. Connection –
 - i. Urban design appreciates the intent to connect the site to the NCC pathways and the efforts made so far by the applicant with respect to communications with the NCC. Please continue to study and pursue connections and advance conversations with the NCC. It is crucially important to ensure pedestrian connectivity to the pathway system. The NCC pathways are historically designed and developed for recreation purposes. Recent reports on the media have indicated that a big portion of the pathway system has been at capacity. Should considerations be given to increase the capacity of the pathway system around Lincoln Fields transit station to accommodate commuting foot and bike traffic?
 - ii. The existing sidewalk along Regina must be extended into the site.

- c. Circulation – Urban design has some concerns on internal vehicular circulation with respect to the dead-end streets. The internal circulation has to be functional for services such as emergency, delivery, garbage pick-up, snow removal in addition to drop-offs and loading. Considerations may be given to the design of a loop.

Parks

1. Pursuant to Policy 7.2 and Table 58 of the recently-approved Parks and Recreation Facilities Master Plan, this site is in an area of the city that is under-served for parkland. As such, parkland dedication will be required at the time of Site Plan Control.
 - a. While the parkland dedication will be taken at the time of Site Plan Control, if a stand-alone Zoning By-law Amendment application is submitted, the concept plan must show the parkland dedication at the time of application submission.
2. Based on the density of the site, the parkland dedication will be 10% of the site area (e.g., dedication of 1,035.75 sq.m.)
3. The parkland dedication must be in a location that connects to the existing park (Byron Linear Tramway Park) to the north. The revised development concept must show parkland dedication in a location and configuration on the site that also considers the urban design comments.
4. Lands to be dedicated as parkland cannot be encumbered.
5. Please ensure that the submission includes shadow studies that clearly show the impact on Byron Linear Tramway Park to the north.
6. Please provide further information regarding the setback of the proposed development from the north property line to ensure there are no future impacts for limiting distances, etc. on Byron Linear Tramway Park.

Infrastructure

Water: Boundary Conditions request will be required for this site, Fire Flow requirements through FUS calculations and hydrant coverage will need to be demonstrated.

This site will likely require a second connection for redundancy based on domestic demands and the backbone watermain east of the site is not an option.

The normal operating pressure at the publicly owned watermain (ground elevation) is 57-70psi.

Wastewater: We will need more information as to anticipated wastewater flows. A small lift station exists downstream, and we will require the expected sanitary flows before we can confirm any constraints.

Stormwater Management: Pinecrest Creek Criteria applies to this site. Criteria is as follows:

		over all soft landscaped surfaces.	
Draining to the Ottawa River			
Development subject to Plan of Subdivision or Site Plan Control approval(s) - <u>discharging directly to the Ottawa River</u>			
2	all soil infiltration rates	A minimum on-site retention of the 10 mm design storm; refer to LID references ⁽ⁱ⁾ for guidance on prudent approach to planning infiltration-based LID best management practices. Assumptions re: non-viability of infiltration measures must be substantiated. A green roof, rain harvesting measures and/or a combination of detention/retention measures ⁽ⁱⁱ⁾ could be implemented to provide further runoff volume reduction.	On-site retention of some of the first 10 mm of rainfall by on-site retention measures.
Draining to Pinecrest Creek			
Development subject to Plan of Subdivision or Site Plan Control approval(s) - <u>discharging upstream of the Ottawa River Parkway pipe (ORPP) inlet</u>			
3	all soil infiltration rates	A minimum on-site retention of the 10 mm design storm; refer to LID references ⁽ⁱ⁾ for guidance on prudent approach to planning infiltration-based LID best management practices. Assumptions re: non-viability of infiltration measures must be substantiated. A green roof, rain harvesting measures and/or a combination of detention/retention measures ⁽ⁱⁱ⁾ could be implemented to provide further runoff volume reduction.	On-site retention of some of the first 10 mm of rainfall achieved by on-site retention measures of first 10 mm of rainfall detention of storm ⁽ⁱⁱⁱ⁾ .

Planning

1. The policies of the Council approved new Official Plan are still to be confirmed. The site is within the Inner Urban Transect, with an Evolving Overlay and a Neighbourhood designation. Taken together, it appears this provides for a low rise built form. However, if you have correspondence with Don Herweyer which indicates otherwise, please provide.
2. List of required plans/studies for concurrent as well as separate applications is attached. It would assist in the posting of the reports and plans if they are named as indicated on the list.
3. The Planning Rationale should clearly indicate any zoning relief requested as well as the rationale
4. Note that an archeological study is required as a portion of the site has been identified as having archeological potential.
5. Site plan comments:
 - Section 136 of the Zoning By-law limits the number of townhouse dwellings in a single row to eight.
 - Please show any existing/proposed fencing/buffering on the landscaping plan. Where none currently exist, it should be provided.
 - Please consider improving the internal pedestrian connections. There is an existing sidewalk along the north side of Regina Street which should extend into site, implement an internal walkway system.
 - How will garbage/recycling from the townhome units be handled? Refer to Section 143 of the Zoning By-law.
 - Indicate snow storage areas
 - Please ensure that the zoning provisions related to amenity areas are being met. Refer to Section 137 of Zoning By-law
 - Indicate fire route and location of required 'no parking' signs

As suggested by Urban Design, and taking into account Parks comments, if you would like to meet again once the plans have been amended, please contact me.

Please let me know if there are any questions related to the above.

Thank you.
Wendy

Wendy Tse, MCIP, RPP, LEED GA

Planner III (A)/ Urbaniste III (i)

Development Review /Examen des demandes d'aménagement

Planning, Infrastructure and Economic Development Department/
Services de la planification, de l'infrastructure et du développement économique

City of Ottawa/ Ville d'Ottawa
110, avenue Laurier Avenue West / Ouest, 4th Floor / 4ième étage
Ottawa, ON K1P 1J1

Tel. : 613-580-2424 ext. 12585

E-mail / Courriel : wendy.tse@ottawa.ca

Mail Code: 01-14

'

This e-mail originates from the City of Ottawa e-mail system. Any distribution, use or copying of this e-mail or the information it contains by other than the intended recipient(s) is unauthorized. Thank you.

Le présent courriel a été expédié par le système de courriels de la Ville d'Ottawa. Toute distribution, utilisation ou reproduction du courriel ou des renseignements qui s'y trouvent par une personne autre que son destinataire prévu est interdite. Je vous remercie de votre collaboration.

'

A.3 Correspondence with Architect on Building Construction



Wu, Michael

From: Bennet Hu <BHu@dsai.ca>
Sent: February 29, 2024 16:39
To: Wu, Michael
Cc: Thiffault, Dustin; Moroz, Peter
Subject: Re: Parkway House (2475 Regina Street) Building Construction Type Confirmation

You don't often get email from bh@dsai.ca. [Learn why this is important](#)

Hi Michael,

_The two towers on site will be concrete structures, the 7-storey will be hybrid with concrete structure for ground floor and cores with mass timber structure above.
_All buildings will have rated separation from floor to floor and protection at the vertical openings per NBC.
_All building will be sprinklered.

Hope that helps. Let me know if you have any other questions.

Thanks,
Bennet

From: Wu, Michael <Michael.Wu@stantec.com>
Sent: Thursday, February 29, 2024 3:26 PM
To: Bennet Hu <BHu@dsai.ca>
Cc: Thiffault, Dustin <Dustin.Thiffault@stantec.com>; Moroz, Peter <peter.moroz@stantec.com>
Subject: Parkway House (2475 Regina Street) Building Construction Type Confirmation

Good afternoon, Bennet, hope all is well:

For detailed design phase, I was wondering if you could reconfirm the following information for the proposed buildings at 2475 Regina Street? We would need them for requesting the updated hydraulic boundary conditions from the City.

1. Construction type.
2. Confirmation that the vertical openings (between floors) are going to be **protected** per the fire code requirements outlined in the Ontario and National Building Codes and whether the building will be sprinklered.

Thanks,

Michael Wu EIT
Civil Engineering Intern, Community Development

Direct: 1 (613) 738-6033
Michael.Wu@stantec.com

Stantec
300-1331 Clyde Avenue
Ottawa ON K2C 3G4



The content of this email is the confidential property of Stantec and should not be copied, modified, retransmitted, or used for any purpose except with Stantec's written authorization. If you are not the intended recipient, please delete all copies and notify us immediately.

Appendix B Water Servicing

B.1 Domestic Water Demands



2475 Regina St., Ottawa, ON - Domestic Water Demand Estimates

Site Plan provided by Diamond Schmitt Architects (2024-11-07)

Project No. 160401689

Unit Breakdown updated by Diamond Schmitt Architects (2024-11-21)

Stantec Project No. 160401689 Designed By MW

Revision Date: 22-Nov-2024 Checked By:

Revision: 01 City File No.:

Densities as per City Guidelines:		
Apartment Units		
1 Bedroom	1.4	ppu
2 Bedroom	2.1	ppu
3 Bedroom	3.1	ppu
LTC Units		
1 Bedroom	1.0	ppu



Building ID	No. of Units	Population	Daily Rate of Demand ¹ (L/cap/day or L/ha/day)	Avg Day Demand		Max Day Demand ^{2,3}		Peak Hour Demand ^{2,3}	
				(L/min)	(L/s)	(L/min)	(L/s)	(L/min)	(L/s)
A1									
1 Bedroom	56	78	280	15.2	0.25	38.1	0.64	83.8	1.40
2 Bedroom	19	40	280	7.8	0.13	19.4	0.32	42.7	0.71
3 Bedroom	0	0	280	0.0	0.00	0.0	0.00	0.0	0.00
LTC 1 Bedroom	12	12	400	3.3	0.06	5.0	0.08	9.0	0.15
T1 Apartment Units									
Studio	15	21	280	4.1	0.07	10.2	0.17	22.5	0.37
1 Bedroom	90	126	280	24.5	0.41	61.3	1.02	134.8	2.25
2 Bedroom	59	124	280	24.1	0.40	60.2	1.00	132.5	2.21
3 Bedroom	15	47	280	9.0	0.15	22.6	0.38	49.7	0.83
Total Phase 1:	266	448		88.05	1.47	216.80	3.61	474.96	7.92
T2 Apartment Units									
Studio	0	0	280	0.0	0.00	0.0	0.00	0.0	0.00
1 Bedroom	170	238	280	46.3	0.77	115.7	1.93	254.5	4.24
2 Bedroom	122	256	280	49.8	0.83	124.5	2.08	274.0	4.57
3 Bedroom	19	59	280	11.5	0.19	28.6	0.48	63.0	1.05
Total Phase 2:	311	553		107.55	1.79	268.87	4.48	591.51	9.86
Total Site :	577	996		195.6	3.3	485.7	8.1	1066.5	17.8

¹ Average day water demand for residential areas: 280 L/cap/d

² The City of Ottawa water demand criteria used to estimate peak demand rates for residential areas are as follows:

maximum day demand rate = 2.5 x average day demand rate

peak hour demand rate = 2.2 x maximum day demand rate (as per Technical Bulletin ISD-2010-02)

³ Water demand criteria used to estimate peak demand rates for long-term care units based on commercial areas and are as follows:

maximum daily demand rate = 1.5 x average day demand rate

peak hour demand rate = 1.8 x maximum day demand rate (as per Technical Bulletin ISD-2010-02)

B.2 Fire Flow Demands (2020 FUS)





FUS Fire Flow Calculation Sheet - 2020 FUS Guidelines

Stantec Project #: 160401689
 Project Name: 2475 Regina Street
 Date: 2024-11-27
 Fire Flow Calculation #: 1
 Description: Residential

Notes: 7-storey building with amenities. Information taken from Site plan by Diamond Schmitt Architects dated November 8, 2024.

Step	Task	Notes	Value Used	Req'd Fire Flow (L/min)						
1	Determine Type of Construction	Type II - Noncombustible Construction / Type IV-A - Mass Timber Construction	0.8	-						
2	Determine Effective Floor Area	Sum of Largest Floor + 25% of Two Additional Floors	Vertical Openings Protected?	YES	-					
		1164 1164 1164 1164 1164 1164 1164			1746	-				
3	Determine Required Fire Flow	(F = 220 x C x A ^{1/2}). Round to nearest 1000 L/min	-	7000						
4	Determine Occupancy Charge	Limited Combustible	-15%	5950						
5	Determine Sprinkler Reduction	Conforms to NFPA 13	-30%	-2975						
		Standard Water Supply	-10%							
		Fully Supervised	-10%							
		% Coverage of Sprinkler System	100%							
6	Determine Increase for Exposures (Max. 75%)	Direction	Exposure Distance (m)	Exposed Length (m)	Exposed Height (Stories)	Length-Height Factor (m x stories)	Construction of Adjacent Wall	Firewall / Sprinklered ?	-	-
		North	> 30	0	0	0-20	Type V	NO	0%	833
		East	10.1 to 20	7	7	41-60	Type I-II - Protected Openings	YES	0%	
		South	10.1 to 20	21	7	> 100	Type I-II - Protected Openings	YES	0%	
		West	10.1 to 20	43	2	81-100	Type V	NO	14%	
7	Determine Final Required Fire Flow	Total Required Fire Flow in L/min, Rounded to Nearest 1000L/min							4000	
		Total Required Fire Flow in L/s							66.7	
		Required Duration of Fire Flow (hrs)							1.50	
		Required Volume of Fire Flow (m ³)							360	



FUS Fire Flow Calculation Sheet - 2020 FUS Guidelines

Stantec Project #: 160401689
 Project Name: 2475 Regina Street
 Date: 2024-11-27
 Fire Flow Calculation #: 2
 Description: Residential

Notes: 16-storey building with amenities. Information taken from Site plan by Diamond Schmitt Architects dated November 8, 2024.

Step	Task	Notes	Value Used	Req'd Fire Flow (L/min)						
1	Determine Type of Construction	Type II - Noncombustible Construction / Type IV-A - Mass Timber Construction	0.8	-						
2	Determine Effective Floor Area	Sum of Largest Floor + 25% of Two Additional Floors	Vertical Openings Protected?	YES	-					
		800 800 800 738 800 800 800 800 800	1200	-						
3	Determine Required Fire Flow	(F = 220 x C x A ^{1/2}). Round to nearest 1000 L/min	-	6000						
4	Determine Occupancy Charge	Limited Combustible	-15%	5100						
5	Determine Sprinkler Reduction	Conforms to NFPA 13	-30%	-2550						
		Standard Water Supply	-10%							
		Fully Supervised	-10%							
		% Coverage of Sprinkler System	100%							
6	Determine Increase for Exposures (Max. 75%)	Direction	Exposure Distance (m)	Exposed Length (m)	Exposed Height (Stories)	Length-Height Factor (m x stories)	Construction of Adjacent Wall	Firewall / Sprinklered ?	-	-
		North	10.1 to 20	20	7	> 100	Type I-II - Protected Openings	YES	0%	0
		East	20.1 to 30	42	16	> 100	Type I-II - Protected Openings	YES	0%	
		South	> 30	0	0	0-20	Type V	NO	0%	
		West	> 30	0	0	0-20	Type V	NO	0%	
7	Determine Final Required Fire Flow	Total Required Fire Flow in L/min, Rounded to Nearest 1000L/min							3000	
		Total Required Fire Flow in L/s							50.0	
		Required Duration of Fire Flow (hrs)							1.25	
		Required Volume of Fire Flow (m ³)							225	



FUS Fire Flow Calculation Sheet - 2020 FUS Guidelines

Stantec Project #: 160401689
 Project Name: 2475 Regina Street
 Date: 2024-11-27
 Fire Flow Calculation #: 3
 Description: Residential

Notes: 28-storey building with amenities. Information taken from Site plan by Diamond Schmitt Architects dated November 8, 2024.

Step	Task	Notes	Value Used	Req'd Fire Flow (L/min)						
1	Determine Type of Construction	Type II - Noncombustible Construction / Type IV-A - Mass Timber Construction	0.8	-						
2	Determine Effective Floor Area	Sum of Largest Floor + 25% of Two Additional Floors	Vertical Openings Protected?	YES	-					
		1178 1178 1178 1106 1178 1178 1178 1046 915 784	1767	-	-					
3	Determine Required Fire Flow	(F = 220 x C x A ^{1/2}). Round to nearest 1000 L/min	-	7000						
4	Determine Occupancy Charge	Limited Combustible	-15%	5950						
5	Determine Sprinkler Reduction	Conforms to NFPA 13	-30%	-2975						
		Standard Water Supply	-10%							
		Fully Supervised	-10%							
		% Coverage of Sprinkler System	100%							
6	Determine Increase for Exposures (Max. 75%)	Direction	Exposure Distance (m)	Exposed Length (m)	Exposed Height (Stories)	Length-Height Factor (m x stories)	Construction of Adjacent Wall	Firewall / Sprinklered ?	-	-
		North	> 30	0	0	0-20	Type V	NO	0%	238
		East	> 30	0	0	0-20	Type V	NO	0%	
		South	20.1 to 30	20	17	> 100	Type I-II - Unprotected Openings	NO	4%	
		West	10.1 to 20	7	7	41-60	Type I-II - Protected Openings	YES	0%	
7	Determine Final Required Fire Flow	Total Required Fire Flow in L/min, Rounded to Nearest 1000L/min							3000	
		Total Required Fire Flow in L/s							50.0	
		Required Duration of Fire Flow (hrs)							1.25	
		Required Volume of Fire Flow (m ³)							225	

B.3 Boundary Conditions



Wu, Michael

From: Schaeffer, Gabrielle <gabrielle.schaeffer@Ottawa.ca>
Sent: March 22, 2024 17:08
To: Wu, Michael
Cc: Thiffault, Dustin; Moroz, Peter; Surprenant, Eric; Nehzat Khoshamal, Ali
Subject: RE: 2475 Regina Street - Updated Boundary Conditions Request
Attachments: 2475 Regina Street REVISED March 2024.pdf

You don't often get email from gabrielle.schaeffer@ottawa.ca. [Learn why this is important](#)

Hi Michael,

I have spoken with asset management and operations. I have confirmed that there will be 8 L/s available once the updates to the lift station are completed. The full 10.1 L/s requested cannot be accommodated. My understanding is that the capacity increase will come from contributions made by 2475 Regina Street via a third-party infrastructure agreement with the City, which needs to be coordinated. Operations has indicated the target completion date for the lift station upgrades is early 2026.

Water boundary conditions are below:

The following are boundary conditions, HGL, for hydraulic analysis at 2475 Regina Street (zone 1W) assumed a 203mm looped private network to be connected to the 203 mm watermain on 2475 Regina Street and the 203 mm on Lincoln Heights Road (see attached PDF for location).

Both Connections

Minimum HGL: 108.3 m
Maximum HGL: 115.8 m

Connection 1 (Regina):

Max Day + Fire Flow (166.7 L/s): 86.6 m

Connection 2 (Lincoln Heights):

Max Day + Fire Flow (166.7 L/s): 93.8 m

These are for current conditions and are based on computer model simulation.

Disclaimer: The boundary condition information is based on current operation of the city water distribution system. The computer model simulation is based on the best information available at the time. The operation of the water distribution system can change on a regular basis, resulting in a variation in boundary conditions. The physical properties of watermains deteriorate over time, as such must be assumed in the absence of actual field test data. The variation in physical watermain properties can therefore alter the results of the computer model simulation.

Regards,

Gabrielle (Gabi) Schaeffer, P.Eng
Senior Engineer - Infrastructure Applications

City of Ottawa
Development Review - West Branch
Planning, Real Estate and Economic Development Department
110 Laurier Ave West, 4th Floor East;
Ottawa ON K1P 1J1
Tel: 613-580-2424 x 22517
Cell: 613-227-7419

From: Schaeffer, Gabrielle
Sent: March 19, 2024 11:18 AM
To: Wu, Michael <Michael.Wu@stantec.com>
Cc: Thiffault, Dustin <dustin.thiffault@stantec.com>; Moroz, Peter <peter.moroz@stantec.com>; Surprenant, Eric <Eric.Surprenant@ottawa.ca>; Nehzat Khoshamal, Ali <ali.nehzatkhoshamal@ottawa.ca>
Subject: RE: 2475 Regina Street - Updated Boundary Conditions Request

Hi Michael,

Ali, cc'd, will get back to you on the sanitary capacity question. With respect to the boundary conditions, we expect to receive it back from Infrastructure Planning by mid-next week or earlier.

Regards,
Gabrielle (Gabi) Schaeffer, P.Eng
Senior Engineer - Infrastructure Applications

City of Ottawa
Development Review - West Branch
Planning, Real Estate and Economic Development Department
110 Laurier Ave West, 4th Floor East;
Ottawa ON K1P 1J1
Tel: 613-580-2424 x 22517
Cell: 613-227-7419

From: Wu, Michael <Michael.Wu@stantec.com>
Sent: March 19, 2024 10:38 AM
To: Surprenant, Eric <Eric.Surprenant@ottawa.ca>
Cc: Thiffault, Dustin <dustin.thiffault@stantec.com>; Moroz, Peter <peter.moroz@stantec.com>; Schaeffer, Gabrielle <gabrielle.schaeffer@Ottawa.ca>
Subject: RE: 2475 Regina Street - Updated Boundary Conditions Request

CAUTION: This email originated from an External Sender. Please do not click links or open attachments unless you recognize the source.

ATTENTION : Ce courriel provient d'un expéditeur externe. Ne cliquez sur aucun lien et n'ouvrez pas de pièce jointe, excepté si vous connaissez l'expéditeur.

Good morning, Eric:

As a quick follow-up, is there a timeline on when we can expect the updated boundary conditions and the confirmation on the downstream sanitary sewer capacity?

Thanks,

Michael Wu EIT
Civil Engineering Intern, Community Development

Direct: 1 (613) 738-6033
Michael.Wu@stantec.com

Stantec
300-1331 Clyde Avenue
Ottawa ON K2C 3G4





The content of this email is the confidential property of Stantec and should not be copied, modified, retransmitted, or used for any purpose except with Stantec's written authorization. If you are not the intended recipient, please delete all copies and notify us immediately.

From: Moroz, Peter <peter.moroz@stantec.com>
Sent: Wednesday, March 13, 2024 8:39 AM
To: Schaeffer, Gabrielle <gabrielle.schaeffer@ottawa.ca>; Surprenant, Eric <Eric.Surprenant@ottawa.ca>
Cc: Thiffault, Dustin <Dustin.Thiffault@stantec.com>; Wu, Michael <Michael.Wu@stantec.com>
Subject: RE: 2475 Regina Street - Updated Boundary Conditions Request

Thank you!

Peter

Peter Moroz P.Eng., MBA
Managing Principal, Community Development

Stantec
300 - 1331 Clyde Avenue Ottawa ON K2C 3G4
Cell: (613) 294-2851

peter.moroz@stantec.com

From: Schaeffer, Gabrielle <gabrielle.schaeffer@Ottawa.ca>
Sent: Tuesday, March 12, 2024 4:41 PM
To: Moroz, Peter <peter.moroz@stantec.com>; Surprenant, Eric <Eric.Surprenant@ottawa.ca>
Cc: Thiffault, Dustin <Dustin.Thiffault@stantec.com>; Wu, Michael <Michael.Wu@stantec.com>
Subject: RE: 2475 Regina Street - Updated Boundary Conditions Request

Some people who received this message don't often get email from gabrielle.schaeffer@ottawa.ca. [Learn why this is important](#)

Hi Peter,

I just spoke with Eric. He will be completing your boundary condition request. As for who will be the new PM on the file, I will reassign someone when a submission comes in. If you need to discuss with someone now for a specific reason, let me know.

Thanks,
Gabi

From: Moroz, Peter <peter.moroz@stantec.com>
Sent: March 12, 2024 4:19 PM
To: Surprenant, Eric <Eric.Surprenant@ottawa.ca>
Cc: Thiffault, Dustin <dustin.thiffault@stantec.com>; Wu, Michael <Michael.Wu@stantec.com>; Schaeffer, Gabrielle <gabrielle.schaeffer@Ottawa.ca>
Subject: RE: 2475 Regina Street - Updated Boundary Conditions Request

CAUTION: This email originated from an External Sender. Please do not click links or open attachments unless you recognize the source.

ATTENTION : Ce courriel provient d'un expéditeur externe. Ne cliquez sur aucun lien et n'ouvrez pas de pièce jointe, excepté si vous connaissez l'expéditeur.

Sounds good, thank you.

Peter

Peter Moroz P.Eng., MBA

Managing Principal, Community Development

Stantec
300 - 1331 Clyde Avenue Ottawa ON K2C 3G4
Cell: (613) 294-2851

peter.moroz@stantec.com

From: Surprenant, Eric <Eric.Surprenant@ottawa.ca>
Sent: Tuesday, March 12, 2024 4:18 PM
To: Moroz, Peter <peter.moroz@stantec.com>
Cc: Thiffault, Dustin <Dustin.Thiffault@stantec.com>; Wu, Michael <Michael.Wu@stantec.com>; Schaeffer, Gabrielle <gabrielle.schaeffer@ottawa.ca>
Subject: Re: 2475 Regina Street - Updated Boundary Conditions Request

Hi Peter,
Thanks for this, I am copying Gabrielle on this as she will let you know who will follow up on this.

Thanks,

Eric Surprenant
Sr Project Manager. Infrastructure Projects (T)
Infrastructure & Water Services Dept.
613 580-2424 x27794

Note:

From: Moroz, Peter <peter.moroz@stantec.com>
Sent: March 12, 2024 16:12
To: Surprenant, Eric <Eric.Surprenant@ottawa.ca>
Cc: Thiffault, Dustin <dustin.thiffault@stantec.com>; Wu, Michael <Michael.Wu@stantec.com>
Subject: RE: 2475 Regina Street - Updated Boundary Conditions Request

CAUTION: This email originated from an External Sender. Please do not click links or open attachments unless you recognize the source.

ATTENTION : Ce courriel provient d'un expéditeur externe. Ne cliquez sur aucun lien et n'ouvrez pas de pièce jointe, excepté si vous connaissez l'expéditeur.

Hi Eric, let us know if there is another contact for this project going forward. We assume that it will be you given your previous involvement, but I know there were some recent changes at the City. Let us know.

thx

Peter

Peter Moroz P.Eng., MBA
Managing Principal, Community Development

Stantec
300 - 1331 Clyde Avenue Ottawa ON K2C 3G4
Cell: (613) 294-2851

peter.moroz@stantec.com

From: Wu, Michael <Michael.Wu@stantec.com>
Sent: Tuesday, March 12, 2024 4:07 PM

To: Surprenant, Eric <Eric.Surprenant@ottawa.ca>
Cc: Moroz, Peter <peter.moroz@stantec.com>; Thiffault, Dustin <Dustin.Thiffault@stantec.com>
Subject: RE: 2475 Regina Street - Updated Boundary Conditions Request

Good afternoon, Eric, hope you are well.

Just wanted to do a quick follow-up on the updated boundary condition request for the Parkway House development and when we can expect the updated boundary conditions.

As well, we would like to request confirmation on whether the downstream sanitary sewers on Regina Street and Lincoln Heights Road has the capacity to take in an additional 10.1 L/s of sanitary peak flows from the site.

Attached is the sanitary calculation sheet for your information.

Thanks,

Michael Wu EIT
Civil Engineering Intern, Community Development
Direct: 1 (613) 738-6033
Michael.Wu@stantec.com
Stantec
300-1331 Clyde Avenue
Ottawa ON K2C 3G4



The content of this email is the confidential property of Stantec and should not be copied, modified, retransmitted, or used for any purpose except with Stantec's written authorization. If you are not the intended recipient, please delete all copies and notify us immediately.

From: Wu, Michael
Sent: Friday, March 1, 2024 12:13 PM
To: Surprenant, Eric <Eric.Surprenant@ottawa.ca>
Cc: Moroz, Peter <peter.moroz@stantec.com>; Thiffault, Dustin <Dustin.Thiffault@stantec.com>
Subject: 2475 Regina Street - Updated Boundary Conditions Request

Good afternoon, Eric, hope you are well.

We are requesting updated hydraulic boundary conditions for the proposed Parkway House development at 2475 Regina Street as part of the site plan control application process. The updated site plan will see three blocks of apartment buildings with a total of 567 apartment units and projected to serve 987 residents.

As with our previous boundary condition request, the development would be served by a looped watermain and connected to the existing 203 mm diameter watermains on Regina Street and Lincoln Heights Road.

The updated water demands for the proposed development are as follows:

- Average Day Demand: 3.2 L/s (193 L/min)
- Maximum Day Demand: 8.0 L/s (479.1 L/min)
- Peak Hour Demand: 17.5 L/s (1,051.9 L/min)
- Lower Fire Flow Demand: 66.7 L/s (4,000 L/min)
- Upper Fire Flow Demand for conservative analysis: 166.7 L/s (10,000 L/min)

Attached are the calculation sheets for your reference and location map.

We appreciate your time looking into this for us, and please feel free to reach out to me if you have any more questions or comments.

Best regards,

Michael Wu EIT

Civil Engineering Intern, Community Development

Direct: 1 (613) 738-6033

Michael.Wu@stantec.com

Stantec

300-1331 Clyde Avenue

Ottawa ON K2C 3G4



The content of this email is the confidential property of Stantec and should not be copied, modified, retransmitted, or used for any purpose except with Stantec's written authorization. If you are not the intended recipient, please delete all copies and notify us immediately.

This e-mail originates from the City of Ottawa e-mail system. Any distribution, use or copying of this e-mail or the information it contains by other than the intended recipient(s) is unauthorized. Thank you.

Le présent courriel a été expédié par le système de courriels de la Ville d'Ottawa. Toute distribution, utilisation ou reproduction du courriel ou des renseignements qui s'y trouvent par une personne autre que son destinataire prévu est interdite. Je vous remercie de votre collaboration.

Caution: This email originated from outside of Stantec. Please take extra precaution.

Attention: Ce courriel provient de l'extérieur de Stantec. Veuillez prendre des précautions supplémentaires.

Atención: Este correo electrónico proviene de fuera de Stantec. Por favor, tome precauciones adicionales.

This e-mail originates from the City of Ottawa e-mail system. Any distribution, use or copying of this e-mail or the information it contains by other than the intended recipient(s) is unauthorized. Thank you.

Le présent courriel a été expédié par le système de courriels de la Ville d'Ottawa. Toute distribution, utilisation ou reproduction du courriel ou des renseignements qui s'y trouvent par une personne autre que son destinataire prévu est interdite. Je vous remercie de votre collaboration.

Caution: This email originated from outside of Stantec. Please take extra precaution.

Attention: Ce courriel provient de l'extérieur de Stantec. Veuillez prendre des précautions supplémentaires.

Atención: Este correo electrónico proviene de fuera de Stantec. Por favor, tome precauciones adicionales.

This e-mail originates from the City of Ottawa e-mail system. Any distribution, use or copying of this e-mail or the information it contains by other than the intended recipient(s) is unauthorized. Thank you.

Le présent courriel a été expédié par le système de courriels de la Ville d'Ottawa. Toute distribution, utilisation ou reproduction du courriel ou des renseignements qui s'y trouvent par une personne autre que son destinataire prévu est interdite. Je vous remercie de votre collaboration.

Caution: This email originated from outside of Stantec. Please take extra precaution.

Attention: Ce courriel provient de l'extérieur de Stantec. Veuillez prendre des précautions supplémentaires.

Atención: Este correo electrónico proviene de fuera de Stantec. Por favor, tome precauciones adicionales.

Appendix C Sanitary Servicing

C.1 Sanitary Design Sheet





SUBDIVISION:
2475 Regina Street

DATE: 2024-11-22
REVISION: 1
DESIGNED BY: MW
CHECKED BY:

SANITARY SEWER DESIGN SHEET (City of Ottawa)

FILE NUMBER: 160401689
Ultimate Build-Out

DESIGN PARAMETERS

MAX PEAK FACTOR (RES.)=	4.0	AVG. DAILY FLOW / PERSON	280 l/p/day	MINIMUM VELOCITY	0.60 m/s
MIN PEAK FACTOR (RES.)=	2.0	COMMERCIAL	28,000 l/ha/day	MAXIMUM VELOCITY	3.00 m/s
PEAKING FACTOR (INDUSTRIAL):	2.4	INDUSTRIAL (HEAVY)	55,000 l/ha/day	MANNINGS n	0.013
PEAKING FACTOR (ICI >20%):	1.5	INDUSTRIAL (LIGHT)	35,000 l/ha/day	BEDDING CLASS	B
PERSONS / ONE BEDROOM	1.4	INSTITUTIONAL	28,000 l/ha/day	MINIMUM COVER	2.50 m
PERSONS / 2 BEDROOM	2.1	INFILTRATION	0.33 l/s/ha	HARMON CORRECTION FACTOR	0.8
PERSONS / 3 BEDROOM	3.1	PERSONS - LTC ONE BEDROOM	1.0		

LOCATION			RESIDENTIAL AREA AND POPULATION										COMMERCIAL		INDUSTRIAL (L)		INDUSTRIAL (H)		INSTITUTIONAL		GREEN / UNUSED		C+H	INFILTRATION			TOTAL	PIPE								
AREA ID NUMBER	FROM M.H.	TO M.H.	AREA (ha)	UNITS 1 BEDROOM	2 BEDROOM	3 BEDROOM	LTC 1 BEDROOM	POP.	CUMULATIVE AREA (ha)	POP.	PEAK FACT.	PEAK FLOW (l/s)	AREA (ha)	ACCU. AREA (ha)	AREA (ha)	ACCU. AREA (ha)	AREA (ha)	ACCU. AREA (ha)	AREA (ha)	ACCU. AREA (ha)	AREA (ha)	ACCU. AREA (ha)	PEAK FLOW (l/s)	TOTAL AREA (ha)	ACCU. AREA (ha)	INFILT. FLOW (l/s)	FLOW (l/s)	LENGTH (m)	DIA (mm)	MATERIAL	CLASS	SLOPE (%)	CAP. (FULL) (l/s)	CAP. V PEAK FLOW (%)	VEL. (FULL) (m/s)	
R4A (T2)	SAN 4 SAN 3	SAN 3 SAN 1	0.119	170	122	19		553	0.119	553	3.161	5.7	0.000	0.000	0.000	0.000	0.000	0.000	0.000	0.000	0.000	0.000	0.000	0.0	0.119	0.119	0.04	5.7	50.8	300	PVC	SDR 35	0.22	45.0	12.67%	0.64
								0.119	0.119	553	3.161	5.7	0.000	0.000	0.000	0.000	0.000	0.000	0.000	0.000	0.000	0.000	0.0	0.000	0.119	0.04	5.7	13.7	300	PVC	SDR 35	0.22	45.0	12.67%	0.64	
R2B (T1)	SAN 2	SAN 1	0.078	105	59	15		317	0.078	317	3.254	3.3	0.000	0.000	0.000	0.000	0.000	0.000	0.000	0.000	0.000	0.000	0.0	0.078	0.078	0.03	3.4	14.9	300	PVC	SDR 35	1.00	96.0	3.51%	1.36	
R2A (A1), I2A	SAN 1	EX SAN 1A	0.141	56	19		12	130	0.338	1001	3.040	9.9	0.000	0.000	0.000	0.000	0.000	0.141	0.141	0.697	0.697	0.1	0.838	1.035	0.34	10.3	62.2	300	PVC	SDR 35	0.22	45.0	22.80%	0.64		

C.2 Correspondence with City on Sanitary Sewer Capacity



From: [Schaeffer, Gabrielle](#)
To: [Wu, Michael](#)
Cc: [Thiffault, Dustin](#); [Moroz, Peter](#); [Surprenant, Eric](#); [Nehzat Khoshamal, Ali](#)
Subject: RE: 2475 Regina Street - Updated Boundary Conditions Request
Date: Friday, March 22, 2024 5:09:32 PM
Attachments: [2475 Regina Street REVISED March 2024.pdf](#)

Hi Michael,

I have spoken with asset management and operations. I have confirmed that there will be 8 L/s available once the updates to the lift station are completed. The full 10.1 L/s requested cannot be accommodated. My understanding is that the capacity increase will come from contributions made by 2475 Regina Street via a third-party infrastructure agreement with the City, which needs to be coordinated. Operations has indicated the target completion date for the lift station upgrades is early 2026.

Water boundary conditions are below:

The following are boundary conditions, HGL, for hydraulic analysis at 2475 Regina Street (zone 1W) assumed a 203mm looped private network to be connected to the 203 mm watermain on 2475 Regina Street and the 203 mm on Lincoln Heights Road (see attached PDF for location).

Both Connections

Minimum HGL: 108.3 m

Maximum HGL: 115.8 m

Connection 1 (Regina):

Max Day + Fire Flow (166.7 L/s): 86.6 m

Connection 2 (Lincoln Heights):

Max Day + Fire Flow (166.7 L/s): 93.8 m

These are for current conditions and are based on computer model simulation.

Disclaimer: The boundary condition information is based on current operation of the city water distribution system. The computer model simulation is based on the best information available at the time. The operation of the water distribution system can change on a regular basis, resulting in a variation in boundary conditions. The physical properties of watermains deteriorate over time, as such must be assumed in the absence of actual field test data. The variation in physical watermain properties can therefore alter the results of the computer model simulation.

Regards,

Gabrielle (Gabi) Schaeffer, P.Eng

Senior Engineer - Infrastructure Applications

City of Ottawa

Development Review - West Branch

Planning, Real Estate and Economic Development Department

Appendix D Stormwater Management

D.1 Storm Sewer Design Sheet





2475 Regina Street

**STORM SEWER
DESIGN SHEET**
(City of Ottawa)

DESIGN PARAMETERS

$I = a / (t+b)^c$ (As per City of Ottawa Guidelines, 2012)

	1:2 yr	1:5 yr	1:10 yr	1:100 yr
a =	732.951	998.071	1174.184	1735.688
b =	6.199	6.053	6.014	6.014
c =	0.810	0.814	0.816	0.820

MANNING'S n = 0.013
 BEDDING CLASS = B
 MINIMUM COVER: 2.00 m
 TIME OF ENTRY 10 min

DATE: 2024-11-28
 REVISION: 2
 DESIGNED BY: JP
 CHECKED BY: DT

FILE NUMBER: 160401689

LOCATION			DRAINAGE AREA																	PIPE SELECTION																				
AREA ID NUMBER	FROM M.H.	TO M.H.	AREA (2-YEAR)	AREA (5-YEAR)	AREA (10-YEAR)	AREA (100-YEAR)	AREA (ROOF)	C (2-YEAR)	C (5-YEAR)	C (10-YEAR)	C (100-YEAR)	A x C (2-YEAR)	ACCUM. AxC (2YR)	A x C (5-YEAR)	ACCUM. AxC (5YR)	A x C (10-YEAR)	ACCUM. AxC (10YR)	A x C (100-YEAR)	ACCUM. AxC (100YR)	T of C (min)	I ₂ -YEAR (mm/h)	I ₅ -YEAR (mm/h)	I ₁₀ -YEAR (mm/h)	I ₁₀₀ -YEAR (mm/h)	Q _{CONTROL} (L/s)	ACCUM. Q _{CONTROL} (L/s)	Q _{ACT} (L/s)	LENGTH (m)	PIPE WIDTH OR DIAMETER (mm)	PIPE HEIGHT (mm)	PIPE SHAPE (-)	MATERIAL (-)	CLASS (-)	SLOPE (%)	Q _{CAP} (FULL) (L/s)	% FULL (-)	VEL. (FULL) (m/s)	VEL. (ACT) (m/s)	TIME OF FLOW (min)	
L103A, ROOF, GRN, CB2, DRN2A/B	103	102	0.54	0.00	0.00	0.00	0.00	0.74	0.00	0.00	0.00	0.401	0.401	0.000	0.000	0.000	0.000	0.000	0.000	0.000	10.00	76.81	104.19	122.14	178.56	0.0	0.0	85.5	31.0	450	450	CIRCULAR	CONCRETE	-	0.20	133.0	64.25%	0.81	0.75	0.69
L102A, RAMP, CB-1, LID2	102	101	0.29	0.00	0.00	0.00	0.00	0.32	0.00	0.00	0.00	0.094	0.494	0.000	0.000	0.000	0.000	0.000	0.000	0.000	10.69	74.25	100.68	118.01	172.49	0.0	0.0	102.0	29.1	450	450	CIRCULAR	CONCRETE	-	0.20	133.0	76.66%	0.81	0.79	0.62
	101	TANK	0.00	0.00	0.00	0.00	0.00	0.00	0.00	0.00	0.00	0.000	0.494	0.000	0.000	0.000	0.000	0.000	0.000	0.000	11.31	72.13	97.77	114.57	167.44	0.0	0.0	99.1	8.1	450	450	CIRCULAR	CONCRETE	-	0.20	133.0	74.47%	0.81	0.78	0.17
11.48																																								

Stormwater Management Calculations

Project #160401689, 2475 Regina Street Modified Rational Method Calculations for Storage

2 yr Intensity City of Ottawa	$I = a/(t + b)^c$	a =	732.951	t (min)	I (mm/hr)
		b =	6.199		
		c =	0.81		
				10	76.81
				20	52.03
				30	40.04
				40	32.86
				50	28.04
				60	24.56
				70	21.91
				80	19.83
				90	18.14
				100	16.75
				110	15.57
				120	14.56

2 YEAR Modified Rational Method for Entire Site

Subdrainage Area: ROOF2A
Area (ha): 0.04
C: 0.90
Maximum Storage Depth: 150 mm

tc (min)	I (5 yr) (mm/hr)	Qactual (L/s)	Qrelease (L/s)	Qstored (L/s)	Vstored (m³)	Depth (mm)
5	103.57	10.33	3.15	7.18	2.15	76.5
10	76.81	7.66	3.15	4.51	2.70	81.5
15	61.77	6.16	3.15	3.01	2.71	81.5
20	52.03	5.19	3.15	2.04	2.44	79.1
25	45.17	4.51	3.15	1.35	2.03	75.3
30	40.04	4.00	3.15	0.84	1.51	66.4
35	36.06	3.60	3.15	0.44	0.93	56.1
40	32.86	3.28	3.05	0.23	0.56	48.3
45	30.24	3.02	2.84	0.18	0.49	45.0
50	28.04	2.80	2.66	0.14	0.43	42.1
55	26.17	2.61	2.50	0.11	0.38	39.6
60	24.56	2.45	2.36	0.09	0.33	37.4

Storage: Roof Storage

Depth (mm)	Head (m)	Discharge (L/s)	Vreq (cu. m)	Vavail (cu. m)	Discharge Check	
5-year Water Level	81.53	0.08	3.15	2.71	15.95	-0.15

Subdrainage Area: ROOF1
Area (ha): 0.05
C: 0.90
Maximum Storage Depth: 150 mm

tc (min)	I (5 yr) (mm/hr)	Qactual (L/s)	Qrelease (L/s)	Qstored (L/s)	Vstored (m³)	Depth (mm)
5	103.57	13.90	6.94	6.96	2.09	67.1
10	76.81	10.31	6.94	3.37	2.02	66.3
15	61.77	8.29	6.94	1.35	1.22	55.6
20	52.03	6.98	6.41	0.57	0.89	46.2
25	45.17	6.06	5.70	0.36	0.55	41.1
30	40.04	5.38	5.13	0.24	0.43	37.0
35	36.06	4.84	4.68	0.16	0.34	33.7
40	32.86	4.41	4.30	0.11	0.27	31.0
45	30.24	4.06	3.98	0.07	0.20	28.7
50	28.04	3.76	3.71	0.05	0.15	26.8
55	26.17	3.51	3.48	0.03	0.10	25.1
60	24.56	3.30	3.27	0.03	0.09	23.6

Storage: Roof Storage

Depth (mm)	Head (m)	Discharge (L/s)	Vreq (cu. m)	Vavail (cu. m)	Discharge Check	
5-year Water Level	67.14	0.07	6.94	2.09	21.46	

Subdrainage Area: ROOF2B
Area (ha): 0.01
C: 0.90
Maximum Storage Depth: 150 mm

tc (min)	I (5 yr) (mm/hr)	Qactual (L/s)	Qrelease (L/s)	Qstored (L/s)	Vstored (m³)	Depth (mm)
5	103.57	3.14	1.89	1.24	0.37	61.4
10	76.81	2.33	1.89	0.43	0.26	54.8
15	61.77	1.87	1.71	0.16	0.15	45.1
20	52.03	1.58	1.48	0.09	0.11	39.2
25	45.17	1.37	1.31	0.06	0.08	34.7
30	40.04	1.21	1.18	0.03	0.06	31.2
35	36.06	1.09	1.07	0.02	0.04	28.3
40	32.86	1.00	0.98	0.01	0.03	26.0
45	30.24	0.92	0.91	0.01	0.02	24.0
50	28.04	0.85	0.84	0.01	0.02	22.2
55	26.17	0.79	0.79	0.01	0.02	20.8
60	24.56	0.74	0.74	0.00	0.02	19.5

Storage: Roof Storage

Depth (mm)	Head (m)	Discharge (L/s)	Vreq (cu. m)	Vavail (cu. m)	Discharge Check	
5-year Water Level	61.39	0.06	1.89	0.37	4.84	

Subdrainage Area: ROOF3
Area (ha): 0.10
C: 0.90
Maximum Storage Depth: 150 mm

tc (min)	I (5 yr) (mm/hr)	Qactual (L/s)	Qrelease (L/s)	Qstored (L/s)	Vstored (m³)	Depth (mm)
5	103.57	25.23	5.07	20.17	6.05	79.4
10	76.81	18.71	5.23	13.48	8.09	87.1
15	61.77	15.05	5.29	9.76	8.78	89.7
20	52.03	12.68	5.30	7.38	8.85	89.9
25	45.17	11.00	5.28	5.73	8.59	88.9
30	40.04	9.76	5.24	4.52	8.13	87.2

Project #160401689, 2475 Regina Street Modified Rational Method Calculations for Storage

100 yr Intensity City of Ottawa	$I = a/(t + b)^c$	a =	1735.688	t (min)	I (mm/hr)
		b =	6.014		
		c =	0.820		
				10	178.56
				20	119.95
				30	91.87
				40	75.15
				50	63.95
				60	55.89
				70	49.79
				80	44.99
				90	41.11
				100	37.90
				110	35.20
				120	32.89

100 YEAR Modified Rational Method for Entire Site

Subdrainage Area: ROOF2A
Area (ha): 0.04
C: 1.00
Maximum Storage Depth: 150 mm

tc (min)	I (100 yr) (mm/hr)	Qactual (L/s)	Qrelease (L/s)	Qstored (L/s)	Vstored (m³)	Depth (mm)
10	178.56	19.79	3.15	16.64	9.98	127.8
20	119.95	13.90	3.15	10.75	12.17	135.9
30	91.87	10.18	3.15	7.03	12.65	137.7
40	75.15	8.33	3.15	5.18	12.42	136.9
50	63.95	7.09	3.15	3.93	11.80	134.6
60	55.89	6.20	3.15	3.04	10.95	131.4
70	49.79	5.52	3.15	2.36	9.93	127.6
80	44.99	4.99	3.15	1.83	8.80	122.6
90	41.11	4.56	3.15	1.40	7.57	115.8
100	37.90	4.20	3.15	1.05	6.28	108.6
110	35.20	3.90	3.15	0.75	4.94	101.2
120	32.89	3.65	3.15	0.49	3.54	89.2

Storage: Roof Storage

Depth (mm)	Head (m)	Discharge (L/s)	Vreq (cu. m)	Vavail (cu. m)	Discharge Check	
100-year Water Level	137.73	0.14	3.15	12.65	15.95	0.00

Subdrainage Area: ROOF1
Area (ha): 0.05
C: 1.00
Maximum Storage Depth: 150 mm

tc (min)	I (100 yr) (mm/hr)	Qactual (L/s)	Qrelease (L/s)	Qstored (L/s)	Vstored (m³)	Depth (mm)
10	178.56	26.63	6.94	19.69	11.82	122.5
20	119.95	17.89	6.94	10.95	13.14	127.0
30	91.87	13.70	6.94	6.76	12.17	124.0
40	75.15	11.21	6.94	4.27	10.24	116.0
50	63.95	9.54	6.94	2.60	7.80	105.9
60	55.89	8.34	6.94	1.40	5.03	91.0
70	49.79	7.43	6.94	0.49	2.04	66.5
80	44.99	6.71	6.56	0.15	0.72	47.3
90	41.11	6.13	6.02	0.11	0.61	43.4
100	37.90	5.65	5.57	0.09	0.52	40.1
110	35.20	5.25	5.18	0.07	0.44	37.3
120	32.89	4.91	4.85	0.05	0.38	35.0

Storage: Roof Storage

Depth (mm)	Head (m)	Discharge (L/s)	Vreq (cu. m)	Vavail (cu. m)	Discharge Check	
100-year Water Level	127.00	0.13	6.94	13.14	21.46	

Subdrainage Area: ROOF2B
Area (ha): 0.01
C: 1.00
Maximum Storage Depth: 150 mm

tc (min)	I (100 yr) (mm/hr)	Qactual (L/s)	Qrelease (L/s)	Qstored (L/s)	Vstored (m³)	Depth (mm)
10	178.56	6.01	1.89	4.12	2.47	118.9
20	119.95	4.04	1.89	2.14	2.57	120.8
30	91.87	3.09	1.89	1.20	2.16	113.2
40	75.15	2.53	1.89	0.64	1.53	101.7
50	63.95	2.15	1.89	0.26	0.78	80.3
60	55.89	1.88	1.83	0.05	0.17	48.5
70	49.79	1.68	1.64	0.03	0.14	43.4
80	44.99	1.51	1.49	0.02	0.11	39.4
90	41.11	1.38	1.37	0.02	0.09	36.1
100	37.90	1.28	1.26	0.01	0.07	33.4
110	35.20	1.18	1.18	0.01	0.06	31.1
120	32.89	1.11	1.10	0.01	0.05	29.1

Storage: Roof Storage

Depth (mm)	Head (m)	Discharge (L/s)	Vreq (cu. m)	Vavail (cu. m)	Discharge Check	
100-year Water Level	120.82	0.12	1.89	2.57	4.84	

Subdrainage Area: ROOF3
Area (ha): 0.10
C: 1.00
Maximum Storage Depth: 150 mm

tc (min)	I (100 yr) (mm/hr)	Qactual (L/s)	Qrelease (L/s)	Qstored (L/s)	Vstored (m³)	Depth (mm)
10	178.56	48.33	6.17	42.17	25.30	129.2
20	119.95	32.47	6.37	26.10	31.32	138.4
30	91.87	24.87	6.43	18.44	33.19	141.2
40	75.15	20.34	6.44	13.90	33.37	141.5
50	63.95	17.31	6.41	10.90	32.69	140.5
60	55.89	15.13	6.37	8.76	31.52	138.7

Stormwater Management Calculations

Project #160401689, 2475 Regina Street

Modified Rational Method Calculations for Storage

35	36.06	8.78	5.19	3.59	7.55	85.0	0.00
40	32.86	8.01	5.14	2.87	6.89	82.6	0.00
45	30.24	7.37	5.08	2.29	6.18	79.9	0.00
50	28.04	6.83	5.02	1.82	5.45	77.2	0.00
55	26.17	6.38	4.94	1.43	4.72	73.9	0.00
60	24.56	5.98	4.84	1.14	4.10	69.4	0.00

Storage: Roof Storage

	Depth (mm)	Head (m)	Discharge (L/s)	Vreq (cu. m)	Vavail (cu. m)	Discharge Check
5-year Water Level	89.93	0.09	5.30	8.85	38.95	0.00

Project #160401689, 2475 Regina Street

Modified Rational Method Calculations for Storage

70	49.79	13.48	6.32	7.15	30.04	136.4	0.00
80	44.99	12.18	6.27	5.91	28.37	133.9	0.00
90	41.11	11.13	6.21	4.92	26.57	131.1	0.00
100	37.90	10.26	6.14	4.12	24.69	128.3	0.00
110	35.20	9.53	6.08	3.45	22.76	125.3	0.00
120	32.89	8.90	5.99	2.91	20.96	121.4	0.00

Storage: Roof Storage

	Depth (mm)	Head (m)	Discharge (L/s)	Vreq (cu. m)	Vavail (cu. m)	Discharge Check
100-year Water Level	141.50	0.14	6.44	33.37	38.95	0.00

Roof Drain Design Calculation Sheet

**Project #160401689, 2475 Regina Street
Roof Drain Design Sheet, Area ROOF1
Watts Adjustable Accutrol Weir**

Rating Curve				Volume Estimation				Water Depth (m)
Elevation (m)	Discharge Rate (cu.m/s)	Outlet Discharge (cu.m/s)	Storage (cu. m)	Elevation (m)	Area (sq. m)	Volume (cu. m)		
						Increment	Accumulated	
0.000	0.0000	0.0000	0	0.000	0	0	0	0.000
0.025	0.0003	0.0035	0	0.025	12	0	0	0.025
0.050	0.0006	0.0069	1	0.050	48	1	1	0.050
0.075	0.0006	0.0069	3	0.075	107	2	3	0.075
0.100	0.0006	0.0069	6	0.100	191	4	6	0.100
0.125	0.0006	0.0069	12	0.125	298	6	12	0.125
0.150	0.0006	0.0069	21	0.150	429	9	21	0.150

Drawdown Estimate			
Total Volume (cu.m)	Total Time (sec)	Vol (cu.m)	Detention Time (hr)
0.0	0.0	0.0	0
0.7	100.2	0.7	0.02784
2.6	272.0	1.9	0.1034
6.3	529.7	3.7	0.25054
12.3	873.3	6.1	0.49313
21.4	1302.8	9.0	0.85503

Rooftop Storage Summary

Total Building Area (sq.m)		536.53	
Assume Available Roof Area (sq. 80%)		429.224	
Roof Imperviousness		0.99	
Roof Drain Requirement (sq.m/Notch)		232	
Number of Roof Notches*		11	
Max. Allowable Depth of Roof Ponding (m)		0.15	* As per Ontario Building Code section OBC 7.4.10.4.(2)(c).
Max. Allowable Storage (cu.m)		21	
Estimated 100 Year Drawdown Time (h)		0.5	

From Watts Drain Catalogue

Head (m) L/s					
Open	0.75	0.5	0.25	Closed	
0.025	0.3155	0.3155	0.3155	0.3155	0.3155
0.05	0.6309	0.6309	0.6309	0.6309	0.6309
0.075	0.9464	0.8675	0.7886	0.7098	0.6309
0.1	1.2618	1.1041	0.9464	0.7886	0.6309
0.125	1.5773	1.3407	1.1041	0.8675	0.6309
0.15	1.8927	1.5773	1.2618	0.9464	0.6309

* Note: Number of drains can be reduced if multiple-notch drain used.

Calculation Results

	5yr	100yr	Available
Qresult (cu.m/s)	0.007	0.007	-
Depth (m)	0.067	0.127	0.150
Volume (cu.m)	2.1	13.1	21.5
Drain time (hrs)	0.1	0.5	

Roof Drain Design Calculation Sheet

**Project #160401689, 2475 Regina Street
Roof Drain Design Sheet, Area ROOF2
Watts Adjustable Accutrol Weir**

Rating Curve				Volume Estimation				Water Depth (m)
Elevation (m)	Discharge Rate (cu.m/s)	Outlet Discharge (cu.m/s)	Storage (cu. m)	Elevation (m)	Area (sq. m)	Volume (cu. m)		
						Increment	Accumulated	
0.000	0.0000	0.0000	0	0.000	0	0	0	0.000
0.025	0.0003	0.0009	0	0.025	3	0	0	0.025
0.050	0.0006	0.0019	0	0.050	11	0	0	0.050
0.075	0.0006	0.0019	1	0.075	24	0	1	0.075
0.100	0.0006	0.0019	1	0.100	43	1	1	0.100
0.125	0.0006	0.0019	3	0.125	67	1	3	0.125
0.150	0.0006	0.0019	5	0.150	97	2	5	0.150

Drawdown Estimate			
Total Volume (cu.m)	Total Time (sec)	Vol (cu.m)	Detention Time (hr)
0.0	0.0	0.0	0
0.2	82.9	0.2	0.02304
0.6	225.1	0.4	0.08556
1.4	438.3	0.8	0.20732
2.8	722.6	1.4	0.40805
4.8	1078.0	2.0	0.70751

Rooftop Storage Summary

Total Building Area (sq.m)		121.08	
Assume Available Roof Area (sq. 80%)		96.864	
Roof Imperviousness		0.99	
Roof Drain Requirement (sq.m/Notch)		232	
Number of Roof Notches*		3	
Max. Allowable Depth of Roof Ponding (m)		0.15	* As per Ontario Building Code section OBC 7.4.10.4.(2)(c).
Max. Allowable Storage (cu.m)		5	
Estimated 100 Year Drawdown Time (h)		0.4	

From Watts Drain Catalogue

Head (m) L/s					
Open	0.75	0.5	0.25	Closed	
0.025	0.3155	0.3155	0.3155	0.3155	0.3155
0.05	0.6309	0.6309	0.6309	0.6309	0.6309
0.075	0.9464	0.8675	0.7886	0.7098	0.6309
0.1	1.2618	1.1041	0.9464	0.7886	0.6309
0.125	1.5773	1.3407	1.1041	0.8675	0.6309
0.15	1.8927	1.5773	1.2618	0.9464	0.6309

* Note: Number of drains can be reduced if multiple-notch drain used.

Calculation Results

	5yr	100yr	Available
Qresult (cu.m/s)	0.002	0.002	-
Depth (m)	0.061	0.121	0.150
Volume (cu.m)	0.4	2.6	4.8
Drain time (hrs)	0.1	0.4	

Roof Drain Design Calculation Sheet

**Project #160401689, 2475 Regina Street
Roof Drain Design Sheet, Area ROOF2A
Watts Adjustable Accutrol Weir**

Rating Curve				Volume Estimation				Water Depth (m)
Elevation (m)	Discharge Rate (cu.m/s)	Outlet Discharge (cu.m/s)	Storage (cu. m)	Elevation (m)	Area (sq. m)	Volume (cu. m)		
						Increment	Accumulated	
0.000	0.0000	0.0000	0	0.000	0	0	0	0.000
0.025	0.0003	0.0016	0	0.025	9	0	0	0.025
0.050	0.0006	0.0032	1	0.050	35	1	1	0.050
0.075	0.0006	0.0032	2	0.075	80	1	2	0.075
0.100	0.0006	0.0032	5	0.100	142	3	5	0.100
0.125	0.0006	0.0032	9	0.125	222	5	9	0.125
0.150	0.0006	0.0032	16	0.150	319	7	16	0.150

Drawdown Estimate			
Total Volume (cu.m)	Total Time (sec)	Vol (cu.m)	Detention Time (hr)
0.0	0.0	0.0	0
0.5	163.9	0.5	0.04552
1.9	444.8	1.4	0.16906
4.7	866.1	2.7	0.40965
9.2	1427.9	4.5	0.8063
15.9	2130.2	6.7	1.39801

Rooftop Storage Summary

Total Building Area (sq.m)		398.75	
Assume Available Roof Area (sq. 80%)		319	
Roof Imperviousness		0.99	
Roof Drain Requirement (sq.m/Notch)		232	
Number of Roof Notches*		5	
Max. Allowable Depth of Roof Ponding (m)		0.15	* As per Ontario Building Code section OBC 7.4.10.4.(2)(c).
Max. Allowable Storage (cu.m)		16	
Estimated 100 Year Drawdown Time (h)		1.1	

From Watts Drain Catalogue

Head (m) L/s					
Open	0.75	0.5	0.25	Closed	
0.025	0.3155	0.3155	0.3155	0.3155	0.3155
0.05	0.6309	0.6309	0.6309	0.6309	0.6309
0.075	0.9464	0.8675	0.7886	0.7098	0.6309
0.1	1.2618	1.1041	0.9464	0.7886	0.6309
0.125	1.5773	1.3407	1.1041	0.8675	0.6309
0.15	1.8927	1.5773	1.2618	0.9464	0.6309

* Note: Number of drains can be reduced if multiple-notch drain used.

Calculation Results

	5yr	100yr	Available
Qresult (cu.m/s)	0.003	0.003	-
Depth (m)	0.082	0.138	0.150
Volume (cu.m)	2.7	12.7	16.0
Drain time (hrs)	0.2	1.1	

Roof Drain Design Calculation Sheet

**Project #160401689, 2475 Regina Street
Roof Drain Design Sheet, Area ROOF3
Watts Adjustable Accutrol Weir**

Rating Curve				Volume Estimation				Water Depth (m)
Elevation (m)	Discharge Rate (cu.m/s)	Outlet Discharge (cu.m/s)	Storage (cu. m)	Elevation (m)	Area (sq. m)	Volume (cu. m)		
						Increment	Accumulated	
0.000	0.0000	0.0000	0	0.000	0	0	0	0.000
0.025	0.0003	0.0022	0	0.025	22	0	0	0.025
0.050	0.0006	0.0044	1	0.050	87	1	1	0.050
0.075	0.0007	0.0050	5	0.075	195	3	5	0.075
0.100	0.0008	0.0055	12	0.100	346	7	12	0.100
0.125	0.0009	0.0061	23	0.125	541	11	23	0.125
0.150	0.0009	0.0066	39	0.150	779	16	39	0.150

Drawdown Estimate			
Total Volume (cu.m)	Total Time (sec)	Vol (cu.m)	Detention Time (hr)
0.0	0.0	0.0	0
1.3	285.8	1.3	0.07939
4.7	689.6	3.4	0.27094
11.4	1208.6	6.7	0.60665
22.4	1811.4	11.0	1.1098
38.8	2477.0	16.4	1.79786

Rooftop Storage Summary

Total Building Area (sq.m)		973.71	
Assume Available Roof Area (sq. 80%)		778.968	
Roof Imperviousness		0.99	
Roof Drain Requirement (sq.m/Notch)		232	
Number of Roof Notches*		7	
Max. Allowable Depth of Roof Ponding (m)		0.15	* As per Ontario Building Code section OBC 7.4.10.4.(2)(c).
Max. Allowable Storage (cu.m)		39	
Estimated 100 Year Drawdown Time (h)		1.6	

From Watts Drain Catalogue

Head (m) L/s					
Open	0.75	0.5	0.25	Closed	
0.025	0.3155	0.3155	0.3155	0.3155	0.3155
0.05	0.6309	0.6309	0.6309	0.6309	0.6309
0.075	0.9464	0.8675	0.7886	0.7098	0.6309
0.1	1.2618	1.1041	0.9464	0.7886	0.6309
0.125	1.5773	1.3407	1.1041	0.8675	0.6309
0.15	1.8927	1.5773	1.2618	0.9464	0.6309

* Note: Number of drains can be reduced if multiple-notch drain used.

Calculation Results

	5yr	100yr	Available
Qresult (cu.m/s)	0.005	0.006	-
Depth (m)	0.090	0.142	0.150
Volume (cu.m)	8.9	33.4	38.9
Draintime (hrs)	0.5	1.6	



Adjustable Accutrol Weir
 Tag: _____

**Adjustable Flow Control
 for Roof Drains**

ADJUSTABLE ACCUTROL (for Large Sump Roof Drains only)

For more flexibility in controlling flow with heads deeper than 2", Watts Drainage offers the Adjustable Accutrol. The Adjustable Accutrol Weir is designed with a single parabolic opening that can be covered to restrict flow above 2" of head to less than 5 gpm per inch, up to 6" of head. To adjust the flow rate for depths over 2" of head, set the slot in the adjustable upper cone according to the flow rate required. Refer to Table 1 below.
 Note: Flow rates are directly proportional to the amount of weir opening that is exposed.

EXAMPLE:

For example, if the adjustable upper cone is set to cover 1/2 of the weir opening, flow rates above 2" of head will be restricted to 2-1/2 gpm per inch of head.

Therefore, at 3" of head, the flow rate through the Accutrol Weir that has 1/2 the slot exposed will be:
 [5 gpm (per inch of head) x 2 inches of head] + 2-1/2 gpm (for the third inch of head) = 12-1/2 gpm.

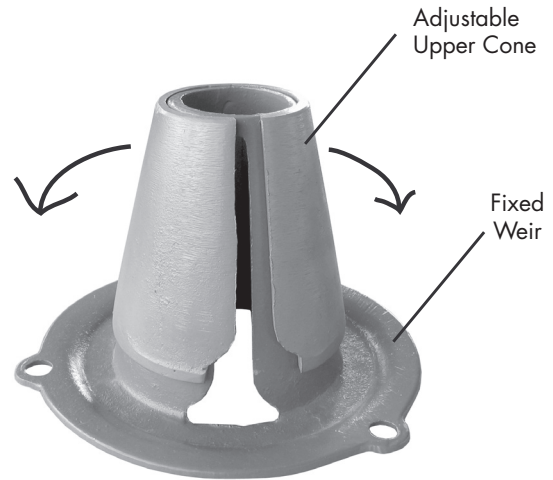
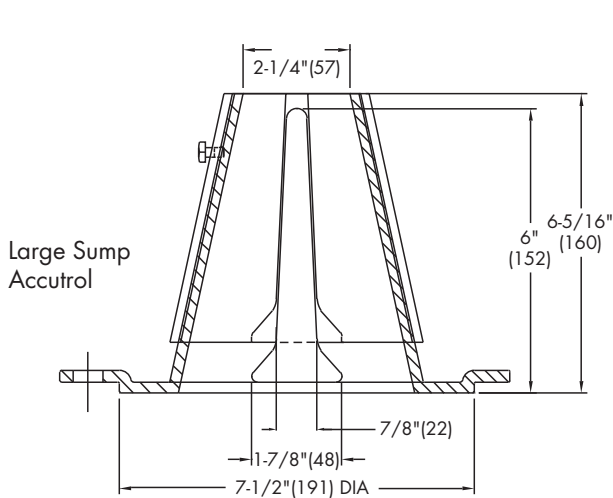

1/2 Weir Opening Exposed Shown Above

TABLE 1. Adjustable Accutrol Flow Rate Settings

Weir Opening Exposed	1"	2"	3"	4"	5"	6"
	Flow Rate (gallons per minute)					
Fully Exposed	5	10	15	20	25	30
3/4	5	10	13.75	17.5	21.25	25
1/2	5	10	12.5	15	17.5	20
1/4	5	10	11.25	12.5	13.75	15
Closed	5	5	5	5	5	5

Job Name _____
 Job Location _____
 Engineer _____

Contractor _____
 Contractor's P.O. No. _____
 Representative _____

Watts product specifications in U.S. customary units and metric are approximate and are provided for reference only. For precise measurements, please contact Watts Technical Service. Watts reserves the right to change or modify product design, construction, specifications, or materials without prior notice and without incurring any obligation to make such changes and modifications on Watts products previously or subsequently sold.

USA: Tel: (800) 338-2581 • Fax: (828) 248-3929 • Watts.com
Canada: Tel: (905) 332-4090 • Fax: (905) 332-7068 • Watts.ca
Latin America: Tel: (52) 81-1001-8600 • Fax: (52) 81-8000-7091 • Watts.com



Next Generation Inlet Control Devices



STORMWATER MANAGEMENT SYSTEMS

THE SOLUTION FOR STORMWATER POLLUTION

- Maintenance free system with no moving parts
- Designed to handle a wide range of flows
- Fast and easy to install and maintain



We build tough products for tough environments®



CONTROL SANITARY BACK-UP DURING PEAK FLOW EVENTS



Cities across North America are designed with a significant number of catch basins connected to combined sewers. When a substantial rain occurs, combined sewers are overloaded with stormwater and cause sanitary back up in houses, lakes and streams. This is a major environmental concern.

The Tempest™ line of Inlet Control Devices (ICD's) is used to control flow into storm sewers during these peak flow events. Tempest ICD's are designed to allow a specific flow volume out of a catchbasin or manhole at a specified head. This causes the excess stormwater to be temporarily stored in the upstream piping system or above ground. Avoid environmental and structural degradation by conserving pipe capacity so that downstream infrastructure does not become uncontrollably surcharged.

TEMPEST™ Vortex ICD



Available in seven pre-set flow rates, ranging from 2 l/s to 17 l/s (0.07 cfs to 0.60 cfs). The Tempest Vortex Inlet Control Device allows a near constant discharge rate to be set. These devices are easily installed over the catchbasin outlet pipe, and include a quick release mechanism to allow easy access for maintenance without the need to drain the installation. The Vortex ICD is designed specifically for low to moderate flow rates with an engineered design that eliminates the passage of odours and floatables.

- Restricts flow to a narrow range
- Prevents propagation of floatables & odour through the system
- Simple insert adjustment changes flow rate capacity
- Virtually maintenance free with no moving parts
- Neoprene gasket for air-tight seal
- Utilize a reach bar and simply lift out the unit for any adjustments

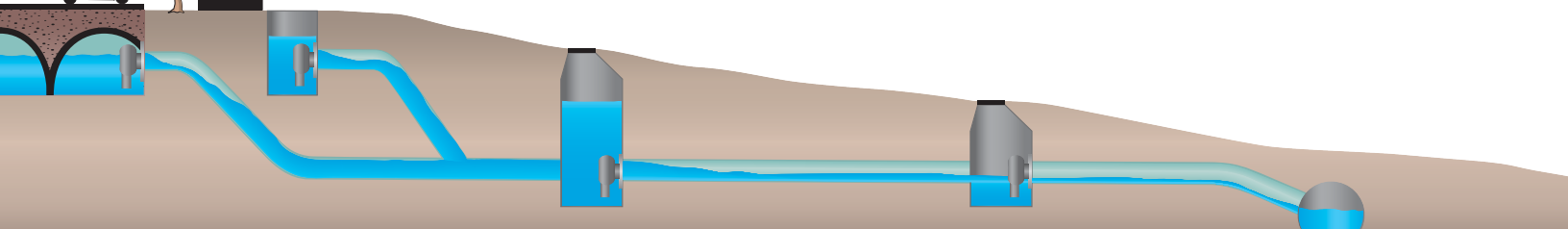
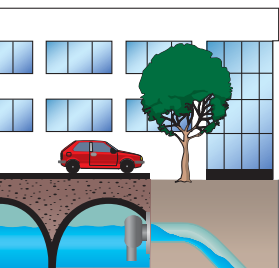
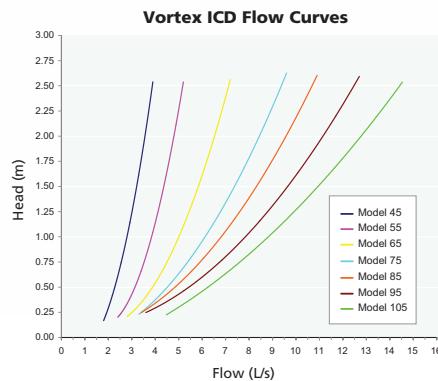



TEMPEST™ F.O.F ICD

The Tempest F.O.F (floatable, odour and flow) unit meets the needs of typically larger flows of 15L/s (0.53 cfs) or greater.

- Restricts the passage of floatables, odour and flow
- Easily installed over existing catch basin outlet pipe
- Neoprene gasket for air-tight seal
- Utilize a reach bar to simply lift out the unit for any adjustments



TEMPEST™ Plate ICD

The Tempest Plate ICD is a standard orifice plate device designed to allow a specified flow volume out of a catchbasin at a specified head.

- Restricts flow



TEMPEST™ SUMP

Designed for catchbasins & manholes in which there is no sump or the outlet pipe is too low to install F.O.F device. The Tempest SUMP system raises the outlet off the bottom allowing for debris and sediment to collect in the structure.

- Creates sump in structure
- Restricts the passage of floatables, odor and flow
- Easily installed over existing catchbasin outlet pipe



TEMPEST F.O.F, PLATE AND SUMP FLOW CURVES

Type A, B & C Calibration Curves

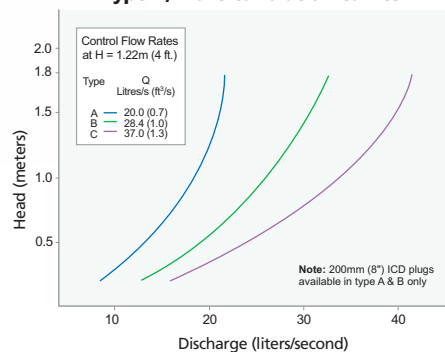

Type D & F Calibration Curves

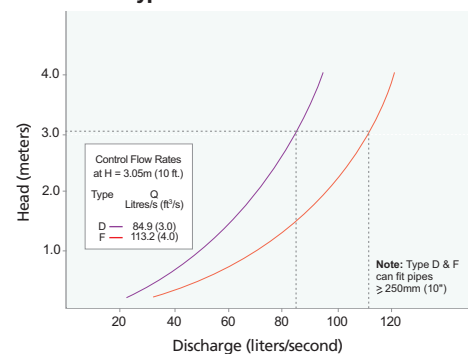

SALES AND CUSTOMER SERVICE

Canadian Customers call IPEX Inc.

Toll free: (866) 473-9462

www.ipexinc.com

U.S. Customers call IPEX USA LLC

Toll free: (800) 463-9572

www.ipexamerica.com

About the IPEX Group of Companies

As leading suppliers of thermoplastic piping systems, the IPEX Group of Companies provides our customers with some of the largest and most comprehensive product lines. All IPEX products are backed by more than 50 years of experience. With state-of-the-art manufacturing facilities and distribution centers across North America, we have established a reputation for product innovation, quality, end-user focus and performance.

Markets served by IPEX group products are:

- Electrical systems
- Telecommunications and utility piping systems
- PVC, PVCO, CPVC, PP, ABS, PEX, FR-PVDF and PE pipe and fittings (1/4" to 48")
- Industrial process piping systems
- Municipal pressure and gravity piping systems
- Plumbing and mechanical piping systems
- PE Electrofusion systems for gas and water
- Industrial, plumbing and electrical cements
- Irrigation systems

Products manufactured for IPEX Inc. and distributed in the US by IPEX USA LLC.

Tempest™ is a trademark of IPEX Branding Inc.

This literature is published in good faith and is believed to be reliable. However, it does not represent and/or warrant in any manner the information and suggestions contained in this brochure. Data presented is the result of laboratory tests and field experience.

A policy of ongoing product improvement is maintained. This may result in modifications of features and/or specifications without notice.



D.2 PCSWMM Model Input



```

[TITLE]
;;Project Title/Notes

[OPTIONS]
;;Option          Value
FLOW_UNITS        LPS
INFILTRATION      HORTON
FLOW_ROUTING      DYNWAVE
LINK_OFFSETS      ELEVATION
MIN_SLOPE          0
ALLOW_PONDING     NO
SKIP_STEADY_STATE NO

START_DATE        03/07/2024
START_TIME        00:00:00
REPORT_START_DATE 03/07/2024
REPORT_START_TIME 00:00:00
END_DATE          03/08/2024
END_TIME          00:00:00
SWEEP_START       01/01
SWEEP_END         12/31
DRY_DAYS          0
REPORT_STEP       00:01:00
WET_STEP          00:01:00
DRY_STEP          00:01:00
ROUTING_STEP      1
RULE_STEP         00:00:00

INERTIAL_DAMPING  PARTIAL
NORMAL_FLOW_LIMITED BOTH
FORCE_MAIN_EQUATION H-W
VARIABLE_STEP     0
LENGTHENING_STEP 0
MIN_SURFAREA      0
MAX_TRIALS        8
HEAD_TOLERANCE    0.0015
SYS_FLOW_TOL      5
LAT_FLOW_TOL      5
MINIMUM_STEP      0.5

```

```

THREADS          8

[EVAPORATION]
;;Data Source    Parameters
;;-----
CONSTANT         0.0
DRY_ONLY         NO

[RAINGAGES]
;;Name           Format   Interval SCF   Source
;;-----
RG-C             INTENSITY 0:10   1.0   TIMESERIES 100C
RG-S             INTENSITY 0:15   1.0   TIMESERIES 100S

[SUBCATCHMENTS]
;;Name           Rain Gage      Outlet          Area    %Imperv  Width  %Slope  CurbLen  SnowPack
;;-----
;0.90
CB-1             RG-C          CB1             0.09776 100     121    3       0
;0.80
CB-2             RG-C          103             0.046699 85.71   33     3       0
;0.90
DRN2A           RG-C          103             0.048744 100     41     3       0
;0.69
DRN2B           RG-C          103             0.080316 71.43   27     3       0
;0.30
GRN-1           RG-C          103             0.028075 14.29   6.317  2       0
;0.30
GRN-2           RG-C          103             0.065024 14.29   14.63  2       0
;0.30
GRN-3           RG-C          103             0.021139 14.29   4.756  2       0

```

```

;0.76
L102A      RG-C      L102A-S      0.123391 80      51      3      0

;0.90
L103A      RG-C      L103A-S      0.052226 100     40      3      0

;0.26
LID-1      RG-C      LID1A        0.116      8.57     26.1    3      0

;0.50
LID-2      RG-C      LID2         0.062741 42.86    39      3      0

;0.30
LID-3      RG-C      LID3-U       0.080829 14.29    103     3      0

;0.90
RAMP       RG-C      103          0.009377 100     15      15     0

;0.90
ROOF-1     RG-C      ROOF1-S      0.053653 100     12.072  2      0

;0.90
ROOF-2A    RG-C      ROOF2A-S     0.039875 100     8.972   2      0

;0.90
ROOF-2B    RG-C      ROOF2B-S     0.012108 100     2.724   2      0

;0.90
ROOF-3     RG-C      ROOF3-S      0.097371 100     21.908  2      0

```

[SUBAREAS]

```

;;Subcatchment N-Imperv N-Perv S-Imperv S-Perv PctZero RouteTo PctRouted
;;-----
CB-1            0.013  0.25  1.57  4.67  0      OUTLET
CB-2            0.013  0.25  1.57  4.67  0      OUTLET
DRN2A           0.013  0.25  1.57  4.67  0      OUTLET
DRN2B           0.013  0.25  1.57  4.67  0      OUTLET

```

```

GRN-1          0.013  0.25  1.57  4.67  0      OUTLET
GRN-2          0.013  0.25  1.57  4.67  0      OUTLET
GRN-3          0.013  0.25  1.57  4.67  0      OUTLET
L102A          0.013  0.25  1.57  4.67  0      OUTLET
L103A          0.013  0.25  1.57  4.67  0      OUTLET
LID-1          0.013  0.25  1.57  4.67  0      OUTLET
LID-2          0.013  0.25  1.57  4.67  0      OUTLET
LID-3          0.013  0.25  1.57  4.67  0      OUTLET
RAMP           0.013  0.25  1.57  4.67  0      OUTLET
ROOF-1         0.013  0.25  1.57  4.67  0      OUTLET
ROOF-2A        0.013  0.25  1.57  4.67  0      OUTLET
ROOF-2B        0.013  0.25  1.57  4.67  0      OUTLET
ROOF-3         0.013  0.25  1.57  4.67  0      OUTLET

```

[INFILTRATION]

```

;;Subcatchment Param1 Param2 Param3 Param4 Param5
;;-----
CB-1            76.2   13.2   4.14   7      0
CB-2            76.2   13.2   4.14   7      0
DRN2A           76.2   13.2   4.14   7      0
DRN2B           76.2   13.2   4.14   7      0
GRN-1           76.2   13.2   4.14   7      0
GRN-2           76.2   13.2   4.14   7      0
GRN-3           76.2   13.2   4.14   7      0
L102A           76.2   13.2   4.14   7      0
L103A           76.2   13.2   4.14   7      0
LID-1           76.2   13.2   4.14   7      0
LID-2           76.2   13.2   4.14   7      0
LID-3           76.2   13.2   4.14   7      0
RAMP            76.2   13.2   4.14   7      0
ROOF-1         76.2   13.2   4.14   7      0
ROOF-2A        76.2   13.2   4.14   7      0
ROOF-2B        76.2   13.2   4.14   7      0
ROOF-3         76.2   13.2   4.14   7      0

```

[LID_CONTROLS]

```

;;Name Type/Layer Parameters
;;-----
GREEN-ROOF GR

```

GREEN-ROOF	SURFACE	150	0.3	0.035	1.5	5		
GREEN-ROOF	SOIL	200	0.46	0.23	0.12	3.3	10.0	3.5
GREEN-ROOF	DRAINMAT	5	0.5	0.1				

[LID_USAGE]

```

;;Subcatchment LID Process Number Area Width InitSat FromImp ToPerv RptFile
                DrainTo      FromPerv
;-----

```

[OUTFALLS]

```

;;Name Elevation Type Stage Data Gated Route To
;-----
EX-STRM 63.05 FREE
OF-LID1 62.25 FREE
OF-LID2 63.33 FREE

```

[STORAGE]

```

;;Name Elev. MaxDepth InitDepth Shape Curve Name/Params SurDepth Fevap
Psi Ksat IMD
;-----
100 63.43 1.761 0 FUNCTIONAL 0 0 1.13 0 0
101 63.67 1.57 0 FUNCTIONAL 0 0 1.13 0 0
102 63.79 1.47 0 FUNCTIONAL 0 0 1.13 0 0
103 63.9 1.33 0 FUNCTIONAL 0 0 1.13 0 0
CB1 63.72 1.78 0 TABULAR CB1-V 0 0
IRR-TANK 80 1.3 0 FUNCTIONAL 0 0 60 0 0
IRR-TANK2 80 1.3 0 FUNCTIONAL 0 0 30 0 0
L102A-S 63.95 1.41 0 TABULAR L102A-V 0 0
L103A-S 64.03 1.3 0 TABULAR L103A-V 0 0
LID1A 63.09 0.45 0 TABULAR LID1A-V 0 0
LID1B 62.58 0.46 0 TABULAR LID1B-V 0 0
LID1C 62 0.45 0 TABULAR LID1C-V 0 0
LID2 64.85 0.5 0 TABULAR LID2-V 0 0
LID3 63.1 0.8 0 TABULAR LID3-V 0 0
LID3-U 65.22 0.13 0 FUNCTIONAL 0 0 0 0 0
ROOF1-S 100 0.15 0 TABULAR ROOF1-V 0 0
ROOF2A-S 100 0.15 0 TABULAR ROOF2A-V 0 0

```

```

ROOF2B-S 100 0.15 0 TABULAR ROOF2B-V 0 0
ROOF3-S 100 0.15 0 TABULAR ROOF3-V 0 0
TANK 62.5 2.5 1 TABULAR TANK-V 0 0

```

[CONDUITS]

```

;;Name From Node To Node Length Roughness InOffset OutOffset InitFlow
MaxFlow
;-----
100--EX 100 EX-STRM 63.9 0.013 63.43 63.05 0 0
101-TANK 101 TANK 8.1 0.013 63.67 63.65 0 0
102-101 102 101 29.1 0.013 63.79 63.73 0 0
103-102 103 102 31 0.013 63.9 63.84 0 0
LID2-U--LID2 LID3-U LID3 55.3 0.035 65.22 63.7 0 0

```

[PUMPS]

```

;;Name From Node To Node Pump Curve Status Startup Shutoff
;-----
OR1 CB1 103 1 ON 0 0

```

[ORIFICES]

```

;;Name From Node To Node Type Offset Qcoeff Gated CloseTime
;-----
IRR-TANK2-O IRR-TANK2 103 SIDE 81 0.61 NO 0
IRR-TANK-O IRR-TANK 103 SIDE 81 0.61 NO 0
L102A-O L102A-S 102 SIDE 63.95 0.572 NO 0
L103A-O L103A-S 102 SIDE 64.03 0.572 NO 0
TANK--100 TANK 100 SIDE 63.5 0.61 NO 0

```

[WEIRS]

```

;;Name From Node To Node Type CrestHt Qcoeff Gated EndCon
EndCoeff Surcharge RoadWidth RoadSurf Coeff. Curve
;-----

```

MJ-LID1B YES	LID1A	LID1B	TRANSVERSE	63.44	1.67	NO	0	0
MJ-LID1C YES	LID1B	LID1C	TRANSVERSE	62.94	1.67	NO	0	0
MJ-OF-LID1 YES	LID1C	OF-LID1	TRANSVERSE	62.35	1.67	NO	0	0
MJ-OF-LID2 YES	LID3	OF-LID2	TRANSVERSE	63.8	1.67	NO	0	0
W2 YES	TANK	100	TRANSVERSE	65	1.67	NO	0	0
W3 YES	CB1	103	TRANSVERSE	65.35	1.67	NO	0	0

[OUTLETS]
;;Name
Gated
;;

	From Node	To Node	Offset	Type	QTable/Qcoeff	Qexpon
LID3A-0 YES	LID2	103	65.05	TABULAR/HEAD	S30_GRATE	
ROOF1-0 NO	ROOF1-S	IRR-TANK	100	TABULAR/HEAD	ROOF1-Q	
ROOF2A-0 NO	ROOF2A-S	IRR-TANK2	100	TABULAR/HEAD	ROOF2A-Q	
ROOF2B-0 NO	ROOF2B-S	IRR-TANK2	100	TABULAR/HEAD	ROOF2B-Q	
ROOF3-0 NO	ROOF3-S	IRR-TANK	100	TABULAR/HEAD	ROOF3-Q	

[XSECTIONS]
;;Link
;;

	Shape	Geom1	Geom2	Geom3	Geom4	Barrels	Culvert
100--EX	CIRCULAR	0.3	0	0	0	1	
101-TANK	CIRCULAR	0.45	0	0	0	1	
102-101	CIRCULAR	0.45	0	0	0	1	
103-102	CIRCULAR	0.45	0	0	0	1	
LID2-U--LID2	TRIANGULAR	0.2	2	0	0	1	
IRR-TANK2-0	CIRCULAR	0.3	0	0	0		
IRR-TANK-0	CIRCULAR	0.3	0	0	0		

L102A-0	CIRCULAR	0.108	0	0	0
L103A-0	CIRCULAR	0.083	0	0	0
TANK--100	CIRCULAR	0.3	0	0	0
MJ-LID1B	RECT_OPEN	0.1	1	0	0
MJ-LID1C	RECT_OPEN	0.1	1	0	0
MJ-OF-LID1	RECT_OPEN	0.1	3	0	0
MJ-OF-LID2	RECT_OPEN	0.1	1	0	0
W2	RECT_OPEN	0.9	1.2	0	0
W3	RECT_OPEN	0.1	6	0	0

[LOSSES]
;;Link
;;

	Kentry	Kexit	Kavg	Flap Gate	Seepage
102-101	0	1.344	0	NO	0
103-102	0	1.344	0	NO	0

[CURVES]
;;Name
;;

	Type	X-Value	Y-Value
1	Pump4	0	0
1		1.38	21.2
1		1.73	23.7
1		1.78	24.1
ROOF1-Q	Rating	0	0
ROOF1-Q		0.025	3.47
ROOF1-Q		0.05	6.9399
ROOF1-Q		0.075	6.9399
ROOF1-Q		0.1	6.9399
ROOF1-Q		0.125	6.9399
ROOF1-Q		0.15	6.9399
ROOF2A-Q	Rating	0	0
ROOF2A-Q		0.025	1.5773
ROOF2A-Q		0.05	3.1545
ROOF2A-Q		0.075	3.1545
ROOF2A-Q		0.1	3.1545
ROOF2A-Q		0.125	3.1545
ROOF2A-Q		0.15	3.1545

ROOF2B-Q	Rating	0	0
ROOF2B-Q		0.025	0.9464
ROOF2B-Q		0.05	1.8927
ROOF2B-Q		0.075	1.8927
ROOF2B-Q		0.1	1.8927
ROOF2B-Q		0.125	1.8927
ROOF2B-Q		0.15	1.8927
ROOF3-Q	Rating	0	0
ROOF3-Q		0.025	2.2082
ROOF3-Q		0.05	4.4163
ROOF3-Q		0.075	4.9684
ROOF3-Q		0.1	5.5204
ROOF3-Q		0.125	6.0724
ROOF3-Q		0.15	6.6245
S30_GRATE	Rating	0	0
S30_GRATE		0.01	7.3
S30_GRATE		0.02	10.3
S30_GRATE		0.03	12.6
S30_GRATE		0.04	14.5
S30_GRATE		0.05	16.2
S30_GRATE		0.06	17.8
S30_GRATE		0.07	19.2
S30_GRATE		0.08	20.5
S30_GRATE		0.09	21.8
S30_GRATE		0.1	22.9
S30_GRATE		0.11	24.1
S30_GRATE		0.12	25.1
S30_GRATE		0.13	26.2
S30_GRATE		0.14	27.1
S30_GRATE		0.15	28.1
S30_GRATE		0.16	29
S30_GRATE		0.17	29.9
S30_GRATE		0.18	30.8
S30_GRATE		0.19	31.6
S30_GRATE		0.2	32.4
S30_GRATE		0.21	33.2

S30_GRATE		0.22	34
S30_GRATE		0.23	34.8
S30_GRATE		0.24	35.5
S30_GRATE		0.25	36.3
S30_GRATE		0.26	37
S30_GRATE		0.27	37.7
S30_GRATE		0.28	38.4
S30_GRATE		0.29	39.1
S30_GRATE		0.3	39.7
S30_GRATE		0.31	40.4
S30_GRATE		0.32	41
S30_GRATE		0.33	41.7
S30_GRATE		0.34	42.3
S30_GRATE		0.35	42.9
S30_GRATE		0.36	43.5
S30_GRATE		0.37	44.1
S30_GRATE		0.38	44.7
S30_GRATE		0.39	45.3
S30_GRATE		0.4	45.9
S30_GRATE		0.41	46.5
S30_GRATE		0.42	47
S30_GRATE		0.43	47.6
S30_GRATE		0.44	48.1
S30_GRATE		0.45	48.7
S30_GRATE		0.46	49.2
S30_GRATE		0.47	49.7
S30_GRATE		0.48	50.3
S30_GRATE		0.49	50.8
S30_GRATE		0.5	51.3

CB1-V	Storage	0	0.36
CB1-V		1.38	0.36
CB1-V		1.58	220.1
CB1-V		1.78	220.1

CC1-V	Storage	0	0
CC1-V		0.35	164

L102A-V	Storage	0	0.36
---------	---------	---	------

L102A-V		1	0.36
L102A-V		1.31	466.5
L103A-V	Storage	0	0.36
L103A-V		1	0.36
L103A-V		1.2	175
LID1A-V	Storage	0	14
LID1A-V		0.35	43
LID1B-V	Storage	0	14
LID1B-V		0.36	41
LID1C-V	Storage	0	8
LID1C-V		0.35	96.1
LID2-V	Storage	0	19
LID2-V		0.41	66.8
LID3-V	Storage	0	11
LID3-V		0.7	78
ROOF1-V	Storage	0	0
ROOF1-V		0.025	12
ROOF1-V		0.05	48
ROOF1-V		0.075	107
ROOF1-V		0.1	191
ROOF1-V		0.125	298
ROOF1-V		0.15	429
ROOF2A-V	Storage	0	0
ROOF2A-V		0.025	9
ROOF2A-V		0.05	35
ROOF2A-V		0.075	80
ROOF2A-V		0.1	142
ROOF2A-V		0.125	222
ROOF2A-V		0.15	319
ROOF2B-V	Storage	0	0

ROOF2B-V		0.025	3
ROOF2B-V		0.05	11
ROOF2B-V		0.075	24
ROOF2B-V		0.1	43
ROOF2B-V		0.125	67
ROOF2B-V		0.15	97
ROOF3-V	Storage	0	0
ROOF3-V		0.025	22
ROOF3-V		0.05	87
ROOF3-V		0.075	195
ROOF3-V		0.1	346
ROOF3-V		0.125	541
ROOF3-V		0.15	779
TANK-V	Storage	0	132.8775
TANK-V		0.875	132.8705315
TANK-V		0.901	132.8775
TANK-V		0.926	132.8705315
TANK-V		0.952	132.8775
TANK-V		0.977	132.8705315
TANK-V		1.002	271.653525
TANK-V		1.028	271.6535616
TANK-V		1.053	271.653525
TANK-V		1.079	271.6535616
TANK-V		1.104	259.8425014
TANK-V		1.129	259.842538
TANK-V		1.155	248.0314778
TANK-V		1.18	248.0315144
TANK-V		1.206	236.2204541
TANK-V		1.231	236.2204907
TANK-V		1.256	212.5984069
TANK-V		1.282	212.5984435
TANK-V		1.307	188.9763596
TANK-V		1.333	188.9763963
TANK-V		1.358	153.5432888
TANK-V		1.383	141.7323018
TANK-V		1.409	129.9212415
TANK-V		1.434	129.9212781

TANK-V	1.46	132.8775
TANK-V	1.485	132.8775
TANK-V	1.51	132.8775
TANK-V	1.536	132.8775
TANK-V	1.561	132.8775
TANK-V	1.56101	0

[TIMESERIES]

;;Name	Date	Time	Value
002C		0:00	0
002C		0:10	2.81
002C		0:20	3.5
002C		0:30	4.69
002C		0:40	7.3
002C		0:50	18.21
002C		1:00	76.81
002C		1:10	24.08
002C		1:20	12.36
002C		1:30	8.32
002C		1:40	6.3
002C		1:50	5.09
002C		2:00	4.29
002C		2:10	3.72
002C		2:20	3.29
002C		2:30	2.95
002C		2:40	2.68
002C		2:50	2.46
002C		3:00	2.28
002S		0:00	1.06
002S		0:15	1.06
002S		0:30	1.06
002S		0:45	1.06
002S		1:00	1.06
002S		1:15	1.06
002S		1:30	1.06
002S		1:45	1.06
002S		2:00	1.27

002S		2:15	1.27
002S		2:30	1.27
002S		2:45	1.27
002S		3:00	1.69
002S		3:15	1.69
002S		3:30	1.69
002S		3:45	1.69
002S		4:00	2.54
002S		4:15	2.54
002S		4:30	3.39
002S		4:45	3.39
002S		5:00	5.08
002S		5:15	5.08
002S		5:30	20.33
002S		5:45	55.90
002S		6:00	7.62
002S		6:15	7.62
002S		6:30	3.39
002S		6:45	3.39
002S		7:00	2.54
002S		7:15	2.54
002S		7:30	2.54
002S		7:45	2.54
002S		8:00	1.48
002S		8:15	1.48
002S		8:30	1.48
002S		8:45	1.48
002S		9:00	1.48
002S		9:15	1.48
002S		9:30	1.48
002S		9:45	1.48
002S		10:00	0.85
002S		10:15	0.85
002S		10:30	0.85
002S		10:45	0.85
002S		11:00	0.85
002S		11:15	0.85
002S		11:30	0.85
002S		11:45	0.85

002S	12:00	0
005C	0:00	0
005C	0:10	3.68
005C	0:20	4.58
005C	0:30	6.15
005C	0:40	9.61
005C	0:50	24.17
005C	1:00	104.19
005C	1:10	32.04
005C	1:20	16.34
005C	1:30	10.96
005C	1:40	8.29
005C	1:50	6.69
005C	2:00	5.63
005C	2:10	4.87
005C	2:20	4.3
005C	2:30	3.86
005C	2:40	3.51
005C	2:50	3.22
005C	3:00	2.98
005S	0:00	1.40
005S	0:15	1.40
005S	0:30	1.40
005S	0:45	1.40
005S	1:00	1.40
005S	1:15	1.40
005S	1:30	1.40
005S	1:45	1.40
005S	2:00	1.69
005S	2:15	1.69
005S	2:30	1.69
005S	2:45	1.69
005S	3:00	2.25
005S	3:15	2.25
005S	3:30	2.25
005S	3:45	2.25
005S	4:00	3.37

005S	4:15	3.37
005S	4:30	4.49
005S	4:45	4.49
005S	5:00	6.74
005S	5:15	6.74
005S	5:30	26.96
005S	5:45	74.15
005S	6:00	10.11
005S	6:15	10.11
005S	6:30	4.49
005S	6:45	4.49
005S	7:00	3.37
005S	7:15	3.37
005S	7:30	3.37
005S	7:45	3.37
005S	8:00	1.97
005S	8:15	1.97
005S	8:30	1.97
005S	8:45	1.97
005S	9:00	1.97
005S	9:15	1.97
005S	9:30	1.97
005S	9:45	1.97
005S	10:00	1.12
005S	10:15	1.12
005S	10:30	1.12
005S	10:45	1.12
005S	11:00	1.12
005S	11:15	1.12
005S	11:30	1.12
005S	11:45	1.12
005S	12:00	0
100C	0:00	0
100C	0:10	6.05
100C	0:20	7.54
100C	0:30	10.16
100C	0:40	15.97
100C	0:50	40.65

100C	1:00	178.56
100C	1:10	54.05
100C	1:20	27.32
100C	1:30	18.24
100C	1:40	13.74
100C	1:50	11.06
100C	2:00	9.29
100C	2:10	8.02
100C	2:20	7.08
100C	2:30	6.35
100C	2:40	5.76
100C	2:50	5.28
100C	3:00	4.88

100S	0:00	2.35
100S	0:15	2.35
100S	0:30	2.35
100S	0:45	2.35
100S	1:00	2.35
100S	1:15	2.35
100S	1:30	2.35
100S	1:45	2.35
100S	2:00	2.82
100S	2:15	2.82
100S	2:30	2.82
100S	2:45	2.82
100S	3:00	3.76
100S	3:15	3.76
100S	3:30	3.76
100S	3:45	3.76
100S	4:00	5.63
100S	4:15	5.63
100S	4:30	7.51
100S	4:45	7.51
100S	5:00	11.27
100S	5:15	11.27
100S	5:30	45.07
100S	5:45	123.95
100S	6:00	16.90

100S	6:15	16.90
100S	6:30	7.51
100S	6:45	7.51
100S	7:00	5.63
100S	7:15	5.63
100S	7:30	5.63
100S	7:45	5.63
100S	8:00	3.29
100S	8:15	3.29
100S	8:30	3.29
100S	8:45	3.29
100S	9:00	3.29
100S	9:15	3.29
100S	9:30	3.29
100S	9:45	3.29
100S	10:00	1.88
100S	10:15	1.88
100S	10:30	1.88
100S	10:45	1.88
100S	11:00	1.88
100S	11:15	1.88
100S	11:30	1.88
100S	11:45	1.88
100S	12:00	0

120C	0:00	0
120C	0:10	7.26
120C	0:20	9.048
120C	0:30	12.192
120C	0:40	19.164
120C	0:50	48.78
120C	1:00	214.272
120C	1:10	64.86
120C	1:20	32.784
120C	1:30	21.888
120C	1:40	16.488
120C	1:50	13.272
120C	2:00	11.148
120C	2:10	9.624

120C	2:20	8.496
120C	2:30	7.62
120C	2:40	6.912
120C	2:50	6.336
120C	3:00	5.856
120S	0:00	2.82
120S	0:15	2.82
120S	0:30	2.82
120S	0:45	2.82
120S	1:00	2.82
120S	1:15	2.82
120S	1:30	2.82
120S	1:45	2.82
120S	2:00	3.38
120S	2:15	3.38
120S	2:30	3.38
120S	2:45	3.38
120S	3:00	4.51
120S	3:15	4.51
120S	3:30	4.51
120S	3:45	4.51
120S	4:00	6.76
120S	4:15	6.76
120S	4:30	9.01
120S	4:45	9.01
120S	5:00	13.52
120S	5:15	13.52
120S	5:30	54.09
120S	5:45	148.74
120S	6:00	20.28
120S	6:15	20.28
120S	6:30	9.01
120S	6:45	9.01
120S	7:00	6.76
120S	7:15	6.76
120S	7:30	6.76
120S	7:45	6.76
120S	8:00	3.94

120S	8:15	3.94
120S	8:30	3.94
120S	8:45	3.94
120S	9:00	3.94
120S	9:15	3.94
120S	9:30	3.94
120S	9:45	3.94
120S	10:00	2.25
120S	10:15	2.25
120S	10:30	2.25
120S	10:45	2.25
120S	11:00	2.25
120S	11:15	2.25
120S	11:30	2.25
120S	11:45	2.25
120S	12:00	0
25.0mm	0:10	1.516088055
25.0mm	0:20	1.749115351
25.0mm	0:30	2.078715445
25.0mm	0:40	2.583625152
25.0mm	0:50	3.461716789
25.0mm	1:00	5.394996968
25.0mm	1:10	13.44811663
25.0mm	1:20	56.72433275
25.0mm	1:30	17.78358976
25.0mm	1:40	9.131254948
25.0mm	1:50	6.147712357
25.0mm	2:00	4.655383456
25.0mm	2:10	3.762897479
25.0mm	2:20	3.169361772
25.0mm	2:30	2.745825503
25.0mm	2:40	2.428071751
25.0mm	2:50	2.180598417
25.0mm	3:00	1.982179574
25.0mm	3:10	1.819403154
25.0mm	3:20	1.683310546
25.0mm	3:30	1.567742242
25.0mm	3:40	1.468311255

25.0mm	3:50	1.381797508
25.0mm	4:00	1.305793328
39.2mm	0:10	2.374535876
39.2mm	0:20	2.739509186
39.2mm	0:30	3.255737280
39.2mm	0:40	4.046539773
39.2mm	0:50	5.421829347
39.2mm	1:00	8.449782195
39.2mm	1:10	21.06278412
39.2mm	1:20	88.84310033
39.2mm	1:30	27.85311299
39.2mm	1:40	14.30160498
39.2mm	1:50	9.628704284
39.2mm	2:00	7.291380602
39.2mm	2:10	5.893546245
39.2mm	2:20	4.963935444
39.2mm	2:30	4.300582110
39.2mm	2:40	3.802908059
39.2mm	2:50	3.415308996
39.2mm	3:00	3.104540331
39.2mm	3:10	2.849595740
39.2mm	3:20	2.636444017
39.2mm	3:30	2.455437985
39.2mm	3:40	2.299706631
39.2mm	3:50	2.164206588
39.2mm	4:00	2.045166898

```
[REPORT]
;;Reporting Options
INPUT      YES
CONTROLS   NO
SUBCATCHMENTS ALL
NODES ALL
LINKS ALL
```

```
[TAGS]
```

```
[MAP]
```

DIMENSIONS	360703.57265	5025681.36685	360885.96035	5025849.29615
UNITS	Meters			

```
[COORDINATES]
```

```
;;Node      X-Coord      Y-Coord
;;-----
EX-STRM     360728.2      5025689
OF-LID1     360712.971    5025788.325
OF-LID2     360803.756    5025841.663
100         360775.8      5025731.7
101         360781.3      5025747.1
102         360759.6      5025766.5
103         360780.1      5025789.7
CB1         360811.792    5025749.2
IRR-TANK    360788.68     5025792.557
IRR-TANK2   360775.727    5025793.437
L102A-S     360766.818    5025755.412
L103A-S     360758.953    5025775.733
LID1A       360736.725    5025763.507
LID1B       360727.862    5025772.37
LID1C       360718.289    5025783.184
LID2        360862.348    5025782.86
LID3        360810.525    5025835.74
LID3-U      360856.836    5025795.863
ROOF1-S     360790.43     5025765.938
ROOF2A-S    360783.025    5025798.036
ROOF2B-S    360764.201    5025795.763
ROOF3-S     360826.389    5025808.031
TANK        360775.8      5025741.2
```

```
[VERTICES]
```

```
;;Link      X-Coord      Y-Coord
;;-----
W2          360771.874    5025738.377
W3          360798.255    5025774.754
LID3A-O     360821.224    5025786.28
```

```
[POLYGONS]
```

```
;;Subcatchment X-Coord      Y-Coord
```

```

;;-----
CB-1      360847.892      5025767.8
CB-1      360850.504      5025764.573
CB-1      360850.504      5025764.573
CB-1      360790.952      5025726.18
CB-1      360790.952      5025726.18
CB-1      360786.342      5025735.572
CB-1      360786.342      5025735.572
CB-1      360789.33       5025737.6
CB-1      360789.33       5025737.6
CB-1      360789.449      5025737.488
CB-1      360792.965      5025739.985
CB-1      360795.054      5025742.066
CB-1      360795.054      5025742.066
CB-1      360800.4         5025748.113
CB-1      360800.4         5025748.113
CB-1      360802.024      5025746.683
CB-1      360802.024      5025746.683
CB-1      360806.254      5025751.484
CB-1      360806.254      5025751.484
CB-1      360807.657      5025750.246
CB-1      360807.657      5025750.246
CB-1      360811.065      5025754.118
CB-1      360811.065      5025754.118
CB-1      360812.26       5025755.475
CB-1      360812.26       5025755.475
CB-1      360813.092      5025754.731
CB-1      360813.092      5025754.731
CB-1      360817.823      5025760.09
CB-1      360817.823      5025760.09
CB-1      360819.48       5025764.702
CB-1      360819.48       5025764.702
CB-1      360820.671      5025766.049
CB-1      360820.671      5025766.049
CB-1      360824.84       5025770.642
CB-1      360824.84       5025770.642
CB-1      360828.245      5025771.751
CB-1      360828.245      5025771.751
CB-1      360831.063      5025771.931

```

```

CB-1      360831.063      5025771.931
CB-1      360837.174      5025778.859
CB-1      360837.174      5025778.859
CB-1      360838.651      5025779.382
CB-1      360838.651      5025779.382
CB-1      360838.662      5025779.386
CB-1      360838.662      5025779.386
CB-1      360839.966      5025774.929
CB-1      360839.966      5025774.929
CB-1      360844.832      5025770.628
CB-1      360844.832      5025770.628
CB-1      360847.892      5025767.8
CB-2      360785.068      5025797.51
CB-2      360774.783      5025815.591
CB-2      360774.783      5025815.591
CB-2      360777.539      5025817.25
CB-2      360777.539      5025817.25
CB-2      360775.087      5025819.359
CB-2      360775.087      5025819.359
CB-2      360777.754      5025820.87
CB-2      360777.754      5025820.87
CB-2      360787.054      5025813.346
CB-2      360787.054      5025813.346
CB-2      360791.761      5025818.852
CB-2      360791.761      5025818.852
CB-2      360802.562      5025809.399
CB-2      360802.562      5025809.399
CB-2      360803.557      5025810.524
CB-2      360803.557      5025810.524
CB-2      360808.292      5025806.352
CB-2      360808.292      5025806.352
CB-2      360799.694      5025796.787
CB-2      360799.694      5025796.787
CB-2      360797.485      5025794.449
CB-2      360788.027      5025796.109
CB-2      360785.068      5025797.51
DRN2A     360780.116      5025781.568
DRN2A     360774.542      5025791.367
DRN2A     360774.542      5025791.367

```

DRN2A	360780.052	5025794.501
DRN2A	360780.052	5025794.501
DRN2A	360785.068	5025797.51
DRN2A	360785.068	5025797.51
DRN2A	360788.027	5025796.109
DRN2A	360797.485	5025794.449
DRN2A	360799.694	5025796.787
DRN2A	360799.694	5025796.787
DRN2A	360808.292	5025806.352
DRN2A	360808.292	5025806.352
DRN2A	360809.194	5025805.553
DRN2A	360809.194	5025805.553
DRN2A	360809.188	5025805.546
DRN2A	360809.188	5025805.546
DRN2A	360809.194	5025805.553
DRN2A	360809.194	5025805.553
DRN2A	360815.454	5025800.01
DRN2A	360815.454	5025800.01
DRN2A	360800.892	5025783.531
DRN2A	360800.892	5025783.531
DRN2A	360799.665	5025782.213
DRN2A	360799.665	5025782.213
DRN2A	360796.609	5025778.77
DRN2A	360796.609	5025778.77
DRN2A	360788.172	5025786.199
DRN2A	360788.172	5025786.199
DRN2A	360782.361	5025779.593
DRN2A	360782.361	5025779.593
DRN2A	360780.116	5025781.568
DRN2B	360815.454	5025800.01
DRN2B	360838.651	5025779.382
DRN2B	360838.651	5025779.382
DRN2B	360837.174	5025778.859
DRN2B	360837.174	5025778.859
DRN2B	360831.063	5025771.931
DRN2B	360831.063	5025771.931
DRN2B	360828.245	5025771.751
DRN2B	360828.245	5025771.751
DRN2B	360824.84	5025770.642

DRN2B	360824.84	5025770.642
DRN2B	360820.671	5025766.049
DRN2B	360820.671	5025766.049
DRN2B	360819.48	5025764.702
DRN2B	360819.48	5025764.702
DRN2B	360817.823	5025760.09
DRN2B	360817.823	5025760.09
DRN2B	360796.609	5025778.77
DRN2B	360796.609	5025778.77
DRN2B	360799.665	5025782.213
DRN2B	360799.665	5025782.213
DRN2B	360800.892	5025783.531
DRN2B	360800.892	5025783.531
DRN2B	360815.454	5025800.01
GRN-1	360782.361	5025779.593
GRN-1	360788.172	5025786.199
GRN-1	360788.172	5025786.199
GRN-1	360796.609	5025778.77
GRN-1	360796.609	5025778.77
GRN-1	360796.584	5025778.742
GRN-1	360796.584	5025778.742
GRN-1	360796.609	5025778.77
GRN-1	360796.609	5025778.77
GRN-1	360817.823	5025760.09
GRN-1	360817.823	5025760.09
GRN-1	360813.092	5025754.731
GRN-1	360813.092	5025754.731
GRN-1	360812.26	5025755.475
GRN-1	360812.26	5025755.475
GRN-1	360811.065	5025754.118
GRN-1	360811.065	5025754.118
GRN-1	360805.776	5025758.774
GRN-1	360805.776	5025758.774
GRN-1	360807.538	5025760.763
GRN-1	360807.538	5025760.763
GRN-1	360787.661	5025778.266
GRN-1	360787.661	5025778.266
GRN-1	360785.9	5025776.269
GRN-1	360785.9	5025776.269

GRN-1	360782.361	5025779.593
GRN-2	360780.052	5025794.501
GRN-2	360744.668	5025774.373
GRN-2	360744.668	5025774.373
GRN-2	360735.577	5025790.359
GRN-2	360735.577	5025790.359
GRN-2	360735.047	5025790.057
GRN-2	360735.047	5025790.057
GRN-2	360734.775	5025790.536
GRN-2	360734.775	5025790.536
GRN-2	360770.687	5025810.963
GRN-2	360770.687	5025810.963
GRN-2	360780.052	5025794.501
GRN-3	360815.454	5025800.01
GRN-3	360809.194	5025805.553
GRN-3	360809.194	5025805.553
GRN-3	360815.314	5025812.494
GRN-3	360815.314	5025812.494
GRN-3	360820.358	5025808.04
GRN-3	360820.358	5025808.04
GRN-3	360816.846	5025803.969
GRN-3	360816.846	5025803.969
GRN-3	360839.136	5025784.38
GRN-3	360839.136	5025784.38
GRN-3	360843.282	5025789.082
GRN-3	360843.282	5025789.082
GRN-3	360845.559	5025787.075
GRN-3	360845.559	5025787.075
GRN-3	360838.651	5025779.382
GRN-3	360838.651	5025779.382
GRN-3	360815.454	5025800.01
L102A	360772.398	5025772.821
L102A	360795.556	5025752.387
L102A	360795.556	5025752.387
L102A	360793.302	5025749.798
L102A	360793.302	5025749.798
L102A	360787.47	5025743.961
L102A	360787.47	5025743.961
L102A	360786.245	5025742.972

L102A	360786.245	5025742.972
L102A	360789.33	5025737.6
L102A	360789.33	5025737.6
L102A	360786.342	5025735.572
L102A	360786.342	5025735.572
L102A	360790.952	5025726.18
L102A	360790.952	5025726.18
L102A	360774.766	5025715.471
L102A	360774.766	5025715.471
L102A	360763.936	5025727.179
L102A	360763.936	5025727.179
L102A	360768.837	5025731.822
L102A	360768.837	5025731.822
L102A	360769.26	5025734.51
L102A	360769.26	5025734.51
L102A	360768.863	5025738.047
L102A	360768.863	5025738.047
L102A	360754.399	5025763.505
L102A	360754.399	5025763.505
L102A	360772.398	5025772.821
L103A	360740.15	5025771.959
L103A	360744.668	5025774.373
L103A	360744.668	5025774.373
L103A	360774.542	5025791.367
L103A	360774.542	5025791.367
L103A	360780.116	5025781.568
L103A	360780.116	5025781.568
L103A	360772.398	5025772.821
L103A	360772.398	5025772.821
L103A	360754.399	5025763.505
L103A	360754.399	5025763.505
L103A	360754.349	5025763.593
L103A	360754.349	5025763.593
L103A	360751.234	5025766.014
L103A	360751.234	5025766.014
L103A	360746.139	5025765.543
L103A	360746.139	5025765.543
L103A	360745.222	5025765.204
L103A	360745.222	5025765.204

L103A	360744.211	5025765.349
L103A	360744.211	5025765.349
L103A	360743.255	5025766.095
L103A	360743.255	5025766.095
L103A	360740.15	5025771.959
LID-1	360711.863	5025783.54
LID-1	360775.087	5025819.359
LID-1	360775.087	5025819.359
LID-1	360777.539	5025817.25
LID-1	360777.539	5025817.25
LID-1	360774.783	5025815.591
LID-1	360774.783	5025815.591
LID-1	360726.152	5025787.928
LID-1	360726.152	5025787.928
LID-1	360736.437	5025769.847
LID-1	360736.437	5025769.847
LID-1	360740.15	5025771.959
LID-1	360740.15	5025771.959
LID-1	360743.255	5025766.095
LID-1	360743.255	5025766.095
LID-1	360744.211	5025765.349
LID-1	360744.211	5025765.349
LID-1	360745.222	5025765.204
LID-1	360745.222	5025765.204
LID-1	360746.139	5025765.543
LID-1	360746.139	5025765.543
LID-1	360751.234	5025766.014
LID-1	360751.234	5025766.014
LID-1	360754.349	5025763.593
LID-1	360754.349	5025763.593
LID-1	360754.399	5025763.505
LID-1	360754.399	5025763.505
LID-1	360754.214	5025763.409
LID-1	360754.214	5025763.409
LID-1	360754.399	5025763.505
LID-1	360754.399	5025763.505
LID-1	360768.863	5025738.047
LID-1	360768.863	5025738.047
LID-1	360769.26	5025734.51

LID-1	360769.26	5025734.51
LID-1	360768.837	5025731.822
LID-1	360768.837	5025731.822
LID-1	360763.936	5025727.179
LID-1	360763.936	5025727.179
LID-1	360711.863	5025783.54
LID-2	360854.46	5025792.634
LID-2	360863.387	5025794.677
LID-2	360863.387	5025794.677
LID-2	360877.67	5025782.093
LID-2	360877.67	5025782.093
LID-2	360850.504	5025764.573
LID-2	360850.504	5025764.573
LID-2	360847.892	5025767.8
LID-2	360847.892	5025767.8
LID-2	360844.832	5025770.628
LID-2	360844.832	5025770.628
LID-2	360839.966	5025774.929
LID-2	360839.966	5025774.929
LID-2	360838.662	5025779.386
LID-2	360838.662	5025779.386
LID-2	360838.651	5025779.382
LID-2	360838.651	5025779.382
LID-2	360845.559	5025787.075
LID-2	360845.559	5025787.075
LID-2	360845.563	5025787.071
LID-2	360845.563	5025787.071
LID-2	360845.559	5025787.075
LID-2	360845.559	5025787.075
LID-2	360845.932	5025787.49
LID-2	360845.932	5025787.49
LID-2	360848.203	5025785.541
LID-2	360848.203	5025785.541
LID-2	360854.46	5025792.634
LID-3	360854.46	5025792.634
LID-3	360810.226	5025831.443
LID-3	360810.226	5025831.443
LID-3	360803.082	5025823.267
LID-3	360803.082	5025823.267

LID-3	360800.822	5025825.284
LID-3	360800.822	5025825.284
LID-3	360794.621	5025818.2
LID-3	360794.621	5025818.2
LID-3	360803.557	5025810.524
LID-3	360803.557	5025810.524
LID-3	360802.562	5025809.399
LID-3	360802.562	5025809.399
LID-3	360791.761	5025818.852
LID-3	360791.761	5025818.852
LID-3	360787.054	5025813.346
LID-3	360787.054	5025813.346
LID-3	360777.754	5025820.87
LID-3	360777.754	5025820.87
LID-3	360811.824	5025840.172
LID-3	360811.824	5025840.172
LID-3	360863.387	5025794.677
LID-3	360863.387	5025794.677
LID-3	360854.46	5025792.634
RAMP	360795.556	5025752.387
RAMP	360800.4	5025748.113
RAMP	360800.4	5025748.113
RAMP	360795.054	5025742.066
RAMP	360795.054	5025742.066
RAMP	360792.965	5025739.985
RAMP	360789.449	5025737.488
RAMP	360789.33	5025737.6
RAMP	360789.33	5025737.6
RAMP	360786.245	5025742.972
RAMP	360786.245	5025742.972
RAMP	360787.47	5025743.961
RAMP	360787.47	5025743.961
RAMP	360793.302	5025749.798
RAMP	360793.302	5025749.798
RAMP	360795.556	5025752.387
ROOF-1	360780.116	5025781.568
ROOF-1	360782.361	5025779.593
ROOF-1	360782.361	5025779.593
ROOF-1	360785.9	5025776.269

ROOF-1	360785.9	5025776.269
ROOF-1	360787.661	5025778.266
ROOF-1	360787.661	5025778.266
ROOF-1	360807.538	5025760.763
ROOF-1	360807.538	5025760.763
ROOF-1	360805.776	5025758.774
ROOF-1	360805.776	5025758.774
ROOF-1	360811.065	5025754.118
ROOF-1	360811.065	5025754.118
ROOF-1	360807.657	5025750.246
ROOF-1	360807.657	5025750.246
ROOF-1	360806.254	5025751.484
ROOF-1	360806.254	5025751.484
ROOF-1	360802.024	5025746.683
ROOF-1	360802.024	5025746.683
ROOF-1	360800.4	5025748.113
ROOF-1	360800.4	5025748.113
ROOF-1	360795.556	5025752.387
ROOF-1	360795.556	5025752.387
ROOF-1	360795.635	5025752.477
ROOF-1	360795.635	5025752.477
ROOF-1	360795.556	5025752.387
ROOF-1	360795.556	5025752.387
ROOF-1	360772.398	5025772.821
ROOF-1	360772.398	5025772.821
ROOF-1	360780.116	5025781.568
ROOF-2A	360726.152	5025787.928
ROOF-2A	360774.783	5025815.591
ROOF-2A	360774.783	5025815.591
ROOF-2A	360785.068	5025797.51
ROOF-2A	360785.068	5025797.51
ROOF-2A	360780.052	5025794.501
ROOF-2A	360780.052	5025794.501
ROOF-2A	360770.687	5025810.963
ROOF-2A	360770.687	5025810.963
ROOF-2A	360734.775	5025790.536
ROOF-2A	360734.775	5025790.536
ROOF-2A	360735.047	5025790.057
ROOF-2A	360735.047	5025790.057

ROOF-2A	360735.577	5025790.359
ROOF-2A	360735.577	5025790.359
ROOF-2A	360744.668	5025774.373
ROOF-2A	360744.668	5025774.373
ROOF-2A	360740.15	5025771.959
ROOF-2A	360740.15	5025771.959
ROOF-2A	360736.437	5025769.847
ROOF-2A	360736.437	5025769.847
ROOF-2A	360726.152	5025787.928
ROOF-2B	360756.489	5025787.32
ROOF-2B	360753.563	5025792.509
ROOF-2B	360753.563	5025792.509
ROOF-2B	360771.268	5025802.491
ROOF-2B	360771.268	5025802.491
ROOF-2B	360774.194	5025797.302
ROOF-2B	360774.194	5025797.302
ROOF-2B	360756.489	5025787.32
ROOF-3	360810.226	5025831.443
ROOF-3	360854.46	5025792.634
ROOF-3	360854.46	5025792.634
ROOF-3	360848.203	5025785.541
ROOF-3	360848.203	5025785.541
ROOF-3	360845.932	5025787.49
ROOF-3	360845.932	5025787.49
ROOF-3	360845.559	5025787.075
ROOF-3	360845.559	5025787.075
ROOF-3	360843.282	5025789.082
ROOF-3	360843.282	5025789.082
ROOF-3	360839.136	5025784.38
ROOF-3	360839.136	5025784.38
ROOF-3	360816.846	5025803.969
ROOF-3	360816.846	5025803.969
ROOF-3	360820.358	5025808.04
ROOF-3	360820.358	5025808.04
ROOF-3	360815.314	5025812.494
ROOF-3	360815.314	5025812.494
ROOF-3	360809.194	5025805.553
ROOF-3	360809.194	5025805.553
ROOF-3	360808.292	5025806.352

ROOF-3	360808.292	5025806.352
ROOF-3	360803.557	5025810.524
ROOF-3	360803.557	5025810.524
ROOF-3	360794.621	5025818.2
ROOF-3	360794.621	5025818.2
ROOF-3	360800.822	5025825.284
ROOF-3	360800.822	5025825.284
ROOF-3	360803.082	5025823.267
ROOF-3	360803.082	5025823.267
ROOF-3	360810.226	5025831.443

```
;;Storage Node X-Coord Y-Coord
;;-----
```

```
[SYMBOLS]
;;Gage X-Coord Y-Coord
;;-----
```

EPA STORM WATER MANAGEMENT MODEL - VERSION 5.2 (Build 5.2.4)

Element Count

Number of rain gages 2
 Number of subcatchments ... 17
 Number of nodes 23
 Number of links 22
 Number of pollutants 0
 Number of land uses 0

Raingage Summary

Name	Data Source	Data Type	Recording Interval
RG-C	100C	INTENSITY	10 min.
RG-S	100S	INTENSITY	15 min.

Subcatchment Summary

Name	Area	Width	%Imperv	%Slope	Rain Gage	Outlet
CB-1	0.10	121.00	100.00	3.0000	RG-C	CB1
CB-2	0.05	33.00	85.71	3.0000	RG-C	103
DRN2A	0.05	41.00	100.00	3.0000	RG-C	103
DRN2B	0.08	27.00	71.43	3.0000	RG-C	103
GRN-1	0.03	6.32	14.29	2.0000	RG-C	103
GRN-2	0.07	14.63	14.29	2.0000	RG-C	103
GRN-3	0.02	4.76	14.29	2.0000	RG-C	103

L102A	0.12	51.00	80.00	3.0000	RG-C	L102A-S
L103A	0.05	40.00	100.00	3.0000	RG-C	L103A-S
LID-1	0.12	26.10	8.57	3.0000	RG-C	LID1A
LID-2	0.06	39.00	42.86	3.0000	RG-C	LID2
LID-3	0.08	103.00	14.29	3.0000	RG-C	LID3-U
RAMP	0.01	15.00	100.00	15.0000	RG-C	103
ROOF-1	0.05	12.07	100.00	2.0000	RG-C	ROOF1-S
ROOF-2A	0.04	8.97	100.00	2.0000	RG-C	ROOF2A-S
ROOF-2B	0.01	2.72	100.00	2.0000	RG-C	ROOF2B-S
ROOF-3	0.10	21.91	100.00	2.0000	RG-C	ROOF3-S

Node Summary

Name	Type	Invert Elev.	Max. Depth	Ponded Area	External Inflow
EX-STRM	OUTFALL	63.05	0.30	0.0	
OF-LID1	OUTFALL	62.25	0.00	0.0	
OF-LID2	OUTFALL	63.33	0.00	0.0	
100	STORAGE	63.43	1.76	0.0	
101	STORAGE	63.67	1.57	0.0	
102	STORAGE	63.79	1.47	0.0	
103	STORAGE	63.90	1.33	0.0	
CB1	STORAGE	63.72	1.78	0.0	
IRR-TANK	STORAGE	80.00	1.30	0.0	
IRR-TANK2	STORAGE	80.00	1.30	0.0	
L102A-S	STORAGE	63.95	1.41	0.0	
L103A-S	STORAGE	64.03	1.30	0.0	
LID1A	STORAGE	63.09	0.45	0.0	
LID1B	STORAGE	62.58	0.46	0.0	
LID1C	STORAGE	62.00	0.45	0.0	
LID2	STORAGE	64.85	0.50	0.0	
LID3	STORAGE	63.10	0.80	0.0	
LID3-U	STORAGE	65.22	0.13	0.0	
ROOF1-S	STORAGE	100.00	0.15	0.0	
ROOF2A-S	STORAGE	100.00	0.15	0.0	
ROOF2B-S	STORAGE	100.00	0.15	0.0	

ROOF3-S	STORAGE	100.00	0.15	0.0
TANK	STORAGE	62.50	2.50	0.0

Link Summary

Name	From Node	To Node	Type	Length	%Slope	Roughness
100--EX	100	EX-STRM	CONDUIT	63.9	0.5947	0.0130
101-TANK	101	TANK	CONDUIT	8.1	0.2469	0.0130
102-101	102	101	CONDUIT	29.1	0.2062	0.0130
103-102	103	102	CONDUIT	31.0	0.1935	0.0130
LID2-U--LID2	LID3-U	LID3	CONDUIT	55.3	2.7497	0.0350
OR1	CB1	103	TYPE4 PUMP			
IRR-TANK2-O	IRR-TANK2	103	ORIFICE			
IRR-TANK-O	IRR-TANK	103	ORIFICE			
L102A-O	L102A-S	102	ORIFICE			
L103A-O	L103A-S	102	ORIFICE			
TANK--100	TANK	100	ORIFICE			
MJ-LID1B	LID1A	LID1B	WEIR			
MJ-LID1C	LID1B	LID1C	WEIR			
MJ-OF-LID1	LID1C	OF-LID1	WEIR			
MJ-OF-LID2	LID3	OF-LID2	WEIR			
W2	TANK	100	WEIR			
W3	CB1	103	WEIR			
LID3A-O	LID2	103	OUTLET			
ROOF1-O	ROOF1-S	IRR-TANK	OUTLET			
ROOF2A-O	ROOF2A-S	IRR-TANK2	OUTLET			
ROOF2B-O	ROOF2B-S	IRR-TANK2	OUTLET			
ROOF3-O	ROOF3-S	IRR-TANK	OUTLET			

Cross Section Summary

Conduit	Shape	Full Depth	Full Area	Hyd. Rad.	Max. Width	No. of Barrels	Full Flow
---------	-------	------------	-----------	-----------	------------	----------------	-----------

100--EX	CIRCULAR	0.30	0.07	0.07	0.30	1	74.58
101-TANK	CIRCULAR	0.45	0.16	0.11	0.45	1	141.68
102-101	CIRCULAR	0.45	0.16	0.11	0.45	1	129.47
103-102	CIRCULAR	0.45	0.16	0.11	0.45	1	125.44
LID2-U--LID2	TRIANGULAR	0.20	0.20	0.10	2.00	1	201.50

Analysis Options

Flow Units LPS
Process Models:
 Rainfall/Runoff YES
 RDII NO
 Snowmelt NO
 Groundwater NO
 Flow Routing YES
 Ponding Allowed NO
 Water Quality NO
Infiltration Method HORTON
Flow Routing Method DYNWAVE
Surcharge Method EXTRAN
Starting Date 03/07/2024 00:00:00
Ending Date 03/08/2024 00:00:00
Antecedent Dry Days 0.0
Report Time Step 00:01:00
Wet Time Step 00:01:00
Dry Time Step 00:01:00
Routing Time Step 1.00 sec
Variable Time Step NO
Maximum Trials 8
Number of Threads 1
Head Tolerance 0.001500 m

*****	Volume	Depth
Runoff Quantity Continuity	hectare-m	mm
*****	-----	-----
Total Precipitation	0.074	71.667

```

Evaporation Loss ..... 0.000 0.000
Infiltration Loss ..... 0.017 16.041
Surface Runoff ..... 0.057 54.686
Final Storage ..... 0.001 1.019
Continuity Error (%) ..... -0.110

```

```

*****
Volume Volume
Flow Routing Continuity hectare-m 10^6 ltr
*****
Dry Weather Inflow ..... 0.000 0.000
Wet Weather Inflow ..... 0.057 0.566
Groundwater Inflow ..... 0.000 0.000
RDII Inflow ..... 0.000 0.000
External Inflow ..... 0.000 0.000
External Outflow ..... 0.041 0.409
Flooding Loss ..... 0.000 0.000
Evaporation Loss ..... 0.000 0.000
Exfiltration Loss ..... 0.000 0.000
Initial Stored Volume .... 0.013 0.134
Final Stored Volume ..... 0.029 0.291
Continuity Error (%) ..... -0.025

```

```

*****
Highest Flow Instability Indexes
*****
All links are stable.

```

```

*****
Most Frequent Nonconverging Nodes
*****
Convergence obtained at all time steps.

```

```

*****
Routing Time Step Summary
*****

```

```

Minimum Time Step : 1.00 sec
Average Time Step : 1.00 sec
Maximum Time Step : 1.00 sec
% of Time in Steady State : 0.00
Average Iterations per Step : 2.00
% of Steps Not Converging : 0.00

```

```

*****
Subcatchment Runoff Summary
*****

```

			Total	Total	Total	Total	Imperv	Perv	Total	
Total	Peak	Runoff	Precip	Runon	Evap	Infil	Runoff	Runoff	Runoff	
Runoff	Runoff	Coeff	mm	mm	mm	mm	mm	mm	mm	10^6
Subcatchment	LPS									
ltr										
CB-1			71.67	0.00	0.00	0.00	70.22	0.00	70.22	
0.07	48.49	0.980								
CB-2			71.67	0.00	0.00	6.26	60.18	4.00	64.18	
0.03	22.69	0.896								
DRN2A			71.67	0.00	0.00	0.00	70.21	0.00	70.21	
0.03	24.18	0.980								
DRN2B			71.67	0.00	0.00	12.68	50.14	7.82	57.96	
0.05	37.17	0.809								
GRN-1			71.67	0.00	0.00	40.30	10.03	21.14	31.17	
0.01	6.02	0.435								
GRN-2			71.67	0.00	0.00	40.30	10.03	21.14	31.17	
0.02	13.94	0.435								
GRN-3			71.67	0.00	0.00	40.30	10.03	21.14	31.17	
0.01	4.53	0.435								
L102A			71.67	0.00	0.00	8.82	56.16	5.54	61.70	

0.08	59.13	0.861							
L103A			71.67	0.00	0.00	0.00	70.21	0.00	70.21
0.04	25.90	0.980							
LID-1			71.67	0.00	0.00	42.65	6.01	22.89	28.91
0.03	24.51	0.403							
LID-2			71.67	0.00	0.00	25.39	30.09	15.60	45.69
0.03	26.72	0.638							
LID-3			71.67	0.00	0.00	37.91	10.02	23.58	33.60
0.03	33.20	0.469							
RAMP			71.67	0.00	0.00	0.00	70.16	0.00	70.16
0.01	4.65	0.979							
ROOF-1			71.67	0.00	0.00	0.00	70.16	0.00	70.16
0.04	26.60	0.979							
ROOF-2A			71.67	0.00	0.00	0.00	70.16	0.00	70.16
0.03	19.77	0.979							
ROOF-2B			71.67	0.00	0.00	0.00	70.16	0.00	70.16
0.01	6.00	0.979							
ROOF-3			71.67	0.00	0.00	0.00	70.16	0.00	70.16
0.07	48.28	0.979							

Node Depth Summary

Node	Type	Average Depth Meters	Maximum Depth Meters	Maximum HGL Meters	Time of Max Occurrence days hr:min	Reported Max Depth Meters
EX-STRM	OUTFALL	0.02	0.24	63.29	0 01:22	0.24
OF-LID1	OUTFALL	0.00	0.00	62.25	0 00:00	0.00
OF-LID2	OUTFALL	0.00	0.00	63.33	0 00:00	0.00
100	STORAGE	0.03	0.44	63.87	0 01:22	0.43
101	STORAGE	0.02	0.44	64.11	0 01:22	0.44
102	STORAGE	0.03	0.54	64.33	0 01:10	0.54
103	STORAGE	0.02	0.59	64.49	0 01:10	0.59
CB1	STORAGE	0.05	1.54	65.26	0 01:10	1.54
IRR-TANK	STORAGE	0.95	1.07	81.07	0 02:12	1.07

IRR-TANK2	STORAGE	0.93	1.04	81.04	0 03:07	1.04
L102A-S	STORAGE	0.04	1.16	65.11	0 01:12	1.16
L103A-S	STORAGE	0.03	1.13	65.16	0 01:10	1.13
LID1A	STORAGE	0.34	0.39	63.48	0 01:16	0.39
LID1B	STORAGE	0.34	0.39	62.97	0 01:29	0.39
LID1C	STORAGE	0.28	0.30	62.30	0 23:27	0.30
LID2	STORAGE	0.19	0.27	65.12	0 01:10	0.27
LID3	STORAGE	0.61	0.64	63.74	1 00:00	0.64
LID3-U	STORAGE	0.00	0.10	65.32	0 01:10	0.10
ROOF1-S	STORAGE	0.01	0.13	100.13	0 01:20	0.13
ROOF2A-S	STORAGE	0.01	0.14	100.14	0 01:27	0.14
ROOF2B-S	STORAGE	0.00	0.12	100.12	0 01:16	0.12
ROOF3-S	STORAGE	0.02	0.14	100.14	0 01:31	0.14
TANK	STORAGE	1.03	1.60	64.10	0 01:21	1.60

Node Inflow Summary

Node	Type	Maximum Lateral Inflow LPS	Maximum Total Inflow LPS	Time of Max Occurrence days hr:min	Lateral Inflow Volume 10^6 ltr	Total Inflow Volume 10^6 ltr	Flow Balance Error Percent
EX-STRM	OUTFALL	0.00	92.60	0 01:22	0	0.409	0.000
OF-LID1	OUTFALL	0.00	0.00	0 00:00	0	0	0.000 ltr
OF-LID2	OUTFALL	0.00	0.00	0 00:00	0	0	0.000 ltr
100	STORAGE	0.00	96.41	0 01:20	0	0.409	0.001
101	STORAGE	0.00	184.82	0 01:10	0	0.408	-0.189
102	STORAGE	0.00	186.35	0 01:10	0	0.409	0.229
103	STORAGE	113.17	154.74	0 01:10	0.153	0.297	0.002
CB1	STORAGE	48.49	48.49	0 01:10	0.0686	0.0686	0.015
IRR-TANK	STORAGE	0.00	13.45	0 01:31	0	0.106	0.010
IRR-TANK2	STORAGE	0.00	5.05	0 01:01	0	0.0365	0.014
L102A-S	STORAGE	59.13	59.13	0 01:10	0.0761	0.0761	0.019
L103A-S	STORAGE	25.90	25.90	0 01:10	0.0367	0.0367	0.008
LID1A	STORAGE	24.51	24.51	0 01:10	0.0335	0.0335	0.003

LID1B	STORAGE	0.00	15.89	0	01:16	0	0.0236	0.005
LID1C	STORAGE	0.00	9.09	0	01:29	0	0.0137	0.011
LID2	STORAGE	26.72	26.72	0	01:10	0.0287	0.0287	-0.002
LID3	STORAGE	0.00	31.56	0	01:10	0	0.0271	0.585
LID3-U	STORAGE	33.20	33.20	0	01:10	0.0272	0.0272	0.235
ROOF1-S	STORAGE	26.60	26.60	0	01:10	0.0376	0.0376	-0.005
ROOF2A-S	STORAGE	19.77	19.77	0	01:10	0.028	0.028	-0.003
ROOF2B-S	STORAGE	6.00	6.00	0	01:10	0.0085	0.0085	-0.005
ROOF3-S	STORAGE	48.28	48.28	0	01:10	0.0683	0.0683	-0.002
TANK	STORAGE	0.00	184.89	0	01:10	0	0.543	-0.063

Node Surcharge Summary

No nodes were surcharged.

Node Flooding Summary

No nodes were flooded.

Storage Volume Summary

Storage Unit	Average Volume 1000 m	Avg Pcnt Full	Evap Pcnt Loss	Exfil Pcnt Loss	Maximum Volume 1000 m	Max Pcnt Full	Time of Max Occurrence days hr:min	Maximum Outflow LPS
100	0.000	1.6	0.0	0.0	0.000	24.7	0 01:22	92.60
101	0.000	1.5	0.0	0.0	0.000	27.9	0 01:22	184.89
102	0.000	1.8	0.0	0.0	0.001	37.0	0 01:10	184.82
103	0.000	1.8	0.0	0.0	0.001	44.2	0 01:10	153.57

CB1	0.000	0.3	0.0	0.0	0.015	23.1	0 01:10	22.37
IRR-TANK	0.057	72.8	0.0	0.0	0.064	82.1	0 02:12	7.93
IRR-TANK2	0.028	71.8	0.0	0.0	0.031	79.8	0 03:07	3.32
L102A-S	0.000	0.3	0.0	0.0	0.020	15.6	0 01:12	23.00
L103A-S	0.000	0.2	0.0	0.0	0.007	18.2	0 01:10	13.52
LID1A	0.010	65.2	0.0	0.0	0.012	81.6	0 01:16	15.89
LID1B	0.009	65.4	0.0	0.0	0.011	77.9	0 01:29	9.09
LID1C	0.013	43.5	0.0	0.0	0.014	46.9	0 23:27	0.00
LID2	0.006	24.6	0.0	0.0	0.010	39.6	0 01:10	19.59
LID3	0.025	64.7	0.0	0.0	0.027	68.3	1 00:00	0.00
LID3-U	0.000	0.0	0.0	0.0	0.000	0.0	0 00:00	31.56
ROOF1-S	0.000	1.8	0.0	0.0	0.013	58.9	0 01:20	6.94
ROOF2A-S	0.001	4.4	0.0	0.0	0.013	78.2	0 01:27	3.15
ROOF2B-S	0.000	1.2	0.0	0.0	0.002	50.7	0 01:16	1.89
ROOF3-S	0.003	6.7	0.0	0.0	0.035	89.8	0 01:31	6.51
TANK	0.142	57.5	0.0	0.0	0.247	100.0	0 01:20	96.41

Outfall Loading Summary

Outfall Node	Flow Freq Pcnt	Avg Flow LPS	Max Flow LPS	Total Volume 10^6 ltr
EX-STRM	46.50	10.18	92.60	0.409
OF-LID1	0.00	0.00	0.00	0.000
OF-LID2	0.00	0.00	0.00	0.000
System	15.50	10.18	92.60	0.409

Link Flow Summary

Link	Type	Maximum Flow LPS	Time of Max Occurrence days hr:min	Maximum Veloc m/sec	Max/ Full Flow	Max/ Full Depth
100--EX	CONDUIT	92.60	0 01:22	1.39	1.24	0.89
101-TANK	CONDUIT	184.89	0 01:10	1.54	1.31	0.99
102-101	CONDUIT	184.82	0 01:10	1.30	1.43	0.84
103-102	CONDUIT	153.57	0 01:10	0.97	1.22	1.00
LID2-U--LID2	CONDUIT	31.56	0 01:10	0.65	0.16	0.49
OR1	PUMP	22.37	0 01:10		0.93	
IRR-TANK2-0	ORIFICE	3.32	0 03:07			0.13
IRR-TANK-0	ORIFICE	7.93	0 02:12			0.23
L102A-0	ORIFICE	23.00	0 01:36			1.00
L103A-0	ORIFICE	13.52	0 01:15			1.00
TANK--100	ORIFICE	96.41	0 01:20			1.00
MJ-LID1B	WEIR	15.89	0 01:16			0.45
MJ-LID1C	WEIR	9.09	0 01:29			0.31
MJ-OF-LID1	WEIR	0.00	0 00:00			0.00
MJ-OF-LID2	WEIR	0.00	0 00:00			0.00
W2	WEIR	0.00	0 00:00			0.00
W3	WEIR	0.00	0 00:00			0.00
LID3A-0	DUMMY	19.59	0 01:10			
ROOF1-0	DUMMY	6.94	0 01:01			
ROOF2A-0	DUMMY	3.15	0 00:57			
ROOF2B-0	DUMMY	1.89	0 01:01			
ROOF3-0	DUMMY	6.51	0 01:31			

Flow Classification Summary

Conduit	Adjusted /Actual Length	----- Fraction of Time in Flow Class -----								
		Up Dry	Down Dry	Sub Dry	Sup Crit	Up Crit	Down Crit	Norm Ltd	Inlet Ctrl	
100--EX	1.00	0.02	0.00	0.00	0.57	0.41	0.00	0.00	0.06	0.00
101-TANK	1.00	0.02	0.00	0.00	0.03	0.00	0.00	0.95	0.00	0.00

102-101	1.00	0.02	0.00	0.00	0.02	0.00	0.00	0.96	0.00	0.00
103-102	1.00	0.02	0.00	0.00	0.05	0.00	0.00	0.93	0.00	0.00
LID2-U--LID2	1.00	0.02	0.00	0.00	0.93	0.00	0.00	0.06	0.92	0.00

Conduit Surge Summary

Conduit	----- Both Ends	----- Hours Full -----			Hours Above Full Normal Flow	Hours Capacity Limited
		Upstream	Dnstream			
100--EX	0.01	0.51	0.01	0.61	0.01	
101-TANK	0.01	0.01	0.01	0.13	0.01	
102-101	0.01	0.11	0.01	0.17	0.01	
103-102	0.07	0.10	0.07	0.09	0.07	

Pumping Summary

Pump	Percent Utilized	Number of Start-Ups	Min Flow LPS	Avg Flow LPS	Max Flow LPS	Total Volume 10^6 ltr	Power Usage Kw-hr	% Time Off Pump Curve	
								Low	High
OR1	12.62	1	0.00	6.29	22.37	0.069	0.12	0.0	0.0

Analysis begun on: Thu Nov 28 14:22:09 2024
Analysis ended on: Thu Nov 28 14:22:10 2024
Total elapsed time: 00:00:01

D.3 Excerpts from the SWM Design Criteria for the Pinecrest Creek/Westboro Area (City of Ottawa, May 2020)



**Stormwater Management Design Criteria
for the Pinecrest Creek/Westboro Area**

City of Ottawa
Final – May 2020

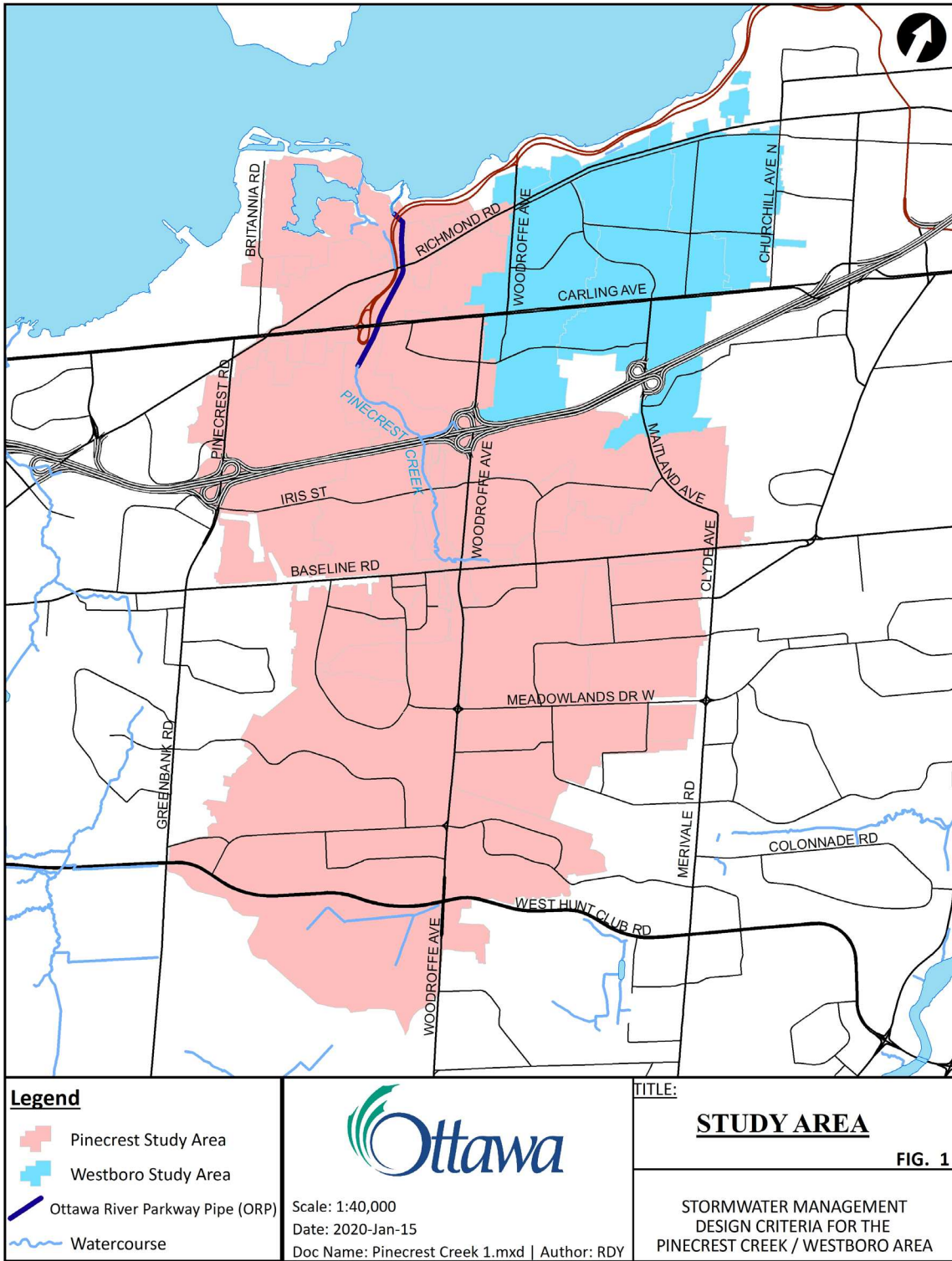

Figure 1: Study Area

Table 1: SWM Design Criteria for the Pinecrest Creek / Westboro Study Area

Development Type		Runoff Volume Reduction	Water Quality	Water Quantity	
			TSS Removal	Flood Control	Erosion Control
All Locations					
Residential Development <u>not</u> subject to Plan of Subdivision or Site Plan Control approval(s)					
1	all soil infiltration rates	Direction/re-direction of downspouts/roof drainage to discharge to pervious surfaces, <u>where possible</u> , to reduce runoff, while meeting all other City of Ottawa lot grading requirements. Amended topsoil, or a depth of topsoil up to 300 mm, provides runoff volume reduction benefits and is <u>encouraged (but not mandatory) as a best practice</u> over all soft landscaped surfaces.	Not applicable	Not applicable	Not applicable
Draining to the Ottawa River					
Development subject to Plan of Subdivision or Site Plan Control approval(s) - <u>discharging directly to the Ottawa River</u>					
2	all soil infiltration rates	A minimum on-site retention of the 10 mm design storm; refer to LID references ⁽ⁱ⁾ for guidance on prudent approach to planning infiltration-based LID best management practices. Assumptions re: non-viability of infiltration measures must be substantiated. A green roof, rain harvesting measures and/or a combination of detention/retention measures ⁽ⁱⁱ⁾ could be implemented to provide further runoff volume reduction.	On-site removal of 80% of TSS; some of which may be achieved by on-site retention of first 10 mm of rainfall.	As per City of Ottawa Sewer Design Guideline	Not applicable
Draining to Pinecrest Creek					
Development subject to Plan of Subdivision or Site Plan Control approval(s) - <u>discharging upstream of the Ottawa River Parkway pipe (ORPP) inlet</u>					
3	all soil infiltration rates	A minimum on-site retention of the 10 mm design storm; refer to LID references ⁽ⁱ⁾ for guidance on prudent approach to planning infiltration-based LID best management practices. Assumptions re: non-viability of infiltration measures must be substantiated. A green roof, rain harvesting measures and/or a combination of detention/retention measures ⁽ⁱⁱ⁾ could be implemented to provide further runoff volume reduction.	On-site removal of 80% of TSS; some of which may be achieved by on-site retention of first 10 mm of rainfall and detention of the 25 mm design storm ⁽ⁱⁱⁱ⁾ .	The more stringent of the following criteria will govern: i) 1:100 year discharge from site not to exceed 33.5 L/s/ha) or; ii) Requirements of City of Ottawa Sewer Design Guideline.	Control (detain) the runoff from the 25 mm design storm ⁽ⁱⁱⁱ⁾ such that the peak outflow from the site does not exceed 5.8 L/s/ha.
Development subject to Plan of Subdivision or Site Plan Control approval(s) - <u>discharging directly to the Ottawa River Parkway pipe</u>					
4	all soil infiltration rates	A minimum on-site retention of the 10 mm design storm; refer to LID references ⁽ⁱ⁾ for guidance on prudent approach to planning infiltration-based LID best management practices. Assumptions re: non-viability of infiltration measures must be substantiated. A green roof, rain harvesting measures and/or a combination of detention/retention measures ⁽ⁱⁱ⁾ could be implemented to provide further runoff volume reduction.	On-site removal of 80% of TSS; some of which may be achieved by on-site retention of first 10 mm of rainfall.	The more stringent of the following criteria will govern: i) 1:100 year discharge from site not to exceed 33.5 L/s/ha) or; ii) Requirements of City of Ottawa Sewer Design	Not applicable

Notes:

- (i) Re: Infiltration measures: Beyond the targets specified in this table, the planning, design and use of these systems shall be in accordance with the guidance in the Stormwater Management Planning and Design Manual (MOE, 2003); the Low Impact Development Stormwater Management Planning and Design Guide (CVC and TRCA, 2010); the Low Impact Development Stormwater Management Planning and Design Wiki at: wiki.sustainabletechnologies.ca; and Draft No.2 Low Impact Development (LID) Stormwater Management Guidance Manual (MOECC, November 2017) or the final version of this Manual, when available. As noted in the MOECC LID SWM Guidance Manual, a prudent approach to planning infiltration-based LID best management practices on any site involves delineating catchment areas that contain high risk site activities and isolating them by applying non-infiltration-based practices to these areas.
- (ii) Retention is to hold or retain stormwater on a more permanent basis such as for infiltration to the surrounding soils. Detention is the temporary storage or detaining of stormwater for eventual release to the downstream system.
- (iii) 25 mm 4-hour Chicago design storm

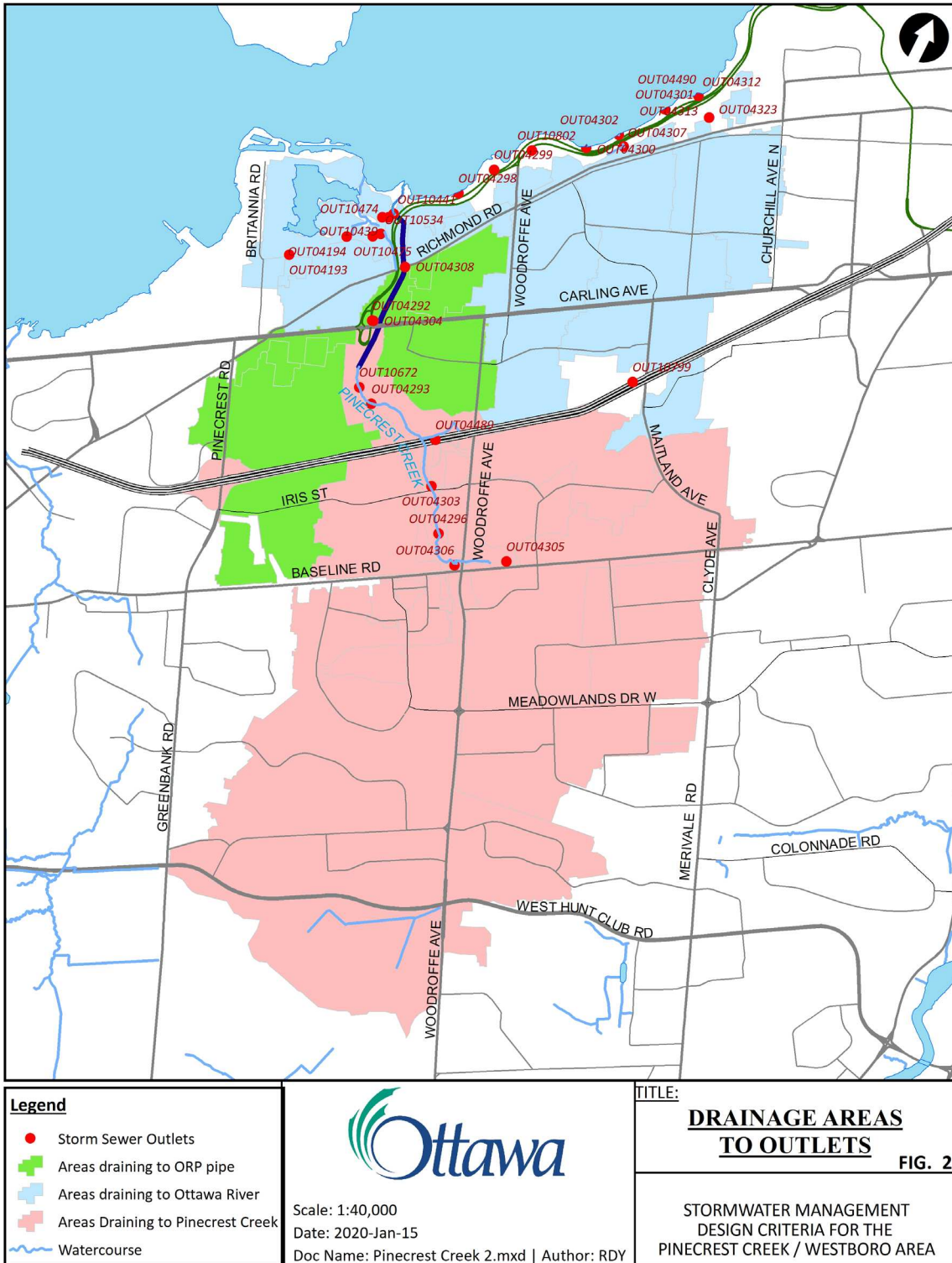

Figure 2: Drainage Areas to Outlets

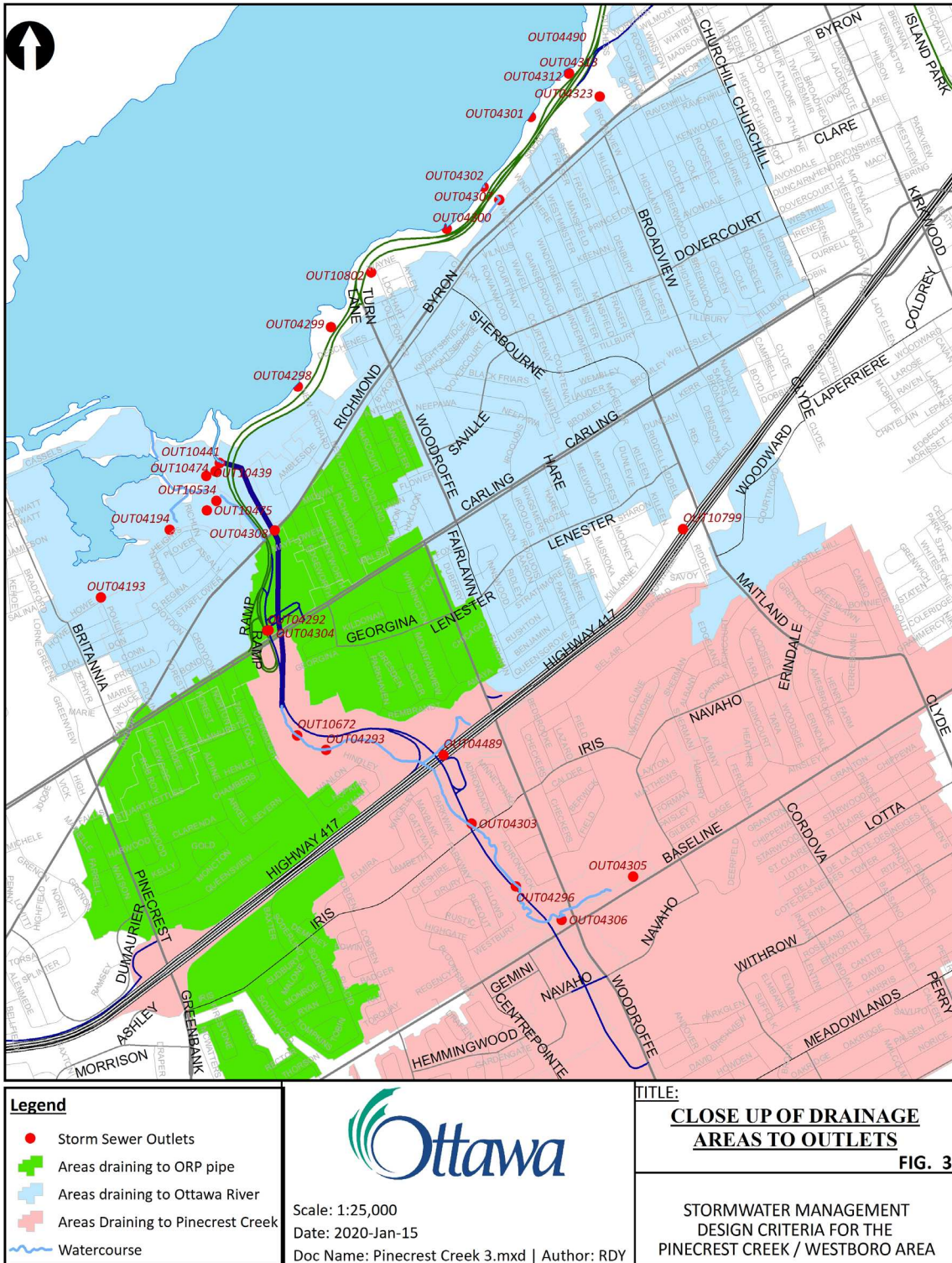

Figure 3: Close-up of Drainage Areas to Outlets

Note that, as outlined in **Table 1**, all development draining to Pinecrest Creek upstream of the ORPP shall control site runoff from the 25 mm 4-hour Chicago storm to a peak unit outflow rate of 5.8 L/s/ha regardless of whether the first 10 mm of runoff volume will be retained on-site. The required on-site storage volume, to control the runoff from the 25 mm storm, will vary from site to site based on the amount of volume retained or infiltrated.

3.4.2 Draining Directly to the Ottawa River (Water Quality)

The following runoff volume control criterion applies to catchments discharging directly to the Ottawa River. Those catchments are shown on **Figures 2 and 3**.

To mitigate the cumulative impacts of infill and redevelopment and not aggravate existing water quality degradation, development shall capture and retain (infiltrate or abstract) the first 10 mm of rainfall. This 10 mm target can be partially achieved by the default initial abstraction (IA) values applicable in urban areas. The Sewer Design Guideline allows a designer to account for a 4.67 mm IA on all soft landscaped surfaces and a 1.57 mm IA on all hardscaped surfaces. Refer to the references cited in the notes of **Table 1** for guidance on prudent approaches to planning infiltration-based LID measures. A green roof or roofs, rain harvesting measures and/or a combination of retention measures could be implemented to provide further runoff volume control.

3.5 Quality Control

Enhanced level of treatment (equivalent to long-term average TSS removal of 80%) is required for water quality control. This requirement may, in some cases, be accomplished by means of conventional measures (e.g., with a combination of end-of-pipe facilities such as oil/grit separators and filters). The water quality benefits of runoff volume control are also recognized in the *Draft No.2 LID SWM Guidance Manual (MOECC, 2017)*, which notes that SWM measures that achieve control of the regionally specific 90th percentile event (27mm for Ottawa) shall be considered to have achieved Enhanced level of treatment for the respective contributing drainage area.

Appendix E Background Reports



Geotechnical
Engineering

Environmental
Engineering

Hydrogeology

Geological
Engineering

Materials Testing

Building Science

Noise and Vibration
Studies

Geotechnical Investigation

Proposed Mixed-Use Development
2475 Regina Street
Ottawa, Ontario

Prepared For

Parkway House Development Fund LP

Paterson Group Inc.

Consulting Engineers
154 Colonnade Road South
Ottawa (Nepean), Ontario
Canada K2E 7J5

Tel: (613) 226-7381
Fax: (613) 226-6344
www.patersongroup.ca

August 18, 2021

Report: PG5901-1

5.0 Discussion

5.1 Geotechnical Assessment

From a geotechnical perspective, the subject site is considered suitable for the proposed development. It is recommended that the proposed high-rise buildings each be founded on a raft foundation placed on an undisturbed, compact to dense glacial till bearing surface. It is further recommended that the low-rise buildings, as well as portions of the underground parking levels which extend beyond the footprints of the high-rise buildings, be supported on conventional spread footings bearing on undisturbed, compact to dense glacial till.

Where loose and/or soft glacial till is encountered at the underside of footing or raft, it should be sub-excavated to the undisturbed, compact to dense glacial till and re-instated with engineered fill.

Further, it is anticipated that cobbles and boulders will be encountered frequently throughout servicing trenches and building excavations. All contractors should be prepared for the removal of boulders and potentially oversized boulders throughout the subject site.

The above and other considerations are discussed in the following sections.

5.2 Site Grading and Preparation

Stripping Depth

Topsoil and deleterious fill, such as those containing organic materials, should be stripped from under any buildings, paved areas, pipe bedding and other settlement sensitive structures.

Existing foundation walls and other construction debris should be entirely removed from within the building perimeters. Under paved areas, existing construction remnants such as foundation walls should be excavated to a minimum of 1 m below final grade.

Protection of Subgrade (Raft Foundation)

Where a raft foundation is used, the raft subgrade would consist of a glacial till deposit, and it is recommended that a minimum 75 mm thick lean concrete mud slab be placed on the undisturbed glacial till subgrade shortly after the completion of the excavation. The main purpose of the mud slab is to reduce the risk of disturbance of the subgrade under the traffic of workers and equipment.

The geotechnical capacity of each rock anchor should be proof tested at the time of construction. More information on testing can be provided upon request. Compressive strength testing is recommended to be completed for the rock anchor grout. A set of grout cubes should be tested for each day that grout is prepared.

5.8 Pavement Design

For design purposes, it is recommended that the rigid pavement structure for the lowest level of the underground parking structure should consist of Category C2, 32 MPa concrete at 28 days with air entrainment of 5 to 8%. The recommended rigid pavement structure is further presented in Table 4 below. The flexible pavement structure presented in Tables 5 and 6 should be used for exterior, at grade parking areas and access lanes, respectively.

Table 4 - Recommended Rigid Pavement Structure - Lower Parking Level	
Thickness (mm)	Material Description
125	Exposure Class C2 – 32 MPa Concrete (5 to 8 % Air Entrainment)
300	BASE - OPSS Granular A Crushed Stone
SUBGRADE – Imported fill or OPSS Granular B Type I or II or material placed over in situ soil.	

To control cracking due to shrinking of the concrete floor slab, it is recommended that strategically located saw cuts be used to create control joints within the concrete floor slab of the lower underground parking level. The control joints are generally recommended to be located at the center of the column lines and spaced at approximately 24 to 36 times the slab thickness (for example, a 0.15 m thick slab should have control joints spaced between 3.6 and 5.4 m). The joints should be cut between 25 and 30% of the thickness of the concrete floor slab and completed as early as 4 hours after the concrete has been poured during warm temperatures and up to 12 hours during cooler temperatures.

Table 5 - Recommended Pavement Structure – Car Only Parking Areas	
Thickness (mm)	Material Description
50	Wear Course - HL-3 or Superpave 12.5 Asphaltic Concrete
150	BASE - OPSS Granular A Crushed Stone
300	SUBBASE - OPSS Granular B Type II
SUBGRADE - OPSS Granular B Type I or II placed over in-situ soil, or concrete fill.	

Table 6 - Recommended Asphalt Pavement Structure - Access Lanes and Heavy Loading Parking Areas	
Thickness (mm)	Material Description
40	Wear Course – HL-3 or Superpave 12.5 Asphaltic Concrete
50	Wear Course – HL-8 or Superpave 19.0 Asphaltic Concrete
150	BASE - OPSS Granular A Crushed Stone
300	SUBBASE - OPSS Granular B Type II
SUBGRADE - OPSS Granular B Type I or II placed over in-situ soil, or concrete fill.	

Minimum Performance Graded (PG) 58-34 asphalt cement should be used for this project. The pavement granular base and subbase should be placed in maximum 300 mm thick lifts and compacted to a minimum of 99% of the material's SPMDD using suitable vibratory equipment, noting that excessive compaction can result in subgrade softening.

If soft spots develop in the subgrade during compaction or due to construction traffic, the affected areas should be excavated and replaced with OPSS Granular B Type I or II material.

7.0 Recommendations

It is recommended that the following be completed once the master plan and site development are determined.

- Review of the geotechnical aspects of the excavation contractor's shoring design, if required, prior to construction.
- Review of waterproofing details for the elevator shaft and building sump pits.
- Review and inspection of the foundation waterproofing system and all foundation drainage systems.
- Observation of all bearing surfaces prior to the placement of concrete.
- Sampling and testing of the concrete and fill materials.
- Periodic observation of the condition of unsupported excavation side slopes in excess of 3 m in height, if applicable.
- Complete a full inspection program of the installation of the perimeter and underground floor drainage system during construction.
- Observation of all subgrades prior to backfilling.
- Field density tests to determine the level of compaction achieved.
- Sampling and testing of the bituminous concrete including mix design reviews.

A report confirming that these works have been conducted in general accordance with our recommendations could be issued upon the completion of a satisfactory inspection program by the geotechnical consultant.

8.0 Statement of Limitations

The recommendations provided herein are in accordance with our present understanding of the project. Paterson requests permission to review the recommendations when the drawings and specifications are completed.

A soils investigation is a limited sampling of a site. Should any conditions at the site be encountered which differ from those at the test locations, Paterson requests immediate notification to permit reassessment of our recommendations.

The recommendations provided herein should only be used by the design professionals associated with this project. They are not intended for contractors bidding on or undertaking the work. The latter should evaluate the factual information provided in this report and determine the suitability and completeness for their intended construction schedule and methods. Additional testing may be required for their purposes.

The present report applies only to the project described in this document. Use of this report for purposes other than those described herein or by person(s) other than Parkway House Development Fund LP or their agents is not authorized without review by Paterson for the applicability of our recommendations to the alternative use of the report.

Paterson Group Inc.



Kevin A. Pickard, EIT.



Scott S. Dennis, P.Eng.

Report Distribution:

- Parkway House Development Fund LP (email copy)
- Paterson Group (1 copy)



With every community, we redefine what's possible.

Stantec is a global leader in sustainable engineering, architecture, and environmental consulting. The diverse perspectives of our partners and interested parties drive us to think beyond what's previously been done on critical issues like climate change, digital transformation, and future-proofing our cities and infrastructure. We innovate at the intersection of community, creativity, and client relationships to advance communities everywhere, so that together we can redefine what's possible.