

BLOCK 242  
(COMMERCIAL)

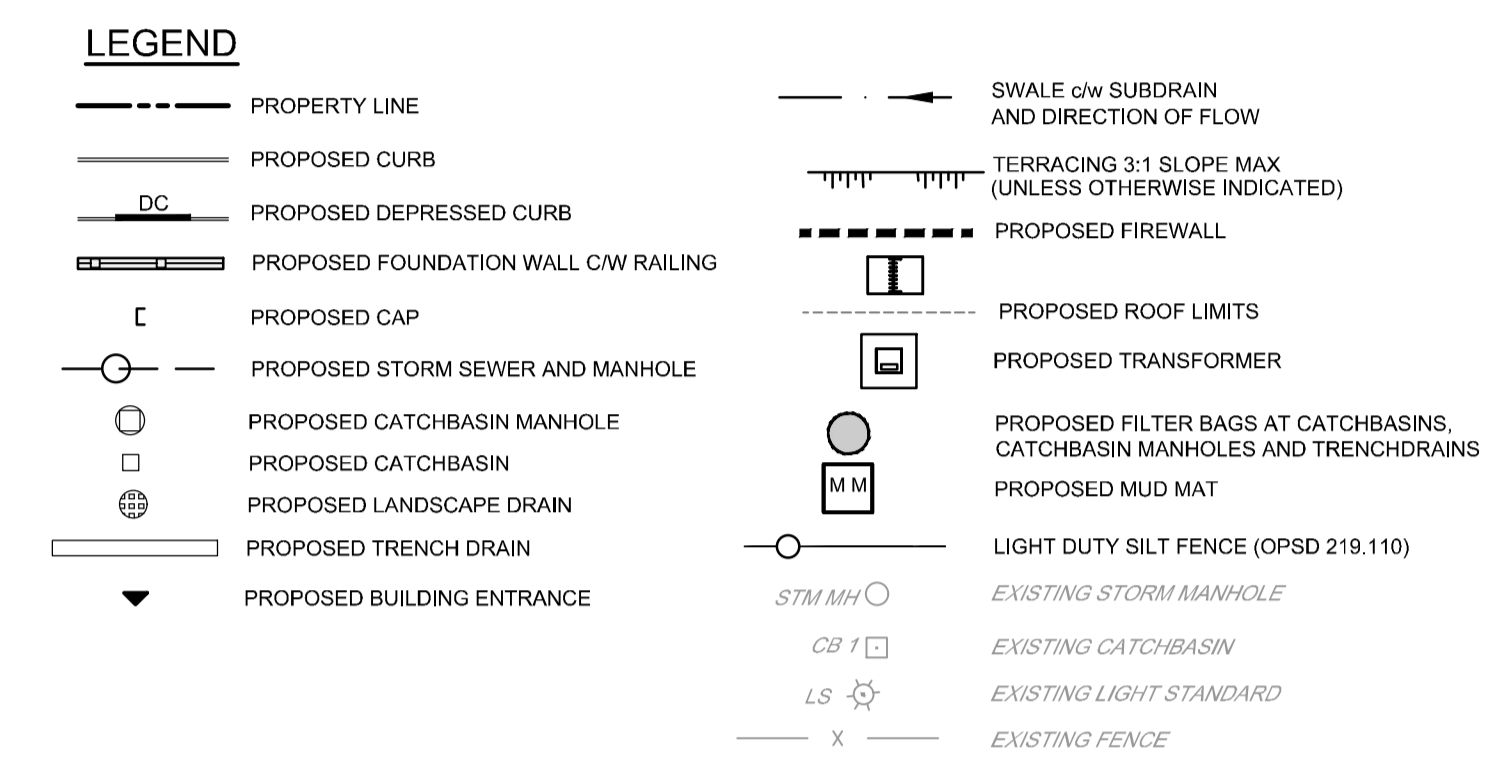

- EROSION AND SEDIMENT CONTROL NOTES:**
- THE CONTRACTOR SHALL IMPLEMENT BEST MANAGEMENT PRACTICES, TO PROVIDE FOR PROTECTION OF THE AREA DRAINAGE SYSTEM AND THE RECEIVING WATERCOURSE. DURING CONSTRUCTION ACTIVITIES THE CONTRACTOR ACKNOWLEDGES THAT FAILURE TO IMPLEMENT APPROPRIATE EROSION AND SEDIMENT CONTROL MEASURES MAY BE SUBJECT TO PENALTIES IMPOSED BY ANY APPLICABLE REGULATORY AGENCY.
- 1) THE OWNER AGREES TO PREPARE AND IMPLEMENT AN EROSION AND SEDIMENT CONTROL PLAN TO THE SATISFACTION OF THE CITY OF OTTAWA, APPROPRIATE TO THE SITE CONDITIONS, PRIOR TO UNDERTAKING ANY SITE ALTERATIONS (FILLING, GRADING, REMOVAL OF VEGETATION, ETC.) AND DURING ALL PHASES OF SITE PREPARATION AND CONSTRUCTION IN ACCORDANCE WITH THE CURRENT BEST MANAGEMENT PRACTICES FOR EROSION AND SEDIMENT CONTROL SUCH AS BUT NOT LIMITED TO INSTALLING FILTER CLOTHS ACROSS MANHOLE/CATCHBASIN LIDS TO PREVENT SEDIMENTS FROM ENTERING STRUCTURES AND INSTALL AND MAINTAIN A LIGHT DUTY SILT FENCE BARRIER AS REQUIRED.
  - 2) THE CONTRACTOR SHALL PLACE FILTER BAGS UNDER THE CATCHBASIN AND MANHOLE GRATES FOR THE DURATION OF CONSTRUCTION AND WILL REMAIN IN PLACE DURING ALL PHASES OF CONSTRUCTION.
  - 3) SILT FENCING FOR ENTIRE PERIMETER OF SITE, SHALL BE UTILIZED TO CONTROL EROSION FROM THE SITE DURING CONSTRUCTION.
  - 4) THE CONTRACTOR ACKNOWLEDGES THAT FAILURE TO IMPLEMENT EROSION AND SEDIMENT CONTROL MEASURES MAY BE SUBJECT TO PENALTIES IMPOSED BY ANY APPLICABLE REGULATORY AGENCY.
  - 5) PROVIDE MUD MATS AT ALL CONSTRUCTION ACCESS POINTS TO MINIMIZE SEDIMENT TRANSPORT OFFSITE.
  - 6) EROSION AND SEDIMENT CONTROL MEASURES MAY BE MODIFIED IN THE FIELD AT THE DISCRETION OF THE CITY OF OTTAWA SITE INSPECTOR OR CONSERVATION AUTHORITY.

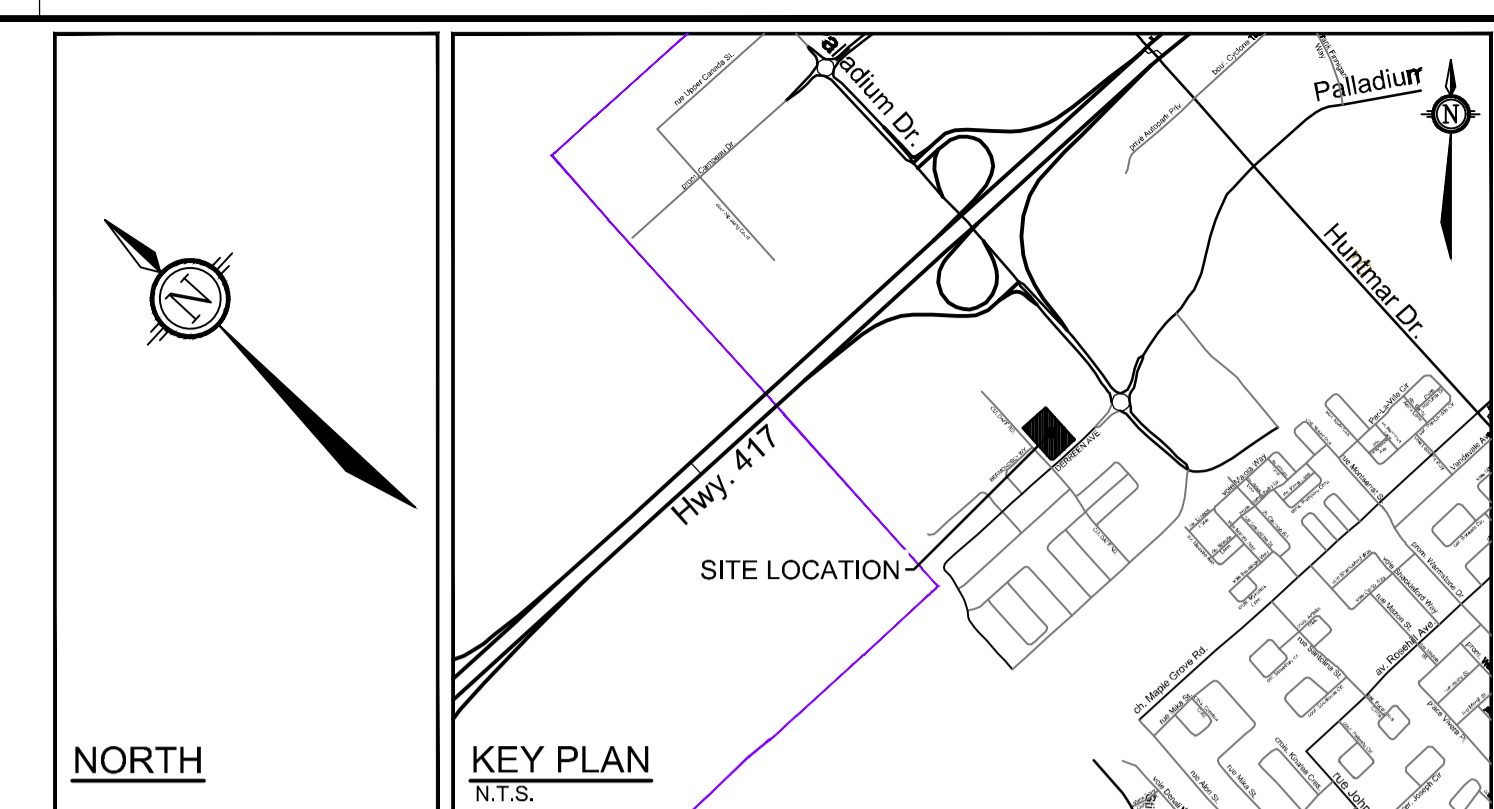
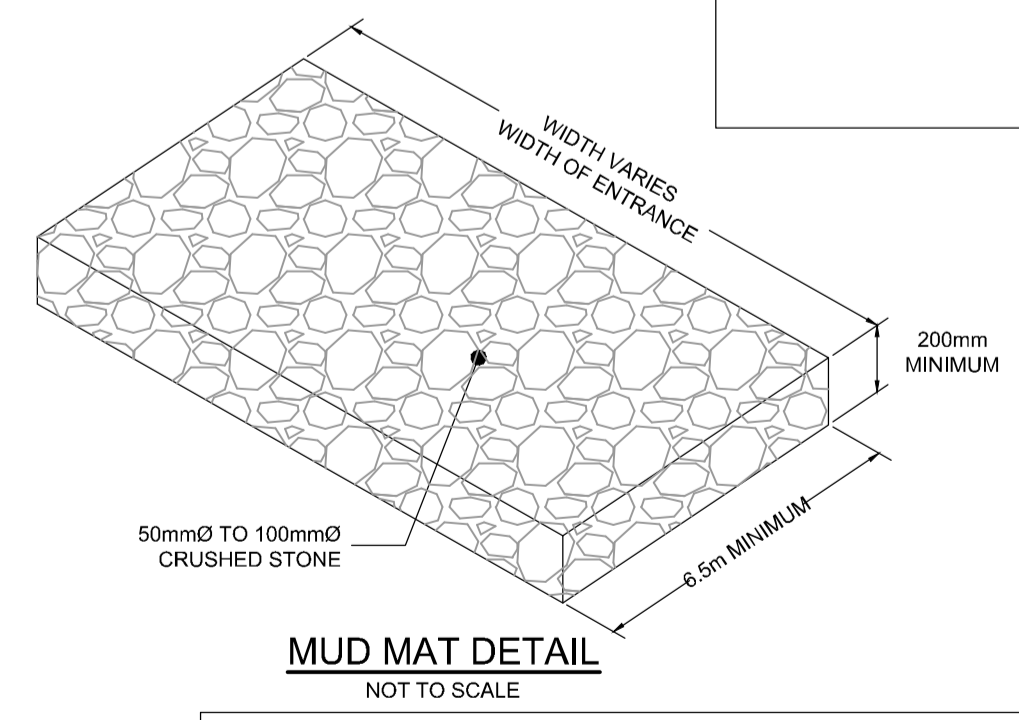
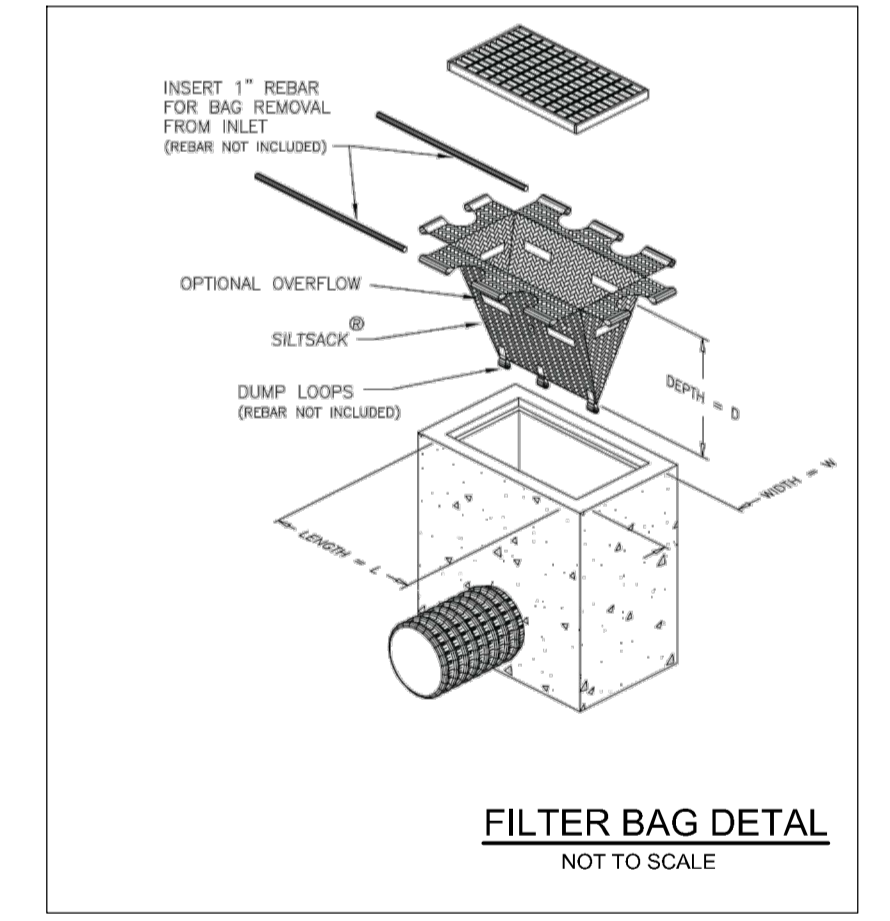

REFER TO 123194-ND FOR ADDITIONAL NOTES & DETAILS

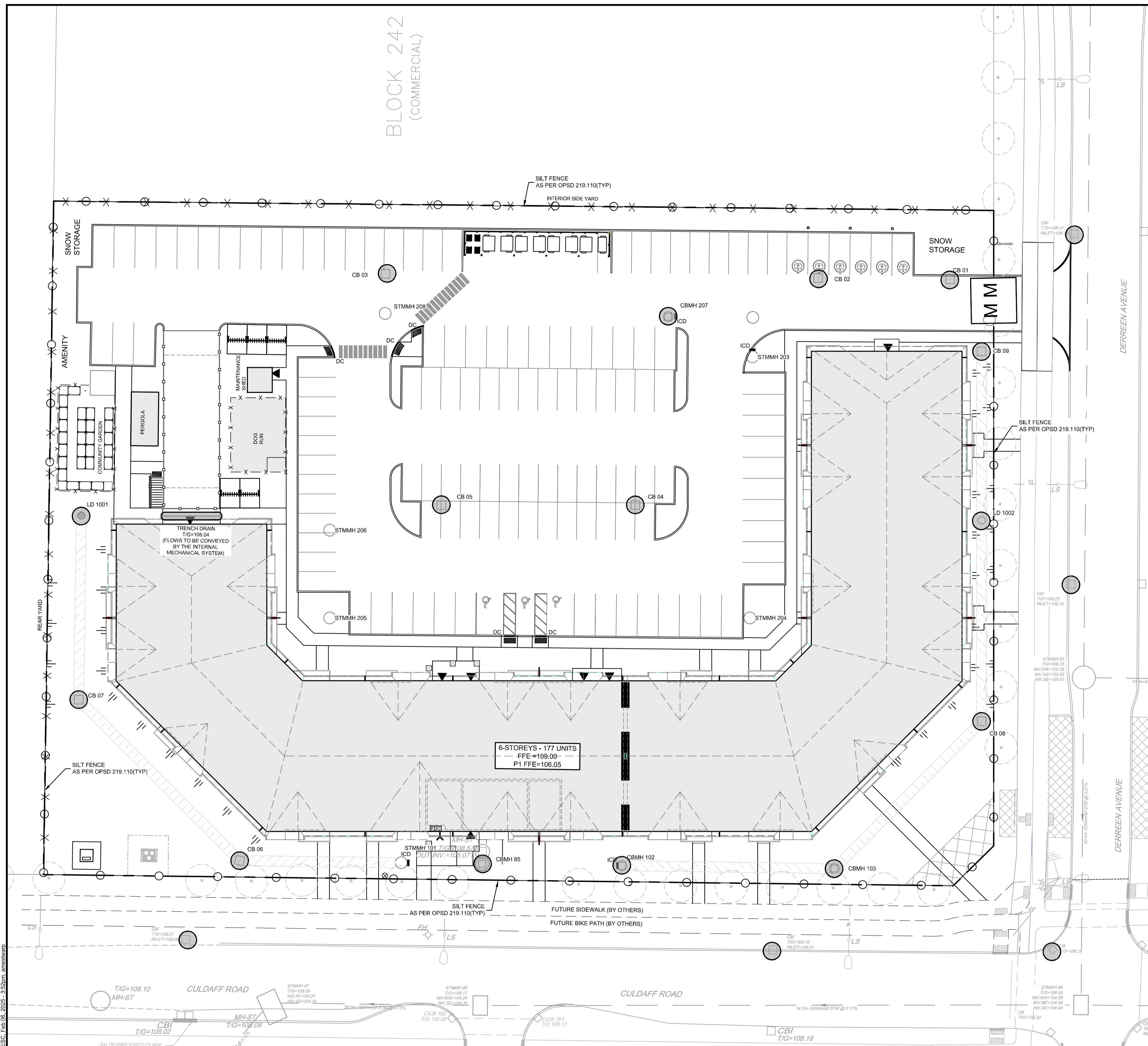

**NOTE:**  
THE POSITION OF ALL POLE LINES, CONDUITS, WATERMANS, SEWERS AND OTHER UNDERGROUND AND OVERGROUND UTILITIES AND STRUCTURES IS NOT NECESSARILY SHOWN ON THE CONTRACT DRAWINGS, AND WHERE SHOWN, THE ACCURACY OF THE POSITION OF SUCH UTILITIES AND STRUCTURES IS NOT GUARANTEED. BEFORE STARTING WORK, DETERMINE THE EXACT LOCATION OF ALL SUCH UTILITIES AND STRUCTURES AND ASSUME ALL LIABILITY FOR DAMAGE TO THEM.

**NOT FOR CONSTRUCTION**

No.	REVISION	DATE	BY
2.	REVISED PER CITY COMMENTS	FEB 28/2025	ARM
1.	ISSUED FOR SITEPLAN APPLICATION	OCT/17/24	ARM

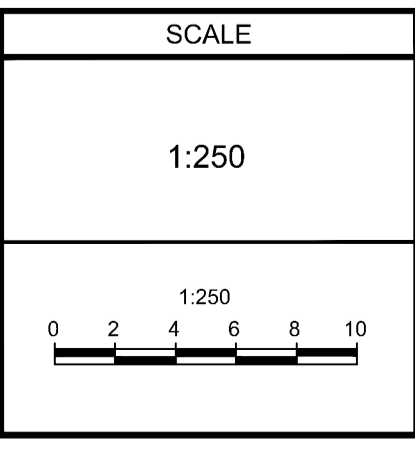

DESIGN

ARM

CHECKED

GJM

DRAWN

MF/ARM

CHECKED

ARM

APPROVED

GJM

**FOR REVIEW ONLY**

**NOVATECH**

Engineers, Planners & Landscape Architects  
Suite 200, 240 Michael Cowpland Drive  
Ottawa, Ontario, Canada K2M 1P6

Telephone (613) 254-9643  
Facsimile (613) 254-5867  
Website www.novatech-eng.com

LOCATION CITY OF OTTAWA 425 CULDAFF ROAD		PROJECT No.	123194
DRAWING NAME EROSION AND SEDIMENT CONTROL PLAN		REV	REV#2
		DRAWING No.	123194-ESC