

WASTE CALCULATIONS		
	REQUIRED	PROPOSED
GARBAGE	19.3 y ³	20 y ³
GMP	3 y ³	4 y ³
FIBRE	6.7 y ³	8 y ³
ORGANICS	870 L	960 L

LEGEND	
	GARBAGE CANS (NUMBER REPRESENTS Y ³)
	FIBRE CANS (NUMBER REPRESENTS Y ³)
	GMP CANS (NUMBER REPRESENTS Y ³)
	240 L ORGANIC CANS

APPROVED
By Kersten Nitsche at 3:25 pm, Oct 02, 2025

Kersten Nitsche
KERSTEN NITSCHÉ, MCIP RPP
MANAGER (A), DEVELOPMENT REVIEW WEST
PLANNING, DEVELOPMENT AND BUILDING SERVICES
DEPARTMENT, CITY OF OTTAWA



B BROADSTREET
PROPERTIES LTD.
100 St Anns, Campbell River, B.C.
(T)250.286.8045 (F)250.286.8046
www.broadstreet.ca



PROJECT STATUS:
DEVELOPMENT PERMIT

Revision Schedule		
No.	Description	Revision Date
A	ISSUED FOR D.P.	OCT 15, 2024
B	RE-ISSUED FOR D.P.	FEB 14, 2025
C	RE-ISSUED FOR DP.P. - 1	JUN 02, 2025
D	RE-ISSUED FOR DP.P. - 2	AUG 14, 2025

SEAL: **ABELEARCHITECTURE**
THOMAS G. ABELE ARCHITECTS
ONTARIO PROFESSIONAL ARCHITECTS
THOMAS G. ABELE
LICENCE
9953
2025-08-19

TRADE CONTRACTORS SHALL VERIFY ALL DIMENSIONS AND REPORT ANY DISCREPANCIES OR INCONSISTENCIES TO SEYMOUR PACIFIC DEVELOPMENTS LTD., WITHOUT DELAY. FOR CLARIFICATION AND/OR CONFIRMATION. DO NOT SCALE DRAWINGS. DESIGNS REPRESENTED AND DRAWINGS USED AS INSTRUMENTS OF SERVICE SHALL REMAIN THE COPYRIGHT AND PROPERTY OF SEYMOUR PACIFIC DEVELOPMENTS LTD. ANY REPRODUCTION OR USE FOR ANY PURPOSE OTHER THAN THAT AUTHORIZED BY SEYMOUR PACIFIC DEVELOPMENTS LTD. IS PROHIBITED.

CONTRACTORS SHALL REMAIN FAMILIAR WITH, SHALL REFER TO, AND SHALL PERFORM IN ACCORDANCE WITH LOCAL LAWS, REGULATIONS AND BUILDING CODES. CONTRACTORS SHALL MAINTAIN GOOD INDUSTRY BUILDING AND SAFETY PRACTICES CONSISTENT WITH THE CONTRACT INTENT AND THE REQUIREMENTS OF JURISDICTIONAL AUTHORITIES.

ADDITIONAL CLAIMS AND COSTS RELATED TO NON-MATERIAL CHANGES WILL NOT BE ACCEPTED BY SEYMOUR PACIFIC DEVELOPMENTS LTD. NON-MATERIAL CHANGES ARE DEEMED TO BE PLAN CHANGES OR SPECIFICATION ADJUSTMENTS THAT DO NOT SUBSTANTIALLY AFFECT THE VALUE, TIME, COST AND QUALITY OF CONSTRUCTION.

CONTRACTORS SHALL MAKE EVERY REASONABLE EFFORT TO MAINTAIN SCHEDULE TARGETS AND PROVIDE GOOD EFFICIENCY, PROGRESS, WORKMANSHIP AND QUALITY TOWARD DEFICIENCY-FREE RESULTS.

PROJECT NAME:
PALLADIUM TERRACE

PROJECT NUMBER:
VP 2402

ADDRESS:
425 CULDAFF RD
OTTAWA, ON

DRAWING TITLE:
WASTE + RECYCLING PLAN

DRAWN BY: NG
CHECKED BY: TH
DATE: AUG 14, 2025
SCALE: As indicated

DRAWING #: **A1.04**
REV #: **D**

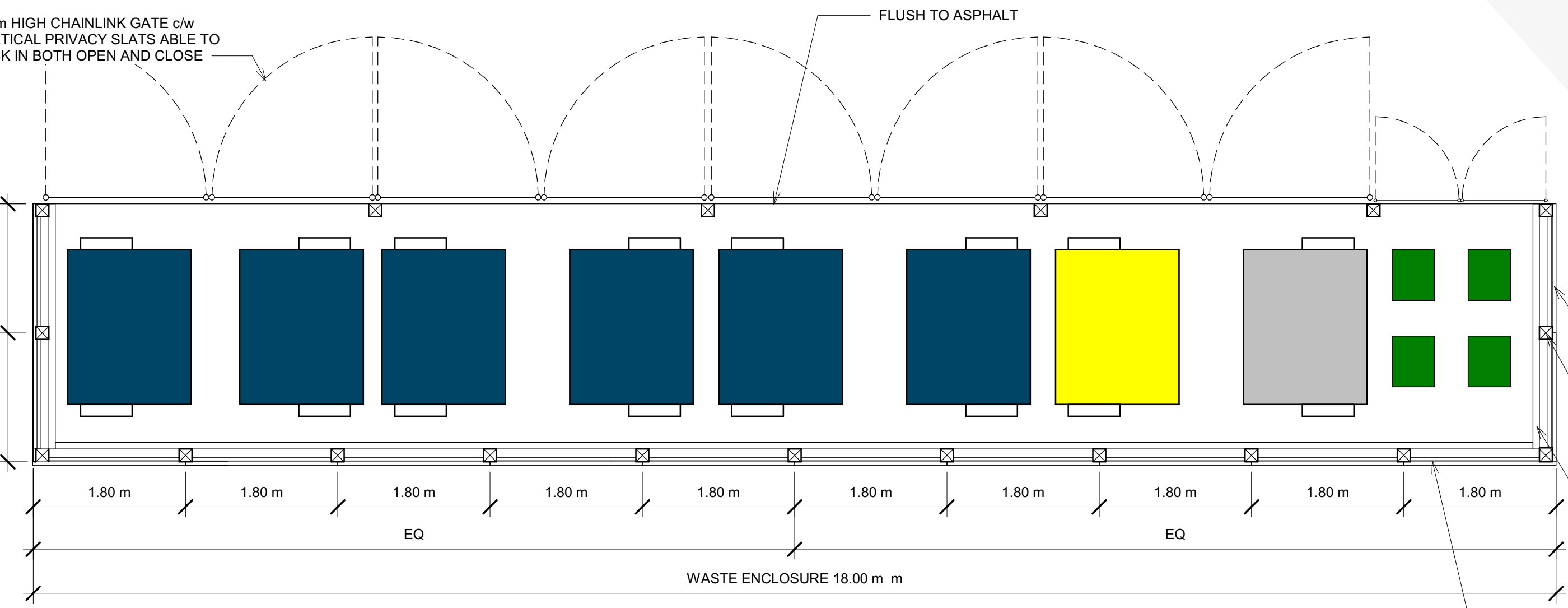
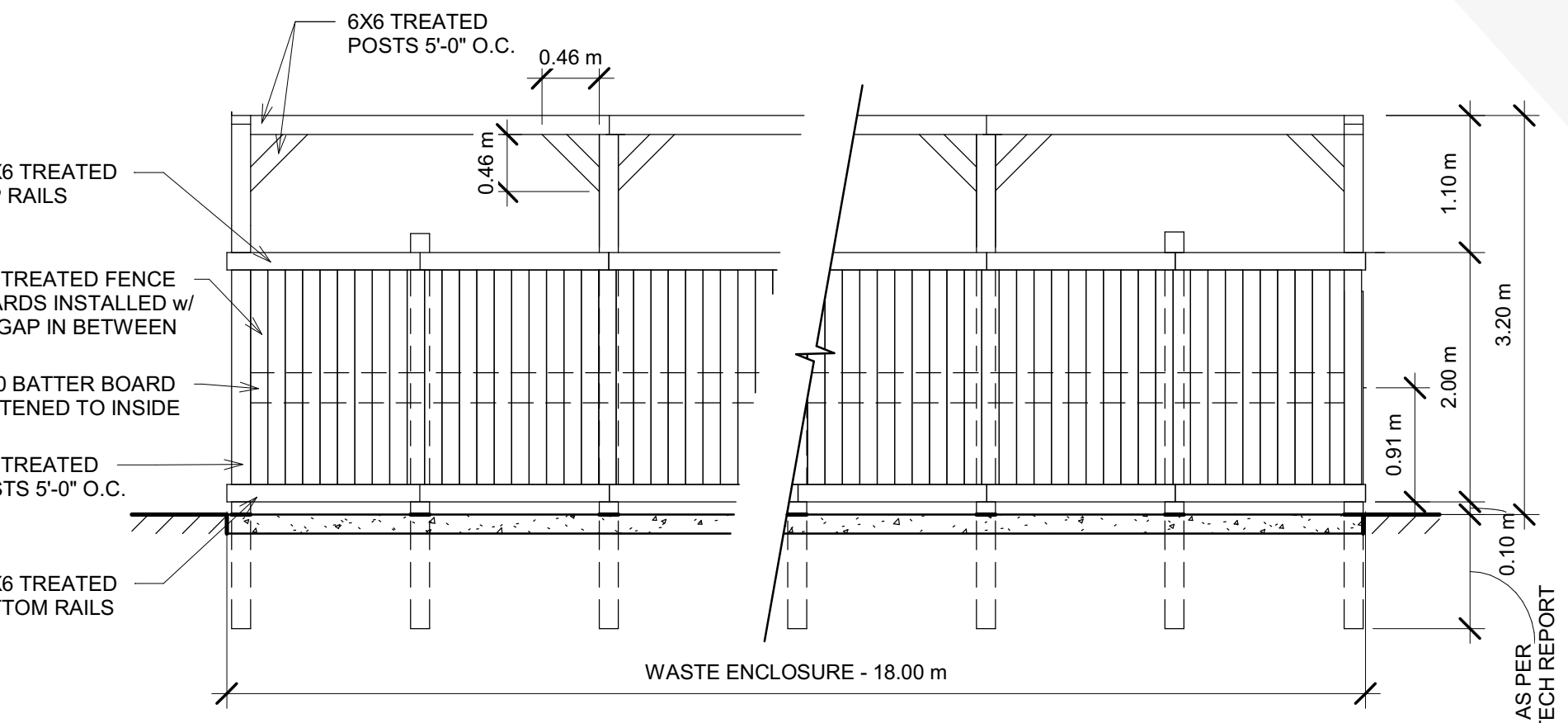
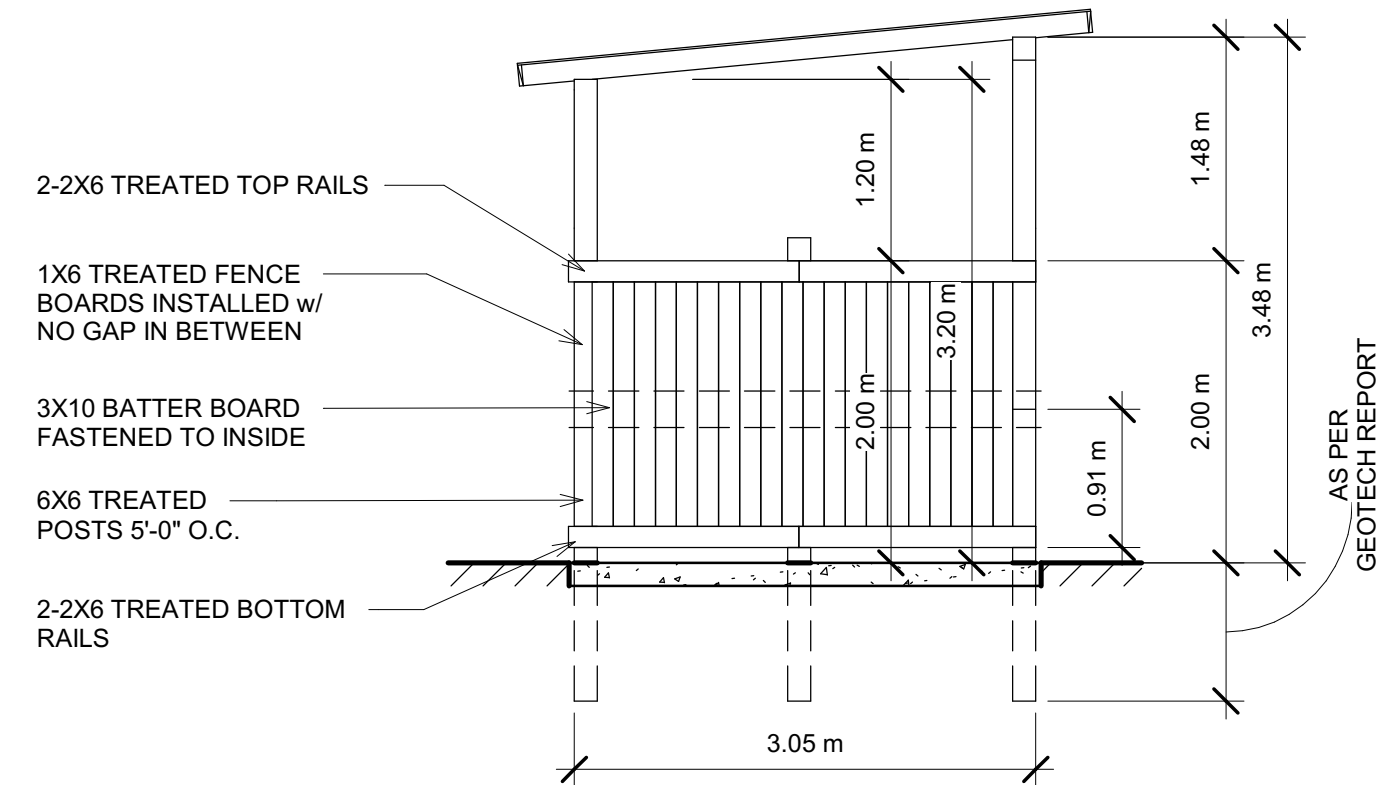
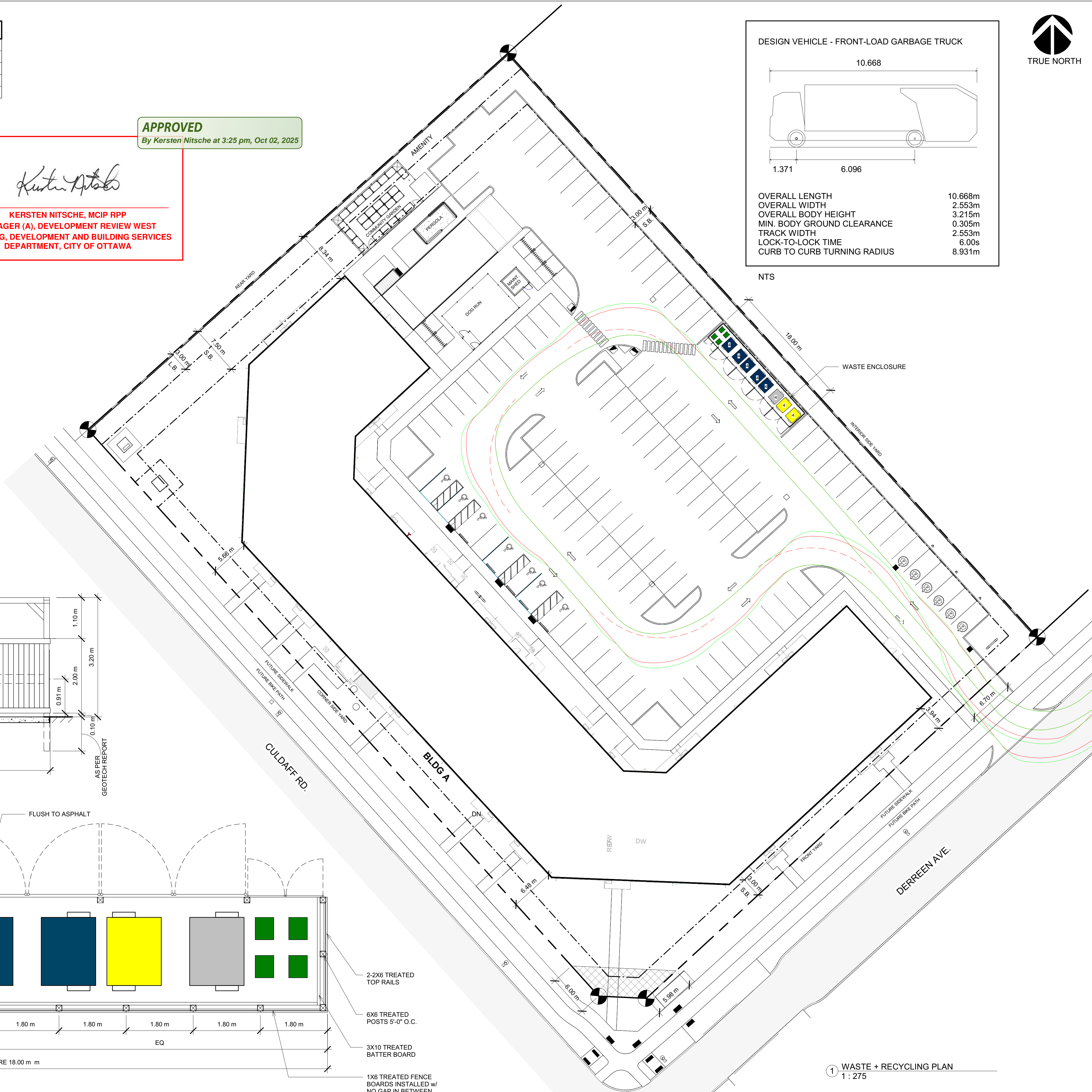
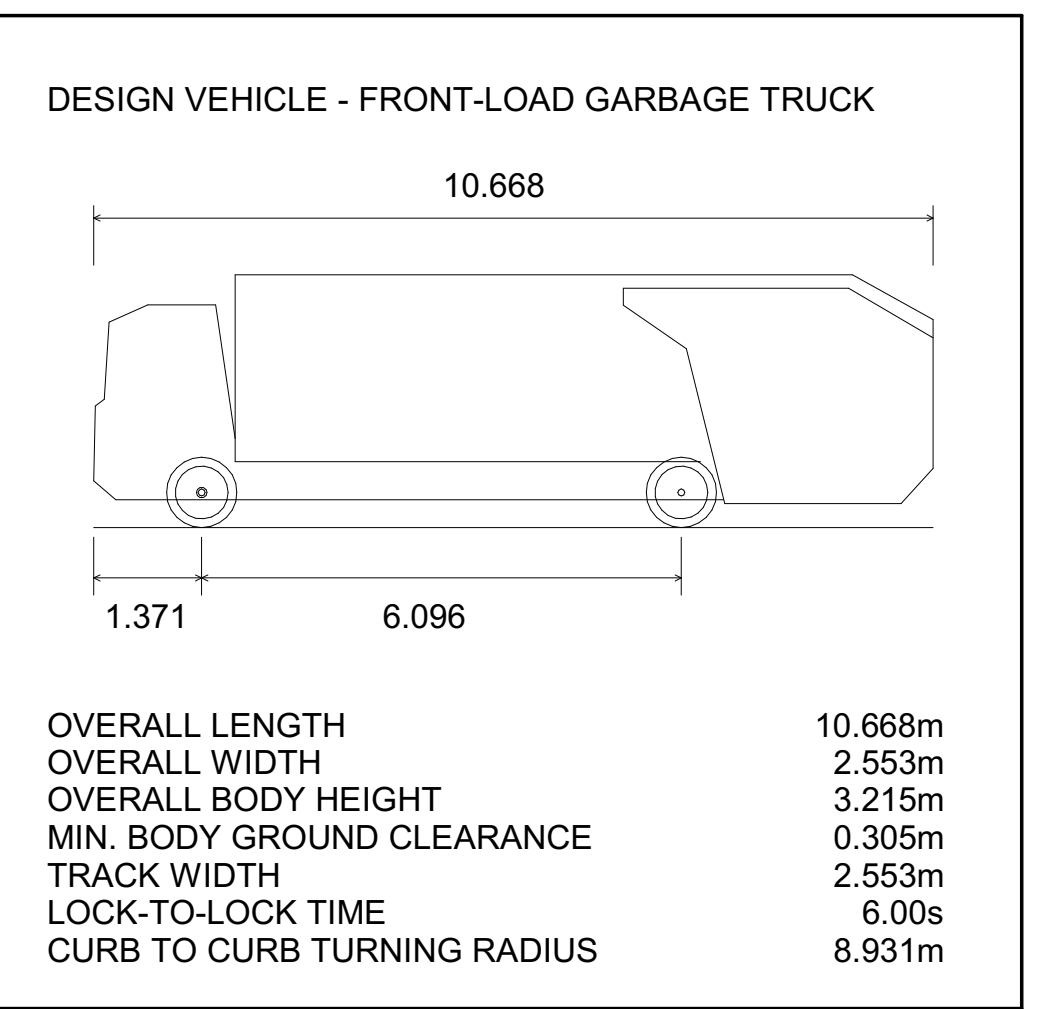

1 WASTE + RECYCLING PLAN
1:275

08/14/2025 11:27:03 AM

PLAN #: 19281 FILE #: D07-12-24-0140