



Kollaard Associates

Engineers

210 Prescott Street, Unit 1
P.O. Box 189
Kemptville, Ontario K0G 1J0

Civil • Geotechnical •
Structural • Environmental •
Hydrogeology •

(613) 860-0923
FAX: (613) 258-0475

STORMWATER
MANAGEMENT REPORT

CAMM HEAVY MACHINERY MOVERS
WAREHOUSING FACILITY
6622 BANK STREET
OTTAWA, ON

Prepared For:

CAMM Warehousing and Rentals Inc.
6622 Bank St.
Ottawa, ON K0A 2P0

PROJECT#: 230156

DISTRIBUTION

6 copies – City of Ottawa
1 copies – CAMM Warehousing and Rentals Inc.
1 copy – Kollaard Associates Inc.

Rev 0 – Issued for Site Plan Approval
Rev 1 – Issued in Response to Incomplete Submission
Rev 2 – Revised Drawings for City Comments

July 31, 2024
October 02, 2024
January 10, 2024



Professional Engineers
Ontario

Authorized by the Association of Professional Engineers
Of Ontario to offer professional engineering services



TABLE OF CONTENTS

LIST OF APPENDICES	2
LIST OF DRAWINGS	3
LIST OF TABLES.....	3
1 INTRODUCTION.....	4
1.1 Purpose	4
1.2 Lot Description.....	4
1.3 Previous Development.....	4
1.4 Proposed Development.....	5
2 STORMWATER DESIGN	5
2.1 Stormwater Management Design Criteria	5
2.1.1 Quantity Control	5
2.1.2 Quality Control	6
2.1.3 Additional Criteria.....	6
2.1.4 Approval Authorities	6
2.2 Site Description and Storm Analysis Variables.....	6
2.2.1 Pre-Development Details	6
2.2.2 Post-Development Details.....	8
2.2.3 Storm Analysis Variable Summary	9
2.3 SWM Quantity Control	9
2.3.1 Peak Flow Calculation Method.....	9
2.3.2 Post Development Restricted Flow and Storage	10
2.4 Stormwater Quality Control	14
2.4.1 Quality Control - Filtration.....	14
2.4.2 Discharge through Sand Filter and Infiltration.....	15
2.4.3 Best Management Practices	16
2.5 Low Impact Development (LID) Considerations	17
2.6 Thermal Considerations.....	18
2.7 Groundwater Recharge.....	18
2.7.1 Infiltration Target	18
2.7.2 Site Infiltration	19
2.8 Operation and Maintenance.....	19
2.8.1 Outlet Structures and Culverts	19
3 EROSION AND SEDIMENT CONTROL.....	20
4 CONCLUSIONS.....	21

LIST OF APPENDICES

- Appendix A : Stormwater Management Model
- Appendix B : Product Information
- Appendix C : Drawings



LIST OF DRAWINGS

- 230156– SP – Site Plan
- 230156– PRE – Pre-Development Plan
- 230156– POST – Stormwater Management Plan
- 230156– SER – Site Servicing Plan
- 230156– GR – Site Grading and Drainage Plan
- 230156– DET – Details
- 230156– ESC – Erosion and Sediment Control Plan

LIST OF TABLES

Table 2-1: Summary of Post-Development Site Conditions	9
Table 2-2: Storm Analysis Variable Summary	9
Table 2-3: Allowable Release Rates	10
Table 2-4: Elevation, Storage and Discharge Relationships.....	13
Table 2-5: Maximum Discharge Rate, Storage Requirement and Ponding Depth	13



1 INTRODUCTION

Kollaard Associates was retained by CAMM Warehousing and Rentals Inc. to complete a Stormwater Management Report for a proposed expansion of an industrial development located at 6622 Bank Street, Ottawa, Ontario.

1.1 Purpose

This report will address the stormwater management requirements for the proposed Industrial Development, specifically relating to the requirements of the Shields Creek Subwatershed Study June 2004. This report will summarize the stormwater management (SWM) design requirements and proposed works that will address stormwater flows arising from the site under post-development conditions and will identify any stormwater servicing concerns and also describe any measures to be taken during construction to minimize erosion and sedimentation.

This report will reference the document, “Servicing Design and Stormwater Management Brief” (March, 2018) prepared previously by Kollaard Associates, which covers the previous development on this site.

1.2 Lot Description

For the purposes of this report, Bank Street is considered to be oriented along a north-south axis. The proposed development site is located along the west side of Bank Street. The site is approximately rectangular in shape and extends about 250 metres from Bank Street. The site has a total area of 6.019 hectares and was formerly cleared for agricultural purposes. Based on a review of aerial photography, the land had been fallow for several years prior to the previous development. Stormwater runoff from the site historically consisted of sheet flow to the west or to the roadside ditch along Bank Street.

1.3 Previous Development

This site is the location of a previous development constructed in 2019. The existing development consists of a warehouse building (Building #1) with a footprint of 2310 square metres and an attached office with a footprint of 191 square metres. This development also included on-site storm water management works. Presently, storm water runoff is directed by means of sheet flow to shallow swales along the north, east and south sides of the site. These swales provide quality and quantity control and discharge to the road side ditch along Bank Street. A full description of these works is available in the previous SWM report.



1.4 Proposed Development

The proposed further development of the site will contain a warehouse building (Building #2) with a total footprint of 2,174 square metres which includes accessory office space at the front (east) of the building. This building will face Bank Street in the southeast corner of the property.

An additional warehouse building (Building #3) with a total footprint of 2,174 square metres will be located on the south side of the property. This building will be located west of Building #2 and east of the hydro easement which crosses diagonally the southwest corner of the site.

As with the current Site Plan, storm water runoff within the proposed development area will be directed by means of sheet flow to swales on the east and south sides of the site.

The existing east and south swales are to be modified as per the site grading and servicing plans (230156-GR and 230156-SER) to accommodate the proposed development and satisfy the stormwater quantity and quality criteria.

2 STORMWATER DESIGN

As this development is located on the site of a previous development, considerations have been made to the scope of this report. Given that all of the proposed works related to this development reside in the area that was labelled Catchment 2 in the previous report, only Catchment 2 will be considered in the stormwater calculations in this report. The existing drainage patterns outside of Catchment 2 will remain unchanged. It is considered that the existing storm facilities outside of Catchment 2 will not be altered by this development and have previously been approved by the relevant authorities.

For ease of comparison with the 2018 report, the relevant area will still be termed Catchment 2 in this report.

2.1 Stormwater Management Design Criteria

Design of the proposed stormwater management works was completed in conformance with the design criteria provided by the City of Ottawa during a pre-consultation meeting held on May 23, 2023. The stormwater management design criteria are as follows:

2.1.1 Quantity Control

- Post-development peak runoff rates will be restricted for a 100 year storm event to less than or equal to the pre-development peak runoff rate of a 2 year storm event as per the City of Ottawa
- Post-development peak runoff rates will be restricted for the 2 year storm event to less than or equal half of the pre-development peak runoff rate of a 2 year storm event as per the Shields Creek Subwatershed Study



- Pre-development conditions for the site are to be considered to be the conditions prior to the existing development with a runoff coefficient of $C=0.25$

2.1.2 Quality Control

- Provide an enhanced level of protection with 80 percent removal of total suspended solids for the downstream water body receiving runoff from the site in accordance with South Nation Conservation requirements

2.1.3 Additional Criteria

- Achieve a minimum level of groundwater recharge as required by the Shield's Creek Subwatershed study
- Implement Erosion Control Measures as required to mitigate the potential for offsite transport of sediment during construction

2.1.4 Approval Authorities

The approval authorities for the proposed stormwater management facility consist of the South Nation Conservation Authority (SNCA) and the City of Ottawa.

2.2 Site Description and Storm Analysis Variables

2.2.1 Pre-Development Details

2.2.1.1 Pre-Development Site Conditions

As previously stated, the site is located along the west side of bank street within the Shields Creek Subwatershed. The site has a total area of about 6.019 hectares. Historically the site was fallow agricultural land. For the purposes of the stormwater management design predevelopment conditions were assumed to consist of fallow, grass and brush covered land.

Previous stormwater runoff in general consisted of uncontrolled sheet flow to both the roadside ditch along the east side of the site and uncontrolled flow towards an undesignated wetland area west of the site. Grey's Creek, located south and west of the site provides outlet for the undesignated wetland area, and discharges to the Osgoode Westland Complex approximately 850 metres south of the site.

The proposed development comprises of a 3.578 ha area of the site termed Catchment 2. Currently this portion of the site is a gravel yard used for equipment storage. Currently the storm water is conveyed by sheet flow to a series of swales on the east and south side of the site.



2.2.1.2 Pre-Development Runoff Coefficient

For the 2 year storm event the runoff coefficient is take as 0.25. A 25 percent increase is used for the 100 year storm event resulting in a runoff coefficient of 0.31.

2.2.1.3 Pre-Development Time of Concentration

The time of concentration for the site during pre-development conditions was calculated using a combination of the Airport formula and the Upland Method. The airport formula, developed by the U.S. Department of Transportation’s Federal Aviation Administration (FAA), is more commonly used for rural development where the runoff coefficient is less than 0.40. The Uplands Method is commonly used when calculating flow velocity for shallow concentrated overland flow. It is considered that after the first 50 metres of sheet flow, the runoff will become more concentrated and flow along preferred flow channels.

TR55 Urban Hydrology for Small Watersheds, Second Ed, June 1986, provides a maximum limit of 300 ft for sheet flow. Research by USDA NRCS shows that this is an over estimate and many sources show that this length should be reduced. William Merkel, Hydraulic Engineer USDA, NRCS, National Water and Climate Center Beltsville, MD December 17, 2001. For this reason, the overland flow or sheet flow length was reduced to 50 metres.

Airport Formula:

$$t_{ca} = \frac{3.26 \times (1.1 - C) \times l_c^{0.5}}{S^{0.33}}$$

Where C = Runoff Coefficient = 0.25
 l_c = length of flow path = 50 m
 S = Slope of flow path percent = 0.5 for this site.

Upland Method

$$V = K \times \sqrt{S}$$

$$t_{cu} = \frac{l_c}{60 \times V}$$

The K intercept was obtained from the Comprehensive Urban Hydrologic Modeling Handbook for Engineers and Planners First Edition 2006, By Nicklow/Boulos/Muleta Chapter 5. K is the intercept coefficient for shallow concentrated flow and is 0.213 m/s for grass covered surfaces.

For this site, the longest distance of travel for rainfall landing on the site is 200 metres. Since the first 50 metres is considered sheet flow, the remaining 150 metres will be along preferred channels. As such $l_c = 150$ m.



$$t_c = t_{ca} + t_{cu}$$

For this site, $t_c = 24.6 + 16.6 = 41.2$ rounded to 41 minutes

Calculations are presented in Appendix A.

2.2.2 Post-Development Details

2.2.2.1 Post-Development Site Conditions

As previously stated, the site will be developed as a light industrial warehouse site. The proposed site will contain two warehouse buildings. Building #2 will be warehouse building with an accessory office having a combined area 2,174 square metres. Building #3 will be a storage facility with an area of 2,174 square metres.

There will be a parking area in front of Building #2. This area will be paved. On the north side of Building #3 there will be a concrete apron. Runoff originating at Building #2 and Building #3 will be directed by sheet flow to the swales to the east and south. The remaining portion of the site will be surfaced with granular material.

The existing east and south swales are to be modified to accommodate the entrances. At the entrances, culverts have been proposed, and suitably sized to allow stormwater from the east swale to flow into the south swale before being discharged to the roadside ditch. In addition, the swales have been resized to accommodate the storage requirements for the proposed development.

The swales will discharge at a controlled rate to the roadside ditch along Bank Street.

2.2.2.2 Post-Development Uncontrolled Areas

There are no uncontrolled areas within Catchment 2, where runoff flows from the site without restriction. The entirety of the development will be controlled.

2.2.2.3 Post-Development Runoff Coefficient

Post development runoff coefficients were calculated for the development area. For impermeable surfaces (asphalt, sidewalks and the building roof) a runoff coefficient of 0.9 was used. For any grassed areas, a runoff coefficient of 0.2 was used. For the 100 year storm event a 25% increase in the runoff coefficient was used. The overall runoff coefficient was calculated using a weighted average by area. The Post Development runoff coefficients are summarized in Table 2-1 below.



Table 2-1: Summary of Post-Development Site Conditions

Description	Runoff Coefficient		Area (ha)
	2-year	100-year	
Controlled			3.578
Roof & Asphalt	0.90	1.00	1.096
Gravel	0.70	0.88	1.578
Grass	0.25	0.31	0.903
<i>Controlled Area Weighted Average C</i>	<i>0.65</i>	<i>0.77</i>	
<i>Controlled area Impervious (percentage)</i>	<i>63%</i>		

For the controlled area the resultant runoff coefficients are 0.65 for the 2 year event and 0.77 for the 100 year event.

2.2.3 Storm Analysis Variable Summary

Table 2-2: Storm Analysis Variable Summary

	Catchment Area Label	Area ha.	Runoff Coefficient		Time of Concentration
			2 year	100 year	
Pre-Development	N/A	3.578	0.25	0.31	41 min
Post-Development	CA1	3.578	0.65	0.77	N/A

2.3 SWM Quantity Control

2.3.1 Peak Flow Calculation Method

Peak flow for runoff quantities for the pre-development and post-development stages of the project were calculated using the rational method. The rational method is a common and straightforward calculation, which assumes that the entire drainage area is subject to uniformly distributed rainfall. The formula is:

$$Q = \frac{CiA}{360}$$

Where

- Q is the Peak runoff measured in ***m³/s***
- C is the Runoff Coefficient, **Dimensionless**
- A is the runoff area in ***hectares***
- i* is the storm intensity measure in ***mm/hr***



All values for intensity, *i*, for this project were derived from IDF curves provided by the City of Ottawa. The formulas for each are:

2 Year Event

$$i = \frac{732.951}{(t_c + 6.199)^{0.810}}$$

100 Year Event

$$i = \frac{1735.688}{(t_c + 6.014)^{0.820}}$$

Where:

t_c is time of concentration, in minutes

i is the storm intensity in mm/hr

For a 41 minute time of concentration the above formula provides the following intensities:

2 Year Event
32.30 mm/hr

100 Year Event
73.83 mm/hr

2.3.1.1 Pre-Development Runoff

Using the Rational Method with the above calculated runoff coefficients and storm intensities, the pre-development runoff rates for the 2-year and 100-year storms are:

$$2 \text{ year} = 0.25 \times 32.30 \times 3.578 / 360 = 0.0803 \text{ m}^3/\text{s} = 80.3 \text{ L/s}$$

$$100 \text{ year} = 0.31 \times 73.83 \times 3.578 / 360 = 0.2277 \text{ m}^3/\text{s} = 228 \text{ L/s}$$

2.3.1.2 Allowable Release Rate

As previously indicated the post development release rate will be restricted. Those requirements, the relevant authority for each restriction and the allowable release rates are summarized in the table below.

Table 2-3: Allowable Release Rates

Storm Event	Restriction	Authority	Allowable Release Rate
2 Year	50% of Pre	Shields Creek Subwatershed Study	40.2 L/s
100 Year	2 Year Pre	City of Ottawa	80.3 L/s

2.3.2 Post Development Restricted Flow and Storage

In order to meet the stormwater quantity control restriction, the post development runoff rate from the controlled areas of the site cannot exceed the allowable release rate into the roadside



ditch for each design storm event. Runoff in excess of the allowable release rate will be detained and temporarily stored on site in the east and south swales, to be released at a controlled rate during and following a storm event.

The stormwater management calculation sheets included in Appendix A were generated to determine the maximum storage requirement:

- On Sheet 3: Required Storage vs. Release Rate: The storage requirement for a series of design storms was determined as a function of the release rate from the catchment area for each return period. For the purposes of this sheet, each duration of the respective design storms (2 yr, 100 yr) is considered to be an individual design storm.
- On Sheet 4: Outlet Control Design Sheet – Treatment Swale: The available storage volume is calculated with respect to the ponding level elevation in the treatment swale. The discharge rate from the treatment swale is calculated from the combination of the outlet flow from the outlet control structure and infiltration. The discharge rate is a function of the head on the outlet control structure.
- On Figure 1: Discharge-Storage Curve: The storage discharge curve chart was generated to overlay the maximum storage requirement vs. discharge rate curve for each return period (calculated on the required storage vs. release rate sheet) on the available storage volume vs. discharge rate curve (calculated on the outlet control design sheet). The point where the curves cross provides the maximum storage volume and discharge rate for each return period considered.
- On Figure 2: Stage-Storage Curve: The storage vs. elevation curve (calculated on the outlet control design sheet) was plotted vs. the maximum storage volume (calculated on Figure 1: Discharge-Storage Curve) to find the level of ponding for each return period considered.

2.3.2.1 SWM System Description

In order to achieve the allowable controlled area storm water release rates, storm water runoff will be directed to the swales along the south and east sides of the site. Runoff from these swales will be discharged at a controlled rate to the road side ditch along the west side of Bank Street. The proposed swales are shown on Kollaard Associates drawing number 230156-GR *Grading and Drainage Plan*. Each swale will be designed with a wide flat bottom to maximize the flow width and available storage at shallow depths. The filter berm is designed to retain and provide treatment for the first flush and for the quality control volume. During a 2 year storm event, the storage volume in front of the sand filter berm will fill. Once this available storage is occupied, the sand filter berm will be overtopped and the release rate from the storage areas will be controlled by the use of outlet structures.

The proposed stormwater storage for catchment area CA2 consists of a 200 metre long by 9 metre wide flat bottomed swale along the south side of the site. The stormwater storage for CA2 also consists of a 75 metre long 3 metre wide flat bottomed swale along the east side of the site. Upstream of the swale on the east side of the site is another swale that is



approximately 22 metres long and 2 metres wide. This swale is considered only for conveyance and is omitted in further calculations. The swale along the east side of the site outlets to the south swale. The south swale discharges to the road side ditch along Bank Street. The bottom of these swales have longitudinal slopes of 0.3 percent in order to maximize sedimentation and infiltration. The lowest swale elevation is 93.40 metres. The south side of the south storage swale has an elevation of 94.30 metres to provide free board to the adjacent property during a 100 year storm event. The east side of the east storage swale has an elevation of 94.30 metres. Overflow from this swale to the east would be to the road side ditch. The inside edges or north and west sides of the swales adjacent the granular surfaced yard range in elevation from 94.3 to 94.5 metres. Both swales are to have grass side slopes with crushed concrete rubble lining the bottom. These swales are not adjacent the proposed buildings.

2.3.2.2 Outlet Control

The outlet will be controlled in two stages. First the sand filter has been sized such that the runoff is detained and released through horizontal filtration into a perforated HDPE pipe encased in clear stone. At a ponding depth of 0.45 m the runoff will overtop the sand filter and be allowed to flow directly through the clear stone and through the perforated HDPE pipe. This pipe discharges to a concrete structure (STM-MH1) which in turn discharges to a solid HDPE pipe which conveys the water to the roadside ditch. The details of the system are:

- The sand filter is located in the south east corner of the swale. It has a length of 25 m, a height of 0.45 m and a minimum width of 0.5 m.
- On the south side of the sand filter is a 450mm perforated HDPE pipe with a longitudinal slope of 0.5%.
- A 1200 mm concrete structure will be installed between the treatment swale and the roadside ditch.
- A 200 mm pipe will be fitted to the concrete structure with an invert elevation of 93.4 m.

2.3.2.3 Elevation, Storage and Discharge Relationship

The design outlet control for the stormwater treatment swale will result in the stage-storage-discharge relationship as indicated in Table 2-4 below:



Table 2-4: Elevation, Storage and Discharge Relationships

Stage (Elevation) m	Quantity Storage m ³	Sand Filter Discharge L/sec	Orifice Discharge L/sec	Total Discharge L/sec
94.30	1812.4	0.00	79.21	79.21
94.20	1472.4	0.00	74.68	74.68
94.10	1148.0	0.00	69.86	69.86
94.00	849.2	0.00	64.67	64.67
93.90	582.0	0.00	59.04	59.04
93.80	361.3	6.45	0.00	6.45
93.70	195.0	2.45	0.00	2.45
93.60	82.4	0.82	0.00	0.82
93.50	16.4	0.16	0.00	0.16
93.40	0.0	0.00	0.00	0.00

As previously discussed, the modified rational method was utilized to determine the maximum storage requirement based on the storage discharge relationship for the controlled area. The calculation tables are included in Appendix A.

2.3.2.4 Summary

The calculation tables provided in Appendix A include calculations for the stormwater storage design in the controlled area. The maximum discharge rates and storage requirements and ponding depths for the design storms are as summarized in Table 2-5 below.

Table 2-5: Maximum Discharge Rate, Storage Requirement and Ponding Depth

Return period	Allowable Release Rate	Actual Release rate	Required Storage	Available Storage	Required Storage Depth	Available Storage Depth
(years)	(L/s)	(L/s)	(m ³)	(m ³)	(m)	(m)
2	40.2	25	500	1812	0.46	0.90
100	80.3	73	1310	1812	0.75	0.90

From the Calculations in Appendix A as summarized in the above table, the actual release rate from the storage swale will be much less than the allowable release rate for each design storm event.

It is noted that the storage volume required to ensure the quality control criteria is met in conjunction with the flow restriction provided by the filter will result in over restriction of the flow rate from the storm pond when compared to the allowable release rates previously calculated.



2.4 Stormwater Quality Control

As previously indicated, during a pre-consultation with the City of Ottawa, the following quality control criteria was provided:

- An enhanced level of treatment is to be provided for runoff from the site, corresponding to 80% total suspended solids removal.

Stormwater treatment of 80% TSS removal will be provided for by the use of a sand filter in combination with pre-treatment utilizing Best Management Practices (BMPs) including the use of low sloped swales.

2.4.1 Quality Control - Filtration

The main consideration for quality control is the runoff from the yards where vehicles are traveling on the site. Runoff from these asphalt and gravel surfaces can accumulate pollutants such as sediment, nutrients (nitrogen and phosphorus) as well as oil, grease and heavy metals.

Quality Control for Catchment 2 will be provided by providing temporary detention of the entire volume of runoff (specified in the MOE Stormwater Manual) for quality control upstream of a sand filter in the south swale. Discharge of this quality control volume will be through the sand filter only. The runoff entering the storage swale in front of the sand filter will be pre-treated by means of sedimentation in the grass lined swales, to prolong the life of the sand filter. The south storage swale has been designed to outlet the quality storage volume horizontally through the sand filter. Stormwater will infiltrate through the sand filter into a subdrain. The perforated subdrain discharges to the roadside ditch at Bank Street.

The proposed filter has been sized based on the space available for the filter. The flow rate through the filter was calculated and the drawdown time was determined based on the volume of the quality storage in the catchment.

The filter will be protected on the surface by a 100 mm thick layer of rip rap. A non-woven geotextile filter fabric (such as Terrafix 360R or an approved alternative) will be placed between the sand and the layer of riprap. The filter fabric will also be extended beneath and beside the filter to prevent contamination of the filter sand from the underlying native material. This fabric offers medium tensile strength at high elongation and good filtration, coupled with high permeability to allow for proper filtration, while holding the filter sand in place as designed. The Terrafix Geosynthetics Inc. specification sheet can be found in Appendix B.

2.4.1.1 Catchment CA2 Volumetric Sizing

When considering storage volume for quality control the Ministry of Environment Stormwater Management Planning and Design Manual (March 2003)(SWMPDM) provides guidance on appropriate sizing for water storage in Table 3.2. Appropriate sizing was calculated based on 80% TSS removal by infiltration. The impervious ratio for CA2 = 0.63. From Table 3.2 by



extrapolation, the storage requirement is 32.7 m³/ha. 3.578 ha x 32.7 m³/ha gives a total storage requirement of 117.2 m³.

Further in section 4.6.7 the MECP recommends that when using filtration for quality control, the filter should not be bypassed “below or at the peak runoff from a 4 hour 15 mm design event.” For the sake of simplicity, and due to the decision to retain the entire 2 year storm event, it is assumed that the filter will treat the entire volume of a 15 mm storm event. Multiplying 15 mm by the runoff coefficient of 0.65 for Catchment 2 and then multiplying by the area gives a volume of 349 m³.

As shown in Appendix A, there is a total storage volume for quality control purposes of 465 m³ below the top of the sand filter. As such the filter is appropriately sized.

2.4.2 Discharge through Sand Filter and Infiltration

The sand filter will be placed in front of the outlet culverts and will have a depth of 0.45 metres, and length and width of 25m x 2m. The proposed filter will be a horizontal sand filter and will be constructed with a minimum filter thickness (width) of 0.5m (Refer to the details plan 230156-Details for a Cross section showing the filter width). The sand filter will be constructed of a medium grained sand having a percolation rate of T = 2 min/cm and a maximum of 3 percent passing the 0.08 millimetre sieve size. According to the MOE Stormwater Manual, the seepage rate through a sand filter is to be calculated by using Darcy's Law and is equal to the projected surface area of the weir x coefficient of permeability x (hydraulic gradient across the filter). The hydraulic gradient was calculated as the head across the filter divided by the average length of the flow path through the filter.

A coefficient of Permeability of 3600 mm/h was used in the Darcy Equation to represent the actual coefficient of permeability for the sand in the filter. This permeability was derived from the values given in Table 2: Approximate Relationship of Coarse grained Soil Types to Permeability and Percolation Time in the 2012 Building Code “Supplementary Standards -6: Percolation Time and Soil Descriptions”. The percolation rate “T” time of the soil to be used in the filter is 2 mins/cm. This corresponds to a coefficient of permeability of 0.1 cm/sec (or 3600 mm/h). This is based on the specified sand material to be used in the sand filter as indicated on Kollaard Associates Inc. drawing #230156 - GR.

From the geotechnical report prepared by Kollaard Associates Inc, the underlying soils consist of compact to dense glacial till with about 40 percent silt/clay and 45 percent sand sized particles. From SB-6 Table 2, the coefficient of permeability for this glacial till would be 1.0 x 10⁻⁷ m/sec.

The table quoted above shows the following; the fourth column has been added and is different from the quoted table.



Soil Type	Coefficient of Permeability $K - \text{cm/sec}$	Percolation Time $T - \text{mins/cm}$	Coefficient of Permeability $K - \text{m/sec}$
S.M.	$10^{-3} - 10^{-5}$	8 - 20	$10^{-5} - 10^{-7}$

The value provided in the table for a percolation rate (T) of 2 mins/cm is 0.1 cm/sec or 3600 mm/hr.

The flow rate through the sand filter would be:

$$Q = A k i$$

Where A = cross-sectional area of filter

k = coefficient of permeability = 1×10^{-3} m/s

i = hydraulic gradient = d/L where d is the ponding depth and L is the horizontal length of flow

The flow rate through the bottom of the swales would be:

$$Q = A k i$$

Where A = surface area of the pond

k = coefficient of permeability = 1×10^{-7} m/s

i = $(d/(h+d))$ where d is the upper 1.0 m of glacial till below the swale and h is the ponding depth

Calculations are shown in Appendix A showing the total drawdown as a function of head pressure on both the sand filter and infiltration. The total drawdown time is 47 hours from the maximum storage requirement for a 100 year storm event to a depth of 10 cm. It is considered that by lining the storage swale with crushed concrete, this final level of ponding will not be a concern. This is further discussed in Section 2.4.3.

2.4.3 Best Management Practices

Section 4.5.9 of the MOE Stormwater Management Planning and Design Manual (dated March 2003), discusses the use of grassed swales as a form of lot level and conveyance controls for stormwater management. This section promotes the use of shallow low gradient swales as opposed to deep narrow swales. Swales are also more effective for water quality purposes if the slope is less than 1% and the velocity less than 0.5m/s. These design aspects are incorporated into the detailed design of the development.

City of Ottawa Sewer Design Guidelines indicate that all swales with slopes of less than 1.5% must have a perforated sub-drain as per City of Ottawa Standard Detail S29. This standard detail is titled *Perforated Pipe Installation For Rear Yard and Landscaping Applications*. This detail specifies a surface layer with a thickness of 100 mm followed by 300 mm of approved native backfill then by a clear stone drainage layer with a perforated pipe. The clear stone drainage layer has a minimum thickness of 600 mm. The perforated pipe has a diameter of 250 mm and is located a minimum of 75 mm from the bottom of the trench. This sub-drain or



perforated pipe extends along the bottom of the swale to an outlet. In the case where the perforate pipe is used for rear yard drainage and landscaping purposes in an urban setting, the outlet for the perforated pipe is typically a storm sewer.

The purpose of the minimum swale slope requirement and mitigating detail where the minimum slope cannot be met due to physical limitations of a site is to ensure that there is no long term ponding within the swale. Long term ponding negatively affects vegetation and results in stagnant water leading to mosquito habitat and odour.

It is considered, however, that there is no outlet for a sub-drain at this site due to the limited elevation difference between the bottom of the storage swale and the immediate receiving body which is the roadside ditch along Bank Street. The bottom of the storage swale elevation is set at 93.4 metres and the existing roadside ditch elevation at the outlet location varies from 93.2 to 93.3 metres. The physical limitations of the site make the installation of a subdrain below the swales unfeasible.

In order to reduce the potential for improper drainage of the swales and the potential for surface ponding, the bottom of the swales will be lined with crushed concrete rubble. The crushed concrete will have a minimum thickness of 0.3 metres. As a result of the crushed concrete, any potential ponding within the swales will be below the ground surface.

Best Management Practices shall be implemented as follows to reduce transport of sediments and promote on site ground water recharge.

- a) Minimum slope on the granular yard area and coarsely graded granular material to promote infiltration of rainwater through the yard area.
- b) Discharge roof leaders to yards for natural infiltration / evaporation. Roof leaders or roof drainage will not be connected to a storm sewer system. They will discharge onto the ground adjacent to the buildings and travel through low gradient swales which will promote infiltration into the ground.
- c) Servicing via swales and culverts instead of storm sewers. The drainage system for the development consists of swales and culverts (where needed) without the use of storm sewers. This will promote surface water infiltration.

The contractor shall implement BMP's to provide for protection of the area drainage system as further detailed in Section 3 of this report.

2.5 Low Impact Development (LID) Considerations

The proposed development uses the following LID techniques where appropriate:

- Vegetated Filter Strips/Enhanced Grass Swales: Storm runoff is directed over grassed areas toward and enhanced grass swale before release to a roadside ditch. Grassed areas provide good initial filtration of storm runoff and provide time for runoff to infiltrate naturally.



- **Reduced Lot Grading:** The site grading plan contains shallow grading which reduces the speed at which storm water runs into the above treatment facility. This improves the effectiveness of the treatment facility and reduces downstream erosion.

The document titled 'Low Impact Development Technical Guidance Report – Implementation in Areas with Potential Hydrogeological Constraints' gives specific guidance to areas where specific LID implementations may not be appropriate. Specifically on this site, City of Ottawa soil mapping shows potential for shallow depth to bedrock. Boreholes on site indicate bedrock is at least 2 m below grade on this site which gives an appropriate soil depth for the application of infiltration as a LID technique.

2.6 Thermal Considerations

The proposed development is within the Shield's Creek Watershed. The Shield's Creek Subwatershed study requires consideration for the effects of development on increased temperature of the stormwater runoff.

The MOE Manual in section 4.4 states that all types of urban development will result in an increase in water temperature.

The affects of the proposed development will be mitigated by the following design elements:

- The majority of the site will be surfaced with granular. The lighter colour of the granular material does not warm rainwater as much as an asphaltic concrete surface;
- The granular yard area will have a relatively porous granular structure increasing infiltration and decreasing runoff into storage swales;
- There is no proposed surface storage on the yard, laneway or parking areas;
- The bottom of the storage swales will be lined with clear crushed concrete rubble which will prevent long term ponding within the swales;
- Discharge is to the roadside ditch along the west side of Bank Street.

2.7 Groundwater Recharge

The Shields Creek Subwatershed Study provides guidance on Infiltration / Groundwater Protection in section 6.3.4.7. This section states that existing infiltration levels are to be maintained as part of a stormwater management plan for future development to protect the groundwater resources. Preliminary Infiltration targets have been developed and summarized in Table 6.3.2. Actual targets would be expected to have ranges on the order of 10% on either side of the specified rate in the table.

2.7.1 Infiltration Target

From the geotechnical report prepared by Kollaard Associates Inc, the underlying soils consist of compact to dense glacial till with about 40 percent silt/clay and 45 percent sand sized particles. From Table 6.3.2, a glacial till soil type would have a target infiltration rate of 50 –



100 mm/yr. Allowing 10% on either side of this results in a maximum expected infiltration rate of 110 mm/yr for the site.

2.7.2 Ste Infiltration

Based on historical climate data for the Ottawa Area, there are, on average, approximately 46 days per year with a rainfall of between 5 and 10 mm, approximately 20 days per year with a rainfall of between 10 and 25 mm and 5 days per year with a rainfall of greater than 25 mm. The total average annual rainfall for the City of Ottawa Area is 733 mm.

As previously indicated, Catchment 2 has a runoff coefficient of 0.65.

The runoff coefficient (C) is a dimensionless coefficient relating the amount of runoff to the amount of precipitation received. It is a larger value for areas with low infiltration and high runoff (pavement, steep gradient), and lower for permeable, low gradient areas (landscape, coarse graded granular). As such a runoff coefficient of 0.65 indicates that 65 percent of the precipitation received will runoff the site and 35 percent of the precipitation received will infiltrate.

Based on the runoff coefficients for the site and the average annual precipitation, the expected infiltration for Catchment 2 is 257 mm/yr which is greater than the maximum expected infiltration rate.

2.8 Operation and Maintenance

2.8.1 Outlet Structures and Culverts

The swales should be visually inspected on a semi-annual basis and following significant storm events. The inspection should include a visual assessment for the presence of noxious weeds, health of vegetation, erosion, debris and garbage, vandalism and general structural integrity of the swales and outlet structures. A written record of the inspection should be made and any deficiencies identified should be corrected. The method by which the deficiency was addressed should also be recorded.

Removal of accumulated sediment from the swales should be conducted when the accumulation of the sediment begins to cause long term surface ponding (more than 2 days) within the swales and/or the drainage patterns along the swales are altered. The sand filters should be replaced when the drawdown time noticeably increases.

It is expected that observations should be made of the stormwater swales during and after significant rainfall events. If the pond appears to be noticeably deeper than expected or it appears that it takes noticeably longer than expected for the water to completely leave the swales the engineer should be notified of the observations. At this point the engineer could make an assessment of the material in the upper portion of the filter. If the assessment



indicates that the filter has become compromised with sediment, the filter will require maintenance.

The outer layer of the filter material (e.g., 0.1 to 0.15 m) should be removed and replaced with clear material when accumulated sediment is removed from the filter. The protective riprap may be reused if free of silt/sediment.

3 EROSION AND SEDIMENT CONTROL

The owner (and/or contractor) agrees to prepare and implement an erosion and sediment control plan at least equal to the stated minimum requirements and to the satisfaction of the City of Ottawa and South Nation Conservation, appropriate to the site conditions, prior to undertaking any site alterations (filling, grading, removal of vegetation, etc.) and during all phases of site preparation and construction in accordance with the current best management practices for erosion and sediment control.

It is considered that the responsibility of implementing the sediment and erosion control measures is that of the Landowner. The Landowner is to make the contractor retained to complete the works aware of the sediment and erosion control measures and to ensure the contractor installs and maintains them.

In order to limit the amount of sediment carried in stormwater runoff from the site during construction, it is recommended to install a silt fence along the sides of the property as shown in Kollaard Associates Inc. drawing #230156 – ESC – Erosion and Sediment Control Plan.

In order to limit the amount of sediment carried in stormwater runoff from the site during construction, it is recommended to install a silt fence along the east side of the development area immediately adjacent the existing vegetated surface of the road side ditch. The silt fence may be polypropylene, nylon, and polyester or ethylene yarn.

If a standard filter fabric is used, it must be backed by a wire fence supported on posts not greater than 2.0 m apart. Extra strength filter fabric may be used without a wire fence backing if posts are not greater than 1.0 m apart. Fabric joints should be lapped at least 150 mm (6") and stapled. The bottom edge of the filter fabric should be anchored in a 300 mm (1 ft) deep trench, to prevent flow under the fence. Sections of fence should be cleaned, if blocked with sediment and replaced if torn.

A mud mat is to be installed at the construction access to the site. Details of the mud mat are provided on Kollaard drawing 230156-ESC. The mud mat is to consist of a 20 metre long by 6 m wide pad constructed with 50 mm diameter clear stone.

The exposed landscaped areas of the site should be mulched and seeded with a rapid growing grass mixture or sodded as soon as possible. The proposed asphaltic concrete surfaced areas should be surfaced as soon as possible.



The silt fences should only be removed once the site is stabilized and vegetation is established. These measures will reduce the amount of sediment carried from the site during storm events that may occur during construction.

4 CONCLUSIONS

This report addresses the stormwater management requirements for the proposed development expansion on Bank Street. Based on the analysis provided in this report, the conclusions are as follows:

- Stormwater management from a quantity control perspective for the proposed development will be achieved by restricting the runoff rate from the site by means of a sand filter within the proposed storage swales and an orifice within the outlet structure to less than or equal to the allowable release rates.
- Stormwater management from a quality control perspective will be provided by means of sedimentation within the storage swale followed by filtration through a horizontal sand filter.
- Infiltration of precipitation will be maintained to meet the requirements of the Shields Creek Sub-watershed Study by using minimum gradients across the granular yard area. The granular yard area will be constructed with coarse graded granular to promote infiltration.
- During all construction activities, erosion and sedimentation shall be controlled.

We trust that this report provides sufficient information for your present purposes. If you have any questions concerning this report or if we can be of any further assistance to you on this project, please do not hesitate to contact our office.

Sincerely,

Kollaard Associates, Inc.



Steven deWit, P.Eng.



Appendix A: Stormwater Management Model

Sheet 1 – PRE DEVELOPMENT RUNOFF RATES

Sheet 2 – POST DEVELOPMENT FLOWS

Sheet 3 – CA2 - REQUIRED STORAGE VS. RELEASE RATE

Sheet 4 – CA2 - OUTLET CONTROL STRUCTURE DESIGN SHEET

Figure 1 – Discharge-Storage Curve

Figure 2 – Stage-Storage Curve



Kollaard Associates

Engineers

210 Prescott Street, Unit 1

P.O. Box 189

Kemptville, Ontario K0G 1J0

- Civil •
- Geotechnical •
- Hydrogeological •
- Inspection Testing •
- Septic Systems Grading •
- Structural • Environmental •

APPENDIX A: STORMWATER MANAGEMENT MODEL

SHEET 1: PRE DEVELOPMENT RUNOFF RATES

Client: CAMM Warehousing and Rentals Inc

Job No.: 230156

Location: 6622 Bank Street, Ottawa, Ontario

Date: October 2, 2024

PRE DEVELOPMENT FLOW

Runoff Coefficient Equation

$$C = (A_{\text{hard}} \times 0.9 + A_{\text{soft}} \times 0.2) / A_{\text{tot}}$$

Pre Dev run-off Coefficient "C"

Area (Ha)	Surface	Ha	2 Year Event		100 Year Event	
			"C"	C _{avg}	"C" x 1.25	C _{100 avg}
Total 3.578	Asphalt/Roof	0.000	0.90	0.25	1.00	0.31
	Gravel	0.000	0.40		0.50	
	Grass/Field	3.578	0.25		0.31	

*C value multiplied by 1.25 to a max. Of 1.00 for 100 year event

2 Year Event			
Pre Dev.	C	Intensity	Area
5 Year	0.25	32.30	3.578
2.78CIA= 80.32			
80 L/s			

**Use a 41 minute time of concentration

Total Release: 80.3 L/s

100 Year Event			
Pre Dev.	C	Intensity	Area
100 Year	0.31	73.83	3.578
2.78CIA= 227.66			
228 L/s			

**Use a 41 minute time of concentration

Total Release: 227.7 L/s

ALLOWABLE RELEASE RATE

Storm Event	L/s	Criterion
2 Year	40.2	50% of 2 Year Pre
100 Year	80.3	2 Year Pre

Pre Dev Time of Concentration "t_c"

$t_{ca} = \frac{3.26 \times (1.1 - C) \times l_c^{0.5}}{S^{0.33}}$	C = Runoff Coefficient	0.25
	l _c = length of flow path	50
	S = Slope of flow path	0.5
$t_c = 24.63$		

Equations:

Flow Equation

$$Q = 2.78 \times C \times l \times A$$

Where:

C is the runoff coefficient

l is the intensity of rainfall, City of Ottawa IDF

A is the total drainage area

Runoff Coefficient Equation

$$C = (A_{\text{hard}} \times 0.9 + A_{\text{soft}} \times 0.2) / A_{\text{tot}}$$

	L(m)	V(m/s)	t _c
Grass /Field	150	0.15	16.60

Total t_c 41.23



Kollaard Associates

Engineers

210 Prescott Street, Unit 1

P.O. Box 189

Kemptville, Ontario K0G 1J0

- Civil ●
- Geotechnical ●
- Hydrogeological ●
- Inspection Testing ●
- Septic Systems Grading ●
- Structural ● Environmental ●

APPENDIX A: STORMWATER MANAGEMENT MODEL

SHEET 2: POST DEVELOPMENT FLOWS

Client: CAMM Warehousing and Rentals Inc

Job No.: 230156

Location: 6622 Bank Street, Ottawa, Ontario

Date: October 2, 2024

CA2

Runoff Coefficient Equation

$$C = (A_{\text{hard}} \times 0.9 + A_{\text{soft}} \times 0.2) / A_{\text{tot}}$$

Post Dev run-off Coefficient "C"

Area (Ha)	Surface	Ha	5 Year Event		100 Year Event	
			"C"	C _{avg}	"C" x 1.25	C _{100 avg}
Total 3.578	Roof/Asphalt	1.096	0.90	0.65	1.00	0.77
	Gravel	1.578	0.70		0.88	
	Landscape/ Swales	0.903	0.25		0.31	

Post Dev Free Flow

2 Year Event

Post Dev.	C	Intensity	Area
2 Year	0.65	52.03	3.578
2.78CIA= 336.41			
336 L/S			

**Use a 20 minute time of concentration for 5 year

100 Year Event

Post Dev.	C*	Intensity	Area
100 Year	0.77	119.95	3.578
2.78CIA= 918.71			
919 L/S			

**Use a 20 minute time of concentration for 100 year

*C value multiplied by 1.25 for 100 year event

Equations:

Flow Equation

$$Q = 2.78 \times C \times I \times A$$

Where:

C is the runoff coefficient

I is the intensity of rainfall, City of Ottawa IDF

A is the total drainage area

UNRESTRICTED DESIGN FLOW RATE

2 Year Event	336.4
100 Year Event	918.7

APPENDIX A: STORMWATER MANAGEMENT MODEL
SHEET 3: CA2 - REQUIRED STORAGE VS. RELEASE RATE

Client: CAMM Warehousing and Rentals Inc
 Job No.: 230156
 Location: 6622 Bank Street, Ottawa, Ontario
 Date: October 2, 2024

CA2 Post Dev run-off Coefficient "C"

Area (Ha)	Surface	Ha	2 Year Event		100 Year Event	
			"C"	C _{avg}	"C" x 1.25	C _{100 avg}
Total	Roof/Asphalt	1.096	0.90	0.65	1.00	0.77
3.578	Gravel	1.578	0.70		0.88	
	Landscape / Swales	0.903	0.25		0.31	

REQUIRED STORAGE VERSUS RELEASE RATE FOR 2 YEAR STORM

Runoff Coefficient, C =	0.65	Duration Interval (min) =	10
Drainage Area (ha) =	3.578	Release Rate Start (L/s) =	0
Return Period (yrs) =	2	Release Rate Interval (L/s) =	20

Release Rate -->			0	20	40	60	80	100	120	140	160	180
Duration (min)	Rainfall Intensity (mm/hr)	Peak Flow (L/sec)	Storage Required (m ³)									
0	167.2	1081.2	0.0	0.0	0.0	0.0	0.0	0.0	0.0	0.0	0.0	0.0
10	76.8	496.6	297.9	285.9	273.9	261.9	249.9	237.9	225.9	213.9	201.9	189.9
20	52.0	336.4	403.7	379.7	355.7	331.7	307.7	283.7	259.7	235.7	211.7	187.7
30	40.0	258.9	466.0	430.0	394.0	358.0	322.0	286.0	250.0	214.0	178.0	142.0
40	32.9	212.5	510.0	462.0	414.0	366.0	318.0	270.0	222.0	174.0	126.0	78.0
50	28.0	181.3	543.9	483.9	423.9	363.9	303.9	243.9	183.9	123.9	63.9	3.9
60	24.6	158.8	571.6	499.6	427.6	355.6	283.6	211.6	139.6	67.6	-4.4	-76.4
70	21.9	141.7	595.0	511.0	427.0	343.0	259.0	175.0	91.0	7.0	-77.0	-161.0
80	19.8	128.2	615.4	519.4	423.4	327.4	231.4	135.4	39.4	-56.6	-152.6	-248.6
90	18.1	117.3	633.4	525.4	417.4	309.4	201.4	93.4	-14.6	-122.6	-230.6	-338.6
Maximum Storage Rate =			633.4	525.4	427.6	366.0	322.0	286.0	259.7	235.7	211.7	189.9

REQUIRED STORAGE VERSUS RELEASE RATE FOR 100 YEAR STORM

Runoff Coefficient, C =	0.77	Duration Interval (min) =	10
Drainage Area (ha) =	3.578	Release Rate Start (L/s) =	30
Return Period (yrs) =	100	Release Rate Interval (L/s) =	15

Release Rate -->			30	45	60	75	90	105	120	135	150	165
Duration (min)	Rainfall Intensity (mm/hr)	Peak Flow (L/sec)	Storage Required (m ³)									
0	398.6	3053.0	0.0	0.0	0.0	0.0	0.0	0.0	0.0	0.0	0.0	0.0
10	178.6	1367.6	802.6	793.6	784.6	775.6	766.6	757.6	748.6	739.6	730.6	721.6
20	120.0	918.7	1066.5	1048.5	1030.5	1012.5	994.5	976.5	958.5	940.5	922.5	904.5
30	91.9	703.6	1212.5	1185.5	1158.5	1131.5	1104.5	1077.5	1050.5	1023.5	996.5	969.5
40	75.1	575.5	1309.3	1273.3	1237.3	1201.3	1165.3	1129.3	1093.3	1057.3	1021.3	985.3
50	64.0	489.8	1379.5	1334.5	1289.5	1244.5	1199.5	1154.5	1109.5	1064.5	1019.5	974.5
60	55.9	428.1	1433.2	1379.2	1325.2	1271.2	1217.2	1163.2	1109.2	1055.2	1001.2	947.2
70	49.8	381.3	1475.6	1412.6	1349.6	1286.6	1223.6	1160.6	1097.6	1034.6	971.6	908.6
80	45.0	344.6	1510.0	1438.0	1366.0	1294.0	1222.0	1150.0	1078.0	1006.0	934.0	862.0
90	41.1	314.9	1538.3	1457.3	1376.3	1295.3	1214.3	1133.3	1052.3	971.3	890.3	809.3
100	37.9	290.3	1561.8	1471.8	1381.8	1291.8	1201.8	1111.8	1021.8	931.8	841.8	751.8
110	35.2	269.6	1581.5	1482.5	1383.5	1284.5	1185.5	1086.5	987.5	888.5	789.5	690.5
120	32.9	251.9	1598.0	1490.0	1382.0	1274.0	1166.0	1058.0	950.0	842.0	734.0	626.0
130	30.9	236.7	1611.9	1494.9	1377.9	1260.9	1143.9	1026.9	909.9	792.9	675.9	558.9
140	29.2	223.3	1623.5	1497.5	1371.5	1245.5	1119.5	993.5	867.5	741.5	615.5	489.5
150	27.6	211.5	1633.3	1498.3	1363.3	1228.3	1093.3	958.3	823.3	688.3	553.3	418.3
160	26.2	201.0	1641.3	1497.3	1353.3	1209.3	1065.3	921.3	777.3	633.3	489.3	345.3
170	25.0	191.6	1647.9	1494.9	1341.9	1188.9	1035.9	882.9	729.9	576.9	423.9	270.9
180	23.9	183.1	1653.2	1491.2	1329.2	1167.2	1005.2	843.2	681.2	519.2	357.2	195.2
Maximum Storage Rate =			1653.2	1498.3	1383.5	1295.3	1223.6	1163.2	1109.5	1064.5	1021.3	985.3

APPENDIX A: STORMWATER MANAGEMENT MODEL
SHEET 4: CA2 - OUTLET CONTROL STRUCTURE DESIGN SHEET

Client: CAMM Warehousing and Rentals Inc
 Job No.: 230156
 Location: 6622 Bank Street, Ottawa
 Date: October 2, 2024

Stage, WSE Elev (m)	Comments	Layer Thickness (m)	Layer Length (m)	Main Section			Island Section			Total Quality Storage (m3)	Total Quantity Storage (m3)	Total Quantity Storage (ha*m)	Filtration Information			Filtration Information			Orifice Flow				
				Top Layer Area (m ²)	Bottom Layer Area (m ²)	Layer Volume (m ³)	Top Layer Area (m ²)	Bottom Layer Area (m ²)	Layer Volume (m ³)				Infiltration			Sand Filter Flow			Orifice 1 Flow		Total Discharge from Site (m ³ /sec)		
													Head (m)	Hydraulic Gradient	Infiltration Rate (m3/s)	Head (m)	Flow Path Length (m)	Hydraulic Gradient	Outflow (m3/s)	Head (m)		Orifice Flow (m ³ /sec)	
94.30		0.100	25.000	2814.6	2814.6	281.5	615.7	555.1	58.5		1812.4	0.1812	Percolation Time T (min/cm): 10	Percolation Rate (mm/hr): 0.36	Permeability k (m/s): 1.0E-07	Depth of Layer (m): 1	Filter Width at Base (m): 0.900	Filter Slope (1H:xV): 2.50000	Permeability k (m/s): 1.00E-03	Dia (m): 0.200	Area (mm.): 0.03142	Orifice Invert: 93.400	
94.20		0.100	25.000	2814.6	2623.7	271.9	555.1	495.3	52.5		1472.4	0.1472	0.9	1.9	0.0003						0.900	0.079	0.079
94.10		0.100	25.000	2623.7	2423.9	252.3	495.3	436.3	46.5		1148.0	0.1148	0.8	1.8	0.0003						0.800	0.075	0.075
94.00		0.100	25.000	2423.9	2109.4	226.5	436.3	378.1	40.7		849.2	0.0849	0.7	1.7	0.0002						0.700	0.070	0.070
93.90		0.050	25.000	2109.4	1854.5	99.0	378.1	349.2	18.2		582.0	0.0000	0.6	1.6	0.0002						0.600	0.065	0.065
93.85	Top of Sand Filter	0.050	25.000	1854.5	1619.8	86.8	349.2	320.6	16.7	464.8	464.8	0.0465	0.5	1.5	0.0002						0.500	0.059	0.059
93.80		0.100	25.000	1619.8	1181.0	139.5	320.6	219.1	26.8	361.3	361.3	0.0361	0.4	1.4	0.0001	0.45	0.50	0.90	0.01012		0.450	0.000	0.010
93.70		0.100	25.000	1181.0	774.9	97.1	219.1	98.4	15.5	195.0	195.0	0.0195	0.4	1.4	0.0001	0.40	0.62	0.65	0.00645		0.400	0.000	0.006
93.60		0.100	25.000	774.9	490.4	62.7	98.4	0.0	3.3	82.4	82.4	0.0082	0.3	1.3	0.0001	0.30	0.92	0.33	0.00245		0.300	0.000	0.002
93.50		0.100	25.000	490.4	0.0	16.4	0.0	0.0	0.0	16.4	16.4	0.0016	0.2	1.2	0.0000	0.20	1.22	0.16	0.00082		0.200	0.000	0.001
93.40	Bottom of Swale	0.000	25.000	0.0	0.0	0.0	0.0	0.0	0.0	0.0	0.0	0.0	0.1	1.1	0.0000	0.10	1.52	0.07	0.00016		0.100	0.000	0.000
													0.0	1.0	0.0	0.00	1.82	0.0	0.00000		0.000	0.000	0.000

Orifice FLOW

$$Q_{ORIFICE} = C A (2 g H)^{0.5}$$

where:

C = Discharge Coefficient

$Q_{ORIFICE}$ = Orifice Flow (m³/s)

A = Orifice Area (m²)

g = Accel due to Gravity (9.81 m/s²)

H = Head above centre of orifice (m)

Figure 1: Discharge-Storage Curve

Client: CAMM Warehousing and Rentals Inc
Job No.: 230156
Location: 6622 Bank Street, Ottawa
Date: October 02, 2024

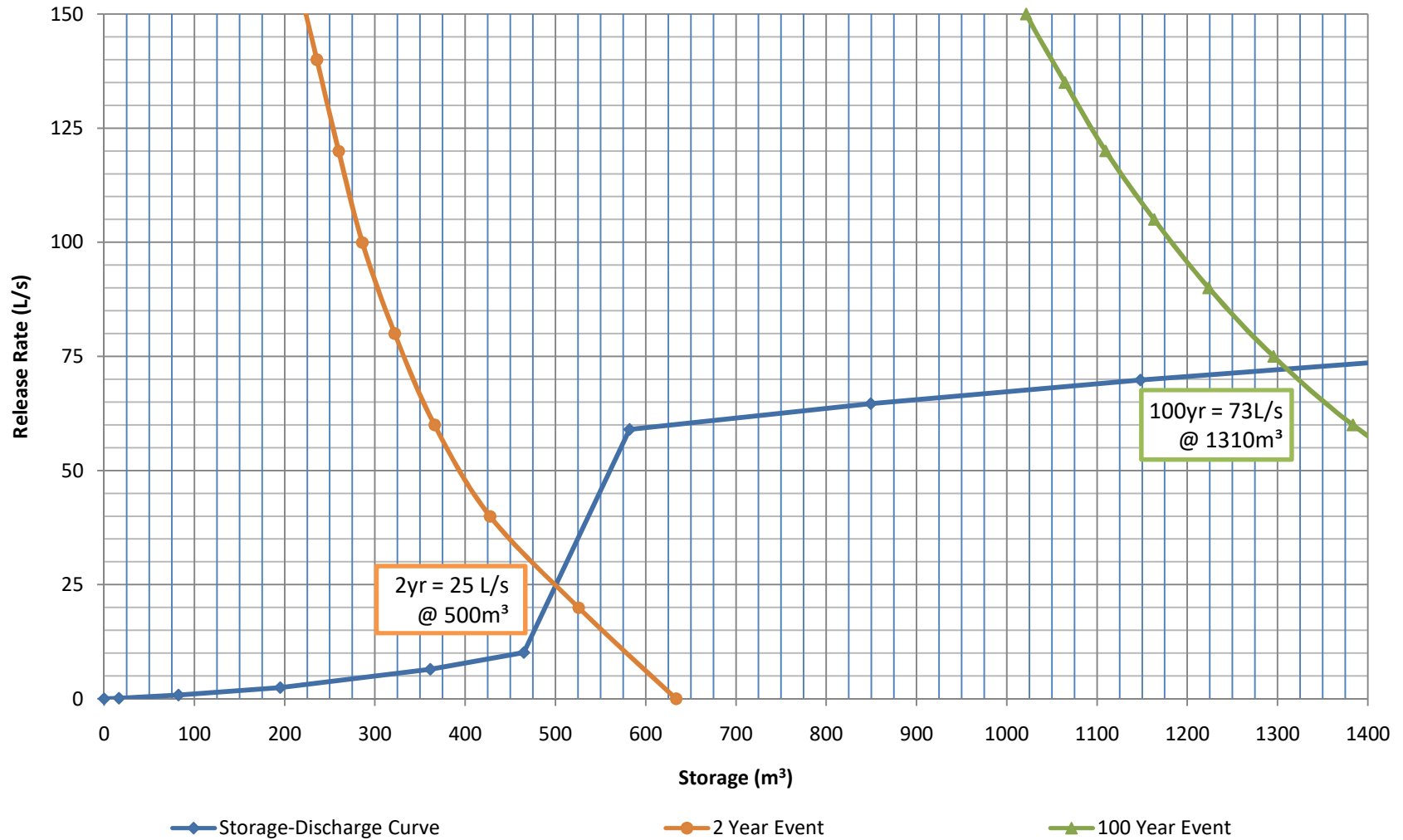
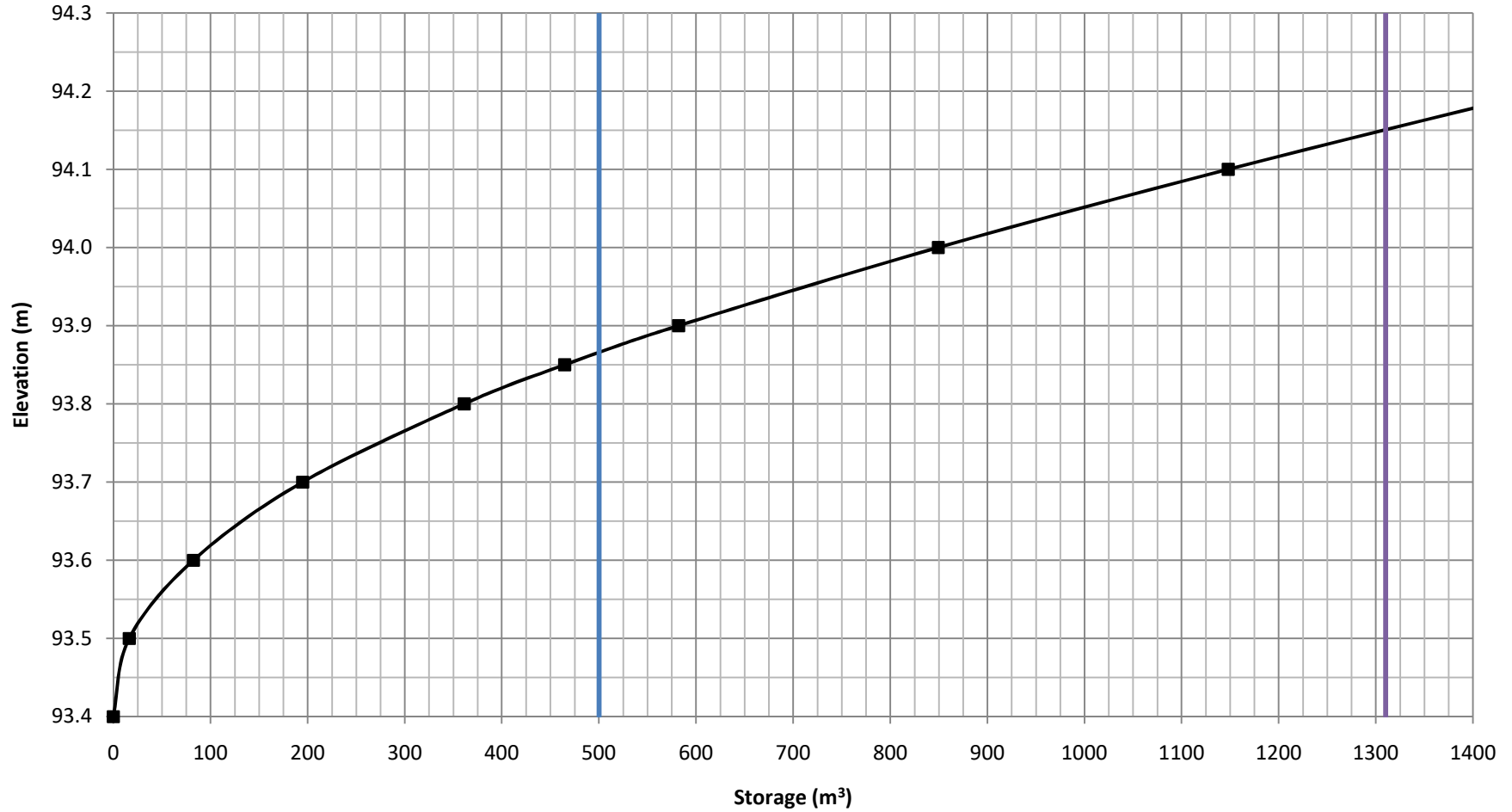

Figure 2: Stage-Storage Curve

Client: CAMM Warehousing and Rentals Inc
Job No.: 230156
Location: 6622 Bank Street, Ottawa
Date: October 02, 2024



■ Storage vs Elevation — 2 yr Storage Requirement — 100 yr storage requirement



Kollaard Associates

Engineers

Rev 2 – January 10, 2024

Stormwater Management Report

CAMM Warehousing and Rentals Inc.

6622 Bank St., Ottawa, ON

File No. 230156

Appendix B: Product Information

Terrafix 360R - Geotextile

Function: Filtration & Drainage.

Terrafix 360R is a needle-punched nonwoven geotextile made of 100% virgin polypropylene staple fibers, which are formed into a random network for dimensional stability. Terrafix 360R resists ultraviolet deterioration, rotting, biological degradation, naturally encountered alkalis and acids. Polypropylene is stable within the pH range of 2-13.

Types of applications for 360R are: Subdrains, French Drains, Foundation Drains, Trench Drains, Blanket Drains.

360R used in weaker soil conditions. Used in conjunction with coarser drainage materials.

Property	ASTM Test Method	Value Metric Units
Typical Geotextile Properties		
• Grab Tensile Strength	D 4632	712 N
• Elongation at break	D 4632	50-105%
• Tear Resistance	D 4533	267 N
• Puncture CBR	D 6241	1820 N
• Permittivity	D 4491	1.5 sec ⁻¹
• Water Flow	D 4491	4480 l/min/m ²
• Apparent Opening Size	D 4751	212 µm
• U.V. Stability	D 4355	70% @ 500hrs
• FOS	CAN 148.1 No.1	70-160 µm

The information contained herein has been compiled by TAG Ltd. and is, to the best of our knowledge, true and accurate. This information is offered without warranty. Final determination of suitability for use contemplated is the sole responsibility of the user. This information is subject to change without notice. Terrafix is a registered trademark of Terrafix Geosynthetics Inc.
Values entered are values obtained at the time of manufacturing. Handling and storage conditions may change some properties.

Terrafix 01-2021



Kollaard Associates

Engineers

Rev 2 – January 10, 2024

Stormwater Management Report

CAMM Warehousing and Rentals Inc.

6622 Bank St., Ottawa, ON

File No. 230156

Appendix C: Drawings

SITE STATISTICS:	
TOTAL AREA	60190 m ²
AREA OF NEW DEVELOPMENT	22423 m ²
EXISTING BUILDING FOOTPRINT	2517 m ²
NEW BUILDING FOOTPRINT	4348 m ²
GROSS FLOOR AREA (TOTAL)	
WAREHOUSE	4094 m ²
ACCESSORY OFFICE	174 m ²

PARKING REQUIREMENTS			
VEHICULAR PARKING	REQUIRED	PROVIDED	
WAREHOUSE (0.8 per 100m ² OF GFA)	33	35	
ACCESSORY OFFICE (2.4 per 100m ² OF GFA)	4	4	
TOTAL	37	39	
ACCESSIBLE PARKING TYPE A			
	1	1	
ACCESSIBLE PARKING TYPE B			
	1	1	
TOTAL	2	2	
LOADING SPACE			
	1	5	

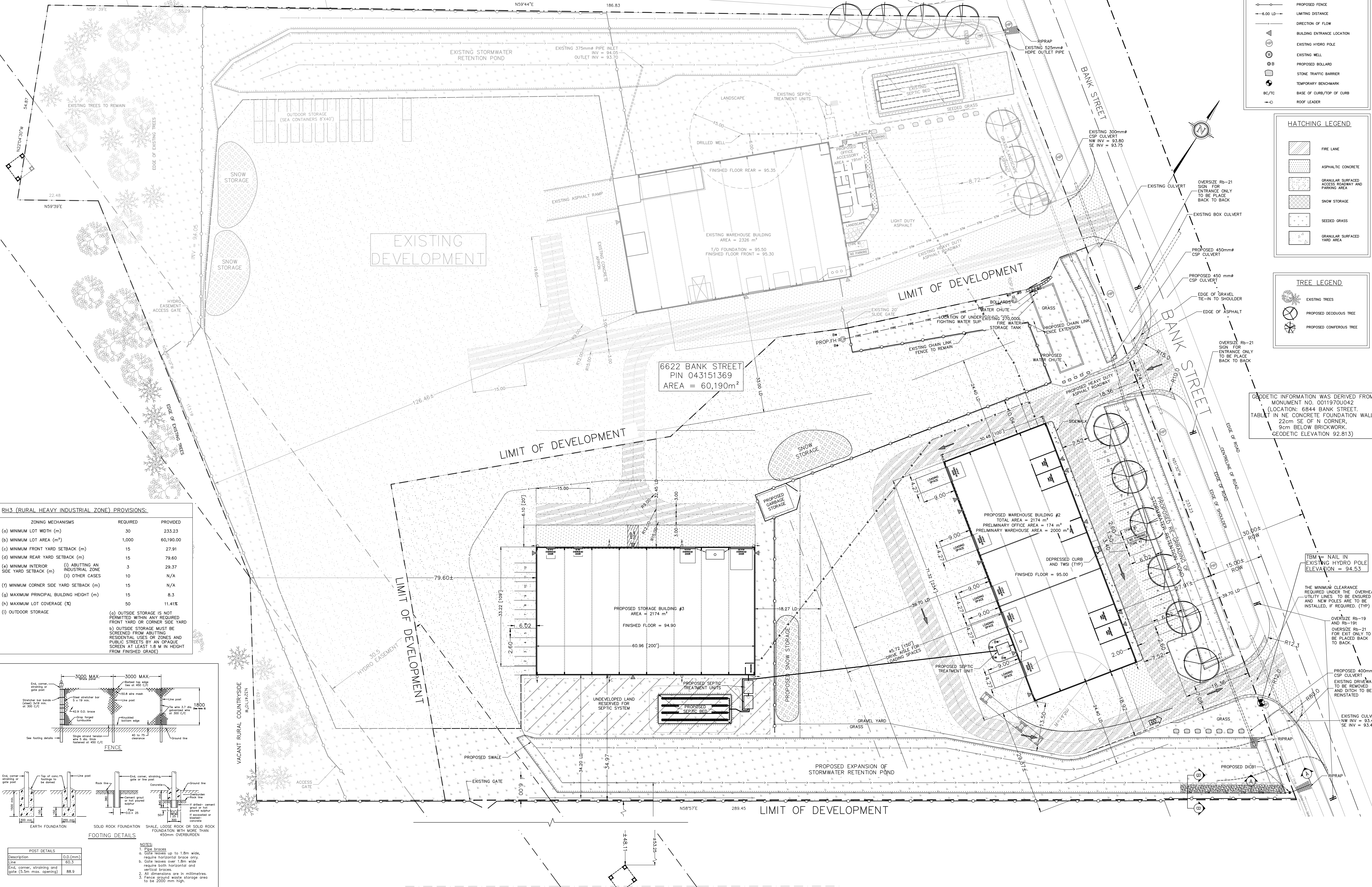

RH3 (RURAL HEAVY INDUSTRIAL ZONE) PROVISIONS:

ZONING MECHANISMS	REQUIRED	PROVIDED
(a) MINIMUM LOT WIDTH (m)	30	233.23
(b) MINIMUM LOT AREA (m ²)	1,000	60,190.00
(c) MINIMUM FRONT YARD SETBACK (m)	15	27.91
(d) MINIMUM REAR YARD SETBACK (m)	15	79.60
(e) MINIMUM INTERIOR SIDE YARD SETBACK (m)	3	29.37
(f) OTHER CASES		N/A
(g) MINIMUM CORNER SIDE YARD SETBACK (m)	15	N/A
(h) MAXIMUM PRINCIPAL BUILDING HEIGHT (m)	15	8.3
(i) MAXIMUM LOT COVERAGE (%)	50	11.41%

(c) OUTSIDE STORAGE IS NOT PERMITTED WITHIN ANY REQUIRED FRONT YARD OR CORNER SIDE YARD
 b) OUTSIDE STORAGE MUST BE SCREENED FROM ADJACENT RESIDENTIAL USES OR ZONES AND PUBLIC STREETS BY AN GRASS SCREEN AT LEAST 1.8 M IN HEIGHT FROM FINISHED GRADE)

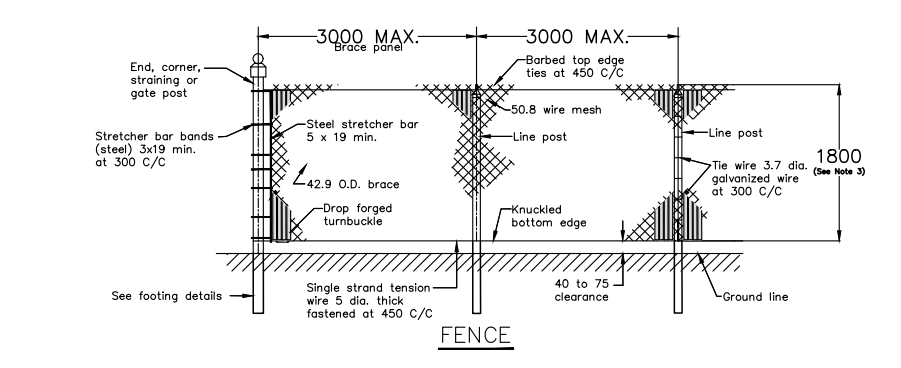

FOOTING DETAILS

POST DETAILS	DESCRIPTION	O.D. (mm)
1	Post brooks	60.3
2	End, corner, strapping and gate (5.0m max. opening)	86.9

NOTES:
 1. Post brooks
 2. Gate brooks up to 1.8m wide, require horizontal brace only.
 3. Gate brooks over 1.8m wide require both horizontal and vertical brooks.
 4. All dimensions are in millimetres.
 5. Fence around waste storage area to be 2000 mm high.

ELEVATION ~ CHAIN-LINK FENCE WITH PRIVACY SLATS (NOT TO SCALE)

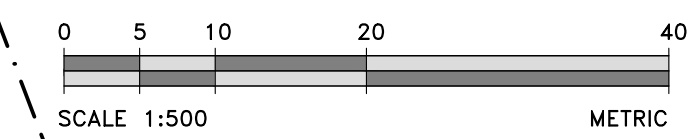

GENERAL LEGEND

- EXISTING ELEVATION
- PROPOSED/EXISTING ELEVATIONS
- DRAINAGE SLOPE
- CENTRELINE OF ROAD
- EDGE OF ROAD
- TOP OF SLOPE
- PROPERTY LINE
- OVERHEAD WIRE
- EDGE OF TREES
- PROPOSED FENCE
- LIMITING DISTANCE
- DIRECTION OF FLOW
- BUILDING ENTRANCE LOCATION
- EXISTING HYDRO POLE
- EXISTING WELL
- PROPOSED BOLLARD
- STONE TRAFFIC BARRIER
- TEMPORARY BENCHMARK
- BASE OF CURB/TOP OF CURB
- ROOF LEADER

HATCHING LEGEND

- FIRE LANE
- ASPHALTIC CONCRETE
- GRANULAR SURFACED ACCESS ROADWAY AND PARKING AREA
- SNOW STORAGE
- SEEDED GRASS
- GRANULAR SURFACED YARD AREA

TREE LEGEND

- EXISTING TREES
- PROPOSED DECIDUOUS TREE
- PROPOSED CONIFEROUS TREE

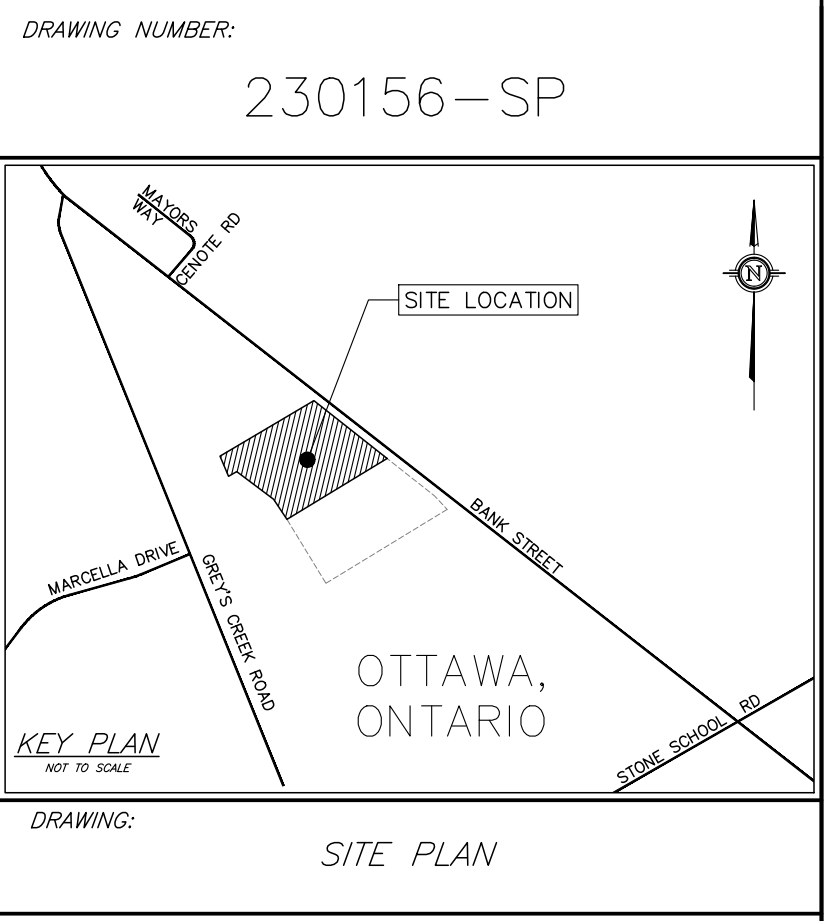

- GENERAL NOTES:**
- ALL DIMENSIONS ARE IN METRES, UNLESS OTHERWISE SPECIFIED. ALL ELEVATIONS ARE IN METRES AND ARE GEODETIC.
 - GEODETIC INFORMATION WAS DERIVED FROM MONUMENT NO. 0011970U042.
 - TBM = NAIL IN EXISTING HYDRO POLE. ELEVATION = 94.53.
 - THIS IS NOT A LEGAL SURVEY. BOUNDARY INFORMATION WAS DERIVED FROM PLAN 4R-25595. (SHIPMAN SURVEYING FILE NUMBER: 10-7-9718; HORIZONTAL DATUM: MTM ZONE 9, NAD 83)
 - CLIENT IS RESPONSIBLE FOR ACQUIRING ALL NECESSARY PERMITS.
 - CONTRACTOR TO VERIFY THAT APPROPRIATE PERMITS HAVE BEEN ACQUIRED PRIOR TO ANY CONSTRUCTION.
 - CONTRACTOR IS RESPONSIBLE FOR LOCATION AND PROTECTION OF UTILITIES.
 - ALL DIMENSIONS TO BE VERIFIED ON SITE BY CONTRACTOR PRIOR TO CONSTRUCTION.
 - THIS DRAWING IS NOT FOR CONSTRUCTION UNTIL ALL APPROVALS HAVE BEEN GRANTED.
 - HYDRO SERVICE TO BE INSTALLED ACCORDING TO THE SPECIFICATIONS OF SERVICE PROVIDER AND THE MECHANICAL ENGINEER.
 - ALL MATERIALS AND CONSTRUCTION TO BE IN ACCORDANCE WITH CITY OF OTTAWA STANDARDS AND ONTARIO PROVINCIAL STANDARDS AND SPECIFICATIONS.
 - ANY CHANGES MADE TO THIS PLAN MUST BE VERIFIED AND APPROVED BY KOLLAARD ASSOCIATES, INC.
 - THIS DRAWING IS PART OF KOLLAARD ASSOCIATES DESIGN REPORTS #230156.

REV	BY	DATE	DESCRIPTION
3	ARK	JAN 10, 2024	REVISED FOR CITY COMMENTS
2	ARK	OCT 02, 2024	REVISED AS PER CITY MEMO
1	ARK	SEPT 04, 2024	REVISED AS PER PLANNER
0	ARK	JULY 31, 2024	SUBMITTED FOR SITE PLAN CONTROL

Kollaard Associates Engineers

P.O. BOX 189, 210 PRESCOTT ST. (613) 860-0923
 KEMPVILLE, ONTARIO info@kollaard.ca
 KOG 1 JO FAX (613) 258-0475
 http://www.kollaard.ca

CONSULTANTS:

H.A.KEN SHIPMAN SURVEYING LTD.
 P.O. BOX 53, NORTH GOWER, ONT. M5A 2T0

JAMES B. LENNOX & ASSOCIATES INC.
 LANDSCAPE ARCHITECTS
 1100 HWY 725/348

Castleglen Consultants
 Engineers, Project Managers & Planners
 2460 Lancaster Road, Ottawa, ON K1B 4S5
 (613) 837-4922 / (613) 832-1033

CLIENT:
Camm Warehousing and Rentals Inc.

PROJECT:
PROPOSED WAREHOUSE WITH OFFICE

LOCATION:
6622 BANK STREET, OTTAWA, ON

DESIGNED BY: ARK
CHECKED BY: SD

DRAWN BY: ARK
APPROVED BY: SD

DATE: JULY 31, 2024

SCALE: AS NOTED

PROJECT NUMBER: 230156

PROFESSIONAL ENGINEER
 S. E. deWit
 100079612
 PROVINCE OF ONTARIO

SITE PLAN
SCALE = 1:500

© COPYRIGHT 2024
KOLLAARD ASSOCIATES INCORPORATED

D07-12-24-0106

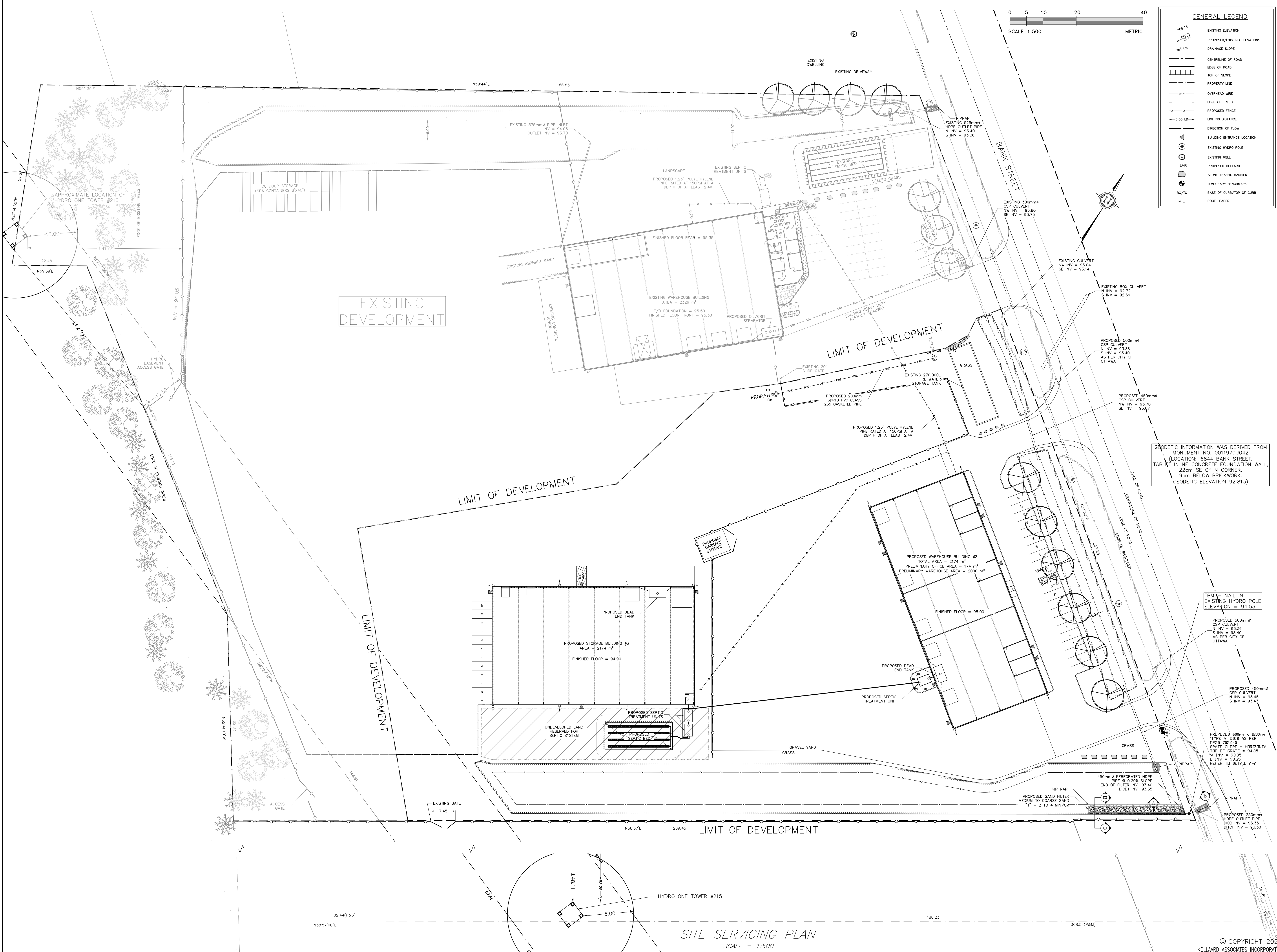

0 5 10 20 40
SCALE 1:500 METRIC

GENERAL LEGEND

	EXISTING ELEVATION
	PROPOSED/EXISTING ELEVATIONS
	DRAINAGE SLOPE
	CENTRELINE OF ROAD
	EDGE OF ROAD
	TOP OF SLOPE
	PROPERTY LINE
	OVERHEAD WIRE
	EDGE OF TREES
	PROPOSED FENCE
	LIMITING DISTANCE
	DIRECTION OF FLOW
	BUILDING ENTRANCE LOCATION
	EXISTING HYDRO POLE
	EXISTING WELL
	PROPOSED WELL
	STONE TRAFFIC BARRIER
	TEMPORARY BENCHMARK
	BASE OF CURB/TOP OF CURB
	ROOF LEADER

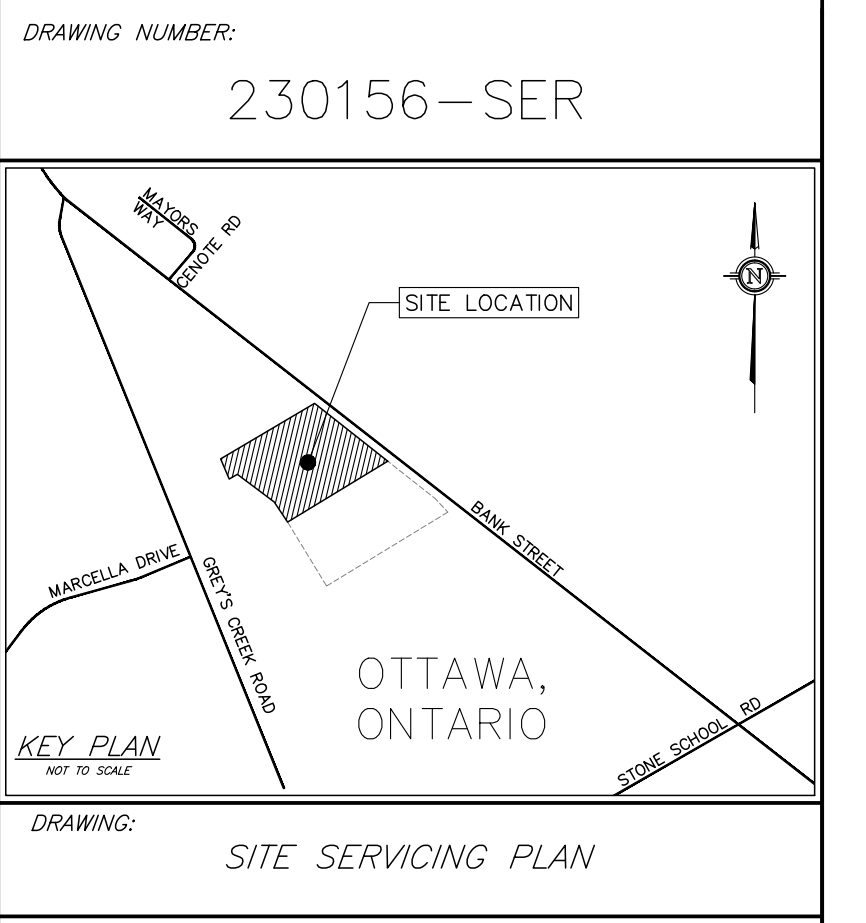

- GENERAL NOTES:
- ALL DIMENSIONS ARE IN METRES, UNLESS OTHERWISE SPECIFIED. ALL ELEVATIONS ARE IN METRES AND ARE GEODETIC.
 - GEODETIC INFORMATION WAS DERIVED FROM MONUMENT NO. 0011970042.
 - TBM = NAIL IN EXISTING HYDRO POLE. ELEVATION = 94.53.
 - THIS IS NOT A LEGAL SURVEY. BOUNDARY INFORMATION WAS DERIVED FROM PLAN 4R-25595. (SHIPMAN SURVEYING FILE NUMBER: 10-7-9718; HORIZONTAL DATUM: MTM ZONE 9, NAD 83)
 - CLIENT IS RESPONSIBLE FOR ACQUIRING ALL NECESSARY PERMITS.
 - CONTRACTOR TO VERIFY THAT APPROPRIATE PERMITS HAVE BEEN ACQUIRED PRIOR TO ANY CONSTRUCTION.
 - CONTRACTOR IS RESPONSIBLE FOR LOCATION AND PROTECTION OF UTILITIES.
 - ALL DIMENSIONS TO BE VERIFIED ON SITE BY CONTRACTOR PRIOR TO CONSTRUCTION.
 - THIS DRAWING IS NOT FOR CONSTRUCTION UNLESS ALL APPROVALS HAVE BEEN GRANTED.
 - HYDRO SERVICE TO BE INSTALLED ACCORDING TO THE SPECIFICATIONS OF SERVICE PROVIDER AND THE MECHANICAL ENGINEER.
 - ALL MATERIALS AND CONSTRUCTION TO BE IN ACCORDANCE WITH CITY OF OTTAWA STANDARDS AND ONTARIO PROVINCIAL STANDARDS AND SPECIFICATIONS.
 - ANY CHANGES MADE TO THIS PLAN MUST BE VERIFIED AND APPROVED BY KOLLAARD ASSOCIATES, INC.
 - THIS DRAWING IS PART OF KOLLAARD ASSOCIATES DESIGN REPORTS #230156.

GEODETIC INFORMATION WAS DERIVED FROM MONUMENT NO. 0011970042 (LOCATION: 6844 BANK STREET, 22cm SE OF N CORNER, 9cm BELOW BRICKWORK, GEODETIC ELEVATION 92.813)

REV	BY	DATE	DESCRIPTION
3	ARK	JAN 10, 2024	REVISED FOR CITY COMMENTS
2	ARK	OCT 02, 2024	NO CHANGES TO THIS SHEET
1	ARK	SEPT 04, 2024	NO CHANGES TO THIS SHEET
0	ARK	JULY 31, 2024	SUBMITTED FOR SITE PLAN CONTROL

Kollaard Associates
Engineers

P.O. BOX 189, 210 PRESCOTT ST. (613) 860-0923
KEMPVILLE, ONTARIO info@kollaard.ca
KOG 1J0 FAX (613) 258-0475
http://www.kollaard.ca

CONSULTANTS:

H.A.KEN SHIPMAN SURVEYING LTD. P.O. BOX 53, NORTH GOWER, ONT. N0A 2T0
JAMES B. LENNOX & ASSOCIATES INC. LANDSCAPE ARCHITECTS
P.O. BOX 53, NORTH GOWER, ONT. N0A 2T0

Castleglen Consultants
Engineers, Project Managers & Planners
2460 Lancaster Road, Ottawa, ON K1B 4S5
(613) 721-7225

CLIENT:
CAMM WAREHOUSING AND RENTALS INC.

PROJECT:
PROPOSED WAREHOUSE WITH OFFICE

LOCATION:
6622 BANK STREET, OTTAWA, ON

DESIGNED BY: ARK
DRAWN BY: ARK
DATE: JULY 31, 2024
SCALE: AS NOTED
PROJECT NUMBER: 230156

CHECKED BY: SD
APPROVED BY: SD

LICENSED PROFESSIONAL ENGINEER
JAN 10, 2024
S. E. deWit
100079612
PROVINCE OF ONTARIO

© COPYRIGHT 2024
KOLLAARD ASSOCIATES INCORPORATED

SITE SERVICING PLAN
SCALE = 1:500

D07-12-24-0106

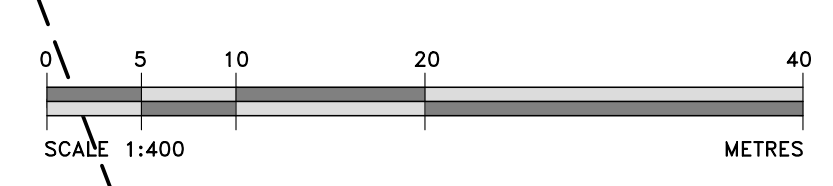
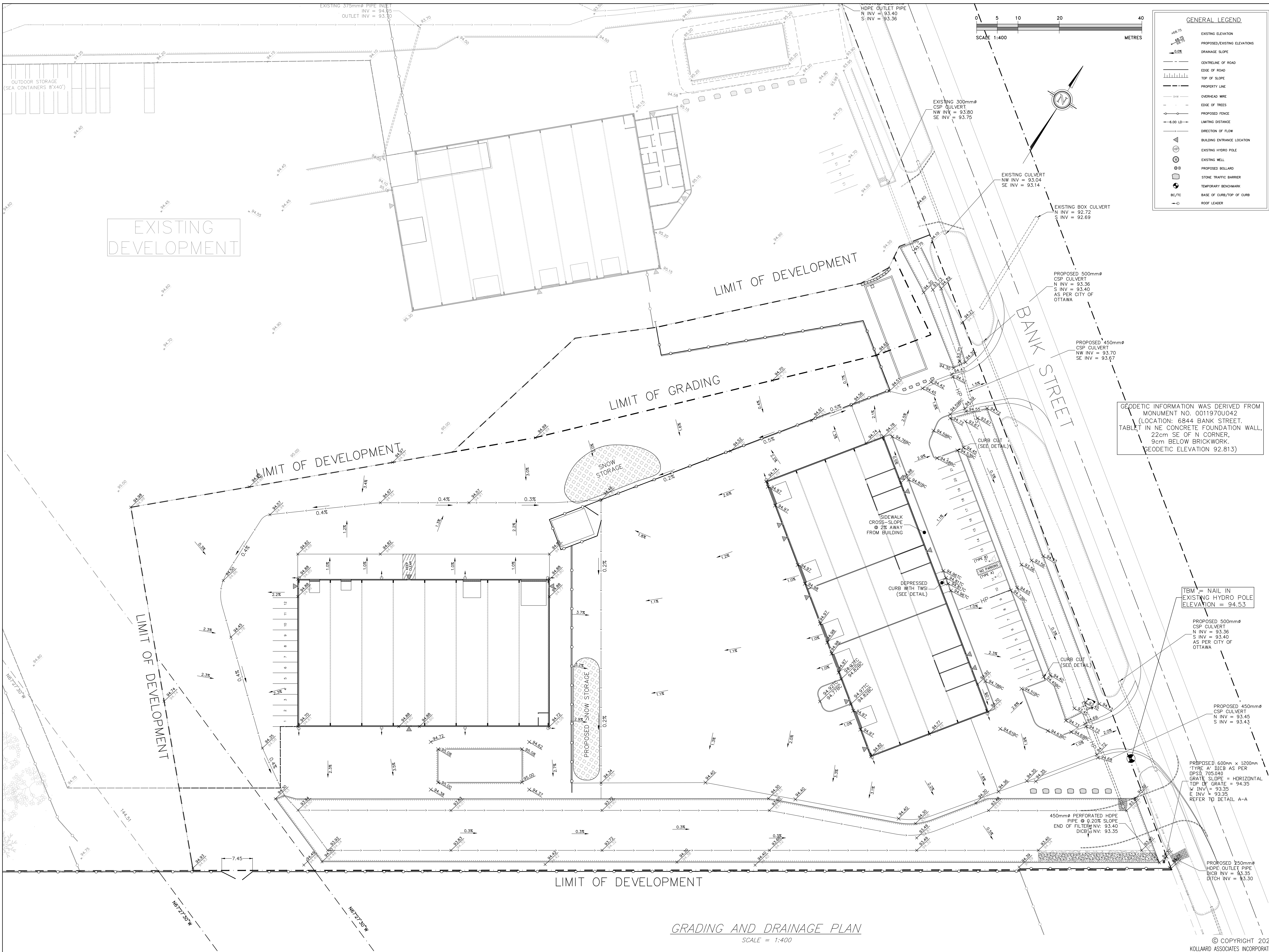

GENERAL LEGEND

- EXISTING ELEVATION
- PROPOSED/EXISTING ELEVATIONS
- DRAINAGE SLOPE
- CENTRELINE OF ROAD
- EDGE OF ROAD
- TOP OF SLOPE
- PROPERTY LINE
- OVERHEAD WIRE
- EDGE OF TREES
- PROPOSED FENCE
- LIMITING DISTANCE
- DIRECTION OF FLOW
- BUILDING ENTRANCE LOCATION
- EXISTING HYDRO POLE
- EXISTING WELL
- PROPOSED BOLLARD
- STONE TRAFFIC BARRIER
- TEMPORARY BENCHMARK
- BASE OF CURB/TOP OF CURB
- ROOF LEADER

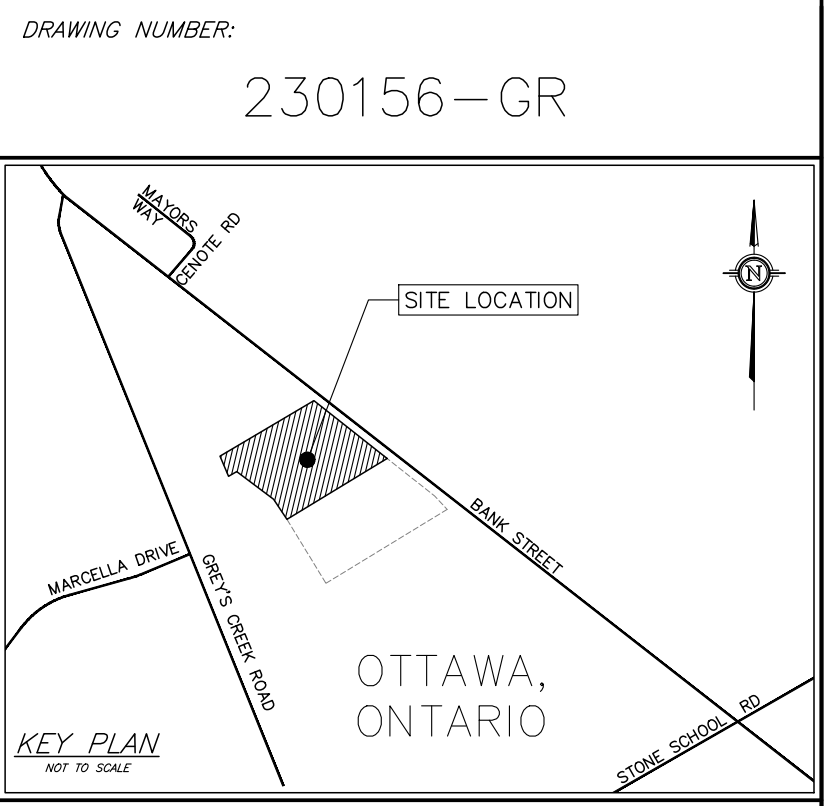

DRAWING: GRADING AND DRAINAGE PLAN

- GENERAL NOTES:**
- ALL DIMENSIONS ARE IN METRES, UNLESS OTHERWISE SPECIFIED. ALL ELEVATIONS ARE IN METRES AND ARE GEODETIC.
 - GEODETIC INFORMATION WAS DERIVED FROM MONUMENT NO. 0011970U042.
 - TBM = NAIL IN EXISTING HYDRO POLE. ELEVATION = 94.53.
 - THIS IS NOT A LEGAL SURVEY. BOUNDARY INFORMATION WAS DERIVED FROM PLAN 4R-25595. (SHIPMAN SURVEYING FILE NUMBER: 10-7-9718; HORIZONTAL DATUM: MTM ZONE 9, NAD 83)
 - CLIENT IS RESPONSIBLE FOR ACQUIRING ALL NECESSARY PERMITS.
 - CONTRACTOR TO VERIFY THAT APPROPRIATE PERMITS HAVE BEEN ACQUIRED PRIOR TO ANY CONSTRUCTION.
 - CONTRACTOR IS RESPONSIBLE FOR LOCATION AND PROTECTION OF UTILITIES.
 - ALL DIMENSIONS TO BE VERIFIED ON SITE BY CONTRACTOR PRIOR TO CONSTRUCTION.
 - THIS DRAWING IS NOT FOR CONSTRUCTION UNTIL ALL APPROVALS HAVE BEEN GRANTED.
 - HYDRO SERVICE TO BE INSTALLED ACCORDING TO THE SPECIFICATIONS OF SERVICE PROVIDER AND THE MECHANICAL ENGINEER.
 - ALL MATERIALS AND CONSTRUCTION TO BE IN ACCORDANCE WITH CITY OF OTTAWA STANDARDS AND ONTARIO PROVINCIAL STANDARDS AND SPECIFICATIONS.
 - ANY CHANGES MADE TO THIS PLAN MUST BE VERIFIED AND APPROVED BY KOLLAARD ASSOCIATES, INC.
 - THIS DRAWING IS PART OF KOLLAARD ASSOCIATES DESIGN REPORTS #230156.

GEODETIC INFORMATION WAS DERIVED FROM MONUMENT NO. 0011970U042 (LOCATION: 6844 BANK STREET, TABLET IN NE CONCRETE FOUNDATION WALL, 22cm SE OF N CORNER, 9cm BELOW BRICKWORK. GEODETIC ELEVATION 92.813)

REV	BY	DATE	DESCRIPTION
3	ARK	JAN 10, 2024	REVISED FOR CITY COMMENTS
2	ARK	OCT 02, 2024	NO CHANGES TO THIS SHEET
1	ARK	SEPT 04, 2024	NO CHANGES TO THIS SHEET
0	ARK	JULY 31, 2024	ISSUED FOR SITE PLAN CONTROL

Kollaard Associates Engineers

P.O. BOX 189, 210 PRESCOTT ST. (613) 860-0923
 KEMPVILLE, ONTARIO info@kollaard.ca
 KOG 1JO FAX (613) 258-0475
 http://www.kollaard.ca

CONSULTANTS:

H.A.KEN SHIPMAN SURVEYING LTD. LANDSCAPE ARCHITECTS
 P.O. BOX 53 NORTH GOWER, ONT. K8A 2T0
 TEL: (613) 723-3348

Castleglen Consultants
 Engineers, Project Managers & Planners
 2460 Lancaster Road, Ottawa, ON K1B 4S5
 TEL: (613) 761-4927 / (613) 761-4923

CLIENT:
Camm Warehousing and Rentals Inc.

PROJECT:
PROPOSED WAREHOUSE WITH OFFICE

LOCATION:
6622 BANK STREET, OTTAWA, ON

DESIGNED BY: ARK	CHECKED BY: SD
DRAWN BY: ARK	APPROVED BY: SD
DATE: JULY 31, 2024	
SCALE: AS NOTED	
PROJECT NUMBER: 230156	



GRADING AND DRAINAGE PLAN
SCALE = 1:400

© COPYRIGHT 2024
KOLLAARD ASSOCIATES INCORPORATED

D07-12-24-0106

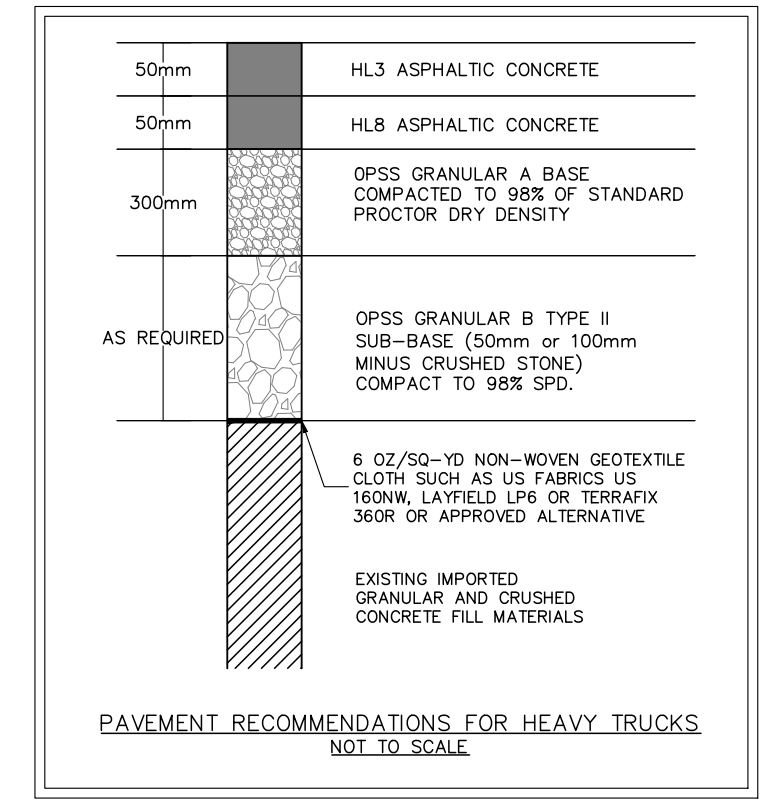
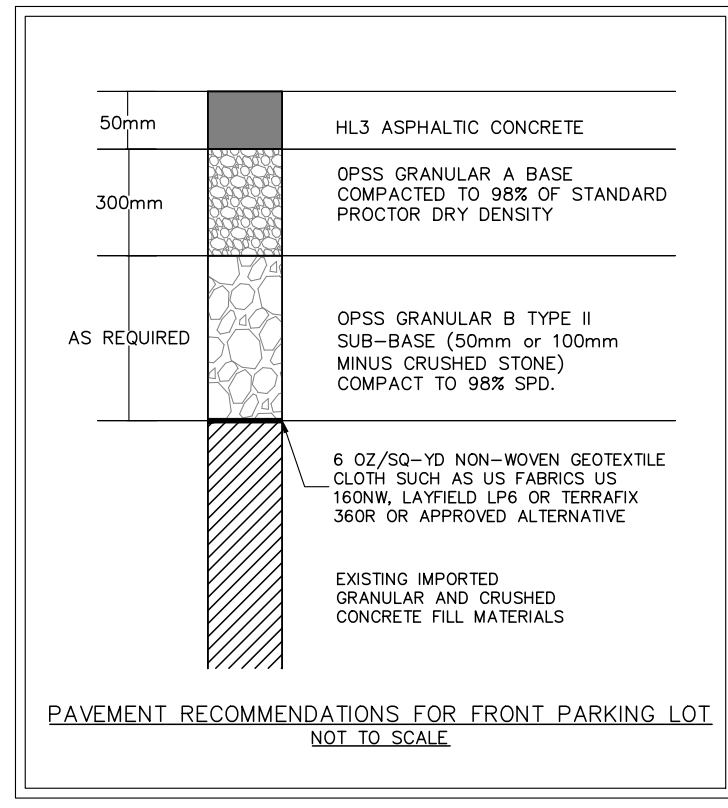
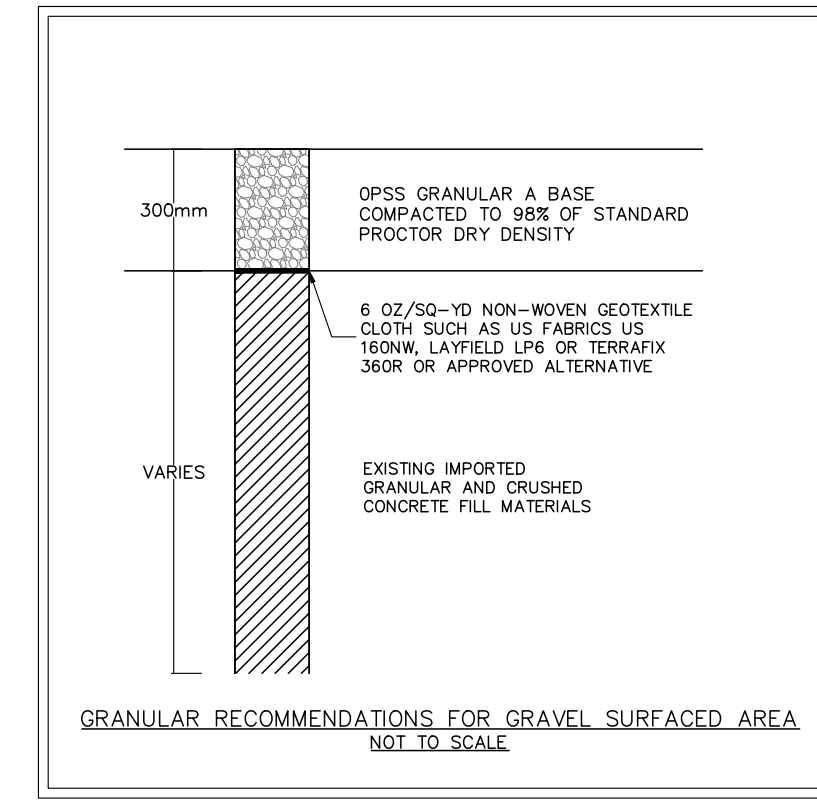
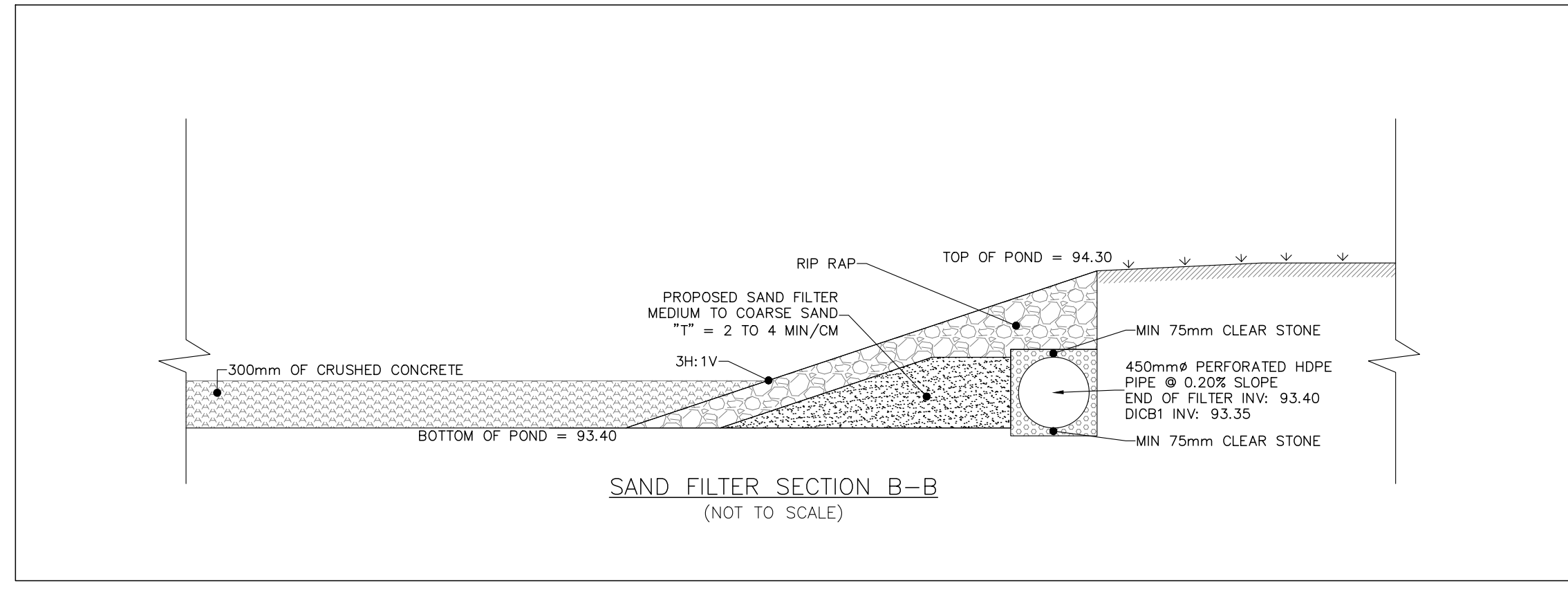
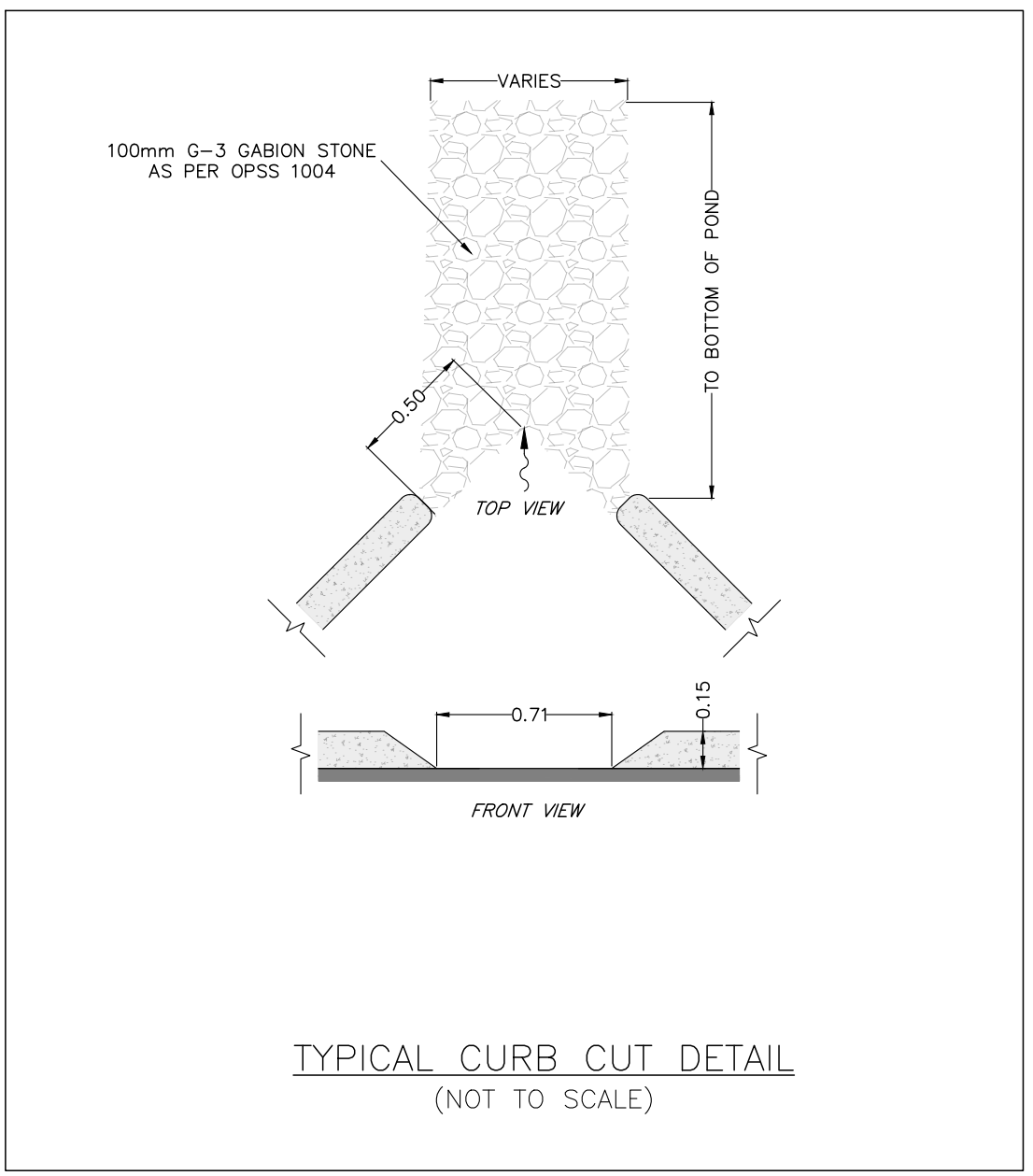
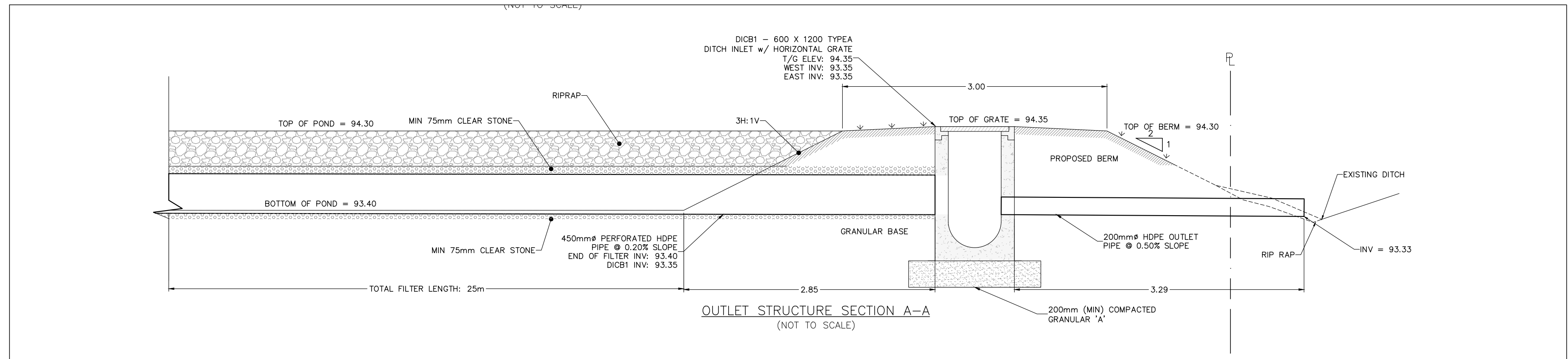

DRAWING NUMBER: 230156-DET

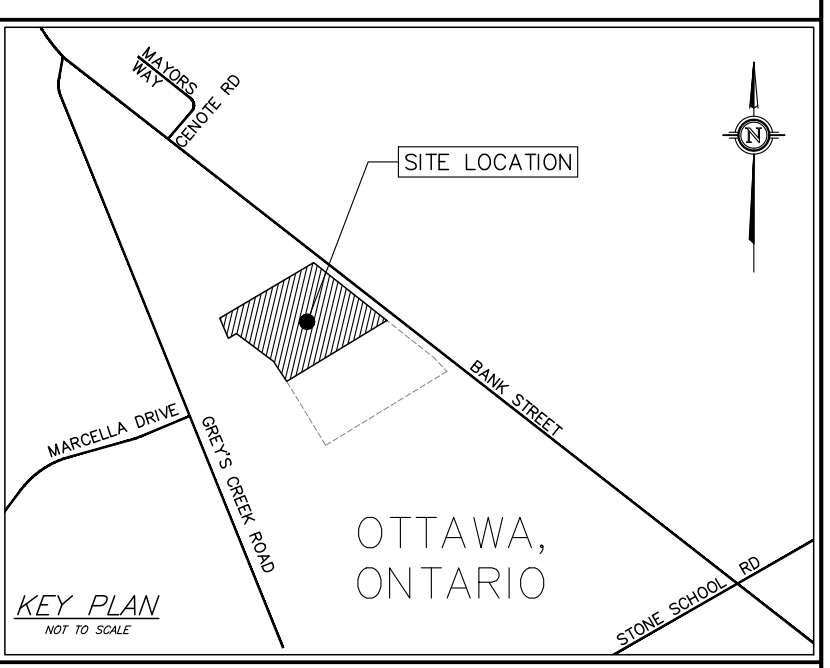

DRAWING: DETAILS

- GENERAL NOTES:
1. ALL DIMENSIONS ARE IN METRES, UNLESS OTHERWISE SPECIFIED. ALL ELEVATIONS ARE IN METRES AND ARE GEODETIC.
 2. GEODETIC INFORMATION WAS DERIVED FROM MONUMENT NO. 0011970U042.
 3. TBM = NAIL IN EXISTING HYDRO POLE. ELEVATION = 94.53.
 4. THIS IS NOT A LEGAL SURVEY. BOUNDARY INFORMATION WAS DERIVED FROM PLAN 4R-25595. (SHIPMAN SURVEYING FILE NUMBER: 10-7-9718; HORIZONTAL DATUM: MTM ZONE 9, NAD 83)
 5. CLIENT IS RESPONSIBLE FOR ACQUIRING ALL NECESSARY PERMITS.
 6. CONTRACTOR TO VERIFY THAT APPROPRIATE PERMITS HAVE BEEN ACQUIRED PRIOR TO ANY CONSTRUCTION.
 7. CONTRACTOR IS RESPONSIBLE FOR LOCATION AND PROTECTION OF UTILITIES.
 8. ALL DIMENSIONS TO BE VERIFIED ON SITE BY CONTRACTOR PRIOR TO CONSTRUCTION.
 9. THIS DRAWING IS NOT FOR CONSTRUCTION UNTIL ALL APPROVALS HAVE BEEN GRANTED.
 10. HYDRO SERVICE TO BE INSTALLED ACCORDING TO THE SPECIFICATIONS OF SERVICE PROVIDER AND THE MECHANICAL ENGINEER.
 11. ALL MATERIALS AND CONSTRUCTION TO BE IN ACCORDANCE WITH CITY OF OTTAWA STANDARDS AND ONTARIO PROVINCIAL STANDARDS AND SPECIFICATIONS.
 12. ANY CHANGES MADE TO THIS PLAN MUST BE VERIFIED AND APPROVED BY KOLLAARD ASSOCIATES, INC.
 13. THIS DRAWING IS PART OF KOLLAARD ASSOCIATES DESIGN REPORTS #230156.

REV	BY	DATE	DESCRIPTION
3	ARK	JAN 10, 2024	REVISED FOR CITY COMMENTS
2	ARK	OCT 02, 2024	NO CHANGES TO THIS SHEET
1	ARK	SEPT 04, 2024	NO CHANGES TO THIS SHEET
0	ARK	JULY 31, 2024	SUBMITTED FOR SITE PLAN CONTROL

Kollaard Associates Engineers
P.O. BOX 189, 210 PRESCOTT ST. (613) 860-0923
KEMPVILLE, ONTARIO info@kollaard.ca
KOG 1J0 FAX (613) 258-0475
http://www.kollaard.ca

CONSULTANTS:

H.A.KEN SHIPMAN SURVEYING LTD.
P.O. BOX 53 NORTH GOMER, ONT. K5A 2T0

JAMES B. LENNOX & ASSOCIATES INC.
LANDSCAPE ARCHITECTS
1000 UNIVERSITY AVENUE
OTTAWA, ONTARIO K1N 6N5
TEL: (613) 725-5888 FAX: (613) 725-5888

IFR Business Consulting
URBAN PLANNING CONSULTING PROJECT MANAGEMENT
188 Somerset Drive, Ottawa, Ontario K1R 1H5
(613) 725-5888 info@ifrconsulting.com

Castleglen Consultants
Engineers, Project Managers & Planners
2460 Lancaster Road, Ottawa, ON K1B 4S5
(613) 725-4922 / (613) 725-4923

CLIENT:
Camm Warehousing and Rentals Inc.

PROJECT:
PROPOSED WAREHOUSE WITH OFFICE

LOCATION:
6622 BANK STREET, OTTAWA, ON

DESIGNED BY: ARK CHECKED BY: SD
DRAWN BY: ARK APPROVED BY: SD
DATE: JULY 31, 2024
SCALE: DETAILS
PROJECT NUMBER: 230156-DET



© COPYRIGHT 2024
KOLLAARD ASSOCIATES INCORPORATED

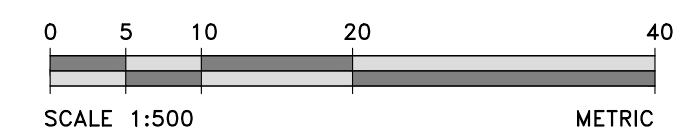

DRAWING NUMBER:
230156-ESC

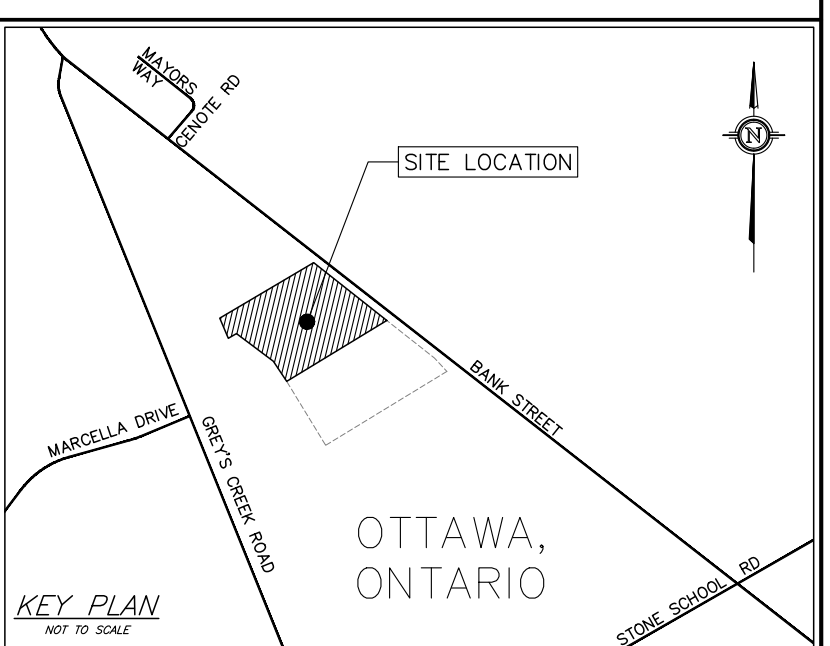

DRAWING:
EROSION AND SEDIMENT CONTROL PLAN

EROSION AND SEDIMENT CONTROL NOTES:

1. THE CONTRACTOR SHALL IMPLEMENT BEST MANAGEMENT PRACTICES, TO PROVIDE FOR PROTECTION OF THE AREA DRAINAGE SYSTEM AND THE RECEIVING WATERCOURSE, DURING CONSTRUCTION ACTIVITIES. THE CONTRACTOR ACKNOWLEDGES THAT FAILURE TO IMPLEMENT APPROPRIATE EROSION AND SEDIMENT CONTROL MEASURES MAY BE SUBJECT TO PENALTIES IMPOSED BY ANY APPLICABLE REGULATORY AGENCY.
2. THE CONTRACTOR AGREES TO PREPARE AND IMPLEMENT AN EROSION AND SEDIMENT CONTROL PLAN AT LEAST EQUAL TO THE STATED MINIMUM REQUIREMENTS AND TO THE SATISFACTION OF THE CITY OF OTTAWA, APPROPRIATE TO THE SITE CONDITIONS, PRIOR TO UNDERTAKING ANY SITE ALTERATIONS (FILLING, GRADING, REMOVAL OF VEGETATION, ETC.) AND DURING ALL PHASES OF SITE PREPARATION AND CONSTRUCTION IN ACCORDANCE WITH THE CURRENT BEST MANAGEMENT PRACTICES FOR EROSION AND SEDIMENT CONTROL.
3. ALL EROSION CONTROL MEASURES ARE TO BE IN PLACE PRIOR TO STARTING CONSTRUCTION AND REMAIN IN PLACE UNTIL SITE WORKS ARE COMPLETE.
4. THE CONTRACTOR IS RESPONSIBLE FOR INSPECTION AND MAINTENANCE OF THE EROSION CONTROL MEASURES DURING CONSTRUCTION. INSPECTION IS TO BE CARRIED OUT ON A WEEKLY BASIS AND AFTER SIGNIFICANT RAINFALL OR SNOWMELT EVENT. THE CONTRACTOR IS RESPONSIBLE FOR REMOVAL OF THE MEASURES ONCE DEVELOPMENT IS COMPLETE AND THE VEGETATION IS ESTABLISHED.
5. THE CONTRACTOR IS TO ENSURE THAT THE SITE ACCESS POINTS AND STREETS ADJACENT TO THE ACCESS POINTS ARE MAINTAINED AND KEPT CLEAN OF CONSTRUCTION MATERIALS SUCH AS, BUT NOT LIMITED TO MUD, DIRT, CLAY AND GRANULARS ON A DAILY BASIS OR AS NECESSARY, TO THE SATISFACTION OF THE CITY OF OTTAWA. A MUD MAT IS TO BE UTILIZED AT ANY LOCATION WHERE THE SITE IS ACCESSED FOR CONSTRUCTION.
6. EVERY EFFORT WILL BE MADE TO ENSURE THAT ALL DISTURBED AREAS ARE TOPSOILED AND SEEDED AS SOON AS REASONABLY POSSIBLE.
7. THE SEDIMENT AND EROSION CONTROL PLAN IS A LIVING DOCUMENT WHICH MAY BE AMENDED BY ONSITE REQUIREMENTS AT THE APPROVAL OF THE MUNICIPALITY AND THE CONSERVATION AUTHORITY.

GEODEIC INFORMATION WAS DERIVED FROM MONUMENT NO. 0011970042 (LOCATION: 6844 BANK STREET, 22cm SE OF N CORNER, 9cm BELOW BRICKWORK, GEODEIC ELEVATION 92.613)

TBM = NAIL IN EXISTING HYDRO POLE ELEVATION = 94.53

REV	BY	DATE	DESCRIPTION
3	ARK	JAN 10, 2024	REVISED FOR CITY COMMENTS
2	ARK	OCT 02, 2024	REVISED AS PER CITY MEMO
1	ARK	SEPT 04, 2024	NO CHANGES TO THIS SHEET
0	ARK	JULY 31, 2024	SUBMITTED FOR SITE PLAN CONTROL

K Kollaard Associates
Engineers

P.O. BOX 189, 210 PRESCOTT ST. (613) 860-0923
KEMPVILLE, ONTARIO info@kollaard.ca
KOG 1J0 FAX (613) 258-0475
http://www.kollaard.ca

CONSULTANTS:
H.A.KEN SHIPMAN SURVEYING LTD. LANDSCAPE ARCHITECTS
JAMES B. LENNOX & ASSOCIATES INC. ARCHITECTS

URBAN PLANNING CONSULTANTS Castleglenn Consultants
Engineers, Project Managers & Planners

CLIENT:
Camm Warehousing and Rentals Inc.

PROJECT:
PROPOSED WAREHOUSE WITH OFFICE

LOCATION:
6622 BANK STREET, OTTAWA, ON

DESIGNED BY: ARK	CHECKED BY: SD
DRAWN BY: ARK	APPROVED BY: SD
DATE: JULY 31, 2024	SCALE: AS NOTED
PROJECT NUMBER: 230156	

DESIGNED BY: S. E. deWit
100079612
PROVINCE OF ONTARIO

© COPYRIGHT 2024
KOLLAARD ASSOCIATES INCORPORATED

LEGEND (SWM/ESC)

CONTROLLED	CATCHMENT LABEL
0.39	CATCHMENT AREA (HECTARES)
0.34	IMPERVIOUS RATIO
---	CATCHMENT AREA BOUNDARY
→	DIRECTION OF FLOW
- - - -	PROPERTY LINE
---	TOP OF SLOPE
~~~~~	PROPOSED SILT FENCE
▨	CONTROLLED AREA
▩	UNCONTROLLED AREA
~~~~~	PRE-DEVELOPMENT DRAINAGE PATTERN
→	POST-DEVELOPMENT DRAINAGE PATTERN

- MINIMUM EROSION AND SEDIMENT CONTROL PLAN REQUIREMENTS:**
- TIME THE DEMOLITION AND EXCAVATION ACTIVITIES SO THAT THEY OCCUR NO SOONER THAN IS NECESSARY FOR SUBSEQUENT CONSTRUCTION ACTIVITIES.
 - LANDSCAPE THE SITE AS SOON AS PRACTICALLY POSSIBLE.
 - USE SILT FENCES AROUND ANY STOCKPILES OF SOIL.
 - PRIOR TO CONSTRUCTION, SILT FENCE BARRIERS (OPSD 219.110) WILL BE PLACED AS SHOWN ON THE DRAWING.
 - IF CONSTRUCTION IS PHASED, SILT FENCES TO BE PLACED AROUND ACTIVE CONSTRUCTION ZONES.
 - THE SILT FENCE SHOULD BE REMOVED ONLY WHEN THE SITE IS STABILIZED.

EROSION AND SEDIMENT CONTROL PLAN
SCALE = 1:500

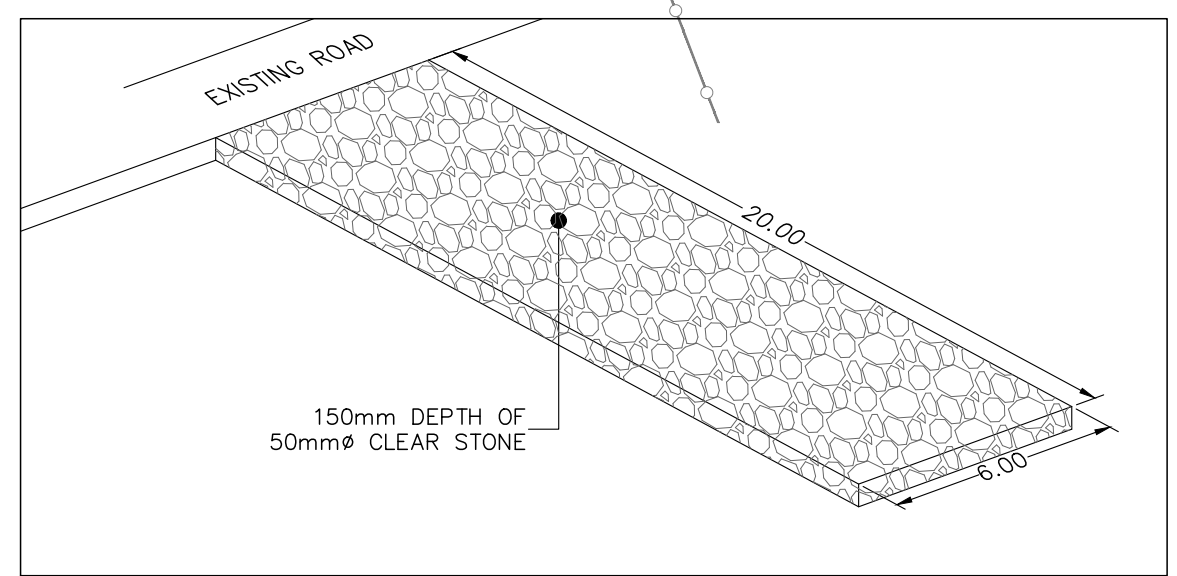

MUD MAT DETAIL
NOT TO SCALE

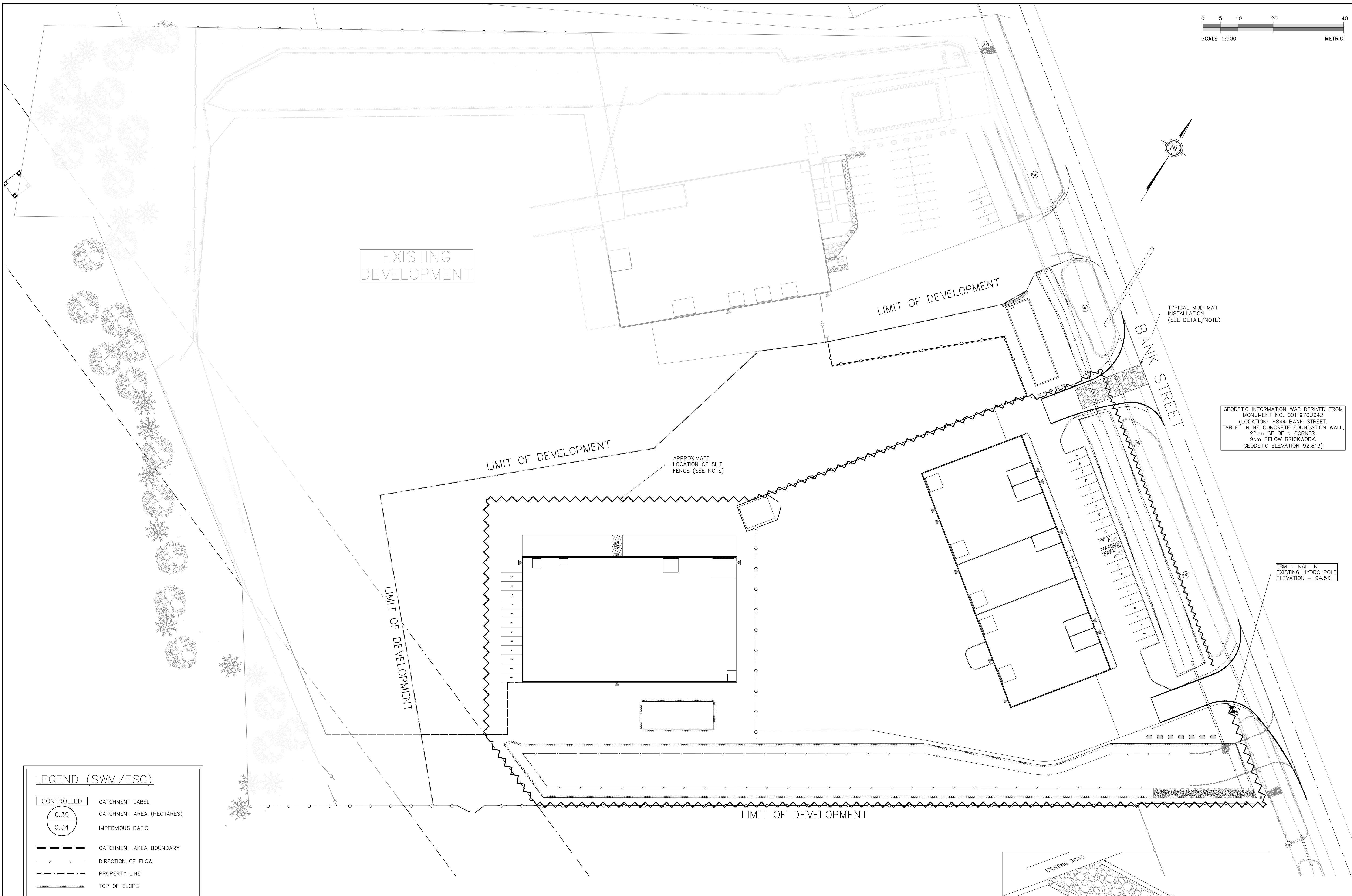

D07-12-24-0106

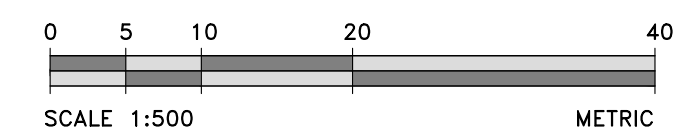

DRAWING NUMBER:
230156-PRE

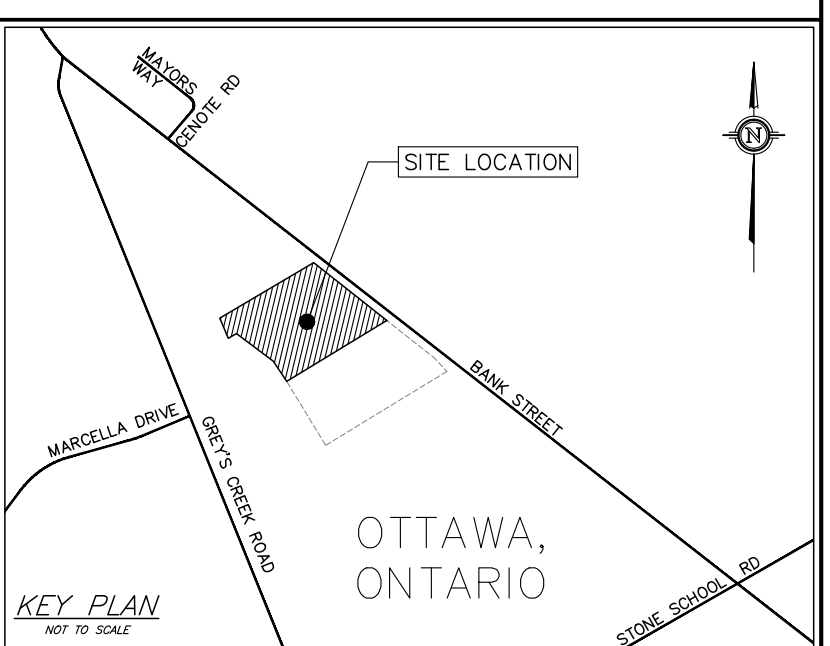

DRAWING:
PRE-DEVELOPMENT
DRAINAGE PLAN

- GENERAL NOTES:
1. ALL DIMENSIONS ARE IN METRES, UNLESS OTHERWISE SPECIFIED; ALL ELEVATIONS ARE IN METRES AND ARE GEODETIC.
 2. GEODETIC INFORMATION WAS DERIVED FROM MONUMENT NO. 0011970U042.
 3. TBM = NAIL IN EXISTING HYDRO POLE. ELEVATION = 94.53.
 4. THIS IS NOT A LEGAL SURVEY. BOUNDARY INFORMATION WAS DERIVED FROM PLAN 4R-25505. (SHIPMAN SURVEYING FILE NUMBER: 10-7-9718; HORIZONTAL DATUM: MTM ZONE 9, NAD 83)
 5. CLIENT IS RESPONSIBLE FOR ACQUIRING ALL NECESSARY PERMITS.
 6. CONTRACTOR TO VERIFY THAT APPROPRIATE PERMITS HAVE BEEN ACQUIRED PRIOR TO ANY CONSTRUCTION.
 7. CONTRACTOR IS RESPONSIBLE FOR LOCATION AND PROTECTION OF UTILITIES.
 8. ALL DIMENSIONS TO BE VERIFIED ON SITE BY CONTRACTOR PRIOR TO CONSTRUCTION.
 9. THIS DRAWING IS NOT FOR CONSTRUCTION UNTIL ALL APPROVALS HAVE BEEN GRANTED.
 10. HYDRO SERVICE TO BE INSTALLED ACCORDING TO THE SPECIFICATIONS OF SERVICE PROVIDER AND THE MECHANICAL ENGINEER.
 11. ALL MATERIALS AND CONSTRUCTION TO BE IN ACCORDANCE WITH CITY OF OTTAWA STANDARDS AND ONTARIO PROVINCIAL STANDARDS AND SPECIFICATIONS.
 12. ANY CHANGES MADE TO THIS PLAN MUST BE VERIFIED AND APPROVED BY KOLLAARD ASSOCIATES, INC.
 13. THIS DRAWING IS PART OF KOLLAARD ASSOCIATES DESIGN REPORTS #230156.

GEODETIC INFORMATION WAS DERIVED FROM MONUMENT NO. 0011970U042 (LOCATION: 6844 BANK STREET, TABLET IN RE CONCRETE FOUNDATION WALL, 22cm SE OF N CORNER, 9cm BELOW BRICKWORK, GEODETIC ELEVATION 92.613)

TBM = NAIL IN EXISTING HYDRO POLE ELEVATION = 94.53



LEGEND (SWM/ESC)

CONTROLLED	CATCHMENT LABEL
0.39	CATCHMENT AREA (HECTARES)
0.34	IMPERVIOUS RATIO
---	CATCHMENT AREA BOUNDARY
→	DIRECTION OF FLOW
---	PROPERTY LINE
---	TOP OF SLOPE
~~~~~	PROPOSED SILT FENCE
▨	CONTROLLED AREA
▩	UNCONTROLLED AREA
~~~~~	PRE-DEVELOPMENT DRAINAGE PATTERN
←	POST-DEVELOPMENT DRAINAGE PATTERN

PRE-DEVELOPMENT CONDITIONS
SCALE = 1:500

REV	BY	DATE	DESCRIPTION
3	ARK	JAN 10, 2024	REVISED FOR CITY COMMENTS
2	ARK	OCT 02, 2024	SHEET ADDED TO DRAWING SET

K Kollaard Associates Engineers

P.O. BOX 189, 210 PRESCOTT ST. (613) 860-0923
KEMPVILLE, ONTARIO info@kollaard.ca
KOG 1J0 FAX (613) 258-0475
http://www.kollaard.ca

CONSULTANTS:

H.A.KEN SHIPMAN SURVEYING LTD.
P.O. BOX 53, NORTH GOWER, ONT. K8A 2T0

JAMES B. LENNOX & ASSOCIATES INC.
LANDSCAPE ARCHITECTS
1100 WILSON AVENUE, OTTAWA, ONT. K1R 7S8

URBAN PLANNING CONSULTANTS
P. H. BROWN CONSULTANTS
2460 LANCETER ROAD, OTTAWA, ON K1B 4S5
TEL: (613) 725-1348

Castleglen Consultants
Engineers, Project Managers & Planners
2460 LANCETER ROAD, OTTAWA, ON K1B 4S5
TEL: (613) 725-1348

CLIENT:
Camm Warehousing and Rentals Inc.

PROJECT:
PROPOSED WAREHOUSE WITH OFFICE

LOCATION:
6622 BANK STREET, OTTAWA, ON

	DESIGNED BY: ARK	CHECKED BY: SD
	DRAWN BY: ARK	APPROVED BY: SD
DATE: JULY 31, 2024		SCALE: AS NOTED
PROJECT NUMBER: 230156		

© COPYRIGHT 2024
KOLLAARD ASSOCIATES INCORPORATED

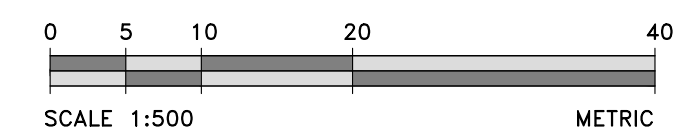

DRAWING NUMBER:
230156-POST

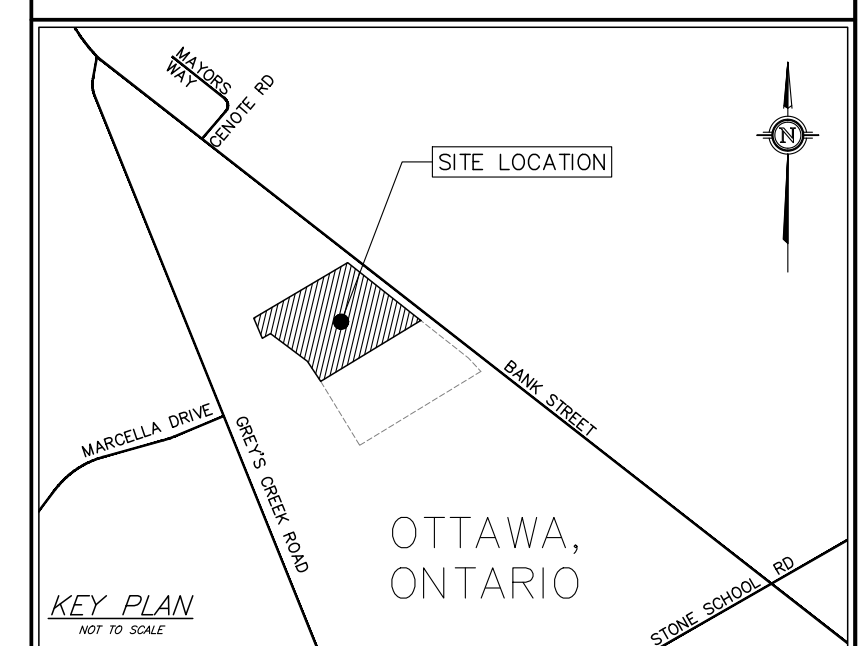

DRAWING:
POST-DEVELOPMENT
DRAINAGE PLAN

- GENERAL NOTES:
1. ALL DIMENSIONS ARE IN METRES, UNLESS OTHERWISE SPECIFIED; ALL ELEVATIONS ARE IN METRES AND ARE GEODETIC.
 2. GEODETIC INFORMATION WAS DERIVED FROM MONUMENT NO. 0011970U042.
 3. TBM = NAIL IN EXISTING HYDRO POLE. ELEVATION = 94.53.
 4. THIS IS NOT A LEGAL SURVEY. BOUNDARY INFORMATION WAS DERIVED FROM PLAN 4R-25595. (SHIPMAN SURVEYING FILE NUMBER: 10-7-9718; HORIZONTAL DATUM: MTM ZONE 9, NAD 83)
 5. CLIENT IS RESPONSIBLE FOR ACQUIRING ALL NECESSARY PERMITS.
 6. CONTRACTOR TO VERIFY THAT APPROPRIATE PERMITS HAVE BEEN ACQUIRED PRIOR TO ANY CONSTRUCTION.
 7. CONTRACTOR IS RESPONSIBLE FOR LOCATION AND PROTECTION OF UTILITIES.
 8. ALL DIMENSIONS TO BE VERIFIED ON SITE BY CONTRACTOR PRIOR TO CONSTRUCTION.
 9. THIS DRAWING IS NOT FOR CONSTRUCTION UNTIL ALL APPROVALS HAVE BEEN GRANTED.
 10. HYDRO SERVICE TO BE INSTALLED ACCORDING TO THE SPECIFICATIONS OF SERVICE PROVIDER AND THE MECHANICAL ENGINEER.
 11. ALL MATERIALS AND CONSTRUCTION TO BE IN ACCORDANCE WITH CITY OF OTTAWA STANDARDS AND ONTARIO PROVINCIAL STANDARDS AND SPECIFICATIONS.
 12. ANY CHANGES MADE TO THIS PLAN MUST BE VERIFIED AND APPROVED BY KOLLAARD ASSOCIATES, INC.
 13. THIS DRAWING IS PART OF KOLLAARD ASSOCIATES DESIGN REPORTS #230156.

GEODETIC INFORMATION WAS DERIVED FROM MONUMENT NO. 0011970U042 (LOCATION: 6844 BANK STREET, TABLET IN RE CONCRETE FOUNDATION WALL, 22cm SE OF N CORNER, 9cm BELOW BRICKWORK, GEODETIC ELEVATION 92.613)

TBM = NAIL IN EXISTING HYDRO POLE ELEVATION = 94.53

REV	BY	DATE	DESCRIPTION
3	ARK	JAN 10, 2024	REVISED FOR CITY COMMENTS
2	ARK	OCT 02, 2024	SHEET ADDED TO DRAWING SET

K Kollaard Associates
Engineers

P.O. BOX 189, 210 PRESCOTT ST. (613) 860-0923
KEMPVILLE, ONTARIO info@kollaard.ca
KOG 1J0 FAX (613) 258-0475
http://www.kollaard.ca

CONSULTANTS:

H.A.KEN SHIPMAN SURVEYING LTD. P.O. BOX 53 NORTH GOMER, ONT. K5A 2T0
JAMES B. LENNOX & ASSOCIATES INC. LANDSCAPE ARCHITECTS
P# R Business Consulting
URBAN PLANNING CONSULTING PROJECT MANAGEMENT
Castleglen Consultants
Engineers, Project Managers & Planners

CLIENT:
Camm Warehousing and Rentals Inc.

PROJECT:
PROPOSED WAREHOUSE WITH OFFICE

LOCATION:
6622 BANK STREET, OTTAWA, ON

DESIGNED BY: ARK CHECKED BY: SD
DRAWN BY: ARK APPROVED BY: SD
DATE: JULY 31, 2024
SCALE: AS NOTED
PROJECT NUMBER: 230156

L S. E. deWit
100079612
PROVINCE OF ONTARIO



POST-DEVELOPMENT CONDITIONS
SCALE = 1:500

LEGEND (SWM/ESC)

CONTROLLED

0.39 CATCHMENT LABEL
0.34 CATCHMENT AREA (HECTARES)
IMPERVIOUS RATIO

--- CATCHMENT AREA BOUNDARY
--- DIRECTION OF FLOW
--- PROPERTY LINE
--- TOP OF SLOPE

~ PROPOSED SILT FENCE

▨ CONTROLLED AREA
▩ UNCONTROLLED AREA

~ PRE-DEVELOPMENT DRAINAGE PATTERN
← POST-DEVELOPMENT DRAINAGE PATTERN

© COPYRIGHT 2024
KOLLAARD ASSOCIATES INCORPORATED