

SERVICING & STORMWATER MANAGEMENT REPORT

1531 ST. LAURENT BOULEVARD, OTTAWA

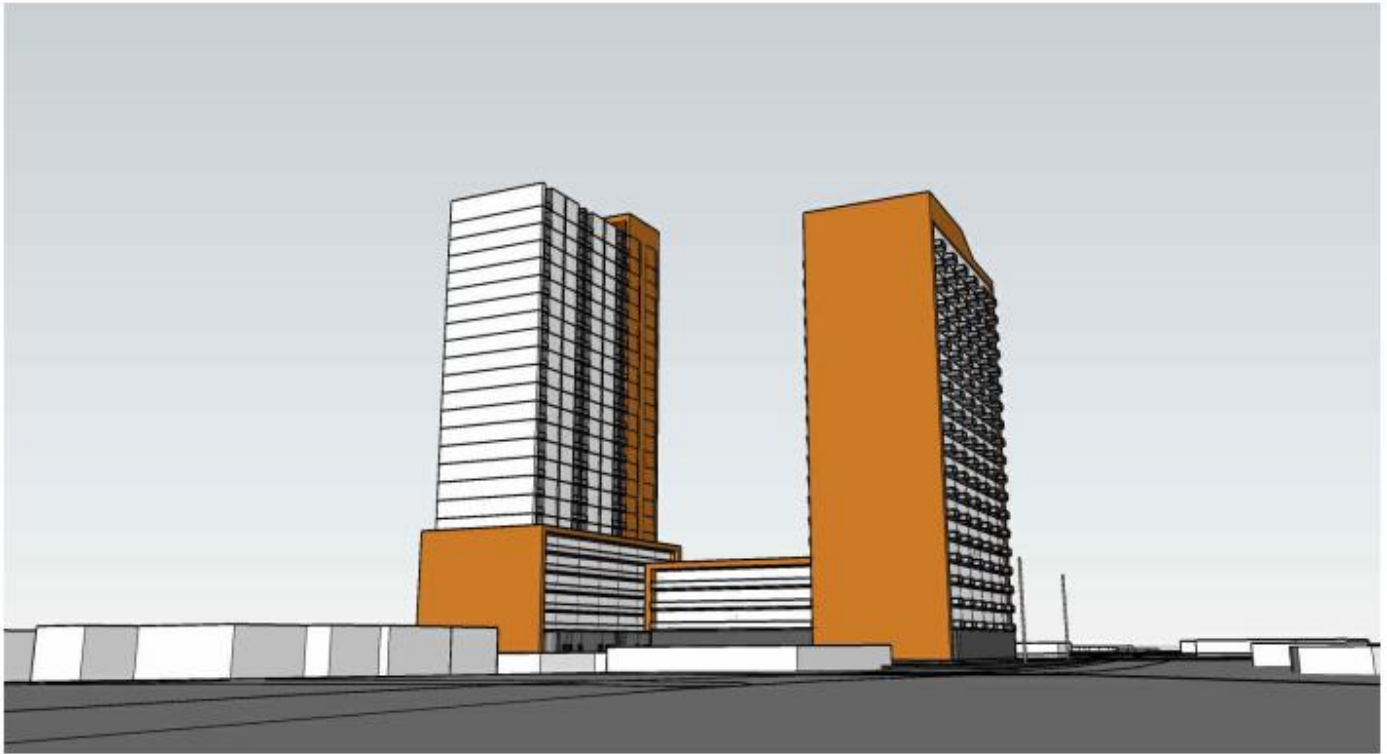

Project No.: CCO-23-4499

City File No.: D07-12-23-0059

Prepared for:

1531 St-Laurent Ltd.
69 Rue Jean-Proulx #301
Gatineau, QC J8Z 1W2

Prepared by:

Egis Canada Ltd.
750 Palladium Drive
Kanata, ON K2V 1C6

May 31, 2023

Revised: October 22, 2025
November 5, 2025

TABLE OF CONTENTS

1.0	PROJECT DESCRIPTION	1
1.1	<i>Purpose</i>	1
1.2	<i>Site Description</i>	1
1.3	<i>Proposed Development and Statistics</i>	2
1.4	<i>Existing Conditions and Infrastructure</i>	2
2.0	BACKGROUND STUDIES, STANDARDS, AND REFERENCES	3
2.1	<i>Background Reports / Reference Information</i>	3
2.2	<i>Applicable Guidelines and Standards</i>	4
3.0	PRE-CONSULTATION SUMMARY	4
4.0	WATERMAIN	6
4.1	<i>Existing Watermain</i>	6
4.2	<i>Proposed Watermain</i>	6
5.0	SANITARY DESIGN	9
5.1	<i>Existing Sanitary Sewer</i>	9
5.2	<i>Proposed Sanitary Sewer</i>	9
6.0	STORM SEWER DESIGN	11
6.1	<i>Existing Storm Sewers</i>	11
6.2	<i>Proposed Storm Sewers</i>	11
7.0	PROPOSED STORMWATER MANAGEMENT	12
7.1	<i>Design Criteria and Methodology</i>	12
7.2	<i>Runoff Calculations</i>	12
7.3	<i>Pre-Development Drainage</i>	13
7.4	<i>Post-Development Drainage</i>	13
8.0	EROSION AND SEDIMENT CONTROL	15
8.1	<i>Temporary Measures</i>	15
8.2	<i>Permanent Measures</i>	15
9.0	SUMMARY	17
10.0	RECOMMENDATION	18
11.0	STATEMENT OF LIMITATIONS	19

LIST OF TABLES

Table 1: Water Supply Design Criteria and Water Demands	7
Table 2: Fire Protection Confirmation	8
Table 3: Sanitary Design Criteria	9
Table 4: Summary of Estimated Sanitary Flow	10
Table 5: Pre-Development Runoff Summary	13
Table 6: Post-Development Runoff Summary	14

APPENDICES

Appendix A: Site Location Plan

Appendix B: City of Ottawa Pre-Consultation Notes

Appendix C: Watermain Calculations

Appendix D: Sanitary Calculations

Appendix E: Pre-Development Drainage Plan

Appendix F: Post-Development Drainage Plan

Appendix G: Stormwater Management Calculations

Appendix H: City of Ottawa Design Checklist

1.0 PROJECT DESCRIPTION

1.1 Purpose

Egis (formerly McIntosh Perry) has been retained by 1531 St-Laurent Limited Partnership to prepare this Servicing and Stormwater Management Report in support of the Site Plan Control application for the proposed 25 and 20-storey residential buildings, located at 1531 St. Laurent Boulevard within the City of Ottawa.

The main purpose of this report is to present a servicing design for the development in accordance with the recommendations and guidelines provided by the City of Ottawa (City), and the Ministry of the Environment, Conservation and Parks (MECP). This report will address the water, sanitary, and storm sewer servicing for the development, ensuring that existing and available services will adequately service the proposed development.

This report should be read in conjunction with the following drawings:

- CCO-23-4499, C101 – Site Grading and Drainage Plan,
- CCO-23-4499, C102 – Site Servicing Plan,
- CCO-23-4499, PRE – Pre-Development Drainage Area Plan (**Appendix E**), and
- CCO-23-4499, POST – Post-Development Drainage Area Plan (**Appendix F**)

1.2 Site Description

The property is located at 1531 St. Laurent Boulevard. It is described as Part of Lots 40, 41, 53 & 54, Registered Plan 63, Ward 18 Alta Vista, City of Ottawa. The land in question covers approximately **0.50 ha** and is bounded by St. Laurent Boulevard, Belfast Road, and Lagan Way. The development area for the proposed works is approximately **0.50 ha** which includes **0.05 ha** of parkland dedication fronting Belfast Road. The site is zoned as an Arterial Maintstreet Zone (AM). See Site Location Plan in **Appendix A** for more details.

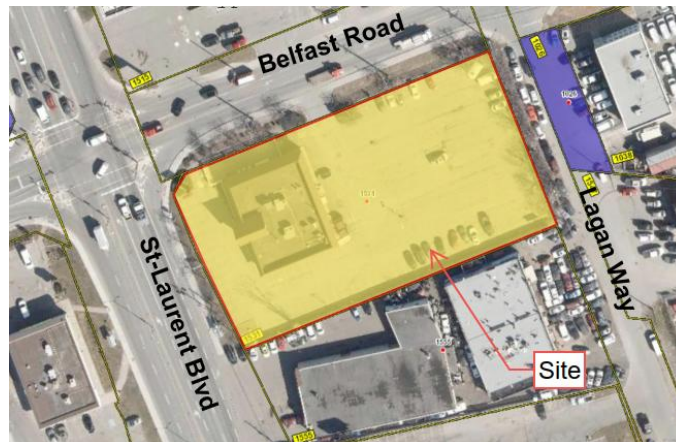

Figure 1: Site Map

1.3 Proposed Development and Statistics

The proposed development consists of two high rise residential towers. Visitor parking and drive aisles will be provided through an internal courtyard. Underground parking will be provided for residents and visitors with site accesses extending from Belfast Road and Lagan Way. Further details are provided in the Site Plan provided by Figurr Architects Collective. Refer to **Appendix B**.

1.4 Existing Conditions and Infrastructure

The existing site is currently developed as a restaurant complete with parking accessed from Belfast Road. It is assumed that sanitary and water servicing for the existing development is provided via services extending from the existing sewers within Belfast Road. Storm servicing for the site is provided by a series of private catch basins within the existing parking lot. It is assumed that the storm network conveys runoff to the storm sewer within Belfast Road.

Sewer and watermain mapping collected from the City of Ottawa indicate that the following services exist across the property frontages within the adjacent municipal rights-of-way(s):

- **St. Laurent Boulevard**
 - 406mm diameter cast iron watermain, and a
 - 1200mm diameter concrete storm sewer, tributary to the South Cyrville Drain with approximately 0.70 Km to the outlet.

- **Belfast Road**
 - 305mm diameter cast iron watermain,
 - 250mm diameter PVC sanitary sewer, tributary to the Innes Road Collector, and a

- 1200mm diameter concrete storm sewer, tributary to the South Cyrville Drain with approximately 0.70 Km to the outlet.

- **Lagan Way**
 - 203mm diameter PVC watermain,
 - 250mm diameter PVC sanitary sewer, tributary to the Innes Road Collector, and a
 - 750mm diameter concrete storm sewer, tributary to the South Cyrville Drain with approximately 0.70 Km to the outlet.

1.5 Approvals

The proposed development is subject to the City of Ottawa site plan control process. Site plan control requires the City to review, provided concurrence and approve the engineering design package. Permits to construct can be requested once the City has issued a site plan agreement.

An Environmental Compliance Approval (**ECA**) through the Ministry of Environment, Conservation and Parks (**MECP**) is not anticipated to be required for the development since the development is contained within a single parcel of land, is not within a combined sewershed, and does not propose industrial sewage. As a result, the stormwater management system meets the exemption requirements under O.Reg 525/90.

2.0 BACKGROUND STUDIES, STANDARDS, AND REFERENCES

2.1 Background Reports or Referenced Information

Background studies that have been referenced or completed for the proposed site include City of Ottawa as-built drawings and a topographical survey.

As-built drawings of existing services within the vicinity of the proposed site were reviewed in order to determine accurate servicing and stormwater management schemes for the site.

A topographic survey of the site (File No. 432-22) was completed by Farley, Smith & Denis Surveying LTD., dated August 25, 2022.

2.2 Applicable Guidelines and Standards

City of Ottawa:

- ◆ Ottawa Sewer Design Guidelines, City of Ottawa, SDG002, October 2012. (***Ottawa Sewer Guidelines***)
 - Technical Bulletin ISTB-2014-01 City of Ottawa, February 2014. (***ISTB-2014-01***)
 - Technical Bulletin PIEDTB-2016-01 City of Ottawa, September 2016. (***PIEDTB-2016-01***)
 - Technical Bulletin ISTB-2018-01 City of Ottawa, January 2018. (***ISTB-2018-01***)
 - Technical Bulletin ISTB-2018-03 City of Ottawa, March 2018. (***ISTB-2018-03***)
 - Technical Bulletin ISTB-2019-01 City of Ottawa, January 2019. (***ISTB-2019-01***)
 - Technical Bulletin ISTB-2019-02 City of Ottawa, February 2019. (***ISTB-2019-02***)
- ◆ Ottawa Design Guidelines – Water Distribution City of Ottawa, July 2010. (***Ottawa Water Guidelines***)
 - Technical Bulletin ISD-2010-2 City of Ottawa, December 15, 2010. (***ISD-2010-2***)
 - Technical Bulletin ISDTB-2014-02 City of Ottawa, May 2014. (***ISDTB-2014-02***)
 - Technical Bulletin ISTB-2018-02 City of Ottawa, March 2018. (***ISTB-2018-02***)

Ministry of Environment, Conservation and Parks:

- ◆ Stormwater Planning and Design Manual, Ministry of the Environment, March 2003. (***MECP Stormwater Design Manual***)
- ◆ Design Guidelines for Sewage Works, Ministry of the Environment, 2008. (***MECP Sewer Design Guidelines***)

Other:

- ◆ Water Supply for Public Fire Protection, Fire Underwriters Survey, 2020. (***FUS Guidelines***)

3.0 PRE-CONSULTATION SUMMARY

A pre-consultation meeting was conducted on October 26, 2022 regarding the proposed site. Specific design parameters to be incorporated within this design include the following:

- Control post-development flows to the 2-year pre-development storm with a maximum combined C value of 0.50, and calculated time of concentration.

- Flows to the storm sewer in excess of the 2-year storm release rate, up to and including the 100-year storm event, must be detained on site.
- No surface ponding within parking areas during the 2-year event.

The notes from the City of Ottawa can be found in **Appendix B**.

4.0 WATERMAIN

4.1 Existing Watermain

The site is located within the 1E pressure zone, as per the Water Distribution System mapping included in **Appendix C**. There is an existing 305mm diameter CI watermain within Belfast Road. The watermain also provides servicing to the municipal fire hydrant along the south side of Belfast Road.

4.2 Proposed Watermain

Two new 150mm diameter PVC water services are proposed to service the development, complete with water valves located at the property line. The water services are proposed to be serviced by the existing 305mm diameter watermain within Belfast Road. The services are designed to have a minimum of 2.4m cover. Refer to drawing **C102** for a detailed servicing layout.

The Fire Underwriters Survey 2020 (FUS) method was utilized to determine the required fire flow for the site. The 'C' factor (type of construction) for the FUS calculation was determined to be 0.8 (non-combustible type). The total effective floor area ('A' value) for the FUS calculation was determined to be **4,577.0 m²** for Tower A and **5,150.0 m²** for Tower B. The results of the calculations yielded a required maximum fire flow of **8,000 L/min**. The detailed calculations for the FUS can be found in **Appendix C**.

The water demands for the proposed building have been calculated to adhere to the **Ottawa Design Guidelines – Water Distribution** manual and can be found in **Appendix C**. The results have been summarized in **Table 1**, below. In accordance with Section 4.3.1 of the guidelines, service areas with a basic day demand greater than 50 m³/day require a dual connection to the municipal system. The basic day demand for the development is estimated to be **210 m³/day**, therefore a dual connection is required.

Table 1: Water Supply Design Criteria and Water Demands

Site Area	0.50 ha
Residential	280 L/person/day
1 Bedroom Apartment	1.4 persons/unit
2 Bedroom Apartment	2.1 persons/unit
3 Bedroom Apartment	3.1 persons/unit
Bachelor Apartment	1.4 persons/unit
Maximum Daily Peaking Factor	2.5 x avg day
Maximum Hour Peaking Factor	2.2 x max day
Average Day Demand (L/s)	2.53
Maximum Daily Demand (L/s)	6.31
Peak Hourly Demand (L/s)	13.87
FUS Fire Flow Requirement (L/s) 25-Storey Building	100.00 (6,000L/min)
FUS Fire Flow Requirement (L/s) 20-Storey Building	100.00 (6,000 L/min)

The City previously provided the estimated water pressures at both connections for the average day scenario, peak hour scenario, and the max day plus fire flow scenario for the demands indicated by the correspondence in **Appendix C**. The boundary condition results were based on the previously calculated Fire Flow Requirement of 8,000L/min, included in the previous Servicing & Stormwater Management Report (May 31, 2023, McIntosh Perry). To be conservative, a fire flow of 8,000L/min (133.33L/s) was used in the water model. The resulting pressures for the boundary conditions results are shown in **Table 2**, below.

Table 2: Boundary Conditions Results

Scenario	Proposed Demands (L/s) **	Connection HGL (m H ₂ O)* / kPa
Average Day Demand	2.43	52.2 / 511.9
Maximum Daily + Fire Flow Demand	139.40	46.4 / 455.0
Peak Hourly Demand	13.36	44.0 / 431.4
<p><i>*Adjusted for an estimated ground elevation of 66.02m above the connection point.</i></p> <p><i>** Proposed demands based on water demand calculations at the time of the boundary condition request to the City. Updated demands in Table 1 above, although slightly higher than those included in the boundary condition, are not expected to affect the results of the water model.</i></p>		

The normal operating pressure range is anticipated to be 431 kPa to 512 kPa and will not be less than 275 kPa (40 psi) or exceed 689 kPa (100 psi). The proposed water services will meet the minimum required 20 psi (140 kPa) at the ground level under maximum day demand and fire flow conditions.

To confirm the adequacy of fire flow to protect the proposed development, public fire hydrants within 150 m of the proposed building were analysed per City of Ottawa **ISTB 2018-02** Appendix I Table 1. Based on City guidelines (**ISTB-2018-02**), the existing hydrants can provide adequate fire protection to the proposed development. The results are summarized in **Table 3**, below.

Table 3: Fire Protection Confirmation

Building	Fire Flow Demand (L/min.)	Fire Hydrant(s) within 75m	Fire Hydrant(s) within 150m	Combined Fire Flow (L/min.)
1531 St. Laurent Boulevard, 25-Storey	6,000 (FUS)	2	4	26,600
1531 St. Laurent Boulevard, 20-Storey	6,000 (FUS)	2	4	26,600

**Fire hydrants within 75 metres contribute 5,700 L/min to fire flow and fire hydrants within 150 meters contribute 3,800 L/min to fire flow, respectively, per ISTB-2018-02.*

5.0 SANITARY DESIGN

5.1 Existing Sanitary Sewer

There is an existing 250mm diameter PVC sanitary sewer within Belfast Road.

5.2 Proposed Sanitary Sewer

A new 200 mm diameter gravity sanitary service is proposed be connected to the existing 250mm diameter sanitary sewer within Belfast Road. A maintenance hole (**MH1A**) is proposed at the property to provide monitoring per the *Ottawa Sewer Design Guidelines* and *City of Ottawa Sewer-Use By-Law 2003-514 (14)*.

The peak design flows for the proposed building were calculated using criteria from the *Ottawa Sewer Guidelines* and are summarized in **Table 4**, below. Based on the unit occupancy statistics provided by the architect, the proposed site development will generate a flow of **8.23 L/s**. See **Appendix D** of this report for more details.

Table 4: Sanitary Design Criteria

Design Parameter	Value
Site Area	0.50 ha
Residential	280 L/person/day
Commercial/Amenity	2,800 L/(m ² /day)
1 Bedroom Apartment	1.4 persons/unit
2 Bedroom Apartment	2.1 persons/unit
3 Bedroom Apartment	3.1 persons/unit
Bachelor Apartment	1.4 persons/unit
Residential Peaking Factor	3.30
Extraneous Flow Allowance	0.33 L/s/ha

Table 5, below, summarizes the estimated wastewater flow from the proposed development. Refer to **Appendix D** for detailed calculations.

Table 5: Summary of Estimated Sanitary Flow

Design Parameter	Total Flow (L/s)
Total Estimated Average Dry Weather Flow	2.60
Total Estimated Peak Dry Weather Flow	8.36
Total Estimated Peak Wet Weather Flow	8.50

The proposed 200 mm diameter gravity sanitary service will be installed with a minimum full flow target velocity (cleansing velocity) of 0.6 m/s and a full flow velocity of not more than 3.0 m/s. The capacity of the service lateral is 33.74 L/s at a proposed slope of 1.00%. The City has advised that there are no downstream constraint for the estimated sanitary flow from the site. See **Appendix D** of this report for more details.

6.0 STORM SEWER DESIGN

6.1 Existing Storm Sewers

Water runoff from the site is currently tributary to the South Cyrville Drain within the Ottawa River East Subwatershed. The subject property is currently serviced by a series of private catch basins within the parking lot area surrounding the existing building/ There is an existing 1200mm diameter storm sewer within Belfast Road that is available to service the site.

6.2 Proposed Storm Sewers

A new 300mm PVC storm service will be extended from the existing 1200mm diameter storm sewer within Belfast Road. The sewer system will provide attenuation for the roof area and drive aisle/entrance area by an internal cistern which will discharge to the city sewer at a controlled rate via pumps. A cistern detail has been provided as part of the Architectural submission package.

Foundation drainage is proposed to be pumped without attenuation via the 300mm diameter storm service downstream of any cistern controls.

See CCO-23-4499 - *POST* include in **Appendix F** of this report for more details. The Stormwater Management design for the subject property will be outlined in **Section 7.0** of this report.

7.0 PROPOSED STORMWATER MANAGEMENT

7.1 Design Criteria and Methodology

Stormwater management for the proposed site will be maintained through the use of an internal cistern and will collect runoff from the at-grade areas within the site. The flow will be directed to the existing 1200mm diameter storm sewer within Belfast Road.

The following design criteria have been employed in developing the stormwater management design for the site as coordinated with the City. Please note the following methodology is based upon further coordination with the City and supersedes the requirements outlined in the pre-consultation notes.

Quality Control

- Based on the distance to the downstream storm outlet being less than 2 Km, it has been assumed that enhanced level quality control measures are required (80% TSS removal).

Quantity Control

- Pre-development time of concentration (TC) shall be calculated and be no less than 10 minutes.
- Control site post-development flows to the 2-year pre-development flows with a combined C value of no greater than 0.50.

7.2 Runoff Calculations

Runoff calculations presented in this report are derived using the Rational Method, given as:

$$Q = 2.78CIA \text{ (L/s)}$$

Where	C	= Runoff coefficient
	I	= Rainfall intensity in mm/hr (City of Ottawa IDF curves)
	A	= Drainage area in hectares

It is recognized that the Rational Method tends to overestimate runoff rates. As a result, the conservative calculation of runoff ensures that any SWM facility sized using this method is expected to function as intended.

The following coefficients were used to develop an average C for each area:

Roofs/Concrete/Asphalt	0.90
Gravel	0.60
Undeveloped and Grass	0.20

As per the *City of Ottawa - Sewer Design Guidelines*, the 5-year balanced 'C' value must be increased by 25% for a 100-year storm event to a maximum of 1.0.

As per coordination with the City of Ottawa the time of concentration (Tc) used for pre-development shall be calculated but not less than a Tc of 10 minutes and post-development flows shall be calculated using a Tc of 10 minutes. The calculated Tc in pre-development conditions is less than 10 minutes, therefore, a Tc of 10 minutes was used in the pre-development runoff calculations. Refer to **Appendix G**.

7.3 Pre-Development Drainage

It has been assumed that the site contains no stormwater management controls for flow attenuation. The estimated pre-development peak flows for the 5, and 100-year events are summarized below in **Table 5**. See CCO-23-4499 - PRE in **Appendix E** and **Appendix G** for calculations.

Table 6: Pre-Development Runoff Summary

Drainage Area	Area (ha)	Q (L/s)		
		2-Year	5-Year	100-Year
A1	0.45*	85.28	115.69	220.38
Total	0.45	85.28	115.69	220.38

**Total Site Area Less Parkland Dedication*

7.4 Post-Development Drainage

The proposed site drainage limits are demonstrated on the Post-Development Drainage Area Plan. See CCO-23-4499 - POST in **Appendix F** of this report for more details. Based on the quantity control criteria discussed in **Section 7.1** and a site area of **0.45 ha**, post development drainage from the site is to be limited to a maximum release rate of **47.88 L/S**. A summary of the Post-Development Runoff Calculations can be found below.

Table 7: Post-Development Runoff Summary

Drainage Area	Area (ha)	C 5 Year	5-year Peak Flow (L/s)	C 100 Year	100-year Peak Flow (L/s)	100-year Storage Required (m ³)	100-year Storage Available (m ³)
B1	0.39	0.84	14.35	0.93	27.34	115.9	115.9
B2	0.06	0.55	10.08	0.63	19.62	-	-
Total	0.45		24.42		46.96	115.9	115.9

Runoff for area B1 will be collected by roof drains (uncontrolled) and surface drains and conveyed to the internal cistern. The **115.9 m³** internal cistern is anticipated to convey stormwater to the outlet at a maximum flow rate of **14.35 L/s** and **27.34 L/s** for the 5 and 100-year storms, respectively. Flows in excess of the 100-year storm event will need to be directed Belfast Road via a cistern overflow. The cistern details have been provided by the Architect as part of the resubmission package, however, it is anticipated that the cistern will be equipped with pumps to discharge flows and control release rates.

Foundation drainage is proposed to be pumped to the 300 mm storm service without attenuation, downstream of cistern controls.

0.05 ha of the site is proposed to be conveyed to the City as parkland and has not been included in the Post-Development Runoff Summary. Runoff from the parkland is proposed to flow overland without attenuation towards Belfast Road and Lagan Way.

7.5 Quality Controls

A Stormceptor EF04 OGS unit (or approved equivalent) will provide quality control for the site. Runoff from area B1 will be conveyed from the cistern to the OGS unit which will provide 80% TSS removal prior to discharging to the municipal storm sewer. It is anticipated that the OGS will act as a monitoring port for storm water leaving the site. Refer to **Appendix G**.

8.0 EROSION AND SEDIMENT CONTROL

8.1 Temporary Measures

Before construction begins, temporary silt fence, straw bale or rock flow check dams will be installed at all natural runoff outlets from the property. Silt sack inserts must be installed at existing catch basins as specified on plan **C101**. It is crucial that these controls be maintained throughout construction and inspection of sediment and erosion control will be facilitated by the Contractor or Contract Administration staff throughout the construction period.

Silt fences will be installed where shown on the final engineering plans, specifically along the downstream property limits. The Contractor, at their discretion or at the instruction of the City, Conservation Authority or the Contract Administrator shall increase the quantity of sediment and erosion controls on-site to ensure that the site is operating as intended and no additional sediment finds its way off site. The rock flow, straw bale & silt fence check dams and barriers shall be inspected weekly and after rainfall events. Care shall be taken to properly remove sediment from the fences and check dams as required. Fibre roll barriers are to be installed at all existing curb inlet catchbasins and filter fabric is to be placed under the grates of all existing catchbasins and manholes along the frontage of the site and any new structures immediately upon installation. The measures for the existing/proposed structures is to be removed only after all areas have been paved. Care shall be taken at the removal stage to ensure that any silt that has accumulated is properly handled and disposed of. Removal of silt fences without prior removal of the sediments shall not be permitted.

Although not anticipated, work through winter months shall be closely monitored for erosion along sloped areas. Should erosion be noted, the Contractor shall be alerted and shall take all necessary steps to rectify the situation. Should the Contractor's efforts fail at remediating the eroded areas, the Contractor shall contact the City and/or Conservation Authority to review the site conditions and determine the appropriate course of action. As the ground begins to thaw, the Contractor shall place silt fencing at all required locations as soon as ground conditions warrant. Please see the *Site Grading, Drainage and Sediment & Erosion Control Plan* for additional details regarding the temporary measures to be installed and their appropriate OPSD references.

8.2 Permanent Measures

Rip-rap will be placed at all locations that have the potential for concentrated flow. It is crucial that the Contractor ensure that the geotextile is keyed in properly to ensure runoff does not undermine the rip rapped area. Additional rip rap is to be placed at erosion prone locations as identified by the Contractor / Contract Administrator / City or Conservation Authority.

It is expected that the Contractor will promptly ensure that all disturbed areas receive topsoil and seed/sod and that grass be established as soon as possible. Any areas of excess fill shall be removed or levelled as soon as possible and must be located a sufficient distance from any watercourse to ensure that no sediment is washed out into the watercourse. As the vegetation growth within the site provides a key component to the control of sediment for the site, it must be properly maintained once established. Once the construction is complete, it will be up to the landowner to maintain the vegetation and ensure that the vegetation is not overgrown or impeded by foreign objects.

9.0 SUMMARY

- Two residential towers are proposed to be constructed at 1531 St. Laurent Boulevard.
- Two 150mm diameter water services are proposed to be connected to the existing 305mm diameter within Belfast Road.
- A new 200 mm diameter sanitary service is proposed, complete with a monitoring maintenance hole at the property line, to service the development via the 250mm diameter sanitary sewer within Belfast Road tributary to the Innes Road Collector.
- A new 300mm storm service for rooftop, surface, and foundation drainage is proposed to service the development. The storm service will connect to the 1200mm diameter storm sewer within Belfast Road, tributary to the South Cyrville Drain approximately 0.70 Km downstream.
- Storage for the 5- through 100-year storm events will be provided through internal cistern attenuation.
- Quality control will be provided for the development via an OGS unit.

10.0 RECOMMENDATION

Based on the information presented in this report, we recommend that City of Ottawa approve this Servicing and Stormwater Management Report in support of the proposed development at 1531 St. Laurent Boulevard

This report is respectfully being submitted for approval.

Regards,

Egis Canada Ltd.

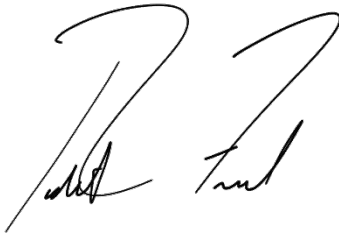

Robert D. Freel, P.Eng.
Senior Project Engineer, Sustainable Cities
T: 613.714.6174
E: robert.freel@egis-gorup.comn



Alison Gosling
Project Engineer, Sustainable Cities
T: 613.714.4629
E: alison.gosling@egis-group.com

u:\infrastructure\2023\cco-23-4499 1531 st-laurent ltd partnership - 1531 st. laurent blvd\03 - servicing\report\cco-23-4499_servicing report.docx

APPENDIX A
KEY PLAN

APPENDIX B
BACKGROUND DOCUMENTS

1531 St. Laurent Blvd
Meeting Summary Notes
October 26, 2022. Online Teams Meeting

Attendees:

- Jillian Simpson
- Paul Black
- Chaxu Baria
- Tanya Chowieri
- Katie Morphet (File Lead, Planner, City of Ottawa)
- Bruce Bramah (Project Manager, City of Ottawa)
- Mark Richardson (Forestry, City of Ottawa)
- Hayley Murray (Forestry, City of Ottawa)
- Randolph Wang (Urban Design, City of Ottawa)
- Steve Gauthier (Parks, City of Ottawa)

Not in Attendance:

- Matthew Hayley (Environmental Planner, City of Ottawa)
- Mike Giampa (Senior Transportation Project Manager, City of Ottawa)

Issue of Discussion:

- Site Plan Control for two towers (25 storeys and 20 storeys) containing approximately 421 units with 474m² of commercial at-grade in Building A. 561 parking spaces provided (underground + surface), amenity space, parkland dedication @10%



1. Infrastructure/Servicing – Bruce Bramah

See Attached

2. Initial Planning Comments – Katie Morphet

- Please include zoning table on site plan to identify all required zone and applicable general provisions and that they are being met.
- A Survey Plan will be required to clarify property boundaries and lot ownership.
- A Planning brief outlines how the proposed plan meets the Zoning By-law and Official Plan policies will be required.

3. Urban Design (Randolph Wang)

1. A Design Brief is required. The Terms of Reference of the Design Brief is attached for convenience.
 - a. Please study alternative site plan and massing, and compare the pros and cons of these options.
 - b. Please note both a wind study and a shadow study is required.
2. The site is within a Design Priority Area. Formal review by the City's Urban Design Review Panel is required. Please contact udrp@ottawa.ca or visit the City's UDRP website for scheduling details and submission requirements.
3. Please retain services of an architect and a landscape architect. Such services are crucial in the investigation of design alternatives and preparation of appropriate design materials.

4. With respect to the materials presented at the preconsultation meeting, urban design appreciates the images that show the potential “highest and best uses” in the vicinities but caution the limitations of these images. A more thorough and comprehensive study is required with respect to not only the potential “highest and best uses” of lands, but also the framework and elements of the new community.
5. The conceptual site plan shows the potential density that can be contemplated when the general rules around the high-rise development are followed. There were discussions about the location of the proposed park, which is one of the key factors that will influence the site plan. As indicated above, alternative site plan option and massing options should be explored. When exploring the alternative options, please consider the following (in addition to the location of the municipal park):
 - a. Relationship with potential future development on the property to the south of the subject property.
 - b. Function and characteristics of Lagan Way.
 - c. Cross section design of St Laurent and Belfast.
 - d. Functional requirements for viable commercial and their relationship with residential uses.
 - e. Impacts on the solar panels on the building across from St. Laurent.
 - f. How will this development stimulates community building.

4. Parks – Steve Gauthier

The proposed park location is not acceptable. The park should be located at the corner of Belfast Rd and Lagan Way, or to the south-east of the property for potential consolidation with future park development to the south.

5. Trees – Hayley Murray

Project Comments:

- All City owned trees must be retained and mitigation measures, if work is to occur in the CRZ of these trees, must be detailed in the TCR.
 - o If a City owned tree is proposed for removal it must be justified and the applicant can expect to pay monetary compensation.
- Planting large canopy trees in the parkland area would be ideal.

TCR requirements:

1. A Tree Conservation Report (TCR) must be supplied for review along with the suite of other plans/reports required by the City
 - a. an approved TCR is a requirement of Site Plan approval.
 - b. The TCR may be combined with the LP provided all information is supplied

2. Any removal of privately-owned trees 10cm or larger in diameter, or city-owned trees of any diameter requires a tree permit issued under the Tree Protection Bylaw (Bylaw 2020 – 340); the permit will be based on an approved TCR and made available at or near plan approval.
3. The Planning Forester from Planning and Growth Management as well as foresters from Forestry Services will review the submitted TCR
 - a. If tree removal is required, both municipal and privately-owned trees will be addressed in a single permit issued through the Planning Forester
 - b. Compensation may be required for city owned trees – if so, it will need to be paid prior to the release of the tree permit
4. The TCR must contain 2 separate plans:
 - a. Plan/Map 1 - show existing conditions with tree cover information
 - b. Plan/Map 2 - show proposed development with tree cover information
 - c. Please ensure retained trees are shown on the landscape plan
5. The TCR must list all trees on site, as well as off-site trees if the CRZ extends into the developed area, by species, diameter and health condition
 - a. please identify trees by ownership – private onsite, private on adjoining site, city owned, boundary (trees on a property line)
6. If trees are to be removed, the TCR must clearly show where they are, and document the reason they cannot be retained
7. All retained trees must be shown, and all retained trees within the area impacted by the development process must be protected as per City guidelines available at [Tree Protection Specification](#) or by searching Ottawa.ca
8. The location of tree protection fencing must be shown on the plan
9. The City encourages the retention of healthy trees; if possible, please seek opportunities for retention of trees that will contribute to the design/function of the site.
10. For more information on the process or help with tree retention options, contact Hayley Murray hayley.murray@ottawa.ca or on [City of Ottawa](#)

LP tree planting requirements:

For additional information on the following please contact tracy.smith@Ottawa.ca

Minimum Setbacks

- Maintain 1.5m from sidewalk or MUP/cycle track or water service laterals.
- Maintain 2.5m from curb
- Coniferous species require a minimum 4.5m setback from curb, sidewalk or MUP/cycle track/pathway.
- Maintain 7.5m between large growing trees, and 4m between small growing trees. Park or open space planting should consider 10m spacing, except where otherwise approved in naturalization / afforestation areas. Adhere to Ottawa Hydro's planting guidelines (species and setbacks) when planting around overhead primary conductors.

Tree specifications

- Minimum stock size: 50mm tree caliper for deciduous, 200cm height for coniferous.
- Maximize the use of large deciduous species wherever possible to maximize future canopy coverage
- Tree planting on city property shall be in accordance with the City of Ottawa's Tree Planting Specification; and include watering and warranty as described in the specification (can be provided by Forestry Services).
- Plant native trees whenever possible
- No root barriers, dead-man anchor systems, or planters are permitted.
- No tree stakes unless necessary (and only 1 on the prevailing winds side of the tree)

Hard surface planting

- Curb style planter is highly recommended
- No grates are to be used and if guards are required, City of Ottawa standard (which can be provided) shall be used.
- Trees are to be planted at grade

Soil Volume

- Please document on the LP that adequate soil volumes can be met:

Tree Type/Size	Single Tree Soil Volume (m3)	Multiple Tree Soil Volume (m3/tree)
Ornamental	15	9
Columnar	15	9
Small	20	12
Medium	25	15
Large	30	18
Conifer	25	15

Please note that these soil volumes are not applicable in cases with Sensitive Marine Clay.

- Please follow the City's 2017 Tree Planting in Sensitive Marine Clay guidelines

Tree Canopy

- The landscape plan shall show how the proposed tree planting will replace and increase canopy cover on the site over time, to support the City's 40% urban forest canopy cover target.
- At a site level, efforts shall be made to provide as much canopy cover as possible, through tree planting and tree retention, with an aim of 40% canopy cover at 40 years, as appropriate.
- Indicate on the plan the projected future canopy cover at 40 years for the site.

6. Environment – Matthew Hayley

Urban Heat Island Effect

Please add features that reduce the urban heat island effect (see OP 10.3.3) produced by the parking lot and a building footprint. For example, this impact can be reduced by adding large canopy trees, green roofs or vegetation walls, or constructing the parking lot or building differently.

Bird-safe Development

Please review and incorporate bird safe design elements. Some of the risk factors include glass and related design traps such as corner glass and fly-through conditions, ventilation grates and open pipes, landscaping, light pollution. More guidance and solutions are available in the guidelines which can be found here: https://documents.ottawa.ca/sites/documents/files/birdsafedesign_guidelines_en.pdf

7. South Nation Conservation

The downstream storm water outlet is just over 700 metres from the site without any downstream stormwater management facility. Therefore, on-site water quality of 'enhanced' (80% TSS Removal) would be required. The applicant is strongly encouraged to incorporate LIDs into the stormwater management strategy.

8. Transportation – Mike Giampa

A TIA is warranted- proceed to scoping.

The application will not be deemed complete until the submission of the draft step 2-4, including the functional draft RMA package (if applicable) and/or monitoring report (if applicable).

Although a full review of the TIA Strategy report (Step 4) is not required prior to an application, it is strongly recommended. Synchro files are required at Step 4.

ROW protection on St Laurent Boulevard is 44.5 metres.

A Noise Impact Study is required

Due to the northbound right-turn channel, relocating the Belfast access away from the intersection is recommended.

On site plan:

Show all details of the roads abutting the site up to and including the opposite curb; include such items as pavement markings, accesses and/or sidewalks.

Turning templates will be required for all accesses showing the largest vehicle to access the site; required for internal movements and at all access (entering and exiting and going in both directions).

Show all curb radii measurements; ensure that all curb radii are reduced as much as possible

9. General Information

- a. Ensure that all plans and studies are prepared as per City guidelines – as available online...

<https://ottawa.ca/en/city-hall/planning-and-development/information-developers/development-application-review-process/development-application-submission/guide-preparing-studies-and-plans>

PLEASE NOTE: Due to implementation of Bill 109 should the application associated with this pre-consultation meeting be filled with the City and deemed adequate on or after January 1st, 2023 a new pre-consultation process may need to be undertaken.

MEMO

Date:

To /
Destinataire Katie Morphet, Planner

From /
Expéditeur Bruce Bramah, Project Manager, Infrastructure
Approvals

Pre-Application Consultation
1531 St Laurent, File No. PC2022-0271
Subject / *Two towers containing approximately 421 units*
Objet *with 474 m² of commercial at grade in building.*
561 underground and surface parking spaces
provided.

Please note the following information regarding the engineering design submission for the above noted site:

1. The Servicing Study Guidelines for Development Applications are available at the following address: <https://ottawa.ca/en/planning-development-and-construction/developing-property/development-application-review-process/development-application-submission/guide-preparing-studies-and-plans#servicing-study-guidelines-development-applications>
2. Servicing and site works shall be in accordance with the following documents:
 - ⇒ Ottawa Sewer Design Guidelines (October 2012)
 - ⇒ Ottawa Design Guidelines – Water Distribution (2010)
 - ⇒ Geotechnical Investigation and Reporting Guidelines for Development Applications in the City of Ottawa (2007)
 - ⇒ City of Ottawa Slope Stability Guidelines for Development Applications (revised 2012)
 - ⇒ City of Ottawa Environmental Noise Control Guidelines (January, 2016)
 - ⇒ City of Ottawa Park and Pathway Development Manual (2012)
 - ⇒ City of Ottawa Accessibility Design Standards (2012)

- ⇒ Ottawa Standard Tender Documents (latest version)
 - ⇒ Ontario Provincial Standards for Roads & Public Works (2013)
3. Record drawings and utility plans are also available for purchase from the City (Contact the City's Information Centre by email at InformationCentre@ottawa.ca or by phone at (613) 580-2424 x.44455).
4. The Stormwater Management Criteria, for the subject site, is to be based on the following:
- i. The 2-yr storm event using the IDF information derived from the Meteorological Services of Canada rainfall data, taken from the MacDonald Cartier Airport, collected 1966 to 1997.
 - ii. The pre-development runoff coefficient or a maximum equivalent 'C' of 0.5, whichever is less (§ 8.3.7.3).
 - iii. A calculated time of concentration (Cannot be less than 10 minutes).
 - iv. Flows to the storm sewer in excess of the 2-year storm release rate, up to and including the 100-year storm event, must be detained on site.
 - v. Quality control to be determined by the RVCA.
 - vi. Servicing preferred from Lagan Way
 - vii. No surface ponding within parking areas during the 2-year event.
- Note: There may be area specific SWM Criteria that may apply. Check for any related SWM &/or Sub-watershed studies that may have been completed.
5. Deep Services (Storm, Sanitary & Water Supply)
- i. Provide existing servicing information and the recommended location for the proposed connections. Services should ideally be grouped in a common trench to minimize the number of road cuts.*
 - ii. Connections to trunk sewers and easement sewers are typically not permitted.*

- iii. *Provide information on the monitoring manhole requirements – should be located in an accessible location on private property near the property line (ie. Not in a parking area).*
- iv. *Review provision of a high-level sewer.*
- v. *Provide information on the type of connection permitted*

Sewer connections to be made above the springline of the sewermain as per:

- a. *Std Dwg S11.1 for flexible main sewers – connections made using approved tee or wye fittings.*
 - b. *Std Dwg S11 (For rigid main sewers) – lateral must be less than 50% the diameter of the sewermain,*
 - c. *Std Dwg S11.2 (for rigid main sewers using bell end insert method) – for larger diameter laterals where manufactured inserts are not available; lateral must be less than 50% the diameter of the sewermain,*
 - d. *Connections to manholes permitted when the connection is to rigid main sewers where the lateral exceeds 50% the diameter of the sewermain. – Connect obvert to obvert with the outlet pipe unless pipes are a similar size.*
 - e. *No submerged outlet connections.*
6. Water Boundary condition requests must include the location of the service and the expected loads required by the proposed development. Please provide the following information:
- i. Location of service
 - ii. Type of development and the amount of fire flow required (as per FUS, 1999).
 - iii. Average daily demand: ___ l/s.
 - iv. Maximum daily demand: ___ l/s.
 - v. Maximum hourly daily demand: ___ l/s.

7. Phase 1 ESAs and Phase 2 ESAs must conform to clause 4.8.4 of the Official Plan that requires that development applications conform to Ontario Regulation 153/04.

Should you have any questions or require additional information, please contact me directly at (613) 580-2424, ext. 29686 or by email at Bruce.Bramah@ottawa.ca.

– SITE PLAN APPLICATION – Municipal servicing

Legend:

The letter **S** indicates that the study or plan is required with application submission.

The letter **M** indicates that the study or plan may be required with application submission.

For information on preparing required studies and plans refer to:

<http://ottawa.ca/en/development-application-review-process-0/guide-preparing-studies-and-plans>

S/A	Number of copies	ENGINEERING		S/A	Number of copies
S		1. Site Servicing Plan	2. Assessment of Adequacy of Public Services / Site Servicing Study / Brief	S	
S		3. Grade Control and Drainage Plan	4. Geotechnical Study / Slope Stability Study	S / M	
		5. Composite Utility Plan	6. Groundwater Impact Study		
		7. Servicing Options Report	8. Wellhead Protection Study		
		9. Community Transportation Study and/or Transportation Impact Study / Brief	10. Erosion and Sediment Control Plan / Brief	S	
S		11. Storm water Management Report / Brief	12. Hydro-geological and Terrain Analysis		
M		13. Water main Analysis	14. Noise / Vibration Study	M	
		15. Roadway Modification Design Plan	16. Confederation Line Proximity Study		

– ZONING BYLAW – Municipal servicing

Legend:

The letter **S** indicates that the study or plan is required with application submission.

The letter **M** indicates that the study or plan may be required with application submission.

For information on preparing required studies and plans refer to:

<http://ottawa.ca/en/development-application-review-process-0/guide-preparing-studies-and-plans>

S/A	Number of copies	ENGINEERING		S/A	Number of copies
		1. Site Servicing Plan	2. Assessment of Adequacy of Public Services / Site Servicing Study / Brief	S	
		3. Grade Control and Drainage Plan	4. Geotechnical Study / Slope Stability Study	S / M	
		5. Composite Utility Plan	6. Groundwater Impact Study		
S		7. Servicing Options Report	8. Wellhead Protection Study		
		9. Community Transportation Study and/or Transportation Impact Study / Brief	10. Erosion and Sediment Control Plan / Brief		
		11. Storm water Management Report / Brief	12. Hydro-geological and Terrain Analysis		
		13. Water main Analysis	14. Noise / Vibration Study		
		15. Roadway Modification Design Plan	16. Confederation Line Proximity Study		

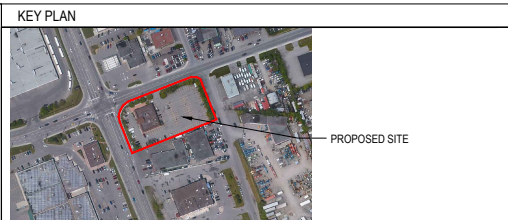
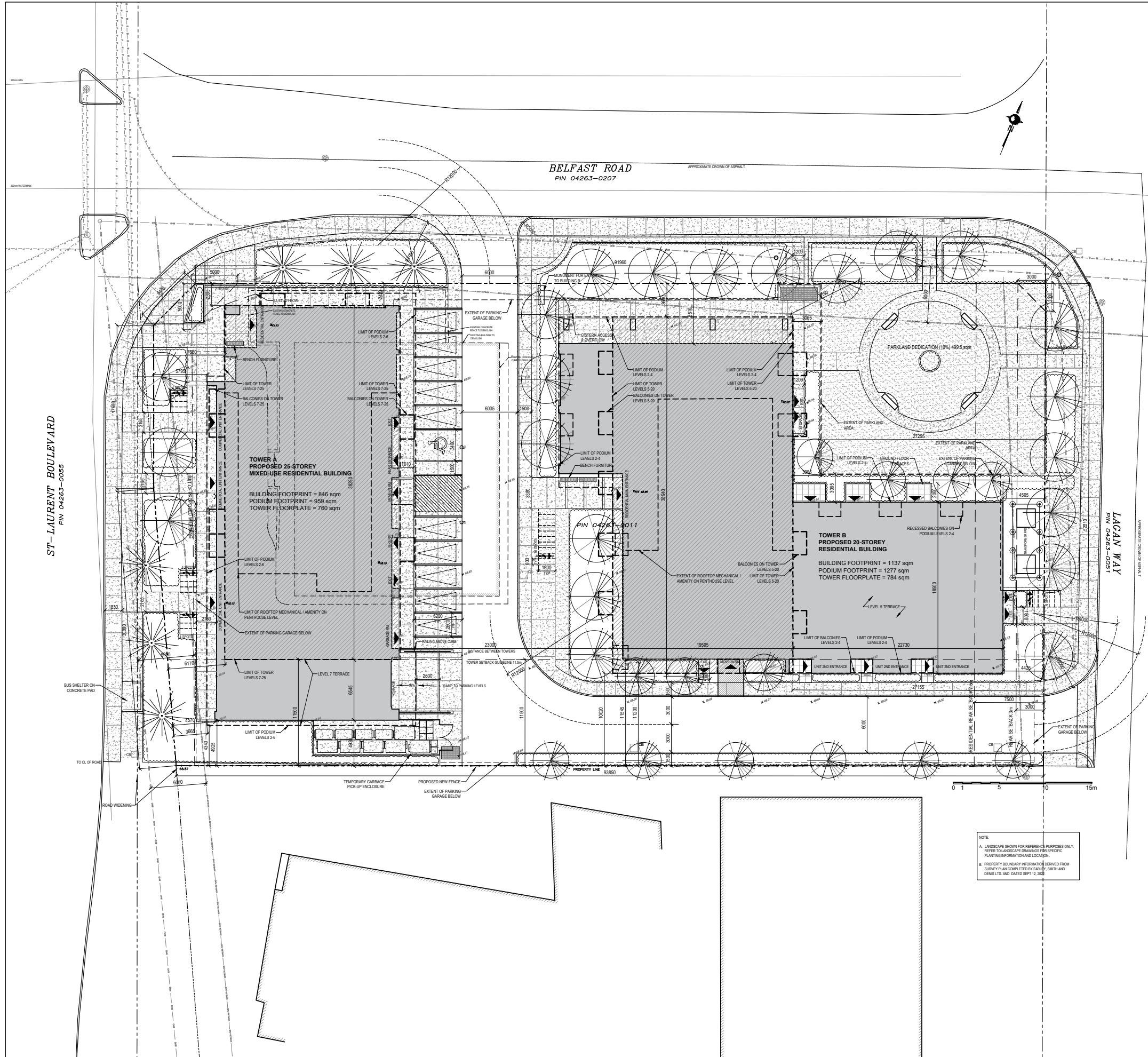

PROPERTY DESCRIPTION

25 & 20 STOREY RESIDENTIAL BUILDINGS
 CITY OF OTTAWA PIN NUMBER: 04263-0011
 MUNICIPAL ADDRESS: 1531 St-Laurent Blvd

SITE INFORMATION

LOT AREA: 4984.1sqm
 LOT FRONTAGE: 198.36m (3 sides)
 LOT DEPTH: 96.43m (E to W) and 52.20m (N to S)

BUILDING INFORMATION

BUILDING FOOTPRINT: TOWER A = 846sqm / TOWER B = 1137 sqm
 TOWER FLOORPLATE: TOWER A = 760 sqm / TOWER B = 784sqm
 GROSS FLOOR AREA (PER CITY DEFINITION): TOWER A = 13261 sqm / TOWER B = 12852 sqm
 PROPOSED USE: MIXED USE RESIDENTIAL, RESIDENTIAL, HIGH-RISE

UNIT BREAKDOWN - TOWER A:

LEVEL	UNITS	UNIT MIX
LEVEL 1:	0 UNITS	0
LEVEL 2:	11 UNITS	7x1BD, 3x2BD, 1x3BD
LEVEL 3-6:	11 UNITS	5x1BD, 4x2BD, 2x3BD
LEVEL 7:	9 UNITS	2xST, 5x1BD, 2x3BD
LEVEL 8-23:	10 UNITS	1xST, 5x1BD, 4x2BD
LEVEL 24-25:	10 UNITS	1xST, 5x1BD, 4x2BD

UNIT BREAKDOWN - TOWER B:

LEVEL	UNITS	UNIT MIX
LEVEL 1:	6 UNITS	4x1BD, 2x 2BD
LEVEL 2-4:	15 UNITS	1x ST, 7x1BD, 6x2BD, 1x3BD
LEVEL 5:	8 UNITS	3x1BD, 3x2BD, 2x3BD
LEVEL 6-10:	9 UNITS	1xST, 4x1BD, 3x2BD, 1X3BD
LEVEL 11-20:	10 UNITS	1XST, 6X1BD, 3X2BD

TOTAL 244 UNITS

ZONING TABLE

CITY OF OTTAWA ZONING BY-LAW No. 2008-250	AM		PROPOSED
	REQUIRED	RESIDENTIAL	
MIXED USE	REQUIRED	RESIDENTIAL	PROPOSED
MINIMUM LOT AREA	no minimum	no minimum	4984.1 sqm
MINIMUM LOT WIDTH	no minimum	no minimum	
MINIMUM FRONT YARD SETBACK (ST-LAURENT)	no minimum	3m	3.665m (actual)
MINIMUM CORNER SIDE YARD SETBACK (BELFAST)	no minimum	no minimum	2.42m (actual)
MINIMUM INTERIOR SIDE YARD SETBACK (SOUTH)	no minimum, not abutting a residential zone	no minimum, not abutting a residential zone	4.34m (actual)
MINIMUM REAR YARD SETBACK (LAGAN WAY)	3 m, abutting a street	7.5m	4.2m (actual)
MAXIMUM BUILDING HEIGHT	30 m, but in no case greater than 9 storeys		Tower A= 82m Tower B= 65.5m
MAXIMUM FLOOR SPACE INDEX	none	none	
HYDRO SETBACK	6m		6m
VEHICLE PARKING REQUIREMENTS (AREA C SCHEDULE 1A)	(mixed use) 1 space/unit 247-12 units= 235 spots req Mixed-Use (Tower A): 1 space/unit Residential (Tower B): 1.2 space/unit Residential Visitor: 0.2/unit Retail: 3.4 spaces/100sqm of gross floor area	(residential) 1.2 space/unit 198-12 units= 212 spots req 5 type A BF 5 type B BF	390 below grade incl. 30 visitor 5 type A BF 5 type B BF 11 Retail at grade, incl. 1 type A BF 401 total
PARKLAND DEDICATION	10% Min. of Land area = 498.4 sqm		499.5 sqm
PARKING AREA AND SURROUNDING LANDSCAPING	15% Min. of Parking lot area (15% of 404 sq.m = 60.6 sq.m) must be provided as perimeter or interior landscaped area. 1.5m landscaped buffer to be provided between the perimeter of the parking lot and a lot line (a driveway may cross the buffer)		Site Landscaping = 1455sqm Counted within property boundaries and excluding the Parkland Dedication
AMENITY AREA REQUIREMENTS	6 square metres per unit (minimum 50% must be communal) 448 units x 6 sqm = 2688 sqm Minimum 1344 sqm communal		COMMUNAL: 1351 sqm PRIVATE BALCONIES: 1470 sqm TOTAL = 2821 sqm
BICYCLE PARKING SPACES	0.5 spaces per unit = 224 spaces		240 INTERIOR SPACES 28 EXTERIOR SPACES

LEGEND

	SOFT LANDSCAPING		FLOOR DRAIN
	PAVERS REFER TO LANDSCAPE		UTILITY POLE
	ASPHALT PAVING		OVERHEAD UTILITY WIRES
	CONCRETE		LIGHT STANDARD
	RIVERSTONE REFER TO LANDSCAPE		DEPRESSED CURB
	EXISTING BUILDING ELEMENT TO BE REMOVED		NEW TREE (REFER TO LANDSCAPE DRAWINGS)
	EXISTING FENCE		EXISTING TREE (REFER TO LANDSCAPE DRAWINGS)
	NEW BOARD FENCE REFER TO LANDSCAPE		NEW PLANTING AREA (REFER TO LANDSCAPE DRAWINGS)
	LOT LINE		EXISTING GROUND ELEVATION (TO DETERMINE EXISTING AVERAGE GRADE)
	SETBACK LINE		NEW GROUND ELEVATION REFER TO CIVIL
	DESIGNATED BUILDING ENTRANCE / EXIT		
	FIRE HYDRANT. REFER TO CIVIL		
	CATCH BASIN		
	MANHOLE		

NOTE: X-E INDICATES EXISTING TO REMAIN

No. Date Engineer / Client

01 2023-06-01 SPC
 02 2023-12-14 COORDINATION
 03 2024-01-16 COORDINATION
 04 2024-07-19 SPC RESPONSE 1
 05 2025-04-29 PLAN ADJUSTMENT REVIEW
 06 2025-05-20 PLAN ADJUSTMENT REVIEW

Engineer / Engineer (Mechanical & Electrical) Mechanical & Electrical

Architect / Architect (Landscape / Landscape) GJA INC.

GJA GINO J. JUELLO | LANDSCAPE ARCHITECT
 1155 BROADVIEW ROAD UNIT #10 OTTAWA ONTARIO K1P 6J2
 TEL: 613-881-5122

Engineer / Engineer (Civil / Civil) egis

755 Palladium Drive
 Ottawa, ON K2V 1C7
 www.egis-group.com

Urban planner / Urbanista FOTENN Planning + Design

420 O'Connor Street
 Ottawa, ON K2P 1R6
 fotenn.com

Client / Client KTS PROPERTIES

101-261 Corling Ave.
 Ottawa, ON K1S 2E1
 KTSProperties.ca

Architect / Architect Collectif des architectes / Architects Collective

figuri

350, Saint-Armande O.
 Montreal QC H4C 1A9
 T: 514 881-5122

252 Anglin Ave
 Ottawa ON K2P 1B9
 T: 613 695-6122

Drawn / Drawn / Copyright

04 2025-04-29

ST-LAURENT DEVELOPMENT

1531 St-Laurent Blvd
 2023-06-01

Site Plan

Designé par / Drawn by No. projet / Project number
 ZK 2303

Verifié par / Verified by No. dessin / Drawing number Révision / Revision
 RC

Echelle / Scale 1:200

Date de création du dessin / Drawing creation date 03/01/2023

A010

APPENDIX C
WATERMAIN CALCULATIONS

1531 St-Laurent Boulevard 1E Pressure Zone

FLEET STREET P.S.

HURDMAN P.S.

BILLINGS BRIDGE P.S.

CARLINGTON HEIGHTS P.S. & RES.

CONROY RD ELEVATED TANK

Site Location

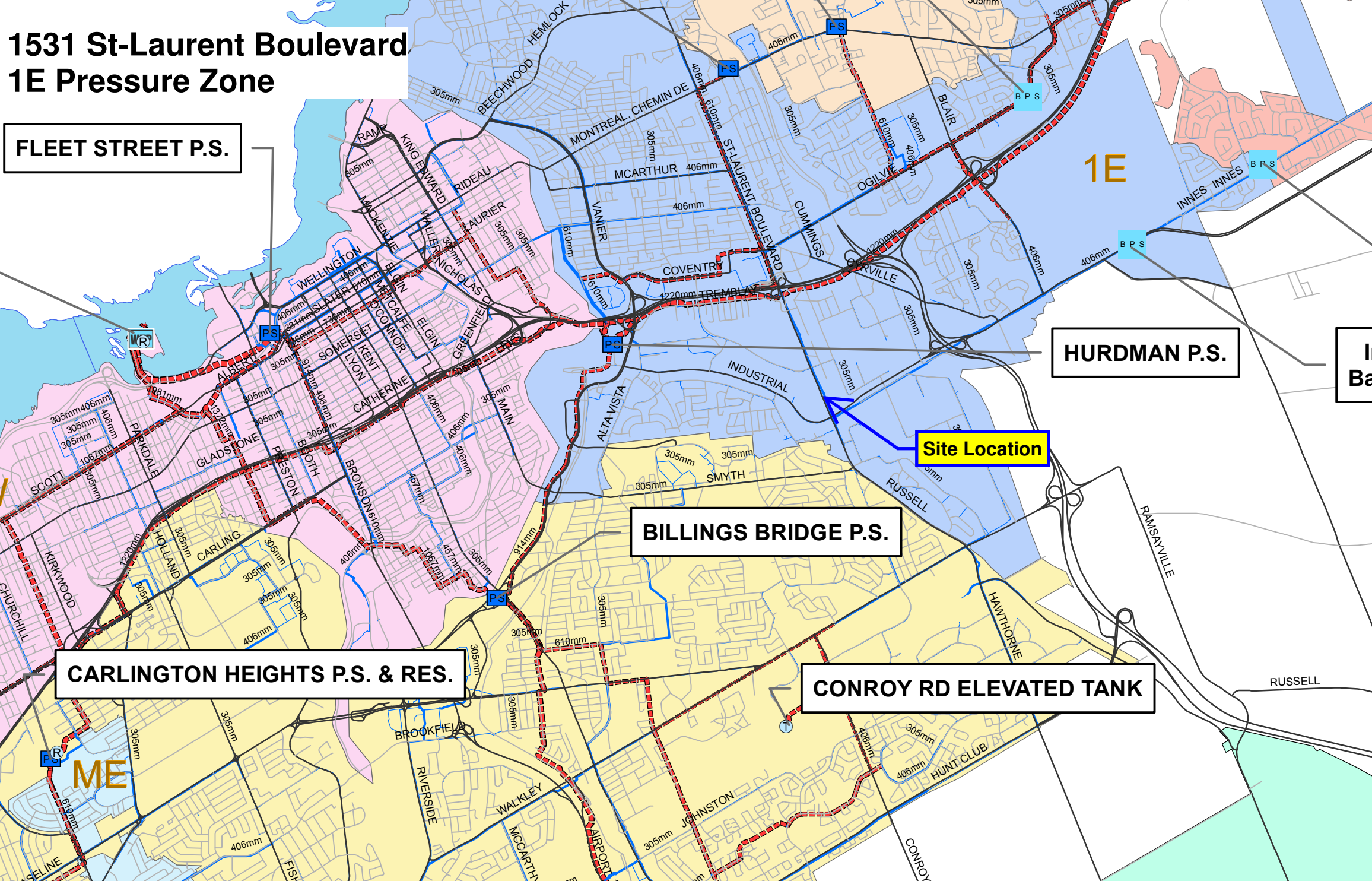



CCO-23-4499 - 1531 St Laurent - Water Demands

Project:	1531 St Laurent
Project No.:	CCO-23-4499
Designed By:	RRR
Checked By:	RDF
Date:	October 22, 2025
Site Area:	0.50 gross ha

<u>Residential</u>	NUMBER OF UNITS	UNIT RATE	
Single Family	homes	3.4	persons/unit
Semi-detached	homes	2.7	persons/unit
Townhouse	homes	2.7	persons/unit
Bachelor Apartment	38 units	1.4	persons/unit
1 Bedroom Apartment	230 units	1.4	persons/unit
2 Bedroom Apartment	159 units	2.1	persons/unit
3 Bedroom Apartment	21 units	3.1	persons/unit
Average Apartment	units	1.8	persons/unit
Total Population	775 persons		
<u>Commercial</u>	601 m2		
<u>Industrial - Light</u>	m2		
<u>Industrial - Heavy</u>	m2		

AVERAGE DAILY DEMAND

DEMAND TYPE	AMOUNT	UNITS	
Residential	280	L/c/d	
Industrial - Light	35,000	L/gross ha/d	
Industrial - Heavy	55,000	L/gross ha/d	
Shopping Centres	2,500	L/(1000m ² /d)	
Hospital	900	L/(bed/day)	
Schools	70	L/(Student/d)	
Trailer Park with no Hook-Ups	340	L/(space/d)	
Trailer Park with Hook-Ups	800	L/(space/d)	
Campgrounds	225	L/(campsite/d)	
Mobile Home Parks	1,000	L/(Space/d)	
Motels	150	L/(bed-space/d)	
Hotels	225	L/(bed-space/d)	
Tourist Commercial	28,000	L/gross ha/d	
Other Commercial	28,000	L/gross ha/d	
AVERAGE DAILY DEMAND	Residential	2.51	L/s
	Commercial/Industrial/ Institutional	0.02	L/s

MAXIMUM DAILY DEMAND

DEMAND TYPE	AMOUNT		UNITS
Residential	2.5	x avg. day	L/c/d
Industrial	1.5	x avg. day	L/gross ha/d
Commercial	1.5	x avg. day	L/gross ha/d
Institutional	1.5	x avg. day	L/gross ha/d
MAXIMUM DAILY DEMAND	Residential	6.28	L/s
	Commercial/Industrial/ Institutional	0.03	L/s

MAXIMUM HOUR DEMAND

DEMAND TYPE	AMOUNT		UNITS
Residential	2.2	x max. day	L/c/d
Industrial	1.8	x max. day	L/gross ha/d
Commercial	1.8	x max. day	L/gross ha/d
Institutional	1.8	x max. day	L/gross ha/d
MAXIMUM HOUR DEMAND	Residential	13.81	L/s
	Commercial/Industrial/ Institutional	0.05	L/s

WATER DEMAND DESIGN FLOWS PER UNIT COUNT

CITY OF OTTAWA - WATER DISTRIBUTION GUIDELINES, JULY 2010

AVERAGE DAILY DEMAND	2.53	L/s
MAXIMUM DAILY DEMAND	6.31	L/s
MAXIMUM HOUR DEMAND	13.87	L/s

CCO-23-4499 - 1531 St Laurent - Fire Underwriters Survey - 25 Storey Building

Project: 1531 St Laurent
 Project No.: CCO-23-4499
 Designed By: RRR
 Checked By: RDF
 Date: October 20, 2025

From the Fire Underwriters Survey (2020)

From Part II – Guide for Determination of Required Fire Flow Copyright I.S.O.:
 City of Ottawa Technical Bulletin ISTB-2018-02 Applied Where Applicable

A. BASE REQUIREMENT (Rounded to the nearest 1000 L/min)

F = 220 x C x √A Where:

F = Required fire flow in liters per minute

C = Coefficient related to the type of construction.

A = The total effective floor area in square meters (two largest adjoining floor areas plus 50% of all floors immediately above them up to a maximum of eight) in the building being considered.

Construction Type Non-Combustible Construction

C 0.8

Floor Level	Area (m ²)	Area Applied (m ²)
L2	944	944
L3	959	959
L4	959	480
L5	959	480
L6	959	480
L7	718	359
L8	713	357
L9	713	357

Total Floor Area (per the 2020 FUS Page 20 - Total Effective Area) 4,414 m²

*Unprotected Vertical Openings

Calculated Fire Flow

11,692.4 L/min

12,000.0 L/min

B. REDUCTION FOR OCCUPANCY TYPE (No Rounding)

From Page 24 of the Fire Underwriters Survey:
 Non-Combustible

-25%

Fire Flow

9,000.0 L/min

C. REDUCTION FOR SPRINKLER TYPE (No Rounding)

Standard Water Supply Sprinklered

-40%

Reduction

-3,600.0 L/min

D. INCREASE FOR EXPOSURE (No Rounding)

	Separation Distance (m)	Cons.of Exposed Wall	Length Exposed Adjacent Wall (m)	Height (Stories)	Length-Height Factor	
Exposure 1	Over 30 m	Ordinary - Mass Timber (Unprotected)	20	1	20.0	0%
Exposure 2	10.1 to 20	Fire Resistive - Non Combustible (Protected Openings)	35	20	700.0	3%
Exposure 3	10.1 to 20	Ordinary - Mass Timber (Unprotected)	30	1	30.0	6%
Exposure 4	Over 30 m	Ordinary - Mass Timber (Unprotected)	26	1	26.0	0%
					% Increase*	9%

Increase*

810.0 L/min

E. Total Fire Flow (Rounded to the Nearest 1000 L/min)

Fire Flow

6,210.0 L/min

Fire Flow Required**

6,000.0 L/min

*In accordance with Part II, Section 4, the Increase for separation distance is not to exceed 75%

**In accordance with Section 4 the Fire flow is not to exceed 45,000 L/min or be less than 2,000 L/min



CCO-23-4499 - 1531 St Laurent - Fire Underwriters Survey - 20 Storey Building

Project: 1531 St Laurent
 Project No.: CCO-23-4499
 Designed By: RRR
 Checked By: RDF
 Date: October 20, 2025

From the Fire Underwriters Survey (2020)

From Part II – Guide for Determination of Required Fire Flow Copyright I.S.O.:
 City of Ottawa Technical Bulletin ISTB-2018-02 Applied Where Applicable

A. BASE REQUIREMENT (Rounded to the nearest 1000 L/min)

F = 220 x C x √A Where:

F = Required fire flow in liters per minute

C = Coefficient related to the type of construction.

A = The total effective floor area in square meters (two largest adjoining floor areas plus 50% of all floors immediately above them up to a maximum of eight) in the building being considered.

Construction Type **Non-Combustible Construction**

C 0.8

Floor Level	Area (m ²)	Area Applied (m ²)
L2	1225	1225
L3	1225	1225
L4	1225	612.5
L5	750	375
L6	750	375
L7	750	375
L8	750	375
L9	750	375

Total Floor Area (per the 2020 FUS Page 20 - Total Effective Area) **4,938 m²**

**Unprotected Vertical Openings*

Calculated Fire Flow	12,367.1 L/min
	12,000.0 L/min

B. REDUCTION FOR OCCUPANCY TYPE (No Rounding)

From Page 24 of the Fire Underwriters Survey:
 Non-Combustible

-25%

Fire Flow	9,000.0 L/min
-----------	---------------

C. REDUCTION FOR SPRINKLER TYPE (No Rounding)

Standard Water Supply Sprinklered

-40%

Reduction	-3,600.0 L/min
-----------	----------------

D. INCREASE FOR EXPOSURE (No Rounding)

	Separation Distance (m)	Cons.of Exposed Wall	Length Exposed Adjacent Wall (m)	Height (Stories)	Length-Height Factor	
Exposure 1	Over 30 m	Ordinary - Mass Timber (Unprotected)	20	1	20.0	0%
Exposure 2	Over 30 m	Ordinary - Mass Timber (Unprotected)	23	2	46.0	0%
Exposure 3	10.1 to 20	Ordinary - Mass Timber (Unprotected)	22	1	22.0	6%
Exposure 4	10.1 to 20	Fire Resistive - Non Combustible (Protected Openings)	45	25	1125.0	0%
					% Increase*	6%

Increase*	540.0 L/min
-----------	-------------

E. Total Fire Flow (Rounded to the Nearest 1000 L/min)

Fire Flow	5,940.0 L/min
Fire Flow Required**	6,000.0 L/min

*In accordance with Part II, Section 4, the Increase for separation distance is not to exceed 75%

**In accordance with Section 4 the Fire flow is not to exceed 45,000 L/min or be less than 2,000 L/min

McINTOSH PERRY

000-23-4499 - 1531 St Laurent - Boundary Condition Unit Conversion

Project: 1531 St Laurent
Project No.: 000-23-4499
Designed By: RFR
Checked By: RDF
Date: February 5, 2024

Boundary Conditions Unit Conversion

BELFAST ROAD

Scenario	Height (m)	Elevation (m)	m H ₂ O	PSI	kPa
Avg. DD	118.2	66.02	52.2	74.2	511.9
Fire Flow (133.3 L/s)	112.4	66.02	46.4	66.0	455.0
Peak Hour	110.0	66.02	44.0	62.6	431.4

1531 St-Laurent FUS Hydrant Coverage Figure

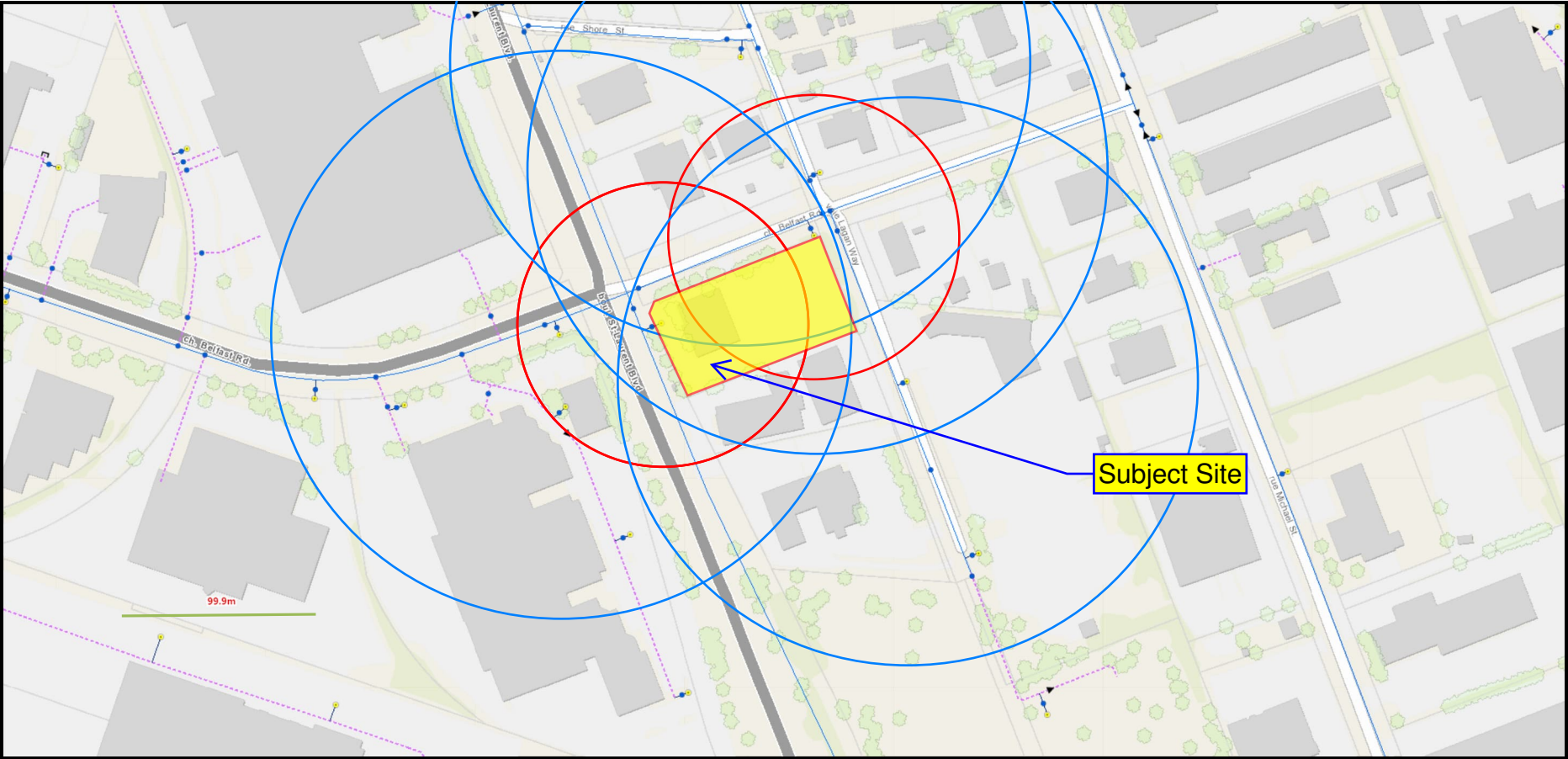

Hydrants Within 75m: 2

Hydrants Within 150m: 4

Ryan Robineau

From: Adams, Reed <reed.adams@ottawa.ca>
Sent: February 5, 2024 10:28 AM
To: Alison Gosling
Cc: Ryan Robineau
Subject: RE: 1531 St.Laurent Boundary Condition Request
Attachments: 1531 St-Laurent Boulevard REVISED January 2024.pdf

Hi Alison,

Here they are:

The following are boundary conditions, HGL, for hydraulic analysis at 1531 St-Laurent Boulevard (zone 1E) assumed to be connected to the 305 mm watermain (dual connection with a separation valve in between) on Belfast Road (see attached PDF for location).

Min HGL: 110.0 m
Max HGL: 118.2 m
Max Day + Fire Flow (133.3 L/s): 112.4 m

These are for current conditions and are based on computer model simulation.

Disclaimer: The boundary condition information is based on current operation of the city water distribution system. The computer model simulation is based on the best information available at the time. The operation of the water distribution system can change on a regular basis, resulting in a variation in boundary conditions. The physical properties of watermains deteriorate over time, as such must be assumed in the absence of actual field test data. The variation in physical watermain properties can therefore alter the results of the computer model simulation.

Thanks,

Reed

From: Alison Gosling <a.gosling@mcintoshperry.com>
Sent: February 05, 2024 8:58 AM
To: Adams, Reed <reed.adams@ottawa.ca>
Cc: Ryan Robineau <r.robineau@mcintoshperry.com>
Subject: RE: 1531 St.Laurent Boundary Condition Request

CAUTION: This email originated from an External Sender. Please do not click links or open attachments unless you recognize the source.

ATTENTION : Ce courriel provient d'un expéditeur externe. Ne cliquez sur aucun lien et n'ouvrez pas de pièce jointe, excepté si vous connaissez l'expéditeur.

Good morning Reed,

Have you heard back about the boundary conditions? We are working on an updated servicing design and are hoping to include the new BC results.

APPENDIX D
SANITARY CALCULATIONS

1531 St-Laurent Blvd Trunk Sewer Figure Innes Road Trunk

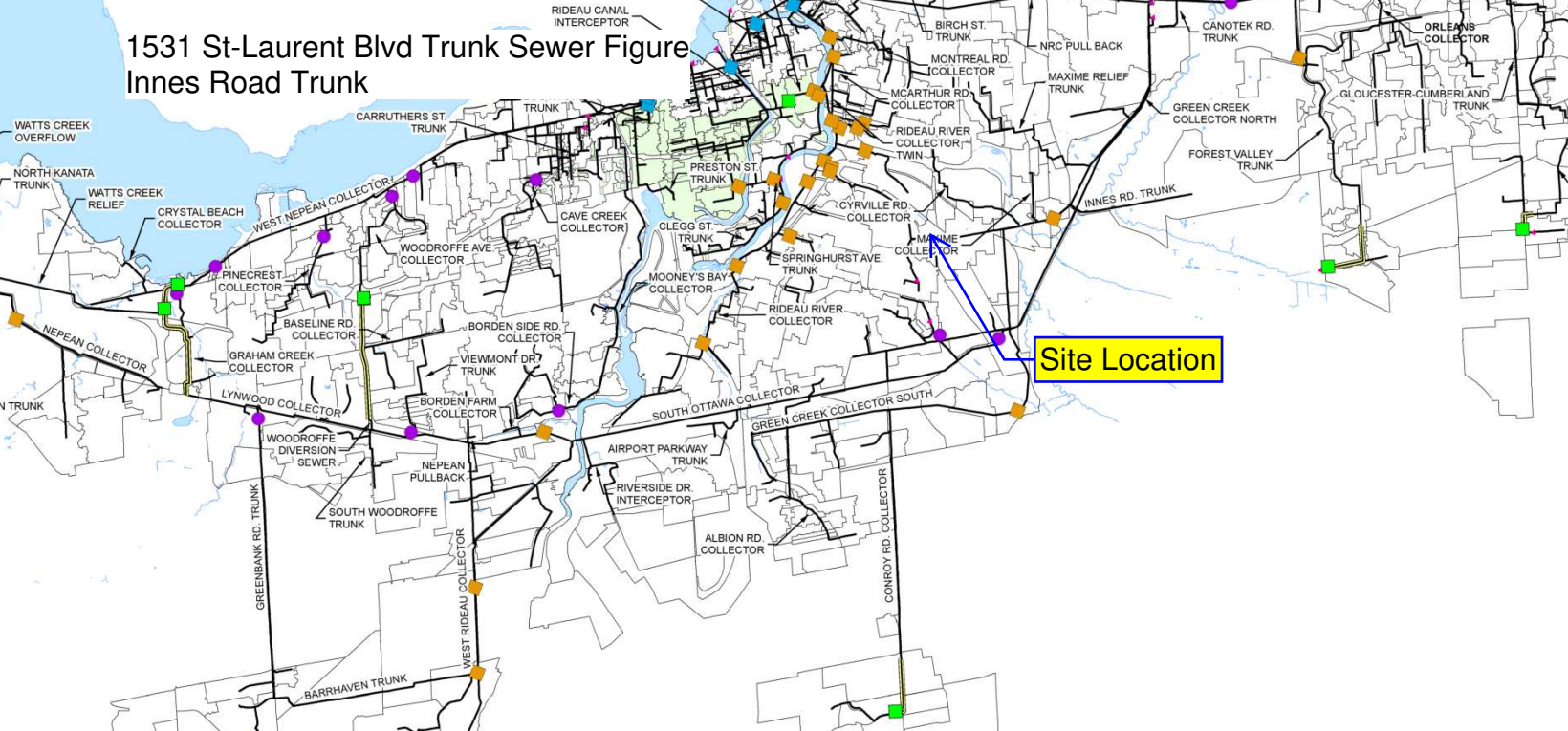



CCO-23-4499 - 1531 St Laurent - Sanitary Demands

Project:	1531 St Laurent		
Project No.:	CCO-23-4499		
Designed By:	RRR		
Checked By:	RDF		
Date:	October 22, 2025		
Site Area	0.50	Gross ha	
Bachelor	38		1.40 Persons per unit
1 Bedroom	230		1.40 Persons per unit
2 Bedroom	159		2.10 Persons per unit
3 Bedroom	21		3.10 Persons per unit
Total Population	775	Persons	
Commercial Area	601	m ²	
Amenity Space	1351	m ²	

DESIGN PARAMETERS

Institutional/Commercial Peaking Factor	1	*Check technical bulleting (Either use 1.0 or 1.5)
Residential Peaking Factor	3.29	* Using Harmon Formula = $1+(14/(4+P^{0.5}))$ *0.8 where P = population in thousands, Harmon's Correction Factor = 0.8
Mannings coefficient (n)	0.013	
Demand (per capita)	280	L/day
Infiltration allowance	0.33	L/s/Ha

EXTRANEIOUS FLOW ALLOWANCES

Infiltration / Inflow	Flow (L/s)
Dry	0.02
Wet	0.14
Total	0.16

AVERAGE DAILY DEMAND

DEMAND TYPE	AMOUNT	UNITS	POPULATION / AREA	Flow (L/s)
Residential	280	L/c/d	775	2.51
Industrial - Light**	35,000	L/gross ha/d		0
Industrial - Heavy**	55,000	L/gross ha/d		0
Commercial / Amenity	2,800	L/(1000m ² /d)	1952	0.06
Hospital	900	L/(bed/day)		0
Schools	70	L/(Student/d)		0
Trailer Parks no Hook-Ups	340	L/(space/d)		0
Trailer Park with Hook-Ups	800	L/(space/d)		0
Campgrounds	225	L/(campsite/d)		0
Mobile Home Parks	1,000	L/(Space/d)		0
Motels	150	L/(bed-space/d)		0
Hotels	225	L/(bed-space/d)		0
Office	75	L/7.0m ² /d		0
Tourist Commercial	28,000	L/gross ha/d		0
Other Commercial	28,000	L/gross ha/d		0



AVERAGE RESIDENTIAL FLOW	2.51	L/s
PEAK RESIDENTIAL FLOW	8.28	L/s
AVERAGE ICI FLOW	0.06	L/s
PEAK INSTITUTIONAL/COMMERCIAL FLOW	0.06	L/s
PEAK INDUSTRIAL FLOW	0.00	L/s
TOTAL PEAK ICI FLOW	0.06	L/s

TOTAL SANITARY DEMAND

TOTAL ESTIMATED AVERAGE DRY WEATHER FLOW	2.60	L/s
TOTAL ESTIMATED PEAK DRY WEATHER FLOW	8.36	L/s
TOTAL ESTIMATED PEAK WET WEATHER FLOW	8.50	L/s

SANITARY SEWER DESIGN SHEET

PROJECT: CCO-23-4499
 LOCATION: 1531 St Laurent



LOCATION			RESIDENTIAL									ICI AREAS						INFILTRATION ALLOWANCE			FLOW		SEWER DATA						
1	2	3	5	6	7	8	9	10	11	12	13	14	15	16	17	18	19	20	21	22	23	24	25	26	27	28	29	30	31
STREET	AREA ID	FROM MH	UNIT TYPES				AREA (ha)	POPULATION		PEAK FACTOR	PEAK FLOW (L/s)	AREA (ha)						PEAK FLOW (L/s)	AREA (ha)		FLOW (L/s)	DESIGN FLOW (L/s)	CAPACITY (L/s)	LENGTH (m)	DIA (mm)	SLOPE (%)	VELOCITY (full) (m/s)	AVAILABLE CAPACITY	
			Bac/1-Bed	2-Bed	3-Bed	APT		IND	CUM			INSTITUTIONAL		COMMERCIAL		INDUSTRIAL			IND	CUM								IND	CUM
Belfast Road	BLDG	MH1A	268	159	21		0.50	775.0	775.0	3.29	8.28	0.00	0.00	0.18	0.18		0.00	0.06	0.50	0.50	0.16	8.50	34.22	1.12	200	1.00	1.055	25.71	75.15
	MH1A	Ex. Sewer									8.28		0.00		0.18		0.00	0.06	0.00	0.50	0.16	8.50	34.22	13.97	200	1.00	1.055	25.71	75.15
Design Parameters:			Notes:									Designed:						No.		Revision						Date			
Residential			ICI Areas									RRR																	
1-BED 1.4 p/p/u			1. Mannings coefficient (n) = 0.013									RDF																	
2-Bed 2.1 p/p/u			2. Demand (per capita): 280 L/day									Project No.: CCO-23-4499																	
3-Bed 3.1 p/p/u			3. Infiltration allowance: 0.33 L/s/Ha																										
Other 60 p/p/Ha			4. Residential Peaking Factor: Harmon Formula = $1+(14/(4+P^{0.5}))*0.8$ where P = population in thousands																										
																										Sheet No: 1 of 1			

APPENDIX E
PRE-DEVELOPMENT DRAINAGE PLAN

APPENDIX F
POST-DEVELOPMENT DRAINAGE PLAN

APPENDIX G
STORMWATER MANAGEMENT CALCULATIONS

McINTOSH PERRY

CO-22-4499 - 1531 St. Laurent - SWM Calculations

1 of 3

Tc (min)	Intensity (mm/hr)			
	2-Year	5-Year	100-Year	
10	76.8	104.2	178.6	PRE-DEVELOPMENT
10	76.8	104.2	178.6	POST-DEVELOPMENT

C-Values	
Impervious	0.90
Gravel	0.60
Pervious	0.20

Pre-Development Runoff Coefficient

Drainage Area	Impervious Area (m ²)	Gravel (m ²)	Pervious Area (m ²)	Average C (5-year)	Average C (100-year)
A1	4,425	0	60	0.89	0.99

Pre-Development Runoff Calculations

Drainage Area	Area (ha)	C 5-Year	C 100-Year	Tc (min)	Q (L/s)		
					2-Year	5-Year	100-Year
A1	0.448	0.89	0.99	10	85.28	115.69	220.38
Total	0.45				85.28	115.69	220.38

Post-Development Runoff Coefficient

Drainage Area	Impervious Area (m ²)	Gravel (m ²)	Pervious Area (m ²)	Average C (5-year)	Average C (100-year)
B1	3,502	0	353	0.84	0.93
B2	317	0	312	0.55	0.63

Post-Development Runoff Calculations

Drainage Area	Area (ha)	C 5-Year	C 100-Year	Tc (min)	Q (L/s)		
					5-Year	100-Year	
B1	0.39	0.84	0.93	10	93.35	178.24	Restricted
B2	0.06	0.55	0.63	10	10.08	19.62	Unrestricted
Total	0.45				103.43	197.86	

Required Restricted Flow

Drainage Area	Area (ha)	C 2-Year	Tc (min)	Q (L/s)
				2-Year
A1	0.45	0.50	10	47.88

Post-Development Restricted Runoff Calculations

Drainage Area	Unrestricted Flow (L/S)		Restricted Flow (L/S)		Storage Required (m ³)		Storage Provided (m ³)	
	5-year	100-Year	5-Year	100-Year	5-Year	100-Year	5-Year	100-Year
B1	93.35	178.24	14.35	27.34	61.1	115.9	115.9	115.9
B2	10.08	19.62	10.08	19.62				
Total	103.43	197.86	24.42	46.96	61.1	115.9	115.9	115.9

McINTOSH PERRY

CO-22-4499 - 1531 St. Laurent - SWM Calculations

2 of 3

Storage Requirements for Area B1

5-Year Storm Event

Tc (min)	I (mm/hr)	Runoff (L/s) B1	Allowable Outflow (L/s)	Runoff to be Stored (L/s)	Storage Required (m ³)
10	104.2	93.36	14.35	79.01	47.41
20	70.3	62.98	14.35	48.64	58.37
30	53.9	48.29	14.35	33.95	61.10
40	44.2	39.60	14.35	25.26	60.61
50	37.7	33.78	14.35	19.43	58.30

Maximum Storage Required 5-year = 61 m³

100-Year Storm Event

Tc (min)	I (mm/hr)	Runoff (L/s) B1	Allowable Outflow (L/s)	Runoff to be Stored (L/s)	Storage Required (m ³)
10	178.6	178.28	27.34	150.94	90.56
20	120.0	119.78	27.34	92.44	110.93
30	91.9	91.74	27.34	64.40	115.91
40	75.1	74.97	27.34	47.63	114.30
50	64.0	63.89	27.34	36.55	109.64
60	55.9	55.80	27.34	28.46	102.46
70	49.8	49.71	27.34	22.37	93.96
80	45.0	44.92	27.34	17.58	84.38
90	41.1	41.03	27.34	13.69	73.91
100	37.9	37.83	27.34	10.49	62.95

Maximum Storage Required 100-year = 116 m³

5-Year Storm Event Storage Summary

Storage Available (m ³) = 115.9	* Provided by on-site cistern
Storage Required (m ³) = 61.1	

100-Year Storm Event Storage Summary

Storage Available (m ³) = 115.9	* Provided by on-site cistern
Storage Required (m ³) = 115.9	

McINTOSH PERRY

CO-22-4499 - 1531 St. Laurent - SWM Calculations

3 of 3

Time of Concentration Pre-Development

Drainage Area ID	Sheet Flow Distance (m)	Slope of Land (%)	Tc (min) (5-Year)	Tc (min) (100-Year)
A1	112	0.71	8	4

Therefore, a Tc of 10 can be used

$$T_c = (3.26(1.1-c)L^{0.5}/S^{0.33})$$

c = Balanced Runoff Coefficient

L = Length of drainage area

S = Average slope of watershed

STORM SEWER DESIGN SHEET

PROJECT: COO-23-4499
 LOCATION: 1531 St Laurent

McINTOSH PERRY

LOCATION				CONTRIBUTING AREA (ha)				RATIONAL DESIGN FLOW											SEWER DATA								
1	2	3	4	5	6	7	8	9	10	11	12	13	14	15	16	17	18	19	20	21	22	23	24	25	26	27	28
STREET	AREA ID	FROM	TO	C-VALUE	AREA	INDIV	CUMUL	INLET	TIME	TOTAL	i (5)	i (10)	i (100)	5yr PEAK	10yr PEAK	100yr PEAK	FIXED	DESIGN	CAPACITY	LENGTH	PIPE SIZE (mm)			SLOPE	VELOCITY	AVAIL CAP (5yr)	
		MH	MH			AC	AC														(min)	(min)	(mm/hr)			(mm/hr)	(mm/hr)
Belfast Road	B1	BLDG	OGSI	0.84	0.39	0.32	0.32	10.00	0.01	10.01	104.19	122.14	178.56	94.86	109.43	159.98		94.86	100.88	1.04	300			1.00	1.383	6.02	5.97%
		OGSI	EX. Sewer			0.00	0.32	10.01	0.28	10.30	104.13	122.06	178.44	94.86	109.36	159.87		94.86	100.88	23.58	300			1.00	1.383	6.02	5.97%
Definitions: Q = 2.78QA, where: Q = Peak Flow in Litres per Second (L/s) A = Area in Hectares (ha) i = Rainfall intensity in millimeters per hour (mm/hr) [i = 998.071 / (TC+6.053)^0.814] 5 YEAR [i = 1174.184 / (TC+6.014)^0.816] 10 YEAR [i = 1735.688 / (TC+6.014)^0.820] 100 YEAR				Notes: 1. Mannings coefficient (n) = 0.013				Designed: RFR Checked: RDF Project No.: COO-23-4499				No. 1.				Revision				Date							
																			Date:				Sheet No: 1 of 1				

Stormceptor® EF Sizing Report

Imbrium® Systems

ESTIMATED NET ANNUAL SEDIMENT (TSS) LOAD REDUCTION

02/03/2024

Province:	Ontario
City:	Ottawa
Nearest Rainfall Station:	OTTAWA CDA RCS
Climate Station Id:	6105978
Years of Rainfall Data:	20

Project Name:	1531 St. Laurent
Project Number:	CCO-4499
Designer Name:	Ryan Robineau
Designer Company:	Egis in Canada Ltd.
Designer Email:	r.robineau@mcintoshperry.com
Designer Phone:	613-714-6611
EOR Name:	
EOR Company:	
EOR Email:	
EOR Phone:	

Site Name:

Drainage Area (ha): 0.39

Runoff Coefficient 'c': 0.93

Particle Size Distribution: Fine

Target TSS Removal (%): 80.0

Required Water Quality Runoff Volume Capture (%):	90.00
Estimated Water Quality Flow Rate (L/s):	11.71
Oil / Fuel Spill Risk Site?	Yes
Upstream Flow Control?	Yes
Upstream Orifice Control Flow Rate to Stormceptor (L/s):	27.34
Peak Conveyance (maximum) Flow Rate (L/s):	
Influent TSS Concentration (mg/L):	100
Estimated Average Annual Sediment Load (kg/yr):	231
Estimated Average Annual Sediment Volume (L/yr):	188

Net Annual Sediment (TSS) Load Reduction Sizing Summary	
Stormceptor Model	TSS Removal Provided (%)
EFO4	87
EFO6	94
EFO8	98
EFO10	99
EFO12	100

Recommended Stormceptor EFO Model: EFO4

Estimated Net Annual Sediment (TSS) Load Reduction (%): 87

Water Quality Runoff Volume Capture (%): > 90



Stormceptor® EF Sizing Report

THIRD-PARTY TESTING AND VERIFICATION

► **Stormceptor® EF and Stormceptor® EFO** are the latest evolutions in the Stormceptor® oil-grit separator (OGS) technology series, and are designed to remove a wide variety of pollutants from stormwater and snowmelt runoff. These technologies have been third-party tested in accordance with the Canadian ETV **Procedure for Laboratory Testing of Oil-Grit Separators** and performance has been third-party verified in accordance with the **ISO 14034 Environmental Technology Verification (ETV)** protocol.

PERFORMANCE

► **Stormceptor® EF and EFO** remove stormwater pollutants through gravity separation and floatation, and feature a patent-pending design that generates positive removal of total suspended solids (TSS) throughout each storm event, including high-intensity storms. Captured pollutants include sediment, free oils, and sediment-bound pollutants such as nutrients, heavy metals, and petroleum hydrocarbons. Stormceptor is sized to remove a high level of TSS from the frequent rainfall events that contribute the vast majority of annual runoff volume and pollutant load. The technology incorporates an internal bypass to convey excessive stormwater flows from high-intensity storms through the device without resuspension and washout (scour) of previously captured pollutants. Proper routine maintenance ensures high pollutant removal performance and protection of downstream waterways.

PARTICLE SIZE DISTRIBUTION (PSD)

► The **Canadian ETV PSD** shown in the table below was used, or in part, for this sizing. This is the identical PSD that is referenced in the Canadian ETV **Procedure for Laboratory Testing of Oil-Grit Separators** for both sediment removal testing and scour testing. The Canadian ETV PSD contains a wide range of particle sizes in the sand and silt fractions, and is considered reasonably representative of the particle size fractions found in typical urban stormwater runoff.

Particle Size (µm)	Percent Less Than	Particle Size Fraction (µm)	Percent
1000	100	500-1000	5
500	95	250-500	5
250	90	150-250	15
150	75	100-150	15
100	60	75-100	10
75	50	50-75	5
50	45	20-50	10
20	35	8-20	15
8	20	5-8	10
5	10	2-5	5
2	5	<2	5

Stormceptor® EF Sizing Report

Upstream Flow Controlled Results

Rainfall Intensity (mm / hr)	Percent Rainfall Volume (%)	Cumulative Rainfall Volume (%)	Flow Rate (L/s)	Flow Rate (L/min)	Surface Loading Rate (L/min/m ²)	Removal Efficiency (%)	Incremental Removal (%)	Cumulative Removal (%)
0.50	8.6	8.6	0.50	30.0	25.0	100	8.6	8.6
1.00	20.3	29.0	1.01	60.0	50.0	100	20.3	29.0
2.00	16.2	45.2	2.02	121.0	101.0	96	15.6	44.5
3.00	12.0	57.2	3.02	181.0	151.0	89	10.7	55.3
4.00	8.4	65.6	4.03	242.0	202.0	83	7.0	62.3
5.00	5.9	71.6	5.04	302.0	252.0	81	4.8	67.1
6.00	4.6	76.2	6.05	363.0	302.0	78	3.6	70.7
7.00	3.1	79.3	7.06	423.0	353.0	76	2.3	73.0
8.00	2.7	82.0	8.07	484.0	403.0	74	2.0	75.1
9.00	3.3	85.3	9.07	544.0	454.0	72	2.4	77.4
10.00	2.3	87.6	10.08	605.0	504.0	69	1.6	79.0
11.00	1.6	89.2	11.09	665.0	555.0	67	1.0	80.1
12.00	1.3	90.5	12.10	726.0	605.0	65	0.9	80.9
13.00	1.7	92.2	13.11	786.0	655.0	64	1.1	82.0
14.00	1.2	93.5	14.12	847.0	706.0	64	0.8	82.8
15.00	1.2	94.6	15.12	907.0	756.0	63	0.7	83.6
16.00	0.7	95.3	16.13	968.0	807.0	63	0.4	84.0
17.00	0.7	96.1	17.14	1028.0	857.0	63	0.5	84.5
18.00	0.4	96.5	18.15	1089.0	907.0	62	0.2	84.7
19.00	0.4	96.9	19.16	1149.0	958.0	62	0.3	85.0
20.00	0.2	97.1	20.17	1210.0	1008.0	62	0.1	85.1
21.00	0.5	97.5	21.17	1270.0	1059.0	60	0.3	85.4
22.00	0.2	97.8	22.18	1331.0	1109.0	59	0.1	85.5
23.00	1.0	98.8	23.19	1391.0	1160.0	58	0.6	86.1
24.00	0.3	99.1	24.20	1452.0	1210.0	57	0.2	86.3
25.00	0.9	100.0	25.21	1512.0	1260.0	56	0.5	86.8
30.00	0.0	100.0	27.00	1620.0	1350.0	53	0.0	86.8
35.00	0.0	100.0	27.00	1620.0	1350.0	53	0.0	86.8
40.00	0.0	100.0	27.00	1620.0	1350.0	53	0.0	86.8
45.00	0.0	100.0	27.00	1620.0	1350.0	53	0.0	86.8
Estimated Net Annual Sediment (TSS) Load Reduction =								87 %

Climate Station ID: 6105978 Years of Rainfall Data: 20

Stormceptor® EF Sizing Report

RAINFALL DATA FROM OTTAWA CDA RCS RAINFALL STATION

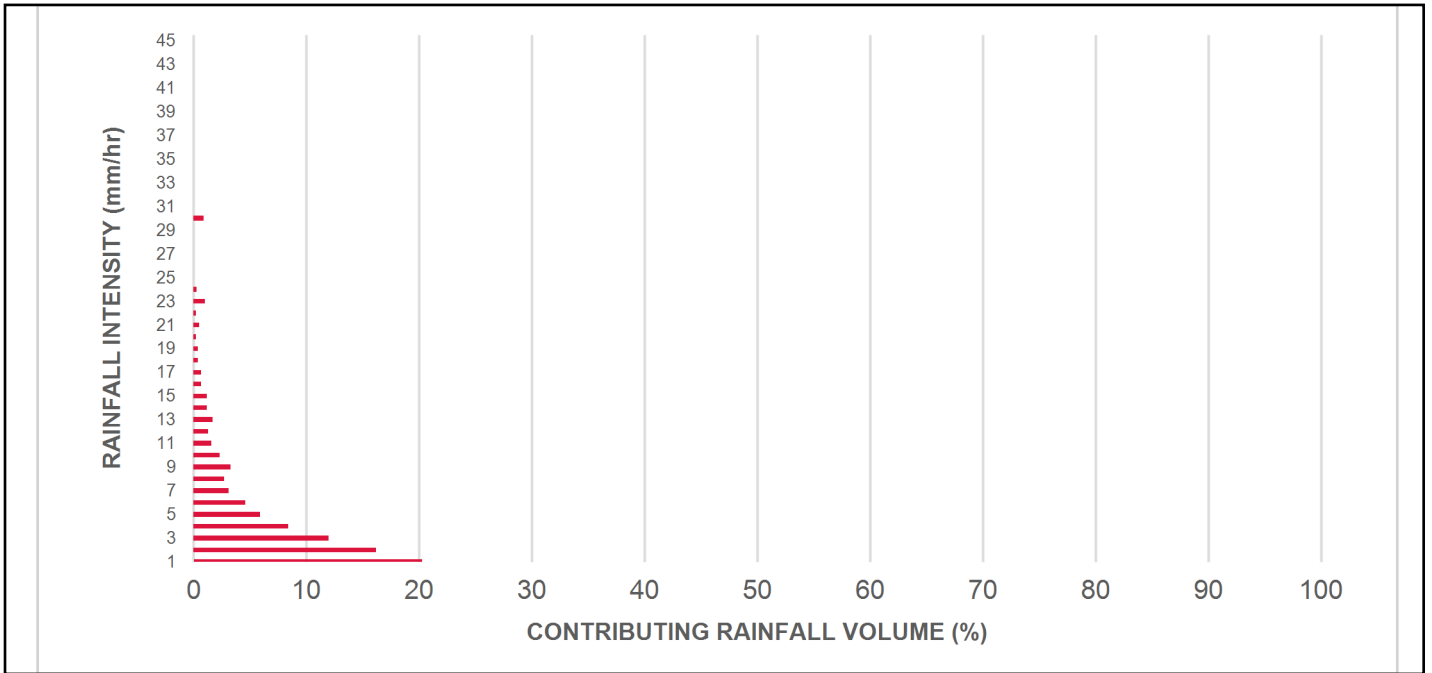

INCREMENTAL AND CUMULATIVE TSS REMOVAL FOR THE RECOMMENDED STORMCEPTOR® MODEL

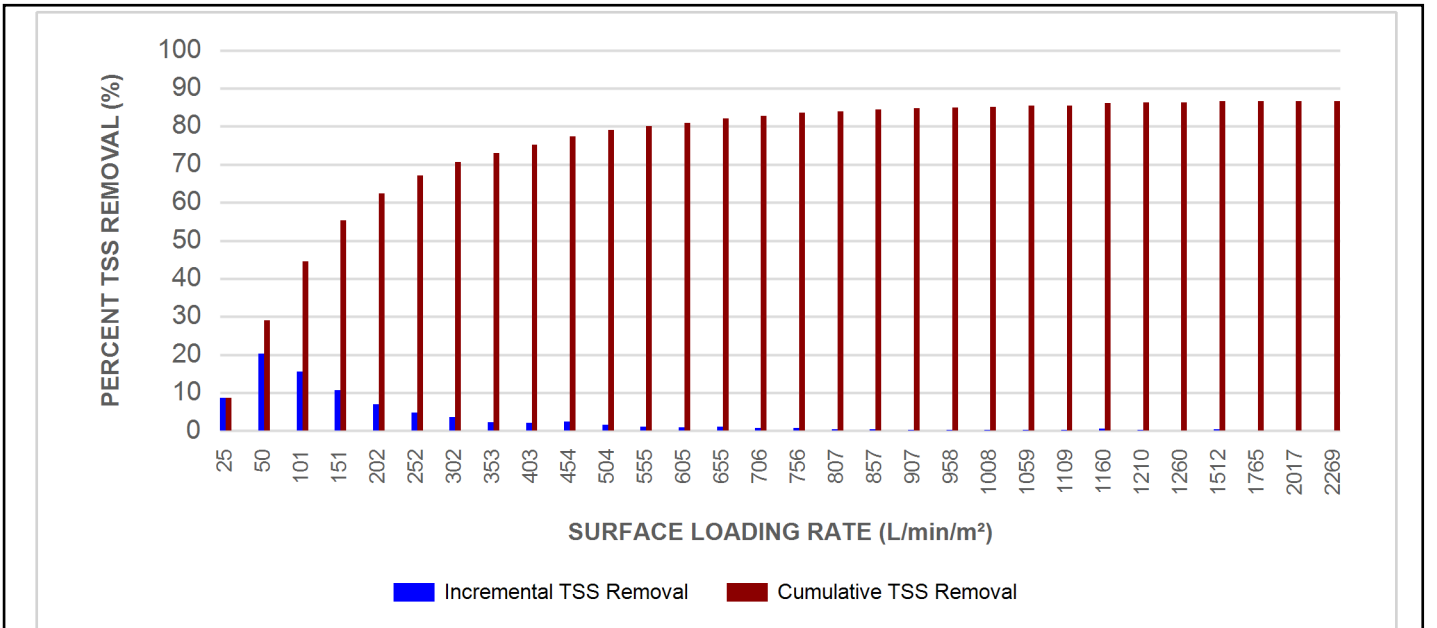

Stormceptor® EF Sizing Report

Maximum Pipe Diameter / Peak Conveyance

Stormceptor EF / EFO	Model Diameter		Min Angle Inlet / Outlet Pipes	Max Inlet Pipe Diameter		Max Outlet Pipe Diameter		Peak Conveyance Flow Rate	
	(m)	(ft)		(mm)	(in)	(mm)	(in)	(L/s)	(cfs)
EF4 / EFO4	1.2	4	90	609	24	609	24	425	15
EF6 / EFO6	1.8	6	90	914	36	914	36	990	35
EF8 / EFO8	2.4	8	90	1219	48	1219	48	1700	60
EF10 / EFO10	3.0	10	90	1828	72	1828	72	2830	100
EF12 / EFO12	3.6	12	90	1828	72	1828	72	2830	100

SCOUR PREVENTION AND ONLINE CONFIGURATION

► Stormceptor® EF and EFO feature an internal bypass and superior scour prevention technology that have been demonstrated in third-party testing according to the scour testing provisions of the Canadian ETV **Procedure for Laboratory Testing of Oil-Grit Separators**, and the exceptional scour test performance has been third-party verified in accordance with the ISO 14034 ETV protocol. As a result, Stormceptor EF and EFO are approved for online installation, eliminating the need for costly additional bypass structures, piping, and installation expense.

DESIGN FLEXIBILITY

► Stormceptor® EF and EFO offers design flexibility in one simplified platform, accepting stormwater flow from a single inlet pipe or multiple inlet pipes, and/or surface runoff through an inlet grate. The device can also serve as a junction structure, accommodate a 90-degree inlet-to-outlet bend angle, and can be modified to ensure performance in submerged conditions.

OIL CAPTURE AND RETENTION

► While Stormceptor® EF will capture and retain oil from dry weather spills and low intensity runoff, Stormceptor® EFO has demonstrated superior oil capture and greater than 99% oil retention in third-party testing according to the light liquid re-entrainment testing provisions of the Canadian ETV **Procedure for Laboratory Testing of Oil-Grit Separators**. Stormceptor EFO is recommended for sites where oil capture and retention is a requirement.

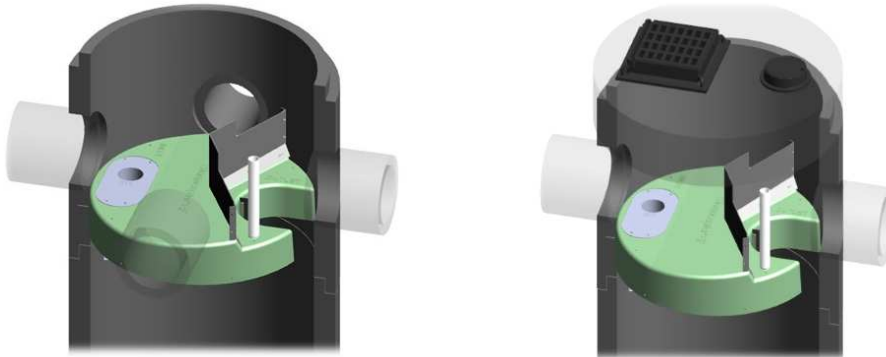

Stormceptor® EF Sizing Report

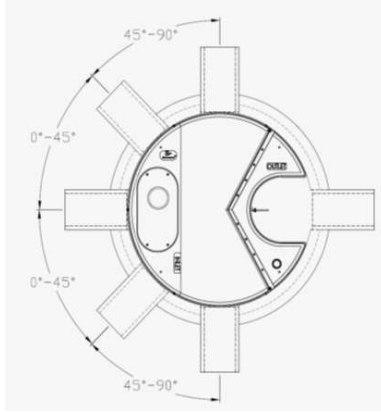

INLET-TO-OUTLET DROP

Elevation differential between inlet and outlet pipe inverts is dictated by the angle at which the inlet pipe(s) enters the unit.

0° - 45° : The inlet pipe is 1-inch (25mm) higher than the outlet pipe.

45° - 90° : The inlet pipe is 2-inches (50mm) higher than the outlet pipe.

HEAD LOSS

The head loss through Stormceptor EF is similar to that of a 60-degree bend structure. The applicable K value for calculating minor losses through the unit is 1.1. For submerged conditions the applicable K value is 3.0.

Pollutant Capacity

Stormceptor EF / EFO	Model Diameter		Depth (Outlet Pipe Invert to Sump Floor)		Oil Volume		Recommended Sediment Maintenance Depth *		Maximum Sediment Volume *		Maximum Sediment Mass **	
	(m)	(ft)	(m)	(ft)	(L)	(Gal)	(mm)	(in)	(L)	(ft ³)	(kg)	(lb)
EF4 / EFO4	1.2	4	1.52	5.0	265	70	203	8	1190	42	1904	5250
EF6 / EFO6	1.8	6	1.93	6.3	610	160	305	12	3470	123	5552	15375
EF8 / EFO8	2.4	8	2.59	8.5	1070	280	610	24	8780	310	14048	38750
EF10 / EFO10	3.0	10	3.25	10.7	1670	440	610	24	17790	628	28464	78500
EF12 / EFO12	3.6	12	3.89	12.8	2475	655	610	24	31220	1103	49952	137875

*Increased sump depth may be added to increase sediment storage capacity

** Average density of wet packed sediment in sump = 1.6 kg/L (100 lb/ft³)

Feature	Benefit	Feature Appeals To
Patent-pending enhanced flow treatment and scour prevention technology	Superior, verified third-party performance	Regulator, Specifying & Design Engineer
Third-party verified light liquid capture and retention for EFO version	Proven performance for fuel/oil hotspot locations	Regulator, Specifying & Design Engineer, Site Owner
Functions as bend, junction or inlet structure	Design flexibility	Specifying & Design Engineer
Minimal drop between inlet and outlet	Site installation ease	Contractor
Large diameter outlet riser for inspection and maintenance	Easy maintenance access from grade	Maintenance Contractor & Site Owner

STANDARD STORMCEPTOR EF/EFO DRAWINGS

[For standard details, please visit http://www.imbriumsystems.com/stormwater-treatment-solutions/stormceptor-ef](http://www.imbriumsystems.com/stormwater-treatment-solutions/stormceptor-ef)

STANDARD STORMCEPTOR EF/EFO SPECIFICATION

[For specifications, please visit http://www.imbriumsystems.com/stormwater-treatment-solutions/stormceptor-ef](http://www.imbriumsystems.com/stormwater-treatment-solutions/stormceptor-ef)

STANDARD PERFORMANCE SPECIFICATION FOR “OIL GRIT SEPARATOR” (OGS) STORMWATER QUALITY TREATMENT DEVICE

PART 1 – GENERAL

1.1 WORK INCLUDED

This section specifies requirements for selecting, sizing, and designing an underground Oil Grit Separator (OGS) device for stormwater quality treatment, with third-party testing results and a Statement of Verification in accordance with ISO 14034 Environmental Management – Environmental Technology Verification (ETV).

1.2 REFERENCE STANDARDS & PROCEDURES

ISO 14034:2016 Environmental management – Environmental technology verification (ETV)

Canadian Environmental Technology Verification (ETV) Program’s **Procedure for Laboratory Testing of Oil-Grit Separators**

1.3 SUBMITTALS

1.3.1 All submittals, including sizing reports & shop drawings, shall be submitted upon request with each order to the contractor then forwarded to the Engineer of Record for review and acceptance. Shop drawings shall detail all OGS components, elevations, and sequence of construction.

1.3.2 Alternative devices shall have features identical to or greater than the specified device, including: treatment chamber diameter, treatment chamber wet volume, sediment storage volume, and oil storage volume.

1.3.3 Unless directed otherwise by the Engineer of Record, OGS stormwater quality treatment product substitutions or alternatives submitted within ten days prior to project bid shall not be accepted. All alternatives or substitutions submitted shall be signed and sealed by a local registered Professional Engineer, based on the exact same criteria detailed in Section 3, in entirety, subject to review and approval by the Engineer of Record.

PART 2 – PRODUCTS

2.1 OGS POLLUTANT STORAGE

The OGS device shall include a sump for sediment storage, and a protected volume for the capture and storage of petroleum hydrocarbons and buoyant gross pollutants. The minimum sediment & petroleum hydrocarbon storage capacity shall be as follows:

2.1.1	4 ft (1219 mm) Diameter OGS Units:	1.19 m ³ sediment / 265 L oil
	6 ft (1829 mm) Diameter OGS Units:	3.48 m ³ sediment / 609 L oil
	8 ft (2438 mm) Diameter OGS Units:	8.78 m ³ sediment / 1,071 L oil
	10 ft (3048 mm) Diameter OGS Units:	17.78 m ³ sediment / 1,673 L oil
	12 ft (3657 mm) Diameter OGS Units:	31.23 m ³ sediment / 2,476 L oil

PART 3 – PERFORMANCE & DESIGN

3.1 GENERAL

The OGS stormwater quality treatment device shall be verified in accordance with ISO 14034:2016 Environmental management – Environmental technology verification (ETV). The OGS stormwater quality treatment device shall

Stormceptor® EF Sizing Report

remove oil, sediment and gross pollutants from stormwater runoff during frequent wet weather events, and retain these pollutants during less frequent high flow wet weather events below the insert within the OGS for later removal during maintenance. The Manufacturer shall have at least ten (10) years of local experience, history and success in engineering design, manufacturing and production and supply of OGS stormwater quality treatment device systems, acceptable to the Engineer of Record.

3.2 SIZING METHODOLOGY

The OGS device shall be engineered, designed and sized to provide stormwater quality treatment based on treating a minimum of 90 percent of the average annual runoff volume and a minimum removal of an annual average 60% of the sediment (TSS) load based on the Particle Size Distribution (PSD) specified in the sizing report for the specified device. Sizing of the OGS shall be determined by use of a minimum ten (10) years of local historical rainfall data provided by Environment Canada. Sizing shall also be determined by use of the sediment removal performance data derived from the ISO 14034 ETV third-party verified laboratory testing data from testing conducted in accordance with the Canadian ETV protocol Procedure for Laboratory Testing of Oil-Grit Separators, as follows:

3.2.1 Sediment removal efficiency for a given surface loading rate and its associated flow rate shall be based on sediment removal efficiency demonstrated at the seven (7) tested surface loading rates specified in the protocol, ranging 40 L/min/m² to 1400 L/min/m², and as stated in the ISO 14034 ETV Verification Statement for the OGS device.

3.2.2 Sediment removal efficiency for surface loading rates between 40 L/min/m² and 1400 L/min/m² shall be based on linear interpolation of data between consecutive tested surface loading rates.

3.2.3 Sediment removal efficiency for surface loading rates less than the lowest tested surface loading rate of 40 L/min/m² shall be assumed to be identical to the sediment removal efficiency at 40 L/min/m². No extrapolation shall be allowed that results in a sediment removal efficiency that is greater than that demonstrated at 40 L/min/m².

3.2.4 Sediment removal efficiency for surface loading rates greater than the highest tested surface loading rate of 1400 L/min/m² shall assume zero sediment removal for the portion of flow that exceeds 1400 L/min/m², and shall be calculated using a simple proportioning formula, with 1400 L/min/m² in the numerator and the higher surface loading rate in the denominator, and multiplying the resulting fraction times the sediment removal efficiency at 1400 L/min/m².

The OGS device shall also have sufficient annual sediment storage capacity as specified and calculated in Section 2.1.

3.3 CANADIAN ETV or ISO 14034 ETV VERIFICATION OF SCOUR TESTING

The OGS device shall have Canadian ETV or ISO 14034 ETV Verification of third-party scour testing conducted in accordance with the Canadian ETV Program's **Procedure for Laboratory Testing of Oil-Grit Separators**.

3.3.1 To be acceptable for on-line installation, the OGS device must demonstrate an average scour test effluent concentration less than 10 mg/L at each surface loading rate tested, up to and including 2600 L/min/m².

3.4 LIGHT LIQUID RE-ENTRAINMENT SIMULATION TESTING

The OGS device shall have Canadian ETV or ISO 14034 ETV Verification of completed third-party Light Liquid Re-entrainment Simulation Testing in accordance with the Canadian ETV **Program's Procedure for Laboratory Testing of Oil-Grit Separators**, with results reported within the Canadian ETV or ISO 14034 ETV verification. This re-entrainment testing is conducted with the device pre-loaded with low density polyethylene (LDPE) plastic beads as a surrogate for light liquids such as oil and fuel. Testing is conducted on the same OGS unit tested for sediment removal to

Stormceptor® EF Sizing Report

assess whether light liquids captured after a spill are effectively retained at high flow rates.

3.4.1 For an OGS device to be an acceptable stormwater treatment device on a site where vehicular traffic occurs and the potential for an oil or fuel spill exists, the OGS device must have reported verified performance results of greater than 99% cumulative retention of LDPE plastic beads for the five specified surface loading rates (ranging 200 L/min/m² to 2600 L/min/m²) in accordance with the Light Liquid Re-entrainment Simulation Testing within the Canadian ETV Program's **Procedure for Laboratory Testing of Oil-Grit Separators**. However, an OGS device shall not be allowed if the Light Liquid Re-entrainment Simulation Testing was performed with screening components within the OGS device that are effective at retaining the LDPE plastic beads, but would not be expected to retain light liquids such as oil and fuel.

APPENDIX H
CITY OF OTTAWA DESIGN CHECKLIST

City of Ottawa

4. Development Servicing Study Checklist

The following section describes the checklist of the required content of servicing studies. It is expected that the proponent will address each one of the following items for the study to be deemed complete and ready for review by City of Ottawa Infrastructure Approvals staff.

The level of required detail in the Servicing Study will increase depending on the type of application. For example, for Official Plan amendments and re-zoning applications, the main issues will be to determine the capacity requirements for the proposed change in land use and confirm this against the existing capacity constraint, and to define the solutions, phasing of works and the financing of works to address the capacity constraint. For subdivisions and site plans, the above will be required with additional detailed information supporting the servicing within the development boundary.

4.1 General Content

Criteria	Location (if applicable)
<input type="checkbox"/> Executive Summary (for larger reports only).	N/A
<input type="checkbox"/> Date and revision number of the report.	On Cover
<input type="checkbox"/> Location map and plan showing municipal address, boundary, and layout of proposed development.	Appendix A
<input type="checkbox"/> Plan showing the site and location of all existing services.	Site Servicing Plan (C102)
<input type="checkbox"/> Development statistics, land use, density, adherence to zoning and official plan, and reference to applicable subwatershed and watershed plans that provide context to which individual developments must adhere.	1.1 Purpose 1.2 Site Description 6.0 Stormwater Management
<input type="checkbox"/> Summary of pre-consultation meetings with City and other approval agencies.	Appendix B
<input type="checkbox"/> Reference and confirm conformance to higher level studies and reports (Master Servicing Studies, Environmental Assessments, Community Design Plans), or in the case where it is not in conformance, the proponent must provide justification and develop a defensible design criteria.	1.1 Purpose 1.2 Site Description 6.0 Stormwater Management
<input type="checkbox"/> Statement of objectives and servicing criteria.	3.0 Pre-Consultation Summary

<input type="checkbox"/> Identification of existing and proposed infrastructure available in the immediate area.	N/A
<input type="checkbox"/> Identification of Environmentally Significant Areas, watercourses and Municipal Drains potentially impacted by the proposed development (Reference can be made to the Natural Heritage Studies, if available).	Ste Grading Plan (C101)
<input type="checkbox"/> Concept level master grading plan to confirm existing and proposed grades in the development. This is required to confirm the feasibility of proposed stormwater management and drainage, soil removal and fill constraints, and potential impacts to neighbouring properties. This is also required to confirm that the proposed grading will not impede existing major system flow paths.	Ste Grading Plan (C101)
<input type="checkbox"/> Identification of potential impacts of proposed piped services on private services (such as wells and septic fields on adjacent lands) and mitigation required to address potential impacts.	N/A
<input type="checkbox"/> Proposed phasing of the development, if applicable.	N/A
<input type="checkbox"/> Reference to geotechnical studies and recommendations concerning servicing.	Section 2.0 Background Studies, Standards and References
<input type="checkbox"/> All preliminary and formal site plan submissions should have the following information: <ul style="list-style-type: none"> ○ Metric scale ○ North arrow (including construction North) ○ Key plan ○ Name and contact information of applicant and property owner ○ Property limits including bearings and dimensions ○ Existing and proposed structures and parking areas ○ Easements, road widening and rights-of-way ○ Adjacent street names 	Ste Grading Plan (C101)

4.2 Development Servicing Report: Water

Criteria	Location (if applicable)
<input type="checkbox"/> Confirm consistency with Master Servicing Study, if available	N/A
<input type="checkbox"/> Availability of public infrastructure to service proposed development	N/A
<input type="checkbox"/> Identification of system constraints	N/A
<input type="checkbox"/> Identify boundary conditions	Appendix C
<input type="checkbox"/> Confirmation of adequate domestic supply and pressure	N/A
<input type="checkbox"/> Confirmation of adequate fire flow protection and confirmation that fire flow is calculated as per the Fire Underwriter's Survey. Output should show available fire flow at locations throughout the development.	Appendix C
<input type="checkbox"/> Provide a check of high pressures. If pressure is found to be high, an assessment is required to confirm the application of pressure reducing valves.	N/A
<input type="checkbox"/> Definition of phasing constraints. Hydraulic modeling is required to confirm servicing for all defined phases of the project including the ultimate design	N/A
<input type="checkbox"/> Address reliability requirements such as appropriate location of shut-off valves	N/A
<input type="checkbox"/> Check on the necessity of a pressure zone boundary modification.	N/A
<input type="checkbox"/> Reference to water supply analysis to show that major infrastructure is capable of delivering sufficient water for the proposed land use. This includes data that shows that the expected demands under average day, peak hour and fire flow conditions provide water within the required pressure range	Appendix C, Section 4.2

<input type="checkbox"/> Description of the proposed water distribution network, including locations of proposed connections to the existing system, provisions for necessary looping, and appurtenances (valves, pressure reducing valves, valve chambers, and fire hydrants) including special metering provisions.	Site Servicing Plan (C101)
<input type="checkbox"/> Description of off-site required feeder mains, booster pumping stations, and other water infrastructure that will be ultimately required to service proposed development, including financing, interim facilities, and timing of implementation.	N/A
<input type="checkbox"/> Confirmation that water demands are calculated based on the City of Ottawa Design Guidelines.	Appendix C
<input type="checkbox"/> Provision of a model schematic showing the boundary conditions locations, streets, parcels, and building locations for reference.	N/A

4.3 Development Servicing Report: Wastewater

Criteria	Location (if applicable)
<input type="checkbox"/> Summary of proposed design criteria (Note: Wet-weather flow criteria should not deviate from the City of Ottawa Sewer Design Guidelines. Monitored flow data from relatively new infrastructure cannot be used to justify capacity requirements for proposed infrastructure).	N/A
<input type="checkbox"/> Confirm consistency with Master Servicing Study and/or justifications for deviations.	N/A
<input type="checkbox"/> Consideration of local conditions that may contribute to extraneous flows that are higher than the recommended flows in the guidelines. This includes groundwater and soil conditions, and age and condition of sewers.	N/A
<input type="checkbox"/> Description of existing sanitary sewer available for discharge of wastewater from proposed development.	Section 5.2 Proposed Sanitary Sewer

<input type="checkbox"/> Verify available capacity in downstream sanitary sewer and/or identification of upgrades necessary to service the proposed development. (Reference can be made to previously completed Master Servicing Study if applicable)	Section 5.3 Proposed Sanitary Design
<input type="checkbox"/> Calculations related to dry-weather and wet-weather flow rates from the development in standard MOE sanitary sewer design table (Appendix 'C') format.	N/A
<input type="checkbox"/> Description of proposed sewer network including sewers, pumping stations, and forcemains.	Section 5.2 Proposed Sanitary Sewer
<input type="checkbox"/> Discussion of previously identified environmental constraints and impact on servicing (environmental constraints are related to limitations imposed on the development in order to preserve the physical condition of watercourses, vegetation, soil cover, as well as protecting against water quantity and quality).	N/A
<input type="checkbox"/> Pumping stations: impacts of proposed development on existing pumping stations or requirements for new pumping station to service development.	N/A
<input type="checkbox"/> Forcemain capacity in terms of operational redundancy, surge pressure and maximum flow velocity.	N/A
<input type="checkbox"/> Identification and implementation of the emergency overflow from sanitary pumping stations in relation to the hydraulic grade line to protect against basement flooding.	N/A
<input type="checkbox"/> Special considerations such as contamination, corrosive environment etc.	N/A

4.4 Development Servicing Report: Stormwater Checklist

Criteria	Location (if applicable)
<input type="checkbox"/> Description of drainage outlets and downstream constraints including legality of outlets (i.e. municipal drain, right-of-way, watercourse, or private property)	Section 6.0 Stormwater Sewer Design & Section 7.0 Proposed Stormwater Management
<input type="checkbox"/> Analysis of available capacity in existing public infrastructure.	N/A
<input type="checkbox"/> A drawing showing the subject lands, its surroundings, the receiving watercourse, existing drainage patterns, and proposed drainage pattern.	Pre & Post-Development Plans
<input type="checkbox"/> Water quantity control objective (e.g. controlling post-development peak flows to pre-development level for storm events ranging from the 2 or 5-year event (dependent on the receiving sewer design) to 100-year return period); if other objectives are being applied, a rationale must be included with reference to hydrologic analyses of the potentially affected subwatersheds, taking into account long-term cumulative effects.	Section 6.0 Stormwater Sewer Design & Section 7.0 Proposed Stormwater Management
<input type="checkbox"/> Water Quality control objective (basic, normal or enhanced level of protection based on the sensitivities of the receiving watercourse) and storage requirements.	Section 6.0 Stormwater Sewer Design & Section 7.0 Proposed Stormwater Management
<input type="checkbox"/> Description of the stormwater management concept with facility locations and descriptions with references and supporting information.	Section 6.0 Stormwater Sewer Design & Section 7.0 Proposed Stormwater Management
<input type="checkbox"/> Set-back from private sewage disposal systems.	N/A
<input type="checkbox"/> Watercourse and hazard lands setbacks.	N/A
<input type="checkbox"/> Record of pre-consultation with the Ontario Ministry of Environment and the Conservation Authority that has jurisdiction on the affected watershed.	N/A
<input type="checkbox"/> Confirm consistency with sub-watershed and Master Servicing Study, if applicable study exists.	N/A
<input type="checkbox"/> Storage requirements (complete with calculations) and conveyance capacity for minor events (1:5-year return period) and major events (1:100-year return period).	Appendix G

<input type="checkbox"/> Identification of watercourses within the proposed development and how watercourses will be protected, or, if necessary, altered by the proposed development with applicable approvals.	Site Grading Plan
<input type="checkbox"/> Calculate pre-and post development peak flow rates including a description of existing site conditions and proposed impervious areas and drainage catchments in comparison to existing conditions.	Section 7.0 Proposed Stormwater Management Appendix G
<input type="checkbox"/> Any proposed diversion of drainage catchment areas from one outlet to another.	Section 6.0 Stormwater Sewer Design & Section 7.0 Proposed Stormwater Management
<input type="checkbox"/> Proposed minor and major systems including locations and sizes of stormwater trunk sewers, and stormwater management facilities.	Section 6.0 Stormwater Sewer Design & Section 7.0 Proposed Stormwater Management
<input type="checkbox"/> If quantity control is not proposed, demonstration that downstream system has adequate capacity for the post-development flows up to and including the 100-year return period storm event.	N/A
<input type="checkbox"/> Identification of potential impacts to receiving watercourses	N/A
<input type="checkbox"/> Identification of municipal drains and related approval requirements.	N/A
<input type="checkbox"/> Descriptions of how the conveyance and storage capacity will be achieved for the development.	Section 6.0 Stormwater Sewer Design & Section 7.0 Proposed Stormwater Management
<input type="checkbox"/> 100-year flood levels and major flow routing to protect proposed development from flooding for establishing minimum building elevations (MBE) and overall grading.	Site Grading Plan (C101)
<input type="checkbox"/> Inclusion of hydraulic analysis including hydraulic grade line elevations.	N/A

<input type="checkbox"/> Description of approach to erosion and sediment control during construction for the protection of receiving watercourse or drainage corridors.	Section 8.0 Sediment & Erosion Control
<input type="checkbox"/> Identification of floodplains – proponent to obtain relevant floodplain information from the appropriate Conservation Authority. The proponent may be required to delineate floodplain elevations to the satisfaction of the Conservation Authority if such information is not available or if information does not match current conditions.	N/A
<input type="checkbox"/> Identification of fill constraints related to floodplain and geotechnical investigation.	N/A

4.5 Approval and Permit Requirements: Checklist

The Servicing Study shall provide a list of applicable permits and regulatory approvals necessary for the proposed development as well as the relevant issues affecting each approval. The approval and permitting shall include but not be limited to the following:

Criteria	Location (if applicable)
<input type="checkbox"/> Conservation Authority as the designated approval agency for modification of floodplain, potential impact on fish habitat, proposed works in or adjacent to a watercourse, cut/fill permits and Approval under Lakes and Rivers Improvement Act. The Conservation Authority is not the approval authority for the Lakes and Rivers Improvement Act. Where there are Conservation Authority regulations in place, approval under the Lakes and Rivers Improvement Act is not required, except in cases of dams as defined in the Act.	N/A
<input type="checkbox"/> Application for Certificate of Approval (CofA) under the Ontario Water Resources Act.	N/A
<input type="checkbox"/> Changes to Municipal Drains.	N/A
<input type="checkbox"/> Other permits (National Capital Commission, Parks Canada, Public Works and Government Services Canada, Ministry of Transportation etc.)	N/A

4.6 Conclusion Checklist

Criteria	Location (if applicable)
<input type="checkbox"/> Clearly stated conclusions and recommendations	Section 9.0 Summary Section 10.0 Recommendations
<input type="checkbox"/> Comments received from review agencies including the City of Ottawa and information on how the comments were addressed. Final sign-off from the responsible reviewing agency.	All are stamped
<input type="checkbox"/> All draft and final reports shall be signed and stamped by a professional Engineer registered in Ontario	All are stamped

11.0 STATEMENT OF LIMITATIONS

This report was produced for the exclusive use of 1531 St. Laurent Limited Partnership. The purpose of the report is to assess the existing stormwater management system and provide recommendations and designs for the post-construction scenario that are in compliance with the guidelines and standards from the Ministry of the Environment, Conservation and Parks, City of Ottawa and local approval agencies. McIntosh Perry reviewed the site information and background documents listed in Section 2.0 of this report. While the previous data was reviewed by McIntosh Perry and site visits were performed, no field verification/measures of any information were conducted.

Any use of this review by a third party, or any reliance on decisions made based on it, without a reliance report is the responsibility of such third parties. McIntosh Perry accepts no responsibility for damages, if any, suffered by any third party as a result of decisions or actions made based on this review.

The findings, conclusions and/or recommendations of this report are only valid as of the date of this report. No assurance is made regarding any changes in conditions subsequent to this date. If additional information is discovered or becomes available at a future date, McIntosh Perry should be requested to re-evaluate the conclusions presented in this report, and provide amendments, if required.