



KEY PLAN, NTS

- GENERAL NOTES**
1. ALL GENERAL SITE INFORMATION AND CONDITIONS COMPILED FROM ARCHITECT'S AND ENGINEER'S PLANS AND SURVEYS.
 2. DO NOT SCALE THIS DRAWING.
 3. REPORT ANY DISCREPANCIES PRIOR TO COMMENCING WORK. NO RESPONSIBILITY IS BORN BY THE LANDSCAPE ARCHITECT FOR UNKNOWN SUBSURFACE CONDITIONS.
 4. REINSTATE ALL AREAS AND ITEMS DAMAGED AS A RESULT OF CONSTRUCTION ACTIVITIES TO THE SATISFACTION OF THE LANDSCAPE ARCHITECT.
 5. DRAWING MAY NOT BE USED FOR CONSTRUCTION UNTIL SIGNED BY LANDSCAPE ARCHITECT AS ISSUED FOR CONSTRUCTION.
 6. THE ACCURACY OF THE POSITION OF UTILITIES IS NOT GUARANTEED.
 7. INDIVIDUAL UTILITY CO. MUST BE CONTACTED FOR CONFIRMATION OF UTILITY EXISTENCE AND LOCATION PRIOR TO DIGGING.
 8. THIS DRAWING IS AN INSTRUMENT OF SERVICE AND REQUIRES THE PERMISSION OF THE LANDSCAPE ARCHITECT FOR USE. COPYRIGHT IS RESERVED BY THE LANDSCAPE ARCHITECT, DAVID M. LASHLEY.

- 2 2024-05-17 REISSUED FOR SPC
- 1 2023-05-15 ISSUED FOR SPC

NO.	DATE	DESCRIPTION
2	2024-05-17	REISSUED FOR SPC
1	2023-05-15	ISSUED FOR SPC

SEAL: [Professional Seal]

NORTH: [North Arrow]

OWNERSHIP:
 SCARBELLI REALTIES INC.
 44 CHAMBERLAIN AVENUE
 OTTAWA, ON, K1S 1V9

LASHLEY + ASSOCIATES
 LANDSCAPE ARCHITECTURE

202, 660 GLADSTONE AVENUE
 OTTAWA, ON K1V 2E6
 T 613 233 8579 x102
 F 613 233 4051
 W LashleyLA.com
 E Mail@LashleyLA.com

PROJECT:
30 - 48 CHAMBERLAIN AVENUE
 30 - 48 CHAMBERLAIN AVENUE,
 OTTAWA, ONTARIO, K1S 1V9

DRAWING TITLE:
LANDSCAPE PLAN

DATE: 2024-05-10 **DRAWING NO.:**
DRAWN SCALE: 1:100 **L0-01**
DRAWN BY: AY
LA PROJECT NO.: 23855-1 **REV NO.:** 0

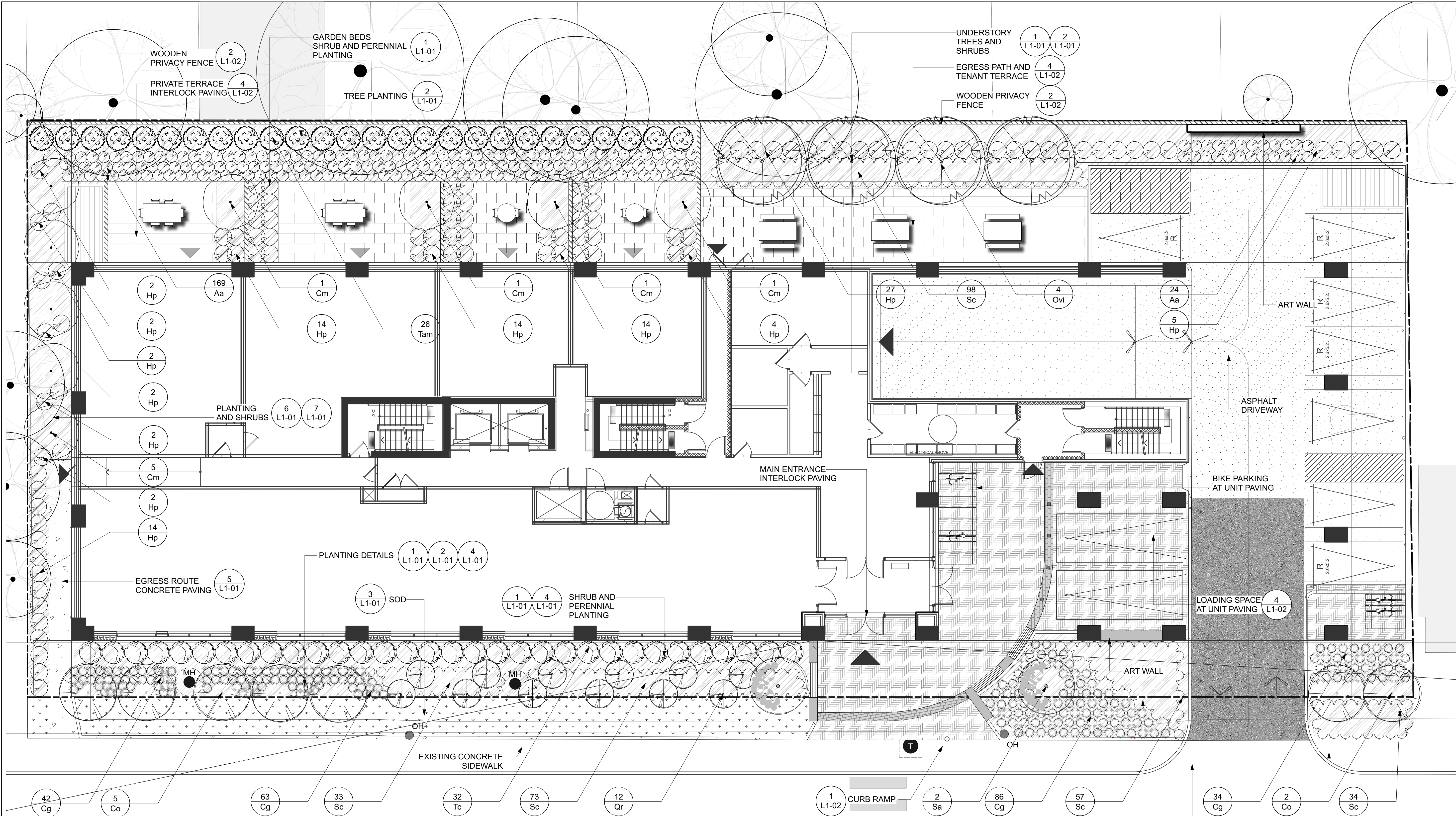

1 **LANDSCAPE PLAN**
 Scale: 1:100

GRAPHIC SCALE
 0 1 2 3 4 5m

LEGEND

[Dashed Line]	PROPERTY LINE	[Hatched Box]	MULCH
[Brick Pattern]	PATIO SLABS	[Dotted Box]	SOD
[Square Pattern]	UNIT PAVERS	[Circle with M]	MANHOLE
[Stippled Box]	PARKING LOT ASPHALT	[Circle with T]	TRAFFIC MANHOLE
[Dark Stippled Box]	HEAVY DUTY ASPHALT	[Circle with O]	HYDROPOLE
[Light Stippled Box]	LIGHT DUTY CONCRETE WALKWAY	[Planting Symbols]	PROPOSED PLANTING
[Horizontal Lines]	WALL MOUNTED BENCHES	[Square]	BOLLARDS

PLANT LIST

DECIDUOUS TREES					
ID	Quantity	Latin Name	Common Name	Scheduled Size	Notes
Co	7	Celtis occidentalis	Hackberry	65mm CAL	
Cm	9	Cornus mas	Cornelian cherry	250mm CAL	
Ovi	4	Ostrya virginiana	Ironwood	65mm CAL	
Qr	12	Quercus robur x bicolor 'Nadler'	Kindred Spirit White Oak	65mm CAL	
Sa	2	Sorbus aucuparia	Pyramidal Mountain Ash	250cm WB	
SHRUBS					
ID	Quantity	Latin Name	Common Name	Scheduled Size	Notes
Tc	32	Taxus cuspidata 'Nana Aurea'	Dwarf Golden Japanese Yew	5 gal pot	
Tam	26	Taxus x Media 'Hicksii'	Hick's Yew	150cm WB	
GRASSES					
ID	Quantity	Latin Name	Common Name	Scheduled Size	Notes
Cg	225	Carex grayi	Gray sedge	4" pot	
PERENNIALS					
ID	Quantity	Latin Name	Common Name	Scheduled Size	Notes
Aa	193	Astilbe arendsii 'Bridal Veil'	Bridal Veil False Spirea	1 gal pot	
Hp	105	Hosta	Plaintain lilies	2 gal pot	
Sc	295	Sanguinaria canadensis	Bloodroot	4" pot	



KEY PLAN, NTS

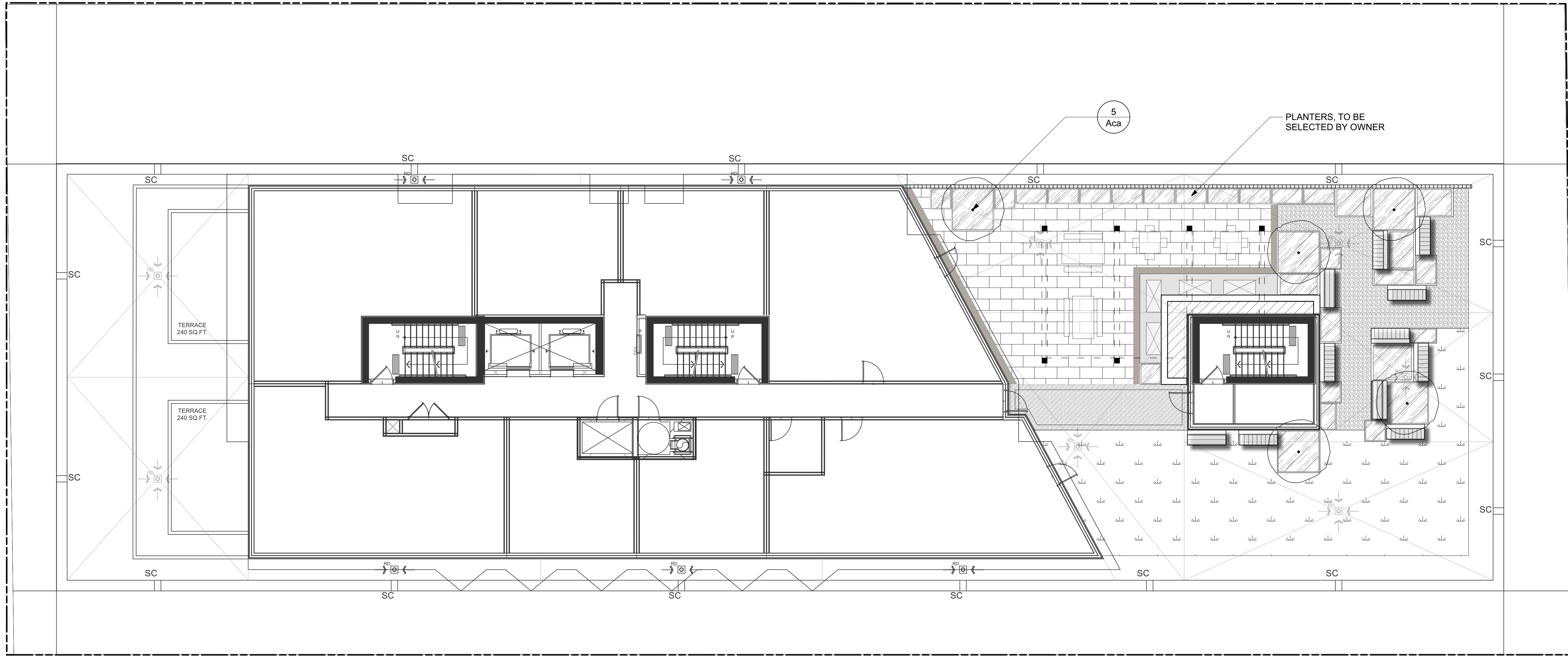

GENERAL NOTES

1. ALL GENERAL SITE INFORMATION AND CONDITIONS COMPILED FROM ARCHITECT'S AND ENGINEER'S PLANS AND SURVEYS.
2. DO NOT SCALE THIS DRAWING.
3. REPORT ANY DISCREPANCIES PRIOR TO COMMENCING WORK. NO RESPONSIBILITY IS BORN BY THE LANDSCAPE ARCHITECT FOR UNKNOWN SUBSURFACE CONDITIONS.
4. REINSTATE ALL AREAS AND ITEMS DAMAGED AS A RESULT OF CONSTRUCTION ACTIVITIES TO THE SATISFACTION OF THE LANDSCAPE ARCHITECT.
5. DRAWING MAY NOT BE USED FOR CONSTRUCTION UNTIL SIGNED BY LANDSCAPE ARCHITECT AS ISSUED FOR CONSTRUCTION.
6. THE ACCURACY OF THE POSITION OF UTILITIES IS NOT GUARANTEED.
7. INDIVIDUAL UTILITY CO. MUST BE CONTACTED FOR CONFIRMATION OF UTILITY EXISTENCE AND LOCATION PRIOR TO DIGGING.
8. THIS DRAWING IS AN INSTRUMENT OF SERVICE AND REQUIRES THE PERMISSION OF THE LANDSCAPE ARCHITECT FOR USE. COPYRIGHT IS RESERVED BY THE LANDSCAPE ARCHITECT, DAVID M. LASHLEY.

2	2024-05-17	REISSUED FOR SPC
1	2023-05-15	ISSUED FOR SPC

NO. DATE DESCRIPTION

SEAL: NORTH:

OWNERSHIP:
 SCARABELLI REALTIES INC.
 44 CHAMBERLAIN AVENUE
 OTTAWA, ON, K1S 1V9

202, 660 GLADSTONE AVENUE
 OTTAWA, ON K1V 2E5
 T 613 233 8579 x102
 F 613 233 4051
 W LashleyLA.com
 E Mail@LashleyLA.com

PROJECT:
30 - 48 CHAMBERLAIN AVENUE
 30 - 48 CHAMBERLAIN AVENUE,
 OTTAWA, ONTARIO, K1S 1V9

DRAWING TITLE:
 LANDSCAPE PLAN - PODIUM

DATE:	2024-05-10	DRAWING NO.:	L0-02
DRAWN SCALE:	1:100	LA PROJECT NO.:	23855-1
DRAWN BY:	AY	REV NO.:	0

1 PODIUM LANDSCAPE PLAN
 L0-02 Scale: 1:100

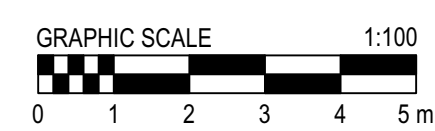

LEGEND

- PROPERTY LINE
- PATIO SLABS
- UNIT PAVERS
- GRAVEL
- MULCH
- ARTIFICIAL SOD

ID	Quantity	Latin Name	Common Name	Scheduled Size	Notes
Aca	5	Amelanchier canadensis 'Princess Diana'	Princess Diana Serviceberry		



KEY PLAN, N.T.S.

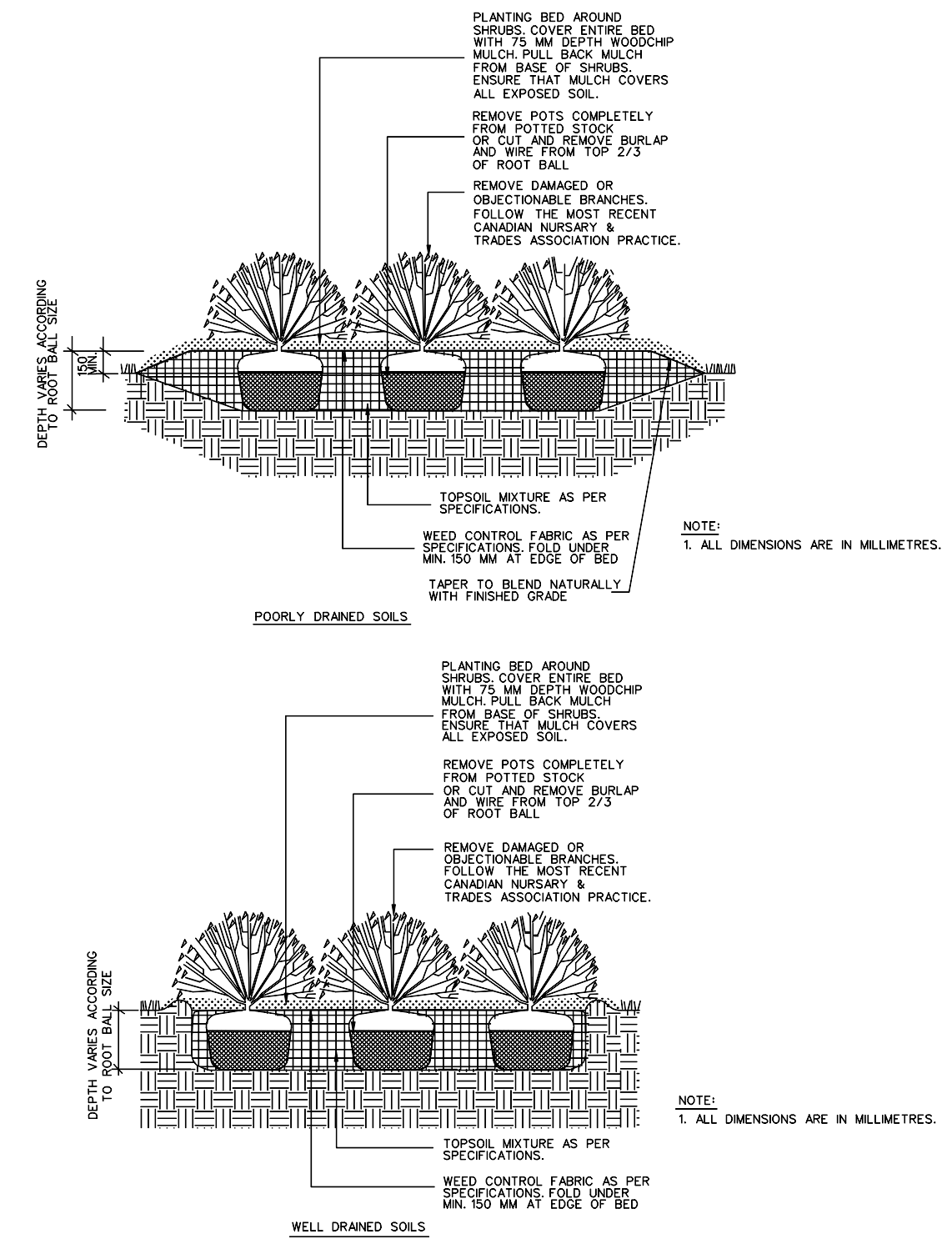

1 SHRUB BED PLANTING
Scale: N.T.S.

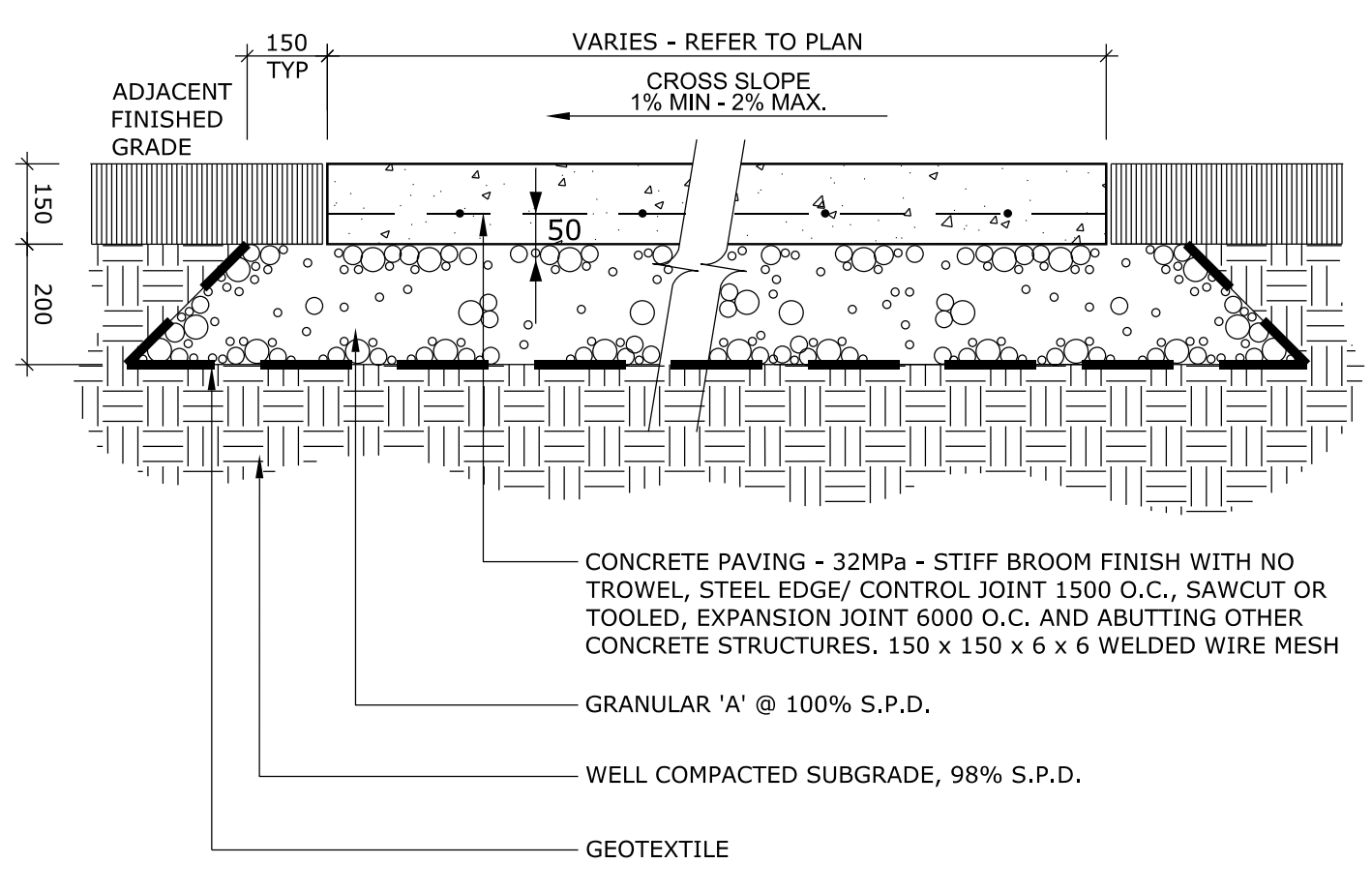

5 LIGHT DUTY WALKWAY CONCRETE PAVING
Scale: N.T.S.

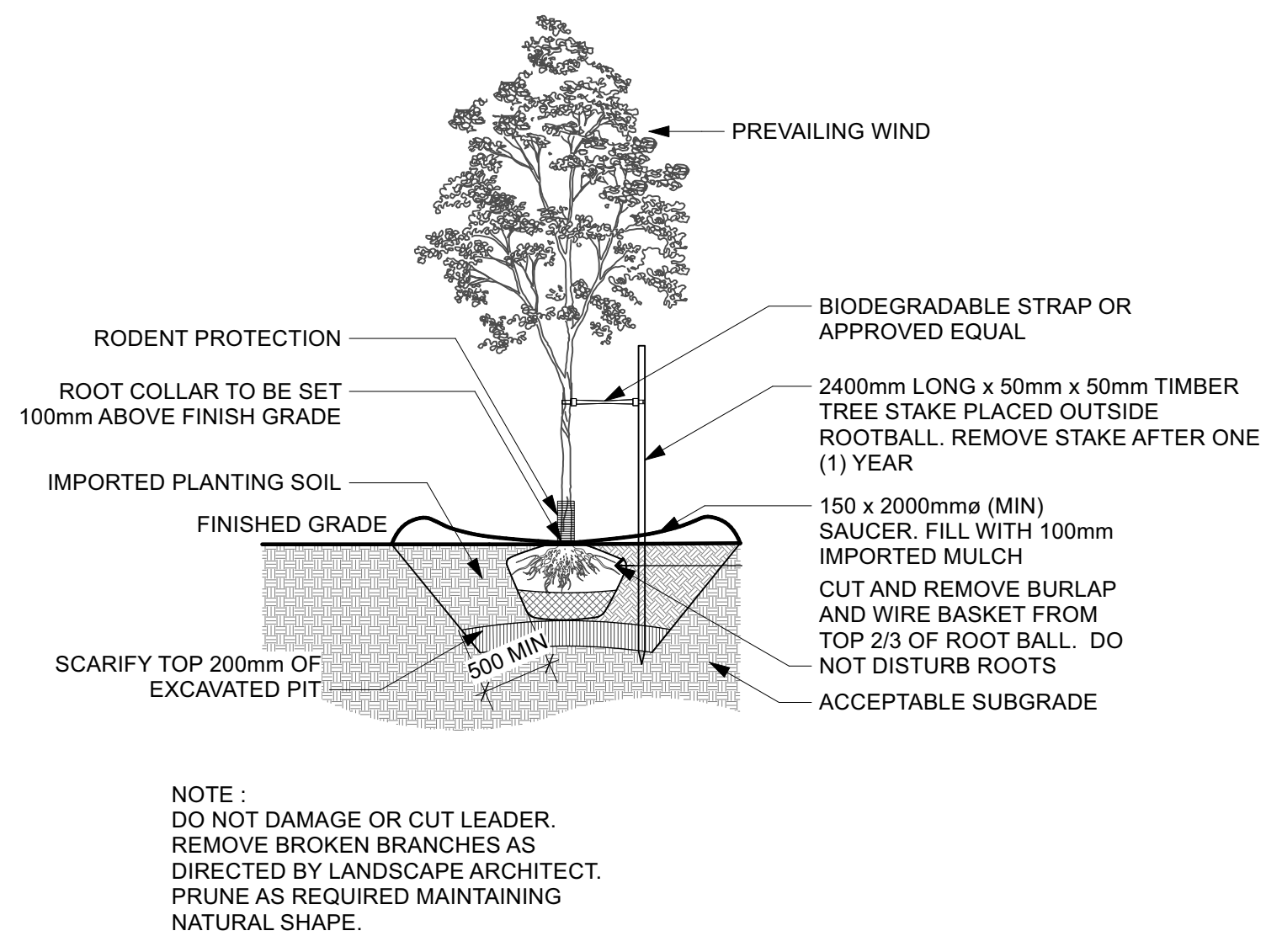

2 DECIDUOUS TREE PLANTING
Scale: 1:50

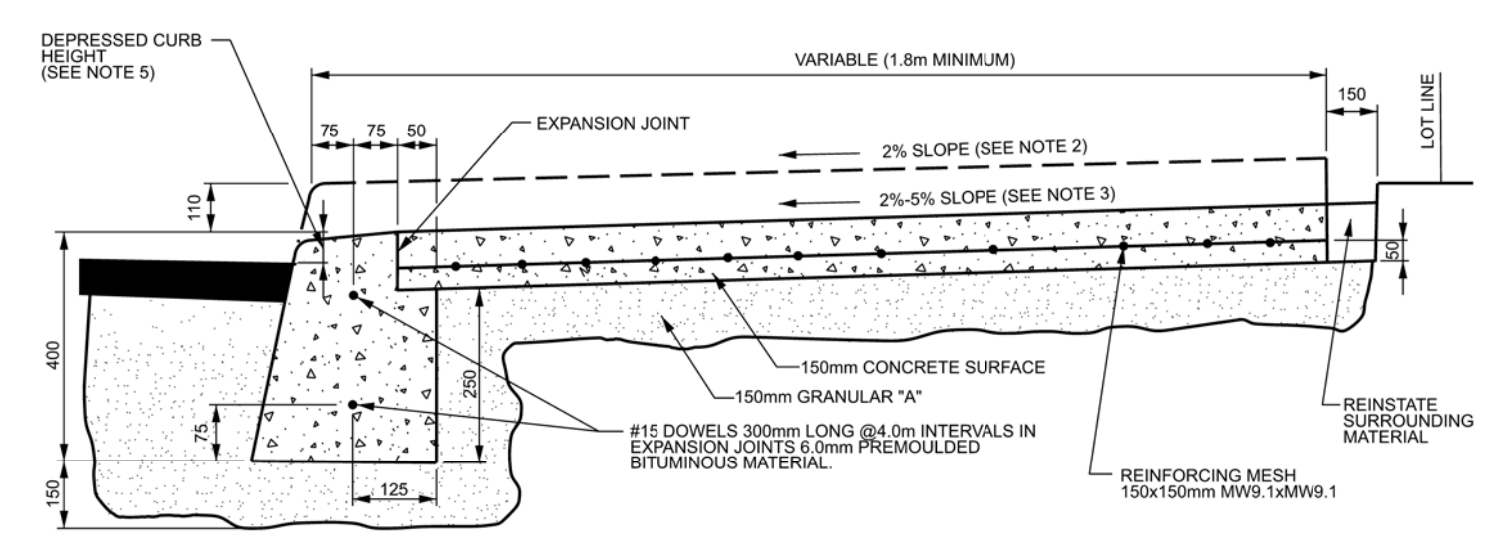
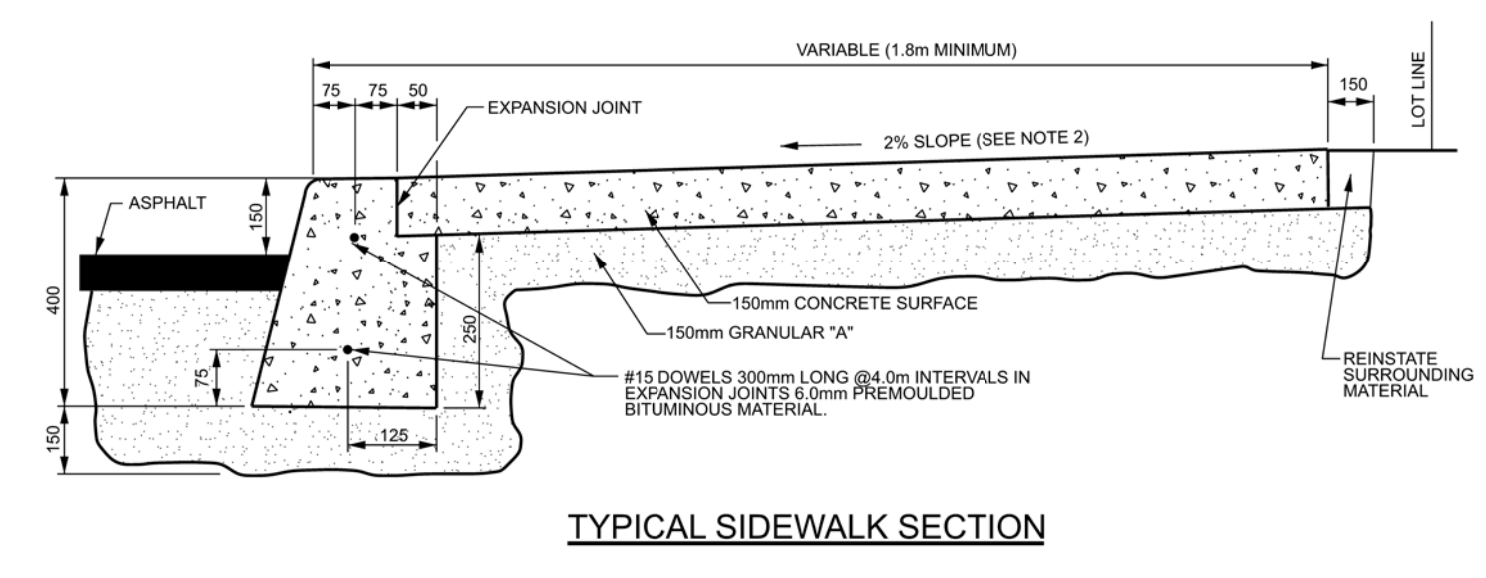

6 CONCRETE BARRIER CURB WITH SIDEWALK
Scale: N.T.S.

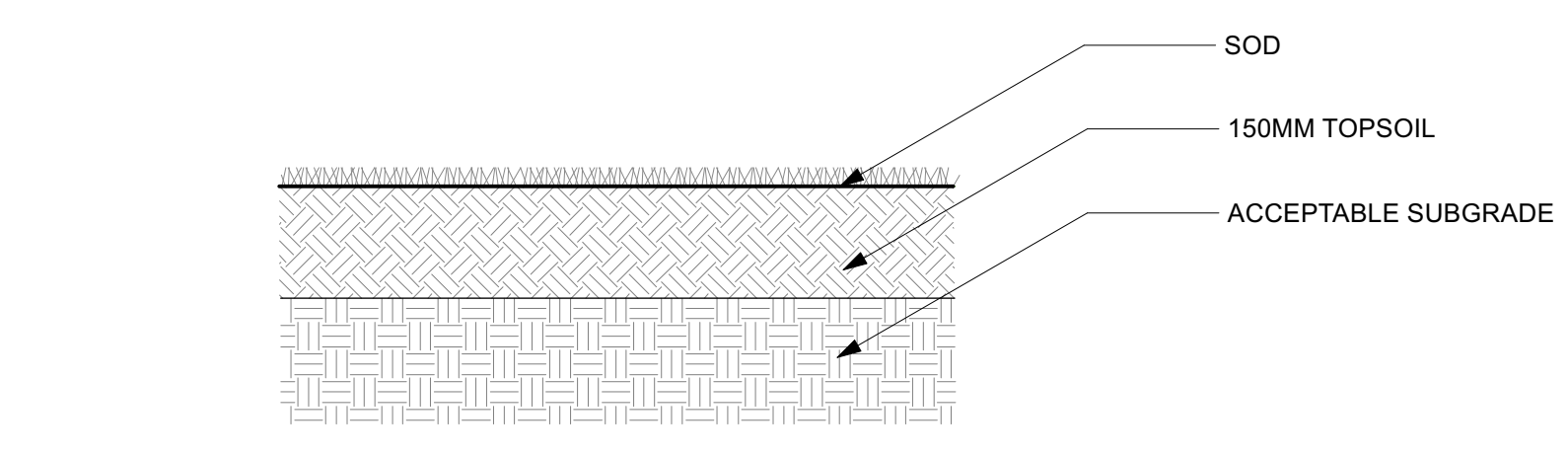

3 SOD PLANTING
Scale: 1:10

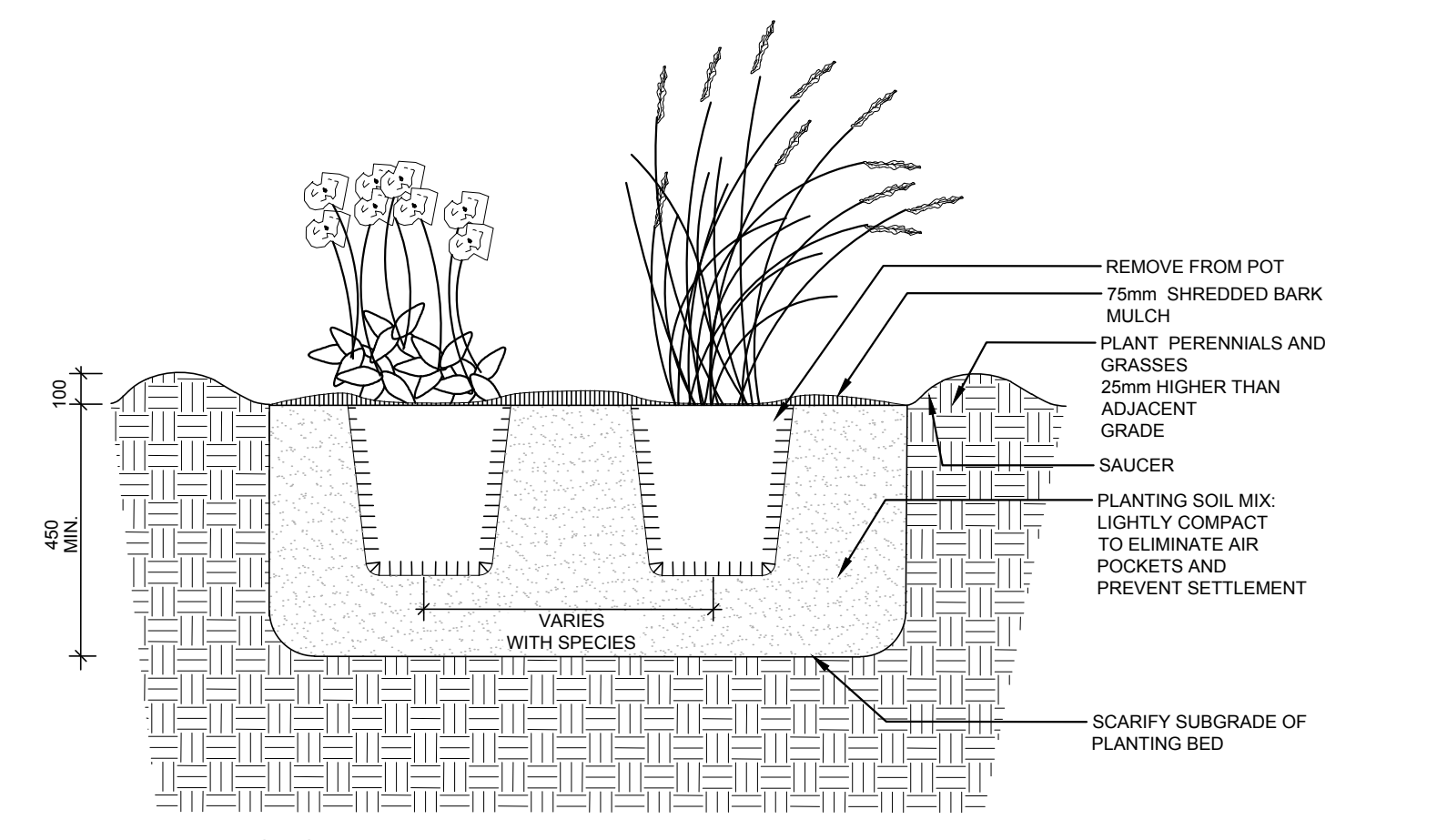

4 PERENNIAL AND ORNAMENTAL GRASS PLANTING
Scale: N.T.S.

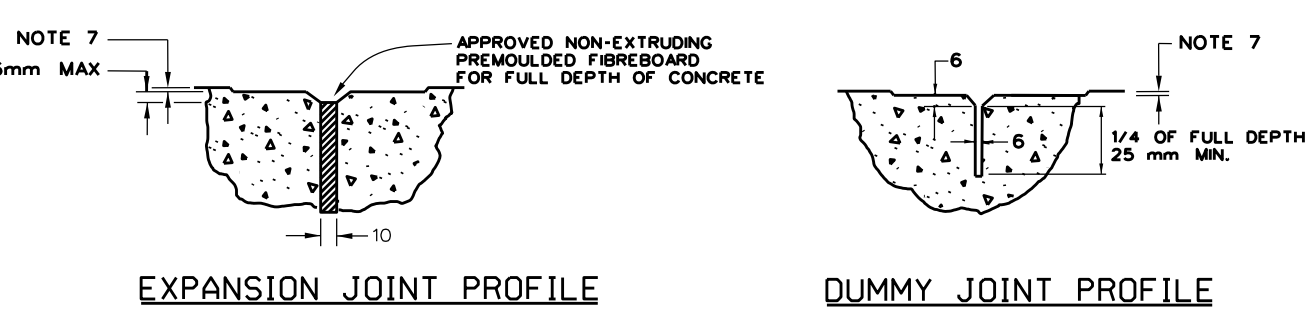
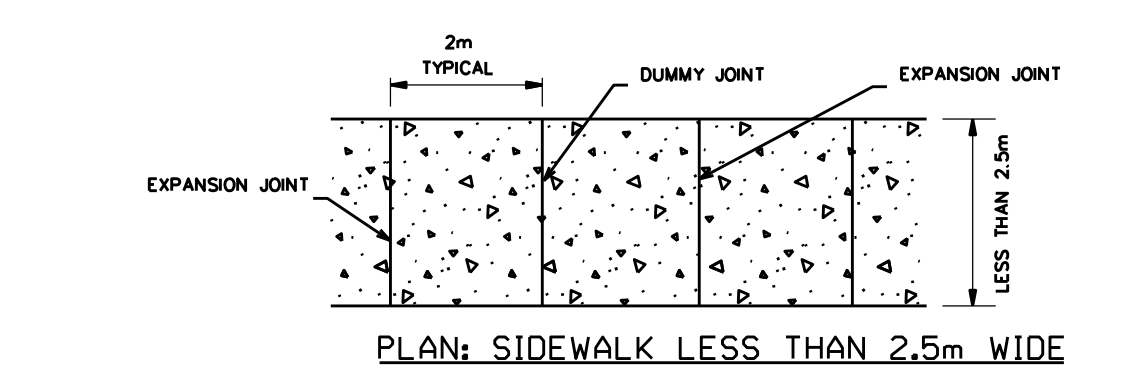
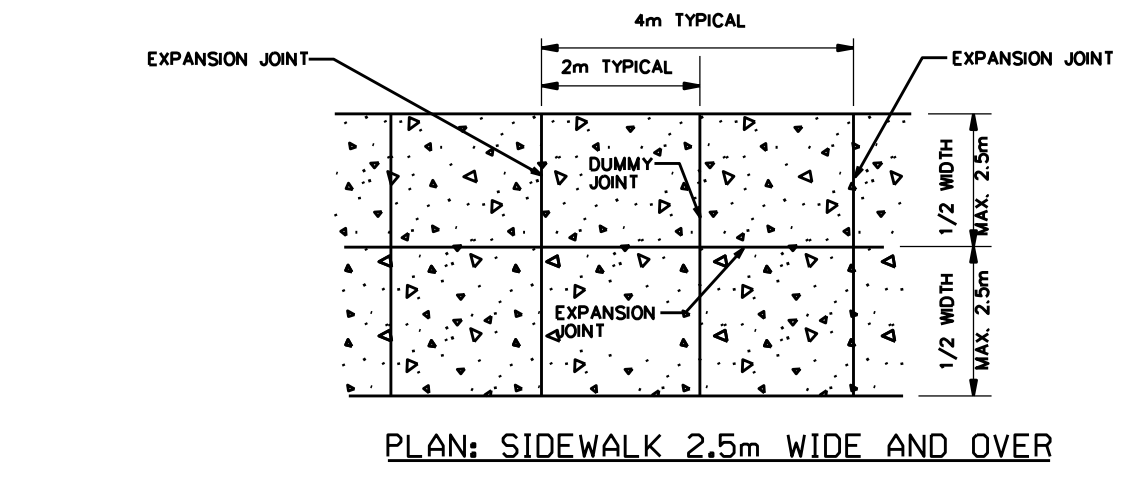

7 SIDEWALK CONSTRUCTION JOINTS
Scale: N.T.S.

- GENERAL NOTES**
1. ALL GENERAL SITE INFORMATION AND CONDITIONS COMPILED FROM ARCHITECT'S AND ENGINEER'S PLANS AND SURVEYS.
 2. DO NOT SCALE THIS DRAWING.
 3. REPORT ANY DISCREPANCIES PRIOR TO COMMENCING WORK. NO RESPONSIBILITY IS BORN BY THE LANDSCAPE ARCHITECT FOR UNKNOWN SUBSURFACE CONDITIONS.
 4. REINSTATE ALL AREAS AND ITEMS DAMAGED AS A RESULT OF CONSTRUCTION ACTIVITIES TO THE SATISFACTION OF THE LANDSCAPE ARCHITECT.
 5. DRAWING MAY NOT BE USED FOR CONSTRUCTION UNTIL SIGNED BY LANDSCAPE ARCHITECT AS ISSUED FOR CONSTRUCTION.
 6. THE ACCURACY OF THE POSITION OF UTILITIES IS NOT GUARANTEED.
 7. INDIVIDUAL UTILITY CO. MUST BE CONTACTED FOR CONFIRMATION OF UTILITY EXISTENCE AND LOCATION PRIOR TO DIGGING.
 8. THIS DRAWING IS AN INSTRUMENT OF SERVICE AND REQUIRES THE PERMISSION OF THE LANDSCAPE ARCHITECT FOR USE. COPYRIGHT IS RESERVED BY THE LANDSCAPE ARCHITECT, DAVID M. LASHLEY.

2	2024-05-17	ISSUED FOR SPC
1	2023-05-15	ISSUED FOR SPC

NO.	DATE	DESCRIPTION
2	2024-05-17	ISSUED FOR SPC
1	2023-05-15	ISSUED FOR SPC

OWNERSHIP:
SCARABELLI REALTIES INC.
44 CHAMBERLAIN AVENUE
OTTAWA, ON, K1S 1V9



PROJECT:
30 - 48 CHAMBERLAIN AVENUE
30 - 48 CHAMBERLAIN AVENUE,
OTTAWA, ONTARIO, K1S 1V9

DRAWING TITLE:
LANDSCAPE DETAILS

DATE:	2024-05-10	DRAWING NO.:	
DRAWN SCALE:	1:100	DRAWN BY:	AY
DRAWN BY:	AY	LA PROJECT NO.:	23855-1
LA PROJECT NO.:	23855-1	REV NO.:	0

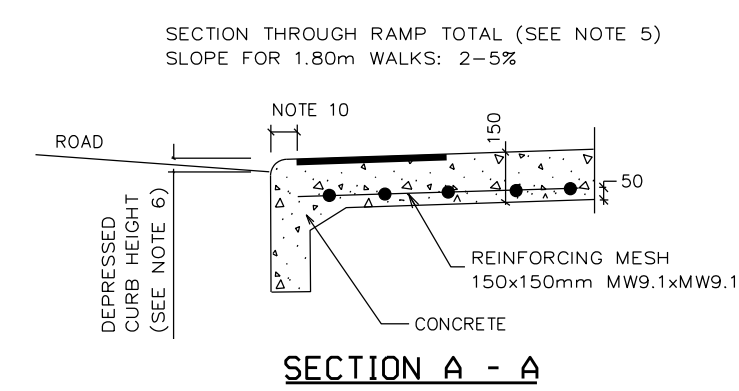
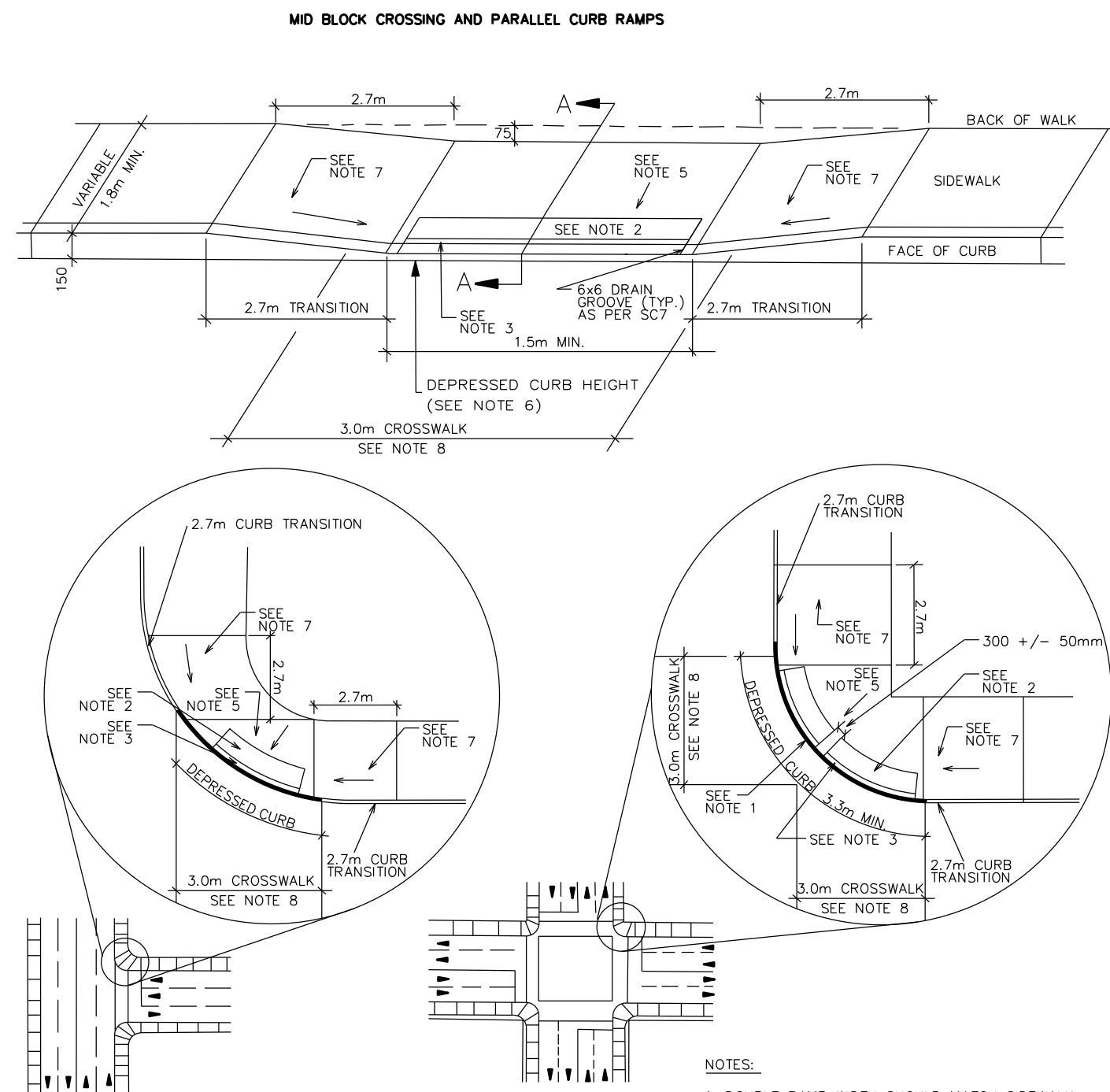

- NOTES:**
- DOUBLE RAMP WIDTH SHOULD MATCH SIDEWALK WIDTH, BE A MINIMUM OF 3.5m WIDE AND PERMIT WHEELCHAIRS TO ENTER CROSSING AT RIGHT ANGLES.
 - APPROVED 610 X WIDTH OF CURB RAMP (1500 MIN) TACTILE WALKING SURFACE INDICATOR, RADIUS TO MATCH CURB
 - 150 TO 200 GAP
 - ALL DIMENSIONS ARE IN MILLIMETRES UNLESS SHOWN OTHERWISE.
 - FOR TRANSITION AREA, MAXIMUM SLOPE OF 2%
 - DEPRESSED CURB HEIGHT - FOR PEDESTRIAN CURB RAMP: 0 TO 6 mm AND FOR PRIVATE ENTRANCES 0 TO 25mm.
 - FOR CURB RAMP SLOPE OF 2% TO 5% MAXIMUM 8%.
 - SUBJECT TO AVOIDANCE OF MEDIANS, CROSSWALK LINES TO CENTRED ON THE CURB RAMP.
 - FOR RETROFIT APPLICATIONS ONLY.
 - FOR MONOLITHIC SIDEWALK, TWISI SHALL BE 300 TO 350mm BACK FROM CURB FACE.

1 PEDESTRIAN CURB RAMP WITHOUT BOULEVARD
Scale: N.T.S

- NOTES:**
- CONTRACTOR TO SUBMIT SHOP DRAWING.
 - ALL LUMBER TO BE EASTERN WHITE CEDAR SELECT.
 - ALL FASTENERS TO BE GALVANIZED.

TOP VIEW

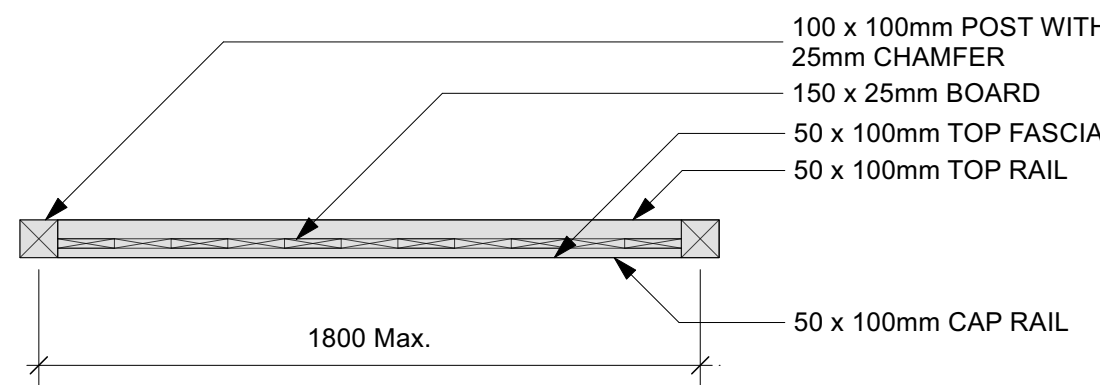

SECTION



ELEVATION

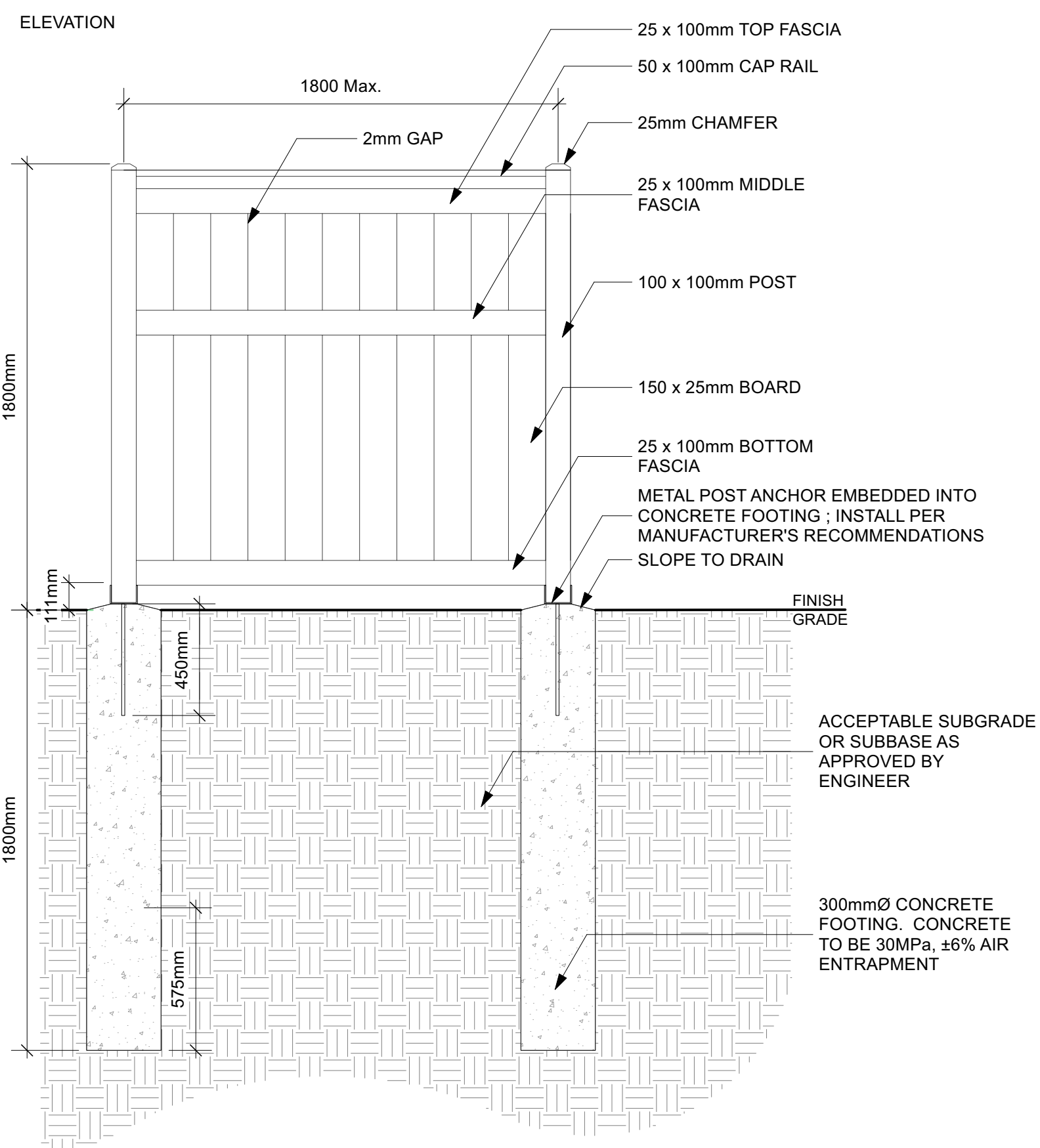

2 WOOD FENCE
Scale: 1:20

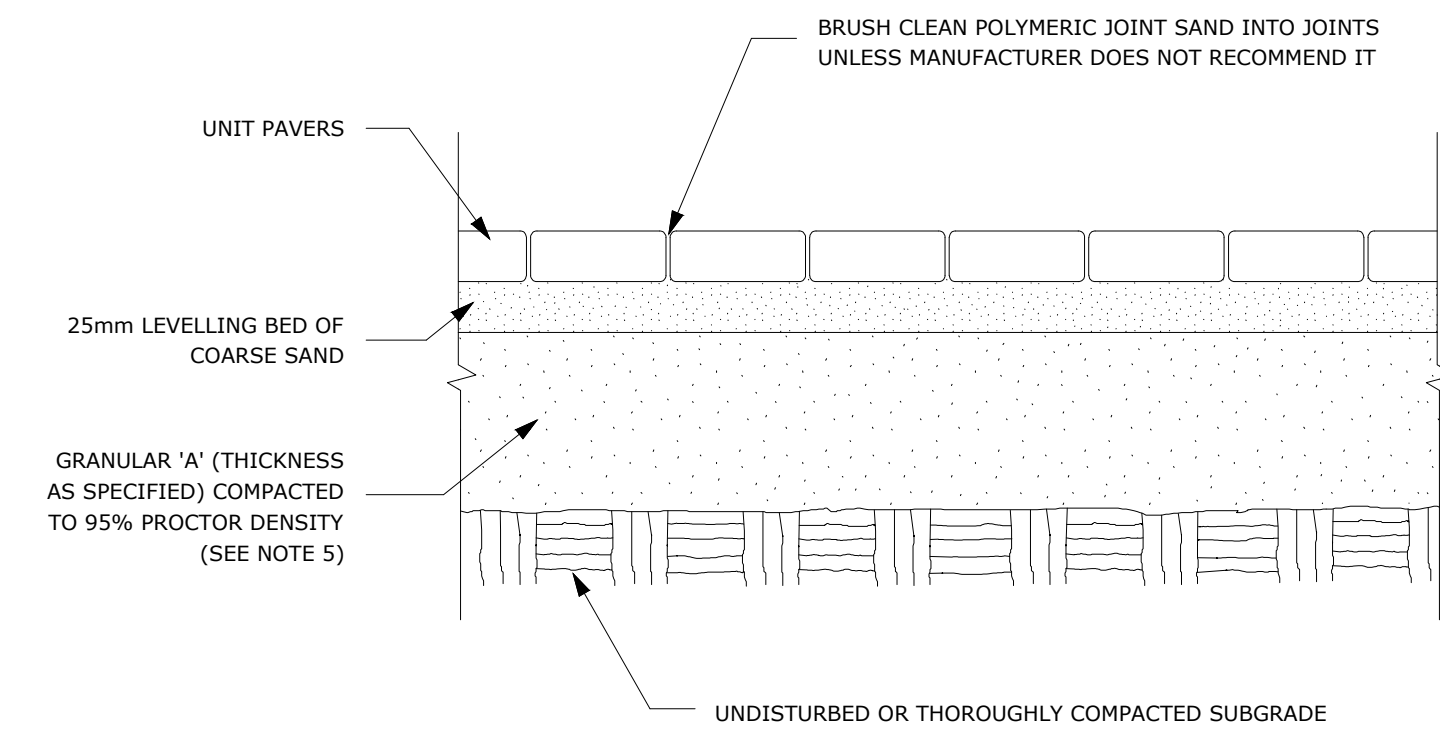

NOTES:

- THE LEVELLING COURSE (BEDDING SAND) SHALL BE PLACED LOOSE, IN A UNIFORM LAYER AT A MAXIMUM DEPTH OF 25mm TO ACHIEVE THE FINAL COMPACTED THICKNESS AND GRADE AS SPECIFIED
- INSTALL SOLID EDGE RESTRAINT BETWEEN UNIT PAVERS AND ANY SOFT SURFACE (SOD, PLANTING BED, ETC.)
- UNIT PAVERS ARE THEN PLACED ON TOP OF THE LEVELLING COURSE AND ADDITIONAL SAND SWEEPED BETWEEN THE UNIT PAVERS
- THE UNIT PAVERS ARE THEN VIBRATED INTO PLACE WITH A VIBRA-PLATE AND WATER IS ADDED TO ASSIST IN THE SETTLING OF THE JOINT SAND
- GRANULAR 'A' DEPTH TO BE 100mm FOR PEDESTRIAN AREAS AND 150mm FOR VEHICULAR ACCESSES, OR AS RECOMMENDED BY GEOTECHNICAL INVESTIGATION
- USE OF THIS DETAIL REQUIRES THE PRIOR APPROVAL OF THE GENERAL MANAGER

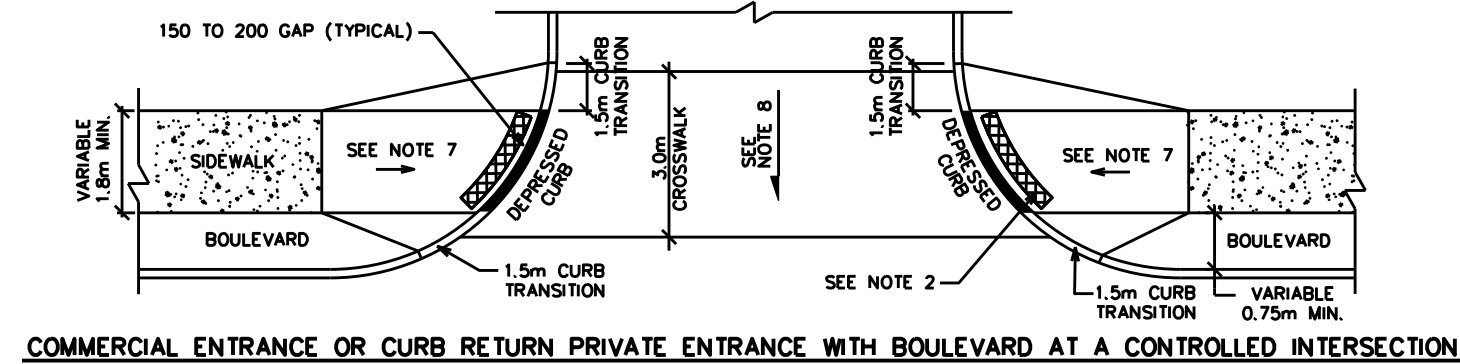
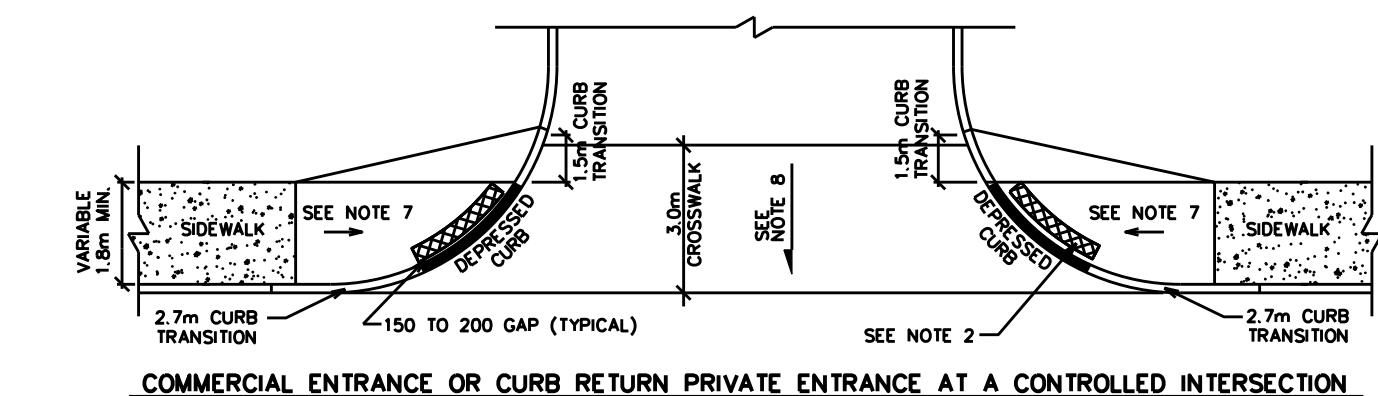

- NOTES:**
- ALL DIMENSIONS ARE IN MILLIMETRES UNLESS SHOWN OTHERWISE.
 - APPROVED 610 X WIDTH OF CURB RAMP (1500MIN) TACTILE WALKING SURFACE INDICATOR, RADIUS TO MATCH CURB. DRAIN GROOVES AS PER SC7.
 - CURB DETAILS SEE SC1.1, SC1.2 AND SC1.3.
 - SIDEWALK DETAILS SEE SC2 AND SC3.
 - CURB RAMP AS PER SC6 AND SC7.
 - CROSSWALK LINES TO BE CENTRED ON THE CURB RAMP.
 - FOR CURB RAMP, SLOPE OF 2% TO 5% MAXIMUM 8%.
 - MAXIMUM SLOPE VARIES, SEE PRIVATE APPROACH BYLAW.
 - CONTROLLED INTERSECTION MEANS AN ENTRANCE LOCATED AT A TRAFFIC SIGNAL OR ALL-WAY STOP CONTROL.

3 CURB RETURN ENTRANCES - CONTROLLED INTERSECTIONS
Scale: N.T.S

4 UNIT PAVING - ON GRANULAR BASE
Scale: N.T.S



KEY PLAN, N.T.S

GENERAL NOTES

- ALL GENERAL SITE INFORMATION AND CONDITIONS COMPILED FROM ARCHITECT'S AND ENGINEER'S PLANS AND SURVEYS.
- DO NOT SCALE THIS DRAWING.
- REPORT ANY DISCREPANCIES PRIOR TO COMMENCING WORK. NO RESPONSIBILITY IS BORN BY THE LANDSCAPE ARCHITECT FOR UNKNOWN SUBSURFACE CONDITIONS.
- REINSTATE ALL AREAS AND ITEMS DAMAGED AS A RESULT OF CONSTRUCTION ACTIVITIES TO THE SATISFACTION OF THE LANDSCAPE ARCHITECT.
- DRAWING MAY NOT BE USED FOR CONSTRUCTION UNTIL SIGNED BY LANDSCAPE ARCHITECT AS ISSUED FOR CONSTRUCTION.
- THE ACCURACY OF THE POSITION OF UTILITIES IS NOT GUARANTEED.
- INDIVIDUAL UTILITY CO. MUST BE CONTACTED FOR CONFIRMATION OF UTILITY EXISTENCE AND LOCATION PRIOR TO DIGGING.
- THIS DRAWING IS AN INSTRUMENT OF SERVICE AND REQUIRES THE PERMISSION OF THE LANDSCAPE ARCHITECT FOR USE. COPYRIGHT IS RESERVED BY THE LANDSCAPE ARCHITECT, DAVID M. LASHLEY.

2	2024-05-17	REISSUED FOR SPC
1	2023-05-15	ISSUED FOR SPC

NO.	DATE	DESCRIPTION
-----	------	-------------

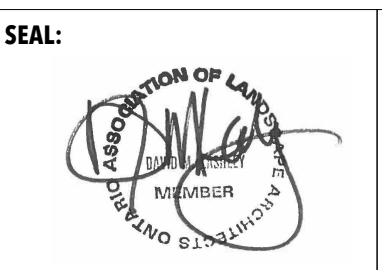

OWNERSHIP:
SCARABELLI REALTIES INC.
44 CHAMBERLAIN AVENUE
OTTAWA, ON, K1S 1V9



PROJECT:
30 - 48 CHAMBERLAIN AVENUE
30 - 48 CHAMBERLAIN AVENUE,
OTTAWA, ONTARIO, K1S 1V9

DRAWING TITLE:
LANDSCAPE DETAILS

DATE:	2024-05-10	DRAWING NO.:	
DRAWN SCALE:	1:100	DRAWN BY:	AY
LA PROJECT NO.:	23855-1	REV NO.:	0

L1-02