



# Stormwater Management and Servicing Report

Proposed Multi-Unit Commercial Development  
5254 Bank Street  
Ottawa, Ontario

Prepared for:

Unpoised Architecture Inc.  
5-16 Sweetland Avenue  
Ottawa, ON. K1N 7T6

Attention: Sam Cox

LRL File No.: 220536-04

December 15, 2022  
Rev. June 27, 2025



## TABLE OF CONTENTS

<b>1</b>	<b>INTRODUCTION AND SITE DESCRIPTION</b>	<b>3</b>
<b>2</b>	<b>EXISTING SITE AND DRAINAGE DESCRIPTION</b>	<b>4</b>
<b>3</b>	<b>SCOPE OF WORK</b>	<b>4</b>
<b>4</b>	<b>WATER SUPPLY AND FIRE PROTECTION</b>	<b>5</b>
4.1	Existing Water Supply Services and Fire Hydrant Coverage	5
4.2	Water Supply Servicing Design	5
<b>5</b>	<b>SANITARY SERVICE</b>	<b>7</b>
5.1	Existing Sanitary Sewer Services	7
5.2	Sanitary Sewer Servicing Design	7
<b>6</b>	<b>STORMWATER MANAGEMENT</b>	<b>8</b>
6.1	Existing Stormwater Infrastructure	8
6.2	Design Criteria	8
6.2.1	Water Quality	8
6.2.2	Water Quantity	9
6.3	Method of Analysis	9
6.4	Proposed Stormwater Quantity Controls	9
<b>7</b>	<b>EROSION AND SEDIMENT CONTROL</b>	<b>11</b>
<b>8</b>	<b>CONCLUSION</b>	<b>11</b>
<b>9</b>	<b>REPORT CONDITIONS AND LIMITATIONS</b>	<b>12</b>



## APPENDICES

<b>Appendix A</b>	<b>Pre-consultation / Correspondence</b>
<b>Appendix B</b>	<b>Water Supply Calculations</b>
<b>Appendix C</b>	<b>Wastewater Collection Calculations</b>
<b>Appendix D</b>	<b>Stormwater Management Calculations</b>
<b>Appendix E</b>	<b>Civil Engineering Drawings</b>
<b>Drawings/Figures</b>	<b>Proposed Site Plan</b>
	<b>Legal Survey</b>

## LIST OF TABLES

Table 1: City of Ottawa Design Guidelines Design Parameters .....	5
Table 2: Summary of Anticipated Demands and Boundary Conditions.....	6
Table 3: Fire Protection Summary Table .....	7
Table 4: Drainage Areas .....	10
Table 5: Stormwater Release Rate & Storage Volume Summary (100 Year) .....	11

## LIST OF FIGURES

Figure 1: Aerial View of Proposed Development .....	3
---	---



## 1 INTRODUCTION AND SITE DESCRIPTION

LRL Associates Ltd. was retained by Unpoised Architecture Inc. to complete a Stormwater Management Analysis and Servicing Brief for a proposed multi-unit commercial building development located at 5254 Bank Street in Ottawa, Ontario. The legal description of the property is Part of Lot 28, Concession 4 (Rideau Front), PIN 04327-0082, City of Ottawa.



**Figure 1: Aerial View of Proposed Development**

The site at 5254 Bank Street has approximately 23 metres of frontage along Bank Street and a depth of approximately 76 metres. The overall lot area is approximately **0.172 ha**.

Currently there is a 1-storey residential building and garage located at the front (East) of the property, and two barns located at the rear (West) of the property. An asphalt driveway provides access to the site from Bank Street. The asphalt driveway provides access to the residential dwelling and garage, which transitions to a gravel driveway providing access to the rear yard barns. The balance of the site is grassed area.

The development proposed consists of a multi-unit commercial development, consisting of multiple bays equipped with overhead doors for vehicular access. A driveway, branching off Bank Street, will provide vehicular access to all the bay doors. A parking lot will be proposed directly North of the driveway. The balance of the site will be grassed area and landscaping elements.



Due to the steep slope down on site from East to West, the West portion of the site will be built up with retaining wall.

This report has been prepared in consideration of the terms and conditions noted above and with the civil drawings prepared for the new development. Should there be any changes in the design features, which may relate to the stormwater considerations, LRL Associates Ltd. Should be advised to review the report recommendations.

## **2 EXISTING SITE AND DRAINAGE DESCRIPTION**

The subject site measures 0.172ha and consists of a 1-storey residential building and garage located at the front (East) of the property, and two barns located at the rear (West) of the property. An asphalt driveway, providing entrance from Bank Street, provides access to the site.

The residential unit was serviced by municipal water. As no sanitary sewer is present along Bank Street adjacent to the property, the dwelling relied on a septic system for sanitary requirements.

As per the topographical survey provided by Farley, Smith and Denis Surveying LTD (dated April 24<sup>th</sup>, 2019), the site slopes down considerable from East to West, with a minor slope down from North to South. Elevations of the existing site range from 115.29m in the northeast corner and 113.64m at the southeast corner, down to 110.55m in the northwest corner and 109.81m at the southwest corner of the site.

Sewer and watermain mapping, along with as-built information collected from the City of Ottawa indicate the following existing infrastructure located within the adjacent right-of-way:

### **Bank Street**

- 406 mm diameter PVC watermain

## **3 SCOPE OF WORK**

As per applicable guidelines, the scope of work includes the following:

### **Stormwater management**

- Calculate the allowable stormwater release rate.
- Calculate the anticipated post-development stormwater release rates.
- Demonstrate how the target quantity objectives will be achieved.

### **Water services**

- Calculate the expected water supply demand at average and peak conditions.
- Calculate the required fire flow as per the Fire Underwriters Survey (FUS) method.
- Confirm the adequacy of water supply and pressure during peak flow and fire flow with the City of Ottawa.



- Describe the proposed water distribution network and connection to the existing system.

### Sanitary services

- Calculate peak flow rates from the development.
- Describe the proposed sanitary system.

## 4 WATER SUPPLY AND FIRE PROTECTION

### 4.1 Existing Water Supply Services and Fire Hydrant Coverage

The subject property lies within the City of Ottawa 4C water distribution network pressure zone. Refer to **Appendix B** for the water network pressure zone map.

The subject property is located within proximity of an existing 406 mm dia. PVC watermain within Bank Street.

There are currently six (6) existing fire hydrants within close proximity to the property:

- 1) West side of Bank Street, approximately 6m North of North P/L
- 2) West side of Bank Street, approximately 93m North of North P/L
- 3) West side of Bank Street, approximately 215m North of North P/L
- 4) West side of Bank Street, approximately 87m South of South P/L
- 5) West side of Bank Street, approximately 202m South of South P/L
- 6) West side of Bank Street, approximately 303m South of South P/L

Refer to **Appendix B** for the location of fire hydrants.

### 4.2 Water Supply Servicing Design

The subject property is proposed to be serviced via 19mm diameter Type K copper service lateral connected to the 406mm diameter PVC watermain located within Bank Street.

Refer to Site Servicing Plan C401 in **Appendix E** for servicing layout.

Table 1 summarizes the City of Ottawa Design Guidelines design parameters utilized in the preparation of the water demand estimate.

**Table 1: City of Ottawa Design Guidelines Design Parameters**

Design Parameter	Value
Industrial – Light Demand	35,000 L/(gross ha)/d
Minimum Depth of Cover	2.4 m from top of watermain to finished grade
Desired operating pressure range during normal operating conditions	345 kPa (50 psi) and 552 kPa (80 psi)
During maximum hourly demand conditions pressure must not drop below	276 kPa (40 psi)
During normal operating conditions pressure shall not exceed	552 kPa (80 psi)
During maximum day and fire flow operating conditions pressure must not drop below	140 kPa (20 psi)

*\*Table updated to reflect technical Bulletin ISDTB-2018-02*



The interior layout and architectural floor plans have been reviewed, and it was determined that the building will include:

- 3 commercial / industrial units (auto service, auto body shop)

The required water supply requirements for the industrial units in proposed building have been calculated using the following formula:

Where:  $Q = (q \times A \times M)$   
 $q$  = average water consumption (L/grossha/day)  
 $A$  = gross area (ha)  
 $M$  = Peak factor

For industrial water demands, the following factors were used in calculations as per Table 4.2 in the Ottawa Design Guidelines – Water Distribution:

- Maximum Daily Demand Commercial Factor = **1.5**
- Peak Hour Demand Commercial Factor = **1.8**

For a site with an approximate area of **0.172** ha, the industrial anticipated demands were calculated as follows:

- Average daily domestic water demand is **0.069** L/s,
- Maximum daily demand is **0.103** L/s, and
- Maximum hourly is **0.186** L/s.

Refer to **Appendix B** for water demand calculations.

The City of Ottawa was contacted to obtain boundary conditions associated with the estimated water demand, as indicated in the boundary request correspondence included in **Appendix B**. Table 2 below summarizes boundary conditions for the proposed development.

**Table 2: Summary of Anticipated Demands and Boundary Conditions**

Design Parameter	Anticipated Demand (L/s)	Boundary Conditions @ Bank Street Head (m) / Pressure (psi)
Average Daily Demand	0.069	165.2 / 74.3
Max Day + Fire Flow (per FUS)	0.103 + 100.0	155.2 / 60.1
Peak Hour	0.186	159.9 / 66.8
* Assumed Ground elevation at connection point = 112.93 m.		
Water demand calculation per City of Ottawa Water Design guidelines. See Appendix B for details.		

As shown above, pressures from boundary conditions exceed the minimum required threshold in all scenarios.



The estimated fire flow for the proposed buildings was calculated in accordance with *ISTB-2018-02*. The following parameters were provided by the Architect, see **Appendix A** for collaborating correspondence:

- Type of construction – Ordinary Construction
- Occupancy type – Combustible
- Sprinkler Protection – No sprinkler system

The estimated fire flow demand was estimated to be **6,000 L/min**, see **Appendix B** for details.

There are six (6) existing fire hydrants in close proximity to the proposed buildings that are available to provide the required fire flow demands of 6,000 L/min. Refer to **Appendix B** for fire hydrant locations.

Table 3 below summarizes the contributing hydrants within close proximity (equal to or less than 305m) to the proposed development based on Table 18.5.4.3 of *ISTB-2018-02*.

**Table 3: Fire Protection Summary Table**

Building	Fire Flow Demand (L/min)	Fire Hydrants(s) within 76m	Fire Hydrant(s) within 152m	Fire Hydrant(s) within 305m
Proposed Commercial Building	6000	1	2	3

As the fire hydrants listed above all pull from the same watermain, a drop in pressure is expected when pulling from multiple hydrants. The total available fire flow from contributing hydrants will need to be established by the City of Ottawa through a multi-hydrant analysis.

## 5 SANITARY SERVICE

### 5.1 Existing Sanitary Sewer Services

There is no sanitary sewer located within Bank Street. The sanitary outflows produced by the current site are treated by a septic system, and release via leaching bed.

The existing septic system will need to be removed. Removal of the existing system will require approval by the OSSO.

### 5.2 Sanitary Sewer Servicing Design

The proposed development will be serviced via a septic treatment system and leaching bed, to be buried at the rear (west) of the property.

The parameters to be used to calculate the anticipated sanitary flows are:

- A commercial/industrial lot space / gross area of 0.172ha



- A light industrial flow of 35,000 L/ha/day
- An industrial peaking factor of 7.0
- a total infiltration rate of 0.33 L/s/ha

Based on these parameters the total anticipated wet sanitary flow was estimated to be **0.54 L/s**. Refer to LRL drawing C401 in **Appendix E** for the proposed sanitary servicing.

Refer to **Appendix C** for the site sanitary sewer design sheet.

The septic system design is to be performed by an accredited septic designer.

## 6 STORMWATER MANAGEMENT

### 6.1 Existing Stormwater Infrastructure

Stormwater runoff from the subject property is tributary to the City of Ottawa stormwater management system. As such, approvals for the proposed development within this area are under the approval authority of the City of Ottawa.

In pre-development conditions, stormwater from a small portion of the front (East) of the property will flow uncontrolled overland to the Bank Street roadside ditch. The balance of the site's stormwater flows uncontrolled overland to the West & South property lines.

Refer to **Appendix E** for pre-development watershed information.

### 6.2 Design Criteria

The stormwater management criteria for this development are based on the pre-consultation with City of Ottawa officials, the City of Ottawa Sewer Design Guidelines including City of Ottawa Stormwater Management Design Guidelines, 2012 (City standards), as well as the Ministry of the Environment's Stormwater Planning and Design Manual, 2003 (SWMPD Manual).

#### 6.2.1 Water Quality

The proposed development lot is subject to review by the City of Ottawa. It was determined that site stormwater management quality criteria for the site will follow the City's requirements; 80% TSS removal (based on MOE fine PSD).

Stormwater quality requirements have been met by incorporating a treatment unit within the stormwater network, the Stormceptor EFO4 stormwater treatment unit (or approved equivalent). Supporting calculations for TSS removal can be found in **Appendix D**.

In due course, an agreement for ongoing maintenance between the owner and the servicing company will be required to be witnessed by the City.

Correspondence (pre-application consultation meeting minutes) with municipal input is included in **Appendix A**.



Quality treatment unit details have been included within **Appendix D**.

### 6.2.2 Water Quantity

Based on pre-consultation discussions with the City of Ottawa and South Nation Conservation Authority, correspondence included in **Appendix A**, the following stormwater management requirements were identified for the subject site:

- Meet an allowable release rate based on the existing Rational Method Coefficient of no more than 0.50, employing the City of Ottawa IDF parameters for a 2-year storm with a calculated time of concentration equal to or greater than 10 minutes.
- Attenuate all storms up to and including the City of Ottawa 100-year storm event on site.

The allowable release rate for the subject site was calculated to be **24.77 L/s**.

Refer to **Appendix D** for calculations.

### 6.3 Method of Analysis

The Modified Rational Method has been used to calculate the runoff rate from the site to quantify the detention storage required for quantity control of the development.

Refer to **Appendix D** for storage calculations.

### 6.4 Proposed Stormwater Quantity Controls

The extent of the stormwater management quantity control calculations will focus on the proposed development and the proposed changes to the site. The proposed changes to the site are as follows;

- 3 unit building development
- Paved driveway, sidewalk/curbs and parking lot
- Grassed area and planters
- Retaining wall bordering South property line

The balance of the site unaffected by these works will remain as they were in existing condition.

The existing site is delineated by catchment EWS-01 (0.172 ha), consisting of buildings, both asphalt and gravel paving, and grassed area (total runoff coefficient of 0.58). Off-site runoff to be considered within the stormwater management design have been delineated within catchment areas EWS-02 and EWS-03. Catchment EWS-02 (0.024ha) consists of runoff coming from the existing driveway and grassed area within the municipal property. Catchment area EWS-03 (0.036ha) consists of runoff from grass areas coming from the north neighboring property.

Refer to **Appendix E** Civil Plan C701 for greater detail.

The proposed stormwater management quantity control for this development will be accomplished by restricting flow leaving site via a flow control at the outlet of the stormwater management network; a Hydrovex 100VHV-1 Flow Control Device (or approved equivalent). Storage required as a result of quantity control measures will be accomplished by minor surface ponding, but mostly



via underground storage chambers. Stormwater will be captured by one of the proposed catch basins within the driveway, controlled/stored, conveyed to the treatment unit and ultimately pumped up to the Bank Street roadside ditch.

The proposed site storm sewer and stormwater management system are shown on drawing C401 and detailed calculations, including the design sheet, can be found in **Appendix D**.

The proposed site development has been analyzed and post development watersheds have been allocated.

- Watershed WS-01 (0.083 ha), consisting of the east and central portions of the driveway and parking lot, some off-site runoff from the grassed area to the north, as well as 2 bay rooftops, will be captured by CBMH02
- Watershed WS-02 (0.047 ha), consisting of mostly the asphalt driveway cul-de-sac, 1 bay rooftop and surrounding grass area, as well as some off-site runoff from the grassed area to the north, will be captured by catch basin CB01.
- Watershed WS-03 (0.102 ha), consisting of the west grassed portion of the site and property line buffers, as well as off-site runoff from the grassed hill to the north, will flow overland off site uncontrolled, as it did in pre-development conditions

Table 4 below summarizes post-development drainage areas. Detailed calculations can be seen in **Appendix D**.

**Table 4: Post Development Drainage Areas**

Catchment Area	Area (ha)	Weighted Runoff Coefficient (C)	100 Year Weighted Runoff Coefficient (25% increase)
WS-01 (controlled)	0.083	0.71	0.89
WS-02 (controlled)	0.047	0.72	0.90
WS-03 (uncontrolled)	0.102	0.20	0.25

Table 5 below summarizes the release rates and storage volumes required to meet the allowable release rate of **24.77 L/s** for 100-year flow.



**Table 5: Stormwater Release Rate & Storage Volume Summary (100 Year)**

Catchment Area	Drainage Area (ha)	100-year Release Rate (L/s)	100-Year Required Storage (m <sup>3</sup> )	Total Available Storage (m <sup>3</sup> )
WS-01, WS-02 (controlled via ICD)	0.130	12.00*	43.67**	44.39
WS-03 (uncontrolled)	0.102	12.66	0.00	0.00
<b>TOTAL</b>	<b>0.232</b>	<b>24.66</b>	<b>43.67</b>	<b>44.39</b>

\*proposed controlled release rate using flow control unit

\*\*as stormwater storage is occurring underground, the controlled release rate was halved to 6.00 L/s for storage volume calculations

The 100-year maximum ponding depths can be found on drawing “C601 – Stormwater Management Plan” of **Appendix E**.

## 7 EROSION AND SEDIMENT CONTROL

During construction, erosion and sediment controls will be provided primarily via a sediment control fence to be erected along the perimeter of the site where runoff has the potential of leaving the site. Inlet sediment control devices are also to be provided in any catch basin and/or manholes in and around the site that may be impacted by the site construction. Construction and maintenance requirements for erosion and sediment controls are to comply with Ontario Provincial Standard Specification OPSS 577.

Refer to drawing C101 in **Appendix E** for erosion and sediment control details.

## 8 CONCLUSION

This Stormwater Management and Servicing Report for the development proposed at 5254 Bank Street presents the rationale and details for the servicing requirements for the subject property.

In accordance with the report objectives, the servicing requirements for the development are summarized below:

### Water Service

- The maximum required fire flow was calculated at **6,000 L/min** using the FUS method.
- There are six (6) existing fire hydrants within close proximity to the proposed development. As the hydrants follow the same watermain, the city will need to provide a multi-hydrant analysis to confirm adequate fire flow can be provided.



- The proposed building will be serviced by one (1) new connection: a new 19 mm diameter water service to be connected to the existing 406 mm diameter watermain within Bank Street.
- Boundary conditions received from the City of Ottawa indicate that sufficient pressure is available to service the proposed site.

### Sanitary Service

- The anticipated sanitary flow from the proposed development is **0.54 L/s**.
- The proposed development will be serviced by a septic treatment train and leaching bed (design by others).

### Stormwater Management

- Stormwater quality controls require a minimum 80% TSS removal, which will be achieved by the proposed stormwater treatment unit.
- The storm water release rates from the proposed development will meet calculated allowable release rate of **24.77 L/s**.
- Stormwater quantity control objectives will be met through overland ponding and underground storage structures, and control will be provided via the flow control unit proposed.

## 9 REPORT CONDITIONS AND LIMITATIONS

The report conclusions are applicable only to this specific project described in the preceding pages. Any changes, modifications or additions will require a subsequent review by LRL Associates Ltd. to ensure the compatibility with the recommendations contained in this document. If you have any questions or comments, please contact the undersigned.

Prepared by:  
**LRL Associates Ltd.**



Mohan Basnet, P. Eng.  
Civil Engineer

A handwritten signature in black ink, appearing to read "Kyle Herold".

Kyle Herold  
Civil Designer



**APPENDIX A**  
**Pre-consultation / Correspondance**



## Pre-Application Consultation Meeting Notes

**Property Address:** 5254 Bank Street, Ottawa, ON  
Pre-Application Consultation File Number PC 2022 0103  
Date: May 17, 2022 Room: Virtual

**Attendees:** Sam Cox (Agent), Cheryl McWilliams, Damien Whittaker, Jasdeep Brar

**Regrets:** Mike Giampa

**Subject:** 5254 Bank Street

### Meeting notes:

#### Opening & attendee introduction

- Introduction of meeting attendees
- Overview of proposal:
  - Applicant is proposing to remove the holding provision along with a zoning by-law amendment to build a new 619m structure for light industrial and personal services use.
  - The current zone is RG3 [900R]-h Rural General Industrial.
  - The applicant is seeking minor variances for parking provisions, the front yard setback, and the southern interior side yard setback.
  - Two of the smaller bays are proposed for personal service use, two medium sized bays are proposed for “automobile repair” and the larger bay reserved for the owner for “automobile repair” use.
- Projected timing including construction – not specified

#### Preliminary comments and questions from staff and agencies, including follow-up actions:

- Planning
  - Proposed Minor Variances may not be eligible as the zoning amendment by-law 2021-286 was passed last year, ***will follow up to determine applicability***
  - Committee of Adjustment / variances required
  - The property neighbours lands designated as sand and gravel resources and is in close proximity to a licensed quarry across Bank Street. As per Section 3.7.4 of the City of Ottawa Official Plan, sensitive land uses will not be approved within 300 metres of a Sand and Gravel Resource Area and 500 metres of a bedrock resource area, unless it can be demonstrated that such development will not conflict with future mineral aggregate extraction. Personal service businesses are considered a sensitive land use with respect to pits and quarries.
- Urban Design
  - As per Schedule C13 of the City of Ottawa Official plan, Bank Street is a Scenic Entry Route Policy 4.6.4 of the new City of Ottawa Official Plan aims to ensure that development abutting Scenic Routes contributes to conserving or creating a desirable context by means such as

- b. Preserving and restoring landscaping, including but not limited to distinctive trees and vegetation along the right of way,
- c. Orienting buildings towards the Scenic Route and providing direct pedestrian access, where appropriate; and
- d. Providing screening by way of opaque fencing or landscape buffers to hide surface parking lots or outside storage; and
- e. Managing the intensity and spill-over of lighting on adjacent parcels.

As such, tree buffering of parking areas is needed. Consider increasing the number of windows (double of what is proposed) to enhance the front façade and to add more windows or protected openings on the south façade facing or in proximity to Bank street.

- Engineering

- Development density;
  - As stated for the re-zoning of the property it will be a challenge to develop the property and staff opposed the application; developing with a very high lot coverage makes a challenging site much, much harder
- Surveying;
  - Civil engineering plans shall have a note that references the horizontal and vertical datums that were used, and tied into, to complete the project.
  - The drawing should also make reference (on the face of the plan) to a site benchmark that can be used by anyone with a level to carry out checks on the particular project..
- Water pipes:
  - There is a municipal water pipe near the application, though there may not be fire-fighting provision at the address. Please have the civil consultant provide a Water Boundary Conditions request (please note that fixture counts should not be used) for further site applications at this stage.” The fire demand shall be calculated by the FUS methodology (2020) and if a construction coefficient less than 1 is proposed that a waiver will be required and the necessary componentry/design shall be demonstrated and a commence work notice shall not be provided until satisfactory assurance is given to an engineering member of the Rural Development Review unit.
- Sanitary Sewers:
  - There are no municipal sanitary sewers adjacent to the property
- Terrain Analysis:
  - As there are no municipal sanitary sewers adjacent the property a septic system will be needed. A terrain analysis will be needed to design the septic system and the approval from the OSSO will be needed before site plan approval is given. Please also note that thin soils may exist in the area and increased (non-standard) septic treatment is anticipated.
- Geotechnical
  - Please note that sensitive marine clays are anticipated in the area of the proposal and, if so, enhanced geotechnical investigation and analysis will be necessary. Investigation of clays should be undertaken with vane

shear, Atterberg limits, shrinkage, size, grade raise restriction, consolidation, sensitivity, and liquefaction analysis- amongst others. Further, to maintain the desired result of the trees in clay soils policy all of the conditions of the policy need to be met.

- Please note that the 2.1 m of cover in the vicinity of the footings is sometimes a challenge as is the necessary comprehensive linkages between geotechnical, grading, parks, utilities, and trees. Thin soils exist in the area and enhanced geotechnical investigation and analysis will be necessary.
- Hydrogeological
  - A hydrogeological report may be required if a SWM pond, or similar stormwater management infrastructure, is proposed
- Storm Sewers:
  - No storm sewers exist in the area and instead there are ditches. The consultant will need to show and/or provide continuation of ditch flows.
- Groundwater:
  - Groundwater is anticipated to be high and the level is to be derived from long-term analysis (12 months, or more) or spring freshet conditions ((unfrozen ground and significant rainfall). With the high groundwater anticipated, the City advises against basements for the development.
- Noise and vibration:
  - A noise report will be required for the traffic from Bank Street, recorded on Official Plan Schedule G as an existing arterial.
- Mineral Resource Impact Assessment
  - Due to the personal service options being included a Mineral Resource Impact Assessment (MRIA) will be required- please note that removing the personal service option may not negate the need.
- Storm Water Management:
  - Stormwater management quality criteria shall follow the SNRCA's requirements- anticipated to be for 80% TSS removal. The quantity criteria for the development is that 100-year post-development shall match 2-year pre-development. LID is required as per the memo from the former MOECC (now MECP). Any existing stormwater runoff from adjacent site(s) that crosses the property must be accommodated by the proposed stormwater management design. All stormwater management determinations shall have supporting rationale. The stormwater management report shall itemize concurrence with the content

of the updated (2004) Shields Creek Subwatershed Study, as shown by Annex 2B;

- a. Thermally controlled low flow in summer, to a maximum of 23 degrees Celsius is required for an anticipated coldwater habitat (p. 6-13, sheet 114) (p. 4-53, sheet 73). It is not sufficient to merely have a bottom draw outlet.
- b. 150 mm/yr infiltration (table 5.5.1, p.5-5, sheet 84) (figure 4.3.4, sheet 201) A pollution prevention/spill control report is required as per section 6.3.4.8 of the SCSWS.
- Roads:
  - The required ROW at the location, according to Annex 1 of the Official Plan is 40 m.
- Site lighting:
  - Lighting must be designed only using fixtures that meet the criteria for Full Cut-off classification, as recognized by the Illuminating Engineering Society of North America (IESNA or IES), and it must result in minimal light spillage onto adjacent properties; 0.5 foot-candles is the maximum allowable spillage.
- Phase 2 ESA:
  - A Phase 2 ESA is required following the previously completed Phase 1 ESA.
- Energy Conservation:
  - Energy conservation is required to be demonstrated throughout design as per section 4.9 of the Official Plan.

Questions regarding the above requirements can be directed to Senior Engineer Infrastructure Applications, [damien.whittaker@ottawa.ca](mailto:damien.whittaker@ottawa.ca)

- Transportation
  - Parking requirements
    - To determine the number of required parking spaces, further clarification is required regarding the proposed “light industrial use” and whether it classifies as “Automobile Service Station” or as a “Service and Repair Shop” in Section 54 of Zoning By-law 2008-25
    - If the use classifies as “Automobile Service Station”, further clarification required on the number of service bays to determine parking requirements
  - TIA submission / Road modification agreement requirements
    - A Transportation Impact Assessment is not required and therefore that condition of the lifting of the holding provision can be waived based on the current concept site plan and uses.

- Cycling and pedestrian
  - Required ROW width
    - Bank Street has a protected right of way of 40 m, or 20 m from the centreline, That will need to be demonstrated on the survey
- Noise report
  - A noise report may be required for the traffic from Bank Street, recorded on Official Plan Schedule G as an existing arterial. This may be waived if no sensitive land uses are proposed.
- Environmental
  - Tree preservation / distinctive trees – Tree Conservation Report required as part of Landscape plan
- Parks
  - Cash-in-lieu of parkland per the Parkland Dedication By-law (2% of the value of the land prior to site plan approval)
- Survey
  - The determination of property boundaries, minimum setbacks and other regulatory constraints are a critical component of development. An Ontario Land Surveyor (O.L.S.) needs to be consulted at the outset of a project to ensure properties are properly defined and can be used as the geospatial framework for the development.
  - Topographic details may also be required for a project and should be either carried out by the O.L.S. that has provided the Legal Survey or done in consultation with the O.L.S. to ensure that the project is integrated to the appropriate control network.

Questions regarding the above requirements can be directed to the City's Surveyor, Bill Harper, at [Bill.Harper@ottawa.ca](mailto:Bill.Harper@ottawa.ca)

- Conservation Authority - South Nations Conservation Authority
  - The site falls within the Shield Creek Sub watershed Study and SNC would request the 80% TSS removal for runoff quality treatment.
  - SNC recommends that the OSSO review design flows, contact areas and setbacks for a septic system to ensure that a OBC Part 8 permit can be issued down the road.
  - It is unclear whether the roadside ditch would constitute a watercourse or how the stormwater design may function. Any interference with a watercourse may require a permit under O. Reg. 170/06 and restrictions may apply. It is unlikely for this property and South Nation Conservation will confirm at the detail design stage.
- Permits and Approvals
  - Please contact the South Naiton Conservation Authority (SNRCA), amongst other federal and provincial departments/agencies, to identify all the necessary permits and approvals required to facilitate the development: responsibility rests

with the developer and their consultant for determining which approvals are needed and for obtaining all external agency approvals. The address shall be in good standing with all approval agencies, for example MVCA, prior to approval. Copies of confirmation of correspondence will be required by the City of Ottawa from all approval agencies that a form of assent is given. No construction shall commence until after a commence work notification is given by and engineering member of the Rural Development Review unit. An MECP ECA may be required for the application; please also note that by the time the ECA is applied for, with this application, that a different type of process may be underway.

Ministry of the Environment, Conservation and Parks	South Nation River Conservation Authority
Contact Information:	Contact Information:
Jena Leavoy	James Holland
Senior Environmental Officer	<a href="mailto:jholland@nation.on.ca">jholland@nation.on.ca</a>
613-521-3450 ext. 236	
<a href="mailto:Jena.Leavoy@ontario.ca">Jena.Leavoy@ontario.ca</a>	

### Submission requirements and fees

- Outline the submission requirements and fees.
  - Submission requirements for planning
    - Landscape plan including Tree Conservation Report (boundary trees and any on-site trees need to be considered)
    - Site Plan (including zoning chart)
    - a planning rationale – at minimum as a cover letter
    - Phase 1 and 2 ESA
    - Building Elevations.
  - Submission requirements for engineering
    - Site Servicing Plan\*
    - Grading and Drainage Area Plan\*
    - Erosion and Sediment Control Plan\*
    - Site Servicing Report to be prepared as per requirements.
    - Storm Water Management Report
    - Noise Report
    - Erosion and Sediment Control Measures
    - Mineral Resource Impact Assessment
    - Geotechnical Investigation Study
      - The geotechnical consultant will need to provide full copies of any published and peer reviewed papers relied on to determine results and conclusions
      - Earthquake analysis is now required to be provided in the report.
    - Phase 2 Environmental Site Assessment (ESA)
      - The Phase 2 Environmental Site Assessment (ESA) shall be as per O.Reg. 153/04. Phase 1 ESA documents performed to CSA standards

are not acceptable. Documents older than 18 months from the time of draft approval will not be accepted

- Guide to preparing City of Ottawa Studies and Plans: <http://ottawa.ca/en/development-application-review-process-0/guide-preparing-studies-and-plans>

To request City of Ottawa plan(s) or report information please contact the ISD Information Centre:  
Information Centre  
(613) 580-2424 ext. 44455

- Additional information regarding fees related to planning applications can be found [here](#).
- \*Plans are to be standard A1 size (594 mm x 841 mm) sheets, utilizing an appropriate Metric scale (1:200, 1:250, 1:300, 1:400 or 1:500) as per City of Ottawa Servicing and Grading Plan Requirements and shall note the survey monument used to establish datum on the plans with sufficient information to enable a layperson to locate the monument.
- All PDF submitted documents are to be unlocked and flattened.

### **Next steps**

- Encourage applicant to discuss the proposal with Councillor, community groups and neighbours
- Any questions on the notes or submission requirements let us know.

CLM/JB

**APPENDIX B**  
**Water Supply Calculations**





**LRL File No.** 220536-03  
**Project:** Commercial Development  
**Location:** 5254 Bank Street, Ottawa  
**Date:** April 2, 2024  
**Designed:** K.Herold

**Water Demand**  
 (Based on City of Ottawa Design Guidelines  
 - Water Distribution, 2010)

**Commercial / Industrial Demand**

Unit Type	Unit Rate	Area (ft <sup>2</sup> )	Area (ha)	Demand (L/d)
Service/Repair Shop (Industrial-Light)	35000 L/(grossha)/d	18331.0	0.17	5960.3
			<b>0.17</b>	<b>5960.3</b>

**Commercial / Industrial Consumption Rates**

Unit Type	Value	Units	Value	Units
<b>Average Daily Demand</b>	<b>5,960</b>	<b>L/d</b>	<b>0.069</b>	<b>L/s</b>
Maximum Daily Factor	1.5	<i>(Design guidelines - water distribution Table 4.2)</i>		
<b>Maximum Daily Demand</b>	<b>8,940</b>	<b>L/d</b>	<b>0.103</b>	<b>L/s</b>
Peak Hour Factor	1.8	<i>(Design guidelines - water distribution Table 4.2)</i>		
<b>Maximum Hour Demand</b>	<b>16,093</b>	<b>L/d</b>	<b>0.186</b>	<b>L/s</b>

**Total Demand**

Demand	Value	Units	Value	Units
<b>Average Daily Demand</b>	<b>5,960</b>	<b>L/d</b>	<b>0.069</b>	<b>L/s</b>
<b>Maximum Daily Demand</b>	<b>8,940</b>	<b>L/d</b>	<b>0.103</b>	<b>L/s</b>
<b>Maximum Hourly Demand</b>	<b>16,093</b>	<b>L/d</b>	<b>0.186</b>	<b>L/s</b>

**Water Service Pipe Sizing**

Q = VA	Q = Flow Rate	V = Velocity	A = Area of pipe
Assumed maximum velocity =	1.8	m/s	

Q = 0.19 L/s  
 Q = 0.00019 m<sup>3</sup>/s

Minimum pipe diameter (d) =  $(4Q/\pi V)^{1/2}$   
 = 0.011 m  
 = 11 mm

Proposed pipe diameter (d) = **19 mm**  
**3/4 in**



## Pipe Pressure Losses Calculations

LRL File No. 220536-03

Project Commercial Development

Location: 5254 Bank Street, Ottawa

Date 2024-04-02

Designed: K. Herold

### Piezometric Head Equation (Derived from Bernoulli's Equation)

$$h = \frac{p}{\gamma} + z$$

Where:

h = HGL (m)

p = Pressure (Pa)

γ = Specific weight (N/m<sup>3</sup>) =

9810

z = Ground Elevation (m) =

112.93

Water Pressure on Huron Street			
HGL (m)		Pressure	
		kPa	psi
Minimum =	159.9	460.78	66.83
Maximum =	165.2	512.77	74.37
Max. Day + Fire =	155.2	414.67	60.14

### Hazen Williams Equation

$$h_f = \frac{10.67 \times Q^{1.85} \times L}{C^{1.85} \times d^{4.87}}$$

Where:

h<sub>f</sub> = Head loss over the length of pipe (m)

Q = Volumetric flow rate (m<sup>3</sup>/s)

L = Length of pipe (m)

C = Pipe roughness coefficient

d = Pipe diameter (m)

### Scenario 1: maximum daily demand

Q (L/s)	0.103
C	150

L (m.)	39.5	
I.D. (mm)	19	
V (m/s)	0.36	
$h_f$ (m)	0.41	
Head Loss (psi)	0.58	
Min. Pressure (psi)	66.25	
Max. Pressure (psi)	73.79	
Service Obv. @ Street Connection (m)	110.53	
Service Obv. @ Building Connection (m)	111.60	
Pressure Adjustment (psi)	-1.52	(due to service elev. Diff. from street to building)
Adjusted Min. Pressure (psi)	64.73	(must not be less than 50psi)
Adjusted Max. Pressure (psi)	72.27	(must not be more than 80psi)

### Scenario 2: maximum hourly demand

Q (L/s)	0.186	
C	150	
L (m.)	39.5	
I.D. (mm)	19	
V (m/s)	0.66	
$h_f$ (m)	1.21	
Head Loss (psi)	1.71	
Min. Pressure (psi)	65.12	
Max. Pressure (psi)	72.66	
Service Obv. @ Street Connection (m)	110.53	
Service Obv. @ Building Connection (m)	111.60	
Pressure Adjustment (psi)	-1.52	(due to service elev. Diff. from street to building)
Adjusted Min. Pressure (psi)	63.59	(must not be less than 40psi)
Adjusted Max. Pressure (psi)	71.14	(must not be more than 80psi)

## Boundary Conditions 5254 Bank Street

### Provided Information

Scenario	Demand	
	L/min	L/s
Average Daily Demand	4.14	0.069
Maximum Daily Demand	6.18	0.103
Peak Hour	11.16	0.186
Fire Flow Demand # 1	6000	100.0

### Location



### Results

#### Connection 1 – Bank Street

Demand Scenario	Head (m)	Pressure <sup>1</sup> (psi)
Maximum HGL	165.2	74.3
Peak Hour	159.9	66.8
Max Day plus Fire #1	155.2	60.1

<sup>1</sup> Ground Elevation = 112.93 m

## **Notes**

*The boundary condition information is based on current operation of the city water distribution system. The computer model simulation is based on the best information available at the time. The operation of the water distribution system can change on a regular basis, resulting in a variation in boundary conditions. The physical properties of watermains deteriorate over time, as such must be assumed in the absence of actual field test data. The variation in physical watermain properties can therefore alter the results of the computer model simulation. Fire Flow analysis is a reflection of available flow in the watermain; there may be additional restrictions that occur between the watermain and the hydrant that the model cannot take into account.*



**LRJ**

ENGINEERING | INGÉNIERIE

5430 Canotek Road | Ottawa, ON, K1J 9G2  
www.lrl.ca | (613) 842-3434

PROJECT

PROPOSED MULTI-UNIT  
COMMERCIAL DEVELOPMENT  
5254 BANK STREET, OTTAWA

DRAWING TITLE

EXISTING FIRE HYDRANTS  
(GEOOTTAWA)

CLIENT

UNPOISED ARCHITECTURE INC.

DATE

DEC142022

PROJECT

220536-01

**C000**



# **APPENDIX C**

## **Wastewater Collection Calculations**





# **APPENDIX D**

## **Stormwater Management Calculations**



LRL Associates Ltd.  
Storm Watershed Summary



**LRL File No.** 220536-04  
**Project:** Multi-Unit Commercial Dev.  
**Location:** 5254 Bank Street  
**Date:** June 27, 2025  
**Designed:** K. Herold  
**Checked:** M. Basnet  
**Drawing Reference:** C.701, C.702

**Pre-Development Catchments**

WATERSHED	C = 0.20	C = 0.80	C = 0.90	Total Area (ha)	Combined C
EWS-01	0.075	0.020	0.077	0.172	0.58
EWS-02	0.016	0.000	0.008	0.024	0.43
EWS-03	0.036	0.000	0.000	0.036	0.20
<b>TOTAL</b>	<b>0.127</b>	<b>0.020</b>	<b>0.085</b>	<b>0.232</b>	<b>0.51</b>

**Post-Development Catchments**

WATERSHED	C = 0.20	C = 0.80	C = 0.90	Total Area (ha)	Combined C
WS-01*	0.023	0.000	0.060	0.083	0.71
WS-02**	0.012	0.000	0.035	0.047	0.72
<b>TOTAL CONTROLLED</b>	<b>0.035</b>	<b>0.000</b>	<b>0.095</b>	<b>0.130</b>	<b>0.71</b>
WS-03***	0.102	0.000	0.000	0.102	0.20
<b>TOTAL UNCONTROLLED</b>	<b>0.102</b>	<b>0.000</b>	<b>0.000</b>	<b>0.102</b>	<b>0.20</b>
<b>TOTAL</b>	<b>0.137</b>	<b>0.000</b>	<b>0.095</b>	<b>0.232</b>	<b>0.49</b>

\*WS-01 will be taking on 0.012 (C = 0.20) & 0.014 (C = 0.90) ha of off-site runoff which will be taken in and controlled

\*\*WS-02 will be taking on 0.002ha (C = 0.20) of off-site runoff which will be taken in and controlled

\*\*\*WS-03 will be taking into consideration 0.032ha (C=0-20) of off-site uncontrolled runoff



LRL File No. 220536-04  
 Project: Multi-Unit Commercial Dev.  
 Location: 5254 Bank Street  
 Date: June 27, 2025  
 Designed: K. Herold  
 Checked: M. Basnet  
 Drawing Ref.: C.401

Stormwater Management  
 Design Sheet

**STORM - 100 YEAR**

**Runoff Equation**

$Q = 2.78CIA$  (L/s)  
 C = Runoff coefficient  
 $I = \text{Rainfall intensity (mm/hr)} = A / (Td + C)^B$   
 A = Area (ha)  
 T<sub>c</sub> = Time of concentration (min)

**Pre-Development Catchments within Development Area**

	Total Area =	0.232	ha	$\bar{C}R =$	0.51
Un-Controlled	EWS-01, 02, 03	0.232	ha	R =	0.51
	Total Uncontrolled =	0.232	ha	$\bar{C}R =$	0.51

**Allowable Release Rate (Max C=0.5, 2-year Pre-Dev FR)**

2 Year Pre-Development Flow Rate

$I_2 = 732.951 / (Td + 6.199)^{0.81}$       **A = 732.951**      **B = 0.81**      **C = 6.199**

C = 0.50 the smaller of 0.5 or the actual existing as per the City of Ottawa  
 I = 76.8 mm/hr  
 T<sub>c</sub> = 10 min  
 Total = 0.232 ha  
 Site Total Allowable Release Rate = **24.77** L/s

**Post-development Stormwater Management**

	Total Site Area =	0.232	ha	$\bar{C}R =$	0.49	$\bar{C}R_{100} =$	0.61
Controlled	Total Controlled =	0.130	ha	$\bar{C}R =$	0.71	$\bar{C}R_{100} =$	0.89
Un-controlled	Total Uncontrolled =	0.102	ha	$\bar{C}R =$	0.20	$\bar{C}R_{100} =$	0.25

**Post-development Stormwater Management**

$I_{100} = 1735.688 / (Td + 6.014)^{0.80}$       **A = 1735.688**      **B = 0.82**      **C = 6.014**

Time (min)	Intensity (mm/hr)	Controlled Runoff* (L/s)	Storage Volume (m <sup>3</sup> )	Controlled Release Rate (L/s)	Uncontrolled Runoff (L/s)	Total Release Rate (L/s)
10	178.6	57.40	27.24	12.00	12.66	24.66
15	142.9	45.93	30.54	12.00	10.13	22.13
20	120.0	38.56	31.87	12.00	8.50	20.50
25	103.8	33.38	32.07	12.00	7.36	19.36
30	91.9	29.53	31.55	12.00	6.51	18.51
35	82.6	26.54	30.54	12.00	5.85	17.85
40	75.1	24.15	29.17	12.00	5.33	17.33
45	69.1	22.20	27.53	12.00	4.89	16.89
50	64.0	20.56	25.67	12.00	4.53	16.53
55	59.6	19.17	23.65	12.00	4.23	16.23
60	55.9	17.97	21.48	12.00	3.96	15.96
65	52.6	16.92	19.20	12.00	3.73	15.73
70	49.8	16.00	16.82	12.00	3.53	15.53
75	47.3	15.19	14.35	12.00	3.35	15.35
80	45.0	14.46	11.82	12.00	3.19	15.19

**Post-development Stormwater Management**

$I_{100} = 1735.688 / (Td + 6.014)^{0.80}$       **a = 1735.688**      **b = 0.82**      **C = 6.014**  
 \* for volume calculation, controlled release rate taken as half of the max. discharge rate

Time (min)	Intensity (mm/hr)	Controlled Runoff* (L/s)	Storage Volume (m <sup>3</sup> )	Controlled Release Rate (L/s)	Uncontrolled Runoff (L/s)	Total Release Rate (L/s)
10	178.6	57.40	30.84	6.00	12.66	18.66
15	142.9	45.93	35.94	6.00	10.13	16.13
20	120.0	38.56	39.07	6.00	8.50	14.50
25	103.8	33.38	41.07	6.00	7.36	13.36
30	91.9	29.53	42.35	6.00	6.51	12.51
40	75.1	24.15	43.57	6.00	5.33	11.33
50	64.0	20.56	43.67	6.00	4.53	10.53
60	55.9	17.97	43.08	6.00	3.96	9.96
75	47.3	15.19	41.35	6.00	3.35	9.35
90	41.1	13.21	38.96	6.00	2.91	8.91
105	36.5	11.73	36.11	6.00	2.59	8.59
120	32.9	10.57	32.93	6.00	2.33	8.33
135	30.0	9.64	29.50	6.00	2.13	8.13
150	27.6	8.88	25.88	6.00	1.96	7.96
165	25.6	8.23	22.09	6.00	1.82	7.82

**Onsite Stormwater Retention**

Total Storage Required = 43.67 m<sup>3</sup>  
 Underground Storage = 43.95 m<sup>3</sup> refer to LRL Plan C401, C601  
 Surface Storage = 0.44 m<sup>3</sup> refer to LRL Plan C401, C601  
 Total Available Storage = 44.39 m<sup>3</sup>

LRL Associates Ltd.  
Storm Design Sheet



**LRL File No.** 220536-04  
**Project:** Multi-Unit Commercial Dev.  
**Location:** 5254 Bank Street  
**Date:** June 27, 2025  
**Designed:** K. Herold  
**Checked:** M. Basnet  
**Drawing Reference:** C.401

Rational Method  $Q = 2.78CIA$   
 Q = Peak flow in litres per second (L/s)  
 A = Drainage area in hectares (ha)  
 C = Runoff coefficient  
 I = Rainfall intensity (mm/hr)

**Storm Design Parameters**

Runoff Coefficient (C)  
 Grass 0.20  
 Gravel 0.80  
 Asphalt / rooftop 0.90

Ottawa Macdonald-Cartier International Airport IDF curve equation (2 year event, intensity in mm/hr)  
 $I = 732.951 / (T_c + 6.199)^{0.81}$   
 Min. velocity = 0.80 m/s  
 Manning's "n" = 0.013

LOCATION			AREA (ha)			FLOW					STORM SEWER							MANHOLE								
WATERSHED / STREET	From MH	To MH	C = 0.20	C = 0.80	C = 0.90	Indiv. 2.78AC	Accum. 2.78AC	Time of Conc. (min.)	Rainfall Intensity (mm/hr)	Peak Flow Q (l/s)	Pipe Diameter (mm)	Type	Slope (%)	Length (m)	Capacity Full (L/s)	Velocity Full (m/s)	Time of Flow (min.)	Ratio (Q/Q <sub>FULL</sub> )	Up Invert (m)	Down Invert (m)	T/G Up Stream (m)	T/G Down Stream	Up Depth obv (m)	Down Depth obv (m)	Up Depth inv (m)	
WS-02	CBMH02	CBMH03	0.012	0.000	0.035	0.09	0.09	10.00	76.81	7.24																
WS-02 will be taking on 0.002 (C = 0.20) of off-site runoff which will be taken in and controlled																										
WS-01	CBMH02	PUMP	0.023	0.000	0.060	0.16	0.26	12.00	69.89	17.97	300	PVC	0.50%	12.1	68.38	0.97	0.21	0.37								
WS-01 will be taking on 0.012 (C = 0.20) & 0.014 (C = 090) ha of off-site runoff which will be taken in and controlled, WS-01 & WS-02 peaks flows added to size pipe / perform Q/Qfull ratio calculation																										

## User Inputs

<b>Chamber Model:</b>	SC-310
<b>Outlet Control Structure:</b>	Yes
<b>Project Name:</b>	220536 - 5254 Bank Street
<b>Engineer:</b>	undefined undefined
<b>Project Location:</b>	Ontario
<b>Measurement Type:</b>	Metric
<b>Required Storage Volume:</b>	43.68 cubic meters.
<b>Stone Porosity:</b>	40%
<b>Stone Foundation Depth:</b>	153 mm.
<b>Stone Above Chambers:</b>	153 mm.
<b>Design Constraint Dimensions:</b>	(5.00 m. x 26.00 m.)

## Results

### System Volume and Bed Size

<b>Installed Storage Volume:</b>	43.95 cubic meters.
<b>Storage Volume Per Chamber:</b>	0.42 cubic meters.
<b>Number Of Chambers Required:</b>	44
<b>Number Of End Caps Required:</b>	8
<b>Chamber Rows:</b>	4
<b>Maximum Length:</b>	25.85 m.
<b>Maximum Width:</b>	4.48 m.
<b>Approx. Bed Size Required:</b>	115.68 square meters.
<b>Average Cover Over Chambers:</b>	N/A .

### System Components

<b>Amount Of Stone Required:</b>	64 cubic meters
<b>Volume Of Excavation (Not Including Fill):</b>	83 cubic meters
<b>Total Non-woven Geotextile Required:</b>	330 square meters
<b>Woven Geotextile Required (excluding Isolator Row):</b>	18 square meters
<b>Woven Geotextile Required (Isolator Row):</b>	36 square meters
<b>Total Woven Geotextile Required:</b>	53 square meters
<b>Impervious Liner Required:</b>	0 square meters

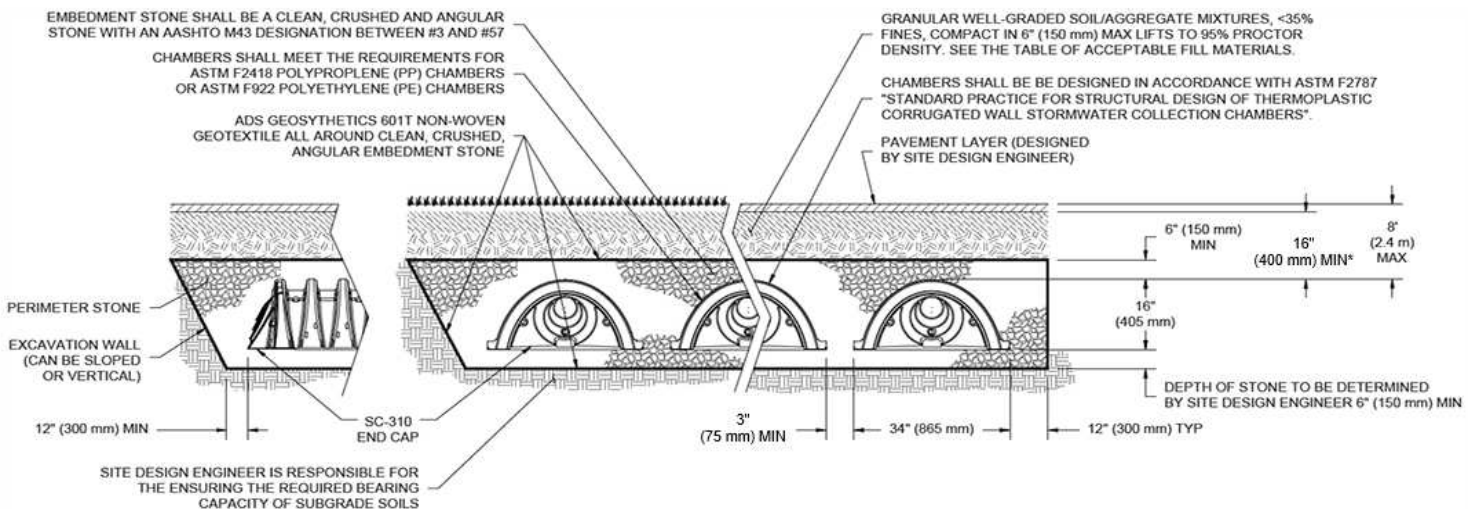

\*MINIMUM COVER TO BOTTOM OF FLEXIBLE PAVEMENT. FOR UNPAVED INSTALLATIONS WHERE RUTTING FROM VEHICLES MAY OCCUR, INCREASE COVER TO 22" (550 mm).

PROJECT INFORMATION	
ENGINEERED PRODUCT MANAGER	
ADS SALES REP	
PROJECT NO.	



# 220536 - 5254 BANK STREET

## OTTAWA, ON, CANADA

### SC-310 STORMTECH CHAMBER SPECIFICATIONS

1. CHAMBERS SHALL BE STORMTECH SC-310.
2. CHAMBERS SHALL BE ARCH-SHAPED AND SHALL BE MANUFACTURED FROM VIRGIN, IMPACT-MODIFIED POLYPROPYLENE OR POLYETHYLENE COPOLYMERS.
3. CHAMBERS SHALL BE CERTIFIED TO CSA B184, "POLYMERIC SUB-SURFACE STORMWATER MANAGEMENT STRUCTURES", AND MEET THE REQUIREMENTS OF ASTM F2922 (POLETHYLENE) OR ASTM F2418 (POLYPROPYLENE), "STANDARD SPECIFICATION FOR CORRUGATED WALL STORMWATER COLLECTION CHAMBERS".
4. CHAMBER ROWS SHALL PROVIDE CONTINUOUS, UNOBSTRUCTED INTERNAL SPACE WITH NO INTERNAL SUPPORTS THAT WOULD IMPEDE FLOW OR LIMIT ACCESS FOR INSPECTION.
5. THE STRUCTURAL DESIGN OF THE CHAMBERS, THE STRUCTURAL BACKFILL, AND THE INSTALLATION REQUIREMENTS SHALL ENSURE THAT THE LOAD FACTORS SPECIFIED IN THE AASHTO LRFD BRIDGE DESIGN SPECIFICATIONS, SECTION 12.12, ARE MET FOR: 1) LONG-DURATION DEAD LOADS AND 2) SHORT-DURATION LIVE LOADS, BASED ON THE CSA S6 CL-625 TRUCK AND THE AASHTO DESIGN TRUCK WITH CONSIDERATION FOR IMPACT AND MULTIPLE VEHICLE PRESENCES.
6. CHAMBERS SHALL BE DESIGNED, TESTED AND ALLOWABLE LOAD CONFIGURATIONS DETERMINED IN ACCORDANCE WITH ASTM F2787, "STANDARD PRACTICE FOR STRUCTURAL DESIGN OF THERMOPLASTIC CORRUGATED WALL STORMWATER COLLECTION CHAMBERS". LOAD CONFIGURATIONS SHALL INCLUDE: 1) INSTANTANEOUS (<1 MIN) AASHTO DESIGN TRUCK LIVE LOAD ON MINIMUM COVER 2) MAXIMUM PERMANENT (75-YR) COVER LOAD AND 3) ALLOWABLE COVER WITH PARKED (1-WEEK) AASHTO DESIGN TRUCK.
7. REQUIREMENTS FOR HANDLING AND INSTALLATION:
  - TO MAINTAIN THE WIDTH OF CHAMBERS DURING SHIPPING AND HANDLING, CHAMBERS SHALL HAVE INTEGRAL, INTERLOCKING STACKING LUGS.
  - TO ENSURE A SECURE JOINT DURING INSTALLATION AND BACKFILL, THE HEIGHT OF THE CHAMBER JOINT SHALL NOT BE LESS THAN 50 mm (2").
  - TO ENSURE THE INTEGRITY OF THE ARCH SHAPE DURING INSTALLATION, a) THE ARCH STIFFNESS CONSTANT AS DEFINED IN SECTION 6.2.8 OF ASTM F2922 SHALL BE GREATER THAN OR EQUAL TO 325 LBS/FT<sup>2</sup>%. AND b) TO RESIST CHAMBER DEFORMATION DURING INSTALLATION AT ELEVATED TEMPERATURES (ABOVE 23° C / 73° F), CHAMBERS SHALL BE PRODUCED FROM REFLECTIVE GOLD OR YELLOW COLORS.
8. ONLY CHAMBERS THAT ARE APPROVED BY THE SITE DESIGN ENGINEER WILL BE ALLOWED. UPON REQUEST BY THE SITE DESIGN ENGINEER OR OWNER, THE CHAMBER MANUFACTURER SHALL SUBMIT A STRUCTURAL EVALUATION FOR APPROVAL BEFORE DELIVERING CHAMBERS TO THE PROJECT SITE AS FOLLOWS:
  - THE STRUCTURAL EVALUATION SHALL BE SEALED BY A REGISTERED PROFESSIONAL ENGINEER.
  - THE STRUCTURAL EVALUATION SHALL DEMONSTRATE THAT THE SAFETY FACTORS ARE GREATER THAN OR EQUAL TO 1.95 FOR DEAD LOAD AND 1.75 FOR LIVE LOAD, THE MINIMUM REQUIRED BY ASTM F2787 AND BY SECTIONS 3 AND 12.12 OF THE AASHTO LRFD BRIDGE DESIGN SPECIFICATIONS FOR THERMOPLASTIC PIPE.
  - THE TEST DERIVED CREEP MODULUS AS SPECIFIED IN ASTM F2922 SHALL BE USED FOR PERMANENT DEAD LOAD DESIGN EXCEPT THAT IT SHALL BE THE 75-YEAR MODULUS USED FOR DESIGN.
9. CHAMBERS AND END CAPS SHALL BE PRODUCED AT AN ISO 9001 CERTIFIED MANUFACTURING FACILITY.
10. MANIFOLD SIZE TO BE DETERMINED BY SITE DESIGN ENGINEER. SEE TECH NOTE #6.32 FOR MANIFOLD SIZING GUIDANCE. DUE TO THE ADAPTATION OF THIS CHAMBER SYSTEM TO SPECIFIC SITE AND DESIGN CONSTRAINTS, IT MAY BE NECESSARY TO CUT AND COUPLE ADDITIONAL PIPE TO STANDARD MANIFOLD COMPONENTS IN THE FIELD.
11. ADS DOES NOT DESIGN OR PROVIDE MEMBRANE LINER SYSTEMS. TO MINIMIZE THE LEAKAGE POTENTIAL OF LINER SYSTEMS, THE MEMBRANE LINER SYSTEM SHOULD BE DESIGNED BY A KNOWLEDGEABLE GEOTEXTILE PROFESSIONAL AND INSTALLED BY A QUALIFIED CONTRACTOR.

### IMPORTANT - NOTES FOR THE BIDDING AND INSTALLATION OF THE SC-310 SYSTEM

1. STORMTECH SC-310 CHAMBERS SHALL NOT BE INSTALLED UNTIL THE MANUFACTURER'S REPRESENTATIVE HAS COMPLETED A PRE-CONSTRUCTION MEETING WITH THE INSTALLERS.
2. STORMTECH SC-310 CHAMBERS SHALL BE INSTALLED IN ACCORDANCE WITH THE "STORMTECH SC-310/SC-740/DC-780 CONSTRUCTION GUIDE".
3. CHAMBERS ARE NOT TO BE BACKFILLED WITH A DOZER OR AN EXCAVATOR SITUATED OVER THE CHAMBERS. STORMTECH RECOMMENDS 3 BACKFILL METHODS:
  - STONESHOOTER LOCATED OFF THE CHAMBER BED.
  - BACKFILL AS ROWS ARE BUILT USING AN EXCAVATOR ON THE FOUNDATION STONE OR SUBGRADE.
  - BACKFILL FROM OUTSIDE THE EXCAVATION USING A LONG BOOM HOE OR EXCAVATOR.
4. THE FOUNDATION STONE SHALL BE LEVELED AND COMPACTED PRIOR TO PLACING CHAMBERS.
5. JOINTS BETWEEN CHAMBERS SHALL BE PROPERLY SEATED PRIOR TO PLACING STONE.
6. MAINTAIN MINIMUM - 80 mm (3") SPACING BETWEEN THE CHAMBER ROWS.
7. EMBEDMENT STONE SURROUNDING CHAMBERS MUST BE A CLEAN, CRUSHED, ANGULAR STONE OR RECYCLED CONCRETE; AASHTO M43 #3, 357, 4, 467, 5, 56, OR 57.
8. THE CONTRACTOR MUST REPORT ANY DISCREPANCIES WITH CHAMBER FOUNDATION MATERIALS BEARING CAPACITIES TO THE SITE DESIGN ENGINEER.
9. ADS RECOMMENDS THE USE OF "FLEXSTORM CATCH IT" INSERTS DURING CONSTRUCTION FOR ALL INLETS TO PROTECT THE SUBSURFACE STORMWATER MANAGEMENT SYSTEM FROM CONSTRUCTION SITE RUNOFF.

### NOTES FOR CONSTRUCTION EQUIPMENT

1. STORMTECH SC-310 CHAMBERS SHALL BE INSTALLED IN ACCORDANCE WITH THE "STORMTECH SC-310/SC-740/DC-780 CONSTRUCTION GUIDE".
2. THE USE OF CONSTRUCTION EQUIPMENT OVER SC-310 & SC-740 CHAMBERS IS LIMITED:
  - NO EQUIPMENT IS ALLOWED ON BARE CHAMBERS.
  - NO RUBBER Tired LOADERS, DUMP TRUCKS, OR EXCAVATORS ARE ALLOWED UNTIL PROPER FILL DEPTHS ARE REACHED IN ACCORDANCE WITH THE "STORMTECH SC-310/SC-740/DC-780 CONSTRUCTION GUIDE".
  - WEIGHT LIMITS FOR CONSTRUCTION EQUIPMENT CAN BE FOUND IN THE "STORMTECH SC-310/SC-740/DC-780 CONSTRUCTION GUIDE".
3. FULL 900 mm (36") OF STABILIZED COVER MATERIALS OVER THE CHAMBERS IS REQUIRED FOR DUMP TRUCK TRAVEL OR DUMPING.

**USE OF A DOZER TO PUSH EMBEDMENT STONE BETWEEN THE ROWS OF CHAMBERS MAY CAUSE DAMAGE TO THE CHAMBERS AND IS NOT AN ACCEPTABLE BACKFILL METHOD. ANY CHAMBERS DAMAGED BY THE "DUMP AND PUSH" METHOD ARE NOT COVERED UNDER THE STORMTECH STANDARD WARRANTY.**

CONTACT STORMTECH AT 1-800-821-6710 WITH ANY QUESTIONS ON INSTALLATION REQUIREMENTS OR WEIGHT LIMITS FOR CONSTRUCTION EQUIPMENT.

PROPOSED LAYOUT		CONCEPTUAL ELEVATIONS		*INVERT ABOVE BASE OF CHAMBER				
				PART TYPE	ITEM ON LAYOUT	DESCRIPTION	INVERT*	MAX FLOW
44	STORMTECH SC-310 CHAMBERS	MAXIMUM ALLOWABLE GRADE (TOP OF PAVEMENT/UNPAVED):	2.997					
8	STORMTECH SC-310 END CAPS	MINIMUM ALLOWABLE GRADE (UNPAVED WITH TRAFFIC):	1.118	PREFABRICATED EZ END CAP	A	300 mm BOTTOM PREFABRICATED EZ END CAP, PART#: SC310ECEZ / TYP OF ALL 300 mm BOTTOM CONNECTIONS AND ISOLATOR PLUS ROWS	23 mm	
152	STONE ABOVE (mm)	MINIMUM ALLOWABLE GRADE (UNPAVED NO TRAFFIC):	0.965					
152	STONE BELOW (mm)	MINIMUM ALLOWABLE GRADE (TOP OF RIGID CONCRETE PAVEMENT):	0.965					
40	STONE VOID	MINIMUM ALLOWABLE GRADE (BASE OF FLEXIBLE PAVEMENT):	0.965	PRE-CORED END CAP	B	200 mm TOP PRE-CORED END CAP, PART#: SC310EPE08TPC / TYP OF ALL 200 mm TOP CONNECTIONS	89 mm	
43.9	INSTALLED SYSTEM VOLUME (m³) (PERIMETER STONE INCLUDED) (COVER STONE INCLUDED) (BASE STONE INCLUDED)	TOP OF STONE:	0.711	PRE-CORED END CAP	C	200 mm BOTTOM PRE-CORED END CAP, PART#: SC310EPE08BPC / TYP OF ALL 200 mm BOTTOM CONNECTIONS	15 mm	
		TOP OF SC-310 CHAMBER:	0.559					
		200 mm x 200 mm TOP MANIFOLD INVERT:	0.241					
		300 mm ISOLATOR ROW PLUS INVERT:	0.175	FLAMP	D	INSTALL FLAMP ON 300 mm ACCESS PIPE / PART#: SC31012RAMP (TYP 2 PLACES)		
115.7	SYSTEM AREA (m²)	300 mm ISOLATOR ROW PLUS INVERT:	0.175	MANIFOLD	E	200 mm x 200 mm TOP MANIFOLD, MOLDED FITTINGS	89 mm	
60.6	SYSTEM PERIMETER (m)	200 mm BOTTOM CONNECTION INVERT:	0.168	PIPE CONNECTION	F	200 mm BOTTOM CONNECTION	15 mm	
		BOTTOM OF SC-310 CHAMBER:	0.152	NYLOPLAST (INLET W/ ISO PLUS ROW)	G	750 mm DIAMETER (610 mm SUMP MIN)		50 L/s IN
		UNDERDRAIN INVERT:	0.000	NYLOPLAST (INLET W/ ISO PLUS ROW)	H	750 mm DIAMETER (610 mm SUMP MIN)		
		BOTTOM OF STONE:	0.000	NYLOPLAST (OUTLET)	I	750 mm DIAMETER (DESIGN BY ENGINEER)		20 L/s OUT
				UNDERDRAIN	J	100 mm ADS N-12 DUAL WALL PERFORATED HDPE UNDERDRAIN		

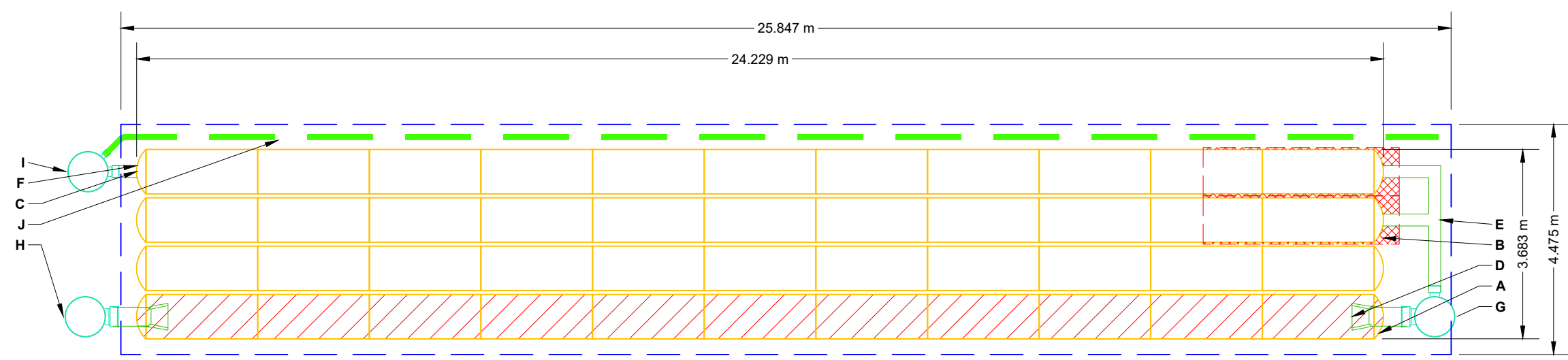

- ISOLATOR ROW PLUS (SEE DETAIL)
- PLACE MINIMUM 3.810 m OF ADSPLUS625 WOVEN GEOTEXTILE OVER BEDDING STONE AND UNDERNEATH CHAMBER FEET FOR SCOUR PROTECTION AT ALL CHAMBER INLET ROWS
- BED LIMITS

**NOTES**

- THE SITE DESIGN ENGINEER MUST REVIEW ELEVATIONS AND IF NECESSARY ADJUST GRADING TO ENSURE THE CHAMBER COVER REQUIREMENTS ARE MET.
- **NOT FOR CONSTRUCTION:** THIS LAYOUT IS FOR DIMENSIONAL PURPOSES ONLY TO PROVE CONCEPT & THE REQUIRED STORAGE VOLUME CAN BE ACHIEVED ON SITE.

220536 - 5254 BANK STREET

OTTAWA, ON, CANADA

DATE: 06/27/2025

PROJECT #:

DATE: 06/27/2025

CHK

DATE

DRW

CHK

DATE

DESCRIPTION

DRAWN: UU

CHECKED: N/A

StormTech®  
Chamber System

1-800-821-6710 | WWW.STORMTECH.COM

4640 TRUEMAN BLVD  
HILLIARD, OH 43026  
1-800-733-7473

SCALE = 1 : 100

THIS DRAWING HAS BEEN PREPARED BASED ON INFORMATION PROVIDED TO ADS/STORMTECH UNDER THE DIRECTION OF THE PROJECT'S ENGINEER OF RECORD (EOR) OR OTHER PROJECT REPRESENTATIVE. THIS DRAWING IS NOT INTENDED FOR USE IN BIDDING OR CONSTRUCTION WITHOUT THE EOR'S PRIOR APPROVAL. EOR SHALL REVIEW THIS DRAWING PRIOR TO BIDDING AND/OR CONSTRUCTION. IT IS THE ULTIMATE RESPONSIBILITY OF THE EOR TO ENSURE THAT THE PRODUCT(S) DEPICTED AND ALL ASSOCIATED DETAILS MEET ALL APPLICABLE LAWS, REGULATIONS, AND PROJECT REQUIREMENTS.

SHEET  
2 OF 6

## ACCEPTABLE FILL MATERIALS: STORMTECH SC-310 CHAMBER SYSTEMS

MATERIAL LOCATION		DESCRIPTION	AASHTO MATERIAL CLASSIFICATIONS	COMPACTION / DENSITY REQUIREMENT
D	<b>FINAL FILL:</b> FILL MATERIAL FOR LAYER 'D' STARTS FROM THE TOP OF THE 'C' LAYER TO THE BOTTOM OF FLEXIBLE PAVEMENT OR UNPAVED FINISHED GRADE ABOVE. NOTE THAT PAVEMENT SUBBASE MAY BE PART OF THE 'D' LAYER.	ANY SOIL/ROCK MATERIALS, NATIVE SOILS, OR PER ENGINEER'S PLANS. CHECK PLANS FOR PAVEMENT SUBGRADE REQUIREMENTS.	N/A	PREPARE PER SITE DESIGN ENGINEER'S PLANS. PAVED INSTALLATIONS MAY HAVE STRINGENT MATERIAL AND PREPARATION REQUIREMENTS.
C	<b>INITIAL FILL:</b> FILL MATERIAL FOR LAYER 'C' STARTS FROM THE TOP OF THE EMBEDMENT STONE ('B' LAYER) TO 18" (460 mm) ABOVE THE TOP OF THE CHAMBER. NOTE THAT PAVEMENT SUBBASE MAY BE A PART OF THE 'C' LAYER.	GRANULAR WELL-GRADED SOIL/AGGREGATE MIXTURES, <35% FINES OR PROCESSED AGGREGATE.  MOST PAVEMENT SUBBASE MATERIALS CAN BE USED IN LIEU OF THIS LAYER.	AASHTO M145 <sup>1</sup> A-1, A-2-4, A-3  OR  AASHTO M43 <sup>1</sup> 3, 357, 4, 467, 5, 56, 57, 6, 67, 68, 7, 78, 8, 89, 9, 10	BEGIN COMPACTIONS AFTER 12" (300 mm) OF MATERIAL OVER THE CHAMBERS IS REACHED. COMPACT ADDITIONAL LAYERS IN 6" (150 mm) MAX LIFTS TO A MIN. 95% PROCTOR DENSITY FOR WELL GRADED MATERIAL AND 95% RELATIVE DENSITY FOR PROCESSED AGGREGATE MATERIALS. ROLLER GROSS VEHICLE WEIGHT NOT TO EXCEED 12,000 lbs (53 kN). DYNAMIC FORCE NOT TO EXCEED 20,000 lbs (89 kN).
B	<b>EMBEDMENT STONE:</b> FILL SURROUNDING THE CHAMBERS FROM THE FOUNDATION STONE ('A' LAYER) TO THE 'C' LAYER ABOVE.	CLEAN, CRUSHED, ANGULAR STONE OR RECYCLED CONCRETE <sup>5</sup>	AASHTO M43 <sup>1</sup> 3, 357, 4, 467, 5, 56, 57	NO COMPACTION REQUIRED.
A	<b>FOUNDATION STONE:</b> FILL BELOW CHAMBERS FROM THE SUBGRADE UP TO THE FOOT (BOTTOM) OF THE CHAMBER.	CLEAN, CRUSHED, ANGULAR STONE OR RECYCLED CONCRETE <sup>5</sup>	AASHTO M43 <sup>1</sup> 3, 357, 4, 467, 5, 56, 57	PLATE COMPACT OR ROLL TO ACHIEVE A FLAT SURFACE. <sup>2,3</sup>

**PLEASE NOTE:**

- THE LISTED AASHTO DESIGNATIONS ARE FOR GRADATIONS ONLY. THE STONE MUST ALSO BE CLEAN, CRUSHED, ANGULAR. FOR EXAMPLE, A SPECIFICATION FOR #4 STONE WOULD STATE: "CLEAN, CRUSHED, ANGULAR NO. 4 (AASHTO M43) STONE".
- STORMTECH COMPACTION REQUIREMENTS ARE MET FOR 'A' LOCATION MATERIALS WHEN PLACED AND COMPACTED IN 6" (150 mm) (MAX) LIFTS USING TWO FULL COVERAGES WITH A VIBRATORY COMPACTOR.
- WHERE INFILTRATION SURFACES MAY BE COMPROMISED BY COMPACTION, FOR STANDARD DESIGN LOAD CONDITIONS, A FLAT SURFACE MAY BE ACHIEVED BY RAKING OR DRAGGING WITHOUT COMPACTION EQUIPMENT. FOR SPECIAL LOAD DESIGNS, CONTACT STORMTECH FOR COMPACTION REQUIREMENTS.
- ONCE LAYER 'C' IS PLACED, ANY SOIL/MATERIAL CAN BE PLACED IN LAYER 'D' UP TO THE FINISHED GRADE. MOST PAVEMENT SUBBASE SOILS CAN BE USED TO REPLACE THE MATERIAL REQUIREMENTS OF LAYER 'C' OR 'D' AT THE SITE DESIGN ENGINEER'S DISCRETION.
- WHERE RECYCLED CONCRETE AGGREGATE IS USED IN LAYERS 'A' OR 'B' THE MATERIAL SHOULD ALSO MEET THE ACCEPTABILITY CRITERIA OUTLINED IN TECHNICAL NOTE 6.20 "RECYCLED CONCRETE STRUCTURAL BACKFILL".

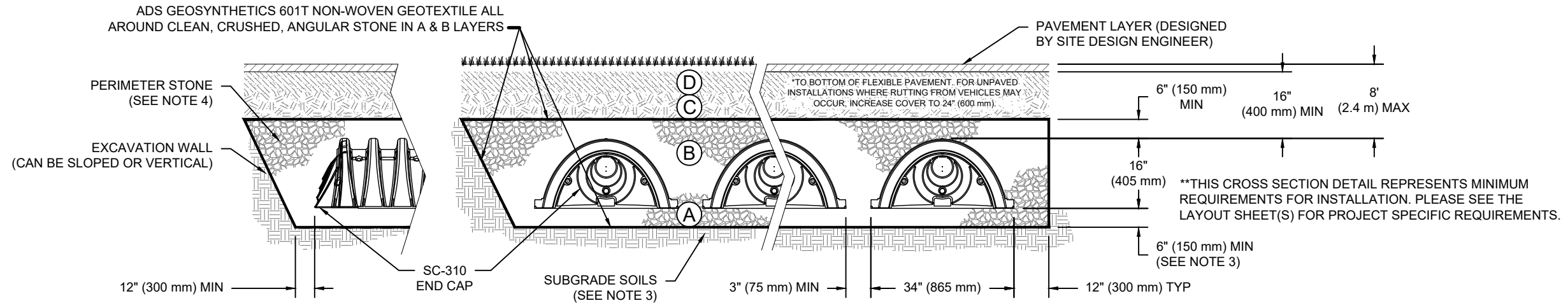

**NOTES:**

- CHAMBERS SHALL MEET THE REQUIREMENTS OF ASTM F2922 (POLETHYLENE) OR ASTM F2418 (POLYPROPYLENE), "STANDARD SPECIFICATION FOR CORRUGATED WALL STORMWATER COLLECTION CHAMBERS".
- SC-310 CHAMBERS SHALL BE DESIGNED IN ACCORDANCE WITH ASTM F2787 "STANDARD PRACTICE FOR STRUCTURAL DESIGN OF THERMOPLASTIC CORRUGATED WALL STORMWATER COLLECTION CHAMBERS".
- THE SITE DESIGN ENGINEER IS RESPONSIBLE FOR ASSESSING THE BEARING RESISTANCE (ALLOWABLE BEARING CAPACITY) OF THE SUBGRADE SOILS AND THE DEPTH OF FOUNDATION STONE WITH CONSIDERATION FOR THE RANGE OF EXPECTED SOIL MOISTURE CONDITIONS. REFERENCE STORMTECH DESIGN MANUAL FOR BEARING CAPACITY GUIDANCE.
- PERIMETER STONE MUST BE EXTENDED HORIZONTALLY TO THE EXCAVATION WALL FOR BOTH VERTICAL AND SLOPED EXCAVATION WALLS.
- REQUIREMENTS FOR HANDLING AND INSTALLATION:
  - TO MAINTAIN THE WIDTH OF CHAMBERS DURING SHIPPING AND HANDLING, CHAMBERS SHALL HAVE INTEGRAL, INTERLOCKING STACKING LUGS.
  - TO ENSURE A SECURE JOINT DURING INSTALLATION AND BACKFILL, THE HEIGHT OF THE CHAMBER JOINT SHALL NOT BE LESS THAN 2".
  - TO ENSURE THE INTEGRITY OF THE ARCH SHAPE DURING INSTALLATION, a) THE ARCH STIFFNESS CONSTANT SHALL BE GREATER THAN OR EQUAL TO 325 LBS/FT/%. THE ASC IS DEFINED IN SECTION 6.2.8 OF ASTM F2418. AND b) TO RESIST CHAMBER DEFORMATION DURING INSTALLATION AT ELEVATED TEMPERATURES (ABOVE 73° F / 23° C), CHAMBERS SHALL BE PRODUCED FROM REFLECTIVE GOLD OR YELLOW COLORS.

220536 - 5254 BANK STREET

OTTAWA, ON, CANADA

DRAWN: UU

DATE: 06/27/2025

CHECKED: N/A

PROJECT #:

DESCRIPTION

CHK

DRW

DATE

1-800-821-6710 | WWW.STORMTECH.COM

**StormTech®**  
Chamber System

4640 TRUEMAN BLVD  
HILLIARD, OH 43026  
1-800-733-7473



THIS DRAWING HAS BEEN PREPARED BASED ON INFORMATION PROVIDED TO ADS BY STORMTECH UNDER THE DIRECTION OF THE PROJECT'S ENGINEER OF RECORD. EOR SHALL REVIEW THIS DRAWING PRIOR TO BIDDING AND/OR CONSTRUCTION. IT IS THE ULTIMATE RESPONSIBILITY OF THE EOR TO ENSURE THAT THE PRODUCT(S) DEPICTED AND ALL ASSOCIATED DETAILS MEET ALL APPLICABLE LAWS, REGULATIONS, AND PROJECT REQUIREMENTS.

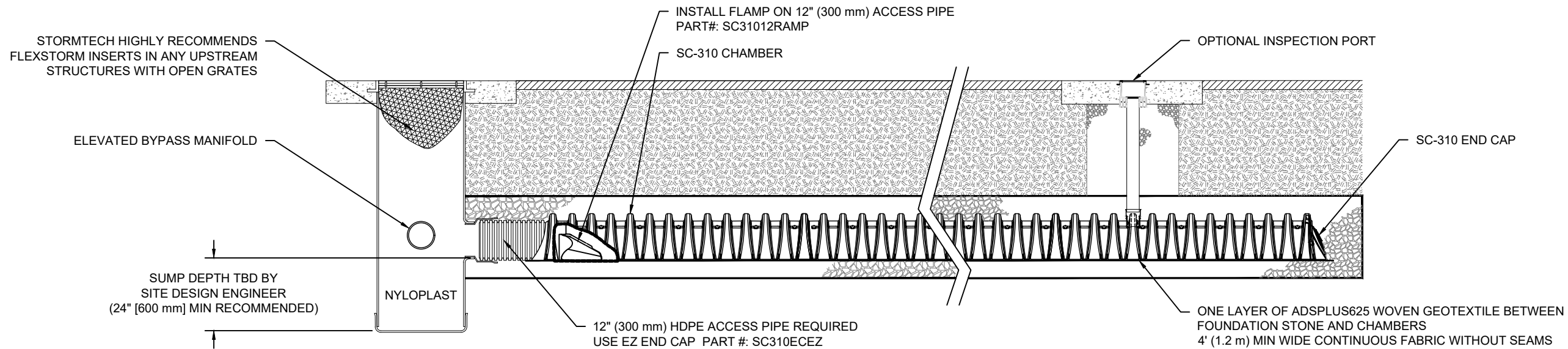

**SC-310 ISOLATOR ROW PLUS DETAIL**  
NTS

**INSPECTION & MAINTENANCE**

- STEP 1) INSPECT ISOLATOR ROW PLUS FOR SEDIMENT
- A. INSPECTION PORTS (IF PRESENT)
    - A.1. REMOVE/OPEN LID ON NYLOPLAST INLINE DRAIN
    - A.2. REMOVE AND CLEAN FLEXSTORM FILTER IF INSTALLED
    - A.3. USING A FLASHLIGHT AND STADIA ROD, MEASURE DEPTH OF SEDIMENT AND RECORD ON MAINTENANCE LOG
    - A.4. LOWER A CAMERA INTO ISOLATOR ROW PLUS FOR VISUAL INSPECTION OF SEDIMENT LEVELS (OPTIONAL)
    - A.5. IF SEDIMENT IS AT, OR ABOVE, 3" (80 mm) PROCEED TO STEP 2. IF NOT, PROCEED TO STEP 3.
  - B. ALL ISOLATOR PLUS ROWS
    - B.1. REMOVE COVER FROM STRUCTURE AT UPSTREAM END OF ISOLATOR ROW PLUS
    - B.2. USING A FLASHLIGHT, INSPECT DOWN THE ISOLATOR ROW PLUS THROUGH OUTLET PIPE
      - i) MIRRORS ON POLES OR CAMERAS MAY BE USED TO AVOID A CONFINED SPACE ENTRY
      - ii) FOLLOW OSHA REGULATIONS FOR CONFINED SPACE ENTRY IF ENTERING MANHOLE
    - B.3. IF SEDIMENT IS AT, OR ABOVE, 3" (80 mm) PROCEED TO STEP 2. IF NOT, PROCEED TO STEP 3.
- STEP 2) CLEAN OUT ISOLATOR ROW PLUS USING THE JETVAC PROCESS
- A. A FIXED CULVERT CLEANING NOZZLE WITH REAR FACING SPREAD OF 45" (1.1 m) OR MORE IS PREFERRED
  - B. APPLY MULTIPLE PASSES OF JETVAC UNTIL BACKFLUSH WATER IS CLEAN
  - C. VACUUM STRUCTURE SUMP AS REQUIRED
- STEP 3) REPLACE ALL COVERS, GRATES, FILTERS, AND LIDS; RECORD OBSERVATIONS AND ACTIONS.
- STEP 4) INSPECT AND CLEAN BASINS AND MANHOLES UPSTREAM OF THE STORMTECH SYSTEM.

**NOTES**

1. INSPECT EVERY 6 MONTHS DURING THE FIRST YEAR OF OPERATION. ADJUST THE INSPECTION INTERVAL BASED ON PREVIOUS OBSERVATIONS OF SEDIMENT ACCUMULATION AND HIGH WATER ELEVATIONS.
2. CONDUCT JETTING AND VACTORING ANNUALLY OR WHEN INSPECTION SHOWS THAT MAINTENANCE IS NECESSARY.

220536 - 5254 BANK STREET

OTTAWA, ON, CANADA

DRAWN: UU

CHECKED: N/A

DATE: 06/27/2025

PROJECT #:

DATE	DRW	CHK	DESCRIPTION

**StormTech®**  
Chamber System

1-800-821-6710 | WWW.STORMTECH.COM

4640 TRUEMAN BLVD  
HILLIARD, OH 43026  
1-800-733-7473



THIS DRAWING HAS BEEN PREPARED BASED ON INFORMATION PROVIDED TO ADS/STORMTECH UNDER THE DIRECTION OF THE PROJECT'S ENGINEER OF RECORD (EOR) OR OTHER PROJECT REPRESENTATIVE. THIS DRAWING IS NOT INTENDED FOR USE IN BIDDING OR CONSTRUCTION WITHOUT THE EOR'S PRIOR APPROVAL. EOR SHALL REVIEW THIS DRAWING PRIOR TO BIDDING AND/OR CONSTRUCTION. IT IS THE ULTIMATE RESPONSIBILITY OF THE EOR TO ENSURE THAT THE PRODUCT(S) DEPICTED AND ALL ASSOCIATED DETAILS MEET ALL APPLICABLE LAWS, REGULATIONS, AND PROJECT REQUIREMENTS.

## UNDERDRAIN DETAIL

NTS

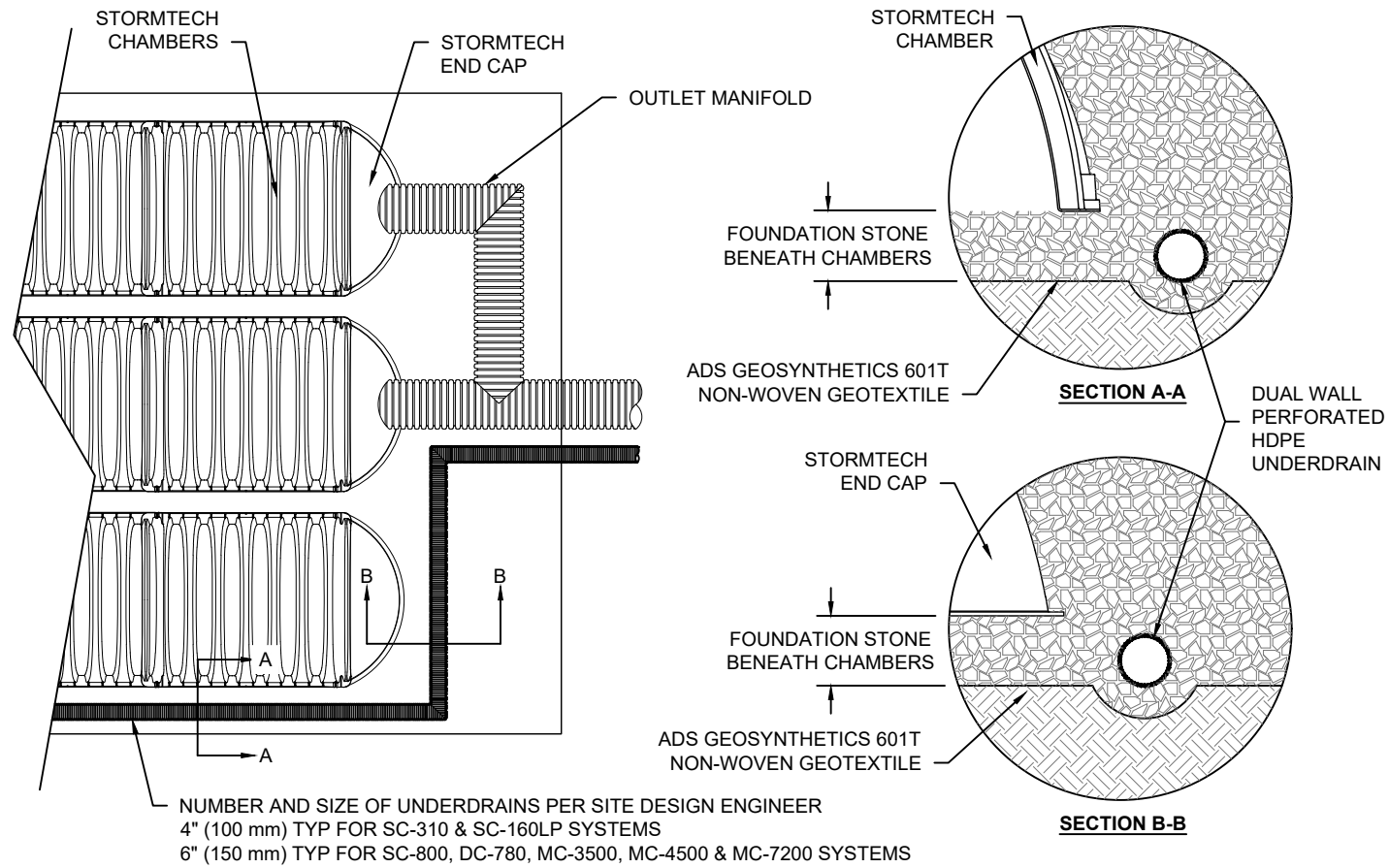

## SC-310 TECHNICAL SPECIFICATION

NTS

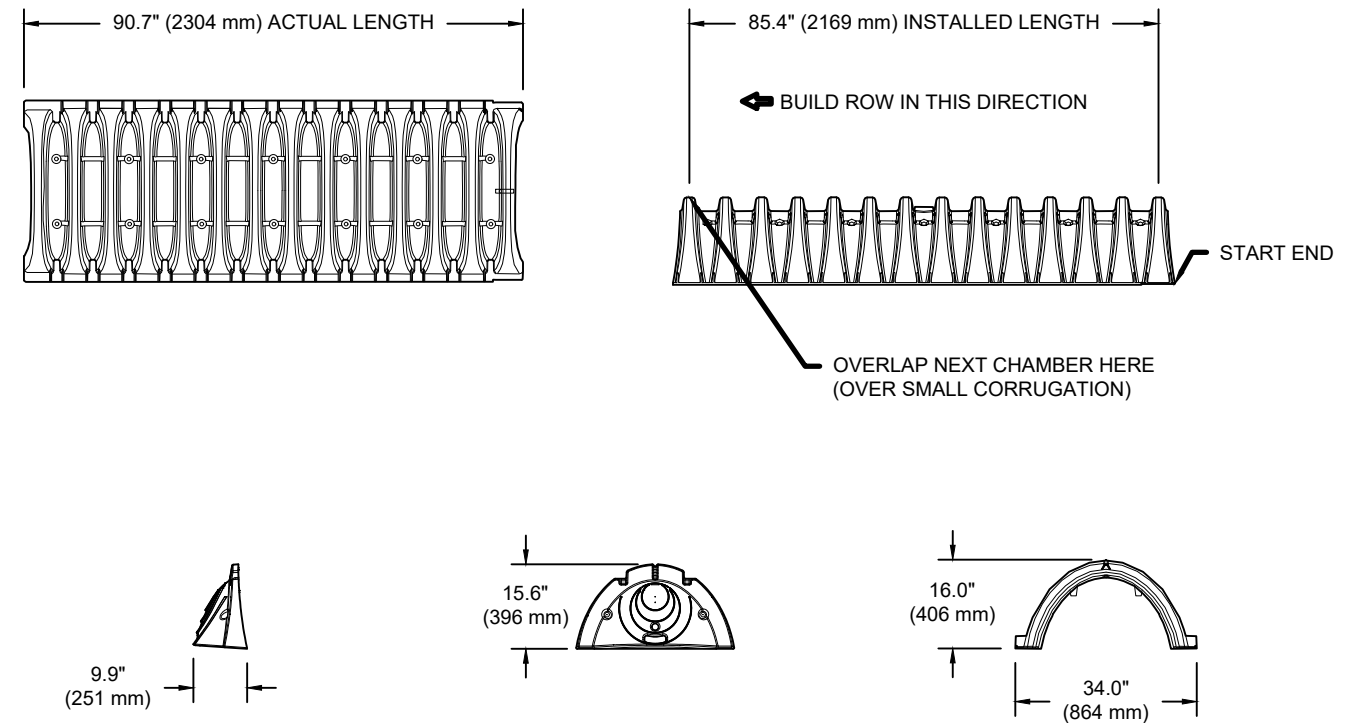

### NOMINAL CHAMBER SPECIFICATIONS

SIZE (W X H X INSTALLED LENGTH)	34.0" X 16.0" X 85.4"	(864 mm X 406 mm X 2169 mm)
CHAMBER STORAGE	14.7 CUBIC FEET	(0.42 m <sup>3</sup> )
MINIMUM INSTALLED STORAGE*	29.3 CUBIC FEET	(0.83 m <sup>3</sup> )
WEIGHT	35.0 lbs.	(16.8 kg)

\*ASSUMES 6" (152 mm) ABOVE, BELOW, AND 3" (75 mm) BETWEEN CHAMBERS

PART #	STUB	B	C
SC310EPE06TPC	6" (150 mm)	5.8" (147 mm)	---
SC310EPE06BPC		---	0.5" (13 mm)
SC310EPE08TPC	8" (200 mm)	3.5" (89 mm)	---
SC310EPE08BPC		---	0.6" (15 mm)
SC310EPE10TPC	10" (250 mm)	1.4" (36 mm)	---
SC310EPE10BPC		---	0.7" (18 mm)
SC310ECEZ*	12" (300 mm)	---	0.9" (23 mm)

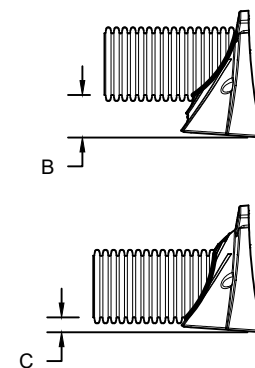

ALL STUBS, EXCEPT FOR THE SC310ECEZ ARE PLACED AT BOTTOM OF END CAP SUCH THAT THE OUTSIDE DIAMETER OF THE STUB IS FLUSH WITH THE BOTTOM OF THE END CAP. FOR ADDITIONAL INFORMATION CONTACT STORMTECH AT 1-888-892-2694.

\* FOR THE SC310ECEZ THE 12" (300 mm) STUB LIES BELOW THE BOTTOM OF THE END CAP APPROXIMATELY 0.25" (6 mm). BACKFILL MATERIAL SHOULD BE REMOVED FROM BELOW THE N-12 STUB SO THAT THE FITTING SITS LEVEL.

NOTE: ALL DIMENSIONS ARE NOMINAL; PRE-CORED END CAPS END WITH "PC"

220536 - 5254 BANK STREET

OTTAWA, ON, CANADA

DATE: 06/27/2025

DRAWN: UU

CHECKED: N/A

PROJECT #:

DESCRIPTION

DATE

CHK

1-800-821-6710 | WWW.STORMTECH.COM

THIS DRAWING HAS BEEN PREPARED BASED ON INFORMATION PROVIDED TO ADS/STORMTECH UNDER THE DIRECTION OF THE PROJECT'S ENGINEER OF RECORD (EOR) OR OTHER PROJECT REPRESENTATIVE. THIS DRAWING IS NOT INTENDED FOR USE IN BIDDING OR CONSTRUCTION WITHOUT THE EOR'S PRIOR APPROVAL. EOR SHALL REVIEW THIS DRAWING PRIOR TO BIDDING AND/OR CONSTRUCTION. IT IS THE ULTIMATE RESPONSIBILITY OF THE EOR TO ENSURE THAT THE PRODUCT(S) DEPICTED AND ALL ASSOCIATED DETAILS MEET ALL APPLICABLE LAWS, REGULATIONS, AND PROJECT REQUIREMENTS.

**StormTech®**  
Chamber System

4640 TRUEMAN BLVD  
HILLIARD, OH 43026  
1-800-733-7473

**ADS**

SHEET

5 OF 6

# NYLOPLAST DRAIN BASIN

NTS

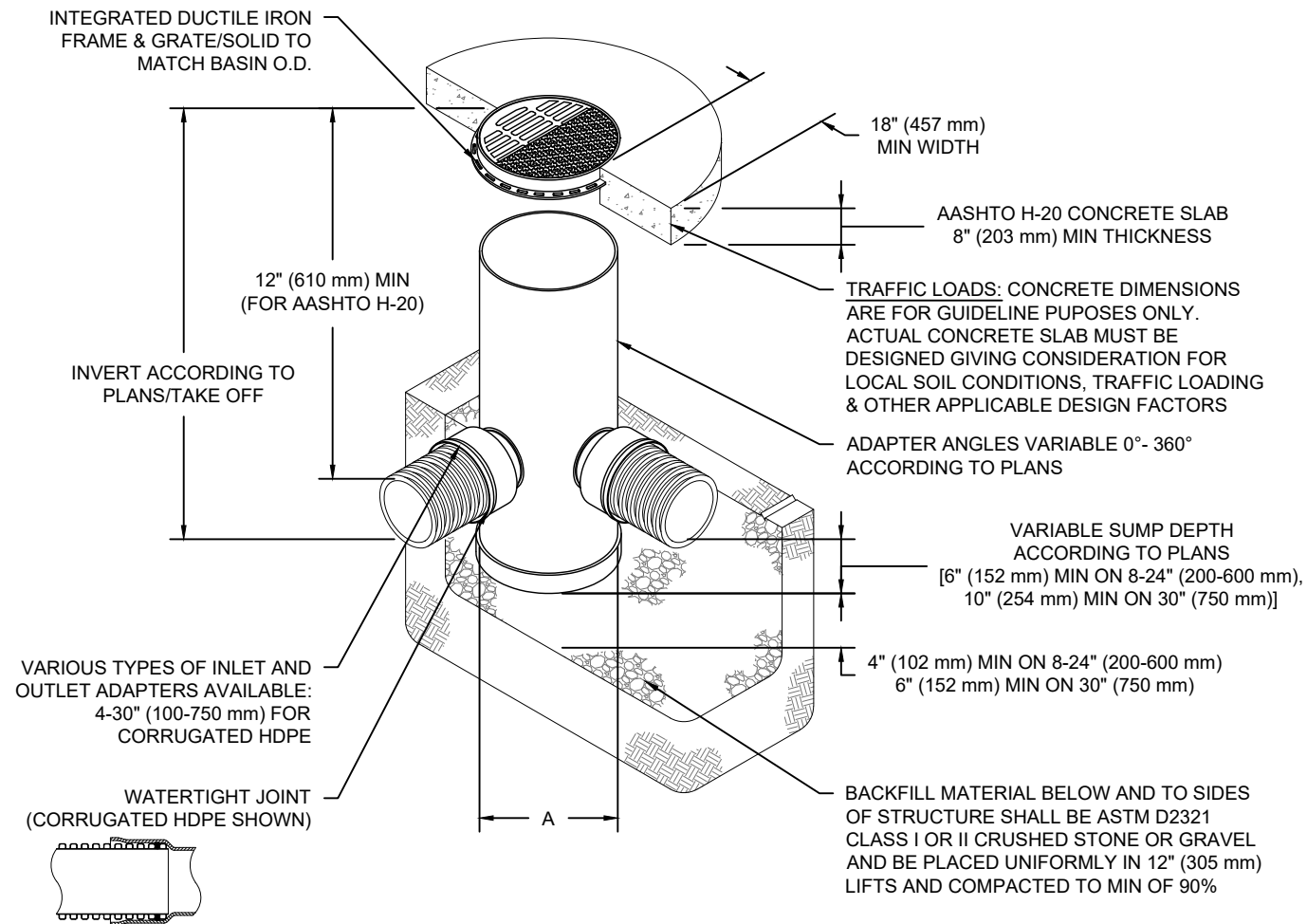

## NOTES

- 8-30" (200-750 mm) GRATES/SOLID COVERS SHALL BE DUCTILE IRON PER ASTM A536 GRADE 70-50-05
- 12-30" (300-750 mm) FRAMES SHALL BE DUCTILE IRON PER ASTM A536 GRADE 70-50-05
- DRAIN BASIN TO BE CUSTOM MANUFACTURED ACCORDING TO PLAN DETAILS
- DRAINAGE CONNECTION STUB JOINT TIGHTNESS SHALL CONFORM TO ASTM D3212 FOR CORRUGATED HDPE (ADS & HANCOR DUAL WALL) & SDR 35 PVC
- FOR COMPLETE DESIGN AND PRODUCT INFORMATION: [WWW.NYLOPLAST-US.COM](http://WWW.NYLOPLAST-US.COM)
- TO ORDER CALL: 800-821-6710

A	PART #	GRATE/SOLID COVER OPTIONS		
8" (200 mm)	2808AG	PEDESTRIAN LIGHT DUTY	STANDARD LIGHT DUTY	SOLID LIGHT DUTY
10" (250 mm)	2810AG	PEDESTRIAN LIGHT DUTY	STANDARD LIGHT DUTY	SOLID LIGHT DUTY
12" (300 mm)	2812AG	PEDESTRIAN AASHTO H-10	STANDARD AASHTO H-20	SOLID AASHTO H-20
15" (375 mm)	2815AG	PEDESTRIAN AASHTO H-10	STANDARD AASHTO H-20	SOLID AASHTO H-20
18" (450 mm)	2818AG	PEDESTRIAN AASHTO H-10	STANDARD AASHTO H-20	SOLID AASHTO H-20
24" (600 mm)	2824AG	PEDESTRIAN AASHTO H-10	STANDARD AASHTO H-20	SOLID AASHTO H-20
30" (750 mm)	2830AG	PEDESTRIAN AASHTO H-20	STANDARD AASHTO H-20	SOLID AASHTO H-20

220536 - 5254 BANK STREET

OTTAWA, ON, CANADA

DATE: 06/27/2025

DRAWN: UU

CHECKED: N/A

PROJECT #:

DESCRIPTION

CHK

DATE

DRW

DATE

CHK

770-932-2443 | WWW.NYLOPLAST-US.COM  
 THIS DRAWING HAS BEEN PREPARED BASED ON INFORMATION PROVIDED TO ADS/STORMTECH UNDER THE DIRECTION OF THE PROJECT'S ENGINEER OF RECORD (EOR) OR OTHER PROJECT REPRESENTATIVE. THIS DRAWING IS NOT INTENDED FOR USE IN BIDDING OR CONSTRUCTION WITHOUT THE EOR'S PRIOR APPROVAL. EOR SHALL REVIEW THIS DRAWING PRIOR TO BIDDING AND/OR CONSTRUCTION. IT IS THE ULTIMATE RESPONSIBILITY OF THE EOR TO ENSURE THAT THE PRODUCT(S) DEPICTED AND ALL ASSOCIATED DETAILS MEET ALL APPLICABLE LAWS, REGULATIONS, AND PROJECT REQUIREMENTS.

**Nyloplast**<sup>®</sup>

4640 TRUEMAN BLVD  
 HILLIARD, OH 43026  
 1-800-733-7473



SHEET

6 OF 6

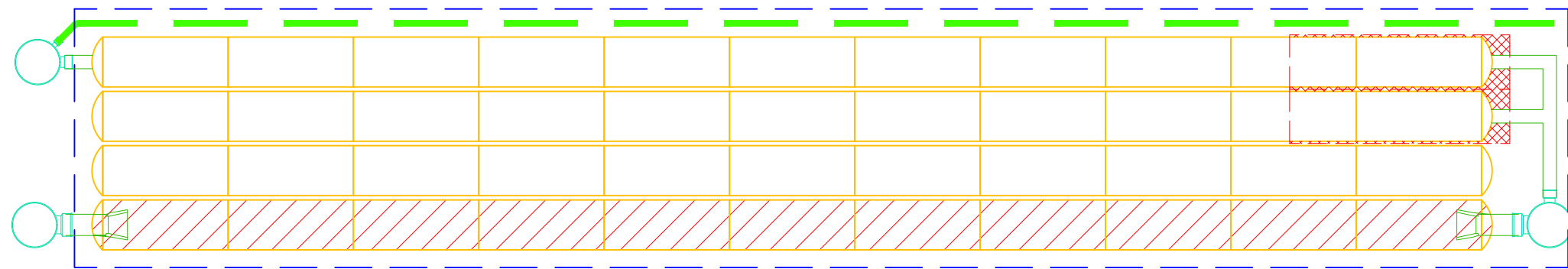

PROPOSED LAYOUT		CONCEPTUAL ELEVATIONS		PART TYPE		ITEM ON LAYOUT		DESCRIPTION		*INVERT ABOVE BASE OF CHAMBER	
44	STORMTECH SC-310 CHAMBERS	MAXIMUM ALLOWABLE GRADE (TOP OF PAVEMENT/UNPAVED)	2.997								
8	STORMTECH SC-310 END CAPS	MINIMUM ALLOWABLE GRADE (UNPAVED WITH TRAFFIC)	1.118								
152	STONE ABOVE (mm)	MINIMUM ALLOWABLE GRADE (UNPAVED NO TRAFFIC)	0.965								
152	STONE BELOW (mm)	MINIMUM ALLOWABLE GRADE (TOP OF RIGID CONCRETE PAVEMENT)	0.965								
40	STONE VOID	MINIMUM ALLOWABLE GRADE (BASE OF FLEXIBLE PAVEMENT)	0.965								
43.9	INSTALLED SYSTEM VOLUME (m <sup>3</sup> ) (PERIMETER STONE INCLUDED) (COVER STONE INCLUDED) (BASE STONE INCLUDED)	TOP OF STONE:	0.711								
115.7	SYSTEM AREA (m <sup>2</sup> )	TOP OF SC-310 CHAMBER:	0.358								
60.6	SYSTEM PERIMETER (m)	200 mm x 200 mm TOP MANFOLD INVERT:	0.241								
		300 mm ISOLATOR ROW PLUS INVERT:	0.175								
		200 mm BOTTOM CONNECTION INVERT:	0.168								
		BOTTOM OF SC-310 CHAMBER:	0.152								
		UNDERDRAIN INVERT:	0.033								
		BOTTOM OF STONE:	0.000								
		NYLOPLAST (INLET W/ISO PLUS ROW)									50 L/s IN
		NYLOPLAST (OUTLET)									20 L/s OUT
		UNDERDRAIN									

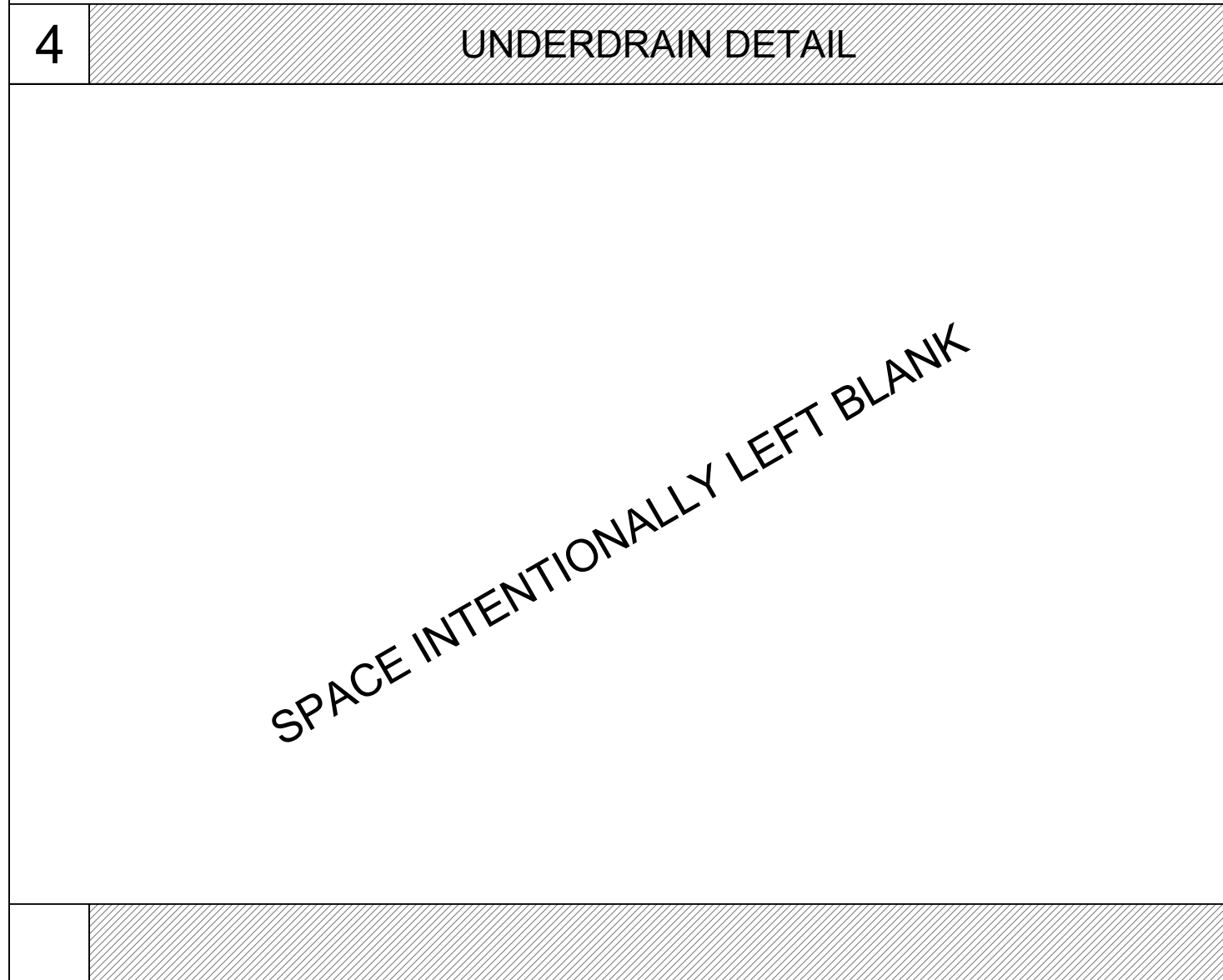
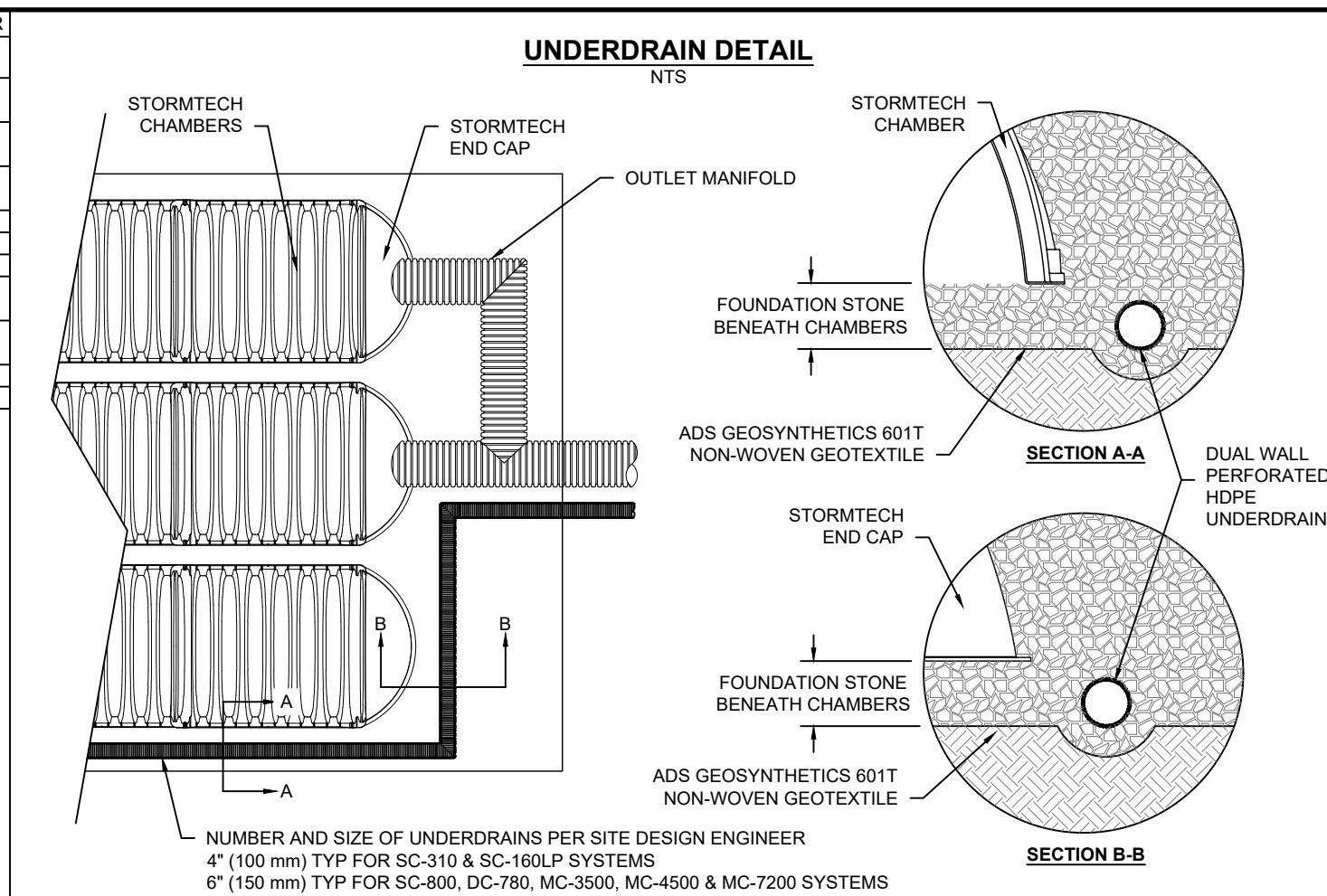
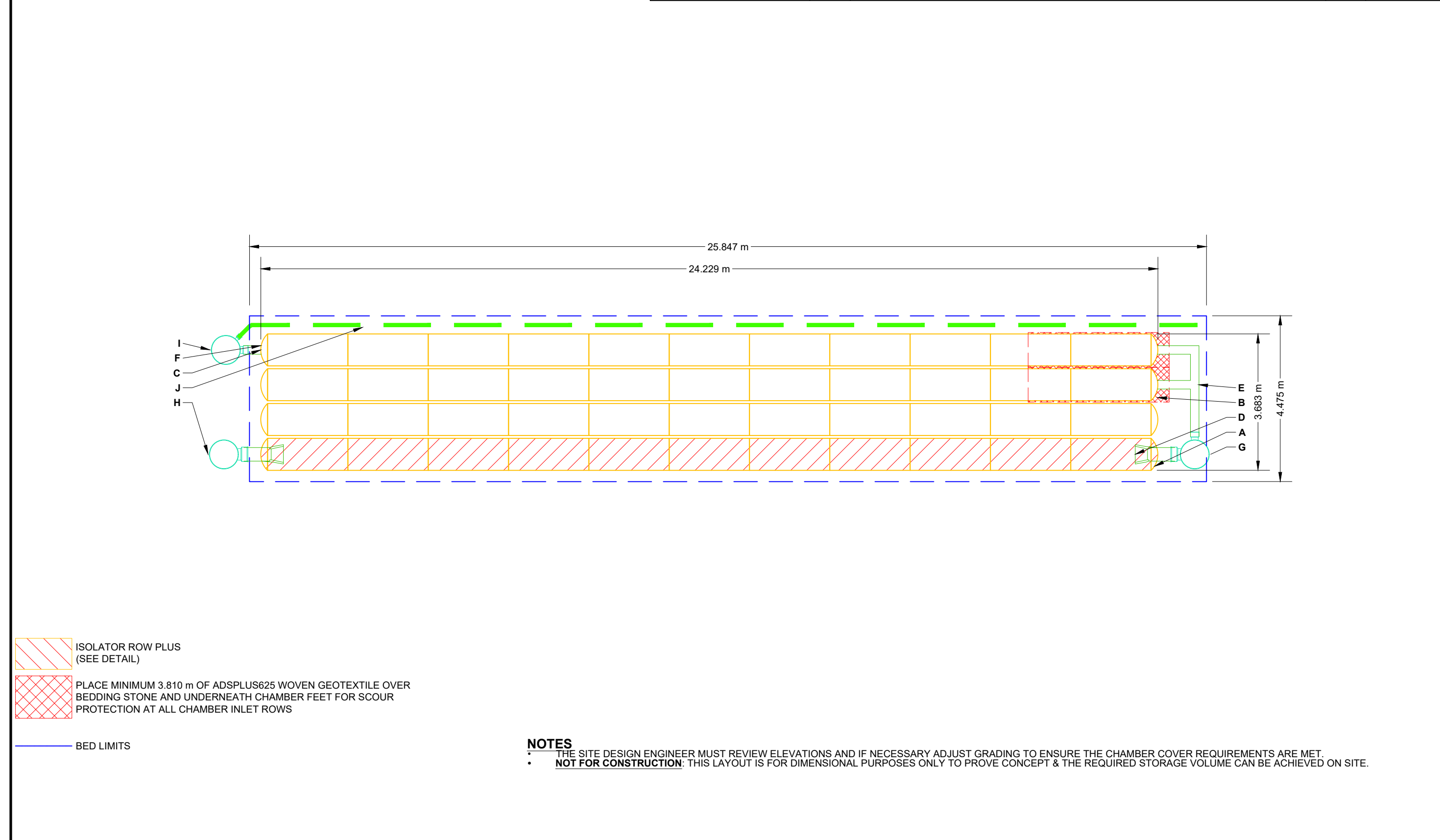

NOMINAL CHAMBER SPECIFICATIONS			
SIZE (W X H X INSTALLED LENGTH)	34.0\"/>		
CHAMBER STORAGE	14.7 CUBIC FEET (0.42 m <sup>3</sup> )		
MINIMUM INSTALLED STORAGE*	29.3 CUBIC FEET (0.83 m <sup>3</sup> )		
WEIGHT	38.0 lbs (16.8 kg)		

\*ASSUMES 6\"/>

PART #	STUB	B	C
SC310EPE06TPC	6\"/>		
SC310EPE06BPC	---	5.8\"/>	
SC310EPE08TPC	8\"/>		
SC310EPE08BPC	---	3.5\"/>	
SC310EPE10TPC	10\"/>		
SC310EPE10BPC	---	1.4\"/>	
SC310ECEZ*	12\"/>		

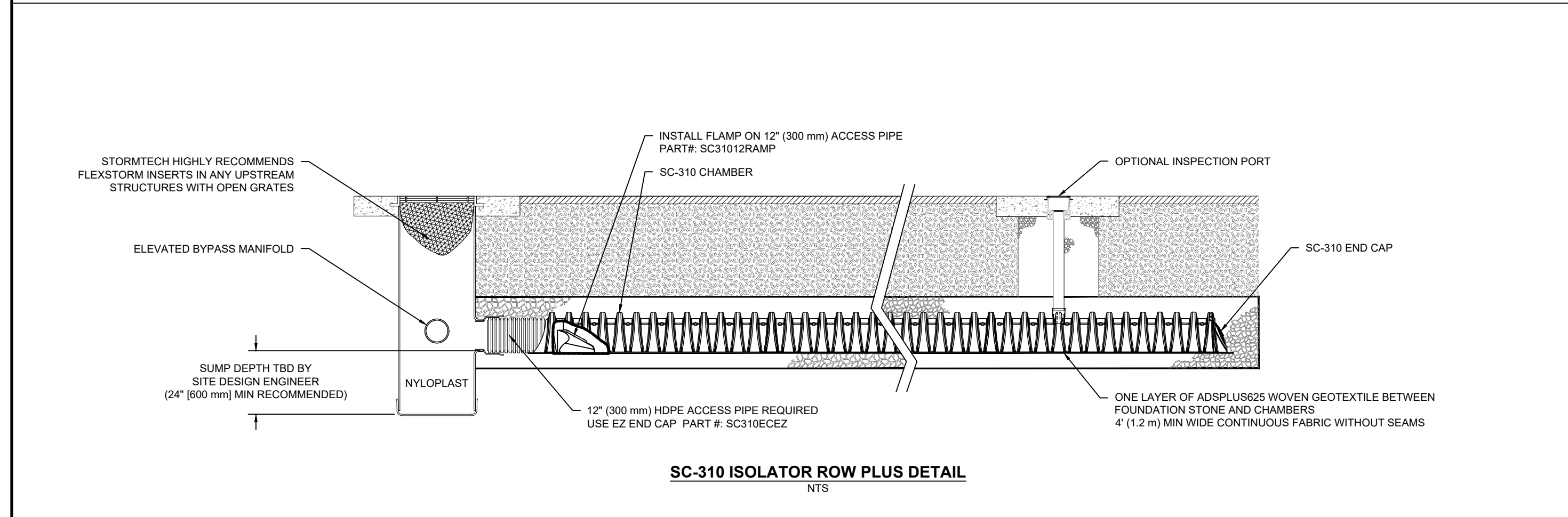
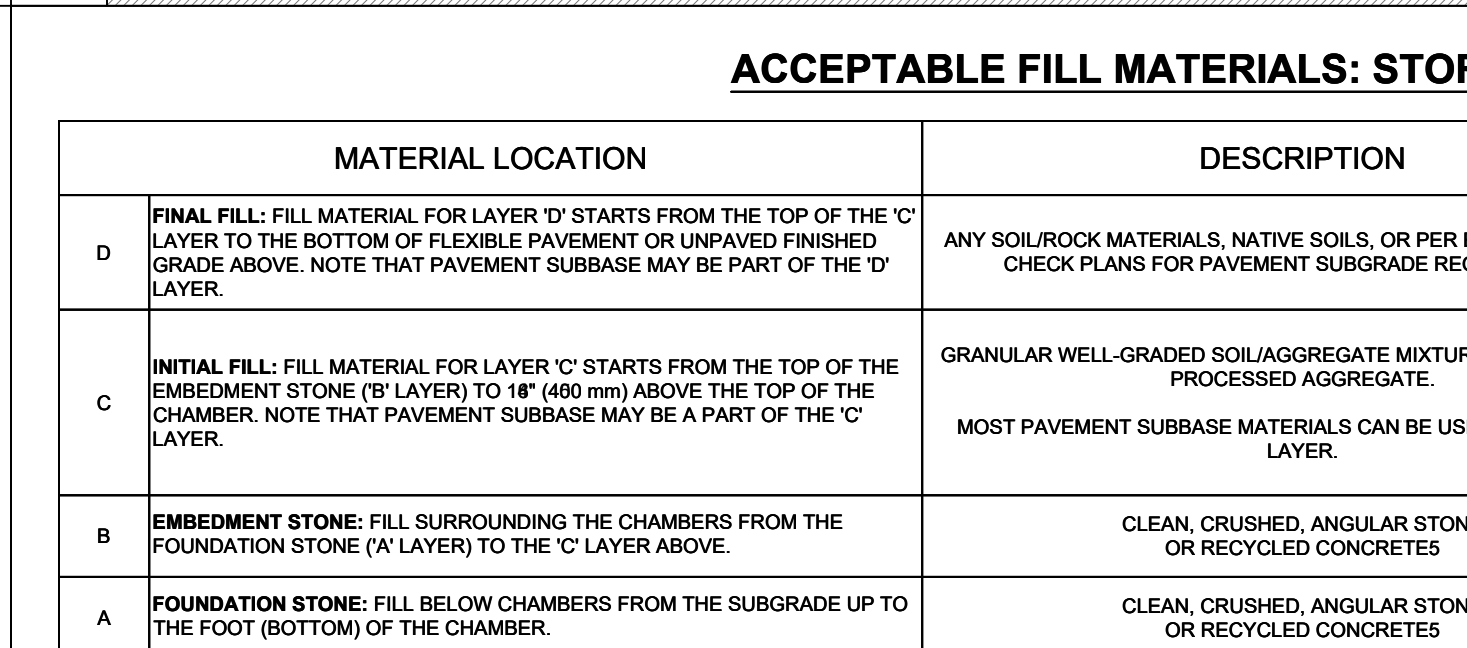

INSPECTION & MAINTENANCE	
STEP 1)	INSPECT ISOLATOR ROW PLUS FOR SEDIMENT A. INSPECTION PORTS (IF PRESENT) A.1. REMOVE/OPEN LID ON NYLOPLAST INLINE DRAIN A.2. REMOVE AND CLEAN FLEXSTORM FILTER IF INSTALLED A.3. USING A FLASHLIGHT AND STADIA ROD, MEASURE DEPTH OF SEDIMENT AND RECORD ON MAINTENANCE LOG A.4. LOWER A CAMERA INTO ISOLATOR ROW PLUS FOR VISUAL INSPECTION OF SEDIMENT LEVELS (OPTIONAL) A.5. IF SEDIMENT IS AT, OR ABOVE, 3\"/>
STEP 2)	CLEAN OUT ISOLATOR ROW PLUS USING THE JETVAC PROCESS A. A FIXED CULVERT CLEANING NOZZLE WITH REAR FACING SPREAD OF 45\"/>
STEP 3)	REPLACE ALL COVERS, GRATES, FILTERS, AND LIDS; RECORD OBSERVATIONS AND ACTIONS.
STEP 4)	INSPECT AND CLEAN BASINS AND MANHOLES UPSTREAM OF THE STORMTECH SYSTEM.

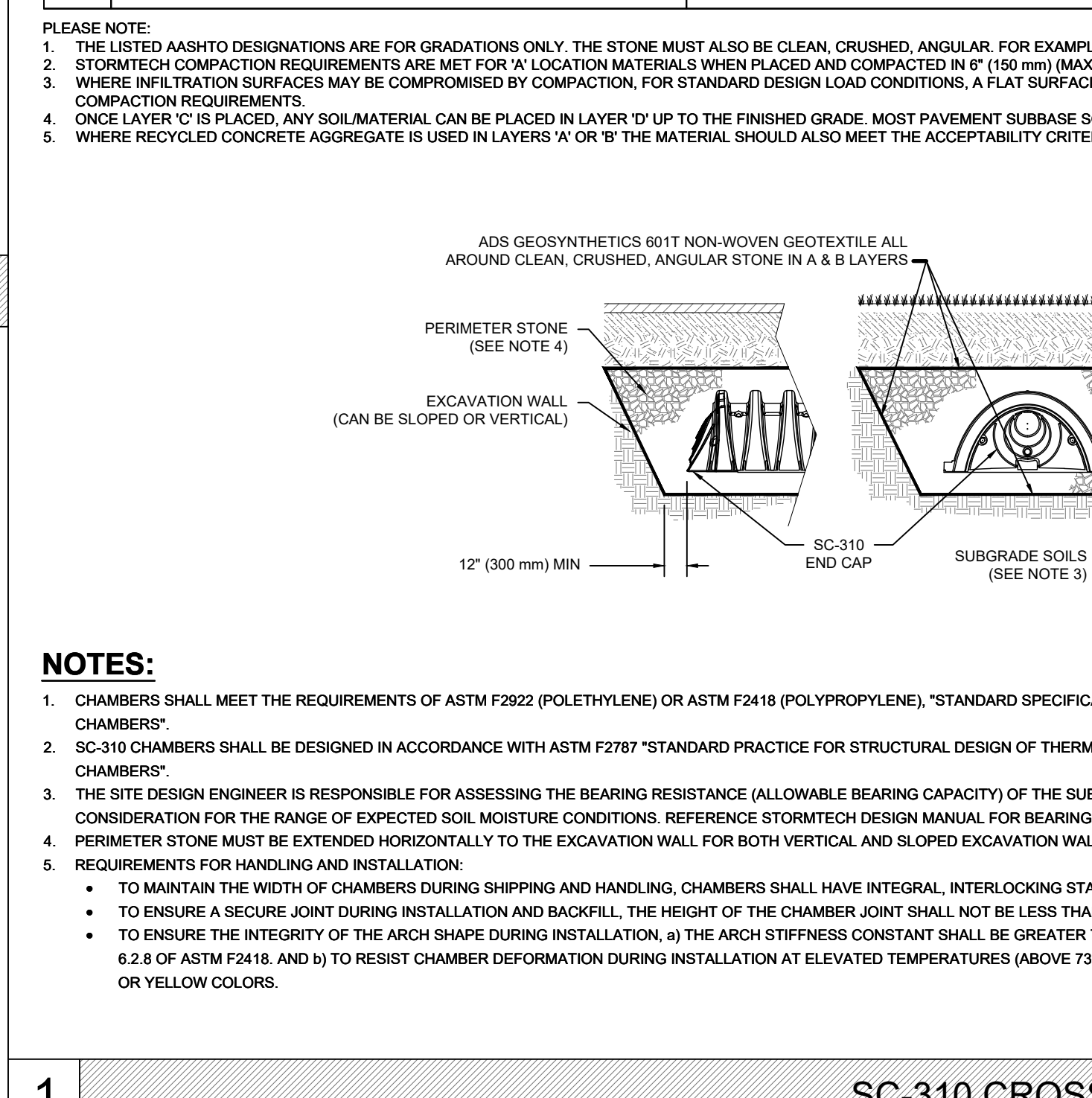

NOTES:	
1.	CHAMBERS SHALL MEET THE REQUIREMENTS OF ASTM F2922 (POLETHYLENE) OR ASTM F2418 (POLYPROPYLENE), "STANDARD SPECIFICATION FOR CORRUGATED WALL STORMWATER COLLECTION CHAMBERS".
2.	SC-310 CHAMBERS SHALL BE DESIGNED IN ACCORDANCE WITH ASTM F2787 "STANDARD PRACTICE FOR STRUCTURAL DESIGN OF THERMOPLASTIC CORRUGATED WALL STORMWATER COLLECTION CHAMBERS".
3.	THE SITE DESIGN ENGINEER IS RESPONSIBLE FOR ASSESSING THE BEARING RESISTANCE (ALLOWABLE BEARING CAPACITY) OF THE SUBGRADE SOILS AND THE DEPTH OF FOUNDATION STONE WITH CONSIDERATION FOR THE RANGE OF EXPECTED SOIL MOISTURE CONDITIONS. REFERENCE STORMTECH DESIGN MANUAL FOR BEARING CAPACITY GUIDANCE.
4.	PERIMETER STONE MUST BE EXTENDED HORIZONTALLY TO THE EXCAVATION WALL FOR BOTH VERTICAL AND SLOPED EXCAVATION WALLS.
5.	REQUIREMENTS FOR HANDLING AND INSTALLATION: • TO MAINTAIN THE WIDTH OF CHAMBERS DURING SHIPPING AND HANDLING, CHAMBERS SHALL HAVE INTEGRAL, INTERLOCKING STACKING LUGS. • TO ENSURE A SECURE JOINT DURING INSTALLATION AND BACKFILL, THE HEIGHT OF THE CHAMBER JOINT SHALL NOT BE LESS THAN 2". • TO ENSURE THE INTEGRITY OF THE ARCH SHAPE DURING INSTALLATION, THE ARCH STIFFNESS CONSTANT SHALL BE GREATER THAN OR EQUAL TO 325 LBS/FT <sup>2</sup> . THE ASC IS DEFINED IN SECTION 6.2.8 OF ASTM F2418. AND b) TO RESIST CHAMBER DEFORMATION DURING INSTALLATION AT ELEVATED TEMPERATURES (ABOVE 73° F / 23° C), CHAMBERS SHALL BE PRODUCED FROM REFLECTIVE GOLD OR YELLOW COLORS.

DATE: 06/27/2025  
PROJECT #: NOT TO SCALE  
DRAWN: UU  
CHECKED: N/A  
REV: NOT TO SCALE

220536 - 5254 BANK STREET  
OTTAWA, ON, CANADA

StormTech Chamber System  
4640 TRUJEMAN BLVD  
HILLIARD, OH 43026  
1-800-733-7473

THIS DRAWING HAS BEEN PREPARED BASED ON INFORMATION PROVIDED TO ADS/STORMTECH UNDER THE DIRECTION OF THE PROJECT'S ENGINEER OF RECORD (EOR) OR OTHER PROJECT REPRESENTATIVE. THIS DRAWING IS NOT INTENDED FOR USE IN BIDDING OR CONSTRUCTION WITHOUT THE EOR'S PRIOR APPROVAL. EOR SHALL REVIEW THIS DRAWING PRIOR TO BIDDING AND/OR CONSTRUCTION. IT IS THE ULTIMATE RESPONSIBILITY OF THE EOR TO ENSURE THAT THE PRODUCT(S) DEPICTED AND ALL ASSOCIATED DETAILS MEET ALL APPLICABLE LAWS, REGULATIONS, AND PROJECT REQUIREMENTS.

SHEET 1 OF 1

## Stormceptor® EF Sizing Report

### Imbrium® Systems

#### ESTIMATED NET ANNUAL SEDIMENT (TSS) LOAD REDUCTION

06/27/2025

Province:	Ontario	Project Name:	5254 Bank Street SPC
City:	Ottawa	Project Number:	220536-02
Nearest Rainfall Station:	OTTAWA CDA RCS	Designer Name:	Kyle Herold
Climate Station Id:	6105978	Designer Company:	LRL Associates
Years of Rainfall Data:	20	Designer Email:	kherold@lrl.ca
Site Name:	Driveway / Parking Lot	Designer Phone:	613-915-2988
Drainage Area (ha):	0.13	EOR Name:	
Runoff Coefficient 'c':	0.71	EOR Company:	
Particle Size Distribution:	Fine	EOR Email:	
Target TSS Removal (%):	80.0	EOR Phone:	

Required Water Quality Runoff Volume Capture (%):	90.00
Estimated Water Quality Flow Rate (L/s):	2.98
Oil / Fuel Spill Risk Site?	Yes
Upstream Flow Control?	Yes
Upstream Orifice Control Flow Rate to Stormceptor (L/s):	12.00
Peak Conveyance (maximum) Flow Rate (L/s):	
Influent TSS Concentration (mg/L):	200
Estimated Average Annual Sediment Load (kg/yr):	118
Estimated Average Annual Sediment Volume (L/yr):	96

Net Annual Sediment (TSS) Load Reduction Sizing Summary	
Stormceptor Model	TSS Removal Provided (%)
EFO4	98
EFO5	99
EFO6	100
EFO8	100
EFO10	100

**Recommended Stormceptor EFO Model: EFO4**  
**Estimated Net Annual Sediment (TSS) Load Reduction (%): 98**  
**Water Quality Runoff Volume Capture (%): > 90**



### THIRD-PARTY TESTING AND VERIFICATION

► **Stormceptor® EF and Stormceptor® EFO** are the latest evolutions in the Stormceptor® oil-grit separator (OGS) technology series, and are designed to remove a wide variety of pollutants from stormwater and snowmelt runoff. These technologies have been third-party tested in accordance with the Canadian ETV **Procedure for Laboratory Testing of Oil-Grit Separators** and performance has been third-party verified in accordance with the **ISO 14034 Environmental Technology Verification (ETV)** protocol.

### PERFORMANCE

► **Stormceptor® EF and EFO** remove stormwater pollutants through gravity separation and floatation, and feature a patent-pending design that generates positive removal of total suspended solids (TSS) throughout each storm event, including high-intensity storms. Captured pollutants include sediment, free oils, and sediment-bound pollutants such as nutrients, heavy metals, and petroleum hydrocarbons. Stormceptor is sized to remove a high level of TSS from the frequent rainfall events that contribute the vast majority of annual runoff volume and pollutant load. The technology incorporates an internal bypass to convey excessive stormwater flows from high-intensity storms through the device without resuspension and washout (scour) of previously captured pollutants. Proper routine maintenance ensures high pollutant removal performance and protection of downstream waterways.

### PARTICLE SIZE DISTRIBUTION (PSD)

► The **Canadian ETV PSD** shown in the table below was used, or in part, for this sizing. This is the identical PSD that is referenced in the Canadian ETV **Procedure for Laboratory Testing of Oil-Grit Separators** for both sediment removal testing and scour testing. The Canadian ETV PSD contains a wide range of particle sizes in the sand and silt fractions, and is considered reasonably representative of the particle size fractions found in typical urban stormwater runoff.

Particle Size (µm)	Percent Less Than	Particle Size Fraction (µm)	Percent
1000	100	500-1000	5
500	95	250-500	5
250	90	150-250	15
150	75	100-150	15
100	60	75-100	10
75	50	50-75	5
50	45	20-50	10
20	35	8-20	15
8	20	5-8	10
5	10	2-5	5
2	5	<2	5

## Stormceptor® EF Sizing Report

### Upstream Flow Controlled Results

Rainfall Intensity (mm / hr)	Percent Rainfall Volume (%)	Cumulative Rainfall Volume (%)	Flow Rate (L/s)	Flow Rate (L/min)	Surface Loading Rate (L/min/m²)	Removal Efficiency (%)	Incremental Removal (%)	Cumulative Removal (%)
0.50	8.6	8.6	0.13	8.0	6.0	100	8.6	8.6
1.00	20.3	29.0	0.26	15.0	13.0	100	20.3	29.0
2.00	16.2	45.2	0.51	31.0	26.0	100	16.2	45.2
3.00	12.0	57.2	0.77	46.0	38.0	100	12.0	57.2
4.00	8.4	65.6	1.03	62.0	51.0	100	8.4	65.6
5.00	5.9	71.6	1.28	77.0	64.0	100	5.9	71.6
6.00	4.6	76.2	1.54	92.0	77.0	100	4.6	76.2
7.00	3.1	79.3	1.80	108.0	90.0	97	3.0	79.2
8.00	2.7	82.0	2.05	123.0	103.0	96	2.6	81.8
9.00	3.3	85.3	2.31	139.0	115.0	95	3.2	85.0
10.00	2.3	87.6	2.57	154.0	128.0	93	2.1	87.1
11.00	1.6	89.2	2.82	169.0	141.0	91	1.4	88.5
12.00	1.3	90.5	3.08	185.0	154.0	89	1.2	89.7
13.00	1.7	92.2	3.34	200.0	167.0	88	1.5	91.2
14.00	1.2	93.5	3.59	216.0	180.0	86	1.1	92.3
15.00	1.2	94.6	3.85	231.0	192.0	84	1.0	93.2
16.00	0.7	95.3	4.11	246.0	205.0	83	0.6	93.8
17.00	0.7	96.1	4.36	262.0	218.0	83	0.6	94.4
18.00	0.4	96.5	4.62	277.0	231.0	82	0.3	94.8
19.00	0.4	96.9	4.88	293.0	244.0	81	0.3	95.1
20.00	0.2	97.1	5.13	308.0	257.0	81	0.2	95.3
21.00	0.5	97.5	5.39	323.0	269.0	80	0.4	95.6
22.00	0.2	97.8	5.65	339.0	282.0	79	0.2	95.8
23.00	1.0	98.8	5.90	354.0	295.0	79	0.8	96.6
24.00	0.3	99.1	6.16	369.0	308.0	78	0.2	96.8
25.00	0.9	100.0	6.41	385.0	321.0	78	0.7	97.6
30.00	0.9	100.9	7.70	462.0	385.0	75	0.7	98.3
35.00	-0.9	100.0	8.98	539.0	449.0	72	N/A	97.6
40.00	0.0	100.0	10.26	616.0	513.0	69	0.0	97.6
45.00	0.0	100.0	11.55	693.0	577.0	66	0.0	97.6
<b>Estimated Net Annual Sediment (TSS) Load Reduction =</b>								<b>98 %</b>

Climate Station ID: 6105978 Years of Rainfall Data: 20

## Stormceptor® EF Sizing Report

### RAINFALL DATA FROM OTTAWA CDA RCS RAINFALL STATION

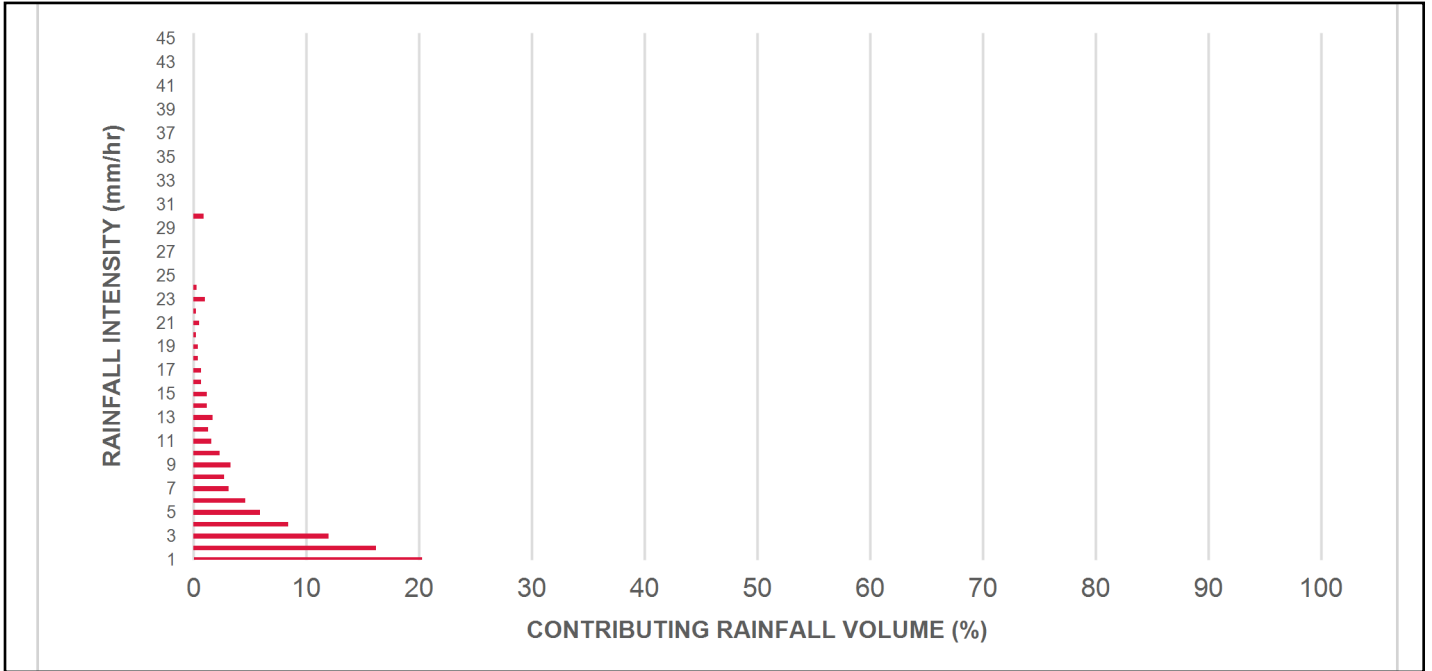

### INCREMENTAL AND CUMULATIVE TSS REMOVAL FOR THE RECOMMENDED STORMCEPTOR® MODEL

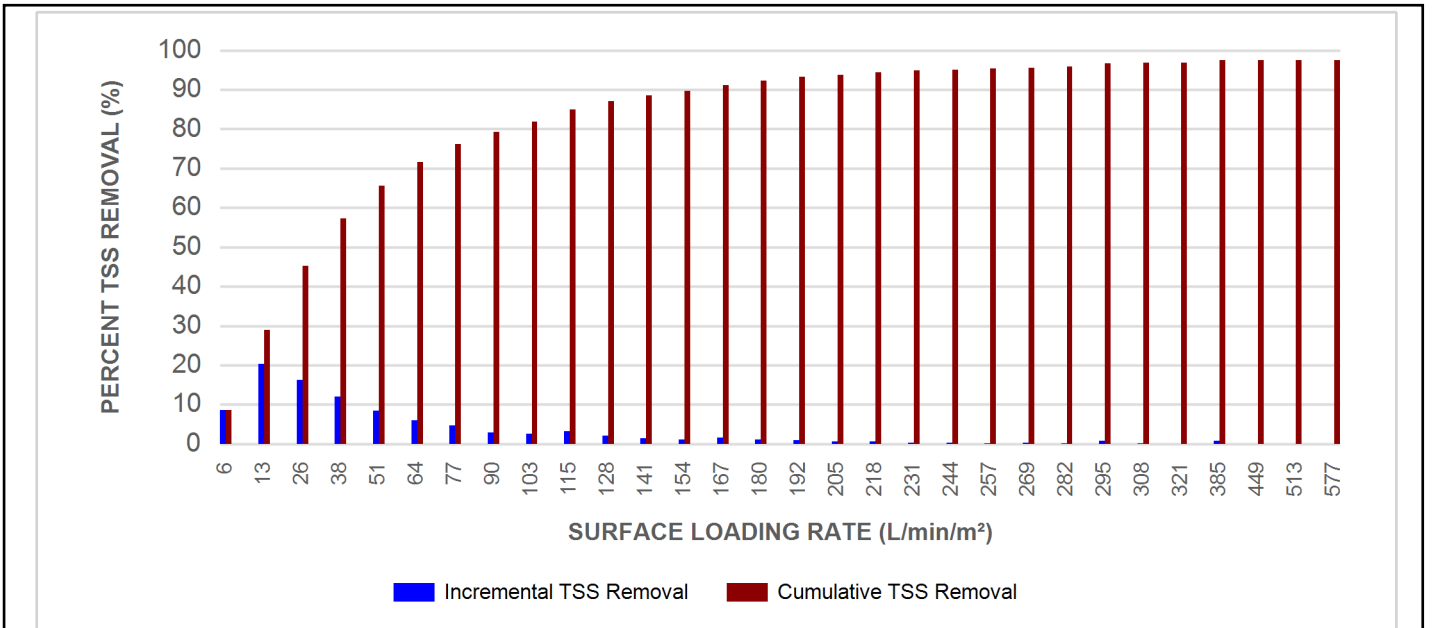

## Stormceptor® EF Sizing Report

### Maximum Pipe Diameter / Peak Conveyance

Stormceptor EF / EFO	Model Diameter		Min Angle Inlet / Outlet Pipes	Max Inlet Pipe Diameter		Max Outlet Pipe Diameter		Peak Conveyance Flow Rate	
	(m)	(ft)		(mm)	(in)	(mm)	(in)	(L/s)	(cfs)
EF4 / EFO4	1.2	4	90	609	24	609	24	425	15
EF5 / EFO5	1.5	5	90	762	30	762	30	710	25
EF6 / EFO6	1.8	6	90	914	36	914	36	990	35
EF8 / EFO8	2.4	8	90	1219	48	1219	48	1700	60
EF10 / EFO10	3.0	10	90	1828	72	1828	72	2830	100
EF12 / EFO12	3.6	12	90	1828	72	1828	72	2830	100

### SCOUR PREVENTION AND ONLINE CONFIGURATION

► Stormceptor® EF and EFO feature an internal bypass and superior scour prevention technology that have been demonstrated in third-party testing according to the scour testing provisions of the Canadian ETV **Procedure for Laboratory Testing of Oil-Grit Separators**, and the exceptional scour test performance has been third-party verified in accordance with the ISO 14034 ETV protocol. As a result, Stormceptor EF and EFO are approved for online installation, eliminating the need for costly additional bypass structures, piping, and installation expense.

### DESIGN FLEXIBILITY

► Stormceptor® EF and EFO offers design flexibility in one simplified platform, accepting stormwater flow from a single inlet pipe or multiple inlet pipes, and/or surface runoff through an inlet grate. The device can also serve as a junction structure, accommodate a 90-degree inlet-to-outlet bend angle, and can be modified to ensure performance in submerged conditions.

### OIL CAPTURE AND RETENTION

► While Stormceptor® EF will capture and retain oil from dry weather spills and low intensity runoff, Stormceptor® EFO has demonstrated superior oil capture and greater than 99% oil retention in third-party testing according to the light liquid re-entrainment testing provisions of the Canadian ETV **Procedure for Laboratory Testing of Oil-Grit Separators**. Stormceptor EFO is recommended for sites where oil capture and retention is a requirement.

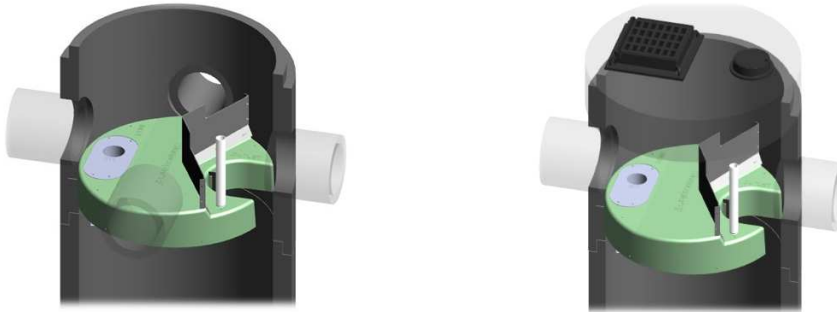

## Stormceptor® EF Sizing Report

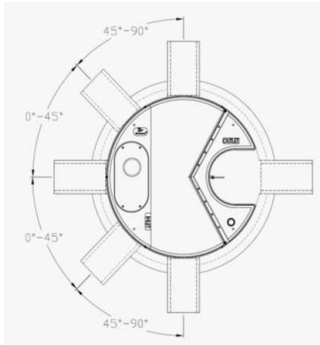

### INLET-TO-OUTLET DROP

Elevation differential between inlet and outlet pipe inverts is dictated by the angle at which the inlet pipe(s) enters the unit.

0° - 45° : The inlet pipe is 1-inch (25mm) higher than the outlet pipe.

45° - 90° : The inlet pipe is 2-inches (50mm) higher than the outlet pipe.

### HEAD LOSS

The head loss through Stormceptor EF is similar to that of a 60-degree bend structure. The applicable K value for calculating minor losses through the unit is 1.1. For submerged conditions the applicable K value is 3.0.

### Pollutant Capacity

Stormceptor EF / EFO	Model Diameter		Depth (Outlet Pipe Invert to Sump Floor)		Oil Volume		Recommended Sediment Maintenance Depth *		Maximum Sediment Volume *		Maximum Sediment Mass **	
	(m)	(ft)	(m)	(ft)	(L)	(Gal)	(mm)	(in)	(L)	(ft³)	(kg)	(lb)
EF4 / EFO4	1.2	4	1.52	5.0	265	70	203	8	1190	42	1904	5250
EF5 / EFO5	1.5	5	1.62	5.3	420	111	305	10	2124	75	2612	5758
EF6 / EFO6	1.8	6	1.93	6.3	610	160	305	12	3470	123	5552	15375
EF8 / EFO8	2.4	8	2.59	8.5	1070	280	610	24	8780	310	14048	38750
EF10 / EFO10	3.0	10	3.25	10.7	1670	440	610	24	17790	628	28464	78500
EF12 / EFO12	3.6	12	3.89	12.8	2475	655	610	24	31220	1103	49952	137875

\*Increased sump depth may be added to increase sediment storage capacity

\*\* Average density of wet packed sediment in sump = 1.6 kg/L (100 lb/ft³)

Feature	Benefit	Feature Appeals To
Patent-pending enhanced flow treatment and scour prevention technology	Superior, verified third-party performance	Regulator, Specifying & Design Engineer
Third-party verified light liquid capture and retention for EFO version	Proven performance for fuel/oil hotspot locations	Regulator, Specifying & Design Engineer, Site Owner
Functions as bend, junction or inlet structure	Design flexibility	Specifying & Design Engineer
Minimal drop between inlet and outlet	Site installation ease	Contractor
Large diameter outlet riser for inspection and maintenance	Easy maintenance access from grade	Maintenance Contractor & Site Owner

### STANDARD STORMCEPTOR EF/EFO DRAWINGS

For standard details, please visit <http://www.imbriumsystems.com/stormwater-treatment-solutions/stormceptor-ef>

### STANDARD STORMCEPTOR EF/EFO SPECIFICATION

For specifications, please visit <http://www.imbriumsystems.com/stormwater-treatment-solutions/stormceptor-ef>

## STANDARD PERFORMANCE SPECIFICATION FOR “OIL GRIT SEPARATOR” (OGS) STORMWATER QUALITY TREATMENT DEVICE

### PART 1 – GENERAL

#### 1.1 WORK INCLUDED

This section specifies requirements for selecting, sizing, and designing an underground Oil Grit Separator (OGS) device for stormwater quality treatment, with third-party testing results and a Statement of Verification in accordance with ISO 14034 Environmental Management – Environmental Technology Verification (ETV).

#### 1.2 REFERENCE STANDARDS & PROCEDURES

ISO 14034:2016 Environmental management – Environmental technology verification (ETV)

Canadian Environmental Technology Verification (ETV) Program’s **Procedure for Laboratory Testing of Oil-Grit Separators**

#### 1.3 SUBMITTALS

1.3.1 All submittals, including sizing reports & shop drawings, shall be submitted upon request with each order to the contractor then forwarded to the Engineer of Record for review and acceptance. Shop drawings shall detail all OGS components, elevations, and sequence of construction.

1.3.2 Alternative devices shall have features identical to or greater than the specified device, including: treatment chamber diameter, treatment chamber wet volume, sediment storage volume, and oil storage volume.

1.3.3 Unless directed otherwise by the Engineer of Record, OGS stormwater quality treatment product substitutions or alternatives submitted within ten days prior to project bid shall not be accepted. All alternatives or substitutions submitted shall be signed and sealed by a local registered Professional Engineer, based on the exact same criteria detailed in Section 3, in entirety, subject to review and approval by the Engineer of Record.

### PART 2 – PRODUCTS

#### 2.1 OGS POLLUTANT STORAGE

The OGS device shall include a sump for sediment storage, and a protected volume for the capture and storage of petroleum hydrocarbons and buoyant gross pollutants. The minimum sediment & petroleum hydrocarbon storage capacity shall be as follows:

2.1.1	4 ft (1219 mm) Diameter OGS Units:	1.19 m <sup>3</sup> sediment / 265 L oil
	5 ft (1524 mm) Diameter OGS Units:	1.95 m <sup>3</sup> sediment / 420 L oil
	6 ft (1829 mm) Diameter OGS Units:	3.48 m <sup>3</sup> sediment / 609 L oil
	8 ft (2438 mm) Diameter OGS Units:	8.78 m <sup>3</sup> sediment / 1,071 L oil
	10 ft (3048 mm) Diameter OGS Units:	17.78 m <sup>3</sup> sediment / 1,673 L oil
	12 ft (3657 mm) Diameter OGS Units:	31.23 m <sup>3</sup> sediment / 2,476 L oil

### PART 3 – PERFORMANCE & DESIGN

## Stormceptor® EF Sizing Report

### 3.1 GENERAL

The OGS stormwater quality treatment device shall be verified in accordance with ISO 14034:2016 Environmental management – Environmental technology verification (ETV). The OGS stormwater quality treatment device shall remove oil, sediment and gross pollutants from stormwater runoff during frequent wet weather events, and retain these pollutants during less frequent high flow wet weather events below the insert within the OGS for later removal during maintenance. The Manufacturer shall have at least ten (10) years of local experience, history and success in engineering design, manufacturing and production and supply of OGS stormwater quality treatment device systems, acceptable to the Engineer of Record.

### 3.2 SIZING METHODOLOGY

The OGS device shall be engineered, designed and sized to provide stormwater quality treatment based on treating a minimum of 90 percent of the average annual runoff volume and a minimum removal of an annual average 60% of the sediment (TSS) load based on the Particle Size Distribution (PSD) specified in the sizing report for the specified device. Sizing of the OGS shall be determined by use of a minimum ten (10) years of local historical rainfall data provided by Environment Canada. Sizing shall also be determined by use of the sediment removal performance data derived from the ISO 14034 ETV third-party verified laboratory testing data from testing conducted in accordance with the Canadian ETV protocol Procedure for Laboratory Testing of Oil-Grit Separators, as follows:

3.2.1 Sediment removal efficiency for a given surface loading rate and its associated flow rate shall be based on sediment removal efficiency demonstrated at the seven (7) tested surface loading rates specified in the protocol, ranging 40 L/min/m<sup>2</sup> to 1400 L/min/m<sup>2</sup>, and as stated in the ISO 14034 ETV Verification Statement for the OGS device.

3.2.2 Sediment removal efficiency for surface loading rates between 40 L/min/m<sup>2</sup> and 1400 L/min/m<sup>2</sup> shall be based on linear interpolation of data between consecutive tested surface loading rates.

3.2.3 Sediment removal efficiency for surface loading rates less than the lowest tested surface loading rate of 40 L/min/m<sup>2</sup> shall be assumed to be identical to the sediment removal efficiency at 40 L/min/m<sup>2</sup>. No extrapolation shall be allowed that results in a sediment removal efficiency that is greater than that demonstrated at 40 L/min/m<sup>2</sup>.

3.2.4 Sediment removal efficiency for surface loading rates greater than the highest tested surface loading rate of 1400 L/min/m<sup>2</sup> shall assume zero sediment removal for the portion of flow that exceeds 1400 L/min/m<sup>2</sup>, and shall be calculated using a simple proportioning formula, with 1400 L/min/m<sup>2</sup> in the numerator and the higher surface loading rate in the denominator, and multiplying the resulting fraction times the sediment removal efficiency at 1400 L/min/m<sup>2</sup>.

The OGS device shall also have sufficient annual sediment storage capacity as specified and calculated in Section 2.1.

### 3.3 CANADIAN ETV or ISO 14034 ETV VERIFICATION OF SCOUR TESTING

The OGS device shall have Canadian ETV or ISO 14034 ETV Verification of third-party scour testing conducted in accordance with the Canadian ETV Program's **Procedure for Laboratory Testing of Oil-Grit Separators**.

3.3.1 To be acceptable for on-line installation, the OGS device must demonstrate an average scour test effluent concentration less than 10 mg/L at each surface loading rate tested, up to and including 2600 L/min/m<sup>2</sup>.

### 3.4 LIGHT LIQUID RE-ENTRAINMENT SIMULATION TESTING

The OGS device shall have Canadian ETV or ISO 14034 ETV Verification of completed third-party Light Liquid

## Stormceptor® EF Sizing Report

Re-entrainment Simulation Testing in accordance with the Canadian ETV **Program's Procedure for Laboratory Testing of Oil-Grit Separators**, with results reported within the Canadian ETV or ISO 14034 ETV verification. This re-entrainment testing is conducted with the device pre-loaded with low density polyethylene (LDPE) plastic beads as a surrogate for light liquids such as oil and fuel. Testing is conducted on the same OGS unit tested for sediment removal to assess whether light liquids captured after a spill are effectively retained at high flow rates.

3.4.1 For an OGS device to be an acceptable stormwater treatment device on a site where vehicular traffic occurs and the potential for an oil or fuel spill exists, the OGS device must have reported verified performance results of greater than 99% cumulative retention of LDPE plastic beads for the five specified surface loading rates (ranging 200 L/min/m<sup>2</sup> to 2600 L/min/m<sup>2</sup>) in accordance with the Light Liquid Re-entrainment Simulation Testing within the Canadian ETV Program's **Procedure for Laboratory Testing of Oil-Grit Separators**. However, an OGS device shall not be allowed if the Light Liquid Re-entrainment Simulation Testing was performed with screening components within the OGS device that are effective at retaining the LDPE plastic beads, but would not be expected to retain light liquids such as oil and fuel.





# VHV Vertical Vortex Flow Regulator

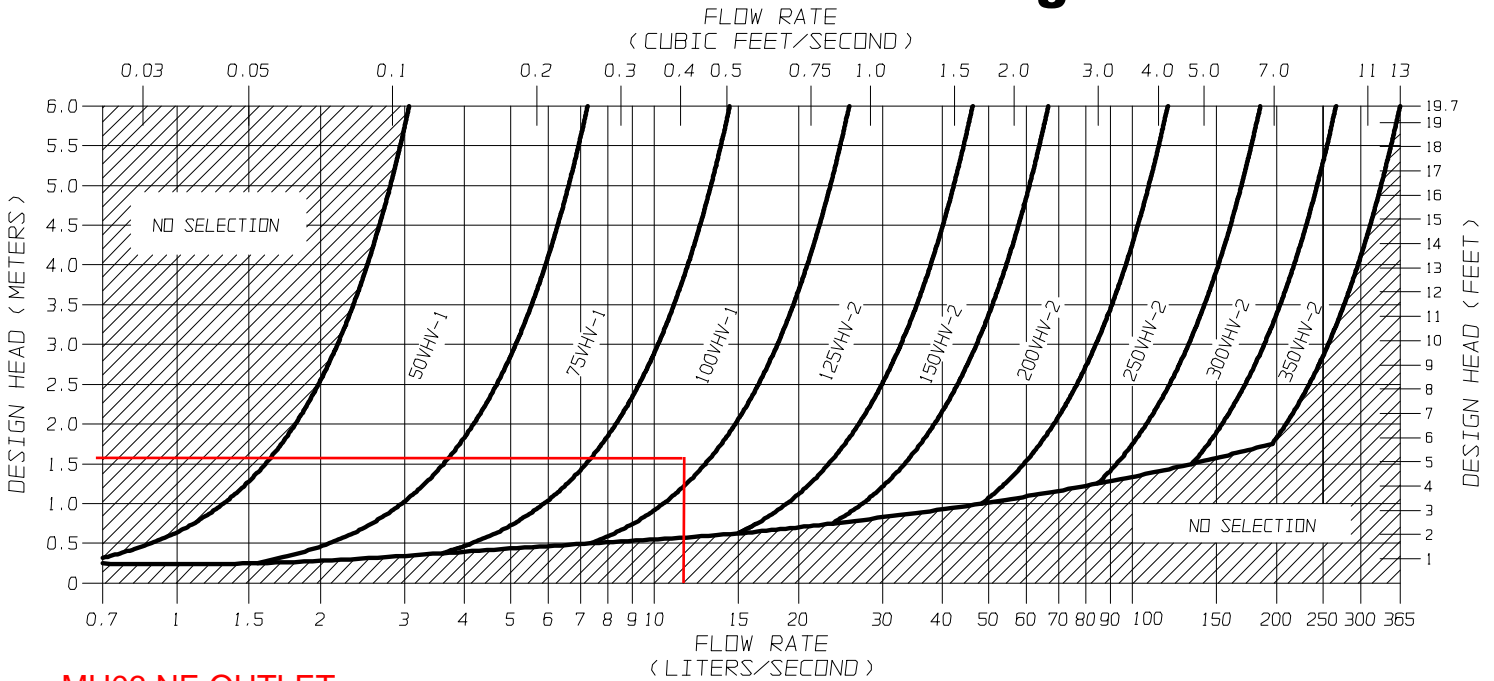

MH03 NE OUTLET  
HYDROVEX 100VHV-1  
DESIGN HEAD = 1.61m  
MAX FLOW RATE = 12.00 L/s

FIGURE 3 - VHV

**JOHN MEUNIER**



**HYDROVEX<sup>®</sup> VHV / SVHV**  
**Vertical Vortex Flow Regulator**

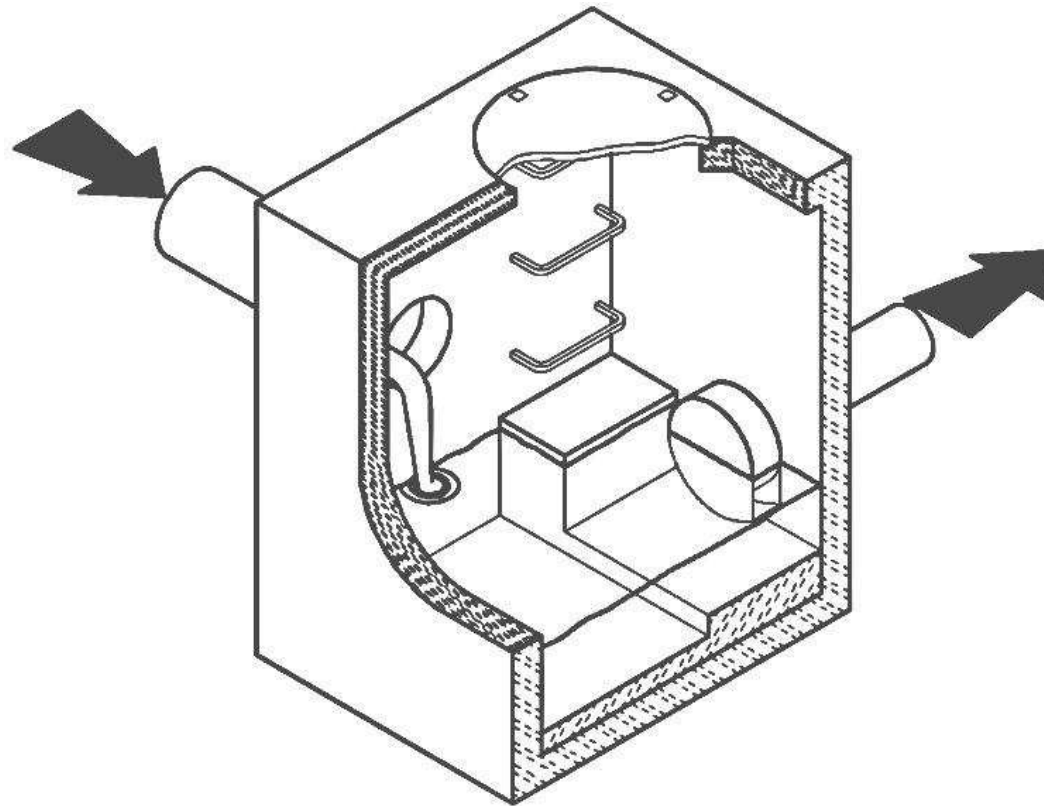

**JOHN MEUNIER**

# HYDROVEX® VHV / SVHV VERTICAL VORTEX FLOW REGULATOR

## APPLICATIONS

One of the major problems of urban wet weather flow management is the runoff generated after a heavy rainfall. During a storm, uncontrolled flows may overload the drainage system and cause flooding. Due to increased velocities, sewer pipe wear is increased dramatically and results in network deterioration. In a combined sewer system, the wastewater treatment plant may also experience significant increases in flows during storms, thereby losing its treatment efficiency.

A simple means of controlling excessive water runoff is by controlling excessive flows at their origin (manholes). **John Meunier Inc.** manufactures the **HYDROVEX® VHV / SVHV** line of vortex flow regulators to control stormwater flows in sewer networks, as well as manholes.

The vortex flow regulator design is based on the fluid mechanics principle of the forced vortex. This grants flow regulation without any moving parts, thus reducing maintenance. The operation of the regulator, depending on the upstream head and discharge, switches between orifice flow (gravity flow) and vortex flow. Although the concept is quite simple, over 12 years of research have been carried out in order to get a high performance.

The **HYDROVEX® VHV / SVHV** Vertical Vortex Flow Regulators (**refer to Figure 1**) are manufactured entirely of stainless steel, and consist of a hollow body (1) in which flow control takes place and an outlet orifice (7). Two rubber "O" rings (3) seal and retain the unit inside the outlet pipe. Two stainless steel retaining rings (4) are welded on the outlet sleeve to ensure that there is no shifting of the "O" rings during installation and use.

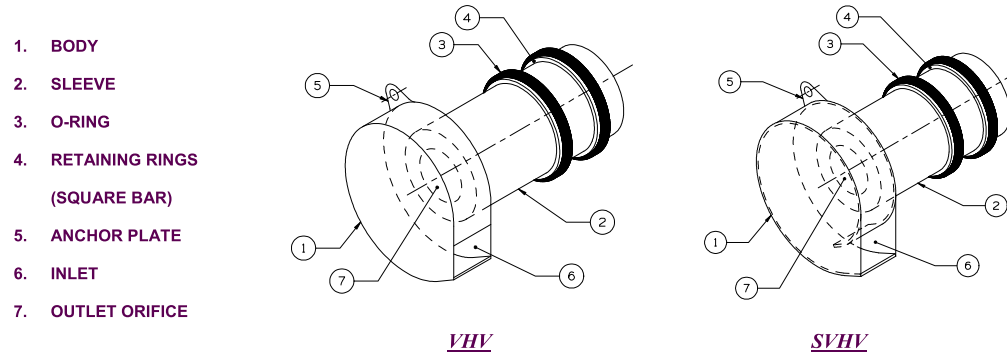

FIGURE 1: HYDROVEX® VHV-SVHV VERTICAL VORTEX FLOW REGULATORS

## ADVANTAGES

- The **HYDROVEX® VHV / SVHV** line of flow regulators are manufactured entirely of stainless steel, making them durable and corrosion resistant.
- Having no moving parts, they require minimal maintenance.
- The geometry of the **HYDROVEX® VHV / SVHV** flow regulators allows a control equal to an orifice plate, having a cross section area 4 to 6 times smaller. This decreases the chance of blockage of the regulator, due to sediments and debris found in stormwater flows. **Figure 2** illustrates the comparison between a regulator model 100 SVHV-2 and an equivalent orifice plate. One can see that for the same height of water, the regulator controls a flow approximately four times smaller than an equivalent orifice plate.
- Installation of the **HYDROVEX® VHV / SVHV** flow regulators is quick and straightforward and is performed after all civil works are completed.
- Installation requires no special tools or equipment and may be carried out by any contractor.
- Installation may be carried out in existing structures.

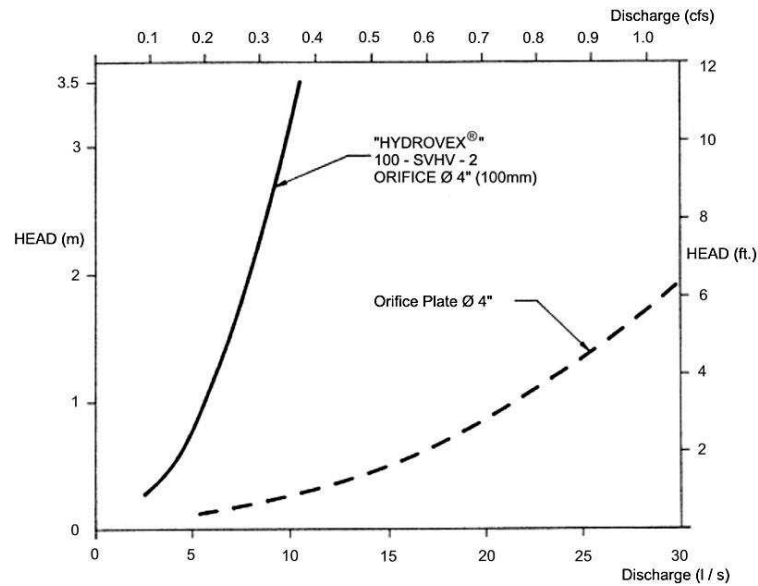

FIGURE 2: DISCHARGE CURVE SHOWING A HYDROVEX® FLOW REGULATOR VS AN ORIFICE PLATE

## SELECTION

Selection of a VHV or SVHV regulator can be easily made using the selection charts found at the back of this brochure (see Figure 3). These charts are a graphical representation of the maximum upstream water pressure (head) and the maximum discharge at the manhole outlet. The maximum design head is the difference between the maximum upstream water level and the invert of the outlet pipe. All selections should be verified by John Meunier Inc. personnel prior to fabrication.

### Example:

- ✓ Maximum design head      2m (6,56 ft.)
- ✓ Maximum discharge        6 L/s (0.2 cfs)
- ✓ Using Figure 3 - VHV      model required is a 75 VHV-1

## INSTALLATION REQUIREMENTS

All HYDROVEX® VHV / SVHV flow regulators can be installed in circular or square manholes. Figure 4 gives the various minimum dimensions required for a given regulator. *It is imperative to respect the minimum clearances shown to ensure easy installation and proper functioning of the regulator.*

## SPECIFICATIONS

In order to specify a **HYDROVEX**<sup>®</sup> regulator, the following parameters must be defined:

- The model number (ex: 75-VHV-1)
- The diameter and type of outlet pipe (ex: 6" diam. SDR 35)
- The desired discharge (ex: 6 l/s or 0.21 CFS)
- The upstream head (ex: 2 m or 6.56 ft.) \*
- The manhole diameter (ex: 36" diam.)
- The minimum clearance "H" (ex: 10 inches)
- The material type (ex: 304 s/s, 11 Ga. standard)

\* *Upstream head is defined as the difference in elevation between the maximum upstream water level and the invert of the outlet pipe where the **HYDROVEX**<sup>®</sup> flow regulator is to be installed.*

**PLEASE NOTE THAT WHEN REQUESTING A PROPOSAL, WE SIMPLY REQUIRE THAT YOU PROVIDE US WITH THE FOLLOWING:**

- *project design flow rate*
- *pressure head*
- *chamber's outlet pipe diameter and type*



*Typical VHV model in factory*

**OPTIONS**



*VHV-1-O (standard model with odour control inlet)*



*FV-SVHV (mounted on sliding plate)*



*FV-VHV-O (mounted on sliding plate with odour control inlet)*



*VHV with Gooseneck assembly in existing chamber without minimum release at the bottom*



*VHV with air vent for minimal slopes*



# VHV Vertical Vortex Flow Regulator

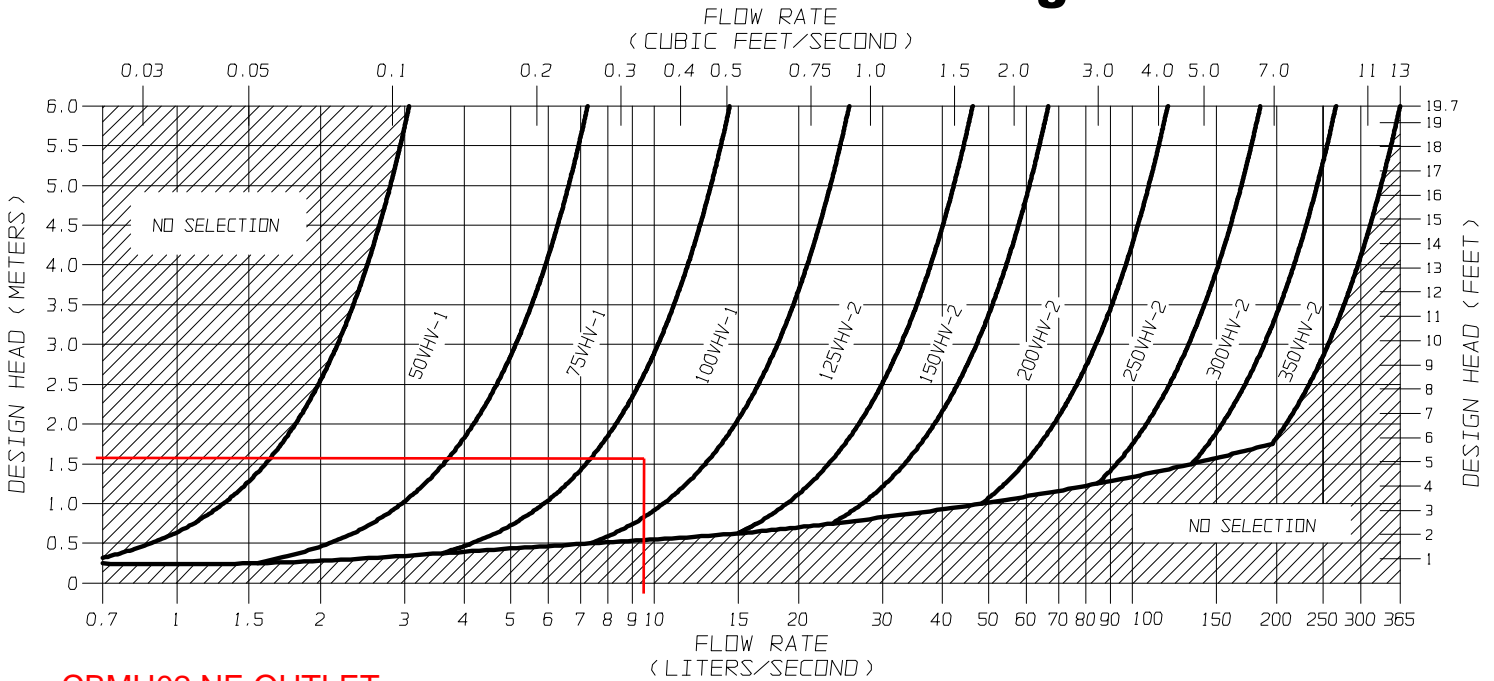

CBMH02 NE OUTLET  
HYDROVEX 100VHV-1  
DESIGN HEAD = 1.55m  
MAX FLOW RATE = 9.50 L/s

FIGURE 3 - VHV

**JOHN MEUNIER**



# SVHV Vertical Vortex Flow Regulator

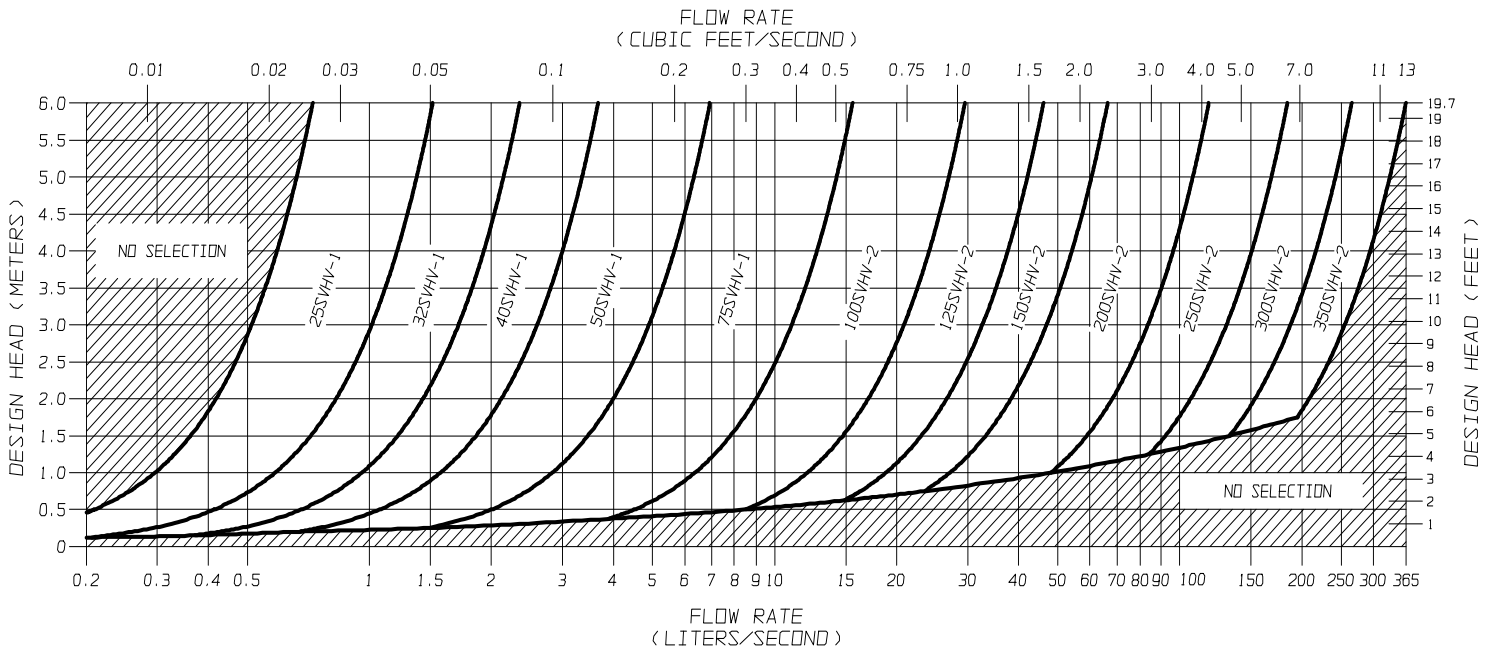
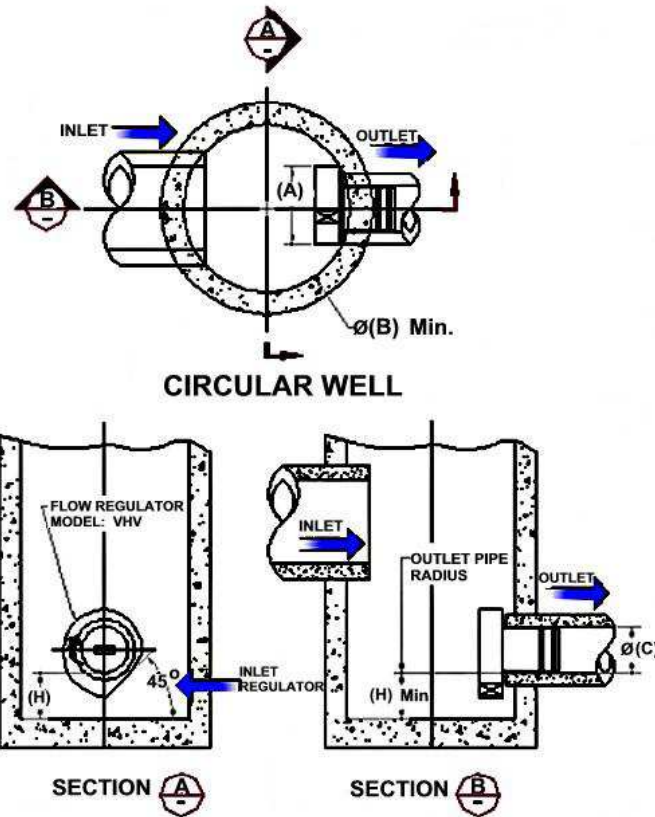

FIGURE 3 - SVHV

**JOHN MEUNIER**

**FLOW REGULATOR TYPICAL INSTALLATION IN CIRCULAR MANHOLE**  
**FIGURE 4 (MODEL VHV)**

Model Number	Regulator Diameter		Minimum Manhole Diameter		Minimum Outlet Pipe Diameter		Minimum Clearance	
	A (mm)	A (in.)	B (mm)	B (in.)	C (mm)	C (in.)	H (mm)	H (in.)
50VHV-1	150	6	600	24	150	6	150	6
75VHV-1	250	10	600	24	150	6	150	6
100VHV-1	325	13	900	36	150	6	200	8
125VHV-2	275	11	900	36	150	6	200	8
150VHV-2	350	14	900	36	150	6	225	9
200VHV-2	450	18	1200	48	200	8	300	12
250VHV-2	575	23	1200	48	250	10	350	14
300VHV-2	675	27	1600	64	250	10	400	16
350VHV-2	800	32	1800	72	300	12	500	20



**FLOW REGULATOR TYPICAL INSTALLATION IN CIRCULAR MANHOLE  
FIGURE 4 (MODEL SVHV)**

Model Number	Regulator Diameter		Minimum Manhole Diameter		Minimum Outlet Pipe Diameter		Minimum Clearance	
	A (mm)	A (in.)	B (mm)	B (in.)	C (mm)	C (in.)	H (mm)	H (in.)
25 SVHV-1	125	5	600	24	150	6	150	6
32 SVHV-1	150	6	600	24	150	6	150	6
40 SVHV-1	200	8	600	24	150	6	150	6
50 SVHV-1	250	10	600	24	150	6	150	6
75 SVHV-1	375	15	900	36	150	6	275	11
100 SVHV-2	275	11	900	36	150	6	250	10
125 SVHV-2	350	14	900	36	150	6	300	12
150 SVHV-2	425	17	1200	48	150	6	350	14
200 SVHV-2	575	23	1600	64	200	8	450	18
250 SVHV-2	700	28	1800	72	250	10	550	22
300 SVHV-2	850	34	2400	96	250	10	650	26
350 SVHV-2	1000	40	2400	96	250	10	700	28

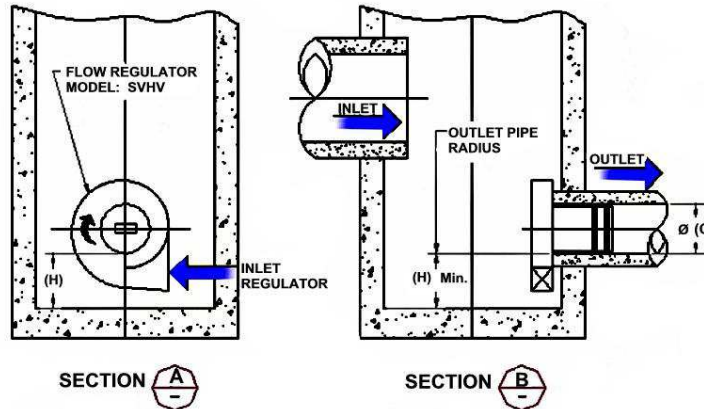
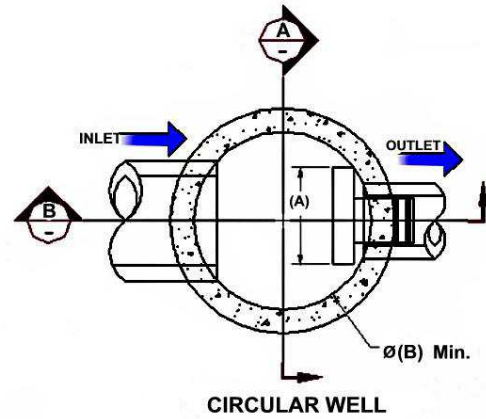

**FLOW REGULATOR TYPICAL INSTALLATION IN SQUARE MANHOLE**  
**FIGURE 4 (MODEL VHV)**

Model Number	Regulator Diameter		Minimum Chamber Width		Minimum Outlet Pipe Diameter		Minimum Clearance	
	A (mm)	A (in.)	B (mm)	B (in.)	C (mm)	C (in.)	H (mm)	H (in.)
50VHV-1	150	6	600	24	150	6	150	6
75VHV-1	250	10	600	24	150	6	150	6
100VHV-1	325	13	600	24	150	6	200	8
125VHV-2	275	11	600	24	150	6	200	8
150VHV-2	350	14	600	24	150	6	225	9
200VHV-2	450	18	900	36	200	8	300	12
250VHV-2	575	23	900	36	250	10	350	14
300VHV-2	675	27	1200	48	250	10	400	16
350VHV-2	800	32	1200	48	300	12	500	20

**NOTE:** *In the case of a square manhole, the outlet flow pipe must be centered on the wall to ensure enough clearance for the unit.*

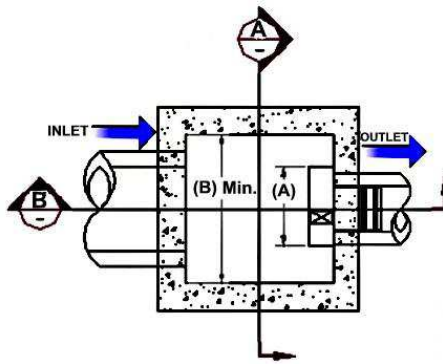

**SQUARE / RECTANGULAR WELL**

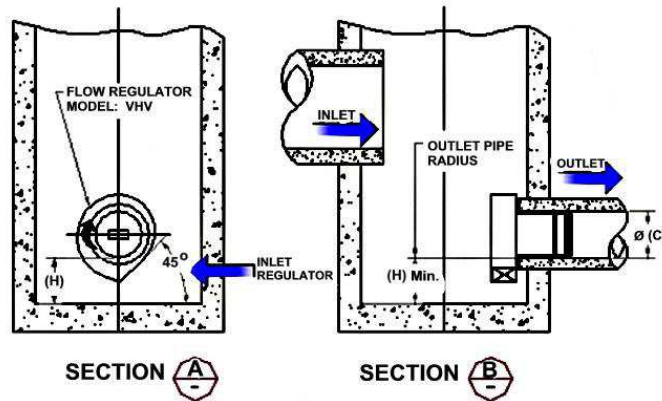

**FLOW REGULATOR TYPICAL INSTALLATION IN SQUARE MANHOLE  
FIGURE 4 (MODEL SVHV)**

Model Number	Regulator Diameter		Minimum Chamber Width		Minimum Outlet Pipe Diameter		Minimum Clearance	
	A (mm)	A (in.)	B (mm)	B (in.)	C (mm)	C (in.)	H (mm)	H (in.)
25 SVHV-1	125	5	600	24	150	6	150	6
32 SVHV-1	150	6	600	24	150	6	150	6
40 SVHV-1	200	8	600	24	150	6	150	6
50 SVHV-1	250	10	600	24	150	6	150	6
75 SVHV-1	375	15	600	24	150	6	275	11
100 SVHV-2	275	11	600	24	150	6	250	10
125 SVHV-2	350	14	600	24	150	6	300	12
150 SVHV-2	425	17	600	24 <td 150	6	350	14	
200 SVHV-2	575	23	900	36	200	8	450	18
250 SVHV-2	700	28	900	36	250	10	550	22
300 SVHV-2	850	34	1200	48	250	10	650	26
350 SVHV-2	1000	40	1200	48	250	10	700	28

**NOTE:** *In the case of a square manhole, the outlet flow pipe must be centered on the wall to ensure enough clearance for the unit.*

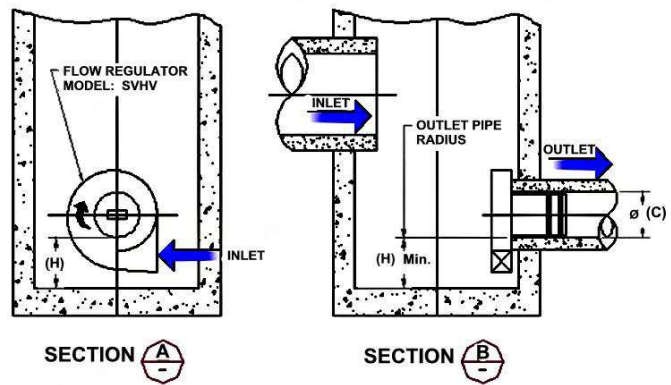
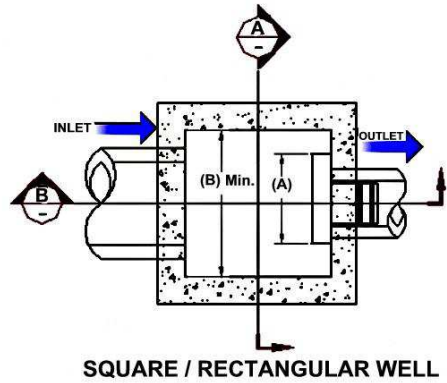

## INSTALLATION

The installation of a **HYDROVEX**<sup>®</sup> regulator may be undertaken once the manhole and piping is in place. Installation consists of simply fitting the regulator into the outlet pipe of the manhole. **John Meunier Inc.** recommends the use of a lubricant on the outlet pipe, in order to facilitate the insertion and orientation of the flow controller.

## MAINTENANCE

**HYDROVEX**<sup>®</sup> regulators are manufactured in such a way as to be maintenance free; however, a periodic inspection (every 3-6 months) is suggested in order to ensure that neither the inlet nor the outlet has become blocked with debris. The manhole should undergo periodically, particularly after major storms, inspection and cleaning as established by the municipality

## GUARANTY

The **HYDROVEX**<sup>®</sup> line of **VHV / SVHV** regulators are guaranteed against both design and manufacturing defects for a period of 5 years. Should a unit be defective, **John Meunier Inc.** is solely responsible for either modification or replacement of the unit.

### **John Meunier Inc.**

ISO 9001 : 2008

#### **Head Office**

4105 Sartelon  
Saint-Laurent (Quebec) Canada H4S 2B3  
Tel.: 514-334-7230 [www.johnmeunier.com](http://www.johnmeunier.com)  
Fax: 514-334-5070 [cs@johnmeunier.com](mailto:cs@johnmeunier.com)

#### **Ontario Office**

2000 Argentia Road, Plaza 4, Unit 430  
Mississauga (Ontario) Canada L5N 1W1  
Tel.: 905-286-4846 [www.johnmeunier.com](http://www.johnmeunier.com)  
Fax: 905-286-0488 [ontario@johnmeunier.com](mailto:ontario@johnmeunier.com)

#### **USA Office**

2209 Menlo Avenue  
Glenside, PA USA 19038  
Tel.: 412-417-6614 [www.johnmeunier.com](http://www.johnmeunier.com)  
Fax: 215-885-4741 [asteel@johnmeunier.com](mailto:asteel@johnmeunier.com)



Revised: 2011-05-03

# **APPENDIX E**

## **Civil Engineering Drawings**



**EROSION AND SEDIMENT CONTROL MEASURES:**

"CONTRACTOR IS RESPONSIBLE FOR ALL INSTALLATION, MONITORING, REPAIR AND REMOVAL OF ALL EROSION AND SEDIMENT CONTROL FEATURES"

**1. PRIOR TO START OF CONSTRUCTION:**

- PRIOR TO THE REMOVAL OF ANY VEGETATIVE COVER, MOVING OF SOIL, AND CONSTRUCTION:
- INSTALL SILT FENCE IMMEDIATELY DOWNSTREAM FROM AREAS TO BE DISTURBED (SEE PLAN FOR LOCATION).
- INSPECT MEASURES IMMEDIATELY AFTER INSTALLATION.

**2. DURING CONSTRUCTION:**

- WORK TO BE DONE IN THE VICINITY OF MAJOR WATERWAYS TO BE CARRIED OUT FROM JULY TO SEPTEMBER ONLY.
- MINIMIZE THE EXTENT OF DISTURBED AREAS AND THE DURATION OF EXPOSURE.
- PROTECT TEMPORARILY DISTURBED AREAS FROM RUNOFF.
- PROVIDE TEMPORARY COVER SUCH AS SEEDING OR MULCHING IF DISTURBED AREA WILL NOT BE REHABILITATED WITHIN 30 DAYS.
- INSPECT SILT FENCES AND CHECK DAMS WEEKLY, AND AFTER EVERY MAJOR STORM EVENT. CLEAN AND REPAIR WHEN NECESSARY.
- PLAN TO BE REVIEWED AND REVISED AS REQUIRED DURING CONSTRUCTION.
- EROSION CONTROL FENCING TO BE ALSO INSTALLED AROUND THE BASE OF ALL STOCKPILES.
- DO NOT LOCATE TOPSOIL PILES AND EXCAVATION MATERIAL CLOSER THAN 2.5m FROM ANY PAVED SURFACE, OR ONE WHICH IS TO BE PAVED BEFORE THE PILE IS REMOVED. ALL TOPSOIL PILES ARE TO BE SEEDED IF THEY ARE TO REMAIN ON SITE LONG ENOUGH FOR SEEDS TO GROW (LONGER THAN 30 DAYS).
- CONTROL WIND-BLOWN DUST OFF SITE TO ACCEPTABLE LEVELS BY SEEDING TOPSOIL PILES AND OTHER AREAS TEMPORARILY (PROVIDE WATERING AS REQUIRED).
- ALL EROSION CONTROL STRUCTURES TO REMAIN IN PLACE UNTIL ALL DISTURBED GROUND SURFACES HAVE BEEN STABILIZED EITHER BY PAVING OR RESTORATION OF VEGETATIVE GROUND COVER.
- ALL ALTERNATE METHODS OF EROSION PROTECTION SHALL BE PERMITTED UNLESS APPROVED BY THIS CONSULTING ENGINEER AND THE CITY DEPARTMENT OF PUBLIC WORKS.
- CONTRACTOR RESPONSIBLE FOR CITY ROADWAY TO BE CLEANED OF ALL SEDIMENT FROM VEHICULAR TRACKING ETC. AT THE END OF EACH WORK DAY.
- PROVIDE GRAVEL ENTRANCE WHEREVER EQUIPMENT LEAVES THE SITE TO PREVENT MUD TRACKING ONTO PAVED SURFACES. GRAVEL BED SHALL BE A MINIMUM OF 15m LONG, 4m WIDE AND 0.3m DEEP AND SHALL CONSIST OF COARSE (50mm CRUSHED RUMBLE) MATERIAL. MAINTAIN GRAVEL ENTRANCE IN CLEAN CONDITION.
- DURING WET CONDITIONS, TIRES OF ALL VEHICLES/EQUIPMENT LEAVING THE SITE ARE TO BE SCRAPED.
- ANY MUD/MATERIAL TRACKED ONTO THE ROAD SHALL BE REMOVED IMMEDIATELY BY HAND OR RUBBER TIRE LOADER.
- TAKE ALL NECESSARY STEPS TO PREVENT BUILDING MATERIAL, CONSTRUCTION DEBRIS OR WASTE BEING SPILLED OR TRACKED ONTO ADJUTING PROPERTIES OR PUBLIC STREETS DURING CONSTRUCTION AND PROCEED IMMEDIATELY TO EFFECTIVELY CLEAN UP ANY AREAS AFFECTED.

**3. AFTER CONSTRUCTION:**

- PROVIDE PERMANENT COVER CONSISTING OF TOPSOIL AND SEED TO DISTURBED AREAS.
- REMOVE STRAW BALE FLOW CHECK DAMS AND SILT FENCES AFTER DISTURBED AREAS HAVE BEEN REHABILITATED AND STABILIZED.

**GENERAL:**

THE CONTRACTOR SHALL IMPLEMENT BEST MANAGEMENT PRACTICES, TO PROVIDE FOR PROTECTION OF THE AREA DRAINAGE SYSTEM AND THE RECEIVING WATERCOURSE, DURING CONSTRUCTION ACTIVITIES. THE CONTRACTOR ACKNOWLEDGES THAT FAILURE TO IMPLEMENT APPROPRIATE EROSION AND SEDIMENT CONTROL MEASURES MAY BE SUBJECT TO PENALTIES IMPOSED BY ANY APPLICABLE REGULATORY AGENCY.

THE CONTRACTOR ACKNOWLEDGES THAT SURFACE EROSION AND SEDIMENT RUNOFF RESULTING FROM THEIR CONSTRUCTION OPERATIONS HAS POTENTIAL TO CAUSE A DETRIMENTAL IMPACT TO ANY DOWNSTREAM WATERCOURSE, AND THAT ALL CONSTRUCTION OPERATIONS THAT MAY IMPACT UPON WATER QUALITY SHALL BE CARRIED OUT IN MANNER THAT STRICTLY MEETS THE REQUIREMENT OF ALL APPLICABLE LEGISLATION AND REGULATIONS.

AS SUCH, THE CONTRACTOR SHALL BE RESPONSIBLE FOR CARRYING OUT THEIR OPERATIONS, AND SUPPLYING AND INSTALLING ANY APPROPRIATE CONTROL MEASURES, SO AS TO PREVENT SEDIMENT LADEN RUNOFF ENTERING ANY WATERCOURSE WITHIN OR DOWNSTREAM OF THE WORKING AREA.

THE CONTRACTOR ACKNOWLEDGES THAT NO ONE MEASURE IS LIKELY TO BE 100% EFFECTIVE FOR EROSION PROTECTION AND CONTROLLING SEDIMENT RUNOFF AND DISCHARGES FROM THE SITE. THEREFORE, WHERE NECESSARY, THE CONTRACTOR SHALL IMPLEMENT ADDITIONAL MEASURES ARRANGED IN SUCH MANNER AS TO MITIGATE SEDIMENT RELEASE FROM THE CONSTRUCTION OPERATIONS AND ACHIEVE SPECIFIC MAXIMUM PERMITTED CRITERIA WHERE APPLICABLE. SUGGESTED ON-SITE MEASURES MAY INCLUDE, BUT SHALL NOT BE LIMITED TO, THE FOLLOWING METHODS: SEDIMENT PONDS, FILTER BAGS, PUMP FILTERS, SETTLING TANKS, SILT FENCE, STRAW BALES, FILTER CLOTHS, CHECK DAMS AND/OR OTHER RECOGNIZED TECHNOLOGIES AND METHOD AVAILABLE AT THE TIME OF CONSTRUCTION. SPECIFIC MEASURES SHALL BE INSTALLED IN ACCORDANCE WITH REQUIREMENTS OF OPS 577 WHERE APPROPRIATE, OR IN ACCORDANCE WITH MANUFACTURER'S RECOMMENDATIONS.

WHERE, IN THE OPINION OF THE CONTRACT ADMINISTRATOR OR REGULATORY AGENCY, THE INSTALLED CONTROL MEASURES FAIL TO PERFORM ADEQUATELY, THE CONTRACTOR SHALL SUPPLY AND INSTALL ADDITIONAL OR ALTERNATIVE MEASURES AS DIRECTED BY THE CONTRACT ADMINISTRATOR OR REGULATORY AGENCY, AS SUCH, THE CONTRACTOR SHALL HAVE ADDITIONAL CONTROL MATERIALS ON SITE AT ALL TIME WHICH ARE EASILY ACCESSIBLE AND MAY BE IMPLEMENTED BY THE CONTRACT ADMINISTRATOR AT THE MOMENT'S NOTICE.

PRIOR TO COMMENCING WORK, THE CONTRACTOR SHALL SUBMIT TO THE CONTRACT ADMINISTRATOR SIX COPIES OF A DETAILED EROSION AND SEDIMENT CONTROL PLAN (ESCP). THE ESCP WILL CONSIST OF WRITTEN DESCRIPTION AND DETAILED DRAWINGS INDICATING THE ON-SITE ACTIVITIES AND MEASURES TO BE USED TO CONTROL EROSION AND SEDIMENT MOVEMENT FOR EACH STEP OF THE WORK.

**CONTRACTOR'S RESPONSIBILITIES:**

THE CONTRACTOR SHALL ENSURE THAT ALL WORKERS, INCLUDING SUB-CONTRACTOR, IN THE WORKING AREA ARE AWARE OF THE IMPORTANCE OF THE EROSION AND SEDIMENT CONTROL MEASURES AND INFORMED OF THE CONSEQUENCES OF THE FAILURE TO COMPLY WITH THE REQUIREMENTS OF ALL REGULATORY AGENCIES.

THE CONTRACTOR SHALL PERIODICALLY, AND WHEN REQUESTED BY THE CONTRACT ADMINISTRATOR, CLEAN OUT ACCUMULATED SEDIMENTS AS REQUIRED AT THE SEDIMENT CONTROL DEVICES, INCLUDING THOSE DEPOSITS THAT MAY ORIGINATE FROM OUTSIDE THE CONSTRUCTION AREA. ACCUMULATED SEDIMENT SHALL BE REMOVED IN SUCH A MANNER THAT PREVENTS THE DEPOSITION OF THIS MATERIAL INTO THE SEWER WATERCOURSE AND AVOIDS DAMAGE TO CONTROL MEASURES. THE SEDIMENT SHALL BE REMOVED FROM THE SITE AT THE CONTRACTOR'S EXPENSE AND MANAGED IN COMPLIANCE WITH REQUIREMENTS FOR EXCESS EARTH MATERIAL, AS SPECIFIED ELSEWHERE IN THE CONTRACT.

THE CONTRACTOR SHALL IMMEDIATELY REPORT TO THE CONTRACT ADMINISTRATOR ANY ACCIDENTAL DISCHARGES OF SEDIMENT MATERIAL INTO THE WATERCOURSE. FAILURE TO REPORT WILL BE CONSTITUTE A BREACH OF THIS SPECIFICATION AND THE CONTRACTOR MAY ALSO BE SUBJECT TO THE PENALTIES IMPOSED BY THE APPLICABLE REGULATORY AGENCY. APPROPRIATE RESPONSE MEASURES, INCLUDING ANY REPAIRS TO EXISTING CONTROL MEASURES OR THE IMPLEMENTATION OF ADDITIONAL CONTROL MEASURES, SHALL BE CARRIED OUT BY THE CONTRACTOR WITHOUT DELAY.

THE SEDIMENT CONTROL MEASURES SHALL ONLY BE REMOVED WHEN, IN THE OPINION OF THE CONTRACT ADMINISTRATOR, THE MEASURE OR MEASURES, IS NO LONGER REQUIRED. NO CONTROL MEASURE MAY BE PERMANENTLY REMOVED WITHOUT PRIOR AUTHORIZATION FROM THE CONTRACT ADMINISTRATOR. ALL SEDIMENT AND EROSION CONTROL MEASURES SHALL BE REMOVED IN A MANNER THAT AVOIDS THE ENTRY OF ANY EQUIPMENT, OTHER THAN HAND-HELD EQUIPMENT, INTO ANY WATERCOURSE, AND PREVENTS THE RELEASE OF ANY SEDIMENT OR DEBRIS INTO ANY SEWER OR WATERCOURSE WITHIN OR DOWNSTREAM OF THE WORKING AREA. ALL ACCUMULATED SEDIMENT SHALL BE REMOVED FROM THE WORKING AREA AT THE CONTRACTOR'S EXPENSE AND MANAGED IN COMPLIANCE WITH THE REQUIREMENTS FOR EXCESS EARTH MATERIAL.

WHERE, IN THE OPINION OF EITHER THE CONTRACT ADMINISTRATOR OR A REGULATORY AGENCY, ANY OF THE TERMS SPECIFIED HEREIN HAVE NOT BEEN COMPLIED WITH OR PERFORMED IN A SUITABLE MANNER, OR AT ALL, THE CONTRACT ADMINISTRATOR OR A REGULATORY AGENCY HAS THE RIGHT TO IMMEDIATELY WITHDRAW ITS PERMISSION TO CONTINUE THE WORK BUT MAY RENEW ITS PERMISSION UPON BEING SATISFIED THAT THE DEFAULTS OR DEFICIENCIES IN THE PERFORMANCE OF THIS SPECIFICATION BY THE CONTRACTOR HAVE BEEN REMEDIATED.

**SPILL CONTROL NOTES:**

1. ALL CONSTRUCTION EQUIPMENT SHALL BE RE-FUELED, MAINTAINED, AND STORED NO LESS THAN 30 METRES FROM WATERCOURSE, STREAMS, CREEKS, WOODLOTS, AND ANY ENVIRONMENTALLY SENSITIVE AREAS, OR AS OTHERWISE SPECIFIED.
2. THE CONTRACTOR MUST IMPLEMENT ALL NECESSARY MEASURES IN ORDER TO PREVENT LEAKS, DISCHARGES OR SPILLS OF POLLUTANTS, DELETERIOUS MATERIALS, OR OTHER SUCH MATERIALS OR SUBSTANCES WHICH WOULD OR COULD CAUSE AN ADVERSE IMPACT TO THE NATURAL ENVIRONMENT.
3. IN THE EVENT OF A LEAK, DISCHARGE OR SPILL OF POLLUTANT, DELETERIOUS MATERIAL OR OTHER SUCH MATERIAL OR SUBSTANCE WHICH WOULD OR COULD CAUSE AN ADVERSE IMPACT TO THE NATURAL ENVIRONMENT, THE CONTRACTOR SHALL:
  - 3.1. IMMEDIATELY NOTIFY APPROPRIATE FEDERAL, PROVINCIAL, AND LOCAL GOVERNMENT MINISTRIES, DEPARTMENTS, AGENCIES, AND AUTHORITIES OF THE INCIDENT IN ACCORDANCE WITH ALL CURRENT LAWS, LEGISLATION, ACTS, BY-LAWS, PERMITS, APPROVALS, ETC.
  - 3.2. TAKE IMMEDIATE MEASURES TO CONTAIN THE MATERIAL OR SUBSTANCE, AND TO TAKE SUCH MEASURES TO MITIGATE AGAINST ADVERSE IMPACTS TO THE NATURAL ENVIRONMENT.
  - 3.3. RESTORE THE AFFECTED AREA TO THE ORIGINAL CONDITION OR BETTER TO THE SATISFACTION OF THE AUTHORITIES HAVING JURISDICTION.

**MUD MAT NOTES:**

1. THE GRANULAR MATERIAL WILL REQUIRE PERIODIC REPLACEMENT AS IT BECOMES CONTAMINATED BY VEHICLE TRAFFIC.
2. SEDIMENT SHALL BE CLEANED FROM PUBLIC ROADS AT THE END OF EACH DAY.
3. SEDIMENT SHALL BE REMOVED FROM PUBLIC ROADS BY SHOVELING OR SWEEPING AND DISPOSED OR PROPERLY IN A CONTROLLED SEDIMENT DISPOSAL AREA.

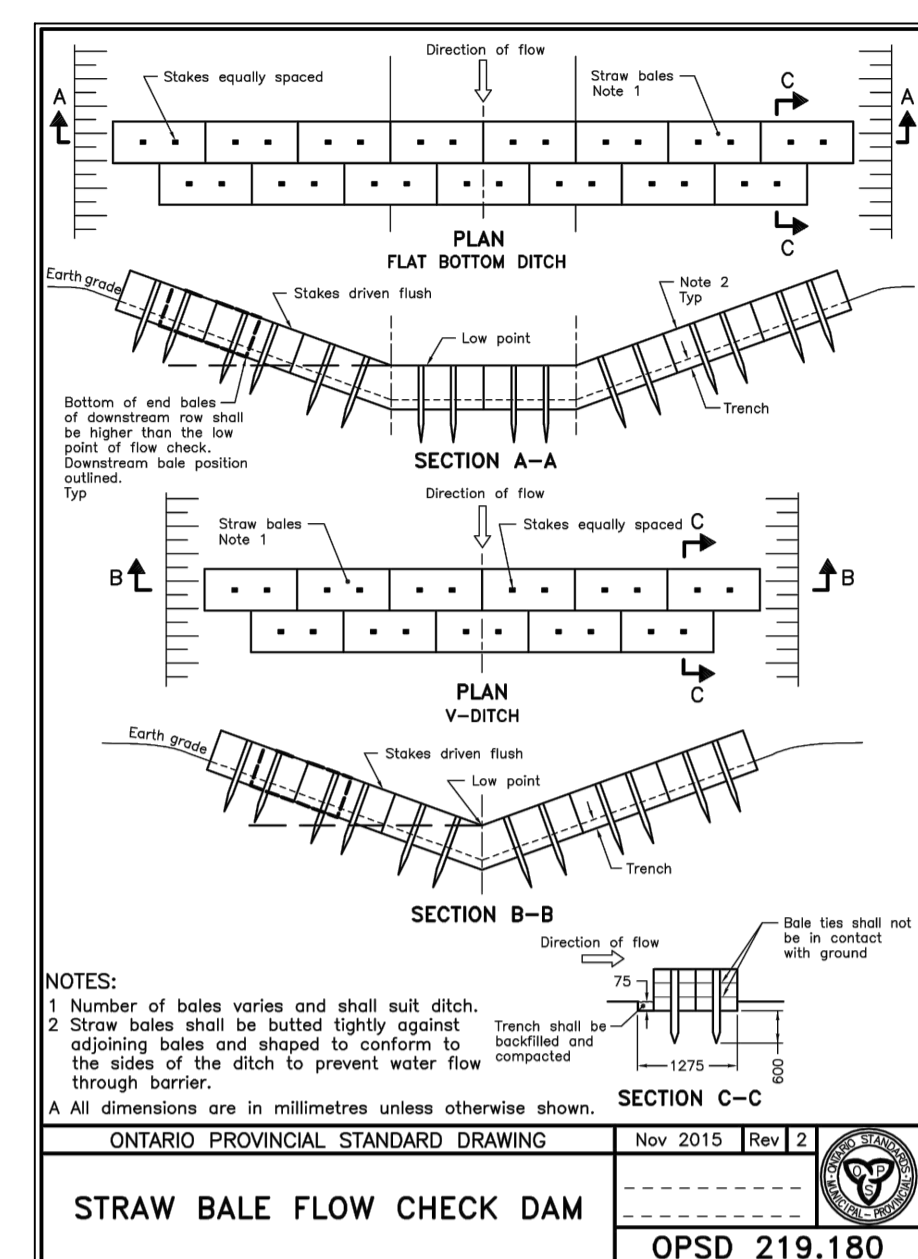
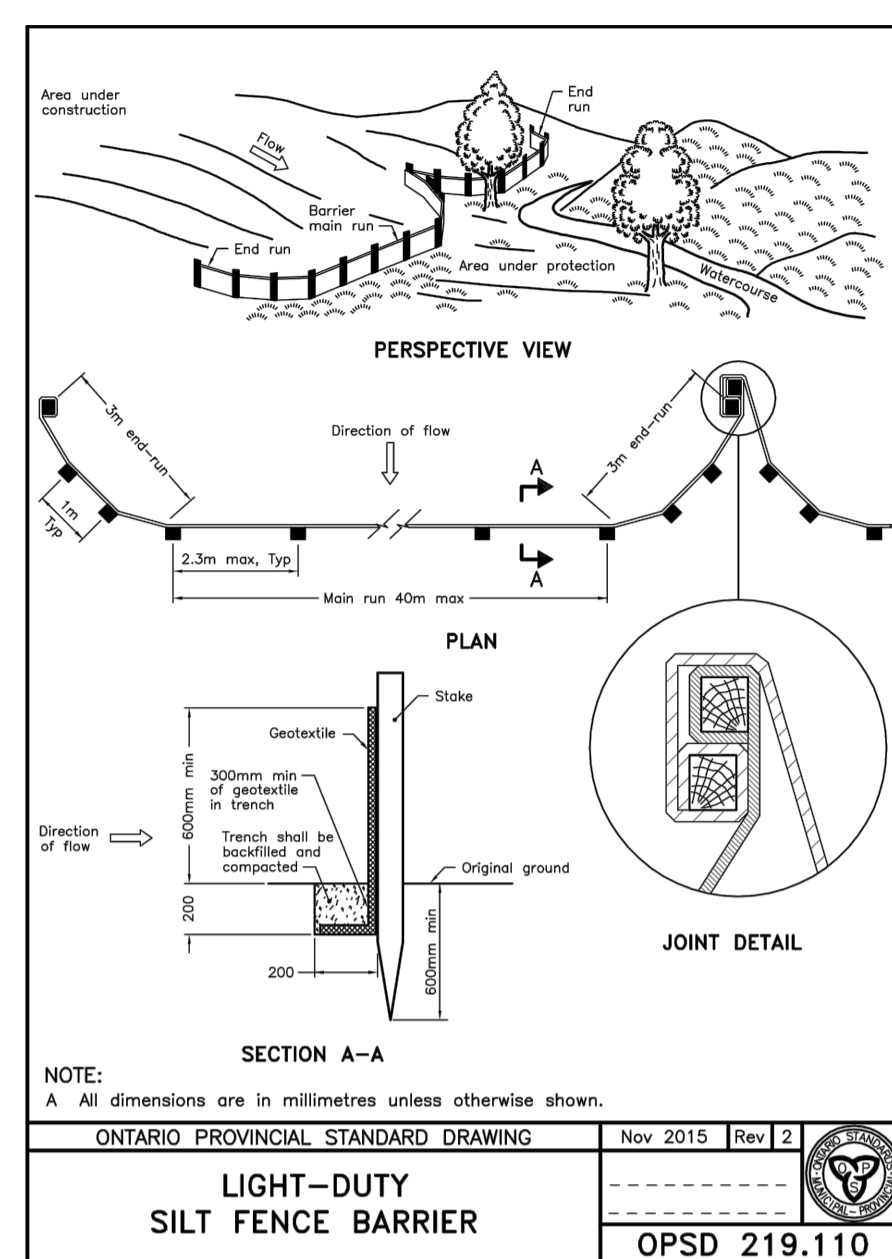
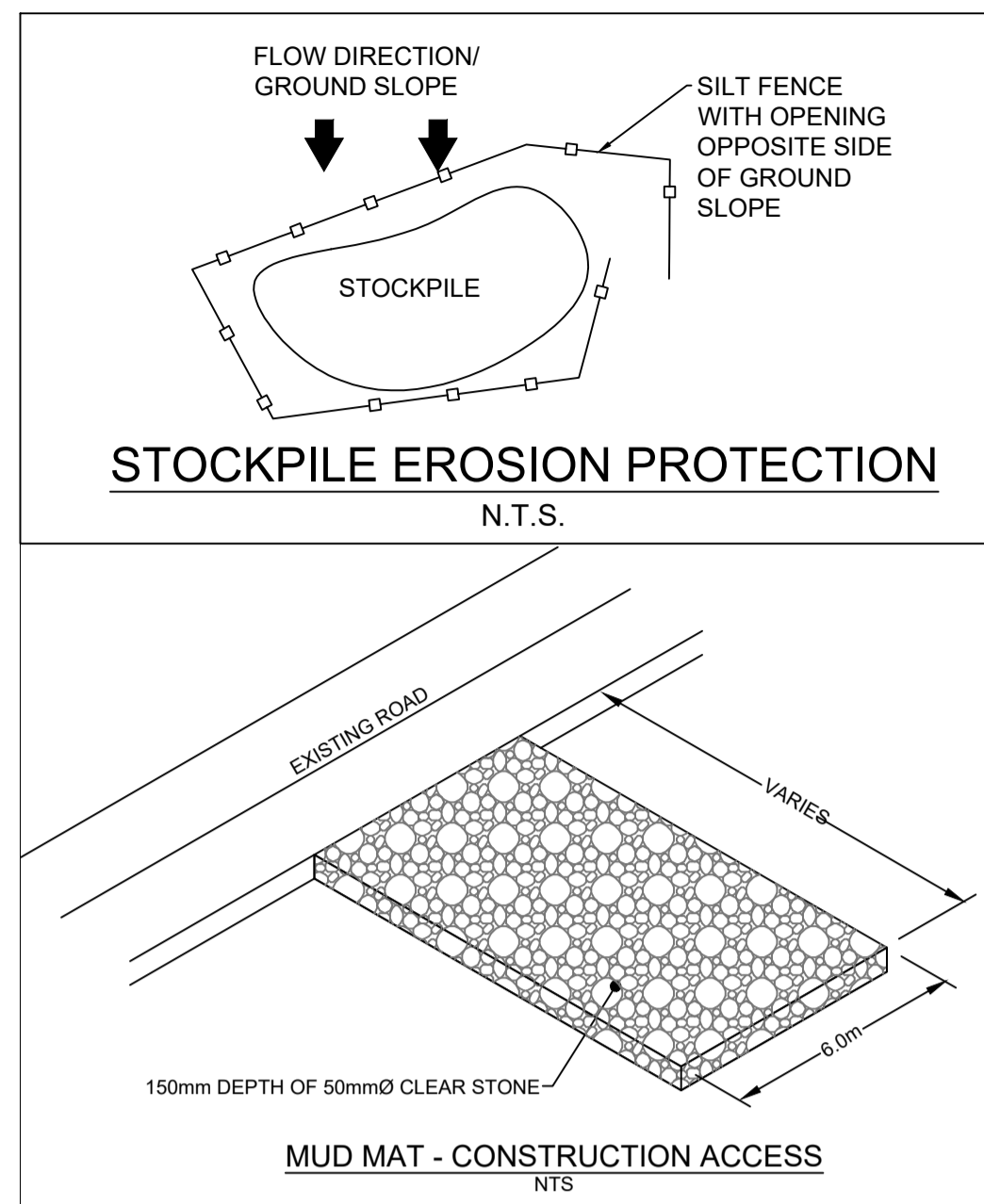

**LEGEND:**

- EXISTING PROPERTY LINE TO REMAIN
- PROPOSED CURB
- PROPOSED DEPRESSED CURB
- PROPOSED TERRACING (3:1 MIN.)
- PROPOSED SILT FENCE AS PER OPSD 219.110
- PROPOSED DOOR ENTRANCE/EXIT
- PROPOSED GRASS AREA (100mm TOP SOIL & SOD)
- PROPOSED GRASS AREA (100mm TOP SOIL & SEED)
- PROPOSED CONCRETE FEATURES/SLAB
- PROPOSED HEAVY DUTY ASPHALT
- PROPOSED LIGHT DUTY ASPHALT
- PROPOSED GRAVEL SHOULDER
- PROPOSED RIP RAP
- PROPOSED ELEVATION
- PROPOSED HIGH POINT ELEVATION
- PROPOSED BOTTOM OF CURB / ASPHALT ELEVATION
- PROPOSED TOP OF CURB ELEVATION
- PROPOSED EXPOSED BOTTOM OF RETAINING WALL
- PROPOSED TOP OF RETAINING WALL
- MATCH INTO EXISTING ELEVATION
- EXISTING ELEVATION
- PROPOSED OVERLAND MAJOR FLOW ROUTE
- EXISTING OVERLAND DRAINAGE PATTERN
- PROPOSED STORM SEWER
- PROPOSED SANITARY SEWER
- PROPOSED WATERMAIN
- EXISTING STORM SEWER
- EXISTING SANITARY SEWER
- EXISTING WATERMAIN
- EXISTING CATCHBASIN-MANHOLE/MANHOLE
- EXISTING CATCHBASIN
- PROPOSED CATCHBASIN-MANHOLE/MANHOLE
- PROPOSED CATCHBASIN
- PROPOSED CURB STOP
- PROPOSED 100 YEAR HIGH WATER LEVEL
- STORM WATERSHED EXTENT
- WATERSHED NAME
- RUNOFF COEFFICIENT
- AREA IN HECTARES

**GENERAL INTERPRETATION OF DRAWINGS**

GENERAL CONDITIONS OF THE CONTRACT FOR CONSTRUCTION ARE PART OF THE CONTRACT DOCUMENTS AND DESCRIBE USE AND INTENT OF THE DRAWINGS. THE CONTRACT DOCUMENTS INCLUDE NOT ONLY THE DRAWINGS, BUT ALSO THE OWNER CONTRACTOR AGREEMENTS, CONDITIONS OF THE CONTRACT, THE SPECIFICATIONS, ADDENDA AND MODIFICATIONS ISSUED AFTER EXECUTION OF THE CONTRACT. THESE CONTRACT DOCUMENTS ARE COMPLEMENTARY, AND WHAT IS REQUIRED BY ANY ONE SHALL BE BINDING AS REQUIRED BY ALL WORK NOT COMPLETELY DELINEATED HEREON SHALL BE CONSTRUCTED OF THE SAME MATERIALS AND DETAILED SIMILARLY AS WORK SHOWN MORE COMPLETELY ELSEWHERE IN THE CONTRACT DOCUMENTS.

BY USE OF THE DRAWINGS FOR CONSTRUCTION OF THE PROJECT, THE OWNER CONFIRMS THAT HE HAS REVIEWED AND APPROVED THE DRAWINGS. THE CONTRACTOR CONFIRMS THAT HE HAS REVIEWED AND APPROVED THE SITE, FAMILIARIZED HIMSELF WITH THE LOCAL CONDITIONS, VERIFIED FIELD DIMENSIONS AND CORRELATED THEIR OBSERVATIONS WITH THE REQUIREMENTS OF THE CONTRACT DOCUMENTS.

AS INSTRUMENTS OF SERVICE, ALL DRAWINGS, SPECIFICATIONS, CAD FILES OR OTHER ELECTRONIC MEDIA AND COPIES THEREOF FURNISHED BY THE ENGINEER ARE THEIR PROPERTY. THEY ARE TO BE USED ONLY FOR THIS PROJECT AND ARE NOT TO BE USED ON ANY OTHER PROJECT, INCLUDING REPEATS OF THE PROJECT. CHANGES TO THE DRAWINGS MAY ONLY BE MADE BY THE ENGINEER.

UNLESS THE REVISION TITLE IS "ISSUED FOR CONSTRUCTION", THESE DRAWINGS SHALL BE CONSIDERED PRELIMINARY AND SHALL NOT BE USED AS A CONSTRUCTION DOCUMENT.

THESE DRAWINGS ILLUSTRATE THE WORK TO BE DONE. THE ENGINEER IS NOT RESPONSIBLE FOR THE MEANS, METHODS, TECHNIQUES, SEQUENCES, AND PROCEDURES USED TO DO THE WORK, OR THE SAFETY ASPECTS OF CONSTRUCTION, AND NOTHING ON THESE DRAWINGS EXPRESSED OR IMPLIED CHANGES THIS CONDITION. CONTRACTOR SHALL DETERMINE ALL CONDITIONS AT THE SITE AND SHALL BE RESPONSIBLE FOR KNOWING HOW THEY AFFECT THE WORK. SUBMITTAL OF A BID TO PERFORM THIS WORK IS ACKNOWLEDGEMENT OF THE RESPONSIBILITIES AND THAT THEY HAVE BEEN FULLY CONSIDERED IN PLANNING OF THE WORK, AND THE BID PRICE. NO CLAIMS FOR EXTRA CHARGES DUE TO THESE CONDITIONS WILL BE FORTHCOMING.

**UNAUTHORIZED CHANGES:**

IN THE EVENT THE CLIENT, THE CLIENT'S CONTRACTORS OR SUBCONTRACTORS, OR ANYONE FOR WHOM THE CLIENT IS LEGALLY LIABLE MAKES OR PERMITS TO BE MADE ANY CHANGES TO ANY REPORTS, PLANS, SPECIFICATIONS OR OTHER CONSTRUCTION DOCUMENTS PREPARED BY OR ASSOCIATED LTD. (LTD) WITHOUT OBTAINING LRL'S PRIOR WRITTEN CONSENT, THE CLIENT SHALL ASSUME FULL RESPONSIBILITY FOR THE RESULTS OF SUCH CHANGES. THEREFORE THE CLIENT AGREES TO WAIVE ANY CLAIM AGAINST LRL AND TO RELEASE LRL FROM ANY LIABILITY ARISING DIRECTLY OR INDIRECTLY FROM SUCH UNAUTHORIZED CHANGES.

IN ADDITION, THE CLIENT AGREES TO THE FULLEST EXTENT PERMITTED BY LAW, TO INDEMNIFY AND HOLD HARMLESS LRL FROM ANY DAMAGES, LIABILITIES OR COSTS, INCLUDING REASONABLE ATTORNEY'S FEES AND COST OF DEFENSE, ARISING FROM SUCH CHANGES.

IN ADDITION, THE CLIENT AGREES TO INCLUDE IN ANY CONTRACTS FOR CONSTRUCTION APPROPRIATE LANGUAGE THAT PROHIBITS THE CONTRACTOR OR ANY SUBCONTRACTORS OF ANY TIER FROM MAKING ANY CHANGES OR MODIFICATIONS TO LRL'S CONSTRUCTION DOCUMENTS WITHOUT THE PRIOR WRITTEN APPROVAL OF LRL, AND THAT REQUIRES THE CONTRACTOR TO INDEMNIFY BOTH LRL AND THE CLIENT FROM ANY LIABILITY OR COST ARISING FROM SUCH CHANGES MADE WITHOUT SUCH PROPER AUTHORIZATION.

**GENERAL NOTES:**

EXISTING SERVICES AND UTILITIES SHOWN ON THESE DRAWINGS ARE TAKEN FROM THE BEST AVAILABLE RECORDS, BUT MAY NOT BE COMPLETE OR DATE. CONTRACTOR SHALL VERIFY IN FIELD FOR LOCATION AND ELEVATION OF PIPES AND CHECK WITH THE UTILITY COMPANIES BEFORE DIGGING OR CONSTRUCTION WORK.

CONTRACTOR IS ADVISED TO COLLECT INFORMATION ON SOIL CONDITIONS BEFORE START OF CONSTRUCTION.

THE ENGINEER WAIVES ANY AND ALL RESPONSIBILITY AND LIABILITY FOR PROBLEMS WHICH ARISE FROM FAILURE TO FOLLOW THESE PLANS, SPECIFICATIONS AND THE DESIGN INTENT THEY CONVEY, OR FOR PROBLEMS WHICH ARISE FROM OTHERS' FAILURE TO OBTAIN AND/OR FOLLOW THE ENGINEER'S GUIDANCE WITH RESPECT TO ANY ERRORS, OMISSIONS, INCONSISTENCIES AMBIGUITIES OR CONFLICTS WHICH ARE ALLEGED.

CONTRACTOR TO VERIFY ALL DIMENSIONS AND NOTIFY THE ENGINEER OF ANY DISCREPANCIES BEFORE WORK COMMENCES. DO NOT SCALE DRAWINGS.

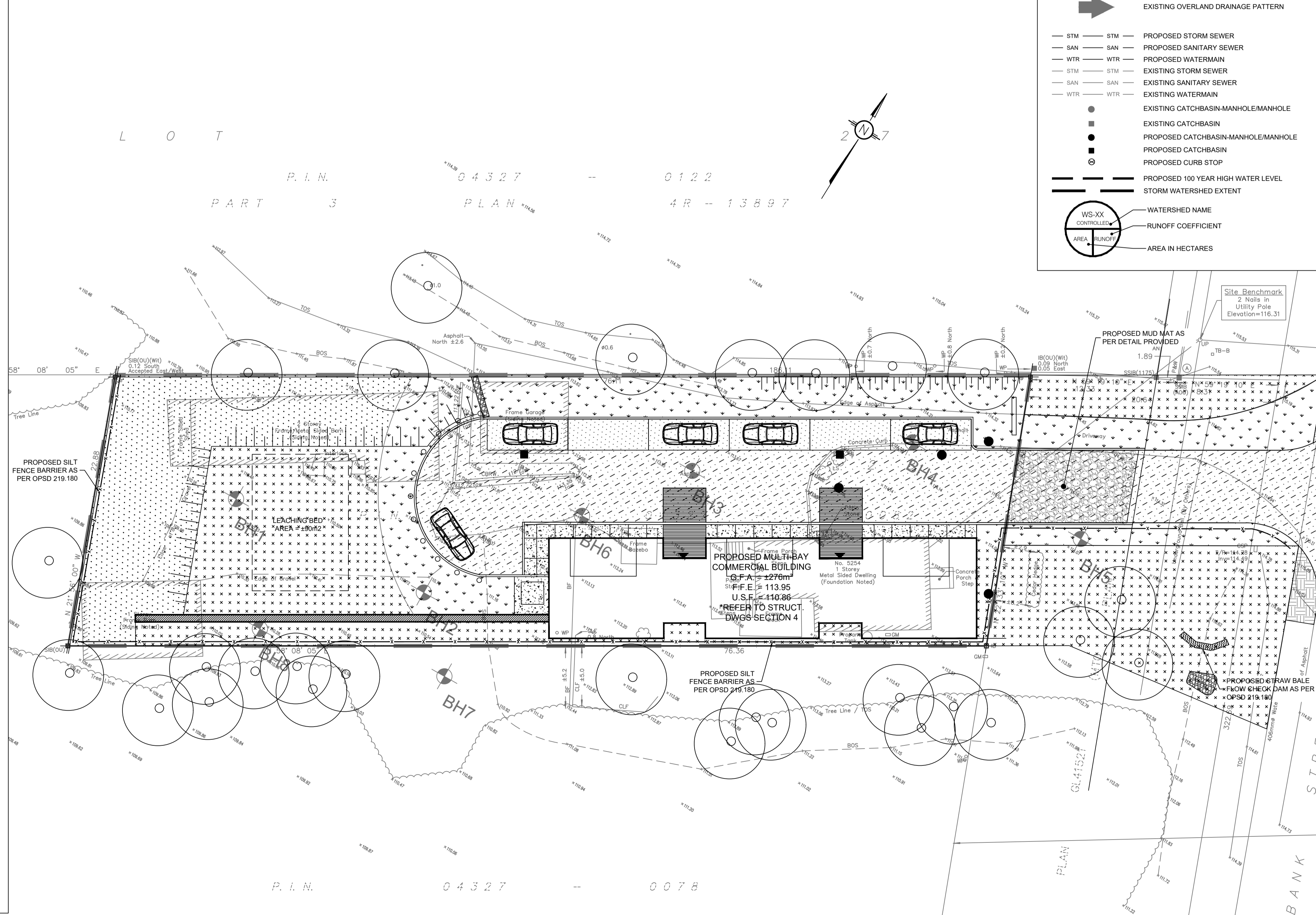

**NOT FOR CONSTRUCTION TENDER OR PERMIT**

No.	REVISIONS	BY	DATE
04	RE-ISSUED FOR SITE PLAN CONTROL	K.H.	27 JUN 2025
03	RE-ISSUED FOR SITE PLAN CONTROL	K.H.	02 APR 2024
02	RE-ISSUED FOR SITE PLAN CONTROL	K.H.	13 SEPT 2023
01	RE-ISSUED FOR SITE PLAN CONTROL	K.H.	15 DEC 2022



NOT AUTHENTIC UNLESS SIGNED AND DATED

**LRJ**  
ENGINEERING | INGENIERIE  
5430 Canotek Road | Ottawa, ON, K1J 9G2  
www.lrl.ca | (613) 842-3434

CLIENT: **UNPOISED ARCHITECTURE INC**

DESIGNED BY: K.H. DRAWN BY: K.H. APPROVED BY: M.B.

PROJECT: **PROPOSED MULTI-UNIT COMMERCIAL DEVELOPMENT 5254 BANK STREET, OTTAWA**

DRAWING TITLE: **EROSION AND SEDIMENT CONTROL PLAN**

PROJECT NO: 220536  
DATE: JUNE 2022  
**C101**

**GENERAL NOTES**

1. ALL WORKS MATERIALS SHALL CONFORM TO THE LAST REVISION OF THE STANDARDS AND SPECIFICATIONS FOR THE CITY OF OTTAWA, ONTARIO PROVINCIAL STANDARD DRAWINGS (OPSD) AND SPECIFICATIONS (OPSS), WHERE APPLICABLE. LOCAL UTILITY STANDARDS AND MINISTRY OF TRANSPORTATION STANDARDS WILL APPLY WHERE REQUIRED.
2. THE CONTRACTORS SHALL CONFIRM THE LOCATION OF ALL EXISTING UTILITIES WITHIN THE SITE AND ADJACENT WORK AREAS. THE CONTRACTORS SHALL BE RESPONSIBLE FOR PROTECTING ALL EXISTING UTILITIES TO THE SATISFACTION OF THE AUTHORITY HAVING JURISDICTION. THE CONTRACTOR SHALL BE RESPONSIBLE FOR THE REPAIR OR REPLACEMENT OF ANY SERVICES OR UTILITIES DISTURBED DURING CONSTRUCTION. TO THE SATISFACTION OF THE AUTHORITY HAVING JURISDICTION.
3. ALL DIMENSIONS SHALL BE CHECKED AND VERIFIED IN THE FIELD BY THE CONTRACTOR PRIOR TO THE START OF CONSTRUCTION. ANY DISCREPANCIES SHALL BE REPORTED IMMEDIATELY TO THE ENGINEER. LOST TIME DUE TO FAILURE OF THE CONTRACTORS TO CONFIRM UTILITY LOCATIONS AND NOTIFY ENGINEER OF POSSIBLE CONFLICTS PRIOR TO CONSTRUCTION WILL BE AT CONTRACTORS EXPENSE.
4. ANY AREA BEYOND THE LIMIT OF THE SITE DISTURBED DURING CONSTRUCTION SHALL BE RESTORED TO ORIGINAL CONDITION OR BETTER TO THE SATISFACTION OF THE AUTHORITY HAVING JURISDICTION AT THE CONTRACTORS EXPENSE. RELOCATING OF EXISTING SERVICES AND/OR UTILITIES SHALL BE AS SHOWN ON THE DRAWINGS OR DETECTED BY THE ENGINEER AT THE EXPENSE OF DEVELOPERS.
5. ALL WORK SHALL BE COMPLETED IN ACCORDANCE WITH THE OCCUPATIONAL HEALTH AND SAFETY ACT AND REGULATIONS FOR CONSTRUCTION PROJECTS. THE GENERAL CONTRACTORS SHALL BE DEEMED TO BE THE CONTRACTOR AS DEFINED IN THE ACT.
6. ALL THE CONSTRUCTION SIGNAGE MUST CONFORM TO THE MINISTRY OF TRANSPORTATION OF ONTARIO MANUAL OF UNIFORM TRAFFIC CONTROL DEVICES PER LATEST AMENDMENT.
7. THE CONTRACTOR IS ADVISED THAT WORKS BY OTHERS MAY BE ONGOING DURING THE PERIOD OF THE CONTRACT. THE CONTRACTOR SHALL COORDINATE CONSTRUCTION ACTIVITIES TO PREVENT CONFLICTS.
8. ALL DIMENSIONS ARE IN METRES UNLESS SPECIFIED OTHERWISE.
9. THERE WILL BE NO SUBSTITUTION OF MATERIALS UNLESS PRIOR WRITTEN APPROVAL IS RECEIVED FROM THE ENGINEER.
10. ALL CONSTRUCTION SHALL BE CARRIED OUT IN ACCORDANCE WITH THE RECOMMENDATIONS MADE IN THE GEOTECHNICAL REPORT.
11. FOR DETAILS RELATING TO STORMWATER MANAGEMENT REFER TO THE SITE SERVICING AND STORMWATER MANAGEMENT REPORT.
12. ALL SEWERS CONSTRUCTED WITH GRADES LESS THAN 1.0% SHALL BE INSTALLED USING LASER ALIGNMENT AND CHECKED WITH LEVEL INSTRUMENT PRIOR TO BACKFILLING.
13. THE CONTRACTOR IS RESPONSIBLE FOR OBTAINING ALL PERMITS REQUIRED AND TO BEAR THE COST OF THE SAME.
14. THE CONTRACTOR SHALL BE RESPONSIBLE FOR ADDITIONAL BEDDING, OR ADDITIONAL STRENGTH PIPE IF THE MAXIMUM TRENCH WIDTH AS SPECIFIED BY OPSD IS EXCEEDED.
15. ALL PIPE/CULVERT SECTION SIZES REFER TO INSIDE DIMENSIONS.
16. SHOULD DEEPLY BURIED ARCHAEOLOGICAL REMAINS BE FOUND ON THE PROPERTY DURING CONSTRUCTION ACTIVITIES, THE HERITAGE OPERATIONS UNIT OF THE ONTARIO MINISTRY OF CULTURE MUST BE NOTIFIED IMMEDIATELY.
17. ALL NECESSARY CLEARING AND GRUBBING SHALL BE COMPLETED BY THE CONTRACTOR. REVIEW WITH CONTRACT ADMINISTRATOR AND THE CITY OF OTTAWA PRIOR TO ANY TREE CUTTING/REMOVAL.
18. DRAWINGS SHALL BE READ ON CONJUNCTION WITH ARCHITECTURAL SITE PLAN.
19. THE CONTRACTOR SHALL PROVIDE THE PROJECT ENGINEER ON SET OF AS CONSTRUCTED SITE SERVICING AND GRADING DRAWINGS.
20. BENCHMARKS: IT IS THE RESPONSIBILITY OF THE CONTRACTOR TO VERIFY THAT THE SITE BENCHMARK(S) HAS NOT BEEN ALTERED OR DISTURBED AND THAT ITS RELATIVE ELEVATION AND DESCRIPTION AGREES WITH THE INFORMATION DEPICTED ON THIS PLAN.

**SITE GRADING NOTES**

1. ALL GRANULAR AND PAVEMENT FOR ROADS/PARKING AREAS SHALL BE CONSTRUCTED IN ACCORDANCE WITH GEOTECHNICAL ENGINEER'S RECOMMENDATIONS (AS APPLICABLE).
2. ALL TOPSOIL AND ORGANIC MATERIAL SHALL BE STRIPPED WITHIN THE ROAD AND PARKING AREAS ALLOWANCE PRIOR TO THE COMMENCEMENT OF CONSTRUCTION.
3. PAVEMENT REINSTATEMENT FOR SERVICE AND UTILITY CUTS SHALL BE IN ACCORDANCE WITH THE CITY OF OTTAWA STD. R10 AND OPSD 509.010 AND OPSS 310.
4. GRANULAR 'A' SHALL BE PLACED TO A MINIMUM THICKNESS OF 300MM AROUND ALL STRUCTURES WITHIN THE PAVEMENT AREA.
5. SUB-EXCAVATE SOFT AREAS AND FILL WITH GRANULAR 'B' COMPACTED IN MAXIMUM 300MM LIFTS.
6. ALL WORK ON THE MUNICIPAL RIGHT OF WAY AND EASEMENTS TO BE INSPECTED BY THE MUNICIPALITY PRIOR BACKFILLING.
7. CONTRACTOR TO OBTAIN A ROAD OCCUPANCY PERMIT 48 HOURS PRIOR TO COMMENCING ANY WORK WITHIN THE MUNICIPAL ROAD ALLOWANCE, IF REQUIRED BY THE MUNICIPALITY.
8. ALL PAVEMENT MARKING FEATURES AND SITE SIGNAGE SHALL BE PLACED PER ARCHITECTURAL SITE PLAN, LINE PAINTING AND DIRECTIONAL SYMBOLS SHALL BE APPLIED WITH A MINIMUM OF TWO COATS OF ORGANIC SOLVENT PAINT.
9. REFER TO ARCHITECTURAL SITE PLAN FOR DIMENSIONS AND SITE DETAILS.
10. STEP JOINTS ARE TO BE USED WHERE PROPOSED ASPHALT MEETS EXISTING ASPHALT. ALL JOINTS MUST BE SEALED.
11. WHERE APPLICABLE THE CONTRACTOR IS TO SUBMIT SHOP DRAWINGS TO THE ENGINEER FOR APPROVAL PRIOR TO CONSTRUCTION. SHOP DRAWINGS MUST BE SITE SPECIFIC, SIGNED AND SEALED BY A LICENSED ENGINEER.

**ROADWORK SPECIFICATIONS**

12. ROADWORK TO BE COMPLETED IN ACCORDANCE WITH GEOTECHNICAL REPORT.
13. ALL TOPSOIL AND ORGANIC MATERIAL SHALL BE STRIPPED WITHIN THE ROAD ALLOWANCE PRIOR TO THE COMMENCEMENT OF CONSTRUCTION AND STOCK PILED ON SITE AS DIRECTED BY THE MUNICIPAL AUTHORITY.
14. THE SUBGRADE SHALL BE CROWNED AND SLOPED AT LEAST 2% AND PROOF ROLLED WITH HEAVY ROLLERS.
15. SUB-EXCAVATE SOFT AREAS AND FILL WITH GRANULAR 'A', TYPE II COMPACTED IN MAXIMUM 300MM LIFTS.
16. ALL GRANULAR FOR ROADS SHALL BE COMPACTED TO MINIMUM OF 100% STANDARD PROCTOR DENSITY MAXIMUM DRY DENSITY (SPMDD).

**PAVEMENT STRUCTURE**

COURSE	MATERIAL	THICKNESS (mm)	
		AUTOMOBILE PARKING	TRUCK ROUTE (HEAVY TRAFFIC)
SURFACE	HL-3 A/C (PG 58-28)	50	40
BINDER	HL-8 A/C (PG 58-28)	-	50
BASECOURSE	OPSS GRANULAR "A"	150	150
SUBBASE	OPSS GRANULAR "B" TYPE II	350	450

NOTE: IN PREPARATION FOR PAVEMENT CONSTRUCTION AT THIS SITE, ANY SURFICIAL OR NEAR SURFACE/SUBGRADE LEVEL TOPSOIL AND ANY SOFT, WET OR DELETERIOUS MATERIALS SHOULD BE REMOVED FROM THE PROPOSED PAVED AREAS. THE EXPOSED SUBGRADE SHOULD BE INSPECTED AND APPROVED BY GEOTECHNICAL PERSONNEL AND ANY SOFT AREAS EVIDENT SHOULD BE SUBCAVATED AND REPLACED WITH SUITABLE EARTH BORROW APPROVED BY THE GEOTECHNICAL ENGINEER. THE SUBGRADE SHOULD BE SHAPED AND CROWNED TO PROMOTE DRAINAGE OF THE SITE DRAINAGE STRUCTURES. FOLLOWING APPROVAL OF THE PREPARATION OF THE SUBGRADE, THE PAVEMENT GRANULARS MAY BE PLACED. REFER TO GEOTECHNICAL INVESTIGATION REPORT PREPARED BY LRL ASSOCIATES DATED JULY 2021.

**LEGEND:**

- EXISTING PROPERTY LINE TO REMAIN
- PROPOSED CURB
- PROPOSED DEPRESSED CURB
- PROPOSED TERRACING (3:1 MIN.)
- PROPOSED SILT FENCE AS PER OPSD 219.110
- PROPOSED DOOR ENTRANCE/EXIT
- PROPOSED GRASS AREA (100mm TOP SOIL & SOD)
- PROPOSED GRASS AREA (100mm TOP SOIL & SEED)
- PROPOSED CONCRETE FEATURES/SLAB
- PROPOSED HEAVY DUTY ASPHALT
- PROPOSED LIGHT DUTY ASPHALT
- PROPOSED GRAVEL SHOULDER
- PROPOSED RIP RAP
- PROPOSED ELEVATION
- PROPOSED HIGH POINT ELEVATION
- PROPOSED BOTTOM OF CURB / ASPHALT ELEVATION
- PROPOSED TOP OF CURB ELEVATION
- PROPOSED EXPOSED BOTTOM OF RETAINING WALL
- PROPOSED TOP OF RETAINING WALL
- MATCH INTO EXISTING ELEVATION
- EXISTING ELEVATION
- PROPOSED OVERLAND MAJOR FLOW ROUTE
- EXISTING OVERLAND DRAINAGE PATTERN
- STM - PROPOSED STORM SEWER
- SAN - PROPOSED SANITARY SEWER
- WTR - PROPOSED WATERMAIN
- STM - EXISTING STORM SEWER
- SAN - EXISTING SANITARY SEWER
- WTR - EXISTING WATERMAIN
- EXISTING CATCHBASIN-MANHOLE/MANHOLE
- EXISTING CATCHBASIN
- PROPOSED CATCHBASIN-MANHOLE/MANHOLE
- PROPOSED CATCHBASIN
- PROPOSED CURB STOP
- PROPOSED 100 YEAR HIGH WATER LEVEL
- STORM WATERSHED EXTENT
- WS-XX CONTROLLED - WATERSHED NAME
- AREA RUNOFF - RUNOFF COEFFICIENT
- AREA IN HECTARES

**USE AND INTERPRETATION OF DRAWINGS**

GENERAL CONDITIONS OF THE CONTRACT FOR CONSTRUCTION ARE PART OF THE CONTRACT DOCUMENTS AND DESCRIBE USE AND INTERPRETATION OF THE DRAWINGS. THE CONTRACT DOCUMENTS INCLUDE NOT ONLY THE DRAWINGS, BUT ALSO THE OWNER CONTRACTOR AGREEMENTS, CONDITIONS OF THE CONTRACT, SPECIFICATIONS, ADDENDA AND MODIFICATIONS ISSUED AFTER EXECUTION OF THE CONTRACT. THESE CONTRACT DOCUMENTS ARE COMPLEMENTARY, AND WHAT IS REQUIRED BY ANY ONE SHALL BE BINDING AS IF REQUIRED BY ALL. WORK NOT COMPLETELY DELINEATED HEREON SHALL BE CONSTRUCTED OF THE SAME MATERIALS AND DETAIL UNLESS OTHERWISE SHOWN. WORK SHOWN MORE COMPLETELY ELSEWHERE IN THE CONTRACT DOCUMENTS.

BY USE OF THE DRAWINGS FOR CONSTRUCTION OF THE PROJECT, THE OWNER CONFIRMS THAT HE HAS REVIEWED AND APPROVED THE DRAWINGS. THE CONTRACTOR CONFIRMS THAT HE HAS VISITED THE SITE, FAMILIARIZED HIMSELF WITH THE LOCAL CONDITIONS, VERIFIED FIELD DIMENSIONS AND CORRELATED THEIR OBSERVATIONS WITH THE REQUIREMENTS OF THE CONTRACT DOCUMENTS.

AS INSTRUMENTS OF SERVICE, ALL DRAWINGS, SPECIFICATIONS, CAD FILES OR OTHER ELECTRONIC MEDIA AND COPIES THEREOF FURNISHED BY THE ENGINEER ARE THEIR PROPERTY. THEY ARE TO BE USED ONLY FOR THIS PROJECT AND ARE NOT TO BE USED ON ANY OTHER PROJECT, INCLUDING REPEATS OF THE PROJECT. CHANGES TO THE DRAWINGS MAY ONLY BE MADE BY THE ENGINEER.

UNLESS THE REVISION TITLE IS "ISSUED FOR CONSTRUCTION", THESE DRAWINGS SHALL BE CONSIDERED PRELIMINARY AND SHALL NOT BE USED AS A CONSTRUCTION DOCUMENT.

THESE DRAWINGS ILLUSTRATE THE WORK TO BE DONE. THE ENGINEER IS NOT RESPONSIBLE FOR THE MEANS, METHODS, TECHNIQUES, SEQUENCES, AND PROCEDURES USED TO DO THE WORK, OR THE SAFETY ASPECTS OF CONSTRUCTION, AND NOTHING ON THESE DRAWINGS EXPRESSED OR IMPLIED CHANGES THIS CONDITION. CONTRACTOR SHALL DETERMINE ALL CONDITIONS AT THE SITE AND SHALL BE RESPONSIBLE FOR DETERMINING HOW THEY AFFECT THE WORK. SUBMITTAL OF A BID TO PERFORM THIS WORK IS ACKNOWLEDGEMENT OF THE RESPONSIBILITIES AND THAT THEY HAVE FULLY CONSIDERED IN PLANNING OF THE WORK, AND THE BID PRICE. NO CLAIMS FOR EXTRA CHARGES DUE TO THESE CONDITIONS WILL BE FORTHCOMING.

**UNAUTHORIZED CHANGES**

IN THE EVENT THE CLIENT, THE CLIENT'S CONTRACTORS OR SUBCONTRACTORS, OR ANYONE FOR WHOM THE CLIENT IS LEGALLY LIABLE MAKES OR PERMITS TO BE MADE ANY CHANGES TO ANY REPORTS, PLANS, SPECIFICATIONS OR OTHER CONSTRUCTION DOCUMENTS PREPARED BY LRL ASSOCIATES LTD. (LRL) WITHOUT OBTAINING LRL'S PRIOR WRITTEN CONSENT, THE CLIENT SHALL ASSUME FULL RESPONSIBILITY FOR THE RESULTS OF SUCH CHANGES. THEREFORE THE CLIENT AGREES TO WAIVE ANY CLAIM AGAINST LRL AND TO RELEASE LRL FROM ANY LIABILITY ARISING DIRECTLY OR INDIRECTLY FROM SUCH UNAUTHORIZED CHANGES.

IN ADDITION, THE CLIENT AGREES TO THE FULLEST EXTENT PERMITTED BY LAW, TO INDEMNIFY AND HOLD HARMLESS LRL FROM ANY DAMAGES, LIABILITIES OR COSTS, INCLUDING REASONABLE ATTORNEY'S FEES AND COST OF DEFENSE, ARISING FROM SUCH CHANGES.

IN ADDITION, THE CLIENT AGREES TO INCLUDE IN ANY CONTRACTS FOR CONSTRUCTION APPROPRIATE LANGUAGE THAT PROHIBITS THE CONTRACTOR OR ANY SUBCONTRACTORS OF ANY TIER FROM MAKING ANY CHANGES OR MODIFICATIONS TO LRL'S CONSTRUCTION DOCUMENTS WITHOUT THE PRIOR WRITTEN APPROVAL OF LRL, AND THAT REQUIRES THE CONTRACTOR TO INDEMNIFY BOTH LRL AND THE CLIENT FROM ANY LIABILITY OR COST ARISING FROM SUCH CHANGES MADE WITHOUT SUCH PROPER AUTHORIZATION.

**GENERAL NOTES:**

EXISTING SERVICES AND UTILITIES SHOWN ON THESE DRAWINGS ARE TAKEN FROM THE BEST AVAILABLE RECORDS, BUT MAY NOT BE COMPLETE OR UP TO DATE. CONTRACTOR SHALL VERIFY IN FIELD FOR LOCATION AND ELEVATION OF PIPES AND CHECK WITH THE UTILITY COMPANIES BEFORE DIGGING OR PERFORMING WORK.

CONTRACTOR IS ADVISED TO COLLECT INFORMATION ON SOIL CONDITIONS BEFORE START OF CONSTRUCTION.

THE ENGINEER WAIVES ANY AND ALL RESPONSIBILITY AND LIABILITY FOR PROBLEMS WHICH ARISE FROM FAILURE TO FOLLOW THESE PLANS, SPECIFICATIONS AND THE DESIGN INTENT THEY CONVEY, OR FOR PROBLEMS WHICH ARISE FROM OTHERS' FAILURE TO OBTAIN AND/OR FOLLOW THE ENGINEER'S GUIDANCE WITH RESPECT TO ANY ERRORS, OMISSIONS, INCONSISTENCIES AMBIGUITIES OR CONFLICTS WHICH ARE ALLEGED.

CONTRACTOR TO VERIFY ALL DIMENSIONS AND NOTIFY THE ENGINEER OF ANY DISCREPANCIES BEFORE WORK COMMENCES. DO NOT SCALE DRAWINGS.

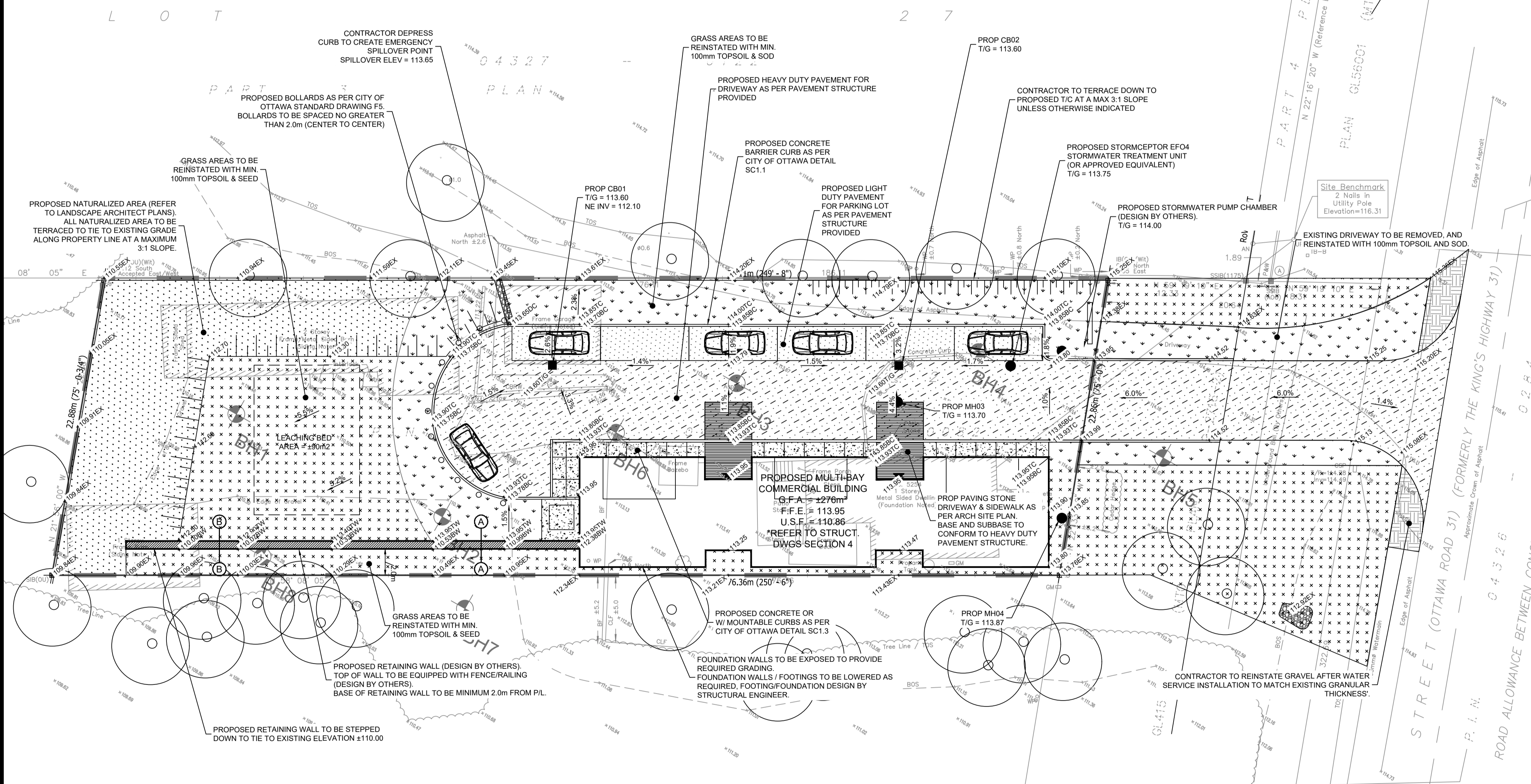

**Topographical Information**  
 Topographic information provided by Farley, Smith and Denis Surveying Ltd.  
 File No: 67-19  
 Dated: April 24th, 2019

**Metric Note**  
 Distances and coordinates on this plan are in metres and can be converted to feet by dividing by 0.3048.

**Distance Note**  
 Distances shown on this plan are ground distances and can be converted to grid distances by multiplying by the combined scale factor of 0.99995.

**Bearing Note**  
 Bearings are MTM grid, derived from the Can-Net Real Time Network.  
 GPS observations on reference points A and B, shown hereon, having a bearing of N 22° 16' 20" W and are referred to the Central Meridian of MTM Zone 9 (76° 30' West Longitude) Nad-83 (Original).

For bearing comparisons, a rotation of 6° 16' 20" counter-clockwise was applied to bearings on P1.  
 For bearing comparisons, a rotation of 0° 39' 20" counter-clockwise was applied to bearings on P2, P3, P4 & P5.

**Elevation Notes**

1. Elevations shown are geodetic and are referred to Geodetic Datum CGVD-1928-1978.
2. It is the responsibility of the user of this information to verify that the job benchmark has not been altered or disturbed and that its relative elevation and description agrees with the information shown on this drawing.

**Utility Notes**

1. This drawing cannot be accepted as acknowledging all of the utilities and it will be the responsibility of the user to contact the respective utility authorities for confirmation.
2. Only visible surface utilities were located.
3. Underground utility data derived from City of Ottawa utility sheet reference: 7123 (sheet 6).
4. A field location of underground plant by the pertinent utility authority is mandatory before any work involving breaking ground, probing, excavating etc.

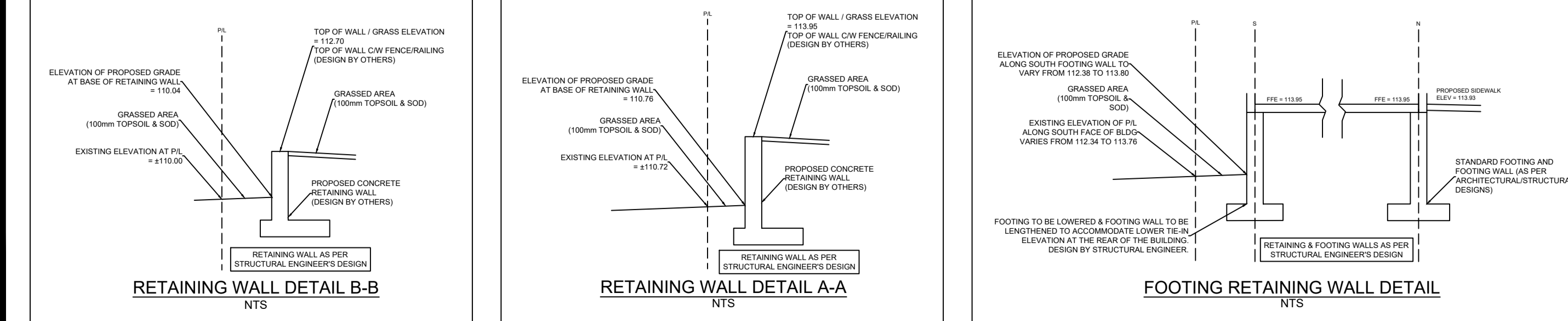

**NOT FOR CONSTRUCTION TENDER OR PERMIT**

No.	REVISIONS	BY	DATE
04	RE-ISSUED FOR SITE PLAN CONTROL	K.H.	27 JUN 2025
03	RE-ISSUED FOR SITE PLAN CONTROL	K.H.	02 APR 2024
02	RE-ISSUED FOR SITE PLAN CONTROL	K.H.	13 SEPT 2023
01	RE-ISSUED FOR SITE PLAN CONTROL	K.H.	15 DEC 2022



NOT AUTHENTIC UNLESS SIGNED AND DATED

**LRJ**  
 ENGINEERING | INGENIERIE  
 5430 Canotek Road | Ottawa, ON, K1J 9G2  
 www.lrl.ca | (613) 842-3434

CLIENT: UNPOISED ARCHITECTURE INC.

DESIGNED BY: K.H. DRAWN BY: K.H. APPROVED BY: M.B.

PROJECT: PROPOSED MULTI-UNIT COMMERCIAL DEVELOPMENT 5254 BANK STREET, OTTAWA

DRAWING TITLE: GRADING AND DRAINAGE PLAN

PROJECT NO: 220536  
 DATE: JUNE 2022  
**C301**

**SANITARY, FOUNDATION DRAIN, STORM SEWER AND WATERMAIN NOTES**

**GENERAL**

1. LASER ALIGNMENT CONTROL TO BE UTILIZED ON ALL SEWER INSTALLATIONS.
2. ALL MAINTENANCE STRUCTURE AND CATCH BASIN EXCAVATIONS TO BE BACKFILLED WITH GRANULAR MATERIAL COMPACTED TO 98% STANDARD PROCTOR DENSITY. A MINIMUM OF 300MM AROUND STRUCTURES.

**STORM**

3. ALL PVC STORM SEWERS ARE TO BE SDR 35 APPROVED PER C.S.A. B182.2 OR LATEST AMENDMENT, UNLESS OTHERWISE SPECIFIED.
4. CATCH BASIN SHALL BE IN ACCORDANCE WITH OPSD 705.010.
5. CATCH BASIN LEADS SHALL BE IN 200MM DIA. AT 1% SLOPE (MIN) UNLESS SPECIFIED OTHERWISE.
6. ALL CATCH BASINS SHALL HAVE 600MM SUMPS, UNLESS SPECIFIED OTHERWISE.
7. ALL CATCH BASIN LEAD INVERTS TO BE 1.5M BELOW FINISHED GRADE UNLESS SPECIFIED OTHERWISE.
8. THE STORM SEWER CLASSES HAVE BEEN DESIGNED BASED ON BEDDING CONDITIONS SPECIFIED ABOVE. WHERE THE SPECIFIED TRENCH WIDTH IS EXCEEDED, THE CONTRACTOR IS REQUIRED TO PROVIDE AND SHALL BE RESPONSIBLE FOR EXTRA TEMPORARY AND/OR PERMANENT REPAIRS MADE NECESSARY BY THE WIDENED TRENCH.
9. ALL STORM MANHOLES WITH PIPE LESS THAN 900MM IN DIAMETER SHALL BE CONSTRUCTED WITH A 300MM SUMP AS PER SDG, CLAUSE 6.2.6.

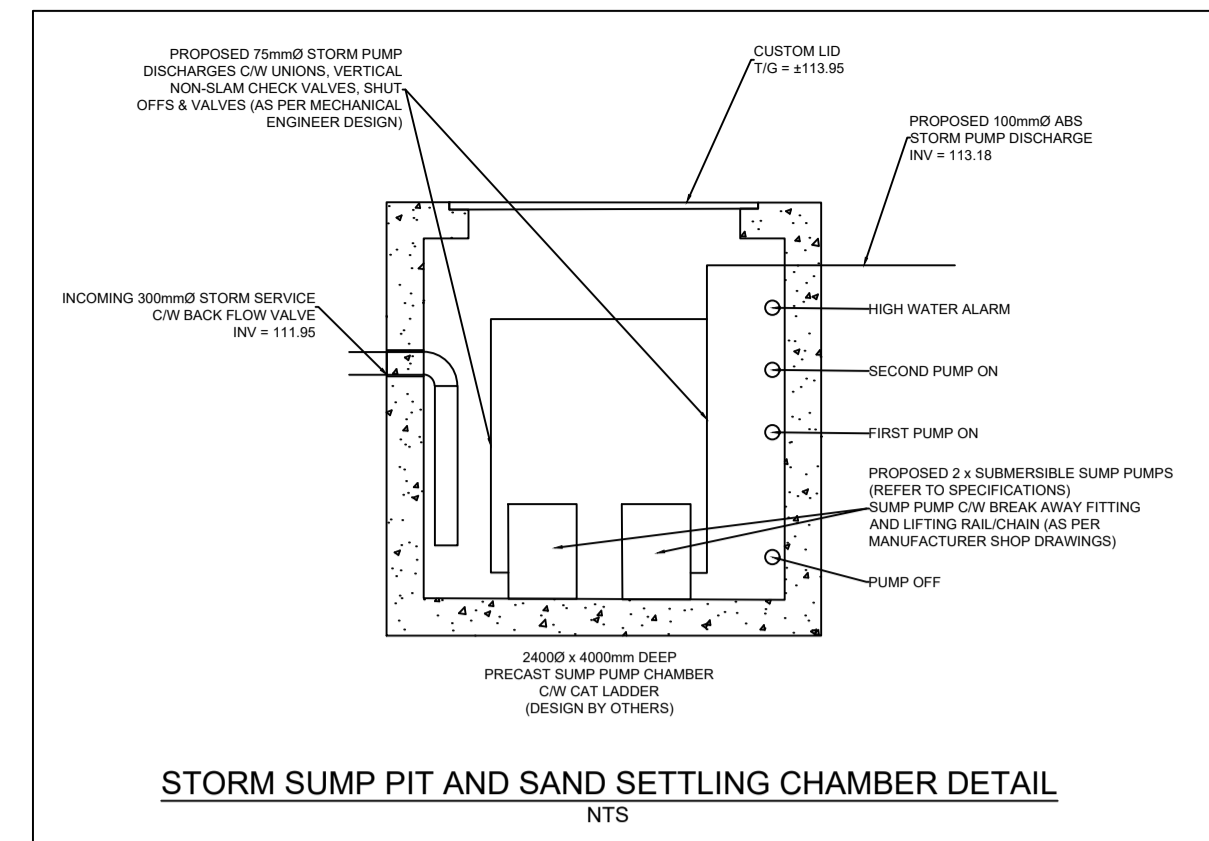

**LEGEND:**

- EXISTING PROPERTY LINE TO REMAIN
- PROPOSED CURB
- PROPOSED DEPRESSED CURB
- PROPOSED TERRACING (3:1 MIN.)
- PROPOSED SILT FENCE AS PER OPSD 219.110
- PROPOSED DOOR ENTRANCE/EXIT
- PROPOSED GRASS AREA (100mm TOP SOIL & SOD)
- PROPOSED GRASS AREA (100mm TOP SOIL & SEED)
- PROPOSED CONCRETE FEATURES/SLAB
- PROPOSED HEAVY DUTY ASPHALT
- PROPOSED LIGHT DUTY ASPHALT
- PROPOSED GRAVEL SHOULDER
- PROPOSED RIP RAP
- PROPOSED ELEVATION
- PROPOSED HIGH POINT ELEVATION
- PROPOSED BOTTOM OF CURB / ASPHALT ELEVATION
- PROPOSED TOP OF CURB ELEVATION
- PROPOSED EXPOSED BOTTOM OF RETAINING WALL
- PROPOSED TOP OF RETAINING WALL
- MATCH INTO EXISTING ELEVATION
- EXISTING ELEVATION
- PROPOSED OVERLAND MAJOR FLOW ROUTE
- EXISTING OVERLAND DRAINAGE PATTERN
- STM - PROPOSED STORM SEWER
- SAN - PROPOSED SANITARY SEWER
- WTR - PROPOSED WATERMAIN
- STM - EXISTING STORM SEWER
- SAN - EXISTING SANITARY SEWER
- WTR - EXISTING WATERMAIN
- EXISTING CATCHBASIN-MANHOLE/MANHOLE
- EXISTING CATCHBASIN
- PROPOSED CATCHBASIN-MANHOLE/MANHOLE
- PROPOSED CATCHBASIN
- PROPOSED CURB STOP
- PROPOSED 100 YEAR HIGH WATER LEVEL STORM WATERSHED EXTENT
- WS-XX CONTROLLED - WATERSHED NAME
- AREA RUNOFF - RUNOFF COEFFICIENT
- AREA IN HECTARES

**USE AND INTERPRETATION OF DRAWINGS**

GENERAL CONDITIONS OF THE CONTRACT FOR CONSTRUCTION ARE PART OF THE CONTRACT DOCUMENTS AND DESCRIBE USE AND INTENT OF THE DRAWINGS. THE CONTRACT DOCUMENTS INCLUDE NOT ONLY THE DRAWINGS, BUT ALSO THE OWNER CONTRACT AGREEMENTS, CONDITIONS OF THE CONTRACT, THE SPECIFICATIONS, ADDENDA, AND MODIFICATIONS ISSUED AFTER EXECUTION OF THE CONTRACT. THESE CONTRACT DOCUMENTS ARE COMPLEMENTARY, AND WHAT IS REQUIRED BY ANY ONE SHALL BE BINDING AS REQUIRED BY ALL. WORK NOT COMPLETELY DELINEATED HEREON SHALL BE CONSTRUCTED OF THE SAME MATERIALS AND DETAILED SIMILARLY AS WORK SHOWN MORE COMPLETELY ELSEWHERE IN THE CONTRACT DOCUMENTS.

BY USE OF THE DRAWINGS FOR CONSTRUCTION OF THE PROJECT, THE OWNER CONFIRMS THAT HE HAS REVIEWED AND APPROVED THE DRAWINGS. THE CONTRACTOR CONFIRMS THAT THEY HAVE VISITED THE SITE, FAMILIARIZED THEMSELVES WITH THE LOCAL CONDITIONS, VERIFIED FIELD DIMENSIONS AND CORRELATED THEIR OBSERVATIONS WITH THE REQUIREMENTS OF THE CONTRACT DOCUMENTS.

AS INSTRUMENTS OF SERVICE, ALL DRAWINGS, SPECIFICATIONS, CAD FILES OR OTHER ELECTRONIC MEDIA AND COPIES THEREOF FURNISHED BY THE ENGINEER ARE THEIR PROPERTY. THEY ARE TO BE USED ONLY FOR THIS PROJECT AND ARE NOT TO BE USED ON ANY OTHER PROJECT, INCLUDING REPEATS OF THE PROJECT. CHANGES TO THE DRAWINGS MAY ONLY BE MADE BY THE ENGINEER.

UNLESS THE REVISION TITLE IS "ISSUED FOR CONSTRUCTION", THESE DRAWINGS SHALL BE CONSIDERED PRELIMINARY AND SHALL NOT BE USED AS A CONSTRUCTION DOCUMENT.

THESE DRAWINGS ILLUSTRATE THE WORK TO BE DONE. THE ENGINEER IS NOT RESPONSIBLE FOR THE MEANS, METHODS, TECHNIQUES, SEQUENCES, AND PROCEDURES USED TO DO THE WORK, OR THE SAFETY ASPECTS OF CONSTRUCTION, AND NOTHING ON THESE DRAWINGS EXPRESSED OR IMPLIED CHANGES THIS CONDITION. CONTRACTOR SHALL DETERMINE ALL CONDITIONS AT THE SITE AND SHALL BE RESPONSIBLE FOR DETERMINING HOW THEY AFFECT THE WORK. SUBMITTAL OF A BID TO PERFORM THIS WORK IS ACKNOWLEDGEMENT OF THE RESPONSIBILITIES AND THAT THEY HAVE BEEN FULLY CONSIDERED IN PLANNING OF THE WORK, AND THE BID PRICE. NO CLAIMS FOR EXTRA CHARGES DUE TO THESE CONDITIONS WILL BE FORTHCOMING.

**UNAUTHORIZED CHANGES:**

IN THE EVENT THE CLIENT, THE CLIENT'S CONTRACTORS OR SUBCONTRACTORS, OR ANYONE FOR WHOM THE CLIENT IS LEGALLY LIABLE MAKES OR PERMITS TO BE MADE ANY CHANGES TO ANY REPORTS, PLANS, SPECIFICATIONS OR OTHER CONSTRUCTION DOCUMENTS PREPARED BY ASSOCIATES LTD. (LRL) WITHOUT OBTAINING LRL'S PRIOR WRITTEN CONSENT, THE CLIENT SHALL ASSUME FULL RESPONSIBILITY FOR THE RESULTS OF SUCH CHANGES. THEREFORE THE CLIENT AGREES TO WAIVE ANY CLAIM AGAINST LRL AND TO RELEASE LRL FROM ANY LIABILITY ARISING DIRECTLY OR INDIRECTLY FROM SUCH UNAUTHORIZED CHANGES.

IN ADDITION, THE CLIENT AGREES TO THE FULLEST EXTENT PERMITTED BY LAW, TO INDEMNIFY AND HOLD HARMLESS LRL FROM ANY DAMAGES, LIABILITIES OR COSTS, INCLUDING REASONABLE ATTORNEY'S FEES AND COST OF DEFENSE, ARISING FROM SUCH CHANGES.

IN ADDITION, THE CLIENT AGREES TO INCLUDE IN ANY CONTRACTS FOR CONSTRUCTION APPROPRIATE LANGUAGE THAT PROHIBITS THE CONTRACTOR OR ANY SUBCONTRACTORS OF ANY TIER FROM MAKING ANY CHANGES OR MODIFICATIONS TO LRL'S CONSTRUCTION DOCUMENTS WITHOUT THE PRIOR WRITTEN APPROVAL OF LRL, AND THAT REQUIRES THE CONTRACTOR TO INDEMNIFY BOTH LRL AND THE CLIENT FROM ANY LIABILITY OR COST ARISING FROM SUCH CHANGES MADE WITHOUT SUCH PROPER AUTHORIZATION.

**GENERAL NOTES:**

EXISTING SERVICES AND UTILITIES SHOWN ON THESE DRAWINGS ARE TAKEN FROM THE BEST AVAILABLE RECORDS, BUT MAY NOT BE COMPLETE OR UP TO DATE. CONTRACTOR SHALL VERIFY IN FIELD FOR LOCATION AND ELEVATION OF PIPES AND CHECK WITH THE UTILITY COMPANIES BEFORE DIGGING OR PERFORMING WORK.

CONTRACTOR IS ADVISED TO COLLECT INFORMATION ON SOIL CONDITIONS BEFORE START OF CONSTRUCTION.

THE ENGINEER WAIVES ANY AND ALL RESPONSIBILITY AND LIABILITY FOR PROBLEMS WHICH ARISE FROM OTHERS' FAILURE TO OBTAIN AND/OR FOLLOW THE ENGINEER'S GUIDANCE WITH RESPECT TO ANY ERRORS, OMISSIONS, INCONSISTENCIES, AMBIGUITIES OR CONFLICTS WHICH ARE ALLEGED.

CONTRACTOR TO VERIFY ALL DIMENSIONS AND NOTIFY THE ENGINEER OF ANY DISCREPANCIES BEFORE WORK COMMENCES. DO NOT SCALE DRAWINGS.

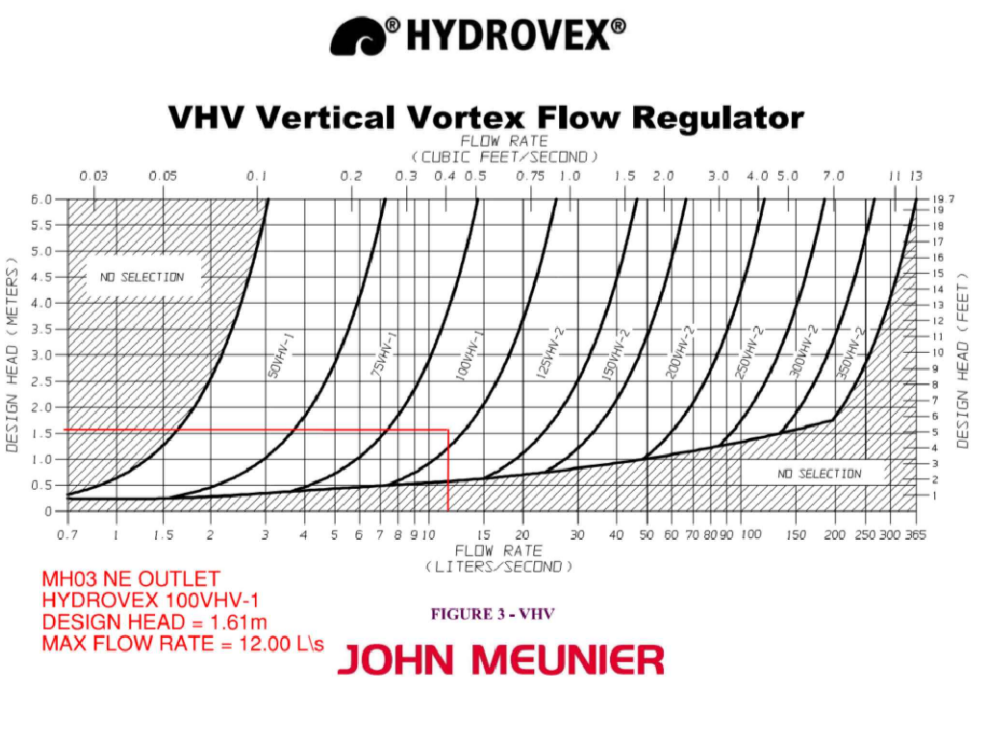
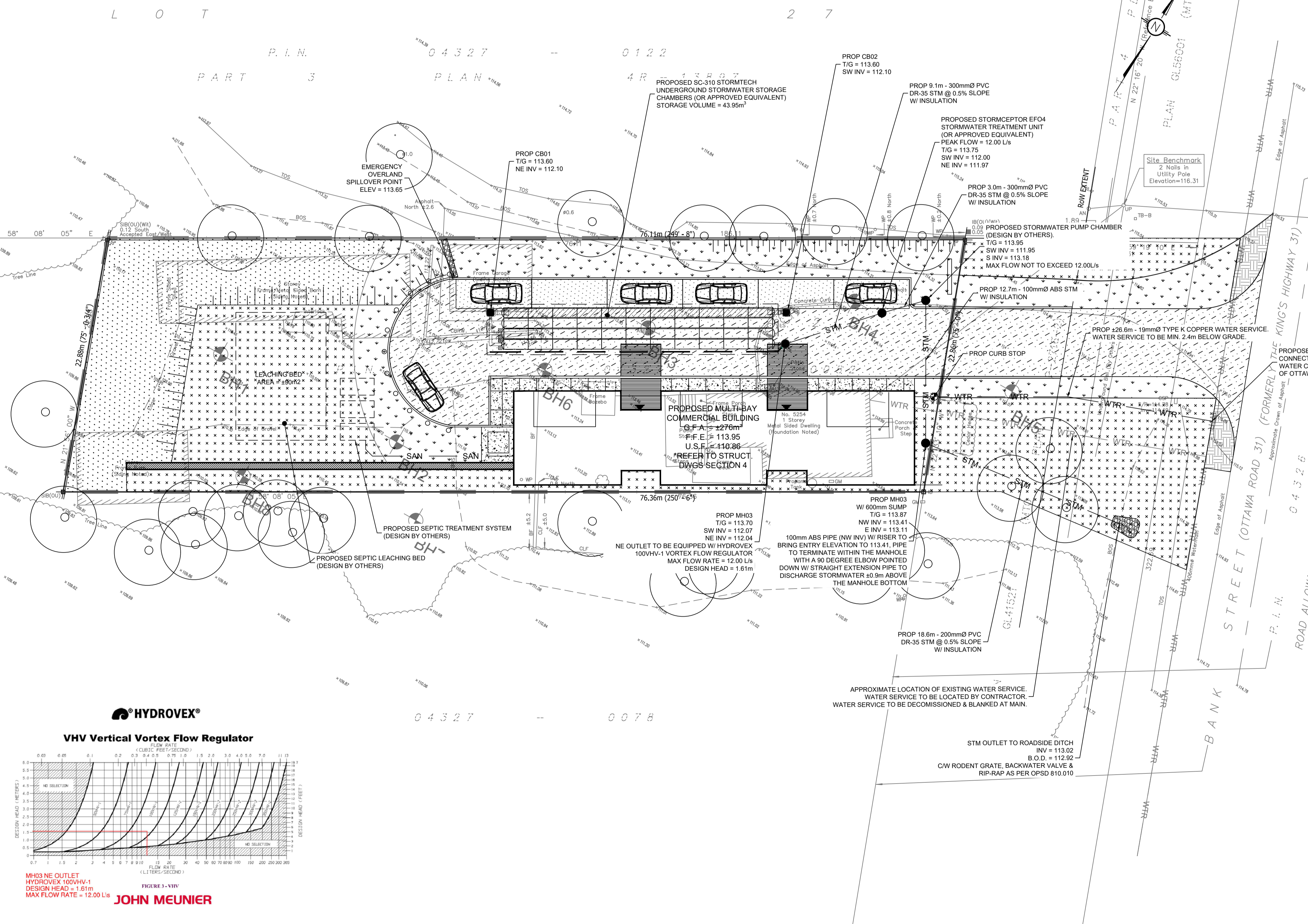

**NOT FOR CONSTRUCTION TENDER OR PERMIT**

No.	REVISIONS	BY	DATE
04	RE-ISSUED FOR SITE PLAN CONTROL	K.H.	27 JUN 2025
03	RE-ISSUED FOR SITE PLAN CONTROL	K.H.	02 APR 2024
02	RE-ISSUED FOR SITE PLAN CONTROL	K.H.	13 SEPT 2023
01	ISSUED FOR SITE PLAN CONTROL	K.H.	15 DEC 2022

**LICENCED PROFESSIONAL ENGINEER**  
M. BASNET  
100501996  
2024/16/27  
PROVINCE OF ONTARIO

NOT AUTHENTIC UNLESS SIGNED AND DATED

**LRJ**  
ENGINEERING | INGENIERIE  
5430 Canotek Road | Ottawa, ON, K1J 9G2  
www.lrl.ca | (613) 842-3434

CLIENT: UNPOISED ARCHITECTURE INC.

DESIGNED BY: K.H. DRAWN BY: K.H. APPROVED BY: M.B.

PROJECT: PROPOSED MULTI-UNIT COMMERCIAL DEVELOPMENT 5254 BANK STREET, OTTAWA

DRAWING TITLE: SERVICING PLAN

PROJECT NO: 220536 DATE: JUNE 2022

**C401**

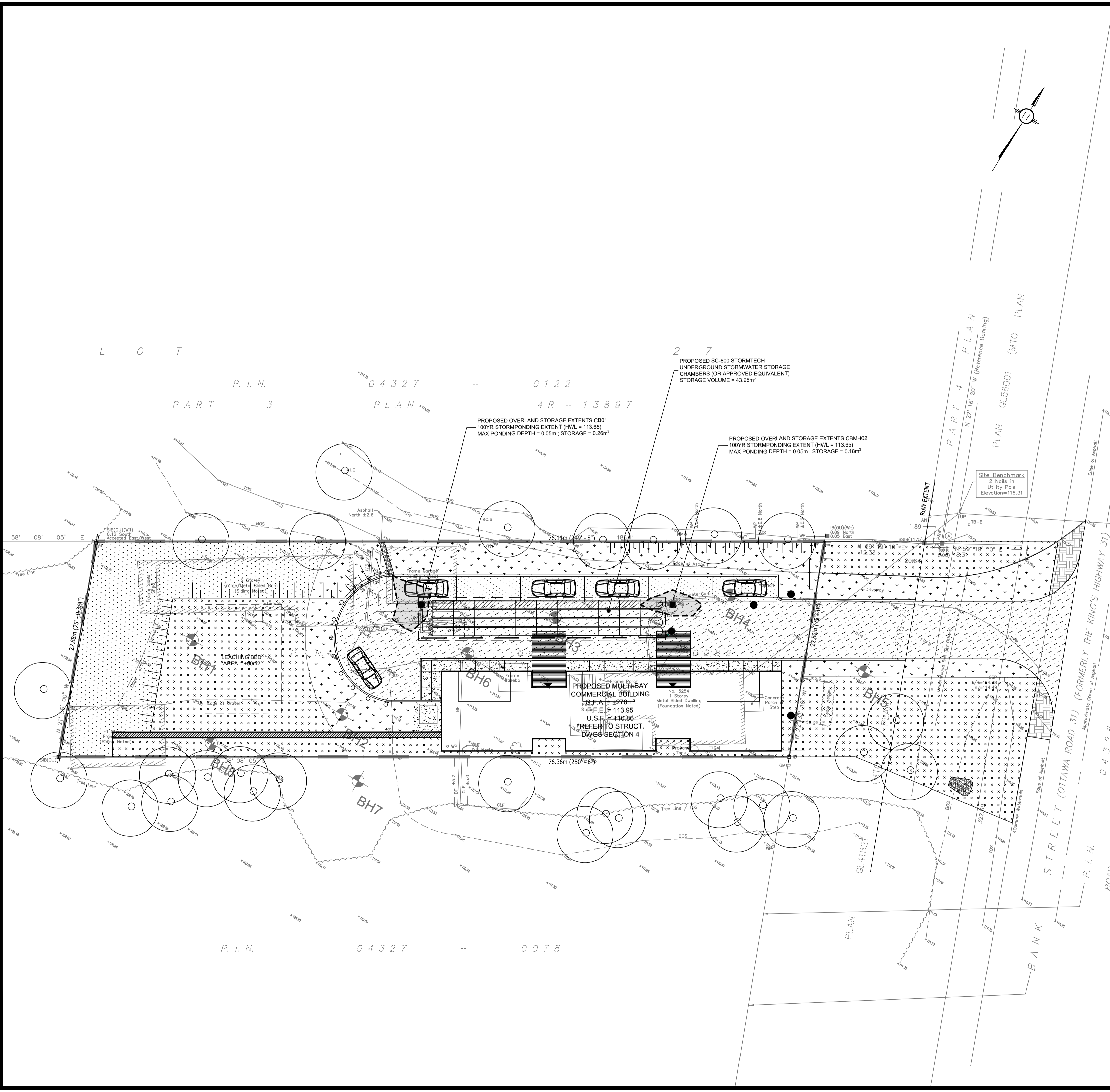

**LEGEND:**

- EXISTING PROPERTY LINE TO REMAIN
- PROPOSED CURB
- PROPOSED DEPRESSED CURB
- PROPOSED TERRACING (3:1 MIN.)
- PROPOSED SILT FENCE AS PER OPSS 219.110
- PROPOSED DOOR ENTRANCE/EXIT
- PROPOSED GRASS AREA (100mm TOP SOIL & SOD)
- PROPOSED GRASS AREA (100mm TOP SOIL & SEED)
- PROPOSED CONCRETE FEATURES/SLAB
- PROPOSED HEAVY DUTY ASPHALT
- PROPOSED LIGHT DUTY ASPHALT
- PROPOSED GRAVEL SHOULDER
- PROPOSED RIP RAP
- PROPOSED ELEVATION
- PROPOSED HIGH POINT ELEVATION
- PROPOSED BOTTOM OF CURB / ASPHALT ELEVATION
- PROPOSED TOP OF CURB ELEVATION
- PROPOSED EXPOSED BOTTOM OF RETAINING WALL
- PROPOSED TOP OF RETAINING WALL
- MATCH INTO EXISTING ELEVATION
- EXISTING ELEVATION
- PROPOSED OVERLAND MAJOR FLOW ROUTE
- EXISTING OVERLAND DRAINAGE PATTERN
- STM — PROPOSED STORM SEWER
- SAN — PROPOSED SANITARY SEWER
- WTR — PROPOSED WATERMAIN
- STM — EXISTING STORM SEWER
- SAN — EXISTING SANITARY SEWER
- WTR — EXISTING WATERMAIN
- EXISTING CATCHBASIN-MANHOLE/MANHOLE
- PROPOSED CATCHBASIN-MANHOLE/MANHOLE
- PROPOSED CATCHBASIN
- PROPOSED CURB STOP
- PROPOSED 100 YEAR HIGH WATER LEVEL STORM WATERSHED EXTENT
- WS-XX CONTROLLED — WATERSHED NAME
- AREA RUNOFF — RUNOFF COEFFICIENT
- AREA IN HECTARES

**USE AND INTERPRETATION OF DRAWINGS**

GENERAL CONDITIONS OF THE CONTRACT FOR CONSTRUCTION ARE PART OF THE CONTRACT DOCUMENTS AND DESCRIBE THE USE AND INTENT OF THE DRAWINGS. THE CONTRACT DOCUMENTS INCLUDE NOT ONLY THE DRAWINGS, BUT ALSO THE OWNER-CONTRACTOR AGREEMENTS, CONDITIONS OF THE CONTRACT, THE SPECIFICATIONS, ADDENDA, AND MODIFICATIONS ISSUED AFTER EXECUTION OF THE CONTRACT. THESE CONTRACT DOCUMENTS ARE COMPLEMENTARY, AND WHAT IS REQUIRED BY ANY ONE SHALL BE BINDING AS IF REQUIRED BY ALL. WORK NOT COMPLETELY DELINEATED HEREON SHALL BE CONSTRUCTED OF THE SAME MATERIALS AND DETAILED SIMILARLY AS WORK SHOWN MORE COMPLETELY ELSEWHERE IN THE CONTRACT DOCUMENTS.

BY USE OF THE DRAWINGS FOR CONSTRUCTION OF THE PROJECT, THE OWNER CONFIRMS THAT HE HAS REVIEWED AND APPROVED THE DRAWINGS. THE CONTRACTOR CONFIRMS THAT THEY HAVE VISITED THE SITE, FAMILIARIZED THEMSELVES WITH THE LOCAL CONDITIONS, VERIFIED FIELD DIMENSIONS AND CORRELATED THEIR OBSERVATIONS WITH THE REQUIREMENTS OF THE CONTRACT DOCUMENTS.

AS INSTRUMENTS OF SERVICE, ALL DRAWINGS, SPECIFICATIONS, CAD FILES OR OTHER ELECTRONIC MEDIA AND COPIES THEREOF FURNISHED BY THE ENGINEER ARE THEIR PROPERTY. THEY ARE TO BE USED ONLY FOR THIS PROJECT AND ARE NOT TO BE USED ON ANY OTHER PROJECT, INCLUDING REPEATS OF THE PROJECT. CHANGES TO THE DRAWINGS MAY ONLY BE MADE BY THE ENGINEER.

UNLESS THE REVISION TITLE IS "ISSUED FOR CONSTRUCTION", THESE DRAWINGS SHALL BE CONSIDERED PRELIMINARY AND SHALL NOT BE USED AS A CONSTRUCTION DOCUMENT.

THESE DRAWINGS ILLUSTRATE THE WORK TO BE DONE. THE ENGINEER IS NOT RESPONSIBLE FOR THE MEANS, METHODS, TECHNIQUES, SEQUENCES, AND PROCEDURES USED TO DO THE WORK, OR THE SAFETY ASPECTS OF CONSTRUCTION, AND NOTHING ON THESE DRAWINGS EXPRESSED OR IMPLIED CHANGES THIS CONDITION. CONTRACTOR SHALL DETERMINE ALL CONDITIONS AT THE SITE AND SHALL BE RESPONSIBLE FOR DETERMINING HOW THEY AFFECT THE WORK. SUBMITTAL OF A BID TO PERFORM THIS WORK IS ACKNOWLEDGEMENT OF THE RESPONSIBILITIES AND THAT THEY HAVE BEEN FULLY CONSIDERED IN PLANNING OF THE WORK, AND THE BID PRICE. NO CLAIMS FOR EXTRA CHARGES DUE TO THESE CONDITIONS WILL BE FORTHCOMING.

**UNAUTHORIZED CHANGES:**

IN THE EVENT THE CLIENT, THE CLIENT'S CONTRACTORS OR SUBCONTRACTORS, OR ANYONE FOR WHOM THE CLIENT IS LEGALLY LIABLE MAKES OR PERMITS TO BE MADE ANY CHANGES TO ANY REPORTS, PLANS, SPECIFICATIONS OR OTHER CONSTRUCTION DOCUMENTS PREPARED BY ASSOCIATES LTD (LRL) WITHOUT OBTAINING LRL'S PRIOR WRITTEN CONSENT, THE CLIENT SHALL ASSUME FULL RESPONSIBILITY FOR THE RESULTS OF SUCH CHANGES. THEREFORE THE CLIENT AGREES TO WAIVE ANY CLAIM AGAINST LRL AND TO RELEASE LRL FROM ANY LIABILITY ARISING DIRECTLY OR INDIRECTLY FROM SUCH UNAUTHORIZED CHANGES.

IN ADDITION, THE CLIENT AGREES TO THE FULLEST EXTENT PERMITTED BY LAW, TO INDEMNIFY AND HOLD HARMLESS LRL FROM ANY DAMAGES, LIABILITIES OR COSTS, INCLUDING REASONABLE ATTORNEY'S FEES AND COST OF DEFENSE, ARISING FROM SUCH CHANGES.

IN ADDITION, THE CLIENT AGREES TO INCLUDE IN ANY CONTRACTS FOR CONSTRUCTION APPROPRIATE LANGUAGE THAT PROHIBITS THE CONTRACTOR OR ANY SUBCONTRACTORS OF ANY TIER FROM MAKING ANY CHANGES OR MODIFICATIONS TO LRL'S CONSTRUCTION DOCUMENTS WITHOUT THE PRIOR WRITTEN APPROVAL OF LRL, AND THAT REQUIRES THE CONTRACTOR TO INDEMNIFY BOTH LRL AND THE CLIENT FROM ANY LIABILITY OR COST ARISING FROM SUCH CHANGES MADE WITHOUT SUCH PROPER AUTHORIZATION.

**GENERAL NOTES:**

EXISTING SERVICES AND UTILITIES SHOWN ON THESE DRAWINGS ARE TAKEN FROM THE BEST AVAILABLE RECORDS, BUT MAY NOT BE COMPLETE OR TO DATE. CONTRACTOR SHALL VERIFY IN FIELD FOR LOCATION AND ELEVATION OF PIPES AND CHECK WITH THE UTILITY COMPANIES BEFORE DIGGING OR PERFORMING WORK.

CONTRACTOR IS ADVISED TO COLLECT INFORMATION ON SOIL CONDITIONS BEFORE START OF CONSTRUCTION.

THE ENGINEER WAIVES ANY AND ALL RESPONSIBILITY AND LIABILITY FOR PROBLEMS WHICH ARISE FROM FAILURE TO FOLLOW THESE PLANS, SPECIFICATIONS AND THE DESIGN INTENT THEY CONVEY, OR FOR PROBLEMS WHICH ARISE FROM OTHERS FAILURE TO OBTAIN AND/OR FOLLOW THE ENGINEER'S GUIDANCE WITH RESPECT TO ANY ERRORS, OMISSIONS, INCONSISTENCIES AMBIGUITIES OR CONFLICTS WHICH ARE ALLEGED.

CONTRACTOR TO VERIFY ALL DIMENSIONS AND NOTIFY THE ENGINEER OF ANY DISCREPANCIES BEFORE WORK COMMENCES. DO NOT SCALE DRAWINGS.

SCALE: 1:200

**NOT FOR CONSTRUCTION TENDER OR PERMIT**

No.	REVISIONS	BY	DATE
04	RE-ISSUED FOR SITE PLAN CONTROL	K.H.	27 JUN 2025
03	RE-ISSUED FOR SITE PLAN CONTROL	K.H.	02 APR 2024
02	RE-ISSUED FOR SITE PLAN CONTROL	K.H.	13 SEPT 2023
01	ISSUED FOR SITE PLAN CONTROL	K.H.	15 DEC 2022



NOT AUTHENTIC UNLESS SIGNED AND DATED

**LRJ**  
ENGINEERING | INGENIERIE  
5430 Canotek Road | Ottawa, ON, K1J 9G2  
www.lrl.ca | (613) 842-3434

CLIENT  
**UNPOISED ARCHITECTURE INC**

DESIGNED BY: K.H. DRAWN BY: K.H. APPROVED BY: M.B.  
PROJECT  
**PROPOSED MULTI-UNIT COMMERCIAL DEVELOPMENT 5254 BANK STREET, OTTAWA**

DRAWING TITLE  
**STORMWATER MANAGEMENT PLAN**

PROJECT NO.  
**220536**  
DATE  
**JUNE 2022**

**C601**

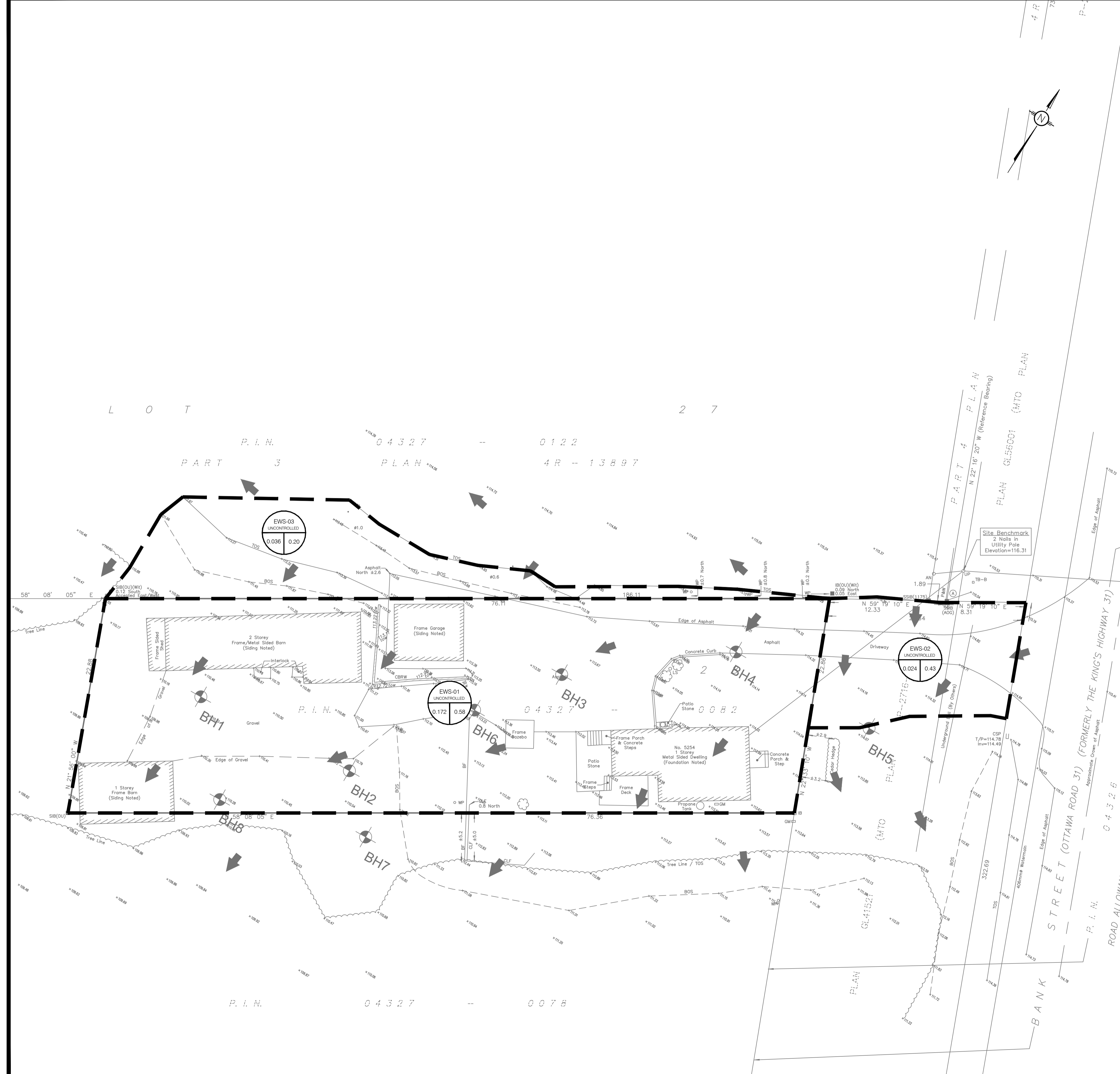

**LEGEND:**

- EXISTING PROPERTY LINE TO REMAIN
- PROPOSED CURB
- PROPOSED DEPRESSED CURB
- PROPOSED TERRACING (3:1 MIN.)
- PROPOSED SILT FENCE AS PER OPD 219.110
- PROPOSED DOOR ENTRANCE/EXIT
- PROPOSED GRASS AREA (100mm TOP SOIL & SOD)
- PROPOSED GRASS AREA (100mm TOP SOIL & SEED)
- PROPOSED CONCRETE FEATURES/SLAB
- PROPOSED HEAVY DUTY ASPHALT
- PROPOSED LIGHT DUTY ASPHALT
- PROPOSED GRAVEL SHOULDER
- PROPOSED RIP RAP
- PROPOSED ELEVATION
- PROPOSED HIGH POINT ELEVATION
- PROPOSED BOTTOM OF CURB / ASPHALT ELEVATION
- PROPOSED TOP OF CURB ELEVATION
- PROPOSED EXPOSED BOTTOM OF RETAINING WALL
- PROPOSED TOP OF RETAINING WALL
- MATCH INTO EXISTING ELEVATION
- EXISTING ELEVATION
- PROPOSED OVERLAND MAJOR FLOW ROUTE
- EXISTING OVERLAND DRAINAGE PATTERN
- STM — PROPOSED STORM SEWER
- SAN — PROPOSED SANITARY SEWER
- WTR — PROPOSED WATERMAIN
- STM — EXISTING STORM SEWER
- SAN — EXISTING SANITARY SEWER
- WTR — EXISTING WATERMAIN
- EXISTING CATCHBASIN-MANHOLE/MANHOLE
- PROPOSED CATCHBASIN-MANHOLE/MANHOLE
- PROPOSED CATCHBASIN
- PROPOSED CURB STOP
- PROPOSED 100 YEAR HIGH WATER LEVEL STORM WATERSHED EXTENT
- WS-XX — WATERSHED NAME
- — RUNOFF COEFFICIENT
- — AREA IN HECTARES

**USE AND INTERPRETATION OF DRAWINGS**

GENERAL CONDITIONS OF THE CONTRACT FOR CONSTRUCTION ARE PART OF THE CONTRACT DOCUMENTS AND DESCRIBE THE USE AND INTENT OF THE DRAWINGS. THE CONTRACT DOCUMENTS INCLUDE NOT ONLY THE DRAWINGS, BUT ALSO THE OWNER-CONTRACTOR AGREEMENT, CONDITIONS OF THE CONTRACT, THE SPECIFICATIONS, ADDENDA, AND MODIFICATIONS ISSUED AFTER EXECUTION OF THE CONTRACT. THESE CONTRACT DOCUMENTS ARE COMPLEMENTARY, AND WHAT IS REQUIRED BY ANY ONE SHALL BE BINDING AS IF REQUIRED BY ALL. WORK NOT COMPLETELY DELINEATED HEREON SHALL BE CONSTRUCTED OF THE SAME MATERIALS AND DETAILED SIMILARLY AS WORK SHOWN MORE COMPLETELY ELSEWHERE IN THE CONTRACT DOCUMENTS.

BY USE OF THE DRAWINGS FOR CONSTRUCTION OF THE PROJECT, THE OWNER CONFIRMS THAT HE HAS REVIEWED AND APPROVED THE DRAWINGS. THE CONTRACTOR CONFIRMS THAT THEY HAVE VISITED THE SITE, FAMILIARIZED THEMSELVES WITH THE LOCAL CONDITIONS, VERIFIED FIELD DIMENSIONS AND CORRELATED THEIR OBSERVATIONS WITH THE REQUIREMENTS OF THE CONTRACT DOCUMENTS.

AS INSTRUMENTS OF SERVICE, ALL DRAWINGS, SPECIFICATIONS, CAD FILES OR OTHER ELECTRONIC MEDIA AND COPIES THEREOF FURNISHED BY THE ENGINEER ARE THEIR PROPERTY. THEY ARE TO BE USED ONLY FOR THIS PROJECT AND ARE NOT TO BE USED ON ANY OTHER PROJECT, INCLUDING REPEATS OF THE PROJECT. CHANGES TO THE DRAWINGS MAY ONLY BE MADE BY THE ENGINEER.

UNLESS THE REVISION TITLE IS "ISSUED FOR CONSTRUCTION", THESE DRAWINGS SHALL BE CONSIDERED PRELIMINARY AND SHALL NOT BE USED AS A CONSTRUCTION DOCUMENT.

THESE DRAWINGS ILLUSTRATE THE WORK TO BE DONE. THE ENGINEER IS NOT RESPONSIBLE FOR THE MEANS, METHODS, TECHNIQUES, SEQUENCES, AND PROCEDURES USED TO DO THE WORK, OR THE SAFETY ASPECTS OF CONSTRUCTION, AND NOTHING ON THESE DRAWINGS EXPRESSED OR IMPLIED CHANGES THIS CONDITION. CONTRACTOR SHALL DETERMINE ALL CONDITIONS AT THE SITE AND SHALL BE RESPONSIBLE FOR KNOWING HOW THEY AFFECT THE WORK. SUBMITTAL OF A BID TO PERFORM THIS WORK IS ACKNOWLEDGEMENT OF THE RESPONSIBILITIES AND THAT THEY HAVE BEEN FULLY CONSIDERED IN PLANNING OF THE WORK, AND THE BID PRICE. NO CLAIMS FOR EXTRA CHARGES DUE TO THESE CONDITIONS WILL BE FORTHCOMING.

**UNAUTHORIZED CHANGES:**

IN THE EVENT THE CLIENT, THE CLIENT'S CONTRACTORS OR SUBCONTRACTORS, OR ANYONE FOR WHOM THE CLIENT IS LEGALLY LIABLE MAKES OR PERMITS TO BE MADE ANY CHANGES TO ANY REPORTS, PLANS, SPECIFICATIONS OR OTHER CONSTRUCTION DOCUMENTS PREPARED BY LRL ASSOCIATES LTD (LRL) WITHOUT OBTAINING LRL'S PRIOR WRITTEN CONSENT, THE CLIENT SHALL ASSUME FULL RESPONSIBILITY FOR THE RESULTS OF SUCH CHANGES. THEREFORE THE CLIENT AGREES TO WAIVE ANY CLAIM AGAINST LRL AND TO RELEASE LRL FROM ANY LIABILITY ARISING DIRECTLY OR INDIRECTLY FROM SUCH UNAUTHORIZED CHANGES.

IN ADDITION, THE CLIENT AGREES TO THE FULLEST EXTENT PERMITTED BY LAW, TO INDEMNIFY AND HOLD HARMLESS LRL FROM ANY DAMAGES, LIABILITIES OR COSTS, INCLUDING REASONABLE ATTORNEY'S FEES AND COST OF DEFENSE, ARISING FROM SUCH CHANGES.

IN ADDITION, THE CLIENT AGREES TO INCLUDE IN ANY CONTRACTS FOR CONSTRUCTION APPROPRIATE LANGUAGE THAT PROHIBITS THE CONTRACTOR OR ANY SUBCONTRACTORS OF ANY TIER FROM MAKING ANY CHANGES OR MODIFICATIONS TO LRL'S CONSTRUCTION DOCUMENTS WITHOUT THE PRIOR WRITTEN APPROVAL OF LRL, AND THAT REQUIRES THE CONTRACTOR TO INDEMNIFY BOTH LRL AND THE CLIENT FROM ANY LIABILITY OR COST ARISING FROM SUCH CHANGES MADE WITHOUT SUCH PROPER AUTHORIZATION.

**GENERAL NOTES:**

EXISTING SERVICES AND UTILITIES SHOWN ON THESE DRAWINGS ARE TAKEN FROM THE BEST AVAILABLE RECORDS, BUT MAY NOT BE COMPLETE OR TO DATE. CONTRACTOR SHALL VERIFY IN FIELD FOR LOCATION AND ELEVATION OF PIPES AND CHECK WITH THE UTILITY COMPANIES BEFORE DIGGING OR PERFORMING WORK.

CONTRACTOR IS ADVISED TO COLLECT INFORMATION ON SOIL CONDITIONS BEFORE START OF CONSTRUCTION.

THE ENGINEER WAIVES ANY AND ALL RESPONSIBILITY AND LIABILITY FOR PROBLEMS WHICH ARISE FROM FAILURE TO FOLLOW THESE PLANS, SPECIFICATIONS AND THE DESIGN INTENT THEY CONVEY, OR FOR PROBLEMS WHICH ARISE FROM OTHERS' FAILURE TO OBTAIN AND/OR FOLLOW THE ENGINEER'S GUIDANCE WITH RESPECT TO ANY ERRORS, OMISSIONS, INCONSISTENCIES AMBIGUITIES OR CONFLICTS WHICH ARE ALLEGED.

CONTRACTOR TO VERIFY ALL DIMENSIONS AND NOTIFY THE ENGINEER OF ANY DISCREPANCIES BEFORE WORK COMMENCES. DO NOT SCALE DRAWINGS.

SCALE: 1:200

CONTRACTOR IS ADVISED TO COLLECT INFORMATION ON SOIL CONDITIONS BEFORE START OF CONSTRUCTION.

**NOT FOR CONSTRUCTION TENDER OR PERMIT**

No.	REVISIONS	BY	DATE
04	RE-ISSUED FOR SITE PLAN CONTROL	K.H.	27 JUN 2025
03	RE-ISSUED FOR SITE PLAN CONTROL	K.H.	02 APR 2024
02	RE-ISSUED FOR SITE PLAN CONTROL	K.H.	13 SEPT 2023
01	ISSUED FOR SITE PLAN CONTROL	K.H.	15 DEC 2022



NOT AUTHENTIC UNLESS SIGNED AND DATED

**LRJ**  
ENGINEERING | INGENIERIE  
5430 Canotek Road | Ottawa, ON, K1J 9G2  
www.lrl.ca | (613) 842-3434

CLIENT: UNPOISED ARCHITECTURE INC

DESIGNED BY: K.H. DRAWN BY: K.H. APPROVED BY: M.B.

PROJECT: PROPOSED MULTI-UNIT COMMERCIAL DEVELOPMENT 5254 BANK STREET, OTTAWA

DRAWING TITLE: PRE-DEVELOPMENT WATERSHED PLAN

PROJECT NO: 220536  
DATE: JUNE 2022

**C701**

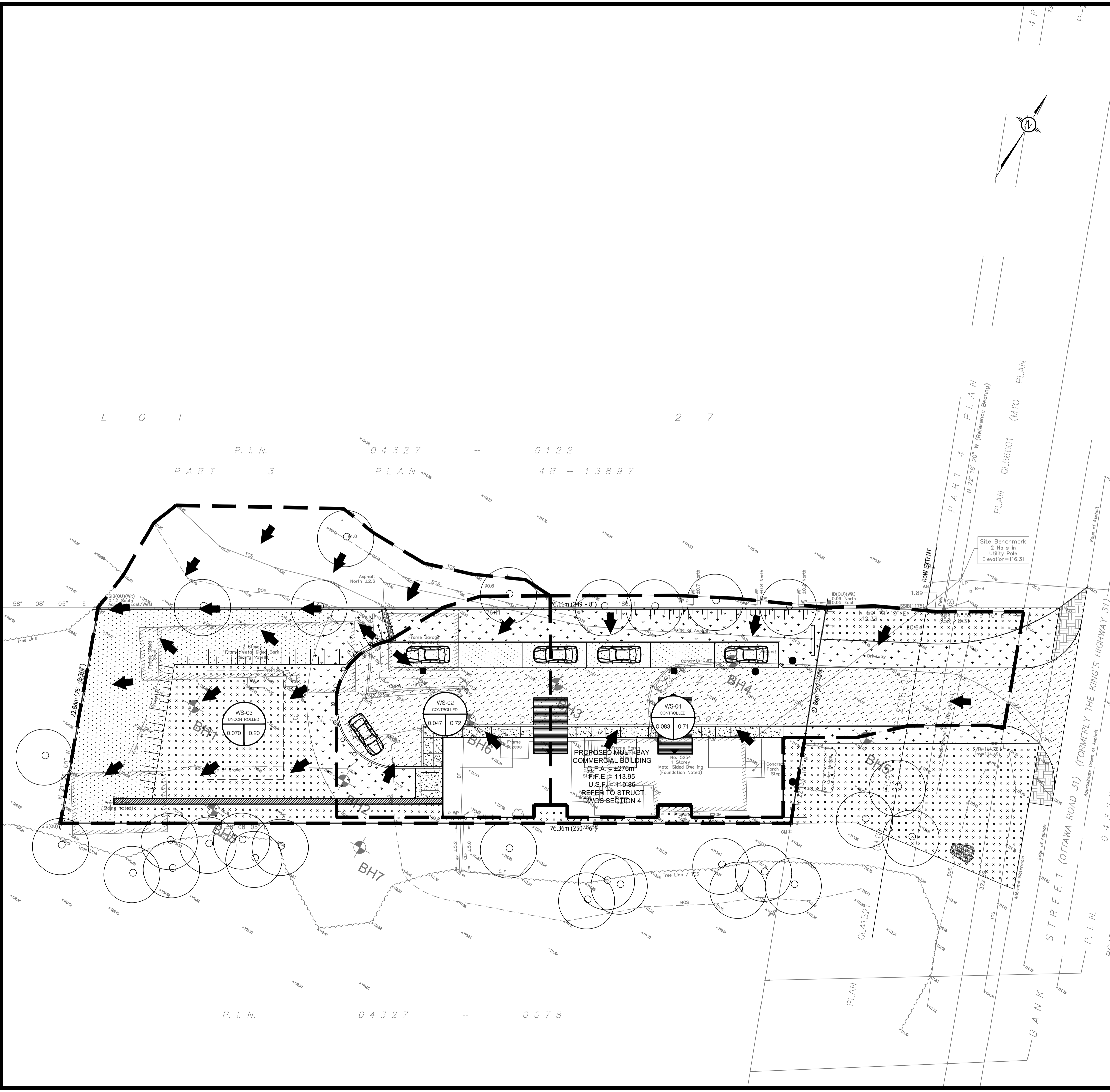

**LEGEND:**

- EXISTING PROPERTY LINE TO REMAIN
- PROPOSED CURB
- PROPOSED DEPRESSED CURB
- PROPOSED TERRACING (3:1 MIN.)
- PROPOSED SILT FENCE AS PER OPD 219.110
- PROPOSED DOOR ENTRANCE/EXIT
- PROPOSED GRASS AREA (100mm TOP SOIL & SOD)
- PROPOSED GRASS AREA (100mm TOP SOIL & SEED)
- PROPOSED CONCRETE FEATURES/SLAB
- PROPOSED HEAVY DUTY ASPHALT
- PROPOSED LIGHT DUTY ASPHALT
- PROPOSED GRAVEL SHOULDER
- PROPOSED RIP RAP
- PROPOSED ELEVATION
- PROPOSED HIGH POINT ELEVATION
- PROPOSED BOTTOM OF CURB / ASPHALT ELEVATION
- PROPOSED TOP OF CURB ELEVATION
- PROPOSED EXPOSED BOTTOM OF RETAINING WALL
- PROPOSED TOP OF RETAINING WALL
- MATCH INTO EXISTING ELEVATION
- EXISTING ELEVATION
- PROPOSED OVERLAND MAJOR FLOW ROUTE
- EXISTING OVERLAND DRAINAGE PATTERN
- PROPOSED STORM SEWER
- PROPOSED SANITARY SEWER
- EXISTING STORM SEWER
- EXISTING SANITARY SEWER
- EXISTING CATCHBASIN-MANHOLE/MANHOLE
- PROPOSED CATCHBASIN-MANHOLE/MANHOLE
- PROPOSED CATCHBASIN
- PROPOSED CURB STOP
- PROPOSED 100 YEAR HIGH WATER LEVEL STORM WATERSHED EXTENT
- WATERSHED NAME
- RUNOFF COEFFICIENT
- AREA IN HECTARES

**USE AND INTERPRETATION OF DRAWINGS**

GENERAL CONDITIONS OF THE CONTRACT FOR CONSTRUCTION ARE PART OF THE CONTRACT DOCUMENTS AND DESCRIBE THE USE AND INTENT OF THE DRAWING. THE CONTRACT DOCUMENTS INCLUDE NOT ONLY THE DRAWINGS, BUT ALSO THE OWNER-CONTRACTOR AGREEMENTS, CONDITIONS OF THE CONTRACT, THE SPECIFICATIONS, ADDENDA, AND MODIFICATIONS ISSUED AFTER EXECUTION OF THE CONTRACT. THESE CONTRACT DOCUMENTS ARE COMPLEMENTARY, AND WHAT IS REQUIRED BY ANY ONE SHALL BE BINDING AS IF REQUIRED BY ALL. WORK NOT COMPLETELY DELINEATED HEREON SHALL BE CONSTRUCTED OF THE SAME MATERIALS AND DETAILED SIMILARLY AS WORK SHOWN MORE COMPLETELY ELSEWHERE IN THE CONTRACT DOCUMENTS.

BY USE OF THE DRAWINGS FOR CONSTRUCTION OF THE PROJECT, THE OWNER CONFIRMS THAT HE HAS REVIEWED AND APPROVED THE DRAWINGS. THE CONTRACTOR CONFIRMS THAT THEY HAVE VISITED THE SITE, FAMILIARIZED THEMSELVES WITH THE LOCAL CONDITIONS, VERIFIED FIELD DIMENSIONS AND CORRELATED THEIR OBSERVATIONS WITH THE REQUIREMENTS OF THE CONTRACT DOCUMENTS.

AS INSTRUMENTS OF SERVICE, ALL DRAWINGS, SPECIFICATIONS, CAD FILES OR OTHER ELECTRONIC MEDIA AND COPIES THEREOF FURNISHED BY THE ENGINEER ARE THEIR PROPERTY. THEY ARE TO BE USED ONLY FOR THIS PROJECT AND ARE NOT TO BE USED ON ANY OTHER PROJECT, INCLUDING REPEATS OF THE PROJECT. CHANGES TO THE DRAWINGS MAY ONLY BE MADE BY THE ENGINEER.

UNLESS THE REVISION TITLE IS "ISSUED FOR CONSTRUCTION", THESE DRAWINGS SHALL BE CONSIDERED PRELIMINARY AND SHALL NOT BE USED AS A CONSTRUCTION DOCUMENT.

THESE DRAWINGS ILLUSTRATE THE WORK TO BE DONE. THE ENGINEER IS NOT RESPONSIBLE FOR THE MEANS, METHODS, TECHNIQUES, SEQUENCES, AND PROCEDURES USED TO DO THE WORK, OR THE SAFETY ASPECTS OF CONSTRUCTION, AND NOTHING ON THESE DRAWINGS EXPRESSED OR IMPLIED CHANGES THIS CONDITION. CONTRACTOR SHALL DETERMINE ALL CONDITIONS AT THE SITE AND SHALL BE RESPONSIBLE FOR DETERMINING HOW THEY AFFECT THE WORK. SUBMITTAL OF A BID TO PERFORM THIS WORK IS ACKNOWLEDGEMENT OF THE RESPONSIBILITIES AND THAT THEY HAVE BEEN FULLY CONSIDERED IN PLANNING OF THE WORK, AND THE BID PRICE. NO CLAIMS FOR EXTRA CHARGES DUE TO THESE CONDITIONS WILL BE FORTHCOMING.

**UNAUTHORIZED CHANGES:**

IN THE EVENT THE CLIENT, THE CLIENT'S CONTRACTORS OR SUBCONTRACTORS, OR ANYONE FOR WHOM THE CLIENT IS LEGALLY LIABLE MAKES OR PERMITS TO BE MADE ANY CHANGES TO ANY REPORTS, PLANS, SPECIFICATIONS OR OTHER CONSTRUCTION DOCUMENTS PREPARED BY ASSOCIATES LTD. (LAL) WITHOUT OBTAINING LAL'S PRIOR WRITTEN CONSENT, THE CLIENT SHALL ASSUME FULL RESPONSIBILITY FOR THE RESULTS OF SUCH CHANGES. THEREFORE THE CLIENT AGREES TO WAIVE ANY CLAIM AGAINST LAL AND TO RELEASE LAL FROM ANY LIABILITY ARISING DIRECTLY OR INDIRECTLY FROM SUCH UNAUTHORIZED CHANGES.

IN ADDITION, THE CLIENT AGREES TO THE FULLEST EXTENT PERMITTED BY LAW, TO INDEMNIFY AND HOLD HARMLESS LAL FROM ANY DAMAGES, LIABILITIES OR COSTS, INCLUDING REASONABLE ATTORNEY'S FEES AND COST OF DEFENSE, ARISING FROM SUCH CHANGES.

IN ADDITION, THE CLIENT AGREES TO INCLUDE IN ANY CONTRACTS FOR CONSTRUCTION APPROPRIATE LANGUAGE THAT PROHIBITS THE CONTRACTOR OR ANY SUBCONTRACTORS OF ANY TIER FROM MAKING ANY CHANGES OR MODIFICATIONS TO LAL'S CONSTRUCTION DOCUMENTS WITHOUT THE PRIOR WRITTEN APPROVAL OF LAL, AND THAT REQUIRES THE CONTRACTOR TO INDEMNIFY BOTH LAL AND THE CLIENT FROM ANY LIABILITY OR COST ARISING FROM SUCH CHANGES MADE WITHOUT SUCH PROPER AUTHORIZATION.

**GENERAL NOTES:**

EXISTING SERVICES AND UTILITIES SHOWN ON THESE DRAWINGS ARE TAKEN FROM THE BEST AVAILABLE RECORDS, BUT MAY NOT BE COMPLETE OR UP TO DATE. CONTRACTOR SHALL VERIFY IN FIELD FOR LOCATION AND ELEVATION OF PIPES AND CHECK WITH THE UTILITY COMPANIES BEFORE DIGGING OR PERFORMING WORK.

CONTRACTOR IS ADVISED TO COLLECT INFORMATION ON SOIL CONDITIONS BEFORE START OF CONSTRUCTION.

THE ENGINEER WAIVES ANY AND ALL RESPONSIBILITY AND LIABILITY FOR PROBLEMS WHICH ARISE FROM FAILURE TO FOLLOW THESE PLANS, SPECIFICATIONS AND THE DESIGN INTENT THEY CONVEY, OR FOR PROBLEMS WHICH ARISE FROM OTHERS' FAILURE TO OBTAIN AND/OR FOLLOW THE ENGINEER'S GUIDANCE WITH RESPECT TO ANY ERRORS, OMISSIONS, INCONSISTENCIES AMBIGUITIES OR CONFLICTS WHICH ARE ALLEGED.

CONTRACTOR TO VERIFY ALL DIMENSIONS AND NOTIFY THE ENGINEER OF ANY DISCREPANCIES BEFORE WORK COMMENCES. DO NOT SCALE DRAWINGS.

SCALE: 1:200

**NOT FOR CONSTRUCTION TENDER OR PERMIT**

No.	REVISIONS	BY	DATE
04	RE-ISSUED FOR SITE PLAN CONTROL	K.H.	27 JUN 2025
03	RE-ISSUED FOR SITE PLAN CONTROL	K.H.	02 APR 2024
02	RE-ISSUED FOR SITE PLAN CONTROL	K.H.	13 SEPT 2023
01	ISSUED FOR SITE PLAN CONTROL	K.H.	15 DEC 2022

NOT AUTHENTIC UNLESS SIGNED AND DATED

**LRJ**  
ENGINEERING | INGÉNIERIE  
5430 Canotek Road | Ottawa, ON, K1J 9G2  
www.lrl.ca | (613) 842-3434

CLIENT  
**UNPOISED ARCHITECTURE INC**

DESIGNED BY: K.H. DRAWN BY: K.H. APPROVED BY: M.B.

PROJECT  
**PROPOSED MULTI-UNIT COMMERCIAL DEVELOPMENT 5254 BANK STREET, OTTAWA**

DRAWING TITLE  
**POST-DEVELOPMENT WATERSHED PLAN**

PROJECT NO.  
220536

DATE  
JUNE 2022

**C702**

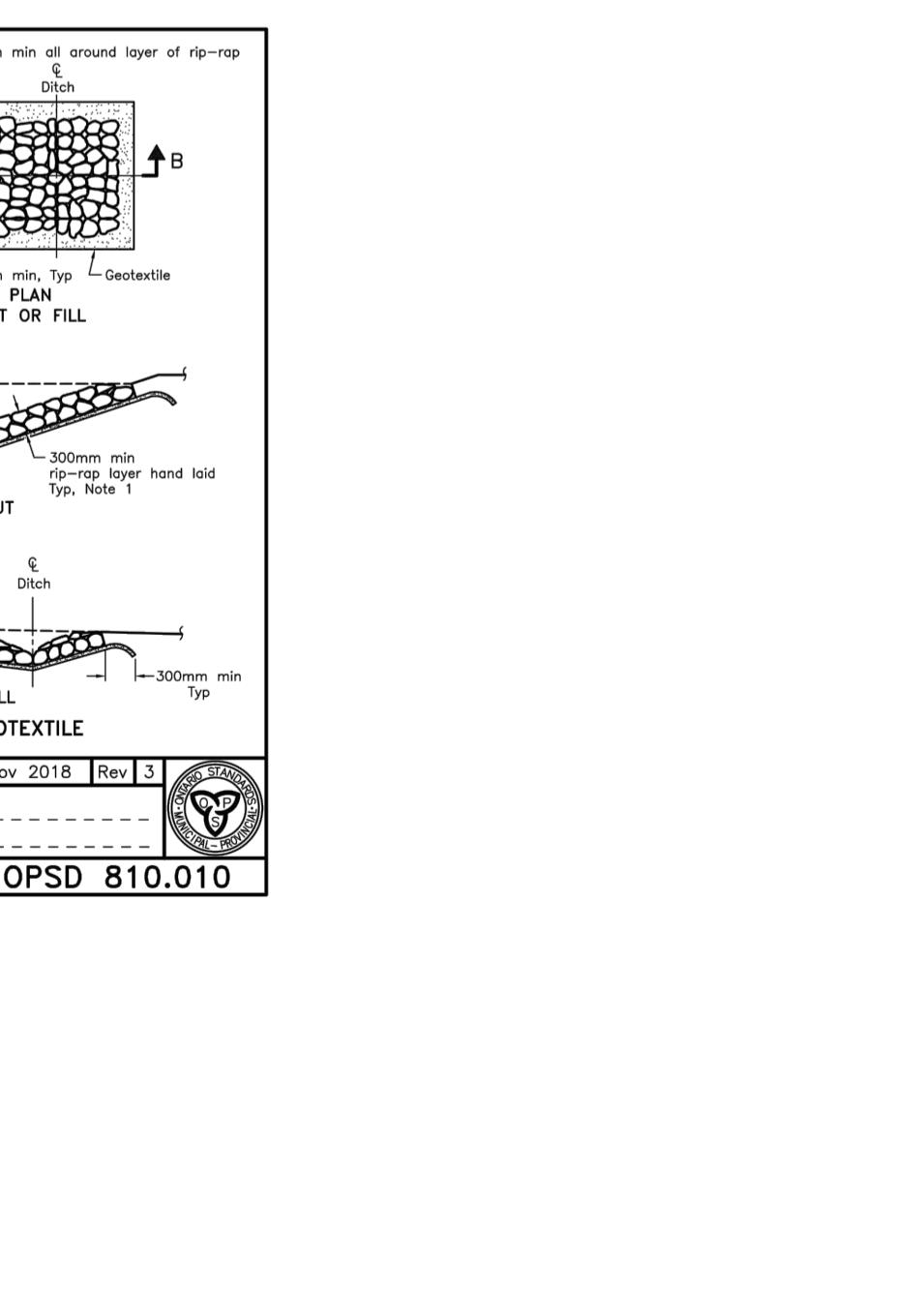
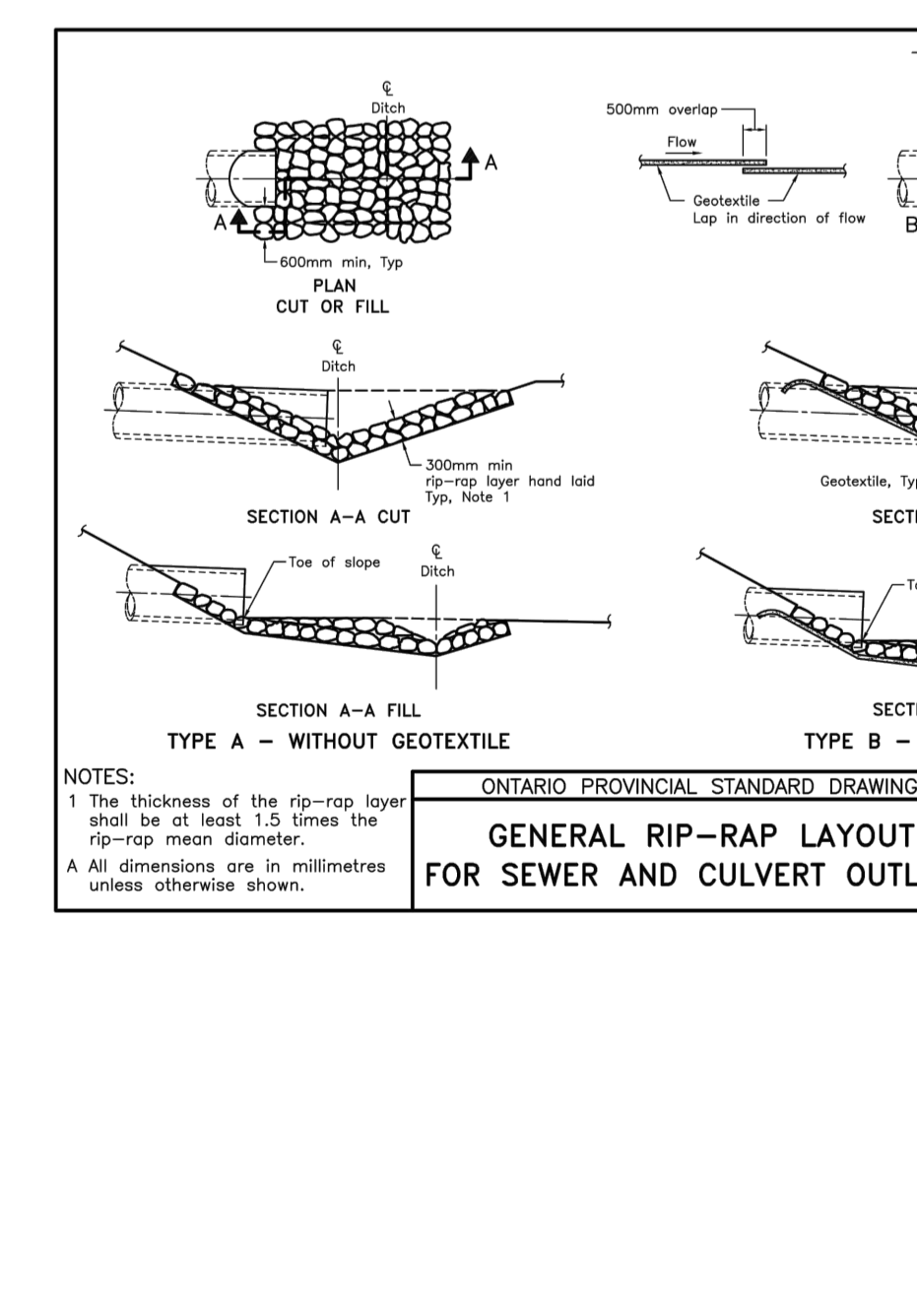
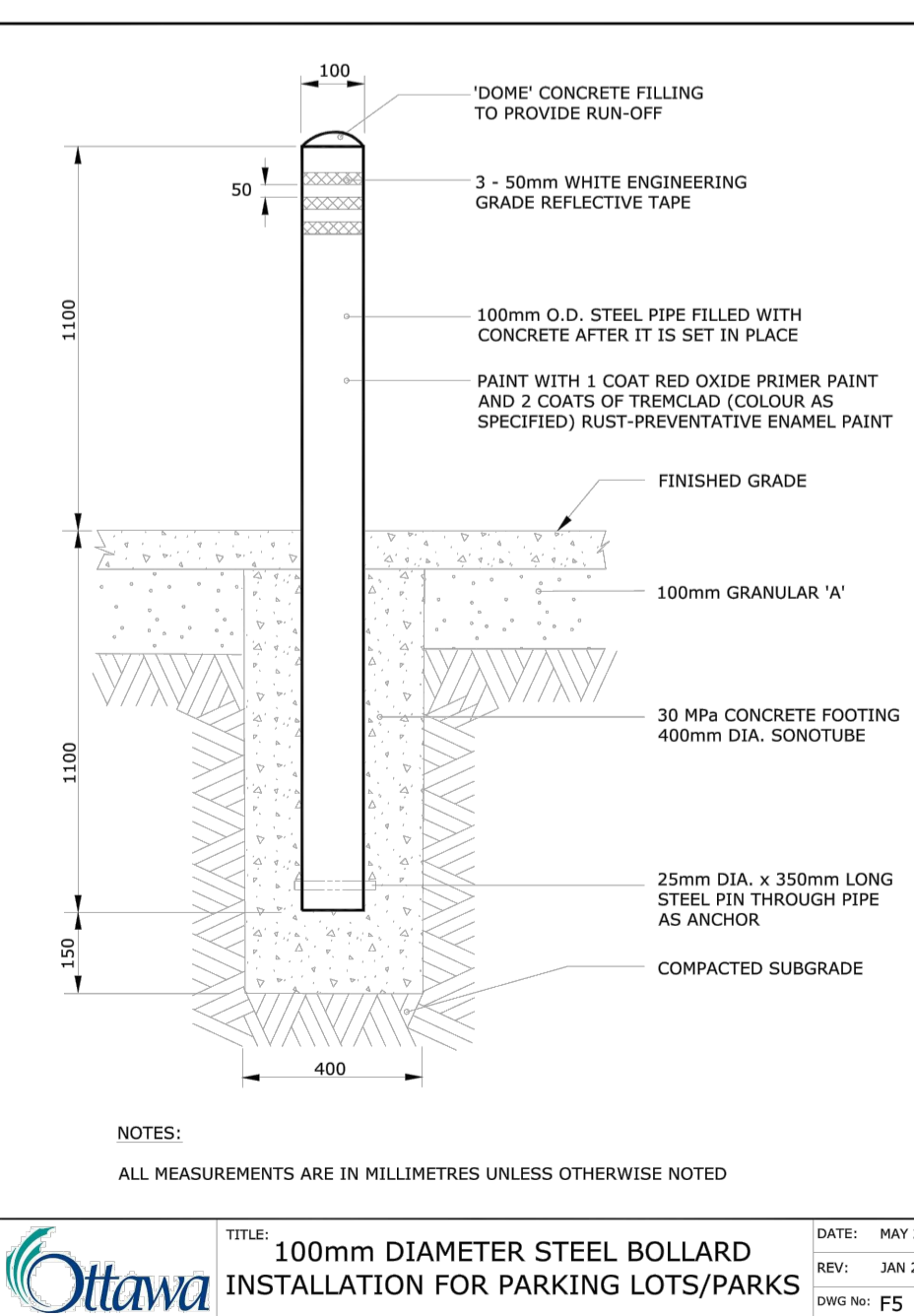
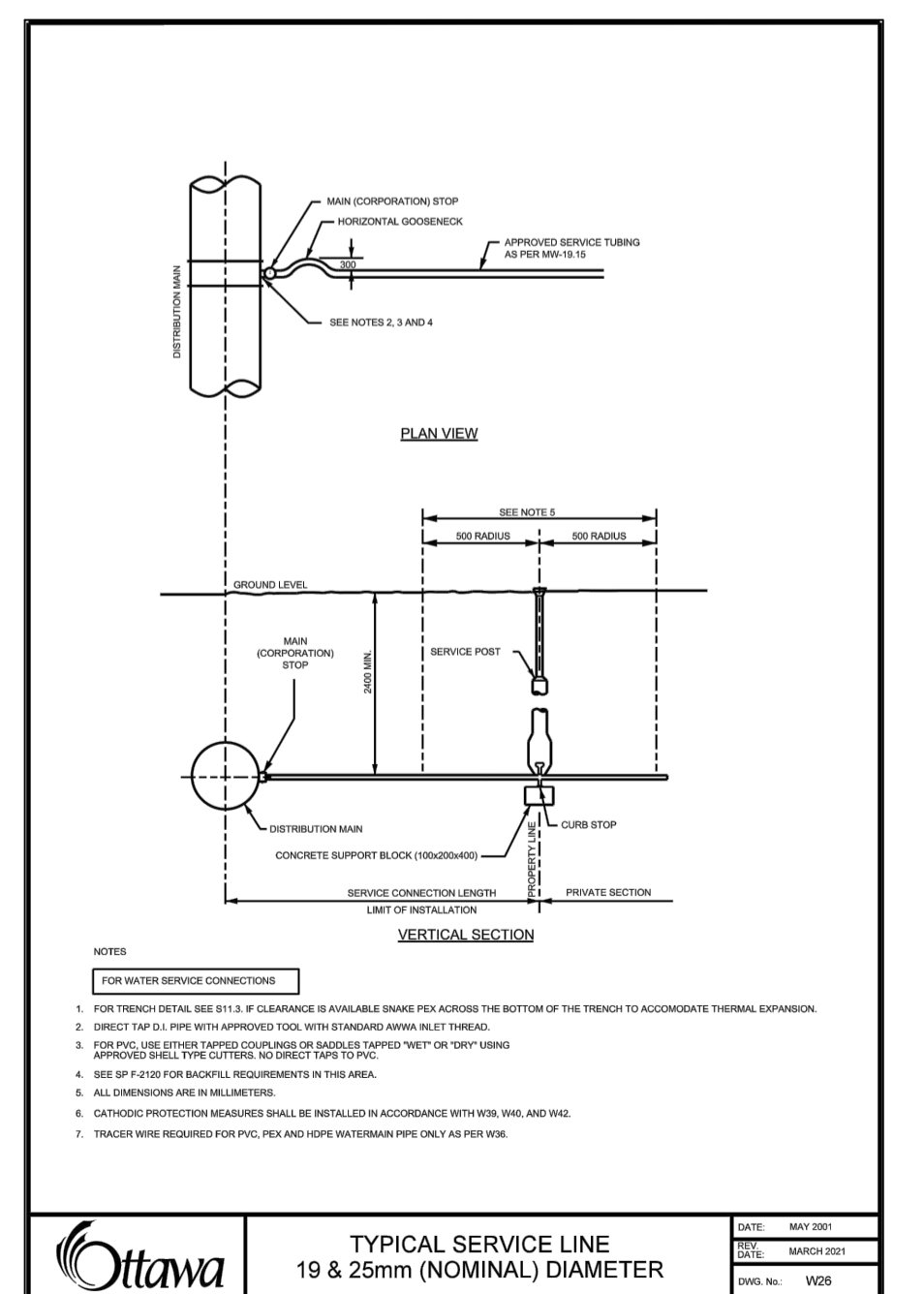
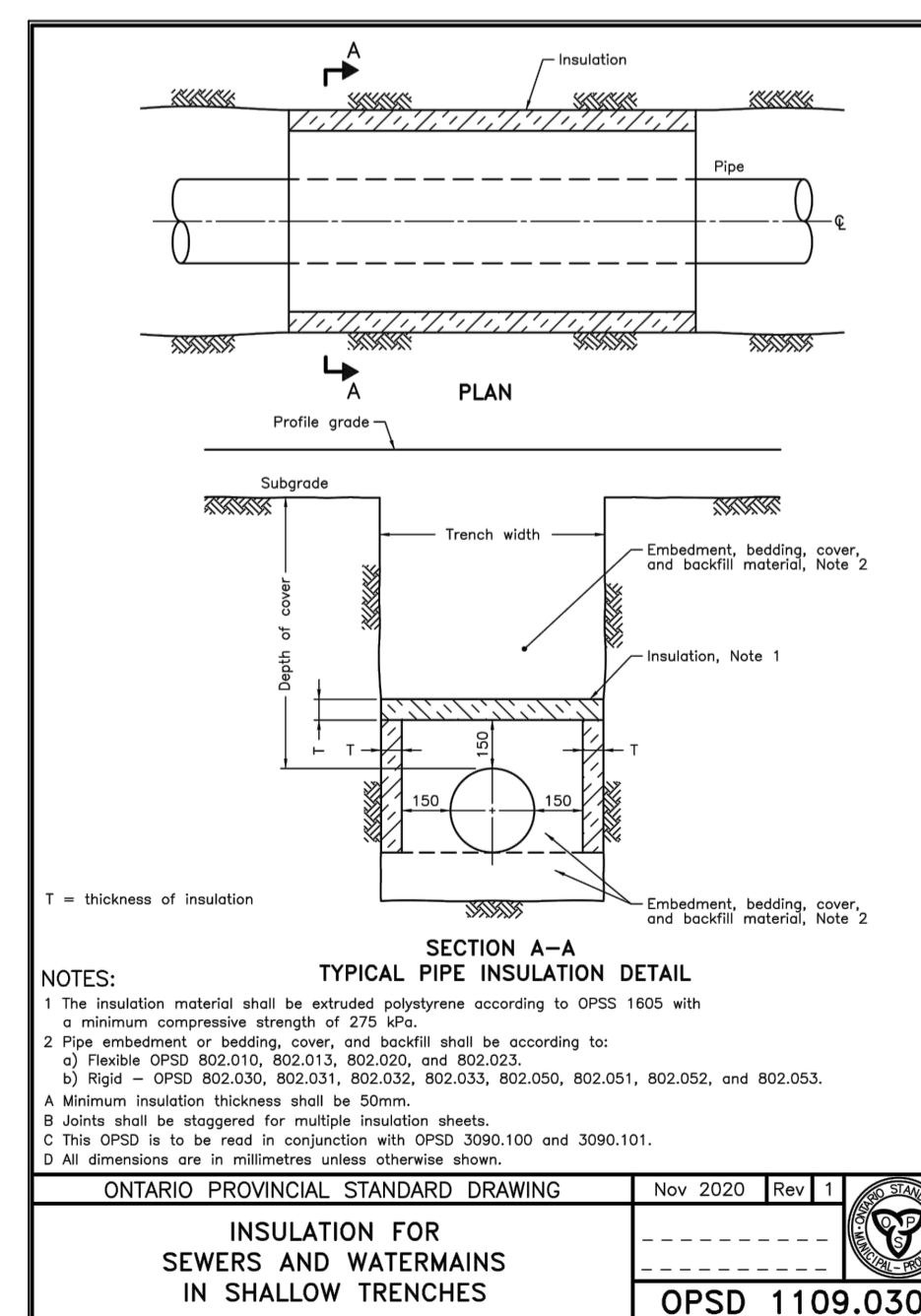
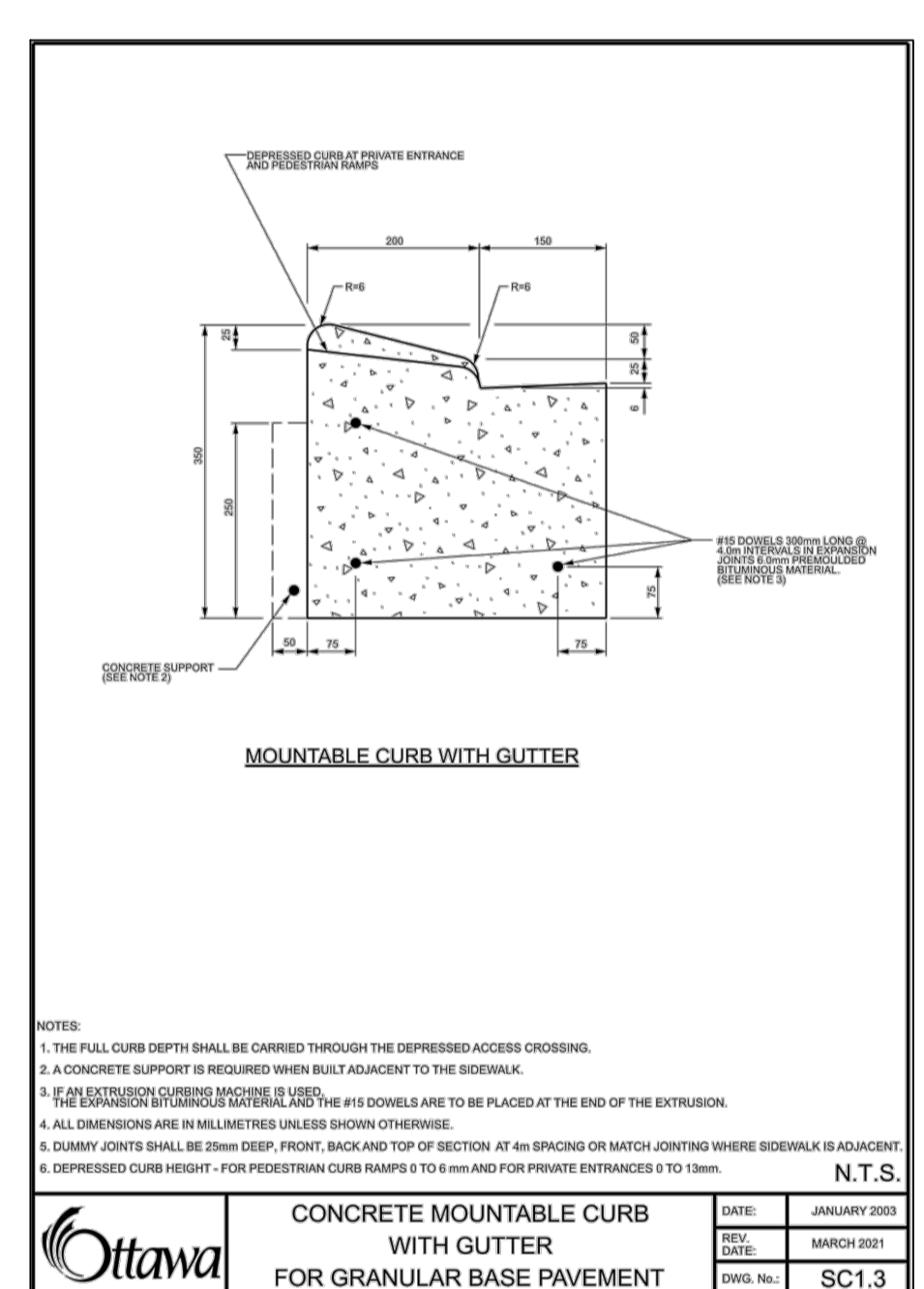
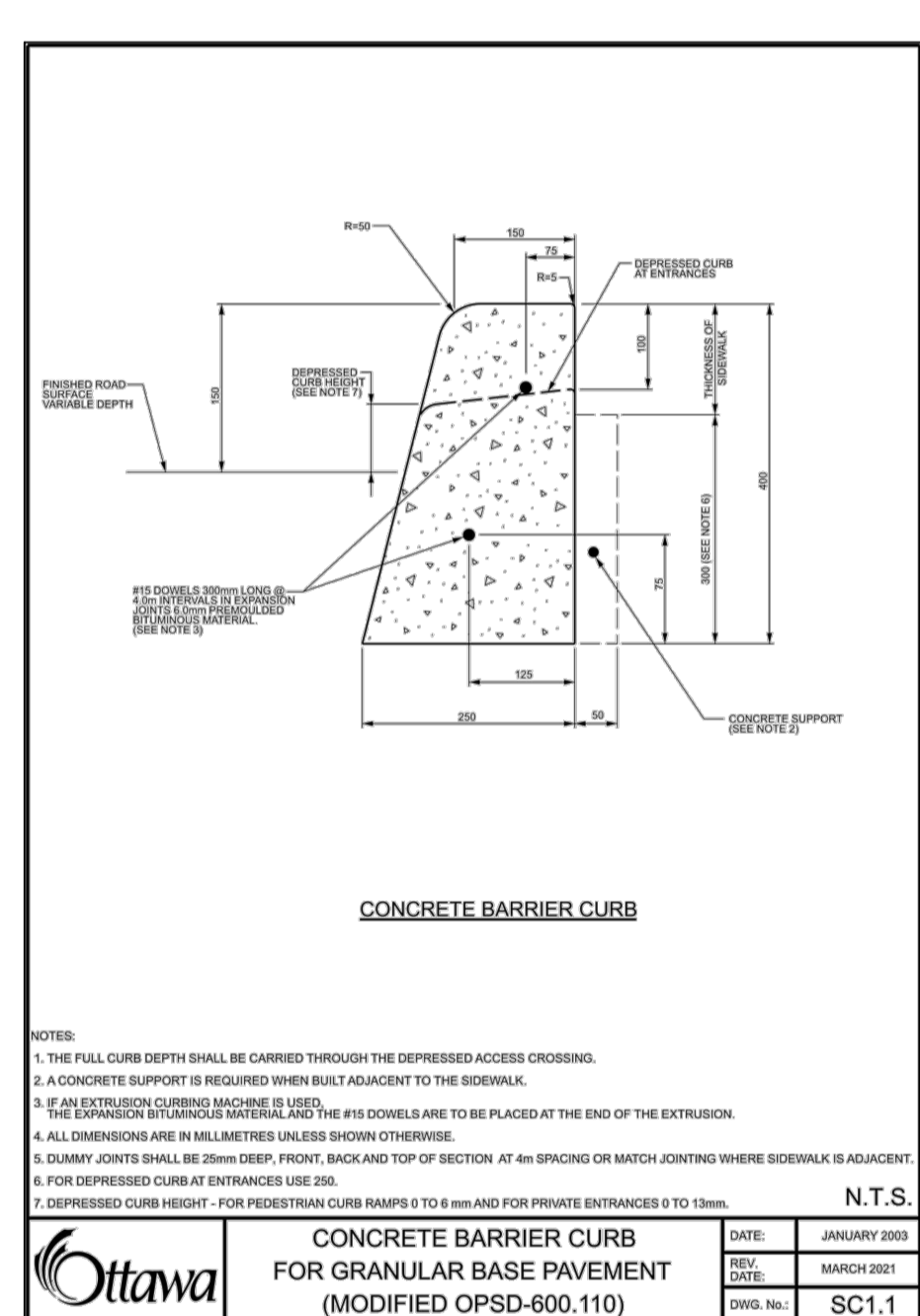
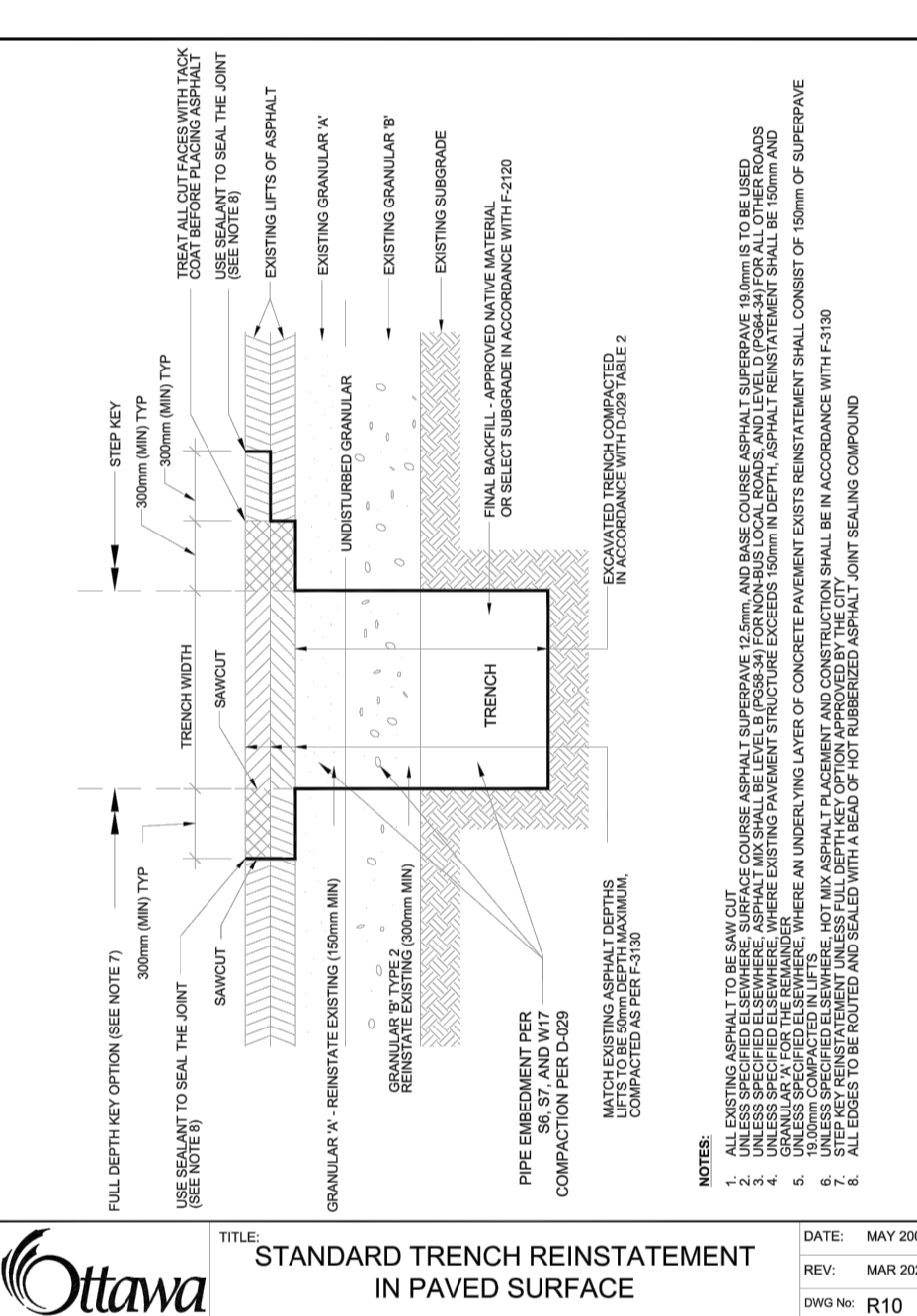
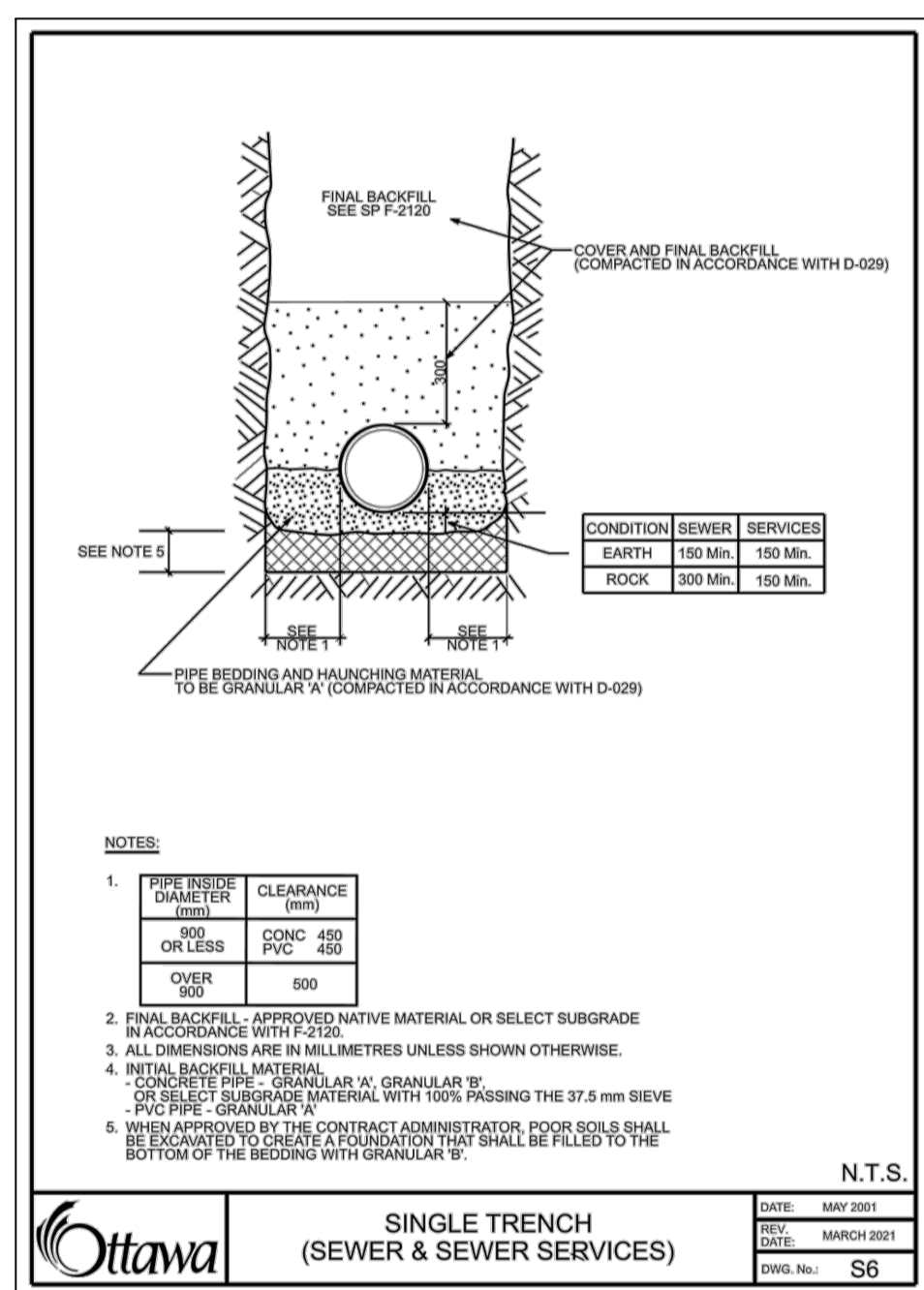
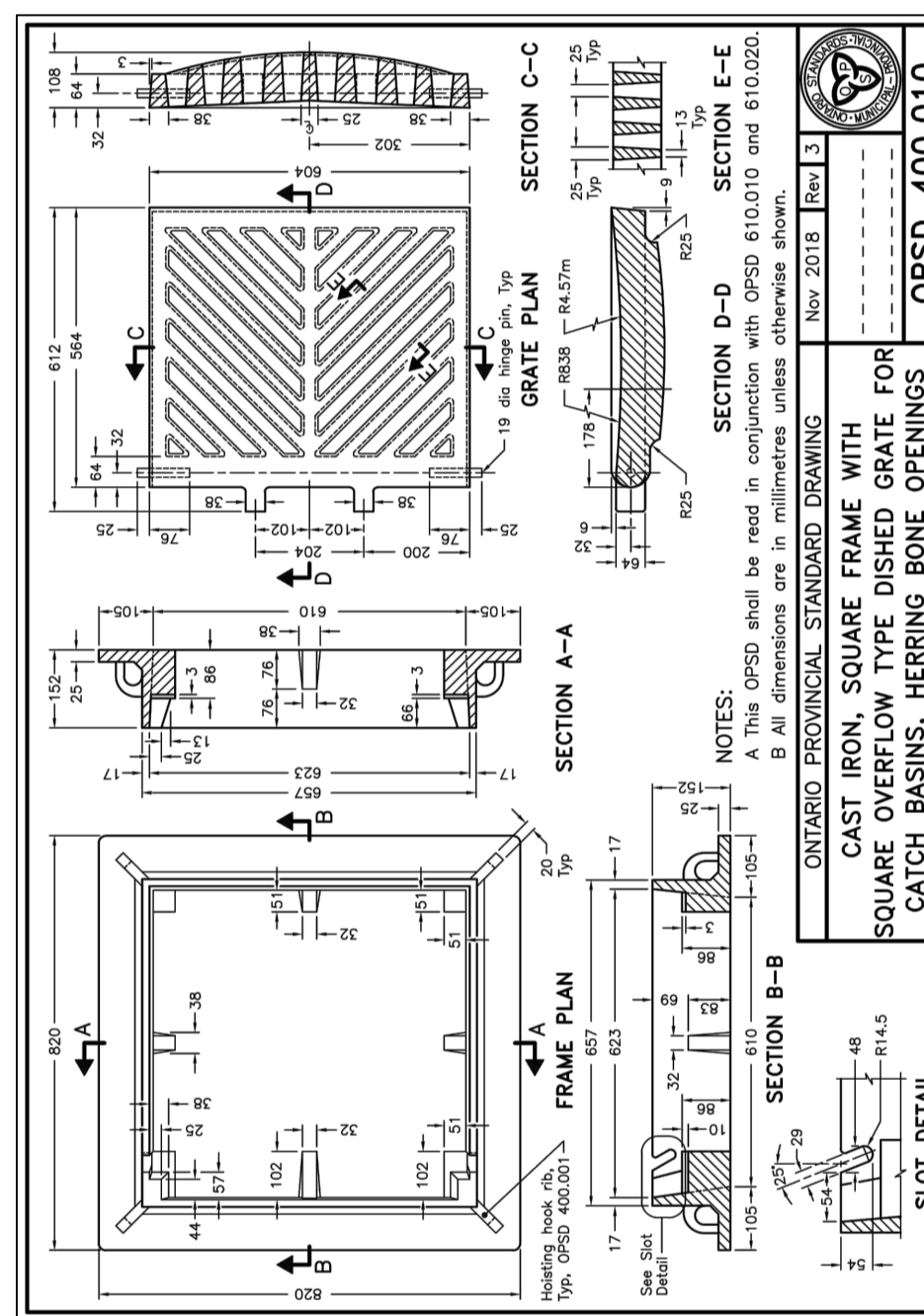
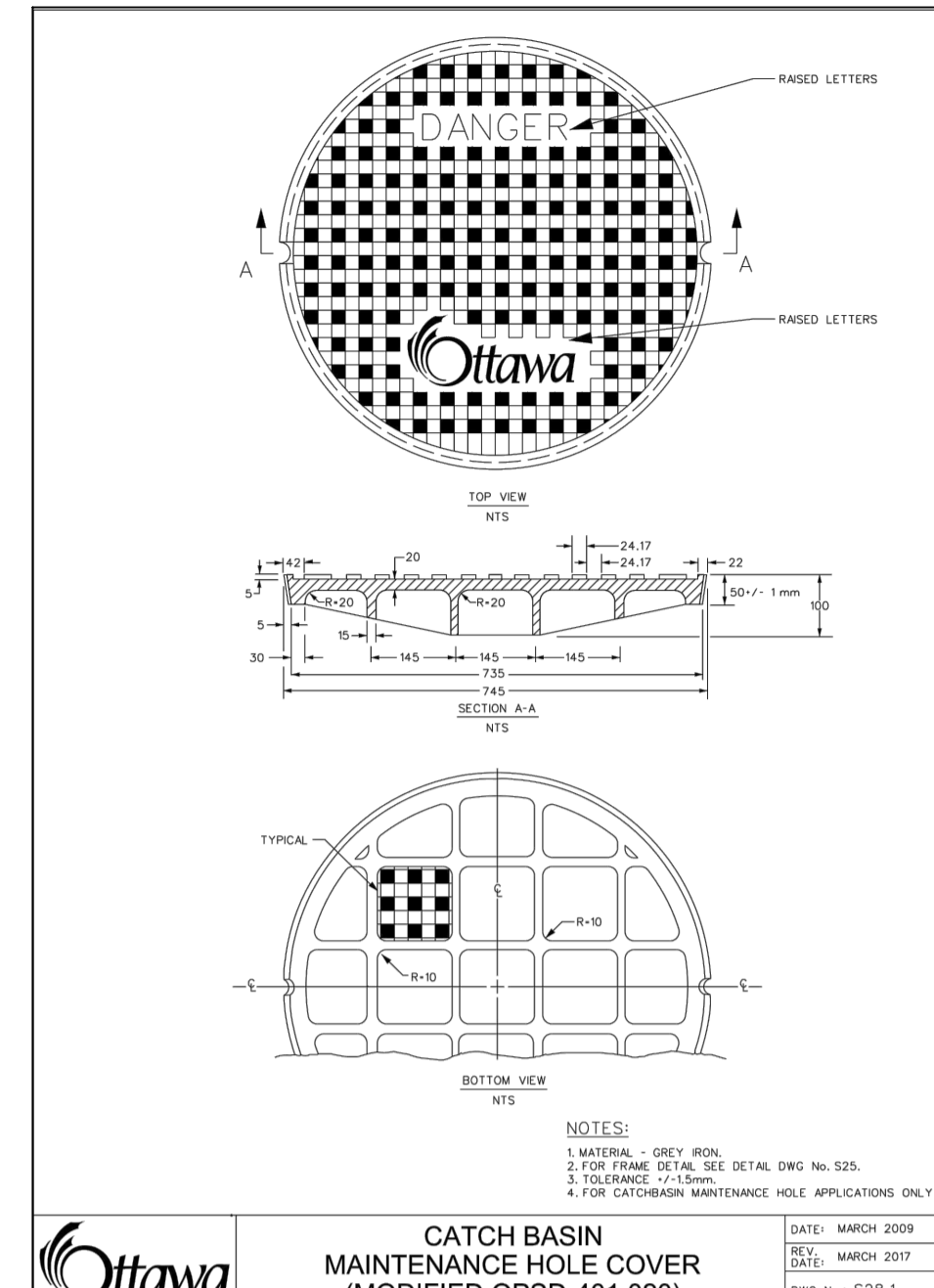
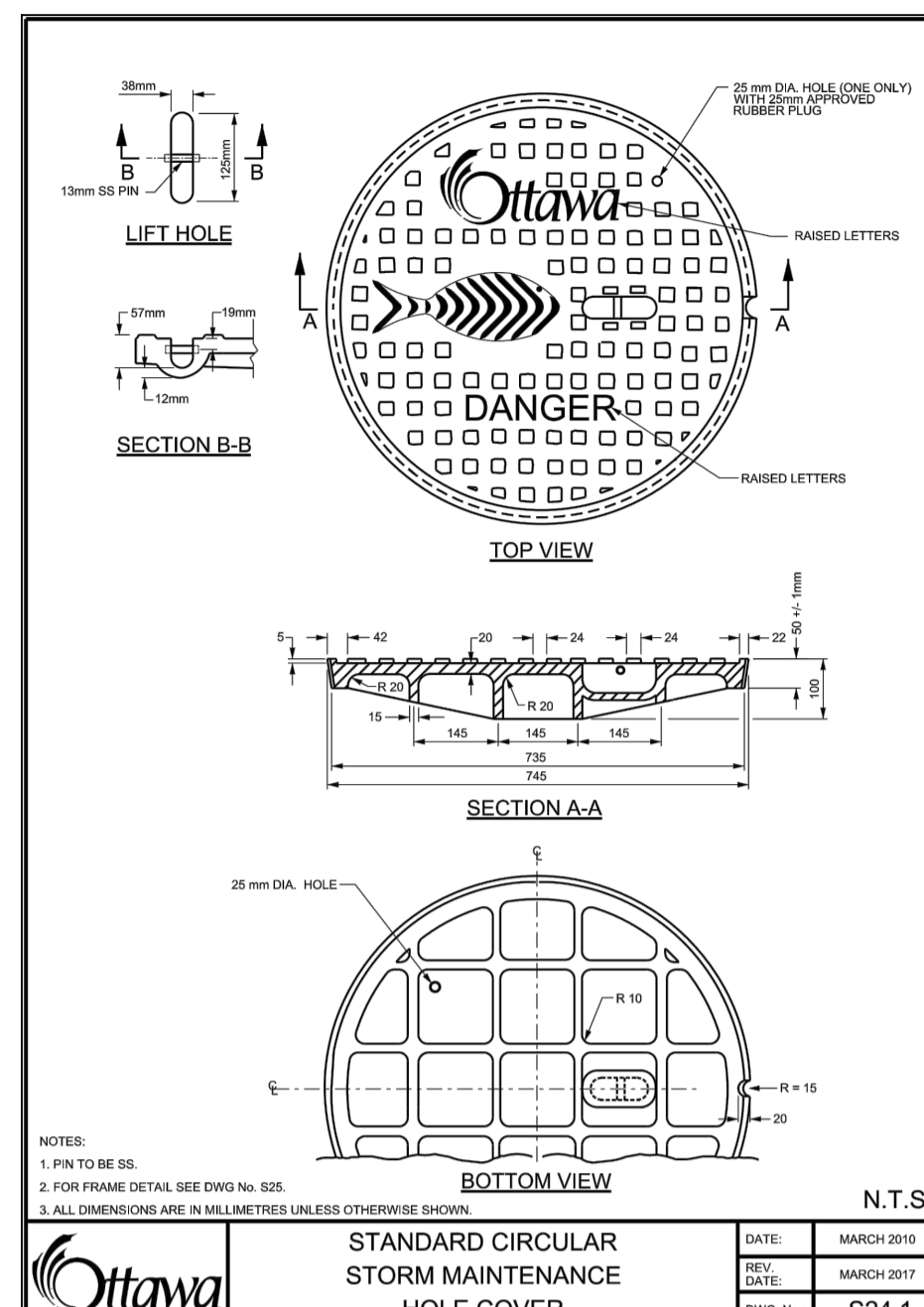
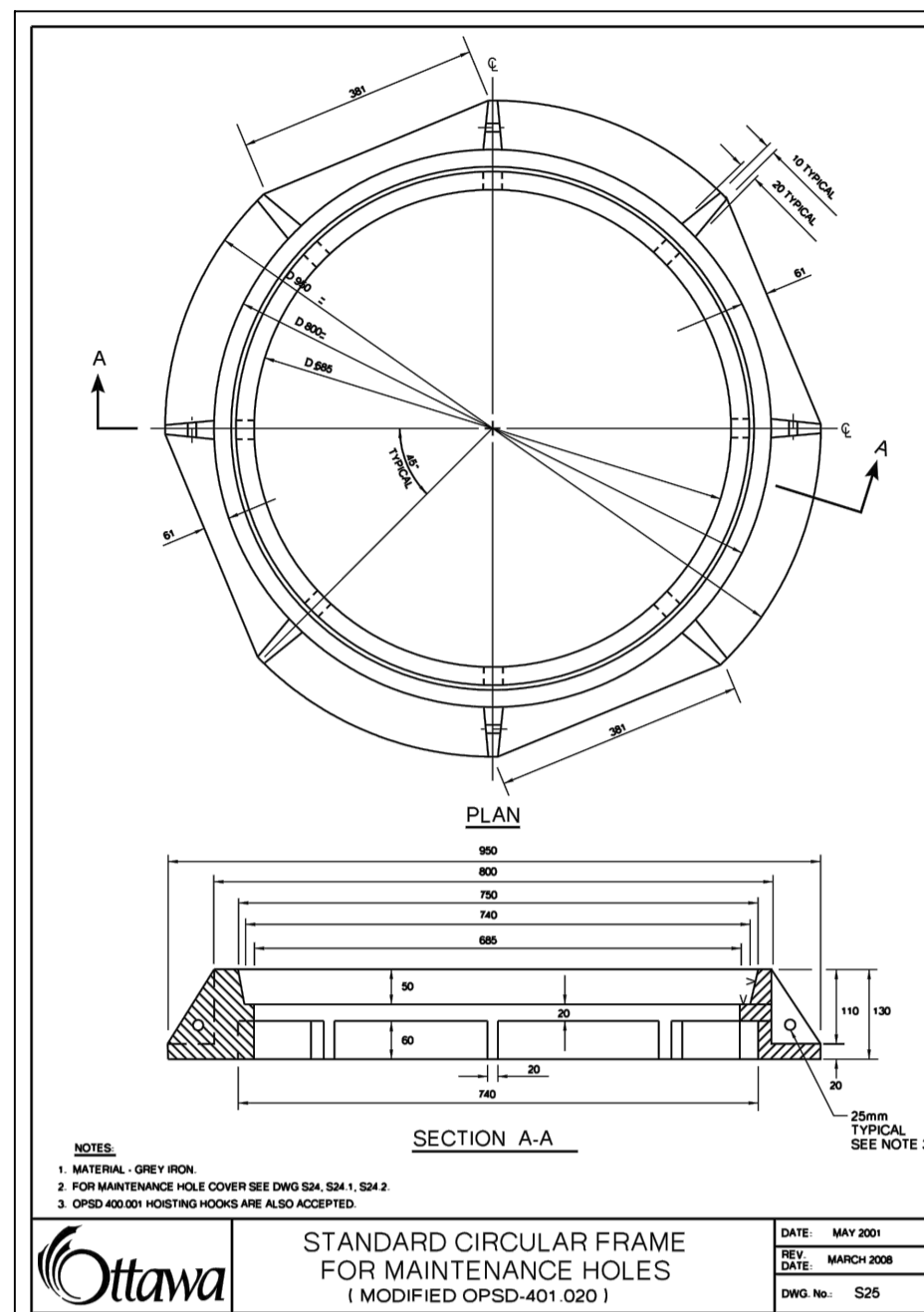
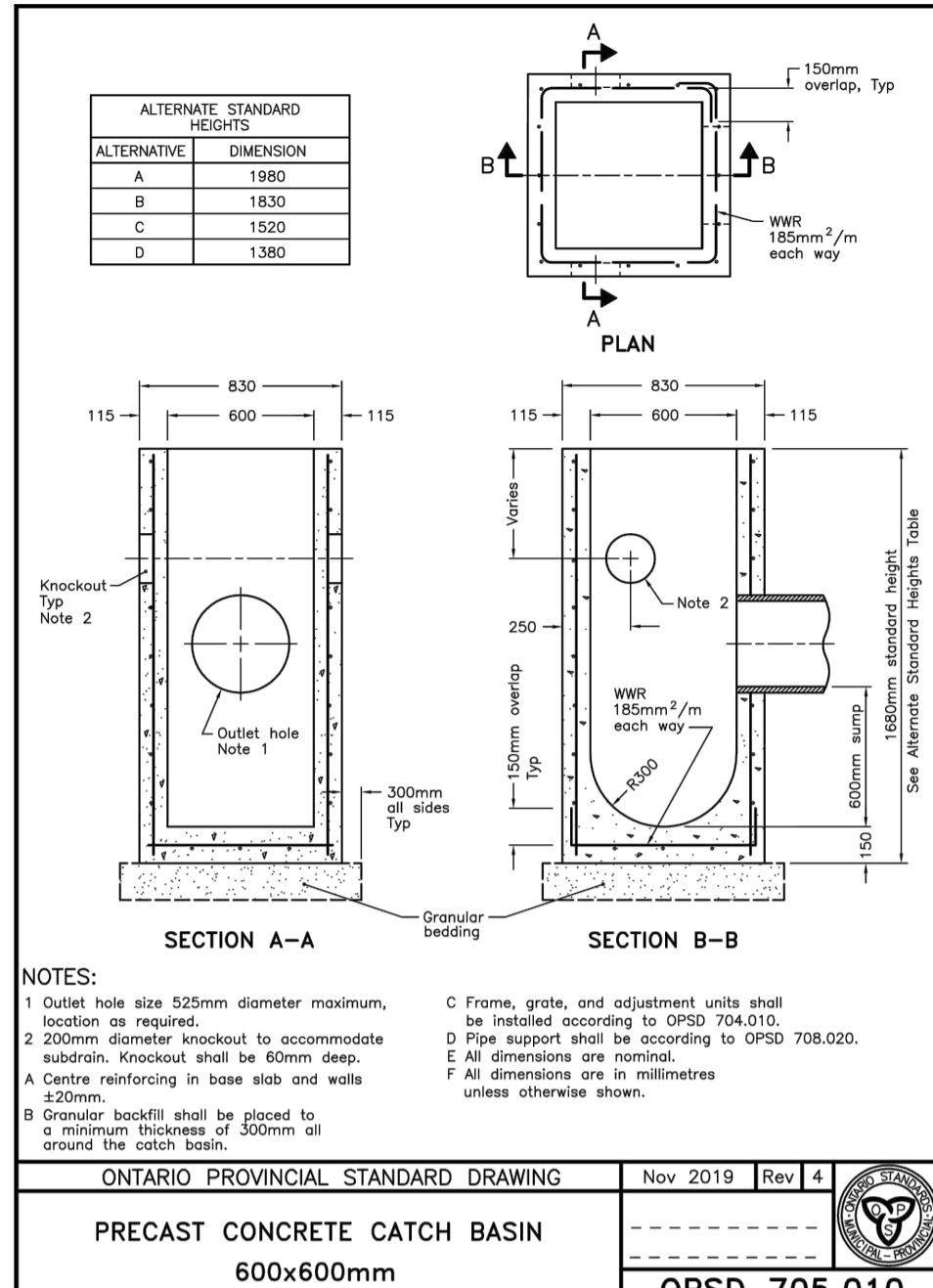
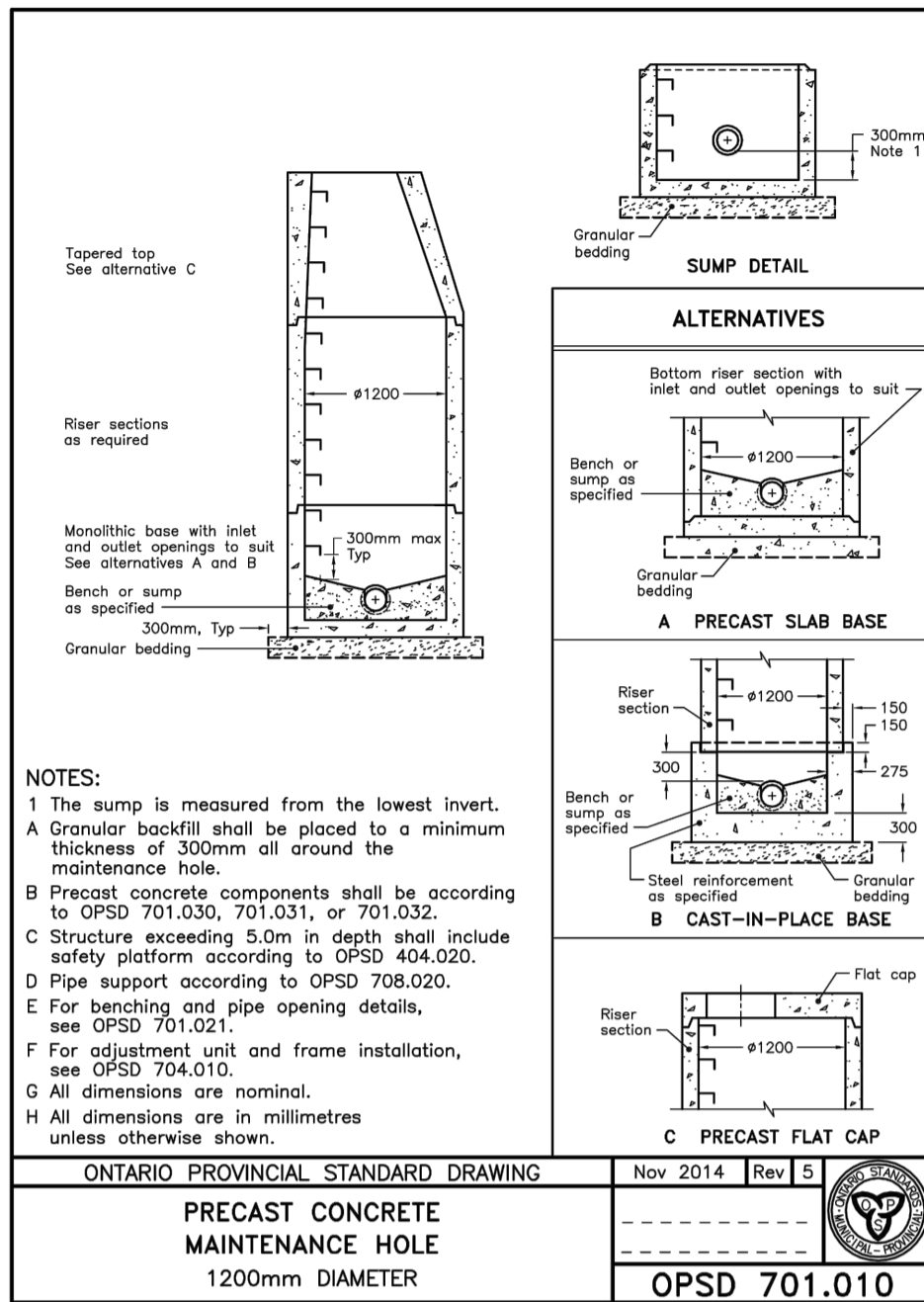

**GENERAL CONDITIONS OF THE CONTRACT FOR CONSTRUCTION ARE PART OF THE CONTRACT DOCUMENTS AND DESCRIBE THE USE AND INTENT OF THE DRAWING. THE CONTRACT DOCUMENTS INCLUDE NOT ONLY THE DRAWINGS, BUT ALSO THE OWNER-CONTRACTOR AGREEMENTS, CONDITIONS OF THE CONTRACT, THE SPECIFICATIONS, ADDENDA, AND MODIFICATIONS ISSUED AFTER EXECUTION OF THE CONTRACT. THESE CONTRACT DOCUMENTS ARE COMPLEMENTARY, AND WHAT IS REQUIRED BY ANY ONE SHALL BE BINDING AS REQUIRED BY ALL. WORK NOT COMPLETELY DELINEATED HEREON SHALL BE CONSTRUCTED OF THE SAME MATERIALS AND DETAILED SIMILARLY AS WORK SHOWN MORE COMPLETELY ELSEWHERE IN THE CONTRACT DOCUMENTS.**

**BY USE OF THE DRAWINGS FOR CONSTRUCTION OF THE PROJECT, THE OWNER CONFIRMS THAT HE HAS REVIEWED AND APPROVED THE DRAWINGS. THE CONTRACTOR CONFIRMS THAT HE HAS VISITED THE SITE, FAMILIARIZED HIMSELF WITH THE LOCAL CONDITIONS, VERIFIED FIELD DIMENSIONS AND CORRELATED THEIR OBSERVATIONS WITH THE REQUIREMENTS OF THE CONTRACT DOCUMENTS.**

**AS INSTRUMENTS OF SERVICE, ALL DRAWINGS, SPECIFICATIONS, CAD FILES OR OTHER ELECTRONIC MEDIA AND COPIES THEREOF FURNISHED BY THE ENGINEER ARE THEIR PROPERTY. THEY ARE TO BE USED ONLY FOR THIS PROJECT AND ARE NOT TO BE USED ON ANY OTHER PROJECT, INCLUDING REPEATS OF THE PROJECT. CHANGES TO THE DRAWINGS MAY ONLY BE MADE BY THE ENGINEER.**

**UNLESS THE REVISION TITLE IS 'ISSUED FOR CONSTRUCTION', THESE DRAWINGS SHALL BE CONSIDERED PRELIMINARY AND SHALL NOT BE USED AS A CONSTRUCTION DOCUMENT.**

**THESE DRAWINGS ILLUSTRATE THE WORK TO BE DONE. THE ENGINEER IS NOT RESPONSIBLE FOR THE MEANS, METHODS, TECHNIQUES, SEQUENCES, AND PROCEDURES USED TO DO THE WORK, OR THE SAFETY ASPECTS OF CONSTRUCTION, AND NOTHING ON THESE DRAWINGS EXPRESSED OR IMPLIED CHANGES THIS CONDITION. CONTRACTOR SHALL DETERMINE ALL CONDITIONS AT THE SITE AND SHALL BE RESPONSIBLE FOR DETERMINING HOW THEY AFFECT THE WORK. SUBMITTAL OF A BID TO PERFORM THIS WORK IS ACKNOWLEDGEMENT OF THE RESPONSIBILITIES AND THAT THEY HAVE BEEN FULLY CONSIDERED IN PLANNING OF THE WORK, AND THE BID PRICE. NO CLAIMS FOR EXTRA CHARGES DUE TO THESE CONDITIONS WILL BE FORTHCOMING.**

**UNAUTHORIZED CHANGES:**

**IN THE EVENT THE CLIENT, THE CLIENT'S CONTRACTORS OR SUBCONTRACTORS, OR ANYONE FOR WHOM THE CLIENT IS LEGALLY LIABLE MAKES OR PERMITS TO BE MADE ANY CHANGES TO ANY PERMITS, PLANS, SPECIFICATIONS OR OTHER CONSTRUCTION DOCUMENTS PREPARED BY ASSOCIATES LTD. (LAL) WITHOUT OBTAINING LAL'S PRIOR WRITTEN CONSENT, THE CLIENT SHALL ASSUME FULL RESPONSIBILITY FOR THE RESULTS OF SUCH CHANGES. THEREFORE THE CLIENT AGREES TO WAIVE ANY CLAIM AGAINST LAL AND TO RELEASE LAL FROM ANY LIABILITY ARISING DIRECTLY OR INDIRECTLY FROM SUCH UNAUTHORIZED CHANGES.**

**IN ADDITION, THE CLIENT AGREES TO THE FULLEST EXTENT PERMITTED BY LAW, TO INDEMNIFY AND HOLD HARMLESS LAL FROM ANY DAMAGES, LIABILITIES OR COSTS, INCLUDING REASONABLE ATTORNEY'S FEES AND COST OF DEFENSE, ARISING FROM SUCH CHANGES.**

**IN ADDITION, THE CLIENT AGREES TO INCLUDE IN ANY CONTRACTS FOR CONSTRUCTION APPROPRIATE LANGUAGE THAT PROHIBITS THE CONTRACTOR OR ANY SUBCONTRACTORS OF ANY TIER FROM MAKING ANY CHANGES OR MODIFICATIONS TO LAL'S CONSTRUCTION DOCUMENTS WITHOUT THE PRIOR WRITTEN APPROVAL OF LAL, AND THAT REQUIRES THE CONTRACTOR TO INDEMNIFY BOTH LAL AND THE CLIENT FROM ANY LIABILITY OR COST ARISING FROM SUCH CHANGES MADE WITHOUT SUCH PROPER AUTHORIZATION.**

**GENERAL NOTES:**

**EXISTING SERVICES AND UTILITIES SHOWN ON THESE DRAWINGS ARE TAKEN FROM THE BEST AVAILABLE RECORDS. THE CLIENT IS LEGALLY LIABLE FOR THE DATE, LOCATION AND DEPTH OF PIPES AND CHECK WITH THE UTILITY COMPANIES BEFORE DIGGING OR CONSTRUCTION WORK.**

**CONTRACTOR IS ADVISED TO COLLECT INFORMATION ON SOIL CONDITIONS BEFORE START OF CONSTRUCTION.**

**THE ENGINEER WAIVES ANY AND ALL RESPONSIBILITY AND LIABILITY FOR PROBLEMS WHICH MAY BE CAUSED BY FAILURE TO FOLLOW THESE PLANS, SPECIFICATIONS AND THE DESIGN INTENT THEY CONVEY, OR FOR PROBLEMS WHICH MAY BE CAUSED BY FAILURE TO OBTAIN AND/OR FOLLOW THE ENGINEER'S GUIDANCE WITH RESPECT TO ANY ERRORS, OMISSIONS, INCONSISTENCIES AMBIGUITIES OR CONFLICTS WHICH ARE ALLEGED.**

**CONTRACTOR TO VERIFY ALL DIMENSIONS AND NOTIFY THE ENGINEER OF ANY DISCREPANCIES BEFORE WORK COMMENCES. DO NOT SCALE DRAWINGS.**

**NOT FOR CONSTRUCTION TENDER OR PERMIT**

No.	REVISIONS	BY	DATE
04	RE-ISSUED FOR SITE PLAN CONTROL	K.H.	27 JUN 2025
03	RE-ISSUED FOR SITE PLAN CONTROL	K.H.	02 APR 2024
02	RE-ISSUED FOR SITE PLAN CONTROL	K.H.	13 SEPT 2023
01	ISSUED FOR SITE PLAN CONTROL	K.H.	15 DEC 2022

**LICENCED PROFESSIONAL ENGINEER**

**M. BASNET**  
100501936

PROVINCE OF ONTARIO

NOT AUTHENTIC UNLESS SIGNED AND DATED

**LRJ**  
ENGINEERING | INGENIERIE  
5430 Canotek Road | Ottawa, ON, K1J 9G2  
www.lrl.ca | (613) 842-3434

CLIENT: UNPOISED ARCHITECTURE INC

DESIGNED BY: K.H. DRAWN BY: K.H. APPROVED BY: M.B.

PROJECT: PROPOSED MULTI-UNIT COMMERCIAL DEVELOPMENT 5254 BANK STREET, OTTAWA

DRAWING TITLE: CONSTRUCTION DETAIL PLAN

PROJECT NO: 220536  
DATE: JUNE 2022

**C901**

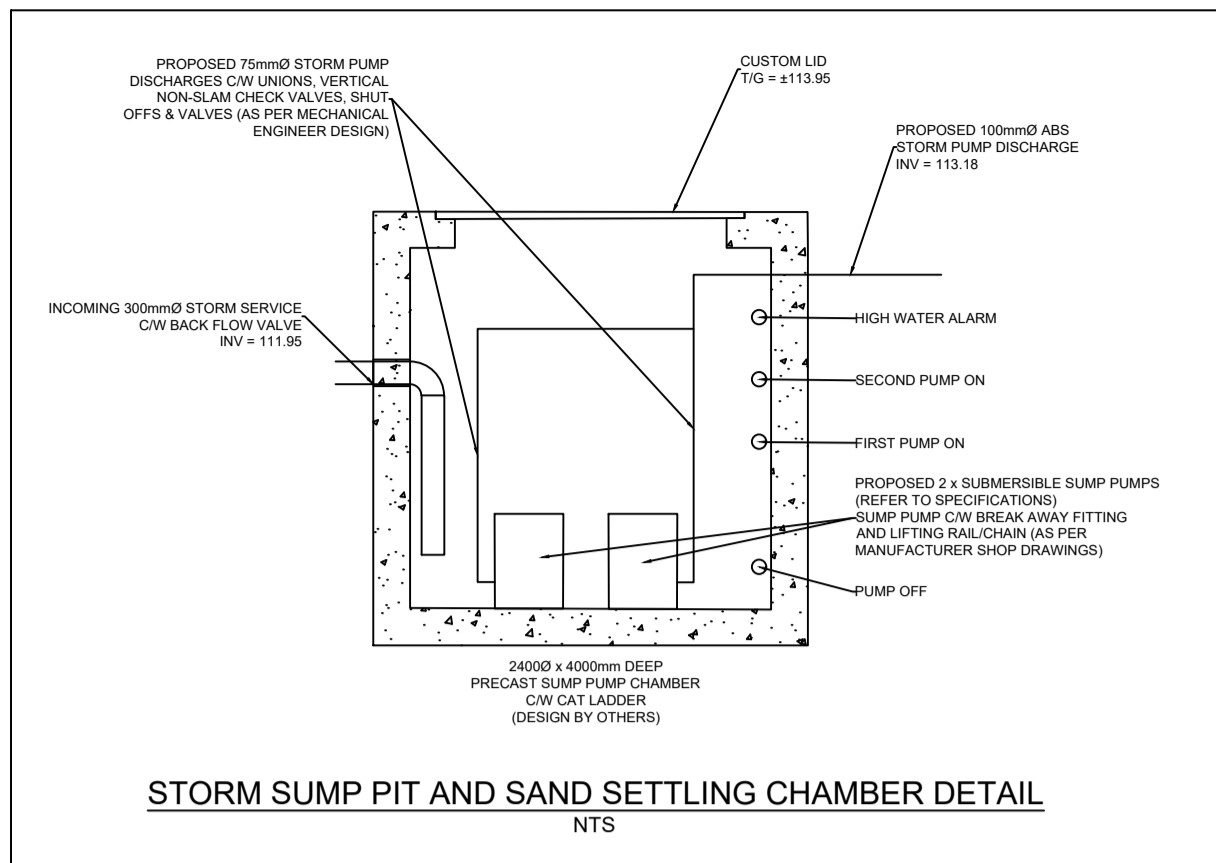

**Duplex Submersible Sump Pumps**

**1.0 PRODUCTS**

**2.01 MATERIALS**  
Materials and products in accordance with Sustainable Requirements and in compliance with the latest CSA Standard C22.2 No. 108-1

**2.02 SUMP PUMP SUBMERSIBLE**  
Capacity – each pump to deliver 90 USGPM @ 40' head  
Motor – VTR20H-S3 - Myers Sewage Pump 2HP, 575/360, 3.8FLA  
Construction and Accessories – SRA-200 - Pentair Lift-Out Rail Assembly 2'x2' for 3/4" Rail; TRS-75 - Pentair Upper Rail Galvanized Support for 3/4" x 40 Rail; CP-75-2 - Pentair Galvanized Chain Package 10ft w. Lifting Ball & Shackles; mounting base, check valve, guide plate, fasteners and O-rings  
Controls – DEIX56 - CamMech Duplex Control Panel 2HP, 575/360, 3.8FLA, EEMAC1, Relay & Block  
Additional Fastenings – SC20-EO - Pentair 20R Level Control, Externally Weighted N/O; CSB-4SS - Pentair SST Float Bracket for 4" S' Level Controls

**2.0 INSTALLATION**

Comply with manufacturer's written recommendations and specifications, including product technical bulletins, handling, storage and installation instructions and data sheet  
Make piping and electrical connections to pump and motor assembly and controls as indicated  
Confirm source of electrical power and its routing for the pumps; engage certified electrical tech to provide power to the pumps and controls  
Ensure pump and motor assembly do not support piping  
Site test/inspection - Check power supply and starter protective devices  
Start-up, check for proper and safe operation  
Check settings and operation of hand-off-auto selector switch, operating, safety and limit controls, audible and visual alarms, over-temperature and other protective devices  
Commissioning – after full installation and start-up commission pumps and pump assembly along with its controls ensuring it meets the spec, witnessed by the engineer's representative, and submit a full commissioning report signifying the entire installation  
Provide operator training to the owner's representative as required

**Advantages by Design**

Model	Capacity	Head	Power
SR-100	10 GPM	10 FT	1/2 HP
SR-150	15 GPM	15 FT	3/4 HP
SR-200	20 GPM	20 FT	1 HP
SR-250	25 GPM	25 FT	1.5 HP
SR-300	30 GPM	30 FT	2 HP
SR-350	35 GPM	35 FT	2.5 HP
SR-400	40 GPM	40 FT	3 HP
SR-450	45 GPM	45 FT	3.5 HP
SR-500	50 GPM	50 FT	4 HP
SR-550	55 GPM	55 FT	4.5 HP
SR-600	60 GPM	60 FT	5 HP
SR-650	65 GPM	65 FT	5.5 HP
SR-700	70 GPM	70 FT	6 HP
SR-750	75 GPM	75 FT	6.5 HP
SR-800	80 GPM	80 FT	7 HP
SR-850	85 GPM	85 FT	7.5 HP
SR-900	90 GPM	90 FT	8 HP
SR-950	95 GPM	95 FT	8.5 HP
SR-1000	100 GPM	100 FT	9 HP

**PENTAIR MYERS**

**Typical Installation CSB4-SS and CSB5-SS Float Mounting Bracket**

**25193A100**

QTY	DESCRIPTION	UNIT
1	07-59-978-9000 3/16" GALV. CHAIN 10 FT. LONG	
1	07-59-972-9000 3/16" GALV. CHAIN 6 FT. LONG	
1	82417A001 CLEVIS, 1/4" REC. D.	

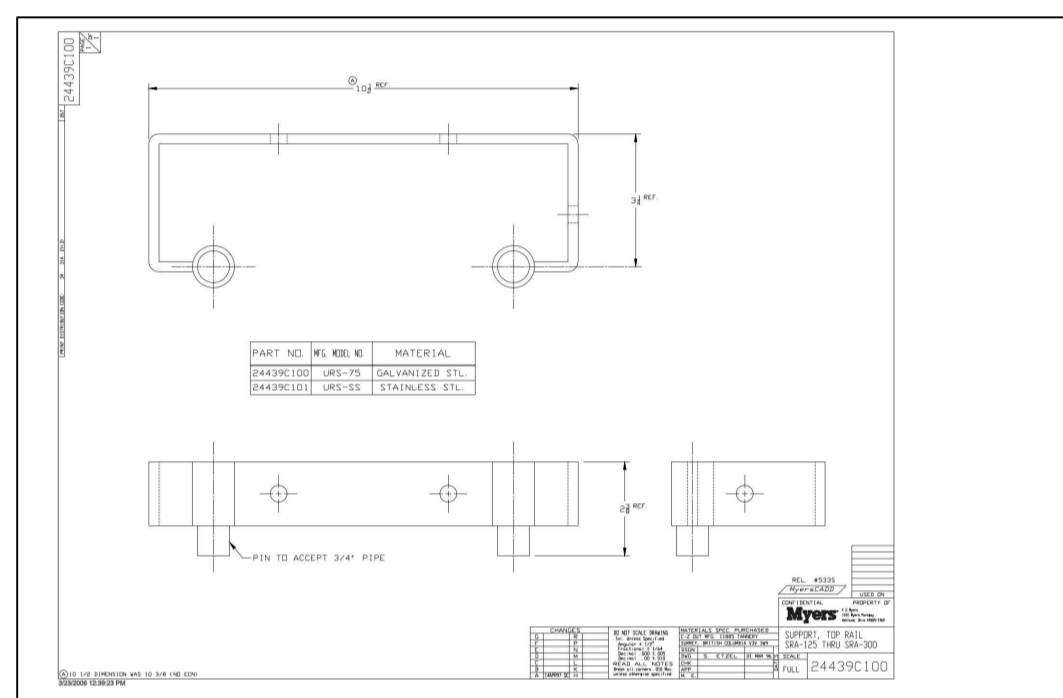

**USE AND INTERPRETATION OF DRAWINGS**

GENERAL CONDITIONS OF THE CONTRACT FOR CONSTRUCTION ARE PART OF THE CONTRACT DOCUMENTS AND DESCRIBE THE USE AND INTENT OF THE DRAWING. THE CONTRACT DOCUMENTS INCLUDE NOT ONLY THE DRAWINGS, BUT ALSO THE OWNER-CONTRACTOR AGREEMENTS, CONDITIONS OF THE CONTRACT, THE SPECIFICATIONS, ADDENDA, AND MODIFICATIONS ISSUED AFTER EXECUTION OF THE CONTRACT. THESE CONTRACT DOCUMENTS ARE COMPLEMENTARY, AND WHAT IS REQUIRED BY ANY ONE SHALL BE BINDING AS IF REQUIRED BY ALL. WORK NOT COMPLETELY DELINEATED HEREON SHALL BE CONSTRUCTED OF THE SAME MATERIALS AND DETAIL AS SHOWN MORE COMPLETELY ELSEWHERE IN THE CONTRACT DOCUMENTS.

BY USE OF THE DRAWINGS FOR CONSTRUCTION OF THE PROJECT, THE OWNER CONFIRMS THAT HE HAS REVIEWED AND APPROVED THE DRAWINGS. THE CONTRACTOR CONFIRMS THAT THEY HAVE VISITED THE SITE, FAMILIARIZED THEMSELVES WITH THE LOCAL CONDITIONS, VERIFIED FIELD DIMENSIONS AND CORRELATED THEIR OBSERVATIONS WITH THE REQUIREMENTS OF THE CONTRACT DOCUMENTS.

AS INSTRUMENTS OF SERVICE, ALL DRAWINGS, SPECIFICATIONS, CAD FILES OR OTHER ELECTRONIC MEDIA AND COPIES THEREOF FURNISHED BY THE ENGINEER ARE THEIR PROPERTY. THEY ARE TO BE USED ONLY FOR THIS PROJECT AND ARE NOT TO BE USED ON ANY OTHER PROJECT, INCLUDING REPEATS OF THE PROJECT. CHANGES TO THE DRAWINGS MAY ONLY BE MADE BY THE ENGINEER.

UNLESS THE REVISION TITLE IS "ISSUED FOR CONSTRUCTION", THESE DRAWINGS SHALL BE CONSIDERED PRELIMINARY AND SHALL NOT BE USED AS A CONSTRUCTION DOCUMENT.

THESE DRAWINGS ILLUSTRATE THE WORK TO BE DONE. THE ENGINEER IS NOT RESPONSIBLE FOR THE MEANS, METHODS, TECHNIQUES, SEQUENCES, AND PROCEDURES USED TO DO THE WORK, OR THE SAFETY ASPECTS OF CONSTRUCTION, AND NOTHING ON THESE DRAWINGS EXPRESSED OR IMPLIED CHANGES THIS CONDITION. CONTRACTOR SHALL DETERMINE ALL CONDITIONS AT THE SITE AND SHALL BE RESPONSIBLE FOR DETERMINING HOW THEY AFFECT THE WORK. SUBMITTAL OF A BID TO PERFORM THIS WORK IS ACKNOWLEDGEMENT OF THE RESPONSIBILITIES AND THAT THEY HAVE BEEN FULLY CONSIDERED IN PLANNING OF THE WORK, AND THE BID PRICE. NO CLAIMS FOR EXTRA CHARGES DUE TO THESE CONDITIONS WILL BE FORTHCOMING.

**UNAUTHORIZED CHANGES:**

IN THE EVENT THE CLIENT, THE CLIENT'S CONTRACTORS OR SUBCONTRACTORS, OR ANYONE FOR WHOM THE CLIENT IS LEGALLY LIABLE MAKES OR PERMITS TO BE MADE ANY CHANGES TO ANY REPORTS, PLANS, SPECIFICATIONS OR OTHER CONSTRUCTION DOCUMENTS PREPARED BY LRL ASSOCIATES LTD (LRL) WITHOUT OBTAINING LRL'S PRIOR WRITTEN CONSENT, THE CLIENT SHALL ASSUME FULL RESPONSIBILITY FOR THE RESULTS OF SUCH CHANGES. THEREFORE THE CLIENT AGREES TO WAIVE ANY CLAIM AGAINST LRL AND TO RELEASE LRL FROM ANY LIABILITY ARISING DIRECTLY OR INDIRECTLY FROM SUCH UNAUTHORIZED CHANGES.

IN ADDITION, THE CLIENT AGREES TO THE FULLEST EXTENT PERMITTED BY LAW, TO INDEMNIFY AND HOLD HARMLESS LRL FROM ANY DAMAGES, LIABILITIES OR COSTS, INCLUDING REASONABLE ATTORNEY'S FEES AND COST OF DEFENSE, ARISING FROM SUCH CHANGES.

IN ADDITION, THE CLIENT AGREES TO INCLUDE IN ANY CONTRACTS FOR CONSTRUCTION APPROPRIATE LANGUAGE THAT PROHIBITS THE CONTRACTOR OR ANY SUBCONTRACTORS OF ANY TIER FROM MAKING ANY CHANGES OR MODIFICATIONS TO LRL'S CONSTRUCTION DOCUMENTS WITHOUT THE PRIOR WRITTEN APPROVAL OF LRL, AND THAT REQUIRES THE CONTRACTOR TO INDEMNIFY BOTH LRL AND THE CLIENT FROM ANY LIABILITY OR COST ARISING FROM SUCH CHANGES MADE WITHOUT SUCH PROPER AUTHORIZATION.

**GENERAL NOTES:**

EXISTING SERVICES AND UTILITIES SHOWN ON THESE DRAWINGS ARE TAKEN FROM THE BEST AVAILABLE RECORDS, BUT MAY NOT BE COMPLETE OR TO DATE. CONTRACTOR SHALL VERIFY IN FIELD FOR LOCATION AND ELEVATION OF PIPES AND CHECK WITH THE UTILITY COMPANIES BEFORE DIGGING OR PERFORMING WORK.

CONTRACTOR IS ADVISED TO COLLECT INFORMATION ON SOIL CONDITIONS BEFORE START OF CONSTRUCTION.

THE ENGINEER WAIVES ANY AND ALL RESPONSIBILITY AND LIABILITY FOR PROBLEMS WHICH ARISE FROM FAILURE TO FOLLOW THESE PLANS, SPECIFICATIONS AND THE DESIGN INTENT THEY CONVEY, OR FOR PROBLEMS WHICH ARISE FROM OTHERS' FAILURE TO OBTAIN AND/OR FOLLOW THE ENGINEER'S GUIDANCE WITH RESPECT TO ANY ERRORS, OMISSIONS, INCONSISTENCIES AMBIGUITIES OR CONFLICTS WHICH ARE ALLEGED.

CONTRACTOR TO VERIFY ALL DIMENSIONS AND NOTIFY THE ENGINEER OF ANY DISCREPANCIES BEFORE WORK COMMENCES. DO NOT SCALE DRAWINGS.

**NOT FOR CONSTRUCTION TENDER OR PERMIT**

No.	REVISIONS	BY	DATE
04	RE-ISSUED FOR SITE PLAN CONTROL	K.H.	27 JUN 2025
03	RE-ISSUED FOR SITE PLAN CONTROL	K.H.	02 APR 2024
02	RE-ISSUED FOR SITE PLAN CONTROL	K.H.	13 SEPT 2023
01	ISSUED FOR SITE PLAN CONTROL	K.H.	15 DEC 2022

NOT AUTHENTIC UNLESS SIGNED AND DATED

**LRJ**  
ENGINEERING | INGENIERIE  
5430 Canotek Road | Ottawa, ON, K1J 9G2  
www.lrl.ca | (613) 842-3434

CLIENT  
**UNPOISED ARCHITECTURE INC**

DESIGNED BY: **K.H.** DRAWN BY: **K.H.** APPROVED BY: **M.B.**

PROJECT  
**PROPOSED MULTI-UNIT COMMERCIAL DEVELOPMENT 5254 BANK STREET, OTTAWA**

DRAWING TITLE  
**CONSTRUCTION DETAIL PLAN**

PROJECT NO.  
**220536**

DATE  
**JUNE 2022**

**C902**

## **DRAWINGS/FIGURES**

**Proposed Site Plan  
Legal Survey**



PART OF LOT 28  
CONCESSION 4 (RIDEAU FRONT)  
GEOGRAPHIC TOWNSHIP OF GLOUCESTER  
CITY OF OTTAWA

FARLEY, SMITH & DENIS SURVEYING LTD. 2019

Scale 1: 200

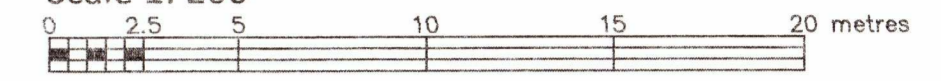

Metric Note

Distances and coordinates on this plan are in metres and can be converted to feet by dividing by 0.3048.

Distance Note

Distances shown on this plan are ground distances and can be converted to grid distances by multiplying by the combined scale factor of 0.99995.

Bearing Note

Bearings are MTM grid, derived from the Can-Net Real Time Network. GPS observations on reference points A and B, shown hereon, having a bearing of N 22° 16' 20" W and are referred to the Central Meridian of MTM Zone 9 (76° 30' West Longitude) Nad 83 (Original).

For bearing comparisons, a rotation of 6° 16' 20" counter-clockwise was applied to bearings on P1.

For bearing comparisons, a rotation of 0° 39' 20" counter-clockwise was applied to bearings on P2, P3, P4 & P5.

Elevation Notes

1. Elevations shown are geodetic and are referred to Geodetic Datum CGVD-1928:1978.
2. It is the responsibility of the user of this information to verify that the job benchmark has not been altered or disturbed and that its relative elevation and description agrees with the information shown on this drawing.

Utility Notes

1. This drawing cannot be accepted as acknowledging all of the utilities and it will be the responsibility of the user to contact the respective utility authorities for confirmation.
2. Only visible surface utilities were located.
3. Underground utility data derived from City of Ottawa utility sheet reference: 7123 (sheet 6).
4. A field location of underground plant by the pertinent utility authority is mandatory before any work involving breaking ground, probing, excavating etc.

Notes & Legend

Denotes	
	Survey Monument Planted
	Survey Monument Found
	Standard Iron Bar
	Short Standard Iron Bar
	Iron Bar
	Witness
	Measured
	Origin Unknown
	Plan GL41521
	Plan GL56001
	Plan 5R-8330
	Plan 4R-13897
	Plan 4R-19602
	Inst GL76777
	Underground Water
	Underground Bell
	Overhead Wires
	Utility Pole
	Anchor
	Light Standard
	Corrugated Steel Pipe
	Bell Terminal Box
	Gas Meter
	Air Conditioner
	Diameter
	Wooden Post
	Chain Link Fence
	Board Fence
	Post and Wire
	Concrete Block
	Top of Slope
	Bottom of Slope
	Invert
	Top of Pipe
	Underside of Eave
	Top of Foundation
	Centreline
	Top of Wall
	Location of Elevations
	Top of Concrete Curb Elevation
	Property Line
	Deciduous Tree
	Coniferous Tree
	Shrub

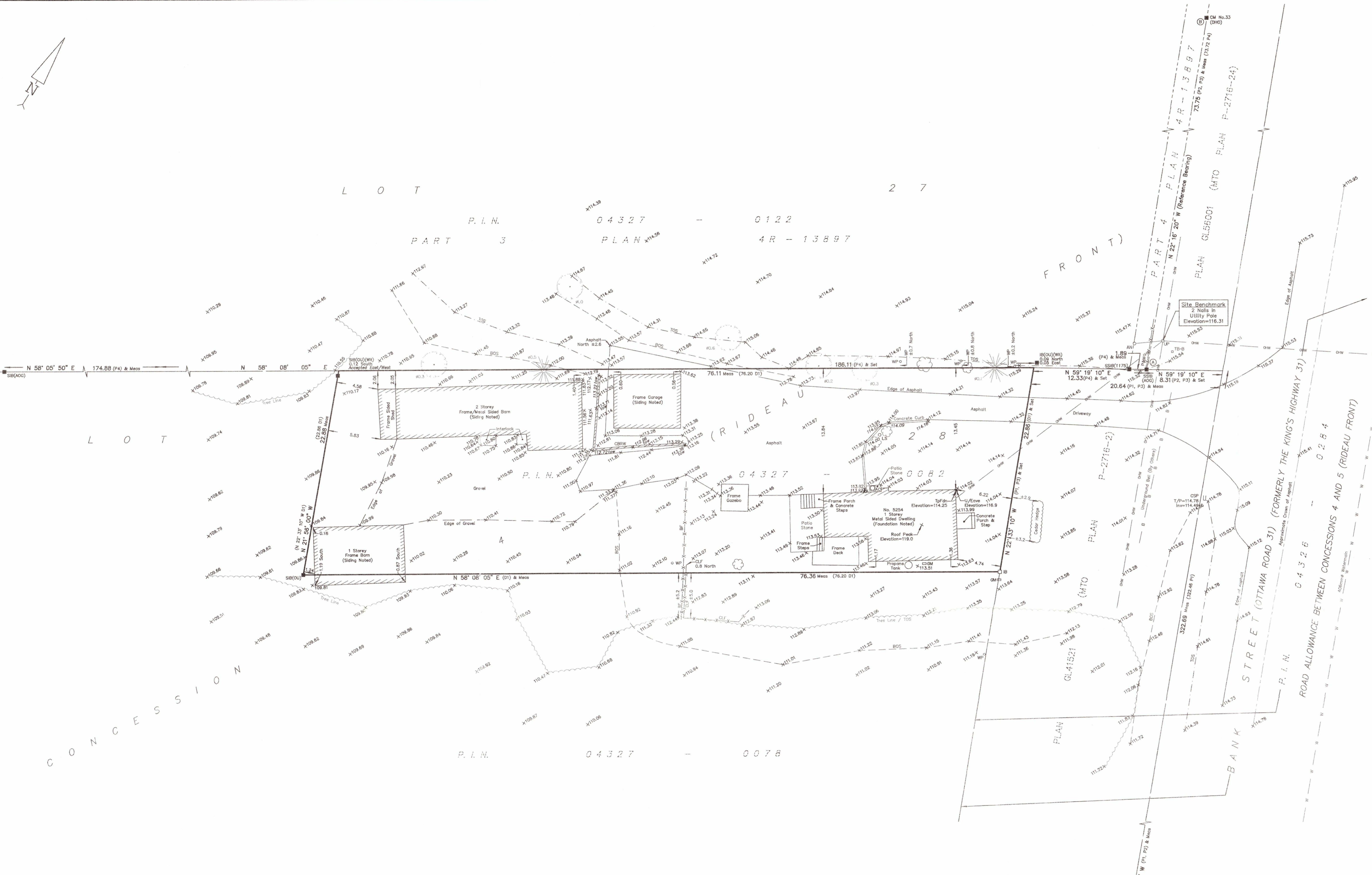

**Surveyor's Certificate**

I certify that:

1. This survey and plan are correct and in accordance with the Surveys Act, the Surveyors Act and the Regulations made under them.
2. The survey was completed on the 15th day of April, 2019.

Date: April 24/19

*Jamie Leslie*  
Jamie Leslie  
Ontario Land Surveyor

ASSOCIATION OF ONTARIO  
LAND SURVEYORS  
PLAN SUBMISSION FORM  
2088411

THIS PLAN IS NOT VALID UNLESS  
IT IS AN UNBROKEN ORIGINAL COPY  
ISSUED BY THE SURVEYOR  
in accordance with  
Regulation 1026, Section 29 (3).

FARLEY, SMITH & DENIS SURVEYING LTD.

ONTARIO LAND SURVEYORS  
CANADA LAND SURVEYORS

190 COLONNADE ROAD, OTTAWA, ONTARIO K2E 7J5  
TEL: (613) 727-8226 FAX: (613) 727-1826

FILE No.: 67-19

Part 1  
PLAN  
4R-19602

PLAN GL56001  
(MTO PLAN  
P-2716-24)

TOPOGRAPHIC DATA WAS COLLECTED UNDER WINTER CONDITIONS. SNOW COVER AND ICE PRECLUDE DETERMINING LOCATION AND ELEVATION OF SOME TOPOGRAPHICAL DATA THAT IS OTHERWISE VISIBLE.

WARNING: NO PERSON MAY COPY, REPRODUCE, DISTRIBUTE OR ALTER THIS PLAN IN WHOLE OR IN PART WITHOUT THE WRITTEN PERMISSION OF FARLEY, SMITH & DENIS SURVEYING LTD. © FARLEY, SMITH & DENIS SURVEYING LTD., 2019.

owner  
 Rayan Zaher  
 364 Wisteria Crescent  
 Ottawa ON

architect  
 unPoised Architecture INC  
 5-16 Sweetland Avenue  
 Ottawa ON

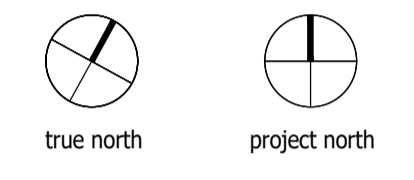

revisions	date
XXXXXX	XXXXXX
XXXXXX	XXXXXX
PROGRESS REVIEW	2023-12-20
SPC SUBMISSION	2023-09-14
PROGRESS REVIEW	2022-12-15

**STORAGE and REPAIR FACILITY**

5254 Bank Street, Ottawa ON

**SITE PLAN and ZONING**

sheet number

**A01**

**ZONING REQUIREMENTS: RG3 [900r]-h - Rural Commercial Industrial (schedule 219 and 220) + BUILDING INFORMATION**

PARKING PROVISIONS (AREA D) Required: 12 <small>321 sq.m service and repair shop = 11 spaces (3.4 spaces / 100 sq.m) 16 sq.m office = 1 space (2.4 spaces / 100 sq.m)</small>	<b>Provided 12 (6 exterior + 6 inside bays)</b>
BICYCLE PARKING PROVISIONS Required: 1 / 1500 sq.m @ 552 sq.m = 0	<b>Provided 0</b>
VEHICLE LOADING SPACE PROVISIONS Required: 1 for 350 to 999 sq.m @ 552 sq.m = 0	<b>Provided 0</b>
MINIMUM FRONT YARD SETBACK Required: 15m (49'-3")	<b>Provided 1.02 m (3'-4")</b>
MINIMUM NORTH INTERIOR SIDE YARD SETBACK Required: 3m (9'-11") from RG ZONE	<b>Provided 13.41 m (44'-0")</b>
MINIMUM SOUTH INTERIOR SIDE YARD SETBACK Required: 8m (26'-3") from ME2 ZONE	<b>Provided 0.61 m (2'-0")</b>
REAR YARD SETBACK Required: 15m (49'-3")	<b>Provided 38.30 m (125'-8")</b>
MAXIMUM BUILDING HEIGHT Required: 15m (49'-3")	<b>Provided 8.23 m (27'-0")</b>
MAXIMUM LOT COVERAGE Required: 50%	<b>Provided 16 %</b>

LOT AREA	<b>18,342 sq.ft (1,704 sq.m)</b>
GROSS AREA <small>zoning definition</small>	<b>4,010 sq.ft (373 sq.m)</b>
BUILDING AREA	<b>2,961 sq.ft (275 sq.m)</b>
GROSS AREA <small>building code definition</small>	<b>2,961 sq.ft (275 sq.m) - does not include mezzanine</b>
BUILDING HEIGHT	<b>1 storey (mezzanine not included as storey)</b>
FACING STREET	<b>1</b>
OCCUPANCY TYPE	<b>F2 - medium hazard industrial</b>
BUILDING FIRE SAFETY	<b>Part 3 - 3.2.2.71</b>
PERMITTED CONSTRUCTION	<b>Combustible or Non - Combustible</b>

**LEGEND**

- LC - LIGHT UNDER CANOPY
- LW - LIGHT WALL MOUNT
- DP - DEPRESSED CURB
- WB - IN-GROUND WASTE BIN
- CU - PRECAST CONCRETE CURB STOP

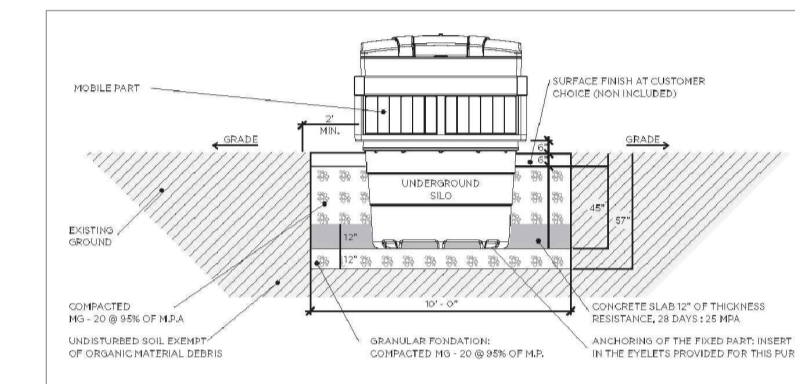

DETAIL FOR IN-GROUND WASTE BIN

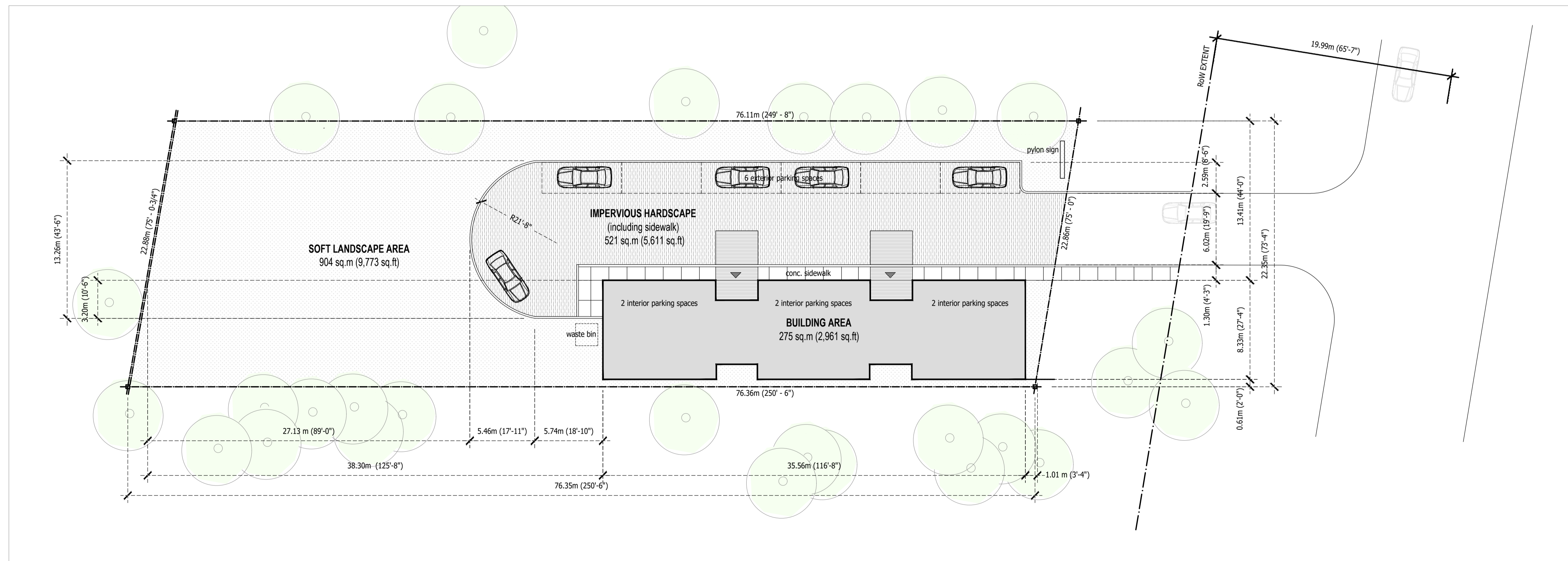

SITE PLAN

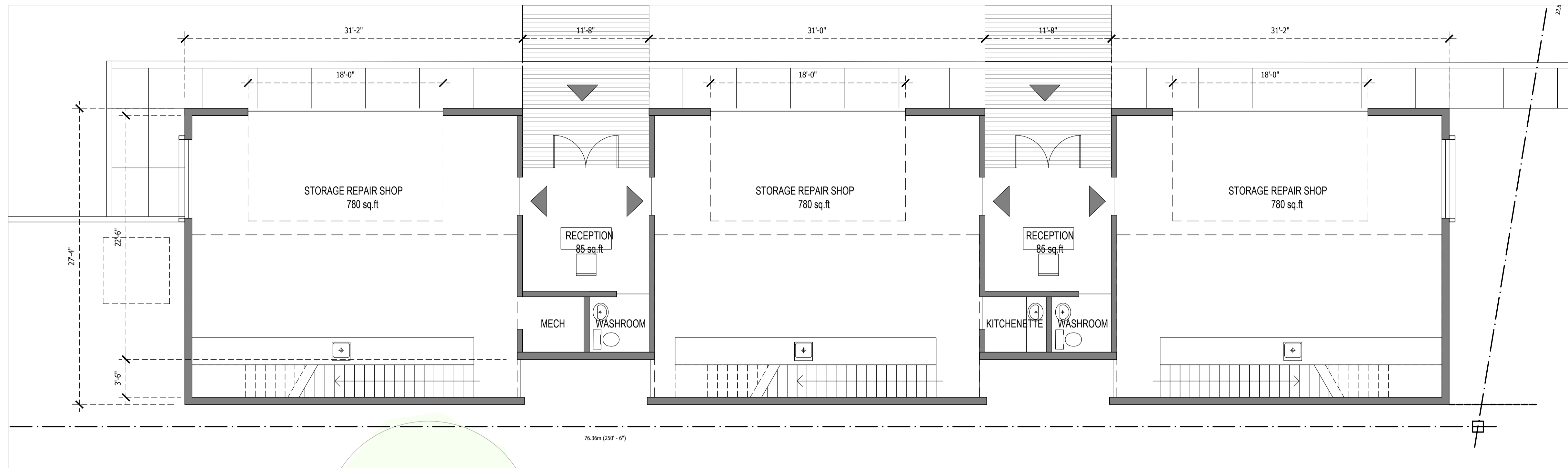

FIRST FLOOR PLAN

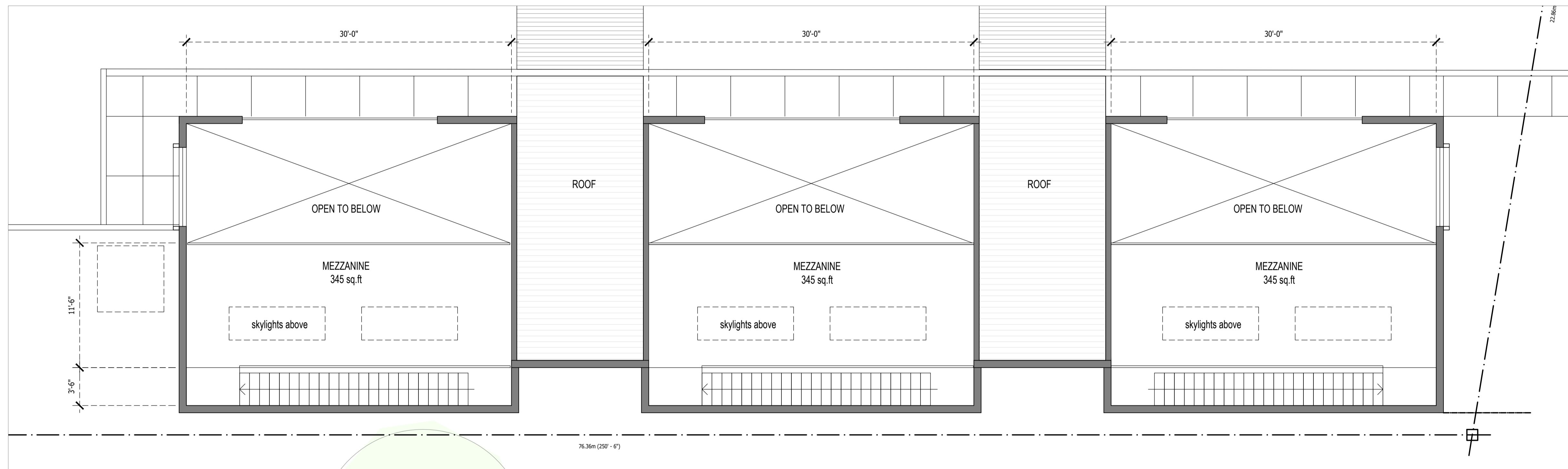

MEZZANINE PLAN

owner  
Rayan Zaher  
364 Wisteria Crescent  
Ottawa ON

architect  
unPoised Architecture INC  
5-16 Sweetland Avenue  
Ottawa ON

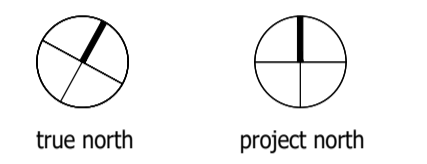

revisions	date
XXXXX	XXXXX
XXXXX	XXXXX
XXXXX	XXXXX
XXXXX	XXXXX
XXXXX	XXXXX
PROGRESS REVIEW	2023-12-20
project title	

**STORAGE and REPAIR FACILITY**

5254 Bank Street, Ottawa ON

drawing title  
**FLOOR PLANS**

sheet number

**A02**



NORTH ELEVATION



SOUTH ELEVATION



EAST ELEVATION



WEST ELEVATION

owner  
 Rayan Zaher  
 364 Wisteria Crescent  
 Ottawa ON

architect  
 unPoised Architecture INC  
 5-16 Sweetland Avenue  
 Ottawa ON



revisions	date
XXXXXX	XXXXXX
XXXXXX	XXXXXX
XXXXXX	XXXXXX
XXXXXX	XXXXXX
PROGRESS REVIEW	2023-12-20
SPC SUBMISSION	2023-09-14

project title  
**STORAGE and REPAIR FACILITY**  
 5254 Bank Street, Ottawa ON  
 drawing title  
**ELEVATIONS**

sheet number  
**A03**