



URBAN FORESTRY & FOREST MANAGEMENT CONSULTING

P.O. Box 13593, STN. KANATA, OTTAWA, ON K2K 1X6
TELEPHONE: (613) 850-2475
WEBSITE: WWW.IFSASSOCIATES.CA

April 27, 2026

Alexa Volkov
Senior Research Analyst, Housing Policy
SHS Inc.
77 Bloor Street West, Suite 600
Toronto, ON
M5S 1M2

RE: TREE PROTECTION PLAN FOR 2040 ARROWSMITH DRIVE, OTTAWA

This tree protection plan was prepared by IFS Associates Inc. (IFS Inc.) in support of a building permit for 2040 Arrowsmith Drive in Ottawa. The need for this report is related to trees protected under the City of Ottawa's Tree Protection By-law (By-law No. 2020-340). The work proposed includes demolishing existing buildings and construction of a six-storey mixed-use building (see plan on page 7 of this report). A driveway with retaining wall and curb is proposed for the rear of the building and is adjacent to a stand of trees on the neighbouring property at 2000 Jasmine Crescent. This plan details efforts to ensure the successful retention of these trees.

Importantly, although this report may be used to support the application for a tree removal permit, it does not by itself constitute permission to remove trees or begin site clearing activities. No such work should occur before a tree removal permit is issued authorizing the injury or destruction of a tree in accordance with the By-law.

The inventory in this report details the assessment of nineteen trees - five located fully on the subject property and the remainder on the neighbouring property. No trees were found on nearby City of Ottawa lands. Field work for this report was completed in February 2026.

TREE SPECIES, CONDITION, SIZE AND STATUS

Table 1 on pages 2 through 6 details the individual trees on the subject and adjacent private property. These trees are referenced by the numbers plotted on the tree protection plan included on page 7 of this report. The numbering of the trees follows that used for the tree conservation report prepared by Lennox & Associates landscape architects. Pictures 1 to 4 on pages 13, 14 and 15 show the trees and their current growing environment.

Table 1. Tree information for 2040 Arrowsmith Drive

| Tree No. | Tree species /Tolerance to Construction ¹ | Owner -ship ² | DBH ³ (cm) | CRZ ⁴ (m) | SRZ ⁵ (m) | Distance to excavation (m) ⁶ | Tree Condition, Age Class, Condition Notes, Species Origin and Status (to be removed or preserved and protected) | Reason for removal | Forester's Opinion re. Removal |
|----------|--|---------------------------|-----------------------|----------------------|----------------------|---|---|----------------------------------|--------------------------------|
| 8 | Colorado spruce (<i>Picea pungens</i>) / Moderate - Good | Private onsite | 38.5 | - | - | - | Fair; mature; single dominant main stem and leader; fair crown density, annual increment and needle colour; scattered dieback, consistent deadwood where shaded; introduced species; to be removed | Conflicts with garbage area | Tree and stump be removed |
| 9 | Colorado spruce (<i>Picea pungens</i>) / Moderate - Good | Private on adjoining site | 31.0 | 3.1 | 0.93 | >4 | Fair; mature; single dominant main stem and leader; fair crown density, annual increment and needle colour; scattered dieback, consistent deadwood where shaded; introduced species; to be preserved and protected | Not applicable – to be preserved | NA |
| 10 | Colorado spruce (<i>Picea pungens</i>) / Moderate - Good | Private on adjoining site | 32.5 | 3.3 | 0.98 | 3.0 | Fair; mature; single dominant main stem and leader; fair crown density, annual increment and needle colour; scattered dieback, consistent deadwood where shaded; introduced species; to be preserved and protected | Not applicable – to be preserved | NA |
| 11 | Colorado spruce (<i>Picea pungens</i>) / Moderate - Good | Private on adjoining site | 32.5 | 3.3 | 0.98 | >4 | Fair; mature; single dominant main stem and leader; fair crown density, annual increment and needle colour; scattered dieback, consistent deadwood where shaded; introduced species; to be preserved and protected | Not applicable – to be preserved | NA |

Table 1. Cont.

| Tree No. | Tree species /Tolerance to Construction ¹ | Owner ship ² | DBH ³ (cm) | CRZ ⁴ (m) | SRZ ⁵ (m) | Distance to excavation (m) ⁶ | Tree Condition, Age Class, Condition Notes, Species Origin and Status (to be removed or preserved and protected) | Reason for removal | Forester's Opinion re. Removal |
|----------|--|---------------------------|-----------------------|----------------------|----------------------|---|---|----------------------------------|--------------------------------|
| 12 | Colorado spruce (<i>Picea pungens</i>) / Moderate - Good | Private on adjoining site | 36.7 | 3.7 | 1.1 | 3.2 | Fair; mature; single dominant main stem and leader; fair crown density, annual increment and needle colour; scattered dieback, consistent deadwood where shaded; introduced species; to be preserved and protected | Not applicable – to be preserved | NA |
| 13 | Colorado spruce (<i>Picea pungens</i>) / Moderate - Good | Private on adjoining site | 28.5 | 2.9 | 0.86 | >5 | Fair; mature; single dominant main stem and leader; fair crown density, annual increment and needle colour; scattered dieback, consistent deadwood where shaded; introduced species; to be preserved and protected | Not applicable – to be preserved | NA |
| 14 | Colorado spruce (<i>Picea pungens</i>) / Moderate - Good | Private on adjoining site | 32.8 | 3.3 | 0.98 | 2.7 | Fair; mature; single dominant main stem and leader; fair crown density, annual increment and needle colour; scattered dieback, consistent deadwood where shaded; introduced species; to be preserved and protected | Not applicable – to be preserved | NA |
| 15 | Colorado spruce (<i>Picea pungens</i>) / Moderate - Good | Private on adjoining site | 27.3 | 2.7 | 0.82 | >5 | Fair; mature; single dominant main stem and leader; fair crown density, annual increment and needle colour; scattered dieback, consistent deadwood where shaded; introduced species; to be preserved and protected | Not applicable – to be preserved | NA |

Table 1. Cont.

| Tree No. | Tree species /Tolerance to Construction ¹ | Owner ship ² | DBH ³ (cm) | CRZ ⁴ (m) | SRZ ⁵ (m) | Distance to excavation (m) ⁶ | Tree Condition, Age Class, Condition Notes, Species Origin and Status (to be removed or preserved and protected) | Reason for removal | Forester's Opinion re. Removal |
|----------|--|---------------------------|-----------------------|----------------------|----------------------|---|---|----------------------------------|--------------------------------|
| 16 | Colorado spruce (<i>Picea pungens</i>) / Moderate - Good | Private on adjoining site | 30.2 | 3.0 | 0.91 | 1.7 | Fair; mature; single dominant main stem and leader; fair crown density, annual increment and needle colour; scattered dieback, consistent deadwood where shaded; introduced species; to be preserved and protected | Not applicable – to be preserved | NA |
| 17 | Colorado spruce (<i>Picea pungens</i>) / Moderate - Good | Private on adjoining site | 36.4 | 3.6 | 1.1 | 4 | Fair; mature; single dominant main stem and leader; fair crown density, annual increment and needle colour; scattered dieback, consistent deadwood where shaded; introduced species; to be preserved and protected | Not applicable – to be preserved | NA |
| 18 | Colorado spruce (<i>Picea pungens</i>) / Moderate - Good | Private onsite | 23.2 | - | - | - | Very poor; mature; single dominant main stem; leader dead; only 1/3 of crown alive; poor crown density, fair annual increment and needle colour; introduced species; to be removed | Very poor condition | Tree and stump be removed |
| 19 | Colorado spruce (<i>Picea pungens</i>) / Moderate - Good | Private on adjoining site | 34.7 | 3.5 | 1.0 | >4 | Fair; mature; single dominant main stem and leader; fair crown density, annual increment and needle colour; scattered dieback, consistent deadwood where shaded; introduced species; to be preserved and protected | Not applicable – to be preserved | NA |

Table 1. Cont.

| Tree No. | Tree species /Tolerance to Construction ¹ | Owner ship ² | DBH ³ (cm) | CRZ ⁴ (m) | SRZ ⁵ (m) | Distance to excavation (m) ⁶ | Tree Condition, Age Class, Condition Notes, Species Origin and Status (to be removed or preserved and protected) | Reason for removal | Forester's Opinion re. Removal |
|----------|--|---------------------------|-----------------------|----------------------|----------------------|---|---|---|--------------------------------|
| 20 | Colorado spruce (<i>Picea pungens</i>) / Moderate - Good | Private onsite | 33.1 | - | - | - | Poor; mature; central stem with competing lateral at 8.5m on north - poor form; fair crown density, annual increment and needle colour; introduced species; to be removed | Will not survive root loss related to excavation for curb | Tree and stump be removed |
| 21 | Colorado spruce (<i>Picea pungens</i>) / Moderate - Good | Private on adjoining site | 24.2 | 2.4 | 0.73 | >4 | Fair; mature; single dominant main stem and leader; fair crown density, annual increment and needle colour; scattered dieback, consistent deadwood where shaded; introduced species; to be preserved and protected | Not applicable – to be preserved | NA |
| 22 | Colorado spruce (<i>Picea pungens</i>) / Moderate - Good | Private onsite | 29.2 | - | - | - | Poor; mature; central stem with competing lateral at 10m on south - poor form; fair crown density, annual increment and needle colour; introduced species; to be removed | Will not survive root loss related to excavation for curb | Tree and stump be removed |
| 23 | Colorado spruce (<i>Picea pungens</i>) / Moderate - Good | Private onsite | 42.0 | - | - | - | Fair; mature; central stem with competing leaders at 10m; fair crown density, annual increment and needle colour; introduced species; to be removed | Conflicts with proposed curb | Tree and stump be removed |

Table 1. Cont.

| Tree No. | Tree species /Tolerance to Construction ¹ | Owner ship ² | DBH ³ (cm) | CRZ ⁴ (m) | SRZ ⁵ (m) | Distance to excavation (m) ⁶ | Tree Condition, Age Class, Condition Notes, Species Origin and Status (to be removed or preserved and protected) | Reason for removal | Forester's Opinion re. Removal |
|----------|--|---------------------------|-----------------------|----------------------|----------------------|---|---|----------------------------------|--------------------------------|
| 24 | Colorado spruce (<i>Picea pungens</i>) / Moderate - Good | Private on adjoining site | 33.0 | 3.3 | 1.0 | 3.0 | Fair; mature; single dominant main stem and leader; fair crown density, annual increment and needle colour; scattered dieback, consistent deadwood where shaded; introduced species; to be preserved and protected | Not applicable – to be preserved | NA |
| 25 | Colorado spruce (<i>Picea pungens</i>) / Moderate - Good | Private on adjoining site | 30.8 | 3.1 | 0.92 | >7 | Fair; mature; single dominant main stem and leader; fair crown density, annual increment and needle colour; scattered dieback, consistent deadwood where shaded; introduced species; to be preserved and protected | Not applicable – to be preserved | NA |
| 26 | Colorado spruce (<i>Picea pungens</i>) / Moderate - Good | Private on adjoining site | 36.6 | 3.7 | 1.1 | >10 | Fair; mature; single dominant main stem and leader; fair crown density, annual increment and needle colour; living crown held high due to consistent shading from surrounding trees; introduced species; to be preserved and protected | Not applicable – to be preserved | NA |

¹As taken from Managing Trees during Construction; 2nd Ed., Fite and Smiley; ² Tree location/ownership taken from grading plan prepared by D.B. Gray Engineering; ³ Diameter at breast height, or 1.3m from grade (unless otherwise indicated); ⁴ Critical root zone (CRZ) is 10 centimetres from the trunk of a tree for every centimetre of DBH. The CRZ is calculated as DBH x 10 cm; ⁵ Static root zone (SRZ) is considered three times the DBH and is considered the zone in which no roots can be cut; ⁶Approximate distances only.

GENERAL NOTES

PLANS COMPLETED BY D. B. GRAY ENGINEERING INC. (09/03/26)

LEGEND

- TREE TO REMAIN
- STATIC ROOT ZONE
- CRITICAL ROOT ZONE
- PROTECTIVE FENCING
- TREE TO BE REMOVED

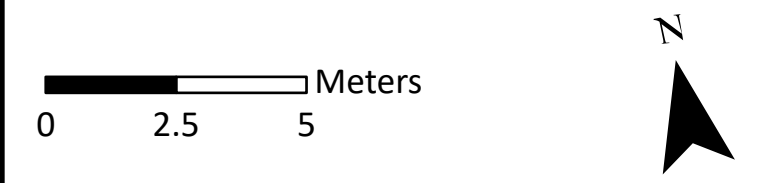

DRAWING: Tree Protection Plan

PROJECT: 2040 ARROWSMITH DRIVE
CITY OF OTTAWA



Andrew K. Boyd, R.P.F.

| | |
|------------------|-------------|
| SCALE: 1:145 | DRAWING NO. |
| DATE: 2026-03-10 | 2040 |
| DRAWN BY: SS | |
| SHEET NO. 1 | |

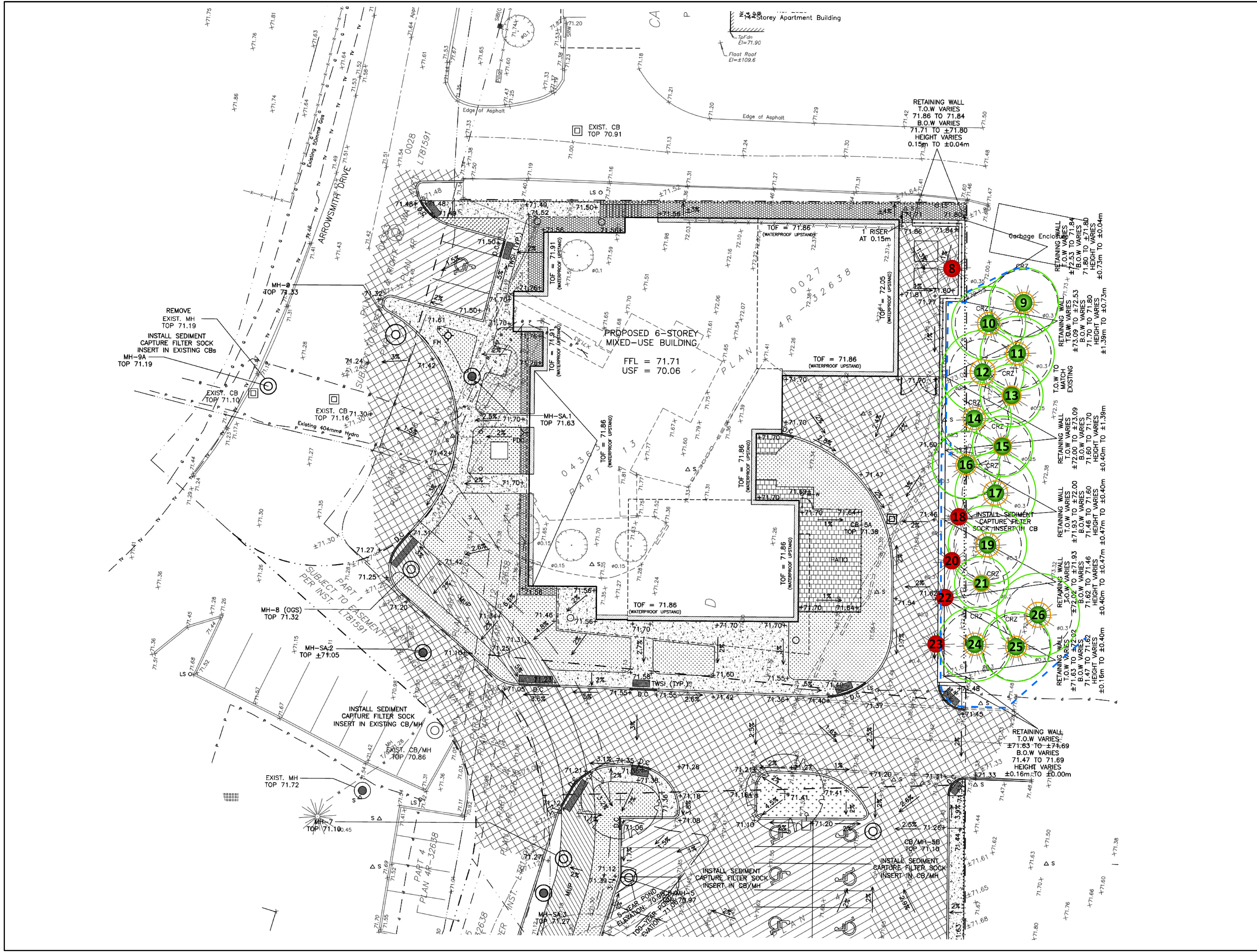

TREE PROTECTION MEASURES

Protection measures intended to mitigate damage during construction will be applied to the neighbouring trees to be preserved. The following measures are the minimum required by the City of Ottawa to ensure tree survival during and following construction:

1. Erect a fence as close as possible to the critical root zone (CRZ) of trees (City of Ottawa tree protection barrier detail included on page 11). Portions of this fence will be moved as necessary (and temporarily) for access purposes when constructing the retaining wall and when completing grading.
2. Do not place any material or equipment within the CRZ of the tree.
3. Do not attach any signs, notices or posters to any tree.
4. Do not raise or lower the existing grade within the CRZ without approval.
5. Tunnel or bore when digging within the CRZ of a tree.
6. Do not damage the root system, trunk or branches of any tree.
7. Ensure that exhaust fumes from all equipment are NOT directed towards any tree's crown.

TREE PRESERVATION MEASURES

As excavation for the proposed retaining wall is proposed within the CRZs of trees #10, 12, 14, 16 and 24, the following measures will be taken:

1. Hydro excavation along the edge of excavation in proximity to the tree to carefully expose roots. Exposed roots will then be cleanly cut and sealed before being reburied (see City of Ottawa root pruning detail on page 12). Excavation can then resume using traditional mechanical means. Sealing the cleanly cut root ends with a beeswax product will help prevent the loss of moisture and facilitate healing.
2. If the excavation is to be left open for any length of time a covering of at least three layers of moistened burlap is to be draped over the exposed face of excavation closet to the tree. A final covering of clear plastic will help retain moisture within the burlap. The use of burlap and plastic coverings will help reduce the loss of moisture from the soil surrounding the remaining roots.

STUMP REMOVAL

The stumps of trees #1 through 8 will be excavated as part of typical site preparation. No special considerations are required. It is recommended to leave stumps of trees #18 and 20 in place, cut as low as possible to the ground. This will avoid damaging roots of the trees to remain (nearby trees of the same species will fuse roots). If stump grinding is necessary then only the stumps themselves, and not surrounding root plate, should be ground down 10-15cm, the grindings removed and backfilled with topsoil. Topsoil can be added to cover any exposed surface roots within the root plate.

The stumps of trees #22 and 23 will be partially removed to install the proposed retaining wall. It is likely an excavator will be used for this work. If root pruning is completed first little damage to the roots of adjacent trees is anticipated.

RESPONSES TO CITY COMMENTS

1a) *How will the trees shown as “to remain” be protected through the grading work and retaining wall installation?*

As detailed in tree protection measures, a protective fence will be installed following the City of Ottawa’s tree protection barrier specifications.

1b) *What extent of impact to the CRZs of these retained trees will occur and will it cause retained tree health to decline? Will there be excavation within the static root zone of the tree (Diameter x 3)?*

At most, 30% of one tree’s CRZ (tree #16) will be impacted by grading. This equals the maximum recommended in ISA best management practices. As shown in the plan on page 7, no static root zones will be impacted.

1c) *What tools and mitigation measures will be used when excavating within the CRZ of retained trees (for example, will a hydrovac or air knife be used? Where and why?)*

As detailed in tree preservation measures, hydro excavation and root pruning will be conducted along the length of the proposed retaining wall on the east side of the project area.

1d) *How will removal of 2040 Arrowsmith owned tree #s 18, 20, 22, 23 impact the retained trees? Will the stumps be left in place to minimize soil disturbance? Provide more details on the tree and stump removal plan. Note, leaving the stump and grinding it would be ideal to not create more soil disturbance for the relevant trees.*

As detained in stump removal, where possible stumps from trees #18, 20, 22 and 23 will be fully left in place. If grinding is necessary, just the stump themselves will be ground down and not the surrounding root plate. Both measures will reduce the possibility of disturbing roots of adjacent retained trees.

1e) *Provide as much detail as possible to confirm the planned removals, grading, and other associated construction work in this area will not have significant impacts on the health OR force removal of the retained trees.*

Tree and stump removals, grading and other associated construction work have been minimized/ mitigated to the point that the health of nearby retained trees will not be impacted. The forced removal of retained trees is certainly not anticipated.

1f) *Address how the retained trees will be influenced by the wind after the removals occur and whether any mitigation measures apply.*

Retained trees #16, 17, 19, 21, and 24 will be exposed directly to prevailing winds once trees #18, 20, 22 and 23 are removed. To help mitigate any possible negative impacts, two measures are proposed: i) the installation of amour stone blocks on the western side of the root plates of remaining trees to aid in their wind firmness (as most stones will be placed on their property, this will require written permission of the owner of 2000 Jasmine Crescent); ii) planting of conifers in place of the removed trees. As with the amour stones, tree planting is proposed to occur on the neighbouring property so will require their permission as well. Norway spruce (*Picea abies*) trees are recommended. Digging of planting holes by hand is recommended to help avoid damaging roots of retained trees. Preferably, the amour stones will be installed prior to construction and the trees planted following the completion of construction.

1g) *The consulting engineer and RPF must discuss the grade changes proposed along the eastern edge of the site. The trees are growing on a berm. A retaining wall, curb and access road will be installed along the edge of this growing space. Identify the implications of this work in the plan.*

The consulting engineer and forester have discussed the implications of the work proposed along the eastern edge of the site. Grading behind the proposed retaining wall remains as existing. Approximately 30% of the CRZ of tree #16 will be impacted while lesser amounts of the CRZs of trees #10, 12, 14 and 24 will be impacted.

This report is subject to the attached Limitations of Tree Assessments and Liability to which the reader's attention is directed.

Please do not hesitate to contact me with any questions concerning this report.

Yours,



Andrew K. Boyd, B.Sc.F, R.P.F. (#1828)
Certified Arborist #ON-0496A
Consulting Urban Forester

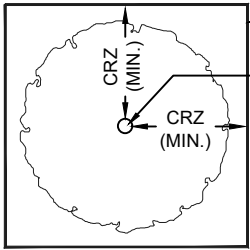

TREE PROTECTION FENCING
TREE TRUNK

PLAN VIEW

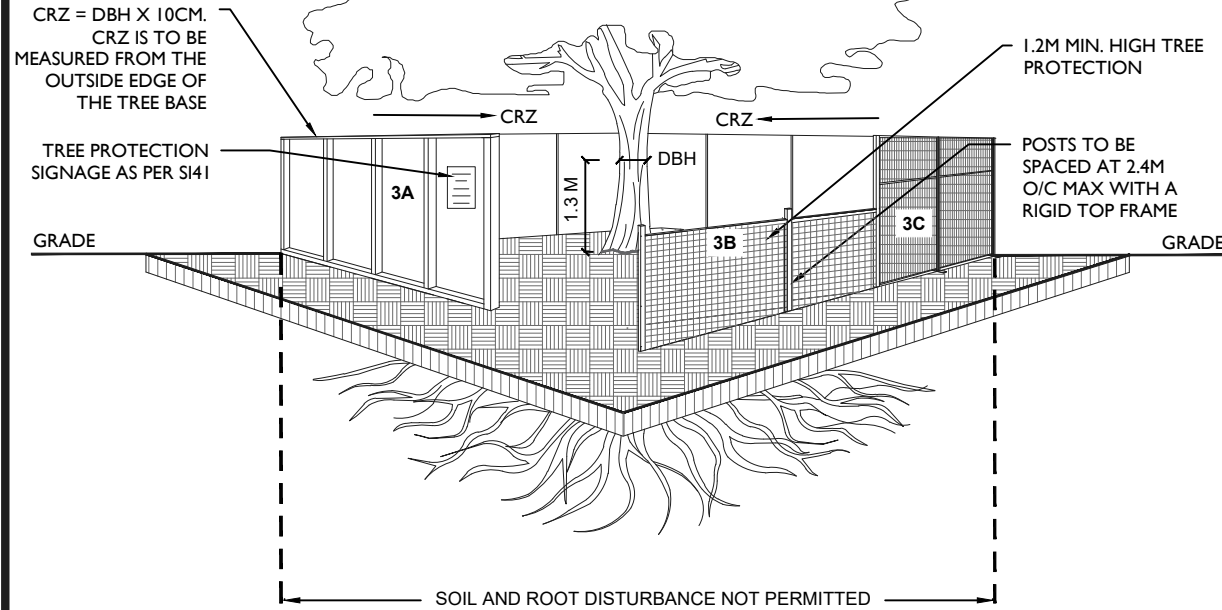

TREE PROTECTION REQUIREMENTS:

1. TREE PROTECTION FENCING MUST BE INSTALLED PER THE TREE CONSERVATION REPORT (TCR) OR THE TREE INFORMATION REPORT (TIR), WHICH EVER APPLIES, AND MUST BE DETERMINED BY AN ARBORIST AND APPROVED BY CITY FORESTRY STAFF PRIOR TO THE COMMENCEMENT OF THE WORK AND REMAIN IN PLACE UNTIL THE WORK IS COMPLETE.
 2. FOR WORK WITHIN THE TREE PROTECTION ZONE (TPZ):
 - DO NOT PLACE OR STORE ANY MATERIAL, FILL OR EQUIPMENT (INCLUDING OUTHOUSES)
 - DO NOT ATTACH ANY SIGNS, NOTICES OR POSTERS TO ANY TREE.
 - DO NOT RAISE OR LOWER THE EXISTING GRADE (SCRAPING OF THE TOP LAYER OF SOIL FOR FINAL GRADING MUST BE AVOIDED WITHIN THE CRZ, THIS INCLUDES FINAL LANDSCAPE/ REINSTATEMENT GRADING).
 - ENSURE THAT EXHAUST FUMES FROM ALL EQUIPMENT ARE DIRECTED AWAY FROM THE TREE CANOPY
 - DO NOT EXTEND/REINSTATE HARD SURFACE WITHIN THE CRZ
 - DO NOT DISPOSE OF WASTE OR VOLATILE MATERIALS, SUCH AS MINERAL SPIRITS, OIL OR PAINT THINNER
 - DO NOT OPERATE, PARK, REPAIR, OR REFUEL VEHICLES OR EQUIPMENT.
 - DO NOT DAMAGE THE ROOT SYSTEM, TRUNK OR BRANCHES OF ANY TREE
 - EXCAVATION SHALL BE CARRIED OUT BY TUNNELING, BORING OR HYDRO VAC
 3. TREE PROTECTION FENCING MUST BE AT LEAST 1.2M IN HEIGHT AND BE CONSTRUCTED OF RIGID OR FRAMED MATERIALS SUCH AS:
 - A. PLYWOOD HOARDING
 - B. SNOW FENCE
 - C. MODULAR STEEL PANELS
- INSTALLATION OF ALL FENCING TYPES, A, B OR C, MUST MINIMIZE DAMAGE TO EXISTING ROOTS.
4. ANY DEVIATION TO THE APPROVED TREE PROTECTION FENCING LOCATION MUST BE SUPERVISED BY AN ARBORIST AND APPROVED BY CITY FORESTRY STAFF. MODIFICATIONS MAY INCLUDE THE INSTALLATION OF PLYWOOD, WOOD CHIPS, OR STEEL PLATING OVER THE ROOTS, OR PERFORMING PROPER ROOT PRUNING AND CARE WHERE ROOTS ARE ENCOUNTERED.
 5. IF TREES ARE BEING AFFECTED BY CONSTRUCTION, A WATER AND FERTILIZING PROGRAM MAY BE REQUIRED.
 6. THE CITY OF OTTAWA'S TREE PROTECTION BY-LAW (NO. 2020-340) AND STANDARD F-8011 APPLY



Tree Protection

SCALE: NTS

DATE: JANUARY 2026

DRAWING NO.: F7

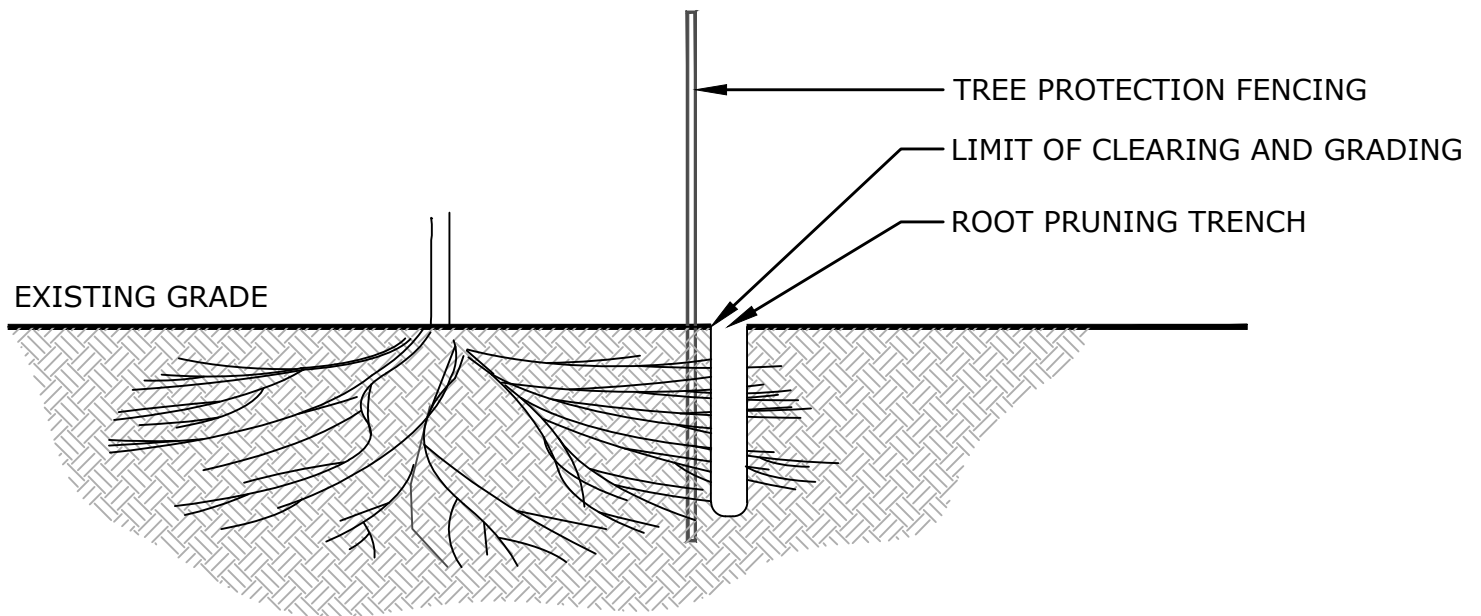

NOTES:

1. PROPER ROOT PRUNING TECHNIQUES REQUIRED WHEN TREE ROOTS ARE ENCOUNTERED DURING EXCAVATION.
2. EXCAVATION (ROOT PRUNING TRENCH) SHALL BE CARRIED OUT BY TUNNELING, BORING OR HYDRO VAC.
3. ROOTS ARE TO BE CLEANLY CUT AND THE AREA AROUND THE ROOTS SHALL BE BACKFILLED WITH SUITABLE MATERIAL, AS DETAILED IN THE CONTRACT DRAWINGS.
4. TREES SHALL BE PRUNED TO RESTORE TREE APPEARANCE AND/OR RESTORE THE BALANCE BETWEEN TOP GROWTH AND ROOTS.
5. LEADERS SHALL NOT BE PRUNED.



Picture 1. Trees #8 to 23 (left to right) – Colorado spruce trees on and adjacent to 2040 Arrowsmith Drive



Picture 2. Rooting conditions below Colorado spruce trees on and adjacent to 2040 Arrowsmith Drive (note exposed surface roots)



Picture 3. Lines of Colorado spruce trees adjacent to 2040 Arrowsmith Drive



Picture 4. Colorado spruce trees on and adjacent to 2040 Arrowsmith Drive (note trees marked for removal with flagging tape)

LIMITATIONS OF TREE ASSESSMENTS & LIABILITY

GENERAL

It is the policy of Integrated Forestry Services Inc. (IFS Inc.) to attach the following clause regarding limitations. We do this to ensure that our clients are clearly aware of what is technically and professionally realistic in assessing trees for retention.

This report was prepared by IFS Inc. at the request of the client. The information, interpretation and analysis expressed in this report are for the sole benefit and exclusive use of the client. Possession of this report or a copy thereof does not imply right of publication or use for any purpose by any other than the client to whom it is addressed. Unless otherwise required by law, neither all or any part of the contents of this report, nor copy thereof, shall be conveyed by anyone, including the client, to the public through public relations, news or other media, without the prior expressly written consent of the author, and especially as to value conclusions, identity of the author, or any reference to any professional society or institute or to any initialed designation conferred upon the author as stated in his qualifications.

This report and any values expressed herein represent the opinion of the author; his fee is in no way contingent upon the reporting of a specified value, a stipulated result, nor upon any finding to be reported.

Details obtained from photographs, sketches, *etc.*, are intended as visual aids and are not to scale. They should not be construed as engineering reports or surveys. Although every effort has been made to ensure that this assessment is reasonably accurate, the tree(s) should be reassessed at least annually. The assessment presented in this report is valid at the time of the inspection only. The loss or alteration of any part of this report invalidates the entire report.

LIMITATIONS

The information contained in this report covers only the tree(s) in question and no others. It reflects the condition of the assessed tree(s) at the time of inspection and was limited to a visual examination of the accessible portions only. Integrated Forestry Services Inc. has prepared this report in a manner consistent with that level of care and skill ordinarily exercised by members of the forestry and arboricultural professions, subject to the time limits and physical constraints applicable to this report. The assessment of the tree(s) presented in this report has been made using accepted arboricultural techniques. These include a visual examination of the above-ground portions of each tree for structural defects, scars, cracks, cavities, external indications of decay such as fungal fruiting bodies, evidence of insect infestations, discoloured foliage, the condition of any visible root structures, the degree and direction of lean (if any), the general condition of the tree(s) and the surrounding site, and the proximity of people and property. Except where specifically noted in the report, the tree(s) examined were not dissected, cored, probed or climbed to gain further evidence of their structural condition. Also, unless otherwise noted, no detailed root collar examinations involving excavation were undertaken.

While reasonable efforts have been made to ensure that the tree(s) proposed for retention are healthy, no warranty or guarantee, expressed or implied, are offered that these trees, or any parts of them, will remain standing. This includes other trees on or off the property not examined as part of this assignment. It is both professionally and practically impossible to predict with

absolute certainty the behaviour of any single tree or groups of trees or their component parts in all circumstances, especially when within construction zones. Inevitably, a standing tree will always pose some risk. Most trees have the potential for failure in the event of root loss due to excavation and other construction-related impacts. This risk can only be eliminated through full tree removal.

Notwithstanding the recommendations and conclusions made in this report, it must be realized that trees are living organisms, and their health and vigour constantly change over time. They are not immune to changes in site conditions, or seasonal variations in the weather. It is a condition of this report that IFS Inc. be notified of any changes in tree condition and be provided an opportunity to review or revise the recommendations within this report. Recognition of changes to a tree's condition requires expertise and extensive experience. It is recommended that *IFS Inc.* be employed to re-inspect the tree(s) with sufficient frequency to detect if conditions have changed significantly.

ASSUMPTIONS

Statements made to IFS Inc. regarding the condition, history and location of the tree(s) are assumed to be correct. Unless indicated otherwise, all trees under investigation in this report are assumed to be on the client's property. A recent survey prepared by a Licensed Ontario Land Surveyor showing all relevant trees, both on and adjacent to the subject property, will be provided prior to the start of field work. The final version of the grading plan for the project will be provided prior to completion of the report. Any further changes to this plan invalidate the report on which it is based. Integrated Forestry Services Inc. must be provided with the opportunity to revise the report in relation to any significant changes to the grading plan. The procurement of said survey and grading plan, and the costs associated with them both, are the responsibility of the client, not IFS Inc.

LIABILITY

Without limiting the foregoing, no liability is assumed by IFS Inc. for:

- 1) Any legal description provided with respect to the property.
- 2) Issues of title and/or ownership with respect to the property.
- 3) The accuracy of the property line locations or boundaries with respect to the property.
- 4) The accuracy of any other information provided by the client or third parties.
- 5) Any consequential loss, injury or damages suffered by the client or any third parties, including but not limited to replacement costs, loss of use, earnings and business interruption; and,
- 6) The unauthorized distribution of the report.

Further, under no circumstances may any claims be initiated or commenced by the client against IFS Inc. or any of its directors, officers, employees, contractors, agents or assessors, in contract or in tort, more than 12 months after the date of this report.

ONGOING SERVICES

Integrated Forestry Services Inc. accepts no responsibility for the implementation of any or all parts of the report, unless specifically requested to supervise the implementation or examine the results of activities recommended herein. If further examination or supervision is requested, that request shall be made in writing and the details, including fees, agreed to in advance.