



**Site Servicing & Stormwater Management Report  
CF Rideau Centre Registry Site  
70 Nicholas Street  
Ottawa, Ontario  
December 2022**

**Prepared For:**

**Cadillac Fairview Corporation Limited**

**Submitted To:**

**City of Ottawa**

**Parson's Project # 477846**

# TABLE OF CONTENTS

<b>1.0</b>	<b>INTRODUCTION</b>	<b>1</b>
1.1	Site Description and Proposed Development	1
1.2	Design Guidelines	2
1.3	Existing Infrastructure	3
1.4	Consultations and Permits	3
1.4.1	Consultations	4
1.4.2	Permits and Approvals	4
1.5	Geotechnical Recommendations	4
1.5.1	Site Grading and Preparation	4
1.5.2	Pavement Structure	6
1.5.3	Foundation Drainage and Backfill	6
1.5.4	Excavation Side Slopes	7
1.5.5	Pipe Bedding and Backfill	8
1.5.6	Groundwater Control	8
1.5.7	Winter Construction	9
<b>2.0</b>	<b>WATER SERVICING</b>	<b>9</b>
2.1	Proposed Water Servicing	9
2.2	Design Criteria	9
2.3	Calculations and Simulation Results	10
2.3.1	Fire Demand	10
2.3.2	Water Demand	11
2.4	Fire Protection	12
2.5	Summary and Conclusions	12
<b>3.0</b>	<b>SANITARY SERVICING</b>	<b>12</b>
3.1	Proposed Sanitary Servicing	12
3.2	Design Criteria	13
3.3	Calculations and Results	13
3.4	Summary and Conclusions	14
<b>4.0</b>	<b>STORM SERVICING AND STORMWATER MANAGEMENT</b>	<b>14</b>
4.1	Existing Storm Servicing	14
4.2	Proposed Storm Servicing	14
4.3	Design Criteria	14
4.4	Allowable Release Rate	15
4.5	Stormwater Management	16

<b>4.6</b>	Stormwater Quality.....	16
<b>4.7</b>	Major Overland Flow .....	16
<b>4.8</b>	Summary and Conclusions .....	16
<b>5.0</b>	<b>SEDIMENT AND EROSION CONTROL .....</b>	<b>17</b>
<b>6.0</b>	<b>CONCLUSION.....</b>	<b>17</b>

**List of Tables**

Table 1: Proposed Building Breakdown .....	1
Table 2: Recommended Pavement Structure – Car Only Parking Areas .....	6
Table 3: Recommended Pavement Structure - Access Lanes and Heavy Truck Parking Areas .....	6
Table 4: Water System Pressure Criteria .....	9
Table 5: Boundary Conditions – 406mm Diameter Watermain on Nicholas Street.....	10
Table 6: Estimated Water Demands.....	12
Table 7: Residual Pressure Under Each Demand with a 150mm Service .....	12
Table 8: Sanitary Design Flow Criteria.....	13
Table 9: Runoff Coefficients.....	15

**List of Figures**

Figure 1: CF Rideau Centre Registry Site .....	2
Figure 2: Existing Municipal Infrastructure Surrounding the Site.....	3

**Appendices**

- APPENDIX A | CORRESPONDENCE
- APPENDIX B | SERVICING CHECKLIST
- APPENDIX C | DRAWINGS
- APPENDIX D | BOUNDARY CONDITIONS
- APPENDIX E | WATER CALCULATIONS
- APPENDIX F | SANITARY CALCULATIONS
- APPENDIX G | STORM CALCULATIONS & DRAINAGE PLANS

## 1.0 INTRODUCTION

### 1.1 Site Description and Proposed Development

The Cadillac Fairview Corporation Limited has retained Parsons Incorporated to prepare a Site Servicing and Stormwater Management Report in support of a combined rezoning and site plan application for a new multi-unit residential rental building at southwest corner of the Nicholas Street and Daly Avenue intersection. The location of the site is shown in **Figure 1**.

The site is currently zoned as mixed-use downtown (MD) [1425] S55, 56, 57, 64, Mature Neighbourhoods Overlay.

The existing access, on Nicholas Street between Daly Avenue and the Mackenzie King Bridge, to the below grade mall parking and at grade loading docks will remain. A passenger pick up/drop off and ramp to below grade parking will be added off of Nicholas Street to service the proposed building. The proposed below grade parking will consist of two (2) levels. An interior bike storage room on the ground floor level of the proposed building will provide approximately one hundred and ninety-three (193)-bicycle parking spots.

The existing City Registry Office will be removed and relocated within the site to accommodate the new building.

The proposed building breakdown is provided in **Table 1**. There will be approximately two hundred and eighty-seven (287) residential units on floors three (3) through twenty-one (21). There will be amenity space on floors one (1) through three (3) and the roof top of the north tower. A mechanical penthouse will be on floor twenty-one (21) of the south tower.

**Table 1: Proposed Building Breakdown**

CF Rideau Centre Registry Site (21 Storeys)	Area (m <sup>2</sup> )
Gross Floor Area (Below Grade)	4,850 m <sup>2</sup>
Gross Floor Area (Above Grade)	19,795 m <sup>2</sup>

The site is approximately 0.27ha and the ground elevation of the site is approximately between 68m and 66m and drains north towards the Nicholas Street and Daly Avenue intersection.

The CF Rideau Centre Registry Site property is surrounded by the features described below:

- North: Rideau Centre Red Parking Garage
- East: The Ottawa Fringe and The Ottawa Jail Hostel
- South: Mackenzie King Bridge
- West: Nordstrom Building



Figure 1: CF Rideau Centre Registry Site

## 1.2 Design Guidelines

The CF Rideau Centre Registry Site design is in accordance with the documents below.

- *Ottawa Design Guidelines – Water Distribution*, 1<sup>st</sup> Edition, July 2010 (OWG and technical bulletins)
  - *Technical Bulletin ISD-2010-2*, December 15, 2010
  - *Technical Bulletin ISDTB-2014-02*, May 27, 2014
  - *Technical Bulletin ISTB-2018-02*, March 21, 2018
  - *Technical Bulletin ISTB-2021-03*, August 18, 2021
- *Sewer Design Guidelines*, City of Ottawa, 2<sup>nd</sup> Edition, October 2012 (OSG and technical bulletins)
  - *Technical Bulletin ISDTB-2012-6*, October 31, 2012
  - *Technical Bulletin ISDTB-2014-01*, February 5, 2014
  - *Technical Bulletin PIEDTB-2016-01*, September 6, 2016
  - *Technical Bulletin ISTB-2018-01*, March 21, 2018
  - *Technical Bulletin ISTB-2019-02*, July 8, 2019
  - *Technical Bulletin ISTB-2021-01*, May 11., 2021
- *Water Supply for Public Fire Protection*, Fire Underwrites Survey, 1999 (FUS)
- *City of Ottawa Park and Pathway Development Manual (2017)*
- *City of Ottawa Accessibility Design Standards (2015)*
- *Ottawa Standard Tender Documents (2021)*
- *Ontario Provincial Standards for Roads & Public Works (2019)*
- *Ontario Building Code (2017)*

### 1.3 Existing Infrastructure

The existing site is currently undeveloped and is not serviced by municipal infrastructure. The existing infrastructure surrounding the property is shown in **Figure 2**.

The existing infrastructure on Nicholas Street consists of:

- 406mm diameter ductile iron watermain (1977)
- 525mm diameter concrete sanitary sewer (1950)
- 675mm diameter reinforced concrete storm sewer (1982)

The existing infrastructure on Daly Avenue consists of:

- 400mm diameter private ductile iron watermain (1977)
- 300mm diameter municipal reinforced concrete sanitary sewer (1994)
- 600mm diameter municipal polyvinyl chloride storm sewer (1994)



Figure 2: Existing Municipal Infrastructure Surrounding the Site

### 1.4 Consultations and Permits

The City of Ottawa and agencies were consulted for this project. A summary of the consultations is provided below; copies of the correspondences and/or minutes are provided in **APPENDIX A**.

### 1.4.1 Consultations

#### City of Ottawa

The City of Ottawa provided the following servicing criteria for the proposed development:

- The allowable release rate (storm and sanitary) will be the 5-year pre-development rate;
- Runoff coefficient will need to be determined based on existing conditions but be no more than 0.5;
- Any storm events greater than 5-year, up to 100-year, and including the 100-year storm event must be detained on site;
- A second drinking water service to be provided where the average daily demand exceeds 50 m<sup>3</sup>/day;

#### Rideau Valley Conservation Authority (RVCA)

Parsons contacted the RVCA who indicated that no water quality control requirements will be required for the proposed development. The implementation of best management practices is encouraged where possible. The communication with the RVCA is included in **APPENDIX A**.

#### Ministry of the Environment, Conservation and Parks (MECP)

An Environmental Compliance Approval (ECA) is not required since its one (1) parcel of land with one (1) owner, one (1) set of services will be provided to the parcel, the land is not zoned as industrial, and the municipal infrastructure within the area is fully separated.

### 1.4.2 Permits and Approvals

The City of Ottawa and the various agencies consulted require the approvals and permits listed below. The City of Ottawa Development Servicing Study Checklist is included in **APPENDIX B**.

#### City of Ottawa

- Road Cut Permit
- Commence Work Order
- Water Permit
- Water Data Card
- Flow Control Roof Drainage Declaration

## 1.5 Geotechnical Recommendations

Paterson Group completed a geotechnical report, *Geotechnical Investigation, 70 Nicholas Street – Ottawa, Ontario*. The report is submitted separately.

The report's recommendations regarding grading, site servicing, and drainage are described below. These recommendations are integrated in the design.

### 1.5.1 Site Grading and Preparation

#### Stripping Depth

- All existing overburden material will be excavated from within the proposed building footprint; and
- Topsoil and fill, containing deleterious materials, should be stripped from under any buildings, paved areas, pipe bedding, and other settlement sensitive structures.

### Bedrock Removal

- Line-drilling in conjunction with hoe-ramming or controlled blasting may be required to remove the bedrock. In areas where only a small quantity of bedrock is to be removed, bedrock removal may be possible by hoe-ramming;
- The effects on the existing services, buildings, and other structures should be addressed prior to considering blasting operations. Should blasting be required, a pre-blast or pre-construction survey of the existing structures located in proximity of the blasting operations should be carried out prior to commencing site activities;
- Peak particle velocity should not exceed 25 mm/s during the blasting program to reduce the risks of damage to the existing structures;
- The blasting operations should be planned and conducted under the supervision of a licensed professional engineer who is an experienced blasting consultant; and
- Excavation side slopes in sound bedrock could be completed with almost vertical side walls. A minimum of 1m horizontal bench should remain between the bottom of the overburden and the top of the bedrock surface to provide an area for potential sloughing or a stable base for the overburden shoring system.

### Vibration Considerations

- Means to reduce vibrations levels caused by construction operations should be incorporated in the construction operations as much as possible. Vibrations caused by blasting or construction operations could cause detrimental vibrations on the adjoining buildings and structures. Recommended that all vibrations be limited;
- As a guideline, the peak particle velocity should be less than 15mm/s between frequencies of 4Hz to 12Hz, and 500mm/s above a frequency of 40Hz (interpolate between 12Hz and 40Hz);
- These guidelines are perceptible at a human level and can be disturbing to some people. Considering there are several sensitive buildings in close proximity to the subject site, consideration to lower these guidelines is recommended; and
- Recommended to carry out a pre-construction survey to minimize the risks of claims during or following construction.

### Bedrock Excavation Face Reinforcement

- A bedrock stabilization system may be required at specific locations to prevent pop outs and will need to be evaluated during the excavation operations.

### Fill Placement

- Fill used for grading beneath the building areas should consist, unless otherwise specified, of clean imported granular fill, such as OPSS Granular A or Granular B Type II;
- Fill should be placed in lifts no greater than 300mm thick and compacted using suitable compaction equipment for the lift thickness;
- Non-specified existing fill along with site-excavated soil can be used as general landscaping fill where settlement of the ground surface is of minor concern;
- Non-specified existing fill should be spread in thin lifts and at least compacted by the tracks of the spreading equipment to minimize voids;
- If non-specified existing fill is to be used to build up the subgrade level for areas to be paved, they should be compacted in thin lifts to a minimum density of 95% of their respective SPMDD;
- Non-specified existing fill and site-excavated soils are not suitable for use as backfill against foundation walls unless a composite drainage blanket connected to a perimeter drainage system is provided; and
- Excavated rock can be used as fill but it should be suitably fragmented to produce a well-graded material with a maximum particle size of 300mm. This material should only be used to build up the subgrade for

pavements. If the fill is open-graded, a binding layer of finer granular fill and/or a woven geotextile may be required.

### 1.5.2 Pavement Structure

#### Lower Parking Level

- Category C2, 32 MPa concrete at 28 days with air entrainment of 5 to 8%; and
- Saw cuts should be used to create control joints within the concrete floor slab. Control joints should be located at the center of the column lines and spaced at approximately 24 to 36 times the slab thickness. Joints should be cut between 25% and 30% of the concrete floor slab thickness and should be completed as early as 4 hours after the concrete has been poured up to 12 hours.

The recommended pavement structure for the lower parking level is shown in **Table 2**.

**Table 2: Recommended Pavement Structure – Car Only Parking Areas**

Thickness (mm)	Material Description
150	32 MPa Concrete
300	BASE – OPSS Granular A Crushed Stone
SUBGRADE – Fill or OPSS Granular B Type I or II material placed over bedrock	

#### Access Lanes and Heavy Loading Parking Areas

- Minimum Performance Graded (PG) 58-34 asphalt cement should be used for this project;
- If soft spots develop in the subgrade during compaction or due to construction traffic, the affected areas should be excavated and replaced with OPSS Granular B Type II material; and
- The pavement granular base and subbase should be placed in maximum 300 mm thick lifts and compacted to a minimum of 98% of the material’s SPMD using suitable vibratory equipment.

The recommended pavement structure for access lanes and heavy loading parking areas is shown in **Table 3**.

**Table 3: Recommended Pavement Structure - Access Lanes and Heavy Truck Parking Areas**

Thickness (mm)	Material Description
40	WEAR COURSE – Superpave 12.5 Asphaltic Concrete
50	BINDER COURSE – Superpave 19.0 Asphaltic Concrete
150	BASE – OPSS Granular A Crushed Stone
300	SUBBASE – OPSS – Granular B Type II
SUBGRADE – OPSS Granular B Type II overlaying the Concrete Podium Deck	

### 1.5.3 Foundation Drainage and Backfill

#### Water Suppression System and Foundation Drainage

- A temporary shoring system and/or bedrock vertical faces should be prepared to receive a waterproofing membrane;
- Waterproofing membrane shall be applied to the temporary shoring system and prepared vertical bedrock surface from 4m below grade to the founding elevation. The water proofing membrane shall also extend horizontally below the proposed footings a minimum of 600mm away from the face of the excavation;
- Waterproofing membrane shall also be placed along the horizontal surface beneath the perimeter footings; and

- It is recommended that the composite drainage system (such as Miradrain G100N, Delta Drain 6000 or equivalent) extend down to the footing level. It is recommended that 150mm diameter sleeves at 3m centres be cast in the foundation wall at the footing interface to allow the infiltration of water to flow to an interior perimeter drainage pipe. The perimeter drainage pipe should direct water to sump pit(s) within the lower basement area.

#### Underfloor Drainage

- Underfloor drainage will be required to control water infiltration due to groundwater infiltration at the proposed founding elevation;
- Recommend that 150 mm in diameter perforated pipes be placed along the interior perimeter of the foundation wall and one drainage line within each bay; and
- The spacing of the underfloor drainage system should be confirmed at the time of backfilling the floor completing the excavation when water infiltration can be better assessed.

#### Foundation Backfill

- Backfill against foundation walls should be free-draining and non-frost susceptible granular materials; and
- The greater part of the site excavated materials will be frost susceptible and, as such, are not recommended for re-use as backfill against the foundation walls, unless used in conjunction with a drainage geocomposite, such as Miradrain G100N or Delta Drain 6000, connected to the perimeter foundation drainage system. Imported granular materials, such as clean sand or OPSS Granular B Type I granular material, should otherwise be used for this purpose.

### **1.5.4 Excavation Side Slopes**

#### Unsupported Side Slopes

- The excavation side slopes above the groundwater level extending to a maximum depth of 3m should be cut back at 1H:1V or flatter. The flatter slope is required for excavation below groundwater level;
- Vertical side slopes can be used in bedrock provided that all loose rock and blocks with weak planes are removed and/or stabilized;
- Excavated soil should not be stockpiled directly at the top of excavations and heavy equipment should maintain safe working distance from the excavation sides;
- Slopes in excess of 3 m in height should be periodically inspected by the geotechnical consultant in order to detect if the slopes are exhibiting signs of distress; and
- A trench box is recommended to protect personnel working in trenches with steep or vertical sides. Services are expected to be installed by “cut and cover” methods and excavations should not remain open for extended periods of time.

#### Temporary Shoring

- Temporary shoring may be required for the overburden soil to complete the required excavations where insufficient room is available for open cut methods.
- The shoring requirements will depend on the depth of the excavation, the proximity of the adjacent buildings and underground structures and the elevation of the adjacent building foundations and underground services; and
- The design and approval of the shoring system will be the responsibility of the shoring contractor and the shoring designer hired by the shoring contractor.

### 1.5.5 Pipe Bedding and Backfill

- A minimum of 150mm of OPSS Granular A should be placed for bedding for sewer or water pipes when placed on soil subgrade. The bedding should extend to the spring line of the pipe. Cover material, from the spring line to a minimum of 300mm above the obvert of the pipe should consist of OPSS Granular A (concrete or PSM PVC pipes) or sand (concrete pipe). The bedding and cover materials should be placed in maximum 225 mm thick lifts and compacted to 95% of the material's SPMDD;
- The re-use of the upper portion of the dry to moist silty clay/glacial till should be possible if the excavation and filling operations are carried out in dry weather conditions. Any stones greater than 200mm in their longest dimensions should be removed prior to use; and
- Where hard surface areas are considered above the trench backfill, the trench backfill material within the frost zone (about 1.8m below finished grade) should match the soils exposed at the trench walls to reduce the potential differential frost heaving. The trench backfill should be placed in maximum 300 mm thick loose lifts and compacted to a minimum of 95% of the SPMDD.

### 1.5.6 Groundwater Control

#### Groundwater Control for Building Construction

- It is anticipated that groundwater infiltration into the excavations should be low to moderate and controllable using open sumps.

#### Permit to Take Water

- A Ministry of the Environment, Conservation and Parks (MECP) Permit to Take Water (PTTW) may be required for this project if more than 400,000L/day of ground water is to be pumped during construction;
- For typical ground or surface water volumes being pumped during the construction phase, ranging between 50,000 to 400,000 L/day, there is a requirement to register on the Environmental Activity and Sector Registry (EASR);
- If a PTTW is required, an EASR will not be allowed as a temporary dewatering measure while awaiting the MECP review of the PTTW application; and
- The contractor should be prepared to direct water away from all bearing surfaces and subgrades, regardless of the source, to prevent disturbance to the founding medium.

#### Long-Term Groundwater Control

- Any groundwater encountered along the building perimeter or sub-slab drainage system shall be directed to the proposed buildings cistern/sump pump;
- The anticipated long-term groundwater flow should be low (less than 25,000L/day/building). A more accurate estimate can be provided during construction;
- The long-term groundwater flow is anticipated to be controllable using conventional open sumps.

#### Impacts on Neighbouring Properties

- A local groundwater lowering is anticipated under short-term conditions due to the construction of the proposed building;
- Based on the existing groundwater level, the extent of any significant groundwater lowering will take place within a limited range of the proposed building;
- Based on the proximity of neighbouring buildings and minimal zone impacted the groundwater lowering, the proposed development will not negatively impact the neighbouring buildings; and
- No issues are expected in regard to groundwater lowering as a result of the proposed waterproofing installation.

### 1.5.7 Winter Construction

- Precautions must be taken if winter construction is considered for this project. The subsoil conditions at this site mostly consist of frost susceptible materials. In presence of water and freezing conditions, ice could form within the soil mass. Heaving and settlement upon thawing could occur;
- In the event of construction during below zero temperatures, the founding stratum should be protected from freezing temperatures by the use of straw, propane heaters and tarpaulins or other suitable means. In this regard, the base of the excavations should be insulated from sub-zero temperatures immediately upon exposure and until such time as heat is adequately supplied to the building and the footings are protected with sufficient soil cover to prevent freezing at founding level; and
- The trench excavations should be carried out in a manner to avoid the introduction of frozen materials, snow or ice into the trenches. As well, pavement construction is difficult during winter. The subgrade consists of frost susceptible soils which will experience total and differential frost heaving as the work takes place. Also, the introduction of frost, snow or ice into the pavement materials, which is difficult to avoid, could adversely affect the performance of the pavement structure.

## 2.0 WATER SERVICING

### 2.1 Proposed Water Servicing

The proposed building will be serviced with two (2) 150mm diameter water services. The two (2) services will be provided from the existing 406mm diameter watermain on Nicholas Street. The two (2) services will be separated by a proposed isolation valve on the existing Nicholas Street watermain. **Drawing SPA-C101**, in **APPENDIX C**, shows the proposed water services.

### 2.2 Design Criteria

The proposed water servicing network has been designed in general conformance with *City of Ottawa Water Design Guideline* as amended by the *Technical Bulletins*.

The system pressure criteria under normal and various operating conditions are listed in **Table 4**.

**Table 4: Water System Pressure Criteria**

Operating Conditions	Pressure Criteria	
	KPa	psi
<b>Average Daily Demand</b>		
Minimum to Maximum	276-552	40-80
Desirable Range	350-480	50-70
<b>Peak Hourly Demand</b>		
Minimum to Maximum	276-552	40-80
Desirable Range	350-480	50-70
<b>Maximum Daily Demand + Fire Flow</b>		
Minimum	140	20

The City of Ottawa provided the revised watermain boundary conditions (August 29<sup>th</sup>, 2022) for the existing 406mm diameter watermain on Nicholas Street, as shown in **Table 5**. A copy of the correspondence is in **APPENDIX D**.

**Table 5: Boundary Conditions – 406mm Diameter Watermain on Nicholas Street**

Minimum HGL	Maximum HGL	Maximum Day + Fire Flow
106.4m	115.4m	109.4m
57psi	70psi	62psi
396KPa	484KPa	425KPa

\*The associated pressures in psi and kPa are based on a ground elevation at the connection location of 65.96m.

The boundary conditions provided demonstrate that the available pressure ranges from approximately 57psi to 70psi during normal operating conditions.

The fire flow was calculated using the Fire Underwriters Survey (FUS) (2020 Version) with the following parameters:

- Type of construction: Fire Resistive Construction
- Occupancy Type: Limited Combustible
- Sprinkler Protection: Fully Monitored Automatic Sprinkler System from Standard Water Supply

The City of Ottawa Water Design Guideline requires that “Service areas with a basic day demand greater than 50 m<sup>3</sup>/day (about 50 homes) shall be connected with a minimum of two watermains, separated by an isolation valve, to avoid the creation of a vulnerable service area. Individual residential facilities with a basic day demand greater than 50 m<sup>3</sup>/day shall be connected with a minimum of two water services, separated by an isolation valve, to avoid the creation of a vulnerable service area.” Therefore, two (2) new 150mm diameter water services will be provided to the building, both from Nicholas Street. An isolation valve we need to be installed on the existing Nicholas Street watermain between the two (2) services.

The new water service will be installed with a minimum depth of cover of 2.4m where possible. Should there be less than 2.4m cover or separation from an open structure, the pipes will be insulated in accordance with City of Ottawa Standard Drawings W22 and W23.

High pressure is not an issue on this site as the boundary conditions are below 80psi. Therefore, pressure reducing valves will not be required.

## 2.3 Calculations and Simulation Results

### 2.3.1 Fire Demand

The fire flow for the building was calculated using the *Fire Underwriters Survey (FUS) Water Supply for Public Fire Protection 2020*.

The required fire flow is determined by the following formula:

$$F = 220C\sqrt{A}$$

Where,

F = the required fire flow in litres per minute (L/min)

C = coefficient related to the type of construction

= 1.5 for **Type V** Wood Frame Construction

= 0.8 for **Type IV-A** Mass Timber Construction

= 0.9 for **Type IV-B** Mass Timber Construction

= 1.0 for **Type IV-C** Mass Timber Construction

- = 1.5 for **Type IV-D** Mass Timber Construction
- = 1.0 for **Type III** Ordinary Construction
- = 0.8 for **Type II** Non-Combustible Construction
- = 0.6 for **Type I** Fire Resistive Construction

A = total effective area is the largest floor area in square metres plus the following percentages of the total area of the other floors:

- Building classified with a Construction Coefficient from 1.0 to 1.5
  - 100% of all floor areas are considered in determining the total effective area to be used in the formula.
- Building classified with a Construction Coefficient below 1.0
  - If any vertical openings in the building are unprotected, consider the two largest adjoining floor areas plus 50% of all floors immediately above them up to the maximum of eight (8).
  - If all vertical openings and exterior vertical communications are properly protected in accordance with the National Building Code, consider only the single largest floor area plus 25% of each of the two (2) immediately adjoining floors.
- Basement floor area is excluded from the total effective area when the basement is at least 50% below grade in the building being considered.

The required fire flow is **67L/s** based on the following parameters, refer to **APPENDIX E** for detailed calculations:

- Construction Coefficient (C)
  - A construction coefficient of **0.6** was selected as the structure will have a fire rating of 2 hours.
- Floor Area (A)
  - The total effective floor area for the parking garage was calculated to be **1,533m<sup>2</sup>** (this includes the largest floor (Level 5) plus 25% of each of the two immediately adjoining floors (Level 4 and Level 6)).
- Occupancy Factor
  - An occupancy factor of **-15% (limited combustible)** was selected for the proposed building.
- Sprinkler Factor
  - An automatic sprinkler system is proposed for the building. FUS allows credits to be added to the fire demands if certain criteria are met. A maximum credit of 30% for adequately designed automatic sprinkler protection systems conforming to NFPA sprinkler standards, an additional credit of up to 10% if the water supply is standard and 10% for full supervision of the sprinkler system.
  - A total reduction factor of **-50%** was applied.
- Exposure Factor
  - A percentage of **+50%** was selected to account for the existing buildings to the north, east, and west of the proposed building. The maximum exposure factor was applied since the structure type and sprinkler protection is unknown for the existing exposed buildings.

### 2.3.2 Water Demand

The anticipated maximum water demand for the proposed building is summarized in **Table 6**. Detailed calculations for the water demand are in **APPENDIX E**. The calculations represent the demand from the 287 units proposed and the retail space on the first floor. A tenant(s) for the retail space is unknown at this time. Given the outdoor courtyards around the building that can be used as patios, it is envisioned that a restaurant or cafe is a potential tenant(s). As restaurant water demand is considerably higher than general retail demand, we have assumed all retail space will be occupied by a restaurant to be conservative.

**Table 6: Estimated Water Demands**

Building	Average Day Demand (ADD) L/s	Maximum Daily Demand (MDD) L/s	Peak Hourly Demand (PHD) L/s	Fire Flow Demand (FF) L/s	MDD + FF L/s
Rideau	2.4	7.2	10.7	67	74.2

The pressures were determined for the average day demand (ADD), maximum daily demand plus fire flow (MDD+FF), and peak hourly demand (PHD) based on the boundary conditions provided by the City of Ottawa using the Hazen-Williams head loss calculations. The calculations are provided in **APPENDIX E**. A 150mm diameter service has been proposed, the resultant pressures are shown in **Table 7**.

**Table 7: Residual Pressure Under Each Demand with a 150mm Service**

	Average Day			PEAK HOUR			Max Day + Fire Flow*		
	(m)	(psi)	(kPa)	(m)	(psi)	(kPa)	(m)	(psi)	(kPa)
Rideau - Nicholas Street Connection	40	57	393	40	57	393	42	59	406

## 2.4 Fire Protection

The available fire flow for the existing fire hydrants within 150m of the building were identified based on the boundary conditions received from the City of Ottawa. In total, two (4) hydrants were determined to be within 150m of the building, based on the travel path of the fire hose from the hydrant to the building. The hydrant locations and the length of the hose travel path are presented in **Figure C**, included in **Appendix E**.

One (1) existing hydrant is located on Nicholas Street, within 150m of the proposed building, and has a maximum flow contribution of 63L/s (at a pressure of 20psi). One (1) existing hydrant is located on Daly Avenue, within 150m of the proposed building, and has a maximum flow contribution of 63L/s (at a pressure of 20psi). Two (2) existing hydrants are located on Nicholas Street, within 75m of the proposed building, and have a maximum flow contribution of 95L/s (at a pressure of 20psi). The maximum flow contributions were obtained from *Table 1- Maximum Flow to be Considered for a Given Hydrant* within *Technical Bulletin ISTB-2018-02*. As a result, a total of **316L/s** is available from the existing contributing hydrants.

The estimated fire demand of **67L/s**, using the *Fire Underwriters Survey Water Supply for Public Fire Protection 2020*, can be provided from the four (4) existing hydrants.

## 2.5 Summary and Conclusions

A 150mm diameter water service is required to supply the proposed building. A second 150mm diameter water service will be provided to ensure redundancy as per the City's Guidelines. The two (2) proposed services will be separated by proposed isolation valve on Nicholas Street.

The water pressures, under average day demand, peak hour demand and maximum day plus fire flow demand are within the allowable pressure range specified by the City of Ottawa.

The estimated fire demand can be provided through the four (4) existing fire hydrants.

## 3.0 SANITARY SERVICING

### 3.1 Proposed Sanitary Servicing

A 150mm diameter sanitary service is proposed from the building to the existing 525mm diameter concrete sanitary sewer within Nicholas Street. An interior sanitary sampling port will be provided and will be coordinated with the Mechanical Consultant to determine the final location. **Drawing SPA-C101**, in **APPENDIX C**, shows the proposed sanitary service.

### 3.2 Design Criteria

The proposed sanitary sewer system has been designed in general conformance with the *City of Ottawa Sewer Design Guideline* as amended by the *Technical Bulletins*.

The sanitary design flow rate is the peak flow plus the peak extraneous flow. The values for the average flow, peak factor, and peak extraneous flow used in the sanitary servicing calculations for the mixed-use development are presented in **Table 8**.

**Table 8: Sanitary Design Flow Criteria**

Development Type	Average Sanitary Flow	Unit	Peak Factor	Peak Extraneous Flow
Residential	280	L/c/d	Harmon Equation	0.33 L/s/gross ha
Amenity	5	L/m <sup>2</sup> /d	1.0/1.5	
Commercial	8.06	L/m <sup>2</sup> /d	1.0/1.5	
Restaurant	125	L/seat/day	1.0/1.5	

The sanitary service is designed with a pipe roughness coefficient of 0.013.

The proposed service will be installed with a minimum cover of 2.0m, where this is not possible insulation will be provided.

The City of Ottawa advised that there are no capacity concerns with the existing sanitary sewers surrounding the site.

### 3.3 Calculations and Results

The proposed development consists of mainly residential space, with retail space on the first floor. A tenant(s) for the retail space is unknown at this time. Given the outdoor courtyards around the building that can be used as patios, it is envisioned that a restaurant or cafe is a potential tenant(s). As sanitary flows from restaurants are considerably higher than those for general retail, we have assumed the worst-case scenario that all retail space will be occupied by a restaurant to be conservative. The resultant peak flow, including extraneous flows, from the subject site is estimated to be **6.8L/s**, the sanitary design flows and sewer pipe design spreadsheets are included in **APPENDIX F**. A 150mm diameter sanitary service with a slope of 2% will be provided from the building to the existing sanitary sewer within Nicholas Street.

There will be additional sanitary flows from the parking garage sump which will collect the drains from the parking garage for snow melt off cars, etc. The discharge rate from the sump pump is not known at this time, as it will be designed by the mechanical engineers, but is expected to be negligible compared to the sanitary flows from the domestic use.

As the groundwater has not yet been proven to be in compliance with MECP Table 7 Standards, it is assumed that the foundation drain will be directed to a sump and through a treatment process before it is pumped to the sanitary service. The sump, treatment and pump will be designed by the mechanical engineers. Following site remediation and additional sampling, if it is demonstrated that the groundwater quality is acceptable for discharge to the storm sewer based on the City's sewer use by-law then the foundation drain will be directed to the storm sewer.

The City of Ottawa advised that there are no capacity concerns with the existing sanitary sewers surrounding the site.

### 3.4 Summary and Conclusions

---

A 150mm diameter sanitary service is proposed from the building to the existing 525mm diameter concrete sanitary sewer within Nicholas Street. An interior sanitary sampling port will be provided and will be coordinated with the Mechanical Consultant to determine the final location.

The City of Ottawa advised that there are no capacity concerns with the existing sanitary sewers surrounding the site.

A backflow preventer will be required for the proposed building.

## 4.0 STORM SERVICING AND STORMWATER MANAGEMENT

### 4.1 Existing Storm Servicing

---

The existing site has a drain on the west side that drains a small area (EWS-C), near the Nordstrom entrance doors. It is assumed that this area drains into the mall plumbing system. There is a catchbasin in the middle of the site that drain a large portion of the grassed area (EWS-A). It is assumed that this area drains into the existing storm sewer within Nicholas Street. The northern portion of the site (ESW-B) drains through surface flow.

The site generally drains southwest to northeast towards the intersection of Nicholas Street and Daly Avenue. The topography of the site is fairly flat with slopes between 3% and 7%.

The existing drainage area for the site is illustrated in **Figure A**, included in **APPENDIX G**.

### 4.2 Proposed Storm Servicing

---

A 200mm diameter storm service is proposed from the building to the existing 600mm diameter polyvinyl chloride storm sewer within Daly Avenue. **Drawing SPA-C101**, in **APPENDIX C**, shows the proposed storm service.

All rooftop surfaces will drain through uncontrolled roof drains. These flows will be directed to the cistern within the underground parking garage. A portion of the front entrance will drain through uncontrolled trench drains. These flows will be directed to the cistern within the underground parking garage. The remaining portion of the front entrance will sheet drain to Nicholas Street.

The design approach for the stormwater management is to ensure that the post-development peak flows do not exceed the existing 5-year pre-development release rate flow.

The post-development drainage areas are illustrated in **Figure B**, included in **APPENDIX G**.

### 4.3 Design Criteria

---

The proposed storm sewer system has been designed in general conformance with the *City of Ottawa Sewer Design Guideline* as amended by the *Technical Bulletins*.

It's assumed that there are no capacity concerns with the existing storm sewers surrounding the site unless otherwise noted by the City of Ottawa.

The *City of Ottawa Sewer Design Guideline* addresses stormwater for infill developments in *Section 8.3.7.2* and for commercial/institutional and industrial site plans in *Section 8.3.7.3*.

The design criteria include the following:

- In the absence of a subdivision master servicing study, or if there is an increase in the site's overall runoff coefficient, the designer must ensure that there will be no adverse impact to the existing storm system;
- On-site stormwater management measures may be required if the existing system is at or near capacity;

- For commercial/institutional and industrial site plans, the runoff must be controlled to the 2-year or 5-year pre-development level depending on the design return period of the receiving sewer, and all flow depth must be controlled on-site; and
- For commercial/institutional and industrial site plans, in the case of a site re-development, over-controlling may be required if the capacity of the receiving sewer is in question. In such a case the pre-development condition will be determined using the smaller of a runoff coefficient of 0.5 or the actual existing site runoff coefficient.

In order to ensure no adverse impacts to the existing storm system, there will be no increase to the existing storm flows from the site. Given that this is a mixed-use development, the runoff will be controlled to the 5-year storm pre-development flow using the existing runoff coefficient for the site. The existing runoff coefficient is proposed as it is our understanding there is no capacity concerns with the receiving sewer. The 5-year storm was selected based on the storm service connection being proposed on Nicholas Street which is a collector street and therefore the sewer would be sized for 5-year flows. The flows to the storm sewer in excess of the 5-year storm release rate, up to and including the 100-year storm event, will be detained on site.

The Rational Method is used to calculate the allowable peak flow.

IDF curve equations used with the Rational formula:

- 5-year =  $998.071 / (T_c + 6.053)^{0.814}$
- 100-year =  $1735.688 / (T_c + 6.014)^{0.820}$

The Rational Method uses runoff coefficients for various surfaces. The runoff coefficients used for the proposed development are shown in **Table 9**. The runoff coefficient for a 100-year storm event is increased by 25% per the *City of Ottawa Sewer Design Guideline* to a maximum of 1.0.

**Table 9: Runoff Coefficients**

Surface	5-Year Coefficient	100-Year Coefficient
Asphalt/Building/Concrete	0.90	1.00
Gravel	0.70	0.88
Grass	0.20	0.25

The proposed service will be installed with a minimum cover of 2.0m, where this is not possible insulation will be provided.

It's assumed that there are no capacity concerns with the existing storm sewers surrounding the site unless otherwise noted by the City of Ottawa.

#### 4.4 Allowable Release Rate

The allowable release rate for the 0.27ha site was calculated using the rational method formula based on the 5-year flow and the existing runoff coefficient of 0.35.

$$Q = 2.78 CiA$$

where

Q = Flow rate (L/s)

C = Runoff coefficient

i = Rainfall intensity (mm/hr)

A = Area (ha)

The resultant allowable release rate is **27.2L/s**.

#### 4.5 Stormwater Management

---

The on-site storm water management has been designed to attenuate the 5-year and 100-year post-development flow rates to the pre-development 5-year flow rate as shown in the stormwater calculations included in **APPENDIX G** and summarized below.

##### **DRAINAGE AREAS WS-01 TO WS-06 (UNCONTROLLED ROOF DRAINS TO CISTERN)**

All rooftop surfaces will drain through uncontrolled roof drains. These flows will be directed to the cistern within the underground parking garage.

##### **DRAINAGE AREAS WS-07 AND WS-08 (UNCONTROLLED FRONT ENTRANCE TO CISTERN)**

The front entrance along Nicholas Street will consist of a patio area with landscape features and an entrance and exit to the underground parking garage. This portion of the front entrance will drain through uncontrolled trench drains. These flows will be directed to the cistern within the underground parking garage.

The flows from drainage areas WS-01, WS-02, WS-03, WS-04, WS-05, WS-06, WS-07, AND WS-08 will be directed to the cistern. The stormwater storage tank will be pumped to the proposed storm service at a maximum allowable flow rate of **9.9L/s**. The required storage volume of the cistern is 46m<sup>3</sup> and 111m<sup>3</sup> during the 5-year and 100-year storms, respectively. As per the *City of Ottawa Sewer Design Guideline*, the cistern is being sized to accommodate the 100-year storm plus a 20% stress test which results in a required volume of **142m<sup>3</sup>**.

##### **DRAINAGE AREA WS-09 AND WS-10 (UNCONTROLLED FRONT ENTRANCE) Rideau**

The front entrance along Nicholas Street will consist of a patio area with landscape features and an entrance and exit to the underground parking garage. This portion of the front entrance will sheet drain to Nicholas Street.

The combined uncontrolled flow from these drainage areas will be **8.2L/s** for the 5-year event and **17.3L/s** for the 100-year event.

#### 4.6 Stormwater Quality

---

The RVCA has indicated that onsite water quality treatment will not be required for the site.

#### 4.7 Major Overland Flow

---

The major overland flow routes are to Nicholas Street and Daly Avenue.

#### 4.8 Summary and Conclusions

---

A 200mm diameter storm service is proposed from the building to the existing 600mm diameter polyvinyl chloride storm sewer within Daly Avenue.

No ponding on the surface is planned for the site. All stormwater is being controlled within the cistern located in the underground parking garage, including the volumes for the 100-year storm plus a 20% stress test.

The stormwater flows are controlled with the post-development 100-year flows being controlled to the pre-development 5-year rate.

It's assumed that there are no capacity concerns with the existing storm sewers surrounding the site unless otherwise noted by the City of Ottawa.

## 5.0 SEDIMENT AND EROSION CONTROL

To mitigate the impacts due to erosion and sedimentation during construction, erosion and sediment control measures shall be installed and maintained throughout the duration of construction. Measures shall only be removed once the construction activities are complete, and the site has stabilized.

The measures will include:

- Siltsack® shall be installed between the frame and cover of existing and new catchbasins and maintenance holes, to minimize sediments entering the storm drainage system. These shall remain in place until construction is complete;
- A mud mat shall be provided where equipment will be leaving the site; and
- Light Duty Silt Fence Barriers shall be placed along the north border of the site. The barriers shall be installed and maintained according to OPSS 577 and OPSD 219.110.
- A visual inspection shall be completed daily to identify any erosion and sediment control measures that may require repair;
- Erosion and sediment control measures shall be cleaned as required; and
- Additional erosion and sediment control measures may need to be installed by the Contractor during construction as requested by the Engineer.

## 6.0 CONCLUSION

This report outlines the proposed servicing and stormwater management design for the proposed building.

A 150mm diameter water service is required to supply the proposed building. A second 150mm diameter water service will be provided to ensure redundancy. The two (2) proposed services will be separated by a proposed isolation valve on the existing Nicholas Street watermain.

A 150mm diameter sanitary service is proposed from the building to the existing 525mm diameter concrete sanitary sewer within Nicholas Street. The City of Ottawa advised that there are no capacity concerns with the existing sanitary sewers surrounding the site. An interior sanitary sampling port will be provided and will be coordinated with the Mechanical Consultant to determine the final location.

A 200mm diameter storm service is proposed from the building to the existing 600mm diameter polyvinyl chloride storm sewer within Daly Avenue. The uncontrolled flows from all roof surfaces and a portion of the front entrance will be directed to a 142m<sup>3</sup> cistern to be located within the underground parking garage. The flows in the cistern will be pumped to the proposed storm service at a maximum allowable rate of 9.9L/s. The remaining portion of the front entrance will sheet flow to Nicolas Street. The stormwater runoff from the proposed site for the 100-year event will be controlled to the pre-development 5-year flow of 27.2L/s

Prepared by:

Reviewed by:



A handwritten signature in black ink, appearing to read "K. Paradis".

Sarah Mitchelson, P.Eng.

Kelly Paradis, P.Eng., PMP

H:\ISO\477846\1000\DOCS\3 - Site Servicing Report\Rideau Site Servicing and Stormwater Report REV3.docx

## APPENDIX A | CORRESPONDENCE

## **Pre-Application Consultation Meeting Notes**

**70 Nicholas Street May 12, 2021  
PC2021-0155  
TEAMS software**

### **Attendees:**

Simon Deiaco, City of Ottawa, Planning (SD)  
Randolph Wang, City of Ottawa, Urban Design (RW)  
Luis Juarez, City of Ottawa, Heritage (LJ)  
John Wu, City of Ottawa, Engineering (JW)  
John Verbaas, Action Sandy Hill (JV)  
Doug James, City of Ottawa, Manager Development Review (DJ)  
Peter Nikolakakos, Cadillac Fairview (PN)  
Aaron Cameron, Cadillac Fairview (AC)  
Brian Salpeter, Cadillac Fairview (BS)  
Matthew Lausberg, Cadillac Fairview (ML)  
Viadila Banelis, Zeidler (VB)  
Queenie Wong, Zeidler (QW)  
Matthew Mantle, Parsons (MM)  
Chris Ilg (CI)  
Barry Padolsky, Architect CSV (BP)  
Jerrold Corsh, CSW Landscape Architects (JC)

### **Regrets:**

Mike Giampa, City of Ottawa, Transportation (MG), comment provided.

### **Subject: 70 Nicholas Street (Registry Site)**

### **Meeting notes:**

#### Opening & attendee introduction

- Introduction of meeting attendees
- Overview of proposal:
  - BS – core strategies, densification and diversification
  - As a land owner Cadillac Fairview is considerate of creating connected and vibrant communities, place making and quality design.
  - Cadillac Fairview own and operate their properties and understand the importance of placemaking.
  - PN – focus is on the registry site. Rights and obligations over the site with certain tenants that impacts design and function.
  - Architectural details have yet to be fully developed. Barry Padolsky is assisting with the strategy to address the registry building which has not yet been finalized.
  - Would like to understand process and timing of the project

- (VB) 300-350 units, approx. 300,000 sq.ft. above grade, bike parking at .5 and 1/3 parking stalls – 2 levels of below grade parking.
- Project is proposing to move the Registry Building, use it to frame the new project
- Need to maintain and keep operational access to the blue garage and realign/tighten the loading dock.
- Working on methodologies to relocate the Registry Building, no specific approach has been determined to date.
- Approx. 1.5-2m grade change from sidewalk to entrance of the mall, air intake vents that need to be managed in the design.
- In the massing approach the team appreciates the view plane restrictions, volume then sculpted to take advantage of views, reintegrate the Registry Building, pull entrance to the mall.
- Registry Building would frame the residential entrance, attempting to tie the ground plane to the street.
- Existing bus parking on Nicholas that would need to be discussed.
- Have reviewed the public realm plans for the area.

Preliminary comments and questions from staff and agencies, including follow-up actions:

- Planning (SD)

- Zoning MD[1425] S55, 56, 57 and 64, Mature Neighbourhoods overlay.
- Heritage Overlay for the registry building. Designated under Part IV on the OHA.
- Design Priority Area, public realm plan developed as part of the recent expansion.
- Annex 8A – Area of Background Height Control



- Property is located within the Central Area Secondary Plan Area, Section 1.6 Rideau/Congress Centre [LINK](#). Please refer to the applicable policies in preparing the planning rationale.
  - Apartment high-rise is permitted, zoning amendment will have to address the heritage overlay provisions for the site. Staff will need to work with heritage staff if there would be an intent to re-establish the overlay provision after the building is relocated.
- Urban Design (RW)
- Question regarding the tower floor plate – approx. 1,300 sq.m.
  - Question on tenure, Rental project? Correct.
  - Concerns on the configuration of the potential wall of buildings when viewed from the canal.
  - Have other floor plates and tower masses been considered? For example a more compact form that may not require the need for a tower to overhang the registry building.
  - Details will matter on the integration of the registry building, such as 150 Elgin.
  - Subject to UDRP review, recommends a preconsultation meeting given the file history.
  - A Design Brief (attached) is required as part of the submission. The Terms of Reference is attached for convenience. Please note both wind and shadow studies are required.
  - The property is within the Design Priority Area. The project is subject to the formal review by the City's Urban Design Review Panel (UDRP). Given the complexity of the project a visit to the UDRP for informal preconsultation before the design going any further and a submission to the City is made is highly recommended. Please contact [udrp@ottawa.ca](mailto:udrp@ottawa.ca) to schedule the visit.
  - With respect to the preliminary concept presented at the meeting, the analysis, the thought process, and the complexity of the programming are much appreciated.
  - The podium and public realm
    - The proposed a new atrium of the mall can potentially improve the pedestrian experience along both Daly and the corner of Daly and Nicholas.
    - However, the proposed “port cochere” and the garage ramp combined devote the majority of the Nicholas frontage to vehicular circulation.
    - Significant reconsiderations to the design of the podium and vehicular circulation are required in order to animate Nicholas Street and improve the overall pedestrian experience.
    - The height of the podium should take into consideration of the views and pedestrian experience from both Nicholas and the Mackenzie King Bridge.
    - The new development should make efforts to animate Mackenzie King Bridge by covering the existing parking and loading operations with a new structure, potentially an extended podium.
    - Efforts should also be made to explore pedestrian connection between Nicholas and the Bridge.

- The Tower
  - The City's guidelines for high-rise buildings supports small tower floor plate. The proposed tower floor plate is nearly twice as big as the maximum floor plate the City (750m<sup>2</sup>) the City can support.
  - It is recognized that in this case some impacts of a larger floor plate may be mitigated because of the ample separation spaces available between the proposed tower and the nearby high-rise buildings. A slightly larger floor plate may be supportable if all other issues and considerations are successfully addressed.
  - The proposed wide-spreading "bar" building can have significant impacts on views, including views from the Rideau Canal, quality of public realm, and heritage.
  - A compact floor plate design is highly recommended even if such a design may reduce the separation between the tower and the existing mall. Such a compact floor plate design can have a number of benefits, including views, quality of public realm, and heritage preservation/integration.
- Heritage integration
  - Urban design caution the need for high quality materials and details in the design of the glass curtain wall in order to achieve the vision shown in the preliminary concept.
  - A more compact tower floor plate design that avoids putting a tower over the heritage structure, can be beneficial.
  - The attached diagrams illustrate some of the comments expressed above. Hope these are all helpful.
- Engineering (JW)
  - Services available from Nicholas
  - Possible second water connection needed give the water demands of the site.
  - PB, ask about a stationary noise requirement. JW confirmed is should include this component for the abutting sites.
- Transportation (MG)
  - The application will not be deemed complete until the submission of the draft step 2-4, including the functional draft RMA package (if applicable) and/or monitoring report (if applicable).
  - Although a full review of the TIA Strategy report (Step 4) is not required prior to an application, it is strongly recommended.
  - Synchro files are required at Step 4.
  - ROW protection on Nicholas is 20 m.
  - Corner sight triangle: 5m x 5m
  - Clear throat requirements as per TAC guidelines for an arterial road.
  - Please note that all new applications (pre-consultation meetings dated after March 3, 2021) must use the NEW TRANS Trip Generation Manual when forecasting site generated trips using this manual.
  - The TRANS committee (a joint transportation planning committee serving the National Capital region) finalized a new manual early in March 2021. The document will be available in French and English on the TRANS website <http://www.ncr-trans-rcn.ca/surveys/2009-trip-generation>. The new manual has

simplified the conversion from vehicle trips to person trips and then trips by modal share.

- JC, comment – need to understand the curb line on the street. SD to follow up on right of way requirements (noted above).
- Parks (SD)
  - Cash-in-lieu of parkland/ parkland dedication will be required (payment)
- Heritage (LJ)

### Background

- The City Registry Office (CRO) is situated on the subject-property. It was constructed in 1873 and was designated under Part IV of the *Ontario Heritage Act* in 1978.
- Heritage attributes listed in the [designation by-law](#) include the round headed window and door arches with rusticated quoins, the salmon-gold brick, and the barrel vault ceiling.
- Heritage Overlay provisions in Zoning By-law 2008-250 (Section 60) are applicable to the CRO lands. Variances to the provisions are required to facilitate the proposed development.
- As per the preliminary plans submitted for the Pre-Consultation meeting, the proposed works include the relocation, conservation, and adaptive reuse of the CRO, and the construction of a high-rise residential component to the Rideau Centre.
- A heritage permit application will be required to facilitate this proposal. Based on the information provided at the meeting the following Heritage application types and fees are applicable:
  - 'Council-level authority – Major Alteration': \$8,560.00.
  - Staff will confirm the application type and fee when the proposal is further refined.
- Staff have provided preliminary comments based on the submitted materials. Should additional drawings or details be provided or should the design change, Staff may require further review and may provide additional comments.

### Application Requirements

- [Application Form and Payment](#);
- Cultural Heritage Impact Statement (refer to [guidelines](#) for preparing a CHIS), evaluating the impact of the proposed development on the following heritage resources:
  - The City Registry Office (designated Part IV, located on subject-property)
  - The Albion Hotel (designated Part IV, adjacent to subject-property)
  - The Carleton County Courthouse (designated Part IV, adjacent to subject-property)
  - The Carleton County Gaol (designated Part IV, adjacent to subject-property);
- Conservation Plan (refer to Section 5.0 of the guidelines for preparing CHIS), outlining the conservation approach for the CRO, including an analysis on how

the CRO will be moved, associated risks with relocation, proposed protection measures, and long-term rehabilitation;

- NOTE: an options analysis on how to move the CRO should be prepared and reviewed by staff prior to the submission of a conservation plan. Staff will provide further guidance on the scope of the conservation plan based on the options analysis;
- Detailed description of the proposed work;
- Site plan, inclusive of a zoning compliance chart;
- Landscape plan, inclusive of details for the proposed public plaza in front of the relocated CRO;
- Coloured elevations, measured with materials indicated; and
- Coloured streetscape rendering, demonstrating the relationship between the proposed high-rise and the relocated CRO on the streetscape (Nicholas Street).

### Comments

#### Relocation of CRO

- The relationship between the location of the CRO, the Courthouse and the Gaol provides strong contextual value of a former Ottawa judicial district – any relocation of the CRO shall maintain this relationship.
- If the building is to be relocated, Heritage staff strongly prefer an option that moves the building in its entirety. The dismantling, storage and reconstruction of a building presents significant risks to the historic fabric of the resource.
- The CRO has high architectural integrity – any options that consider the relocation of the CRO structure should prioritize the *Standards and Guidelines for the Conservation of Historic Places in Canada* to ensure that the CRO's architectural integrity, heritage value, and character defining elements are maintained.
- Characteristic of CROs and exemplary in Ottawa's CRO is the solid and fireproof construction methods and materials employed, including brick vaults, cast-iron window fittings, and stone floors used to protect the sanctity of land ownership. Evidence of these construction methods should not be removed if the CRO is relocated.
- A conservation plan will be required to outline the conservation approach for the CRO. The plan shall describe how the CRO will be moved, associated risks, proposed protection measures, and a long-term rehabilitation program.

#### Proposed Development and Integration of the CRO

- Heritage staff are supportive of the development proposal's intention to reactivate the CRO. Please provide details regarding the proposed use as they are made available.
- Ensure that the CRO's proposed use requires minimal or no change to character defining elements and restore exterior and interior elements (i.e. barrel-vaulted ceiling) as part of the proposed works.
- Heritage Staff mirror Urban Design comments related to the refinement of the residential tower's massing in a way that is compatible with the CRO and adjacent heritage resources. When determining how much of the CRO should project onto the street, and how much should be enclosed into the interior of the

new building, ensure that enough of the CRO is “out” so that the building does not just read as a façade.

- Clarify access to the CRO and its relationship with the interior of the new building. The entrance on Nicholas street should continue as the main access to the future use of the CRO. Universal accessibility to the building should be incorporated sensitively.
  - Across the street are three other Part IV designations; the Albion Hotel, the Carleton County Courthouse, and the Carleton County Gaol that together with the CRO formed a nineteenth century judicial district in the City. A CHIS will be required to review the impacts of the proposed development on adjacent heritage resources in addition to the CRO.
- Questions and comments from the Community Association representative (ASH)
    - The team should spend time on the design elements to maximize the benefits of the project. The “experience will be key”
    - Will experience a loss of greenspace.
    - Shadowing impacts will need to be studied.

### **Submission requirements and fees**

### **Next steps**

- Encourage applicant to discuss the proposal with Councillor, community groups and neighbours

## Mitchelson, Sarah

---

**From:** Wu, John <John.Wu@ottawa.ca>  
**Sent:** Thursday, May 13, 2021 1:54 PM  
**To:** Aaron Cameron  
**Cc:** Paradis, Kelly; Mitchelson, Sarah  
**Subject:** [EXTERNAL] RE: 70 Nicholas Street - Servicing Questions

**Follow Up Flag:** Follow up  
**Flag Status:** Completed

Hi, All:

For your questions , please see below comment:

- a. Water on Daily is a private 406mm Ductile Iron - Need to confirm with City that this is a private service. The private service is looped from Nicholas Street to Colonel By Drive. I confirm it is private service.
- b. Water on Nicholas St is a 406mm Ductile Iron - If the water located on Daily is a private service the development will need to connect to Nicholas St, or can the Development connect to the water within Daily St? you need two connection, since the private water main is looped , you better just connected to the private water service.
- c. Sanitary sewer -
  - i. 525mm Conc located on Nicholas (flows north)
  - ii. 300mm Conc located on Daily (flows west) does not connect to sewer in Nichola
  - iii. All above is right. There is no preference for connection.
- d. Storm sewer
  - i. 675mm Conc located on Nicholas flows North (Invert 62.8 +/-) outlet location is summed to be an outfall (OUT10986) to the Ottawa River located behind the National Research Council building along Sussex Drive
  - ii. 600mm PVC located on Daily flows west (Invert 61.1 +/-) outlet is the Ottawa river at the Rideau Canal opening (OUT10549).
  - iii. Better go to Nicholas Storm

Based on the above information provided, the infrastructure located on Daily Ave and Nicholas Street are separate systems. Which system can the development connect to for Water, Sanitary, and Storm sewer.

See answers above/

2. What quality and quantity control measures are required for storm sewers treatment? You need to control to C0.5 or the existing , in this case, I think existing C value, and using 5 year's storm to control up to 100 year's storm. And stormceptor is required for quality control 80% of removal for TSS.
3. Please contact information center for your record information search.
4. We are not sure if there is any capacity issue for down stream, we will circulate your report when the application comes in.

Thanks.

John

---

**From:** Aaron Cameron <aaron.cameron@cadillacfairview.com>  
**Sent:** May 13, 2021 1:12 PM  
**To:** Wu, John <John.Wu@ottawa.ca>  
**Cc:** Paradis, Kelly <Kelly.Paradis@parsons.com>; Mitchelson, Sarah <Sarah.Mitchelson@parsons.com>  
**Subject:** 70 Nicholas Street - Servicing Questions

**CAUTION: This email originated from an External Sender. Please do not click links or open attachments unless you recognize the source.**

**ATTENTION : Ce courriel provient d'un expéditeur externe. Ne cliquez sur aucun lien et n'ouvrez pas de pièce jointe, excepté si vous connaissez l'expéditeur.**

Hi John,

Further to my previous email, see below for clarifications sought by Parsons. I have cc'ed Kelly and Sarah in the event you have any questions for them directly.

1. Is the City aware of any design constraints on the existing City infrastructure located on either Daily Avenue or Nicholas Street.
  - a. Water on Daily is a private 406mm Ductile Iron - Need to confirm with City that this is a private service. The private service is looped from Nicholas Street to Colonel By Drive.
  - b. Water on Nicholas St is a 406mm Ductile Iron - If the water located on Daily is a private service the development will need to connect to Nicholas St, or can the Development connect to the water within Daily St?
  - c. Sanitary sewer -
    - i. 525mm Conc located on Nicholas (flows north)
    - ii. 300mm Conc located on Daily (flows west) does not connect to sewer in Nichola
  - d. Storm sewer
    - i. 675mm Conc located on Nicholas flows North (Invert 62.8 +/-) outlet location is summed to be an outfall (OUT10986) to the Ottawa River located behind the National Research Council building along Sussex Drive
    - ii. 600mm PVC located on Daily flows west (Invert 61.1 +/-) outlet is the Ottawa river at the Rideau Canal opening (OUT10549).
2. Based on the above information provided, the infrastructure located on Daily Ave and Nicholas Street are separate systems. Which system can the development connect to for Water, Sanitary, and Storm sewer.
3. What quality and quantity control measures are required for storm sewers treatment?
4. Parsons has contacted and received as-built information from the City information centre although can the City provide any additional information. Are there any higher-level studies and/or reports

(master servicing studies, environmental assessments, community design plans, etc.) that we need to reference and/or conform to?

5. In addition to the response from #1 and #2 is there available capacity in downstream sewers (storm and sanitary) for the development (Nicholas or Daily)

Thanks,

**AARON CAMERON**

SENIOR MANAGER, PLANNING & ENTITLEMENTS, DEVELOPMENT

The Cadillac Fairview Corporation Limited  
20 Queen St. West,  
Toronto, Ontario  
M5H 3R4

T: (416) 598-8531 M: (416) 566-9200

[aaron.cameron@cadillacfairview.com](mailto:aaron.cameron@cadillacfairview.com)

[cadillacfairview.com](http://cadillacfairview.com) [[can01.safelinks.protection.outlook.com](http://can01.safelinks.protection.outlook.com)]

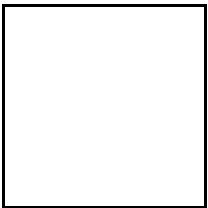
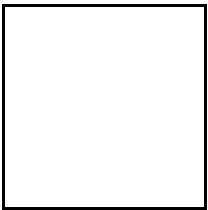

This e-mail originates from the City of Ottawa e-mail system. Any distribution, use or copying of this e-mail or the information it contains by other than the intended recipient(s) is unauthorized. Thank you.

Le présent courriel a été expédié par le système de courriels de la Ville d'Ottawa. Toute distribution, utilisation ou reproduction du courriel ou des renseignements qui s'y trouvent par une personne autre que son destinataire prévu est interdite. Je vous remercie de votre collaboration.

## Mitchelson, Sarah

---

**From:** Eric Lalande <eric.lalande@rvca.ca>  
**Sent:** Tuesday, June 8, 2021 1:48 PM  
**To:** Mitchelson, Sarah  
**Subject:** [EXTERNAL] RE: Rideau Centre Registry Site, Ottawa

Hi Sarah,

The RVCA does not have any quality control requirements for the proposed development. Best management practices are encouraged where possible.

We generally will provide formal comments through the City's review process, but I am not anticipating any concerns.

Thank you,

**Eric Lalande, MCIP, RPP**  
Planner, RVCA  
613-692-3571 x1137

---

**From:** Mitchelson, Sarah <Sarah.Mitchelson@parsons.com>  
**Sent:** Tuesday, June 8, 2021 1:21 PM  
**To:** Eric Lalande <eric.lalande@rvca.ca>  
**Cc:** Paradis, Kelly <Kelly.Paradis@parsons.com>  
**Subject:** Rideau Centre Registry Site, Ottawa

Sensitive

Hi Eric,

We would like to request any RVCA requirements and/or comments related to the proposed Rideau Centre Registry Site.

We are working with the owner of CF Rideau Centre (Cadillac Fairview) towards a Site Plan Approval from the City of Ottawa, for the construction of a multi-unit residential rental building. As you can see from the existing aerial below, the development area consists of grass, a heritage building, and access to the below grade mall parking and loading docks.







Please advise if any further information is required and/or you have any questions/concerns.

Regards,  
Sarah

**SARAH MITCHELSON, P.ENG**

Municipal Engineer

1223 Michael Street North, Suite 100, Ottawa, ON K1J 7T2

[sarah.mitchelson@parsons.com](mailto:sarah.mitchelson@parsons.com)

Direct: +1 613.691.1609 / Mobile: +1 613.698.6705

[Parsons](#) / [LinkedIn \[linkedin.com\]](#) / [Twitter \[twitter.com\]](#) / [Facebook \[facebook.com\]](#) / [Instagram \[instagram.com\]](#)



'NOTICE: This email message and all attachments transmitted with it may contain privileged and confidential information, and information that is protected by, and proprietary to, Parsons Corporation, and is intended solely for the use of the addressee for the specific purpose set forth in this communication. If the reader of this message is not the intended recipient, you are hereby notified that any reading, dissemination, distribution, copying, or other use of this message or its attachments is strictly prohibited, and you should delete this message and all copies and backups thereof. The recipient may not further distribute or use any of the information contained herein without the express written authorization of the sender. If you have received this message in error, or if you have any questions regarding the use of the proprietary information contained therein, please contact the sender of this message immediately, and the sender will provide you with further instructions.'

**APPENDIX B | SERVICING CHECKLIST**

## Development Servicing Study Checklist

1 General Content		Comments
NA	Executive Summary (for larger reports only).	
Y	Date and revision number of the report.	Title Page
Y	Location map and plan showing municipal address, boundary, and layout of proposed development.	Figure 1 & Drawings
Y	Plan showing the site and location of all existing services.	Figure 2 & Drawings
NA	Development statistics, land use, density, adherence to zoning and official plan, and reference to applicable subwatershed and watershed plans that provide context to which individual developments must adhere.	
Y	Summary of Pre-consultation Meetings with City and other approval agencies.	Section 1.4 & Appendix A
NA	Reference and confirm conformance to higher level studies and reports (Master Servicing Studies, Environmental Assessments, Community Design Plans), or in the case where it is not in conformance, the proponent must provide justification and develop a defensible design criteria.	
Y	Statement of objectives and servicing criteria.	Section 2.2/3.2/4.3
Y	Identification of existing and proposed infrastructure available in the immediate area.	Section 1.3
NA	Identification of Environmentally Significant Areas, watercourses and Municipal Drains potentially impacted by the proposed development (Reference can be made to the Natural Heritage Studies, if available).	
Y	Concept level master grading plan to confirm existing and proposed grades in the development. This is required to confirm the feasibility of proposed storm water management and drainage, soil removal and fill constraints, and potential impacts to neighboring properties. This is also required to confirm that the proposed grading will not impede existing major system flow paths.	Drawings
NA	Identification of potential impacts of proposed piped services on private services (such as wells and septic fields on adjacent lands) and mitigation required to address potential impacts.	
NA	Proposed phasing of the development, if applicable	
Y	Reference to geotechnical studies and recommendations concerning servicing.	Section 1.5
	All preliminary and formal site plans submissions should have the following information:	
Y	I Metric Scale	Drawings
Y	I North arrow (including construction North)	Drawings
Y	I Key Plan	Drawings
Y	I Name and contact information of applicant and property owner	Drawings
Y	I Property limits including bearing and dimensions	Drawings
Y	I Existing and proposed structures and parking areas	Drawings
Y	I Easement, road widening and right-of-way	Drawings
Y	I Adjacent street names	Drawings
2 Development Servicing Report : Water		Comments
NA	Confirm consistency with Master Servicing Study, if available.	
Y	Availability of public infrastructure to services proposed development.	Section 2.0
Y	Identification of system constraints.	Section 2.2
Y	Identification of boundary conditions.	Section 2.2
Y	Confirmation of adequate domestic supply and pressure	Section 2.2

<b>Development Servicing Study Checklist</b>		
Y	Confirmation of adequate fire flow protection and confirmation that fire flow is calculated as per the Fire Underwriter's Survey. Output should show available fire flow at locations throughout the development.	Section 2.3 & Appendix E
NA	Provided a check of high pressure. If pressure is found to be high, an assessment is required to confirm the application of pressure reducing valves.	
NA	Definition of phasing constraints. Hydraulic modeling is required to confirm servicing for all defined phases of the project including the ultimate design.	
Y	Address reliability requirements such as appropriate location of shut-off valves.	Section 2.2
NA	Check on the necessity of a pressure zone boundary modification.	
NA	Reference to water supply analysis to show that major infrastructure is capable of delivering sufficient water for the proposed land use. This includes data that shows that expected demands under average day, peak hour and fire flow conditions provide water within the required pressure range.	Section 2.3
Y	Description of the proposed water distribution network, including locations of proposed connections to the existing system, provisions for necessary looping, and appurtenances (valves, pressure reducing valves, valve chambers, and fire hydrants) including special metering provisions.	Section 2.1
NA	Description of off-site required feeder mains, booster pumping stations, and other water infrastructure that will be ultimately required to service proposed development, including financing, interim facilities, and timing of implementation.	
Y	Confirmation that water demands are calculated based on the City of Ottawa Design Guidelines.	Section 2.2
Y	Provision of model schematic showing the boundary conditions locations, streets, parcels, and building locations for reference.	Appendix D
<b>3 Development Servicing Report: Wastewater</b>		<b>Comments</b>
Y	Summary of proposed design criteria (Note: Wet-weather flow criteria should not deviate from the City of Ottawa Sewer Design Guidelines. Monitoring Flow data from relatively new infrastructure cannot be used to justify capacity requirements for proposed infrastructures).	Section 3.0
NA	Confirm consistency with Master Servicing Study and/or justification for deviations.	
NA	Consideration of local conditions that may contribute to extraneous flow that are higher than the recommended flow in the guidelines. This includes groundwater and soil conditions, and age and condition of sewers.	
Y	Description of existing sanitary sewer available for discharge of wastewater from proposed development.	Section 3.1
NA	Verify available capacity in downstream sanitary sewer and/or identification of upgrades necessary to service the proposed development. (Reference can be made to previously completed Master Servicing Study if applicable).	
Y	Calculations related to dry-weather and wet-weather flow rates from the development in standard MOE sanitary sewer design table (Appendix 'C') format.	Appendix F
NA	Description of proposed sewer network including sewers, pumping stations, and forcemains.	Section 3.0

### Development Servicing Study Checklist

NA	Discussion of previously identified environmental constraints and impact on servicing (environmental constraints are related to limitation imposed on the development in order to preserve the physical condition of watercourse, vegetation, soil cover, as well as protecting against water quantity and quality).	
NA	Pumping stations: impacts of proposed development on existing pumping stations or requirements for new pumping station to services development.	
NA	Forcemain capacity in terms of operational redundancy, surge pressure and maximum flow velocity.	
NA	Identification and implementation of the emergency overflow from sanitary pumping station in relation to the hydraulic grade line to protect against basement flooding.	
NA	Special considerations such as contamination, corrosive environment etc.	
<b>4 Development Servicing Report: Stormwater Checklist</b>		<b>Comments</b>
Y	Description of drainage outlets and downstream constraints including legality of outlets (i.e. municipal drain, right-of-way, watercourse, or private property)	Section 4.1
NA	Analysis of available capacity in existing public infrastructure.	
Y	A drawing showing the subject lands, its surroundings, the receiving watercourse, existing drainage patterns, and proposed drainage patterns.	Figure A and Figure B in Appendix G
Y	Water quantity control objective (e.g. controlling post-development peak flows to pre-development level for storm event ranging from the 2 or 5 years event (dependent on the receiving sewer design) to 100 years return period); if other objectives are being applied, a rationale must be included with reference to hydrologic analyses of the potentially affected subwatershed, taking into account long-term cumulative effects.	Section 4.3
NA	Water Quality control objectives (basic, normal or enhanced level of protection based on the sensitivities of the receiving watercourse) and storage requirements.	
Y	Description of the stormwater management concept with facility locations and descriptions with references and supporting information.	Section 4.5
NA	Set-back from private sewage disposal systems.	
NA	Watercourse and hazard lands setbacks.	
Y	Record of pre-consultation with the Ontario Ministry of Environment and the Conservation Authority that has jurisdiction on the affected watershed.	Appendix A
NA	Confirm consistency with sub-watershed and Master Servicing Study, if applicable study exists.	
Y	Storage requirements (complete with calculations) and conveyance capacity for minor events (1:5 years return period) and major events (1:100 years return period).	Section 4.5 & Appendix G
NA	Identification of watercourses within the proposed development and how watercourses will be protected, or, if necessary, altered by the proposed development with applicable approvals.	
Y	Calculate pre and post development peak flow rates including a descriptions of existing site conditions and proposed impervious areas and drainage catchments in comparison to existing conditions.	Section 4.5 & Appendix G
NA	Any proposed diversion of drainage catchment areas from one outlet to another.	

<b>Development Servicing Study Checklist</b>		
Y	Proposed minor and major systems including locations and sizes of stormwater trunk sewers, and stormwater management facilities.	Drawings
NA	If quantity control is not proposed, demonstration that downstream system has adequate capacity for the post-development flows up to and including the 100-year return period storm event.	
NA	Identification of potential impacts to receiving watercourses.	
NA	Identification of municipal drains and related approvals requirements.	
Y	Descriptions of how the conveyance and storage capacity will be achieved for the development.	Section 4.5
Y	100 years flood levels and major flow routing to protect proposed development from flooding for establishing minimum building elevations (MBE) and overall grading.	Section 4.7
NA	Inclusion of hydraulic analysis including hydraulic grade line elevations.	
Y	Description of approach to erosion and sediment control during construction for the protection of receiving watercourse or drainage corridors.	Section 5.0
NA	Identification of floodplains - proponent to obtain relevant floodplain information from the appropriate Conservation Authority. The proponent may be required to delineate floodplain elevations to the satisfaction of the Conservation Authority if such information is not available or if information does not match current conditions.	
NA	Identification of fill constraints related to floodplain and geotechnical investigation.	
<b>5 Approval and Permit Requirements: Checklist</b>		<b>Comments</b>
NA	Conservation Authority as the designated approval agency for modification of floodplain, potential impact on fish habitat, proposed works in or adjacent to a watercourse, cut/fill permits and Approvals under Lakes and Rivers Improvements Act. The Conservation Authority is not the approval authority for the Lakes and Rivers Improvements Act. Where there are Conservation Authority regulations in place, approval under the Lakes and Rivers Improvements Act is not required, except in cases of dams as defined in the Act.	
NA	Application for Certificate of Approvals (CofA) under the Ontario Water Resources Act.	
NA	Change to Municipal Drains	
NA	Other permits (National Capital Commission, Parks Canada, Public Works and Government Services Canada, Ministry of Transportation etc.)	
<b>6 Conclusion Checklist</b>		<b>Comments</b>
Y	Clearly stated conclusion and recommendations.	Section 6.0
NA	Comments received from review agencies including the City of Ottawa and information on how the comments were addressed. Final sign-off from the responsible reviewing agency.	
Y	All draft and final reports shall be signed and stamped by a professional Engineer registered in Ontario.	Report

## APPENDIX C | DRAWINGS

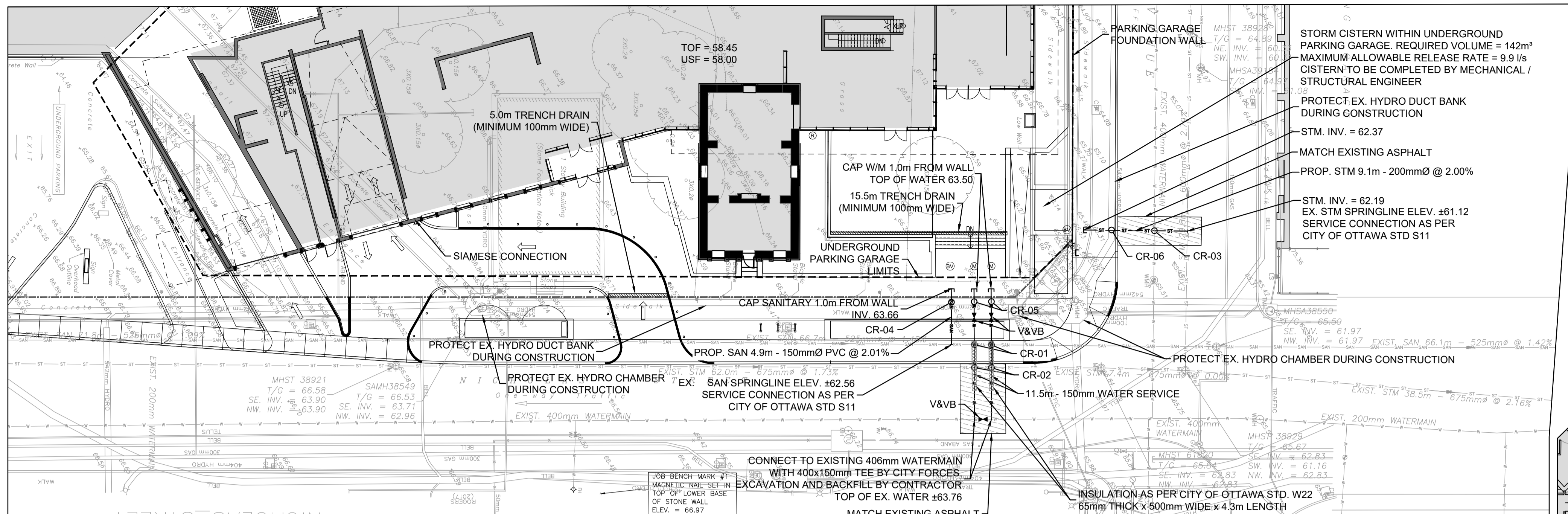

WATERMAIN SERVICE TABLE			
WATER SERVICE	OFFSET FROM EX. WATERMAIN	FITTING	TOP OF WATERMAIN ELEVATION
NICHOLAS ST. No.1	0.0m	TEE	63.64
	2.3m	45° VERT. BEND	63.64
	3.0m	45° VERT. BEND	64.24
	6.0m	45° VERT. BEND	64.24
	6.8m	45° VERT. BEND	63.45m
	9.0m	V&VB	63.45m
	11.5m	CAP	63.45m
NICHOLAS ST. No.2	0.0m	TEE	63.64
	2.3m	45° VERT. BEND	63.64
	3.0m	45° VERT. BEND	64.24
	6.0m	45° VERT. BEND	64.24
	6.8m	45° VERT. BEND	63.45m
	9.0m	V&VB	63.45m
	11.5m	CAP	63.45m

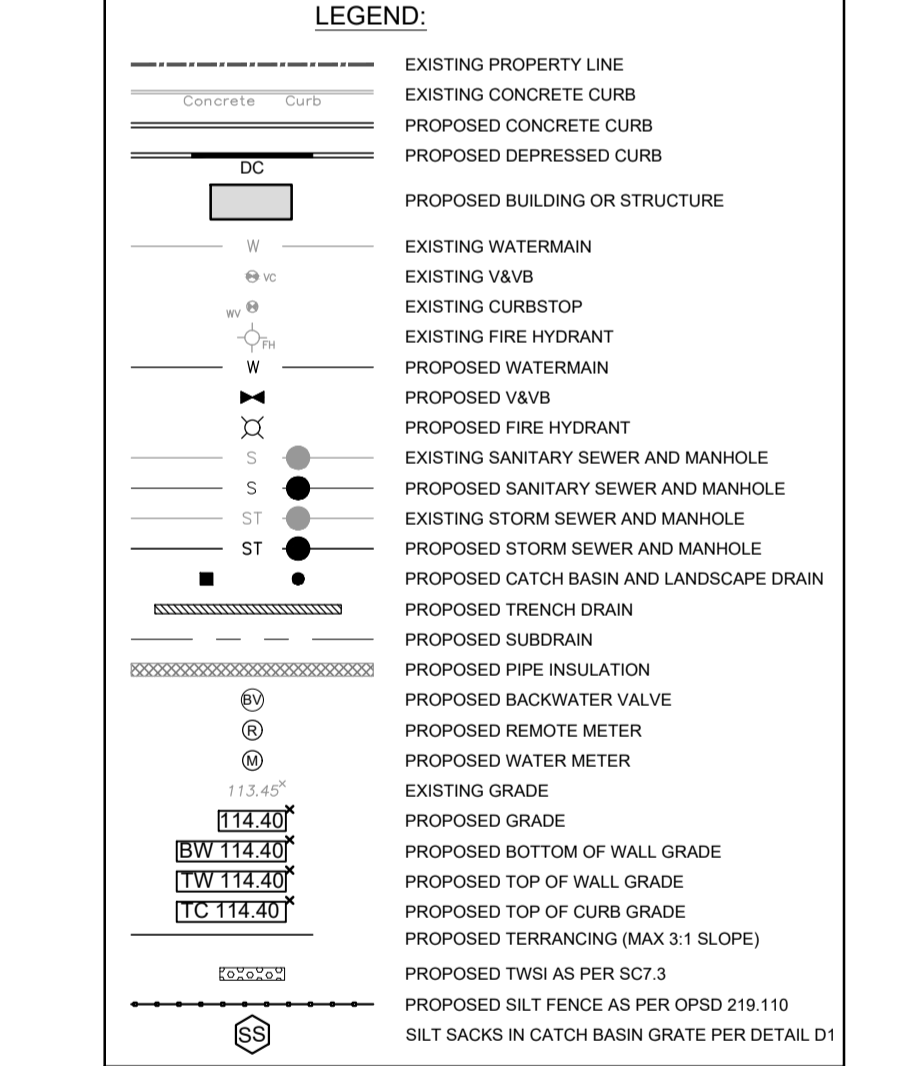

**NOTES: GENERAL**

- CONTRACTOR IS RESPONSIBLE FOR ALL LAYOUT FOR CONSTRUCTION PURPOSES.
- ALL ELEVATIONS ARE GEODETIC AND UTILIZE METRIC UNITS.
- JOB BENCH MARK - REFER TO SURVEY BY ADV. LTD. CONFIRM WITH CONTRACT ADMINISTRATOR PRIOR TO UTILIZATION OF BENCH MARK.
- ALL GROUND SURFACES SHALL BE EVENLY GRADED WITHOUT PONDING AREAS AND WITHOUT LOW POINTS EXCEPT WHERE APPROVED SWALE OR CATCH BASIN OUTLETS ARE PROVIDED.
- STRIP AND REMOVE ALL TOPSOIL FROM IMPROVED AREAS. COORDINATE AND SCHEDULE ALL WORK WITH OTHER TRADES AND CONTRACTORS.
- ALL EDGES OF DISTURBED PAVEMENT SHALL BE SAW CUT TO FORM A NEAT AND STRAIGHT LINE PRIOR TO PLACING NEW PAVEMENT. PAVEMENT REINSTATEMENT SHALL BE PER CITY OF OTTAWA STD. R10.
- CURBS TO BE CONCRETE BARRIER, CONSTRUCTED AS PER CITY OF OTTAWA DETAIL SC1.1. ELEVATIONS AT CURB INDICATE THE GRADE AT THE FINISHED ROAD SURFACE UNLESS NOTED OTHERWISE.
- RESTORE PAVEMENT STRUCTURE AND SURFACES ON EXISTING ROADS TO A CONDITION AT LEAST EQUAL TO ORIGINAL AND TO THE SATISFACTION OF THE MUNICIPAL AUTHORITIES.
- ALL MATERIAL SUPPLIED AND PLACED FOR PARKING LOT AND ACCESS ROAD CONSTRUCTION SHALL BE TO OPS STANDARDS AND SPECIFICATIONS UNLESS OTHERWISE NOTED. CONSTRUCTION TO OPS 206, 310 & 314. MATERIALS TO OPS 1001, 1003 & 1010.
- ABUTTING PROPERTY GRADE TO BE MATCHED.
- OBTAIN AND PAY FOR ALL NECESSARY PERMITS AND APPROVALS FROM THE MUNICIPAL AUTHORITIES PRIOR TO COMMENCING CONSTRUCTION.
- MINIMIZE DISTURBANCE TO EXISTING VEGETATION DURING THE EXECUTION OF ALL WORKS.
- FILTER FABRIC TO BE INSTALLED AND MAINTAINED BETWEEN THE FRAME AND COVER OF ALL CATCHBASINS AND CATCHBASIN MANHOLES DURING THE CONSTRUCTION PERIOD TO MINIMIZE SEDIMENTS ENTERING THE STORM SEWER SYSTEM. ALL GRASSED AREAS MUST BE COMPLETED PRIOR TO THE REMOVAL OF THE FILTER FABRIC IN THE CATCH BASINS.
- REMOVE FROM SITE ALL EXCESS EXCAVATED MATERIAL UNLESS OTHERWISE DIRECTED FROM THE ENGINEER. EXCAVATE AND REMOVE ALL ORGANIC MATERIAL AND DEBRIS LOCATED WITHIN THE

**NOTES: SEWER**

- SUPPLY AND INSTALL ALL SEWERS AND APPURTENANCES IN ACCORDANCE WITH MOST CURRENT CITY OF OTTAWA STANDARDS AND SPECIFICATIONS.
- WATERMAIN MATERIAL SHALL BE PVC, CL 150, DR-18 IN ACCORDANCE WITH CITY OF OTTAWA STANDARDS AND SPECIFICATIONS.
- ALL WATERMAIN TO BE INSTALLED AT MINIMUM COVER OF 2.4m BELOW FINISHED GRADE, WHERE REQUIRED, PROVIDE INSULATION IN ACCORDANCE WITH CITY OF OTTAWA STANDARDS W22 AND W23.
- WATERMAIN BEDDING AS PER CITY OF OTTAWA STANDARD W17.
- CONCRETE THRUST BLOCKS AND RESTRAINING AS PER DETAILS ON DRAWING C103.
- CATHODIC PROTECTION REQUIRED FOR ALL IRON FITTINGS.
- IF WATERMAIN MUST BE DEFLECTED TO MEET ALIGNMENT, ENSURE THAT THE AMOUNT OF DEFLECTION USED IS LESS THAN HALF THAT RECOMMENDED BY THE MANUFACTURER.
- EXCAVATION, INSTALLATION, AND BACKFILL BY CONTRACTOR. CONNECTIONS AND SHUT-OFFS AT THE MAIN BY CITY.

**NOTES: UNDERGROUND STORMWATER STORAGE**

- UNDERGROUND STORMWATER STORAGE REQUIRED: 142m<sup>3</sup>

**NOTES: WATERMAIN**

- SUPPLY AND INSTALL ALL WATERMAIN AND APPURTENANCES IN ACCORDANCE WITH MOST CURRENT CITY OF OTTAWA STANDARDS AND SPECIFICATIONS.
- WATERMAIN MATERIAL SHALL BE PVC, CL 150, DR-18 IN ACCORDANCE WITH CITY OF OTTAWA STANDARDS AND SPECIFICATIONS.
- ALL WATERMAIN TO BE INSTALLED AT MINIMUM COVER OF 2.4m BELOW FINISHED GRADE, WHERE REQUIRED, PROVIDE INSULATION IN ACCORDANCE WITH CITY OF OTTAWA STANDARDS W22 AND W23.
- WATERMAIN BEDDING AS PER CITY OF OTTAWA STANDARD W17.
- CONCRETE THRUST BLOCKS AND RESTRAINING AS PER DETAILS ON DRAWING C103.
- CATHODIC PROTECTION REQUIRED FOR ALL IRON FITTINGS.
- IF WATERMAIN MUST BE DEFLECTED TO MEET ALIGNMENT, ENSURE THAT THE AMOUNT OF DEFLECTION USED IS LESS THAN HALF THAT RECOMMENDED BY THE MANUFACTURER.
- EXCAVATION, INSTALLATION, AND BACKFILL BY CONTRACTOR. CONNECTIONS AND SHUT-OFFS AT THE MAIN BY CITY.

**NOTES: TRENCH DRAIN**

- TRENCH DRAIN TO BE DIRECTED INTERNALLY THROUGH THE UNDERGROUND PARKING GARAGE TO THE UNDERGROUND CISTERN. REFER TO MECHANICAL DRAWINGS FOR DETAILS.

**NOTES: EROSION AND SEDIMENT CONTROL MEASURES:**

- PRIOR TO START OF CONSTRUCTION:**
  - CONTRACTOR IS RESPONSIBLE FOR ALL INSTALLATION, MONITORING, REPAIR AND REMOVAL OF ALL EROSION AND SEDIMENT CONTROL FEATURES. THE CONTRACTOR SHALL IMPLEMENT BEST MANAGEMENT PRACTICES TO PROVIDE FOR PROTECTION OF THE AREA DRAINAGE SYSTEM AND THE RECEIVING WATERCOURSE. DURING CONSTRUCTION ACTIVITIES, THE CONTRACTOR ACKNOWLEDGES THAT FAILURE TO IMPLEMENT APPROPRIATE EROSION AND SEDIMENT CONTROL MEASURE MAY BE SUBJECT TO PENALTIES IMPOSED BY ANY APPLICABLE REGULATORY AGENCY.
  - SEDIMENT AND EROSION CONTROL PLAN OBJECTIVES:
    - PREVENT SOIL EROSION. THIS CAN RESULT FROM STREAMING RAIN WATER OR WIND EROSION DURING CONSTRUCTION.
    - PREVENT SEDIMENT DEPOSITS IN THE SEWER PIPES AND NEARBY COLLECTING STREAMS (AS APPLICABLE).
    - PREVENT AIR POLLUTION FROM PARTICULATE MATTER AND DUST.
- DURING CONSTRUCTION:**
  - SEDIMENT AND EROSION CONTROL MEASURES TO BE CONSTRUCTED AS PER OPS 805.
  - WHEN SEDIMENT AND EROSION CONTROL MEASURES MUST BE REMOVED TO COMPLETE A PORTION OF THE WORK, THE SAME MEASURES MUST BE REINSTATED UPON THE WORK'S COMPLETION.

**NOTES: GRADING & EROSION AND SEDIMENT CONTROL PLAN**

- WORK TO BE DONE IN THE VICINITY OF MAJOR WATERWAYS TO BE CARRIED OUT FROM JULY AND SEPTEMBER ONLY.
- MINIMIZE THE EXTENT OF DISTURBED AREAS AND THE DURATION OF EXPOSURE.
- PROTECT DISTURBED AREAS FROM RUNOFF.
- PROVIDE TEMPORARY COVER SUCH AS SEEDING OR MULCHING IF DISTURBED AREA WILL NOT BE REHABILITATED SHORTLY.
- INSPECT STRAW BALE FLOW CHECK DAMS, SILT FENCES, SILT SACKS, AND CATCH BASIN SUMPS REGULARLY AND AFTER EVERY MAJOR STORM EVENT AND REPAIR WHEN NECESSARY.
- PLAN TO BE REVIEWED AND REVISED AS REQUIRED DURING CONSTRUCTION.
- EROSION CONTROL FENCING TO BE ALSO INSTALLED AROUND THE BASE OF ALL STOCKPILES.
- DO NOT LOCATE TOPSOIL PILES AND EXCAVATION MATERIAL CLOSER THAN 2.5m FROM ANY PAVED SURFACE, OR ONE WHICH IS TO BE PAVED BEFORE THE PILE IS REMOVED. ALL TOPSOIL PILES ARE TO BE SEEDED IF THEY ARE TO REMAIN ON SITE LONG ENOUGH FOR SEEDS TO GROW (LONGER THAN 30 DAYS). WHEN STORING SOIL ON SITE IN PILES THE CONTRACTOR MUST COVER EACH PILE WITH TARPS, STRAW OR A GEOTEXTILE FABRIC TO AVOID FINE PARTICLE TRANSPORT BY WIND AND/OR STREAMING RAIN WATER.
- CONTROL WIND-BLOWN DUST OFF SITE TO ACCEPTABLE LEVELS BY SEEDING TOPSOIL PILES AND OTHER AREAS TEMPORARILY (PROVIDE WATERING AS REQUIRED). FOR DUST CONTROL, CONTRACTOR TO APPLY CALCIUM CHLORIDE (TYPE I - OPS 2501 AND CANCGSS-15-1) AND WATER WITH EQUIPMENT APPROVED BY THE OWNER'S REPRESENTATIVE AT RATE IN ACCORDANCE TO OPS 508 WHEN DIRECTED BY OWNER'S REPRESENTATIVE.
- ALL EROSION CONTROL STRUCTURE TO REMAIN IN PLACE UNTIL ALL DISTURBED GROUND SURFACES HAVE BEEN DESTABILIZED EITHER BY PAVING OR RESTORATION OF VEGETATIVE GROUND COVER. SEDIMENT CAPTURE SILT SACKS MUST BE MAINTAINED AND CANNOT BE REMOVED UNTIL ALL LANDSCAPING AREAS ARE COMPLETED.
- NO ALTERNATE METHODS OF EROSION PROTECTION SHALL BE PERMITTED UNLESS APPROVES BY THIS CONSULTING ENGINEER AND THE TOWN DEPARTMENT OF PUBLIC WORKS.
- CONTRACTOR RESPONSIBLE FOR MUNICIPAL ROADWAY AND SIDEWALK TO BE CLEANED OF ALL SEDIMENT FROM VEHICULAR TRACKING ETC. AT THE END OF EACH WORK DAY.
- DURING WET CONDITIONS, TIRES OF ALL VEHICLES/EQUIPMENT

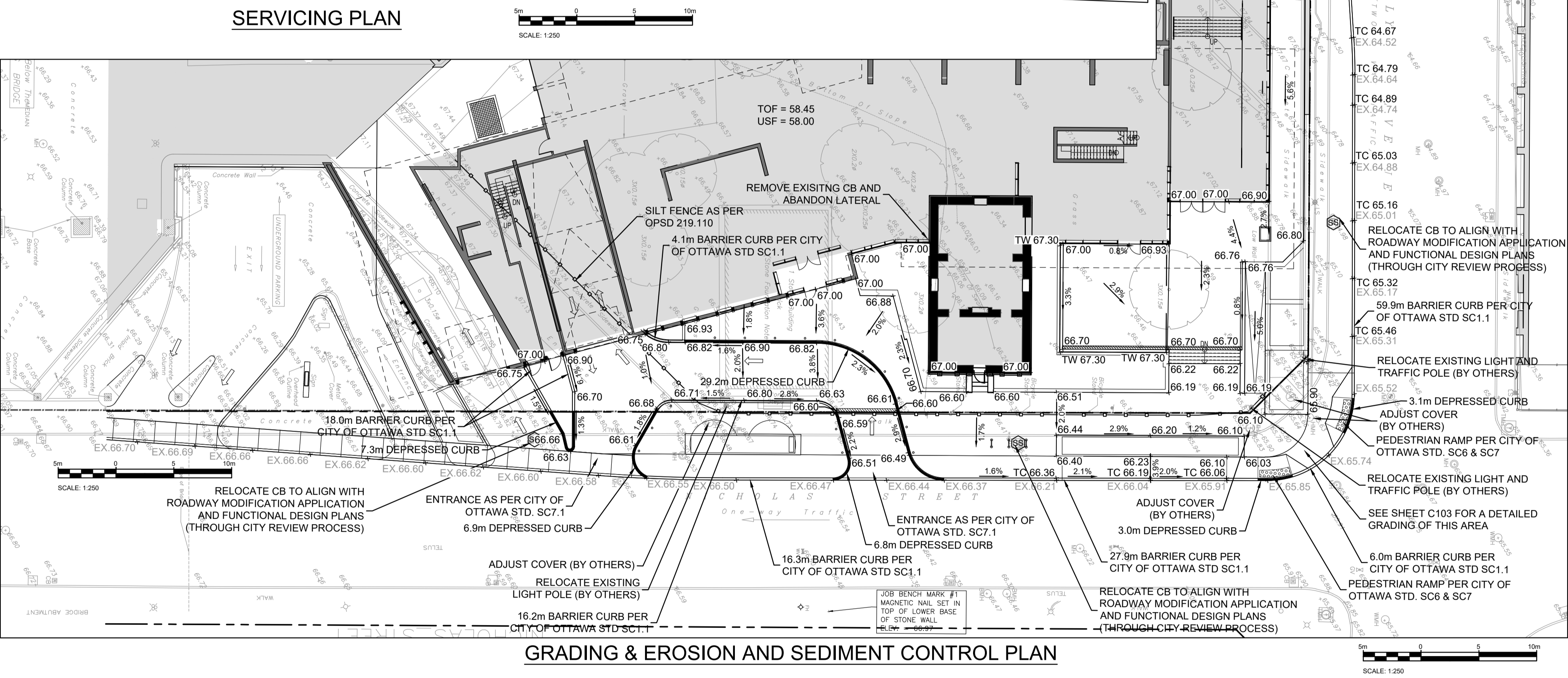
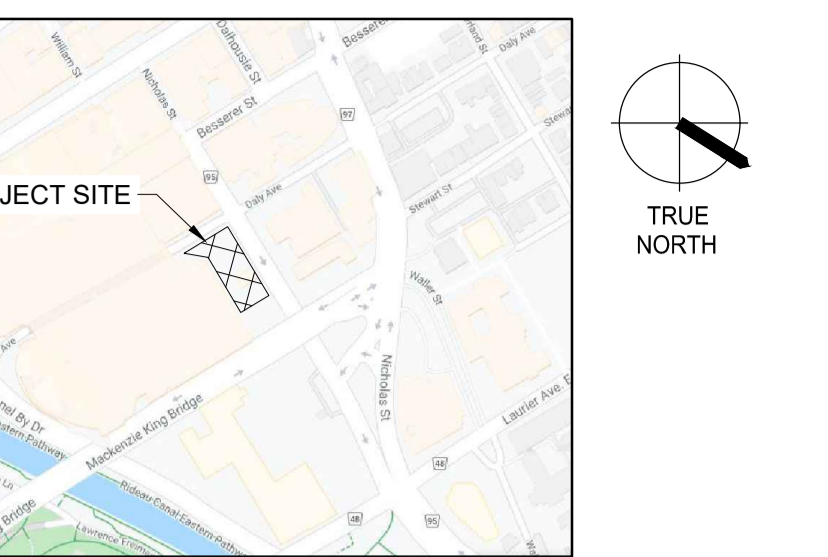

**zeidler**  
600-158 Sterling Road  
Toronto, ON M6R 2B7  
T +1 416 596 8300  
ZEIDLER.COM

**NEUF**  
ARCHITECTS  
406-47 Clarence Street  
Ottawa, ON K1N 9K1  
T +1 613 234 2274  
NEUFARCHITECTES.COM

**CF** Cadillac Fairview

**PARSONS**

**NOTE**

COPYRIGHT © ZEIDLER ARCHITECTURE INC.

CONTRACTOR MUST CHECK AND VERIFY ALL DIMENSIONS ON THE JOB. ANY DISCREPANCY OR CONTRADICTION INFORMATION WITHIN THIS SET OF DRAWINGS AND / OR OTHER CONSULTANTS' DRAWINGS MUST BE BROUGHT TO THE ATTENTION OF THE ARCHITECT BEFORE PROCEEDING.

**PROFESSIONAL ENGINEER**  
S.D. MITCHELSON  
100128064  
2022-12-09  
PROVINCE OF ONTARIO

NO.	ISSUE/REVISION	DATE
5	FINAL ISSUE TO SITE PLAN CONTROL	2022-12-09
4	FINAL ISSUE TO SITE PLAN CONTROL	2022-10-14
3	FINAL ISSUE TO SITE PLAN CONTROL	2022-08-24
2	RE-ISSUED TO SITE PLAN CONTROL	2022-04-29
1	ISSUED TO SITE PLAN CONTROL	2021-10-29

**NOT FOR CONSTRUCTION**

**CF RIDEAU CENTRE  
REGISTRY SITE**

**PROJECT ADDRESS**

70 NICOLAS ST.  
OTTAWA, ON

**SITE SERVICING, GRADING  
AND EROSION AND  
SEDIMENT CONTROL PLAN**

**PROJECT NO.** 477846 **DRAWN** JN **CHECKED** SM

**DRAWING NO.** D0718624 **REVISION NO.** 2

**SPA-C101**

D07-12-21-0197

**NOTE:**  
A. All dimensions are in millimetres unless otherwise shown.

ONTARIO PROVINCIAL STANDARD DRAWING Nov 2015 Rev 2  
LIGHT-DUTY SILT FENCE BARRIER OPSD 219.110

ALTERNATE STANDARD DRAWING

ALTERNATE DIMENSION	ALTERNATE DIMENSION
A	1800
B	1800
C	1500
D	1200

ONTARIO PROVINCIAL STANDARD DRAWING Nov 2019 Rev 4  
PRECAST CONCRETE CATCH BASIN 600x600mm OPSD 705.010

ONTARIO PROVINCIAL STANDARD DRAWING Nov 2019 Rev 2  
PRECAST CONCRETE MAINTENANCE HOLE 1200mm DIAMETER OPSD 701.010

Minimum No. 1	No. 1-4	No. 5	No. 6	No. 8	No. 9	No. 10
1200	700	850	750	700	850	950
1500	850	1200	950	850	1170	1170
1800	1200	1485	1290	1290	1485	1485
2400	1485	2020	1760	1485	2020	2020
3000	1935	2430	2300	1935	2430	2430
3600	2470	3045	2730	2470	3045	3045

ONTARIO PROVINCIAL STANDARD DRAWING Nov 2014 Rev 4  
MAINTENANCE HOLE BENCHING AND PIPE OPENING ALTERNATIVES OPSD 701.021

ONTARIO PROVINCIAL STANDARD DRAWING Nov 2014 Rev 3  
FLEXIBLE PIPE EMBEDMENT AND BACKFILL EARTH EXCAVATION OPSD 802.010

Clearance	Minimum	Maximum	Minimum	Maximum
1	100	100	100	100
2	100	100	100	100
3	100	100	100	100
4	100	100	100	100

ONTARIO PROVINCIAL STANDARD DRAWING Nov 2014 Rev 3  
FLEXIBLE PIPE EMBEDMENT AND BACKFILL ROCK EXCAVATION OPSD 802.013

ONTARIO PROVINCIAL STANDARD DRAWING Nov 2015 Rev 2  
INSTALLATION OF CATCH BASIN WITH MONOLITHIC SIDEWALK AND CURB, BARRIER, AND DEPRESSED CURB OPSD 400.07

ONTARIO PROVINCIAL STANDARD DRAWING Nov 2015 Rev 2  
HEAVY DUTY "FISH" TYPE ROUND CATCH BASIN COVER (MODIFIED OPSD-400.07) OPSD 400.07

ONTARIO PROVINCIAL STANDARD DRAWING Nov 2015 Rev 2  
SINGLE TRENCH (SEWER & SEWER SERVICES) OPSD 400.08

ONTARIO PROVINCIAL STANDARD DRAWING Nov 2015 Rev 2  
SEWER SERVICE CONNECTIONS FOR RIGID MAIN SEWER PIPE (MODIFIED OPSD-1006.01) OPSD 1006.01

ONTARIO PROVINCIAL STANDARD DRAWING Nov 2015 Rev 2  
SEWER SERVICE CONNECTIONS FOR RIGID MAIN SEWER PIPE USING BELL END INSERT METHOD OPSD 1006.02

ONTARIO PROVINCIAL STANDARD DRAWING Nov 2015 Rev 2  
FOUNDATION DRAIN BACKWATER VALVE INSTALLATION OPSD 1006.03

NOTE

COPYRIGHT © ZEIDLER ARCHITECTURE INC.

CONTRACTOR MUST CHECK AND VERIFY ALL DIMENSIONS ON THE JOB. ANY DISCREPANCY OR CONTRADICTION INFORMATION WITHIN THIS SET OF DRAWINGS AND / OR OTHER CONSULTANTS' DRAWINGS MUST BE BROUGHT TO THE ATTENTION OF THE ARCHITECT BEFORE PROCEEDING.

ONTARIO PROVINCIAL STANDARD DRAWING Nov 2015 Rev 2  
SANITARY BACKWATER VALVE INSTALLATION TYPE 2 OPSD 1006.04

ONTARIO PROVINCIAL STANDARD DRAWING Nov 2015 Rev 2  
STANDARD CIRCULAR SANITARY & COMBINED MAINTENANCE HOLE COVER OPSD 1006.05

ONTARIO PROVINCIAL STANDARD DRAWING Nov 2015 Rev 2  
STANDARD TRENCH REINSTATEMENT IN PAVED SURFACE OPSD 1006.06

ONTARIO PROVINCIAL STANDARD DRAWING Nov 2015 Rev 2  
SILT SACK DETAIL OPSD 1006.07

H	D	150	200	250	300	400	500	600	INSULATION THICKNESS
750	2250	2300	2350	2400	2500	2600	2700	100	
1000	1750	1800	1850	1900	2000	2100	2200	90	
1250	1250	1300	1350	1400	1500	1600	1700	80	
1500	750	800	850	900	1000	1100	1200	70	
1750	600	600	600	600	600	600	700	60	

ONTARIO PROVINCIAL STANDARD DRAWING Nov 2015 Rev 2  
THERMAL INSULATION FOR SEWER IN SHALLOW TRENCHES OPSD 1006.08

ONTARIO PROVINCIAL STANDARD DRAWING Nov 2015 Rev 2  
SANITARY BACKWATER VALVE INSTALLATION TYPE 1 OPSD 1006.09

NO.	ISSUE/REVISION	DATE
5	FINAL ISSUE TO SITE PLAN CONTROL	2022-12-09
4	FINAL ISSUE TO SITE PLAN CONTROL	2022-10-14
3	FINAL ISSUE TO SITE PLAN CONTROL	2022-08-24
2	RE-ISSUED TO SITE PLAN CONTROL	2022-04-29
1	ISSUED TO SITE PLAN CONTROL	2021-10-29

NOT FOR CONSTRUCTION

PROJECT  
**CF RIDEAU CENTRE  
REGISTRY SITE**

PROJECT ADDRESS  
70 NICOLAS ST.  
OTTAWA, ON

TITLE  
**DETAILS**

PROJECT NO. 477846 DRAWN JN CHECKED SM

DRAWING NO. 01718624 REVISION NO.

**SPA-C102**

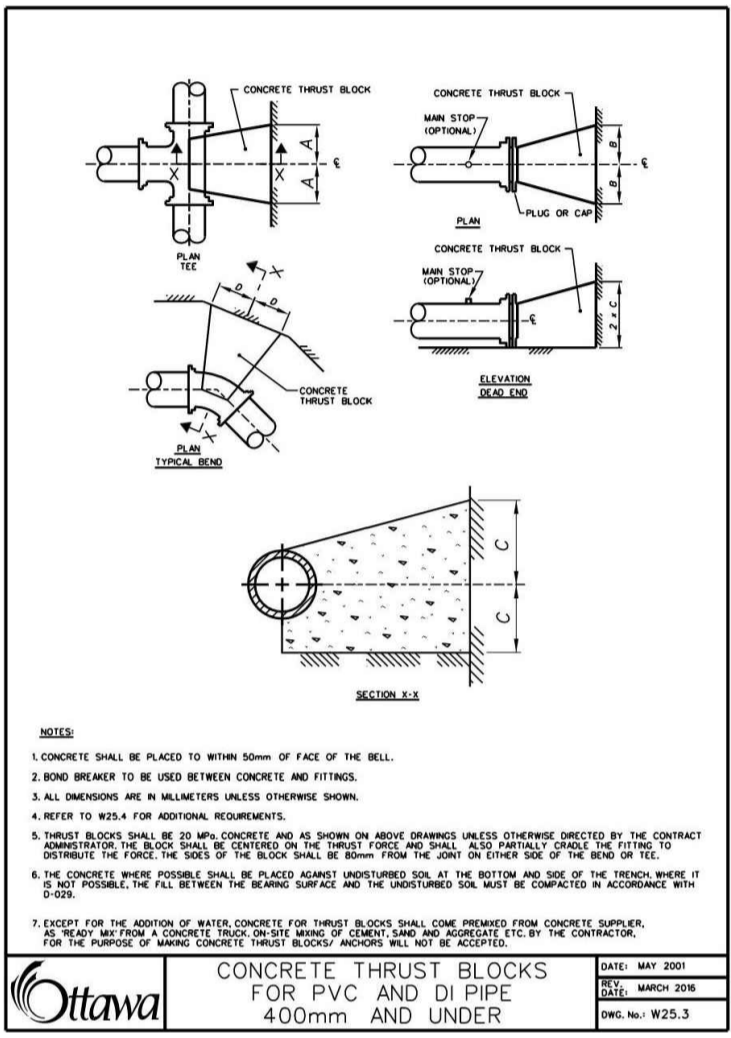
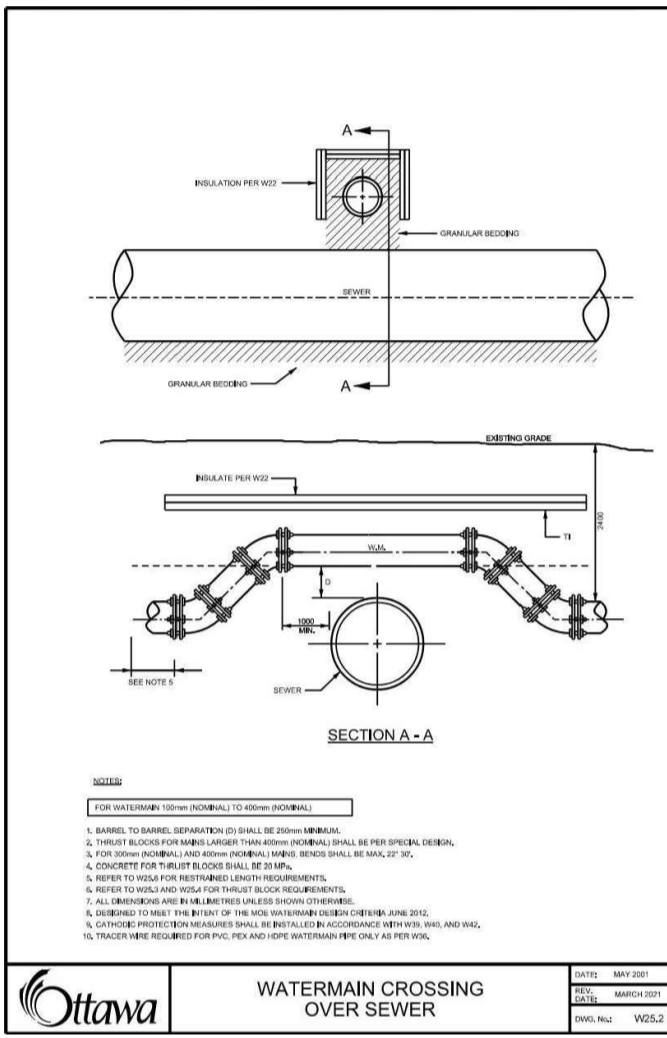
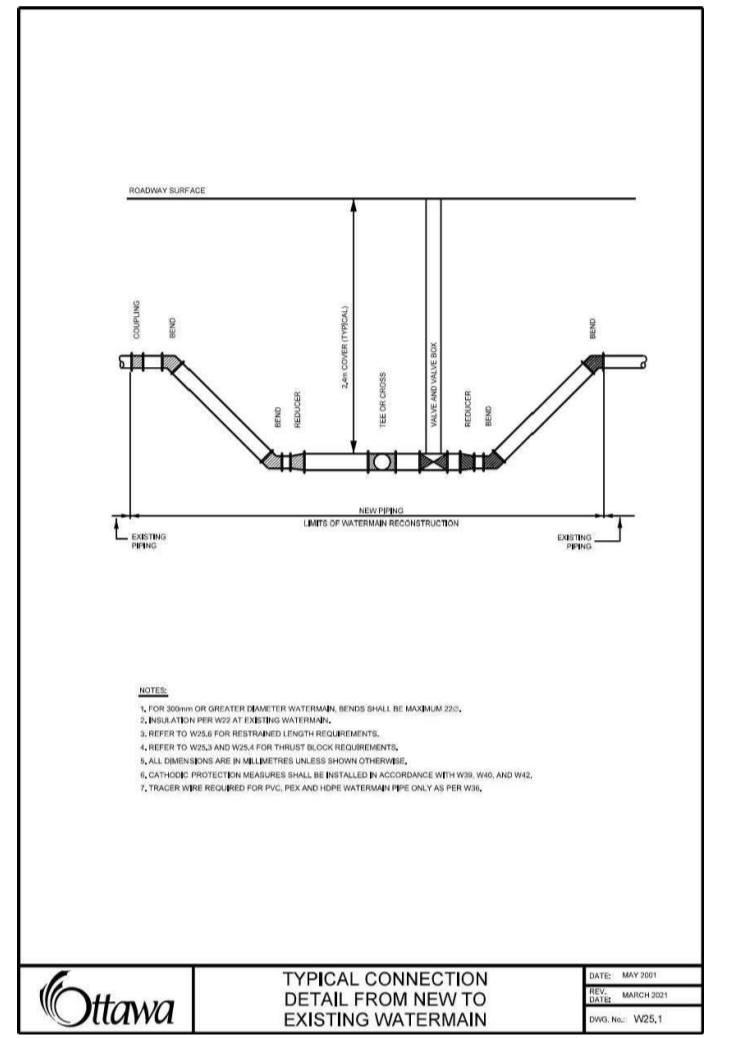
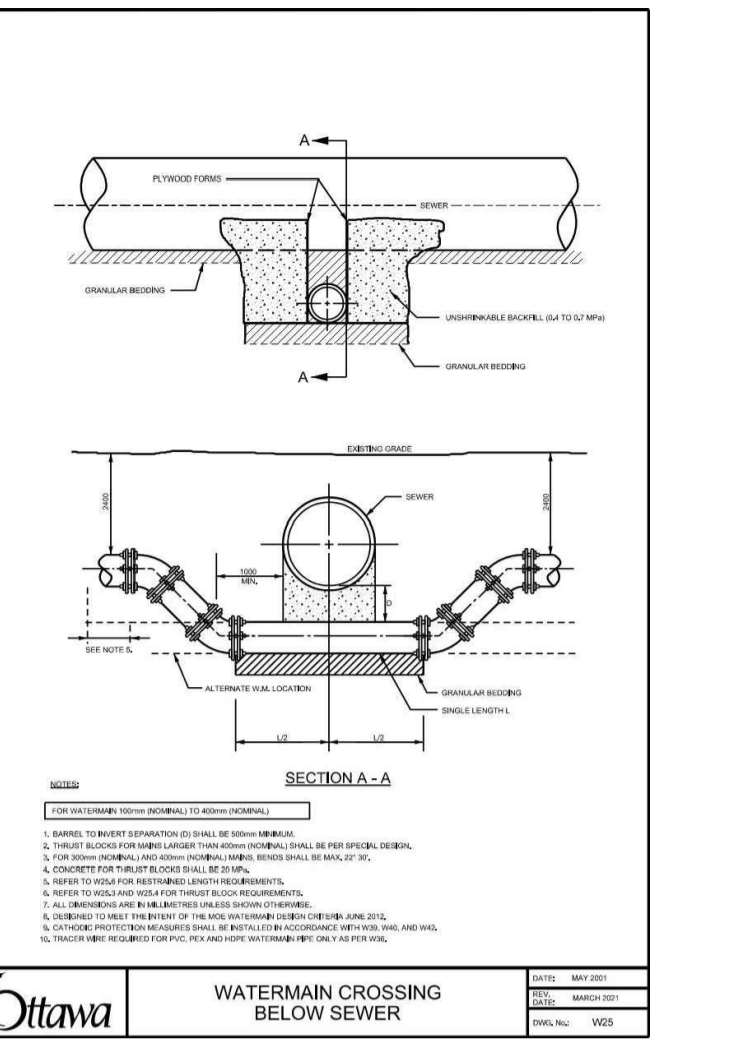
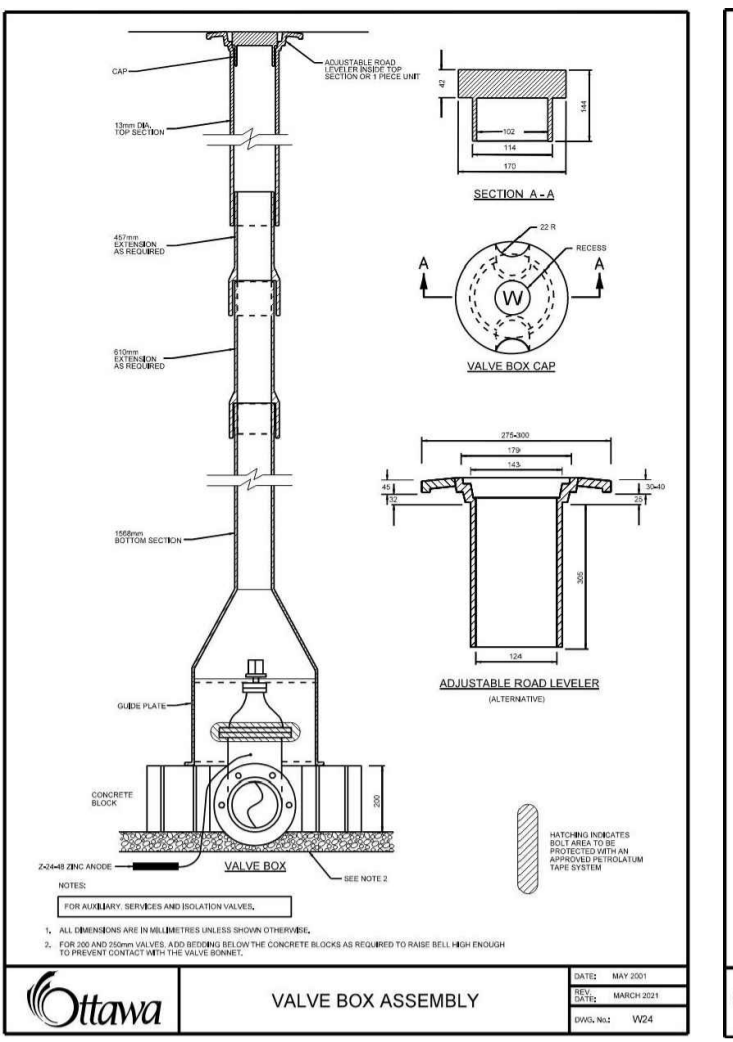
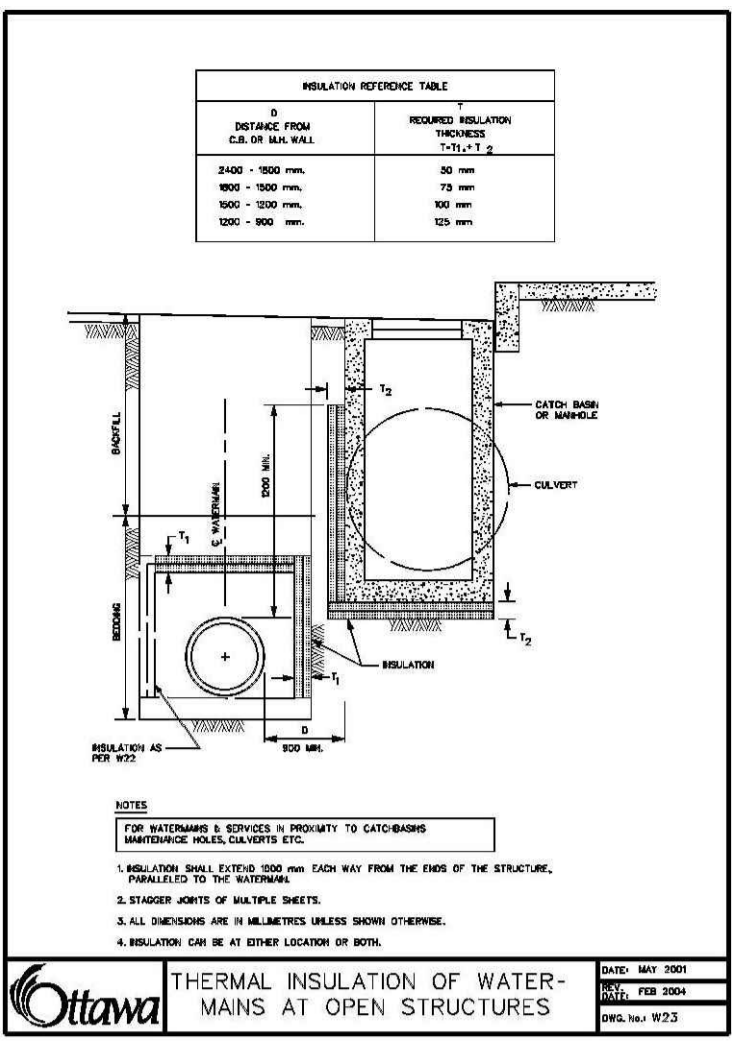
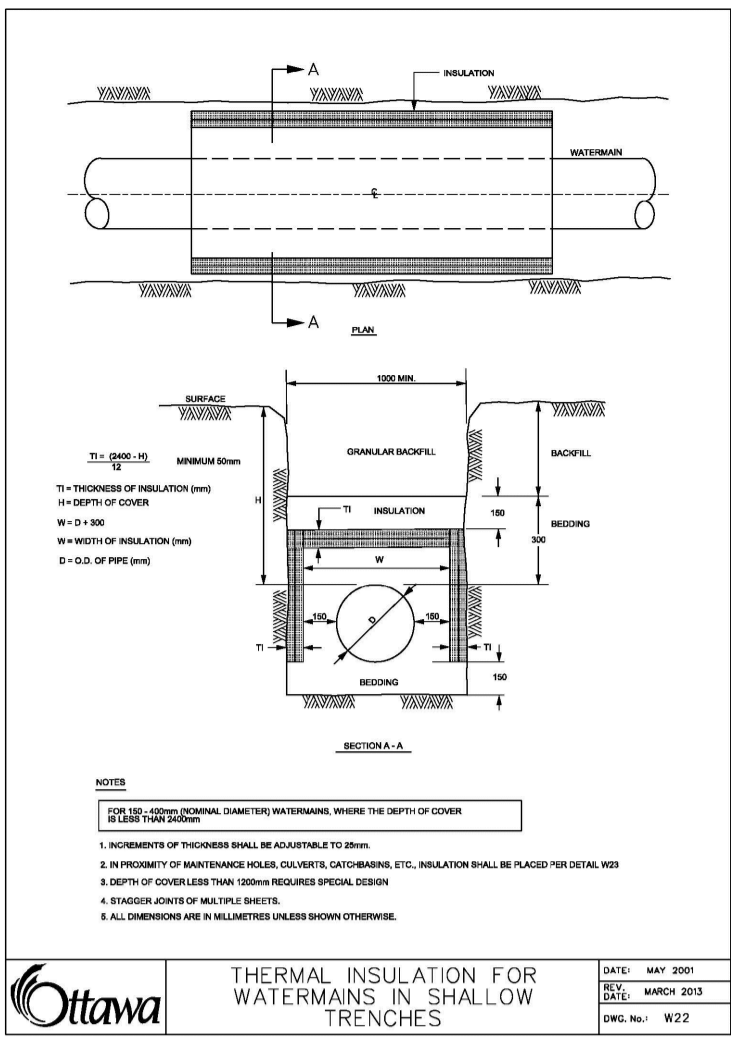
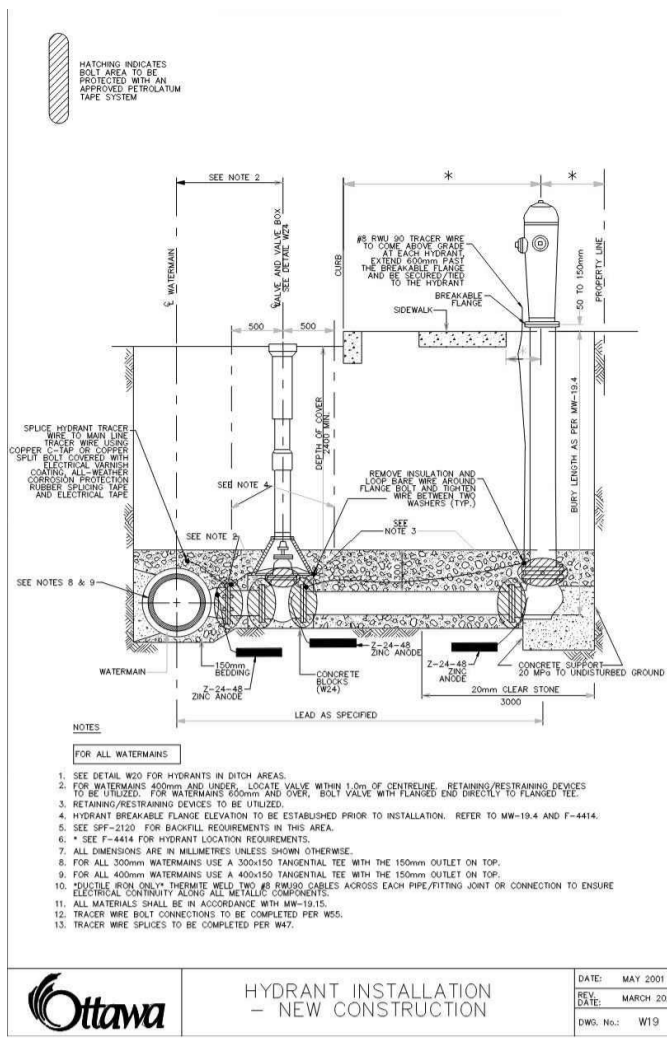
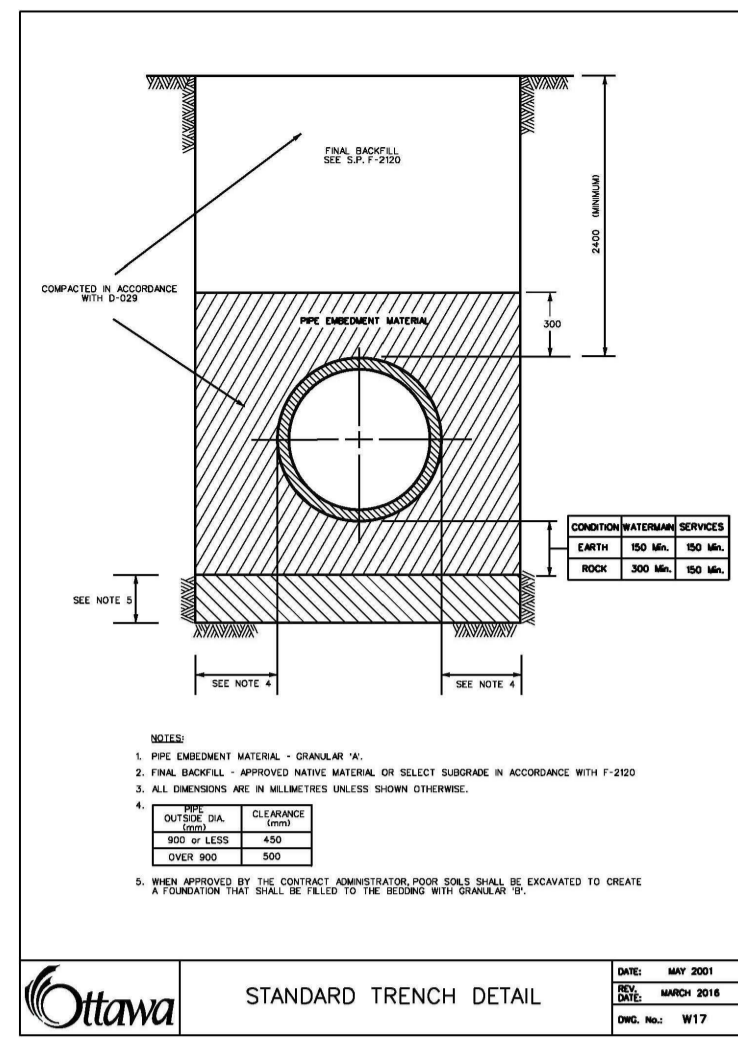

1. SOIL DESCRIPTION VERY FINE SANDS, SANDY CLAYS, CLAYS, SILTS WITH TYPICAL BEARING STRENGTH OF 100 TO 150 KPa. DIMENSION NOTED ON ROLL.

PIPE DIAMETER (mm)	A	B	C	D
102	200	200	200	200
152	300	300	300	300
203	400	400	400	400
254	500	500	500	500
305	600	600	600	600
406	750	750	750	750

2. SOIL DESCRIPTION SILTY SAND, GRAVELS OR CLAYEY SAND GRAVEL. SOILS WITH TYPICAL BEARING STRENGTH OF 200 TO 250 KPa. DIMENSION NOTED ON ROLL.

PIPE DIAMETER (mm)	A	B	C	D
102	200	200	200	200
152	300	300	300	300
203	300	300	200	270
254	400	400	300	300
305	500	500	300	400
406	750	750	400	600

3. SOIL DESCRIPTION VERY FINE SANDS, GRAVELS AND GRAVEL-SAND MIXTURES. SOILS WITH TYPICAL BEARING STRENGTH OF 300 KPa AND OVER. DIMENSION NOTED ON ROLL.

PIPE DIAMETER (mm)	A	B	C	D
102	200	200	200	200
152	300	300	300	300
203	300	300	200	270
254	400	400	300	300
305	500	500	300	400
406	750	750	400	600

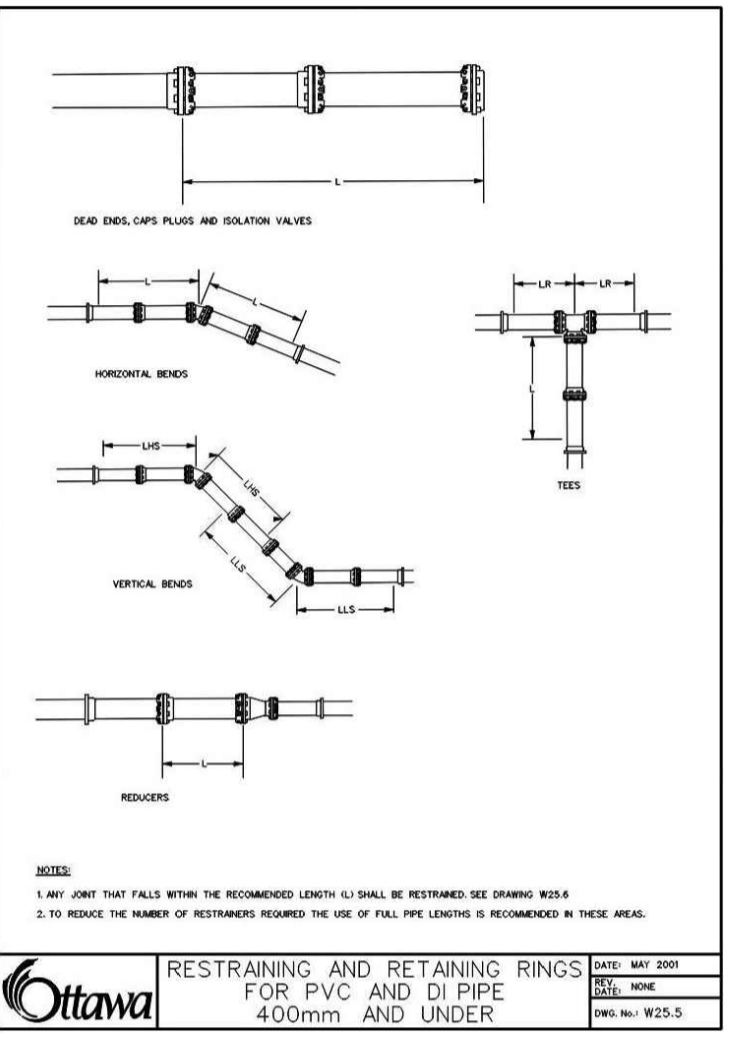
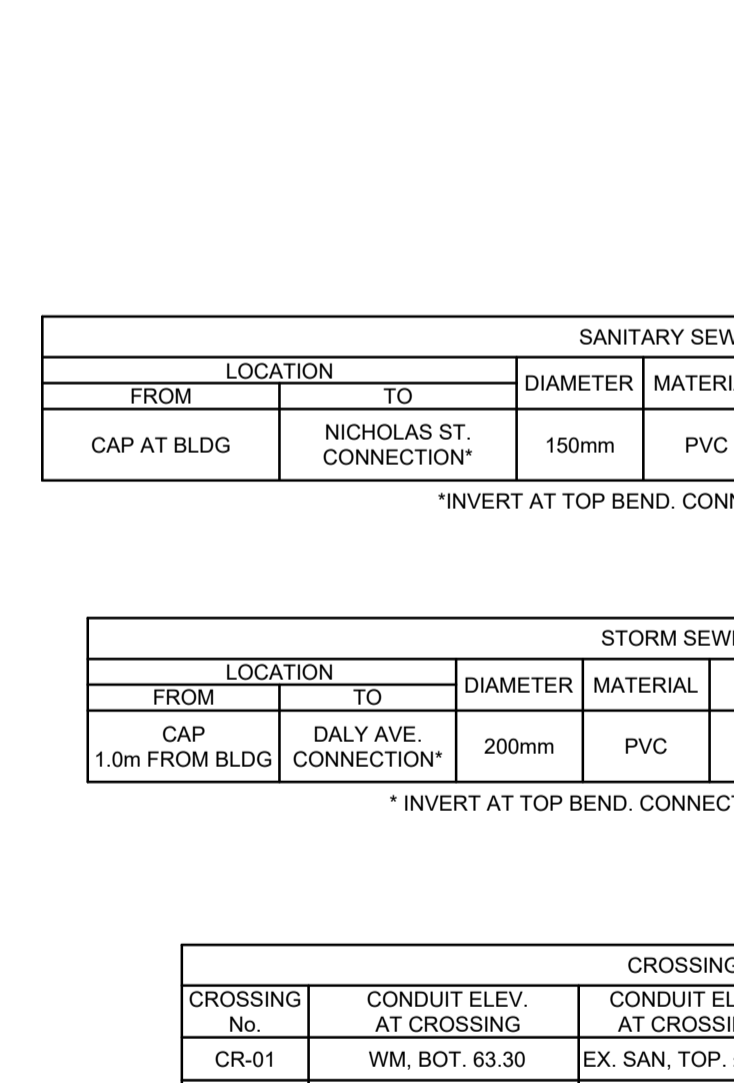
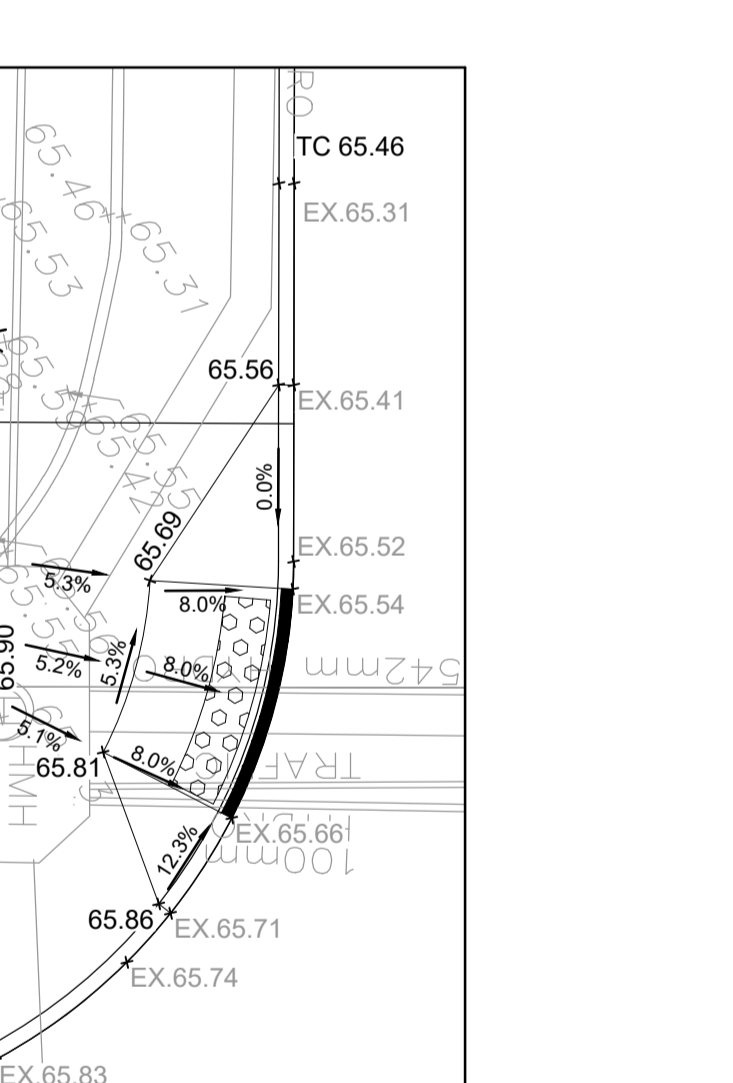
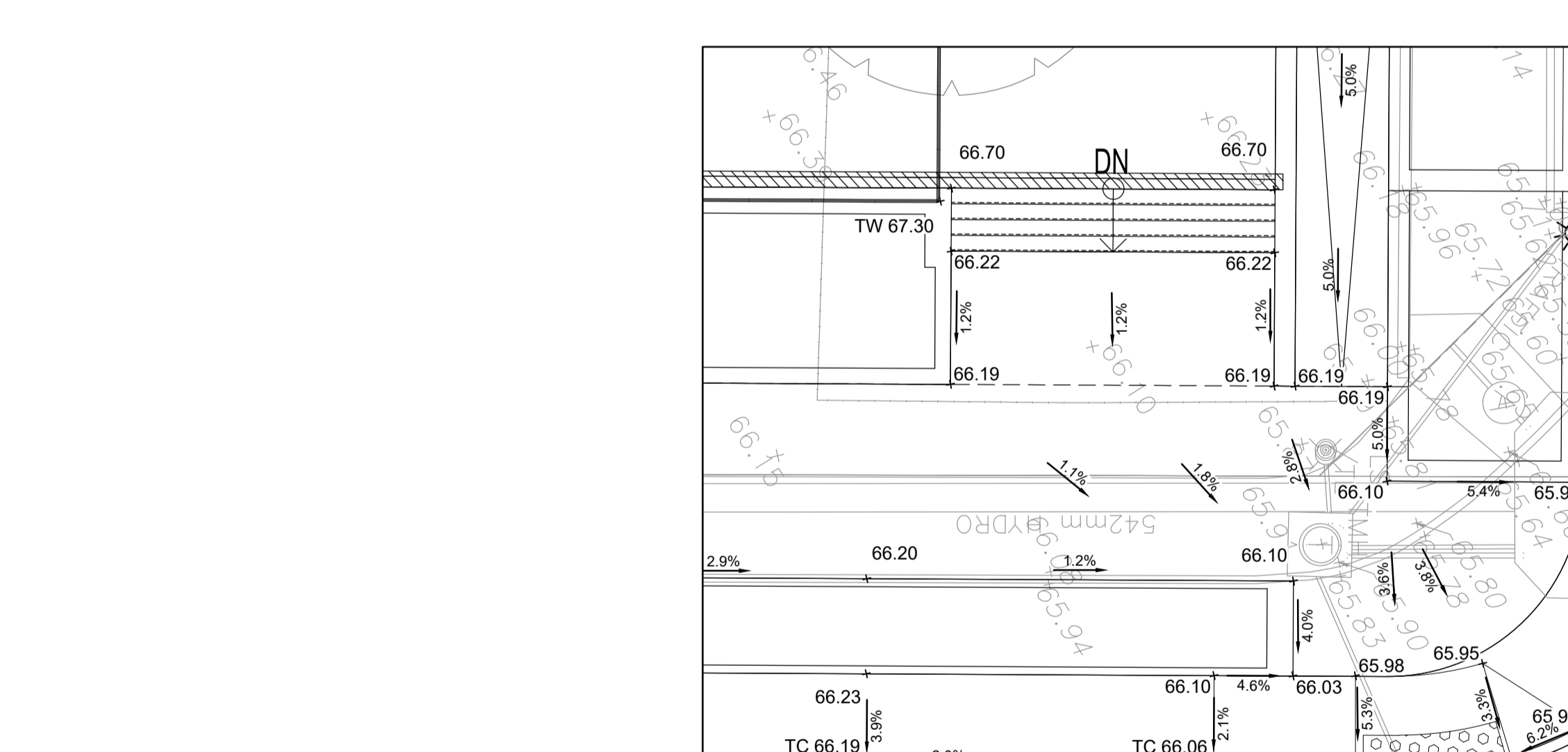
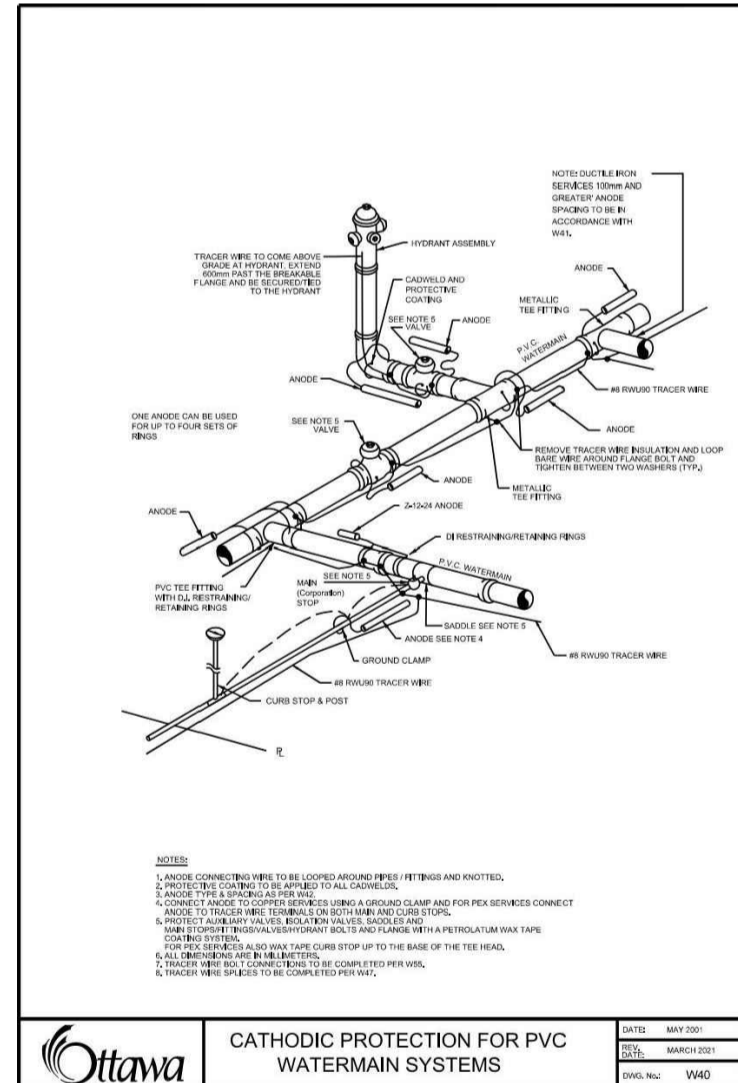
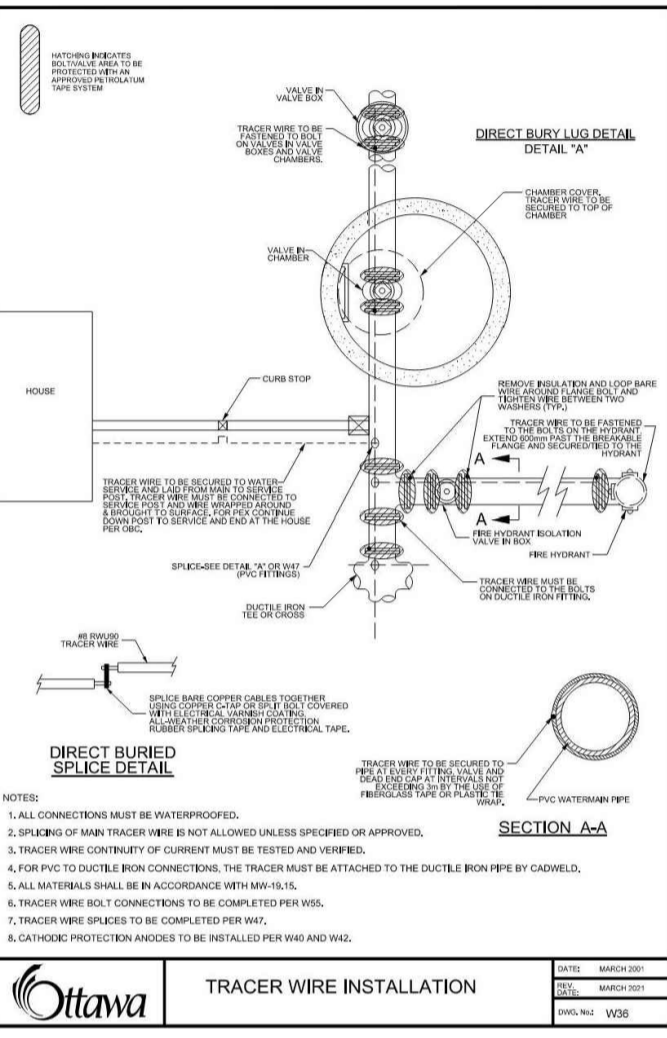

TABLE OF RESTRAINED LENGTHS FOR PVC AND DI PIPE WITH TYPICAL BEARING STRENGTH OF 100 TO 150 KPa

SMALLER DIAMETER (UNRESTRAINED)	LARGER DIAMETER SIDE TO BE RESTRAINED					
	100mm	150mm	200mm	250mm	300mm	400mm
100mm	N/A	3	6	8	10	14
150mm	N/A	N/A	6	8	9	13
200mm	N/A	N/A	N/A	3	6	11
250mm	N/A	N/A	N/A	N/A	3	8
300mm	N/A	N/A	N/A	N/A	N/A	7
400mm	N/A	N/A	N/A	N/A	N/A	N/A

TABLES OF RESTRAINED LENGTHS FOR PVC AND DI PIPE WITH TYPICAL BEARING STRENGTH OF 200 TO 250 KPa

SMALLER DIAMETER (UNRESTRAINED)	LARGER DIAMETER SIDE TO BE RESTRAINED					
	100mm	150mm	200mm	250mm	300mm	400mm
100mm	N/A	3	6	8	10	14
150mm	N/A	N/A	6	8	9	13
200mm	N/A	N/A	N/A	3	6	11
250mm	N/A	N/A	N/A	N/A	3	8
300mm	N/A	N/A	N/A	N/A	N/A	7
400mm	N/A	N/A	N/A	N/A	N/A	N/A



CROSSING TABLE

CROSSING No.	CONDUIT ELEV. AT CROSSING	CONDUIT ELEV. AT CROSSING	CLEARANCE	CITY OTTAWA STANDARD DETAIL
CR-01	WM, BOT. 63.30	EX. SAN, TOP. #62.88	0.42m	-
CR-02	WM, BOT. 64.09	EX. STM, TOP. #63.79	0.30m	W25.2
CR-03	EX. WM, BOT. #62.75*	STM, TOP. 62.45	0.30m	-
CR-04	EX. HYDRO, BOT. #64.96*	SAN, TOP. 63.81	1.15m	-
CR-05	EX. HYDRO, BOT. #64.96*	WM, TOP. 63.50	1.46m	-
CR-06	EX. HYDRO, BOT. #64.27*	STM, TOP. 62.52	1.75m	-

**zeidler**  
600-158 Sterling Road  
Toronto, ON M6R 2B7  
T +1 416 596 8300  
ZEIDLER.COM

**NEUF** ARCHITECTS  
406-47 Clarence Street  
Ottawa, ON K1N 9K1  
T +1 613 234 2274  
NEUFARCHITECTES.COM

**CF** Cadillac Fairview

**PARSONS**

NOTE  
COPYRIGHT © ZEIDLER ARCHITECTURE INC.  
CONTRACTOR MUST CHECK AND VERIFY ALL DIMENSIONS ON THE JOB. ANY DISCREPANCY OR CONTRADICTION INFORMATION WITHIN THIS SET OF DRAWINGS AND / OR OTHER CONSULTANTS' DRAWINGS MUST BE BROUGHT TO THE ATTENTION OF THE ARCHITECT BEFORE PROCEEDING.

PROFESSIONAL ENGINEER  
S.D. MITCHELSON  
100128064  
2022-12-09  
PROVINCE OF ONTARIO

NO.	ISSUE/REVISION	DATE
5	FINAL ISSUE TO SITE PLAN CONTROL	2022-12-09
4	FINAL ISSUE TO SITE PLAN CONTROL	2022-10-14
3	FINAL ISSUE TO SITE PLAN CONTROL	2022-08-24
2	RE-ISSUED TO SITE PLAN CONTROL	2022-04-29
1	ISSUED TO SITE PLAN CONTROL	2021-10-29

NOT FOR CONSTRUCTION

PROJECT  
**CF RIDEAU CENTRE  
REGISTRY SITE**  
PROJECT ADDRESS  
70 NICOLAS ST.  
OTTAWA, ON

TITLE  
**WATERMAIN DETAILS  
AND SEWER TABLES**

PROJECT NO. 477846 DRAWN: JN CHECKED: SM  
DRAWING NO. D0718624 REVISION NO. 2  
**SPA-C103**

## APPENDIX D | BOUNDARY CONDITIONS

## Mitchelson, Sarah [NN-CA]

---

**From:** Fawzi, Mohammed <mohammed.fawzi@ottawa.ca>  
**Sent:** Monday, August 29, 2022 9:24 AM  
**To:** Mitchelson, Sarah [NN-CA]  
**Cc:** Paradis, Kelly [NN-CA]  
**Subject:** [EXTERNAL] RE: CF Rideau Registry Site Plan Development - Boundary Conditions  
**Attachments:** CF Rideau Centre Condo REVISED August 2022.pdf

**Follow Up Flag:** Follow up  
**Flag Status:** Flagged

Hi Sarah,

As per technical bulletin 2021-03, the OBC method can be used if the site is not designing a watermain and the OBC method results in a fire demand less than 150 L/s.

The following are boundary conditions, HGL, for hydraulic analysis at CF Rideau Condo Development (zone 1W) assumed to be connected to the public 406 mm watermain on Nicholas at Daly Avenue and the public 406 mm watermain on Nicholas Street (see attached PDF for location).

### Scenario 1: Nicholas Connection

Minimum HGL: 106.4 m

Maximum HGL: 115.4 m

Max Day + FF (67 L/s): 109.4 m

### Scenario 2: Nicholas @ Daly Connection

Minimum HGL: 106.4 m

Maximum HGL: 115.4 m

Max Day + FF (67 L/s): 109.4 m

### Scenario 3: Both Connections

Minimum HGL: 106.4 m

Maximum HGL: 115.4 m

Max Day + FF (67 L/s): 109.4 m (Nicholas @ Daly) and 109.4 m (Nicholas)

These are for current conditions and are based on computer model simulation.

*Disclaimer: The boundary condition information is based on current operation of the city water distribution system. The computer model simulation is based on the best information available at the time. The operation of the water distribution system can change on a regular basis, resulting in a variation in boundary conditions. The physical properties of watermains deteriorate over time, as such must be assumed in the absence of actual field test data. The variation in physical watermain properties can therefore alter the results of the computer model simulation.*

Best Regards,

**Mohammed Fawzi, P.Eng.**

Project Manager

Planning, Infrastructure and Economic Development Department - Services de la planification, de l'infrastructure et du développement économique

Development Review - Central Branch

City of Ottawa | Ville d'Ottawa

110 Laurier Avenue West Ottawa, ON | 110, avenue. Laurier Ouest. Ottawa (Ontario) K1P 1J1

613.580.2424 ext./poste 20120, [Mohammed.Fawzi@ottawa.ca](mailto:Mohammed.Fawzi@ottawa.ca)

**\*\*Please note that due to the current situation, I am working remotely. Email is currently the best way to contact me\*\***

---

**From:** Fawzi, Mohammed

**Sent:** August 17, 2022 11:17 AM

**To:** Sarah.Mitchelson@parsons.com

**Cc:** Paradis, Kelly <Kelly.Paradis@parsons.com>

**Subject:** RE: CF Rideau Registry Site Plan Development - Boundary Conditions

Hi Sarah,

This is to confirm your request has been received.

Best Regards,

**Mohammed Fawzi, P.Eng.**

Project Manager

Planning, Infrastructure and Economic Development Department - Services de la planification, de l'infrastructure et du développement économique

Development Review - Central Branch

City of Ottawa | Ville d'Ottawa

110 Laurier Avenue West Ottawa, ON | 110, avenue. Laurier Ouest. Ottawa (Ontario) K1P 1J1

613.580.2424 ext./poste 20120, [Mohammed.Fawzi@ottawa.ca](mailto:Mohammed.Fawzi@ottawa.ca)

**\*\*Please note that due to the current situation, I am working remotely. Email is currently the best way to contact me\*\***

---

**From:** [Sarah.Mitchelson@parsons.com](mailto:Sarah.Mitchelson@parsons.com) <[Sarah.Mitchelson@parsons.com](mailto:Sarah.Mitchelson@parsons.com)>

**Sent:** August 15, 2022 9:25 PM

**To:** Fawzi, Mohammed <[mohammed.fawzi@ottawa.ca](mailto:mohammed.fawzi@ottawa.ca)>

**Cc:** Paradis, Kelly <[Kelly.Paradis@parsons.com](mailto:Kelly.Paradis@parsons.com)>

**Subject:** FW: CF Rideau Registry Site Plan Development - Boundary Conditions

**CAUTION: This email originated from an External Sender. Please do not click links or open attachments unless you recognize the source.**

**ATTENTION : Ce courriel provient d'un expéditeur externe. Ne cliquez sur aucun lien et n'ouvrez pas de pièce jointe, excepté si vous connaissez l'expéditeur.**

Sensitive

Hi Fawzi,

Can you please provide revised boundary conditions to align with the revised demands that were submitted in the latest version (April 2022) of the report?

The revised demands are as follows:

- Average Day Demand = 2.4L/s
- Maximum Day Demand = 7.2L/s
- Peak Hour Demand = 10.7L/s
- Fire Demand = 67L/s

Regards,  
Sarah

**SARAH MITCHELSON, P.ENG**

Municipal Engineer

1223 Michael Street North, Suite 100, Ottawa, ON K1J 7T2

[sarah.mitchelson@parsons.com](mailto:sarah.mitchelson@parsons.com)

Direct: +1 613.691.1609 / Mobile: +1 613.698.6705

[Parsons \[can01.safelinks.protection.outlook.com\]](mailto:can01.safelinks.protection.outlook.com) / [LinkedIn \[can01.safelinks.protection.outlook.com\]](#) / [Twitter \[can01.safelinks.protection.outlook.com\]](#) / [Facebook \[can01.safelinks.protection.outlook.com\]](#) / [Instagram \[can01.safelinks.protection.outlook.com\]](#)



---

**From:** Wu, John <[John.Wu@ottawa.ca](mailto:John.Wu@ottawa.ca)>

**Sent:** Wednesday, October 20, 2021 2:13 PM

**To:** Mitchelson, Sarah <[Sarah.Mitchelson@parsons.com](mailto:Sarah.Mitchelson@parsons.com)>

**Subject:** [EXTERNAL] RE: CF Rideau Registry Site Plan Development - Boundary Conditions

Hi, Sarah:

The 406mm loop from MacKenzie to Nicholas was considered as it was assumed this site's private watermain. If this is not their private watermain, this boundary condition should be resubmitted.

**\*\*\*\*The following information may be passed on to the consultant, but do NOT forward this e-mail directly.\*\*\*\***

The following are boundary conditions, HGL, for hydraulic analysis at CF Rideau Condo Development (zone 1W) assumed to be connected to the public 406 mm watermain on Nicholas at Daly Avenue and the public 406 mm watermain on Nicholas Street (see attached PDF for location).

Scenario 1: Nicholas Connection

Minimum HGL: 106.7 m

Maximum HGL: 115.4 m

Max Day + FF (400 L/s): 105.7 m

Scenario 2: Nicholas @ Daly Connection

Minimum HGL: 106.7 m

Maximum HGL: 115.4 m

Max Day + FF (400 L/s): 106.5 m

Scenario 3: Both Connections

Minimum HGL: 106.7 m

Maximum HGL: 115.4 m

Max Day + FF (400 L/s): 106.5 m (Nicholas @ Daly) and 105.7 m (Nicholas)

These are for current conditions and are based on computer model simulation.

*Disclaimer: The boundary condition information is based on current operation of the city water distribution system. The computer model simulation is based on the best information available at the time. The operation of the water distribution system can change on a regular basis, resulting in a variation in boundary conditions. The physical properties of watermains deteriorate over time, as such must be assumed in the absence of actual field test data. The variation in physical watermain properties can therefore alter the results of the computer model simulation.*

We also think 400 L/S fire flow is too high, please consider fire walls and/or sprinklers to reduce fire demands.

John

---

**From:** Mitchelson, Sarah <[Sarah.Mitchelson@parsons.com](mailto:Sarah.Mitchelson@parsons.com)>  
**Sent:** October 15, 2021 12:55 PM  
**To:** Wu, John <[John.Wu@ottawa.ca](mailto:John.Wu@ottawa.ca)>  
**Subject:** RE: CF Rideau Registry Site Plan Development - Boundary Conditions

**CAUTION: This email originated from an External Sender. Please do not click links or open attachments unless you recognize the source.**

**ATTENTION : Ce courriel provient d'un expéditeur externe. Ne cliquez sur aucun lien et n'ouvrez pas de pièce jointe, excepté si vous connaissez l'expéditeur.**

Sensitive

Hi John,

Just wanted to follow up with the boundary conditions – is this something we can expect today or early next week?

Regards,  
Sarah

**SARAH MITCHELSON, P.ENG**

Municipal Engineer

1223 Michael Street North, Suite 100, Ottawa, ON K1J 7T2

[sarah.mitchelson@parsons.com](mailto:sarah.mitchelson@parsons.com)

Direct: +1 613.691.1609 / Mobile: +1 613.698.6705

[Parsons \[can01.safelinks.protection.outlook.com\] \[can01.safelinks.protection.outlook.com\]](#) / [LinkedIn](#)

[\[can01.safelinks.protection.outlook.com\] \[can01.safelinks.protection.outlook.com\]](#) / [Twitter](#)

[\[can01.safelinks.protection.outlook.com\] \[can01.safelinks.protection.outlook.com\]](#) / [Facebook](#)

[\[can01.safelinks.protection.outlook.com\] \[can01.safelinks.protection.outlook.com\]](#) / [Instagram](#)

[\[can01.safelinks.protection.outlook.com\] \[can01.safelinks.protection.outlook.com\]](#)



---

**From:** Mitchelson, Sarah

**Sent:** Tuesday, October 12, 2021 8:30 PM

**To:** Wu, John <[John.Wu@ottawa.ca](mailto:John.Wu@ottawa.ca)>

**Cc:** Paradis, Kelly <[Kelly.Paradis@parsons.com](mailto:Kelly.Paradis@parsons.com)>

**Subject:** RE: CF Rideau Registry Site Plan Development - Boundary Conditions

Sensitive

Hi John,

I was not aware that the City would only provide one scenario.

Can you please provide the boundary conditions for one connection from Nicholas and one connection from Daly.

Regards,

Sarah

**SARAH MITCHELSON, P.ENG**

Municipal Engineer

1223 Michael Street North, Suite 100, Ottawa, ON K1J 7T2

[sarah.mitchelson@parsons.com](mailto:sarah.mitchelson@parsons.com)

Direct: +1 613.691.1609 / Mobile: +1 613.698.6705

[Parsons \[can01.safelinks.protection.outlook.com\] \[can01.safelinks.protection.outlook.com\]](#) / [LinkedIn](#)

[\[can01.safelinks.protection.outlook.com\] \[can01.safelinks.protection.outlook.com\]](#) / [Twitter](#)

[\[can01.safelinks.protection.outlook.com\] \[can01.safelinks.protection.outlook.com\]](#) / [Facebook](#)

[\[can01.safelinks.protection.outlook.com\] \[can01.safelinks.protection.outlook.com\]](#) / [Instagram](#)

[\[can01.safelinks.protection.outlook.com\] \[can01.safelinks.protection.outlook.com\]](#)



---

**From:** Wu, John <[John.Wu@ottawa.ca](mailto:John.Wu@ottawa.ca)>

**Sent:** Tuesday, October 12, 2021 11:25 AM

**To:** Mitchelson, Sarah <[Sarah.Mitchelson@parsons.com](mailto:Sarah.Mitchelson@parsons.com)>

**Subject:** [EXTERNAL] RE: CF Rideau Registry Site Plan Development - Boundary Conditions

Hi, Sarah:

We only do one scenario like your, one form 400 water main on Nicholas, and one from 400 on Daly.

Thanks.

John

---

**From:** Mitchelson, Sarah <[Sarah.Mitchelson@parsons.com](mailto:Sarah.Mitchelson@parsons.com)>  
**Sent:** October 7, 2021 6:03 PM  
**To:** Wu, John <[John.Wu@ottawa.ca](mailto:John.Wu@ottawa.ca)>  
**Cc:** Paradis, Kelly <[Kelly.Paradis@parsons.com](mailto:Kelly.Paradis@parsons.com)>  
**Subject:** CF Rideau Registry Site Plan Development - Boundary Conditions

**CAUTION: This email originated from an External Sender. Please do not click links or open attachments unless you recognize the source.**

**ATTENTION : Ce courriel provient d'un expéditeur externe. Ne cliquez sur aucun lien et n'ouvrez pas de pièce jointe, excepté si vous connaissez l'expéditeur.**

Sensitive

Hi John,

We are working on the site plan application for the proposed CF Rideau Registry development at the corner of Nicholas Street and Daly Avenue, a pre-application consultation meeting was held earlier this year.

We would like to request the boundary conditions for the following three (3) connection scenarios:

- Two (2) Water Service Connections to the existing 406mm watermain on Nicholas Street
- Two (2) Water Service Connections to the existing 406mm watermain on Daly Avenue
- One (1) Water Service Connection to the existing 406mm watermain on Nicholas Street and One (1) Water Service Connection to the existing 406mm watermain on Daly Avenue

The attached figure shows the proposed connection scenarios.

We can then identify which connection scenario is feasible/preferred and proceed with the design accordingly.

The demands are as follows:

- Average Day Demand = 2.4L/s
- Maximum Day Demand = 8.7L/s
- Peak Hour Demand = 13.5L/s
- Fire Demand = 400L/s

We are aware that the existing 406mm watermain on Daly Avenue is private and the City may only be able to provide the boundary conditions at the intersection of Nicholas Street and Daly Avenue.

Please advise if any additional information is required.

Regards,  
Sarah

**SARAH MITCHELSON, P.ENG**

Municipal Engineer

1223 Michael Street North, Suite 100, Ottawa, ON K1J 7T2

[sarah.mitchelson@parsons.com](mailto:sarah.mitchelson@parsons.com)

Direct: +1 613.691.1609 / Mobile: +1 613.698.6705

[Parsons \[can01.safelinks.protection.outlook.com\]](#) [[can01.safelinks.protection.outlook.com](#)]

[\[can01.safelinks.protection.outlook.com\]](#) / [LinkedIn \[can01.safelinks.protection.outlook.com\]](#)

[\[can01.safelinks.protection.outlook.com\]](#) [\[can01.safelinks.protection.outlook.com\]](#) / Twitter  
[\[can01.safelinks.protection.outlook.com\]](#) [\[can01.safelinks.protection.outlook.com\]](#)  
[\[can01.safelinks.protection.outlook.com\]](#) / Facebook [\[can01.safelinks.protection.outlook.com\]](#)  
[\[can01.safelinks.protection.outlook.com\]](#) [\[can01.safelinks.protection.outlook.com\]](#) / Instagram  
[\[can01.safelinks.protection.outlook.com\]](#) [\[can01.safelinks.protection.outlook.com\]](#)  
[\[can01.safelinks.protection.outlook.com\]](#)



'NOTICE: This email message and all attachments transmitted with it may contain privileged and confidential information, and information that is protected by, and proprietary to, Parsons Corporation, and is intended solely for the use of the addressee for the specific purpose set forth in this communication. If the reader of this message is not the intended recipient, you are hereby notified that any reading, dissemination, distribution, copying, or other use of this message or its attachments is strictly prohibited, and you should delete this message and all copies and backups thereof. The recipient may not further distribute or use any of the information contained herein without the express written authorization of the sender. If you have received this message in error, or if you have any questions regarding the use of the proprietary information contained therein, please contact the sender of this message immediately, and the sender will provide you with further instructions.'

This e-mail originates from the City of Ottawa e-mail system. Any distribution, use or copying of this e-mail or the information it contains by other than the intended recipient(s) is unauthorized. Thank you.

Le présent courriel a été expédié par le système de courriels de la Ville d'Ottawa. Toute distribution, utilisation ou reproduction du courriel ou des renseignements qui s'y trouvent par une personne autre que son destinataire prévu est interdite. Je vous remercie de votre collaboration.

This e-mail originates from the City of Ottawa e-mail system. Any distribution, use or copying of this e-mail or the information it contains by other than the intended recipient(s) is unauthorized. Thank you.

Le présent courriel a été expédié par le système de courriels de la Ville d'Ottawa. Toute distribution, utilisation ou reproduction du courriel ou des renseignements qui s'y trouvent par une personne autre que son destinataire prévu est interdite. Je vous remercie de votre collaboration.

This e-mail originates from the City of Ottawa e-mail system. Any distribution, use or copying of this e-mail or the information it contains by other than the intended recipient(s) is unauthorized. Thank you.

Le présent courriel a été expédié par le système de courriels de la Ville d'Ottawa. Toute distribution, utilisation ou reproduction du courriel ou des renseignements qui s'y trouvent par une personne autre que son destinataire prévu est interdite. Je vous remercie de votre collaboration.

# Boundary Conditions for CF Rideau Centre Condo Development

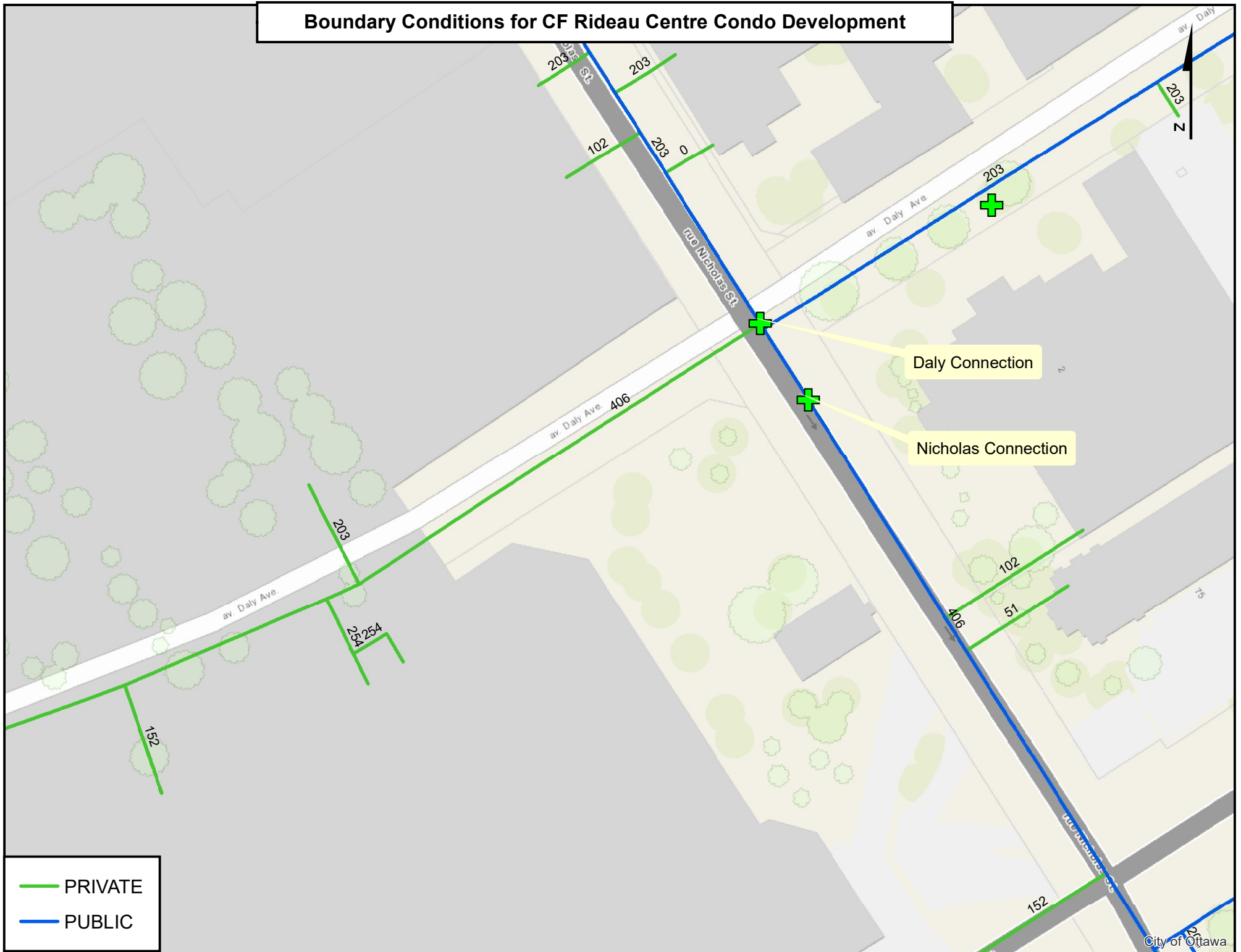

## APPENDIX E | WATER CALCULATIONS

**TABLE 1 : ESTIMATED WATER DEMANDS**

Building	Units	Population	Gross Floor Area (m2)	Average Daily Demand (ADD)*	Maximum Daily Demand (MDD)**	Peak Hourly Demand (PHD)**	Fire Flow (FF)	MDD + FF
				L/s	3.0*ADD 1.5*ADD (non-residential) L/s	4.5*ADD 1.8*MDD (non-residential) L/s		
<b>Rideau</b>				<b>2.37</b>	<b>7.11</b>	<b>10.67</b>	<b>67.00</b>	<b>74.11</b>
Residential - 1 Bedroom	181	253		0.82	2.46	3.70		
Residential - 2 Bedroom	106	223		0.72	2.16	3.25		
Amenity Space			400	0.02	0.07	0.10		
Outdoor Amenity Space			1270	0.07	0.22	0.33		
Retail*		470	470	0.68	2.04	3.06		
Commercial			550	0.05	0.15	0.23		

\* There are retail spaces proposed on the ground floor that will be rented. The future tenants are unknown at this time but restaurant and café uses are likely. To be conservative, worst case scenario of all three of these retail spaces being used for restaurants/café was assumed.

**Average Daily Demands**

Based on Ottawa Design Guidelines - Water Distribution, 2010 and MOE Design Guidelines for Drinking-Water Systems, 2008

Average Residential Daily Flow = 280 L/p/d  
 Restaurant (Ordinary not 24h) 125 L/seat/d  
 Amenity Area Flow = 5 L/m2/d  
 Office Daily Flow = 75 L/empl/d  
 8.06 L/m2/d (1 seat per 9.3m2)

\*\* Residential Peaking factors as per MOE Guidelines for Drinking-Water Systems Table 3-3 for 0 to 500 persons

**Population Densities**

Apartment average 1.8 p./unit  
 Bachelor 1.4 p./unit  
 1 Bedroom 1.4 p./unit  
 2 Bedrooms 2.1 p./unit  
 3 Bedrooms 3.1 p./unit  
 Restaurant 1 seat/m2

Unit Summary	1BR	1BR+	1BR++	2BR	2BRC	2BR+	TOTAL
TOTAL	69	35	77	34	55	17	287
Unit Mix	24%	12%	27%	12%	19%	6%	100%
Persons Per Unit	1.4	1.4	1.4	2.1	2.1	2.1	
Population	97	49	108	71	116	36	<b>476</b>

**TABLE 2: FIRE DEMAND CALCULATION (FUS)**

Building	Type of Construction	Total Floor Area	Fire Flow (Min. 2,000)	Adjusted (Nearest 1,000)	Occupancy Factor	Reduction / Increase due to Occupancy	Fire Flow with Occupancy (Min. 2,000)	Sprinklers Factor	Reduction due to Sprinklers	Exposure Factor	Increase due to Exposure	Fire Flow	Roof Contribution	Required Fire Flow	
														Adjusted (Nearest 1000) (Min. 2,000) (Max. 45,000)	(Min. 33) (Max. 750)
	C	m <sup>2</sup> A	L/min F	L/min	O		L/min	S	L/min	% E	L/min	L/min	L/min R	L/min F	L/s
Bedeau	0.6	1,533	5,168	5,000	-15%	-750	4,250	50%	2,125	50%	2,125	4,000	0	4,000	67

**References**  
 Water Supply for Public Fire Protection, 2020 by Fire Underwriters Survey (FUS) and Ottawa Design Guidelines - Water Distribution, July 2010 and subsequent Technical Bulletins

**C Type of Construction**

Wood Frame (Type V)	1.5
Mass Timber (Type IV-A) - Encapsulated Mass Timber	0.8
Mass Timber (Type IV-B) - Rated Mass Timber	0.9
Mass Timber (Type IV-C) - Ordinary Mass Timber	1.0
Mass Timber (Type IV-D) - Unrated Mass Timber	1.5
Ordinary Construction (Type III also known as joisted masonry)	1.0
Non-Combustible Construction (Type II - minimum 1 hour fire resistance rating)	0.8
Fire resistive Construction (Type I - minimum 2 hour fire resistance rating)	0.6

**S Sprinklers**

	Complete Coverage	Partial Coverage
Automatic Sprinklers NFPA Standards	30%	30% * x%
Standard Water Supply	10%	10% * x%
Full Supervision	10%	10% * x%

(x%: percentage of total protected floor area)

**Additional Reductions for Community Level Automatic Sprinkler Protection of Area**

Buildings located within communities or subdivisions that are completely sprinkler protected may apply up to a maximum additional 25% reduction in required fire flows beyond the normal maximum of 50% reduction for sprinkler protection of an individual building.

**Adjustment of Sprinkler Reductions for Community Level Oversight of Sprinkler Maintenance, Testing, and Water Supply Requirements**

The reduction in required fire flow for sprinkler protection may be reduced or eliminated if:  
 - The community does not have a Fire Prevention Program that provides a system of ensuring that the fire sprinkler systems are inspected, tested, and maintained in accordance with NFPA 25  
 - The community does not maintain the pressure and flow rate requirements for fire sprinkler installations, or otherwise allows the flow rates and pressure levels that were available during sprinkler system design to significantly degrade, increasing the probability of inadequate water supply for effective sprinkler operation.

**E Exposure**

The maximum exposure adjustment that can be applied to a building is 75% when summing the percentages of all sides of the building.

Separation Distance (m)	Maximum Exposure Adjustment	N	E	S	W
0 to 3	25%				X
3.1 to 10	20%				
10.1 to 20	15%	X			
20.1 to 30	10%		X		
Greater than 30	0%				

**Table 6: Exposure Adjustment Charges for Subject Building Considering Construction Type of Exposed Building Face**

Distance to the Exposure (m)	Length-Height Factor of Exposing Building Face	Type V	Type III-IV <sup>2</sup>	Type III-IV <sup>3</sup>	Type II <sup>2</sup>	Type I-II <sup>3</sup>
0 to 3	0-20	20%	15%	5%	10%	0%
	21-40	21%	16%	6%	11%	1%
	41-60	22%	17%	7%	12%	2%
	61-80	23%	18%	8%	13%	3%
	81-100	24%	19%	9%	14%	4%
	Over 100	25%	20%	10%	15%	5%
3.1 to 10	0-20	15%	10%	3%	6%	0%
	21-40	16%	11%	4%	7%	0%
	41-60	17%	12%	5%	8%	1%
	61-80	18%	13%	6%	9%	2%
	81-100	19%	14%	7%	10%	3%
	Over 100	20%	15%	8%	11%	4%
10.1 to 20	0-20	10%	5%	0%	3%	0%
	21-40	11%	6%	1%	4%	0%
	41-60	12%	7%	2%	5%	0%
	61-80	13%	8%	3%	6%	1%
	81-100	14%	9%	4%	7%	2%
	Over 100	15%	10%	5%	8%	3%
20.1 to 30	0-20	0%	0%	0%	0%	0%
	21-40	2%	1%	0%	0%	0%
	41-60	4%	2%	0%	1%	0%
	61-80	6%	3%	1%	2%	0%
	81-100	8%	4%	2%	3%	0%
	Over 100	10%	5%	3%	4%	0%
Over 30m	All Sizes	0%	0%	0%	0%	0%

<sup>2</sup> with unprotected openings  
<sup>3</sup> without unprotected openings

**Automatic Sprinkler Protection in Exposed Buildings**

- If the exposed building is fully protected with an automatic sprinkler system (see note Recognition of Automatic Sprinkler), the exposure adjustment charge determined from Table 6 may be reduced by up to 50% of the value determined.

**Automatic Sprinkler Protection in both Subject and Exposed Buildings**

- If both the subject building and the exposed building are fully protected with automatic sprinkler systems (see note Recognition of Automatic Sprinkler), no exposure adjustment charge should be applied.

**Exposure Protection of Area Between Subject and Exposed Buildings**

- If the exposed building is protected with an automatic sprinkler system (see note Recognition of Automatic Sprinkler), and the area between the buildings is protected with an exterior automatic sprinkler system, no exposure adjustment charge should be applied.

**Reduction of Exposure Charge for Type V Buildings**

- If the exposed building face of a Type V building has an exterior cladding assembly with a minimum 1 hour fire resistive rating, then the exposure charge may be treated as a Type II/IV building for the purposes of looking up the appropriate exposure charge in Table 6.

**A Total Effective Floor Area (m<sup>2</sup>)**

**Buildings Classified with a Construction Coefficient from 1.0 to 1.5**  
 100% of all Floor Areas

**Buildings Classified with a Construction Coefficient below 1.0**

- Vertical Openings Unprotected
  - Two (2) Largest Adjoining Floor Areas
  - Additional Floors (up to eight (8)) at 50%
- Vertical Openings Properly Protected
  - Single Largest Floor
  - Additional Two (2) Adjoining Floors at 25%

**High One Storey Building**

When a building has a large single storey space exceeding 3m in height, the number of storeys to be used in determining the total effective area depends upon the use being made of the building.

**Subdividing Buildings (Vertical Firewalls)**

Minimum two (2) hour fire resistance rating and meets National Building Code requirements.

- Up to 10% can be applied if there is severe risk of fire on the exposed side of the firewall due to hazard conditions.

- An exposure charge of up to 10% can be applied if there are unprotected openings in the firewall

**Basement**

Basement floor excluded when it is at least 50% below grade.

**Open Parking Garages**

Use the area of the largest floor.

**O Occupancy**

Non-Combustible	-25%
Limited Combustible	-15%
Combustible	0%
Free Burning	15%
Rapid Burning	25%

- Table 3 provides recommended Occupancy and Contents Adjustment Factors for Example Major Occupancies from the National Building Code of Canada.

- Adjustment factors should be adjusted accordingly to the specific fire loading and situation that exists in the subject building.

- Values can be interpolated from the examples given considering fire loading and expected combustibility of contents if the subject building is not listed.

- Values can be modified by up to 10% (+/-) depending on the extent to which the fire loading is unusual for the building.

- Buildings with multiple major occupancies should use the most restrictive factor or interpolate based on the percentage of each occupancy and its associated fire loading.

**Table 3 Values for Subject Building**

Group:	F
Division:	3
Description of Occupancy:	Storage Garage including Open Air Parking Garage
Occupancy and Contents:	Combustible
Adjustment Factor:	0%

**R Roof**

Shake Roof	2,000 to 4,000 L/min	additional should be added to the fire flow
Wood Shingle	2,000 to 4,000 L/min	additional should be added to the fire flow

**F Fire Flow (L/Min)**

$220 \times C^{\frac{1}{4}} \times A^{0.5}$

### TABLE 3: HAZEN-WILLIAMS HEAD LOSS CALCULATIONS

$$h_l = c \cdot V^{1.85} L / (C1.85 D^{1.165})$$

Rideau Nicholas Connections*	Boundary Condition		Description								Demand Results		
	Head (m)	Elevation at Boundary Condition (m)	Pipe Segment Length (m)	Diameter (mm)	Demand (L/s)	Hazen Williams Coefficient, C	Area (m <sup>2</sup> )	Velocity (m/s)	Unit Conversion, K	Elevation at Building Connection (m)	Head loss (m)	Pressure (kPa)	Pressure (psi)
<b>Peak Hour Demand</b>	106.40	65.96	11.50	150	10.67	110	0.0177	0.60	6.79	66.25	0.0464	393	57
<b>Average Daily Demand</b>	106.40	65.96	11.50	150	2.37	110	0.0177	0.13	6.79	66.25	0.0029	393	57
<b>Max Day + Fire Flow Demand</b>	109.40	65.96	11.50	150	74.11	110	0.0177	4.19	6.79	66.25	1.6733	406	59

\*Connection to the 406mm diameter watermain on Nicholas Street

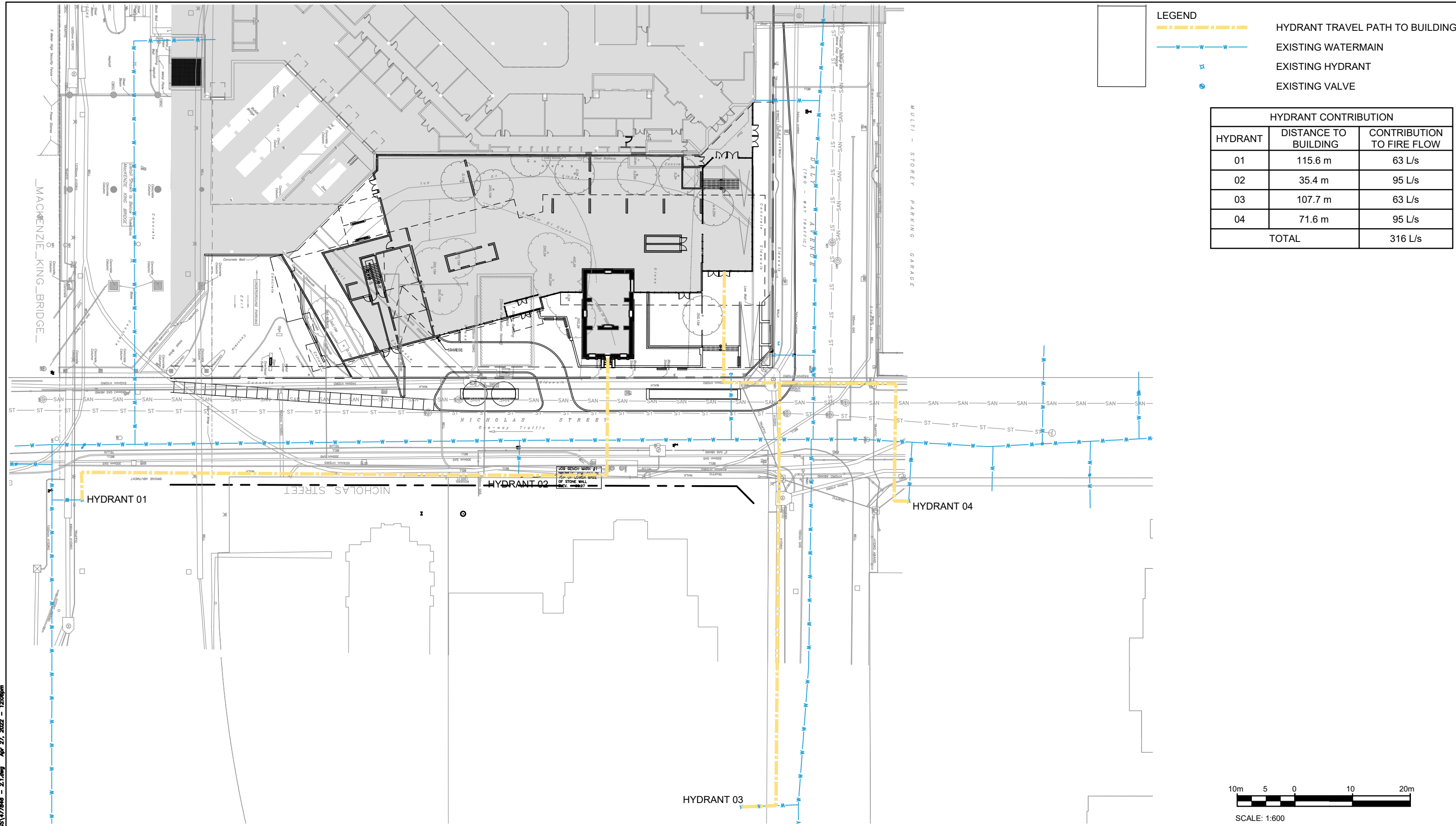

**LEGEND**

- - - HYDRANT TRAVEL PATH TO BUILDING
- W - EXISTING WATERMAIN
- H EXISTING HYDRANT
- V EXISTING VALVE

HYDRANT CONTRIBUTION		
HYDRANT	DISTANCE TO BUILDING	CONTRIBUTION TO FIRE FLOW
01	115.6 m	63 L/s
02	35.4 m	95 L/s
03	107.7 m	63 L/s
04	71.6 m	95 L/s
<b>TOTAL</b>		<b>316 L/s</b>

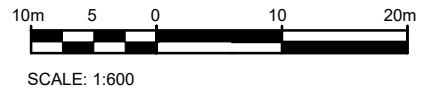

H:\201\477846\1000\DWG\477846 - 2.1.dwg Apr 27, 2022 - 12:06pm



**RIDEAU CENTER REGISTRY SITE  
OTTAWA, ON**

**HYDRANT CONTRIBUTION**

April, 2022  
477846  
FIGURE C

# NEUF



## ARCHITECT(E)S

City of Ottawa

Montreal, August 18, 2022

Second Floor  
101 CentrepoinTE Drive  
Nepean, Ontario K2G 5K7

**SUBJECT : Rideau Registry Site – 70 Nicholas Stree**

**Ref.: File Number: D07-12-21-0197 and Plan No. 18624**

To whom it may concern,

This letter serves to clarify the outstanding items to meet the FUS 2020 Guide, to complete the Response Letter for 70 Nicholas Rideau Registry Site project.

In conformance with Ontario Building Code (OBC), the building will be designed with a 2-hour fire resistance between floors, all loadbearing walls, columns and arches will have a fire-resistance rating not less than that required for the supported assembly *and will be designed* as noncombustible construction (with reference to the article 3.2.2.42).

As per the definitions of the OBC, «*Noncombustible construction means a type of construction in which a degree of fire safety is attained by the use of noncombustible materials for structural members and other building assemblies.*» (Article 1.4.1.2.)

With reference to the FUS 2020 Guide, the building could be considered as Fire-Resistive Construction (Type 1), where all structural elements are constructed with a 2-hour fire resistance rating.

In addition, the vertical openings built into the fire separation shall be protected in accordance with Ontario Building Code. In addition, the building will contain a fully monitored automatic sprinkler system.

If you have any comments or concerns, please contact the undersigned,

Chris Iig, O.A.Q., O.A.A.  
Partner, Architect



**APPENDIX F | SANITARY CALCULATIONS**

**TABLE 1: ESTIMATED SANITARY DEMANDS**

Area	Commercial Space					Restaurant					Residential					Amenity Space				Total	Infiltration			Total
	Area	Commercial	Average Flow	Peak Factor	Peak Flow	Area	Numbers of Seats	Average Flow	Peak Factor	Peak Flow	Number of Units	Capita	Average Flow	Peak Factor	Peak Flow	Area	Average Flow	Peak Factor	Peak Flow	Peak Flow	Site Area	Infiltration Allowance	Infiltration Flow	Total Peak Flow
	(m <sup>2</sup> )	L/m2/day	(L/s)		(L/s)	(m <sup>2</sup> )	(each)	(L/seat/s)		L/s	(each)	(each)	(L/s)		(L/s)	(m <sup>2</sup> )	(L/s)		(L/s)	(L/s)	(ha)	(L/s/ha)	(L/s)	(L/s)
<b>Proposed Building</b>																								
Residential - 1 Bedroom										181	253	0.82	3.5	2.86						2.86	0.27	0.33	0.09	0.09
Residential - 2 Bedroom										106	223	0.72	3.5	2.53						2.53				2.53
Retail (Assumed Restaurant)						470	470	0.68	1.50	1.02										1.02				1.02
Outdoor Amenity Space															1270	0.07	1.5	0.11	0.11					0.11
Indoor Amenity Space															400	0.02	1.5	0.03	0.03					0.03
Commercial (Gym & Leasing Office)	550	8.06	0.05	1.50	0.08															0.08				0.08
																								<b>TOTAL</b>
																								<b>6.72</b>
<b>Average Daily Demands</b>	<b>Peak Factors</b>					<b>Infiltration Allowance</b>					<b>Population Densities</b>				<b>Design:</b>	<b>Project:</b>								
(Based on City of Ottawa Sewer Design Guidelines 2012 and MOE Water Design Guidelines)	Commercial =	1.5		if commercial contribution > 20%, otherwise	1.0						Infiltration allowance (dry)		0.05	L/s/ha	Average Suburban	60	p/ha	SM	Rideau					
	Institutional =	1.5		if institutional contribution > 20%, otherwise	1.0						Infiltration allowance (wet)		0.28	L/s/ha	Single Family	3.4	p/unit	<b>Check :</b>	<b>Location:</b>					
Average Residential Daily Flow =	280	L/p/d		Industrial =							Infiltration allowance (total)		0.33	L/s/ha	Semi-Detached	2.7	p/unit	<b>Project # :</b>	477846					
Institutional Flow =	28,000	L/gross ha/d		Residential =	Harmon	1 + (14/(4+(Capita/1000)^0.5))*0.8									Duplex	2.3	p/unit	<b>Date:</b>	April 2022					
Commercial Flow =	28,000	L/gross ha/d				Minimum = 2									Townhouse	2.7	p/unit	<b>Sheet:</b>	1 of 1					
Light Industrial Flow =	35,000	L/gross ha/d				Maximum = 4									Apartment Averag	1.8	p/unit							
Heavy Industrial Flow =	55,000	L/gross ha/d													Bachelor	1.4	p/unit							
Restaurant (Ordinary not 24 Hours) =	125	L/seat/d													1 Bedroom	1.4	p/unit							
Amenity Area =	5	L/m2/d													2 Bedrooms	2.1	p/unit							
Commercial =	75	L/person/d													3 Bedrooms	3.1	p/unit							
	8.06	L/m2/day													Hotel Room, 18 m	1	p/unit							
															Restaurant, 1 m2	1	p/unit							
															Office	1	p/25m <sup>2</sup>							

**TABLE 2: SANITARY SEWER COMPUTATIONS**

Drainage Area	From	To	Peak Flow Q (L/sec)	Type of Pipe	Sewer Data								REMARKS	
					Pipe Dia.		Slope*	Length	Capacity	Velocity		Time of		Q(d) / Q(f)
					nom. (mm)	actual (mm)	(%)	(m)	full (L/sec)	full (m/sec)	actual (m/sec)	Flow (min)		
Rideau	Building	Sanitary	6.72	Transite	150	150	2.0	4.9	21.5	1.22	0.90	0.09	0.31	
Manning's n = 0.013 * Min slope for cleansing velocities is 0.32% Estimated Invert @ Building Wall = 63.66m Estimated Invert Top of Bend @ Connection Point = 63.56m										<b>Design:</b> SM <b>Check:</b> KP <b>Date:</b> April 2022	<b>Project Name:</b> Rideau <b>Parsons Project #:</b> 477846 <b>Client:</b> Cadillac Fairview			

**APPENDIX G | STORM CALCULATIONS & DRAINAGE PLANS**

**TABLE 1 - PRE-DEVELOPMENT AVERAGE RUNOFF COEFFICIENTS**

Watershed Area No.	Roof/Asphalt Areas (m <sup>2</sup> )	A * C <sub>ASPH/ROOF</sub>	Gravel Areas (m <sup>2</sup> )	A * C <sub>GRAVEL</sub>	Grass Areas (m <sup>2</sup> )	A * C <sub>GRASS</sub>	Sum AC	Total Area (m <sup>2</sup> )	C <sub>AVG (5yr)</sub>	C <sub>AVG(100yr)</sub>
EWS-A	140.13	126	174.34	122	1545.53	309	557	1860	0.30	0.37
EWS-B	291.00	262	0.00	0	512.00	102	364	803	0.45	0.57
EWS-C	36.39	33	0.00	0	0.00	0	33	36	0.90	1.00
Total	468		174		2058		954	2699		

**TABLE 2 - ALLOWABLE RUNOFF CALCULATIONS BASED ON PRE-EXISTING CONDITIONS**

Area Description	Area (ha)	Time of Conc, Tc (min)	Minor Storm				Storm = 100 yr			
				I <sub>5</sub> (mm/hr)	C <sub>AVG</sub>	Q <sub>ALLOW</sub> (L/s)	I <sub>100</sub> (mm/hr)	C <sub>AVG</sub>	Q <sub>ALLOW</sub> (L/sec)	
EWS-A	0.186	10	Storm = 5 yr	104.19	0.30	16.1	178.56	0.37	34.6	
EWS-B	0.080	10	Storm = 5 yr	104.19	0.45	10.6	178.56	0.57	22.6	
EWS-C	0.004	10	Storm = 5 yr	104.19	0.50	0.5	178.56	1.00	1.8	
						<b>27.2</b>				

Allowable Capture Rate is based on the 5-Year storm at T<sub>c</sub>=10 mins, and a C value of 0.5 or less

5-year Storm	C <sub>ASPH/ROOF/CONC</sub> =	0.90	C <sub>GRAVEL</sub> =	0.70	C <sub>GRASS</sub> =	0.20
100-year Storm	C <sub>ASPH/ROOF/CONC</sub> =	1.00	C <sub>GRAVEL</sub> =	0.88	C <sub>GRASS</sub> =	0.25

**TABLE 3 - POST-DEVELOPMENT AVERAGE RUNOFF COEFFICIENTS**

Watershed Area No.	Roof/Asphalt Areas (m <sup>2</sup> )	A * C <sub>ASPH/ROOF</sub>	Gravel Areas (m <sup>2</sup> )	A * C <sub>GRAVEL</sub>	Grass Areas (m <sup>2</sup> )	A * C <sub>GRASS</sub>	Sum AC	Total Area (m <sup>2</sup> )	C <sub>AVG (5yr)</sub>	C <sub>AVG(100yr)</sub>
WS-01*	102.80	93	0.00	0	0.00	0	93	103	0.90	1.00
WS-02*	249.60	225	0.00	0	0.00	0	225	250	0.90	1.00
WS-03*	322.10	290	0.00	0	0.00	0	290	322	0.90	1.00
WS-04*	801.00	721	0.00	0	0.00	0	721	801	0.90	1.00
WS-05*	754.60	679	0.00	0	0.00	0	679	755	0.90	1.00
WS-06*	94.20	85	0.00	0	0.00	0	85	94	0.90	1.00
WS-07**	112.60	101	0.00	0	0.00	0	101	113	0.90	1.00
WS-08**	151.90	137	0.00	0	29.00	6	143	181	0.79	0.98
WS-09	248.10	223	0.00	0	73.90	15	238	322	0.74	0.92
WS-10	47.80	43	0.00	0	2.90	1	44	51	0.86	1.00
Total	2885		0		106		2617	2991		
Total Controlled	2589		0		106		2336	2618		

\*Uncontrolled roof drains directed to cistern

\*\*Uncontrolled ground surface directed to cistern

**TABLE 4 - TOTAL RUNOFF COEFFICIENT FOR CONTROLLED AREAS**

C <sub>AVG(5yr)</sub> =	Sum AC	=	2,336	=	0.89	C <sub>AVG(100yr)</sub> =	1.00
	Total Area		2,618				

**TABLE 5 - SUMMARY OF POST-DEVELOPMENT RUNOFF**

Area No	Area (ha)	Storm = 5 yr				Storm = 100 yr			
		I <sub>5</sub> (mm/hr)	C <sub>AVG(5yr)</sub>	Q <sub>GEN</sub> (L/s)	Q <sub>CONT</sub> (L/s)	I <sub>100</sub> (mm/hr)	C <sub>AVG(100yr)</sub>	Q <sub>GEN</sub> (L/s)	Q <sub>CONT</sub> (L/s)
WS-01*	0.010	104.19	0.90	2.7	9.9	178.56	1.00	5.1	9.9
WS-02*	0.025	104.19	0.90	6.5		178.56	1.00	12.4	
WS-03*	0.032	104.19	0.90	8.4		178.56	1.00	16.0	
WS-04*	0.080	104.19	0.90	20.9		178.56	1.00	39.8	
WS-05*	0.075	104.19	0.90	19.7		178.56	1.00	37.5	
WS-06*	0.009	104.19	0.90	2.5		178.56	1.00	4.7	
WS-07**	0.011	104.19	0.90	2.9		178.56	1.00	5.6	
WS-08**	0.018	104.19	0.79	4.1		178.56	0.98	8.8	
WS-09	0.032	104.19	0.74	6.9	6.9	178.56	0.92	14.8	14.8
WS-10	0.005	104.19	0.86	1.3	1.3	178.56	1.00	2.5	2.5
<b>Total</b>	0.299			75.8	<b>11.2</b>			147.1	<b>27.2</b>

\*Uncontrolled roof drains directed to cistern

\*\*Uncontrolled ground surface directed to cistern

I<sub>5</sub> = 998.071 / (Tc + 6.053)<sup>0.814</sup>

I<sub>100</sub> = 1735.688 / (Tc + 6.014)<sup>0.820</sup>

Time of concentration (min), Tc = 10 mins

**TABLE 6 - STORAGE VOLUMES (5-YEAR, 100-YEAR and 100-YEAR STORM + 20% STRESS EVENTS)**

**STORAGE REQUIREMENT FOR UNCONTROLLED ROOF DRAINS AND GROUND LEVEL SPACE**

C<sub>AVG</sub> = 0.89 (5-year)  
 C<sub>AVG</sub> = 1.00 (100-year)  
 Time Interval = 5 (mins)  
 Drainage Area = 0.262 (hectares)

20% Stress Event

Duration (min)	Release Rate = 9.9 (L/sec) Return Period = 5 (years) IDF Parameters, A = 998.071, B = 0.814 I = A/(T <sub>c</sub> +C)/B, C = 6.053					Release Rate = 9.9 (L/sec) Return Period = 100 (years) IDF Parameters, A = 1735.688, B = 0.820 I = A/(T <sub>c</sub> +C)/B, C = 6.014					Release Rate = 9.9 (L/sec) Return Period = 100 (years) IDF Parameters, A = 1735.688, B = 0.820 I = A/(T <sub>c</sub> +C)/B, C = 6.014				
	Rainfall Intensity, I (mm/hr)	Peak Flow (L/sec)	Release Rate (L/sec)	Storage Rate (L/sec)	Storage (m <sup>3</sup> )	Rainfall Intensity, I (mm/hr)	Peak Flow (L/sec)	Release Rate (L/sec)	Storage Rate (L/sec)	Storage (m <sup>3</sup> )	Rainfall Intensity, I (mm/hr)	Peak Flow (L/sec)	Release Rate (L/sec)	Storage Rate (L/sec)	Storage (m <sup>3</sup> )
0	-	-	-	-	-	-	-	-	-	-	-	-	-	-	-
5	141.2	91.7	9.9	81.8	24.5	242.7	176.6	9.9	166.7	50.0	242.7	212.0	9.9	202.1	60.6
10	104.2	67.7	9.9	57.8	34.7	178.6	129.9	9.9	120.0	72.0	178.6	155.9	9.9	146.0	87.6
15	83.6	54.3	9.9	44.4	39.9	142.9	104.0	9.9	94.1	84.7	142.9	124.8	9.9	114.9	103.4
20	70.3	45.6	9.9	35.7	42.9	120.0	87.3	9.9	77.4	92.9	120.0	104.8	9.9	94.9	113.8
25	60.9	39.5	9.9	29.6	44.5	103.8	75.6	9.9	65.7	98.5	103.8	90.7	9.9	80.8	121.2
30	53.9	35.0	9.9	25.1	45.2	91.9	66.9	9.9	57.0	102.5	91.9	80.2	9.9	70.3	126.6
35	48.5	31.5	9.9	21.6	45.4	82.6	60.1	9.9	50.2	105.4	82.6	72.1	9.9	62.2	130.7
40	44.2	28.7	9.9	18.8	45.1	75.1	54.7	9.9	44.8	107.5	75.1	65.6	9.9	55.7	133.7
45	40.6	26.4	9.9	16.5	44.5	69.1	50.3	9.9	40.4	108.9	69.1	60.3	9.9	50.4	136.1
50	37.7	24.4	9.9	14.5	43.6	64.0	46.5	9.9	36.6	109.9	64.0	55.9	9.9	46.0	137.9
55	35.1	22.8	9.9	12.9	42.6	59.6	43.4	9.9	33.5	110.5	59.6	52.1	9.9	42.2	139.2
60	32.9	21.4	9.9	11.5	41.4	55.9	40.7	9.9	30.8	110.8	55.9	48.8	9.9	38.9	140.1
65	31.0	20.2	9.9	10.3	40.0	52.6	38.3	9.9	28.4	110.8	52.6	46.0	9.9	36.1	140.7
70	29.4	19.1	9.9	9.2	38.5	49.8	36.2	9.9	26.3	110.6	49.8	43.5	9.9	33.6	141.0
75	27.9	18.1	9.9	8.2	36.9	47.3	34.4	9.9	24.5	110.2	47.3	41.3	9.9	31.4	141.2
80	26.6	17.2	9.9	7.3	35.3	45.0	32.7	9.9	22.8	109.6	45.0	39.3	9.9	29.4	141.1
85	25.4	16.5	9.9	6.6	33.5	43.0	31.3	9.9	21.4	108.9	43.0	37.5	9.9	27.6	140.8
90	24.3	15.8	9.9	5.9	31.7	41.1	29.9	9.9	20.0	108.1	41.1	35.9	9.9	26.0	140.4
95	23.3	15.1	9.9	5.2	29.8	39.4	28.7	9.9	18.8	107.2	39.4	34.4	9.9	24.5	139.9
100	22.4	14.5	9.9	4.6	27.9	37.9	27.6	9.9	17.7	106.1	37.9	33.1	9.9	23.2	139.2
105	21.6	14.0	9.9	4.1	25.9	36.5	26.6	9.9	16.7	105.0	36.5	31.9	9.9	22.0	138.4
110	20.8	13.5	9.9	3.6	23.9	35.2	25.6	9.9	15.7	103.7	35.2	30.7	9.9	20.8	137.6
115	20.1	13.1	9.9	3.2	21.8	34.0	24.7	9.9	14.8	102.4	34.0	29.7	9.9	19.8	136.6
120	19.5	12.6	9.9	2.7	19.7	32.9	23.9	9.9	14.0	101.1	32.9	28.7	9.9	18.8	135.6
125	18.9	12.2	9.9	2.3	17.6	31.9	23.2	9.9	13.3	99.7	31.9	27.8	9.9	17.9	134.4
130	18.3	11.9	9.9	2.0	15.4	30.9	22.5	9.9	12.6	98.2	30.9	27.0	9.9	17.1	133.3
135	17.8	11.5	9.9	1.6	13.2	30.0	21.8	9.9	11.9	96.6	30.0	26.2	9.9	16.3	132.0
140	17.3	11.2	9.9	1.3	11.0	29.2	21.2	9.9	11.3	95.0	29.2	25.5	9.9	15.6	130.7
145	16.8	10.9	9.9	1.0	8.8	28.4	20.6	9.9	10.7	93.4	28.4	24.8	9.9	14.9	129.3
150	16.4	10.6	9.9	0.7	6.5	27.6	20.1	9.9	10.2	91.7	27.6	24.1	9.9	14.2	127.9
155	15.9	10.4	9.9	0.5	4.2	26.9	19.6	9.9	9.7	90.0	26.9	23.5	9.9	13.6	126.4
160	15.6	10.1	9.9	0.2	1.9	26.2	19.1	9.9	9.2	88.3	26.2	22.9	9.9	13.0	124.9
165	15.2	9.9	9.9	0.0	-0.4	25.6	18.6	9.9	8.7	86.5	25.6	22.4	9.9	12.5	123.4
170	14.8	9.6	9.9	-0.3	-2.7	25.0	18.2	9.9	8.3	84.7	25.0	21.8	9.9	11.9	121.8
175	14.5	9.4	9.9	-0.5	-5.1	24.4	17.8	9.9	7.9	82.8	24.4	21.3	9.9	11.4	120.2
180	14.2	9.2	9.9	-0.7	-7.5	23.9	17.4	9.9	7.5	80.9	23.9	20.9	9.9	11.0	118.5
185	13.9	9.0	9.9	-0.9	-9.9	23.4	17.0	9.9	7.1	79.0	23.4	20.4	9.9	10.5	116.8
190	13.6	8.8	9.9	-1.1	-12.3	22.9	16.7	9.9	6.8	77.1	22.9	20.0	9.9	10.1	115.1
195	13.3	8.6	9.9	-1.3	-14.7	22.4	16.3	9.9	6.4	75.2	22.4	19.6	9.9	9.7	113.3
200	13.0	8.5	9.9	-1.4	-17.1	22.0	16.0	9.9	6.1	73.2	22.0	19.2	9.9	9.3	111.6
205	12.8	8.3	9.9	-1.6	-19.6	21.6	15.7	9.9	5.8	71.2	21.6	18.8	9.9	8.9	109.8
210	12.6	8.2	9.9	-1.7	-22.0	21.1	15.4	9.9	5.5	69.1	21.1	18.5	9.9	8.6	107.9
215	12.3	8.0	9.9	-1.9	-24.5	20.8	15.1	9.9	5.2	67.1	20.8	18.1	9.9	8.2	106.1
220	12.1	7.9	9.9	-2.0	-27.0	20.4	14.8	9.9	4.9	65.0	20.4	17.8	9.9	7.9	104.2
225	11.9	7.7	9.9	-2.2	-29.4	20.0	14.6	9.9	4.7	63.0	20.0	17.5	9.9	7.6	102.3
230	11.7	7.6	9.9	-2.3	-31.9	19.7	14.3	9.9	4.4	60.9	19.7	17.2	9.9	7.3	100.4
235	11.5	7.5	9.9	-2.4	-34.4	19.3	14.1	9.9	4.2	58.7	19.3	16.9	9.9	7.0	98.4
240	11.3	7.3	9.9	-2.6	-37.0	19.0	13.8	9.9	3.9	56.6	19.0	16.6	9.9	6.7	96.4
245	11.1	7.2	9.9	-2.7	-39.5	18.7	13.6	9.9	3.7	54.5	18.7	16.3	9.9	6.4	94.5
250	10.9	7.1	9.9	-2.8	-42.0	18.4	13.4	9.9	3.5	52.3	18.4	16.1	9.9	6.2	92.5
255	10.8	7.0	9.9	-2.9	-44.5	18.1	13.2	9.9	3.3	50.1	18.1	15.8	9.9	5.9	90.4
260	10.6	6.9	9.9	-3.0	-47.1	17.8	13.0	9.9	3.1	47.9	17.8	15.6	9.9	5.7	88.4
265	10.4	6.8	9.9	-3.1	-49.6	17.6	12.8	9.9	2.9	45.7	17.6	15.3	9.9	5.4	86.4
270	10.3	6.7	9.9	-3.2	-52.2	17.3	12.6	9.9	2.7	43.5	17.3	15.1	9.9	5.2	84.3
275	10.1	6.6	9.9	-3.3	-54.8	17.0	12.4	9.9	2.5	41.3	17.0	14.9	9.9	5.0	82.2
280	10.0	6.5	9.9	-3.4	-57.3	16.8	12.2	9.9	2.3	39.0	16.8	14.7	9.9	4.8	80.1
285	9.9	6.4	9.9	-3.5	-59.9	16.6	12.1	9.9	2.2	36.8	16.6	14.5	9.9	4.6	78.0
290	9.7	6.3	9.9	-3.6	-62.5	16.3	11.9	9.9	2.0	34.5	16.3	14.3	9.9	4.4	75.9
295	9.6	6.2	9.9	-3.7	-65.1	16.1	11.7	9.9	1.8	32.3	16.1	14.1	9.9	4.2	73.8
300	9.5	6.1	9.9	-3.8	-67.7	15.9	11.6	9.9	1.7	30.0	15.9	13.9	9.9	4.0	71.6
Max =					<b>45.4</b>					<b>110.8</b>					<b>141.2</b>

- Notes**
- 1) Peak flow is equal to the product of 2.78 x C x I x A
  - 2) Rainfall Intensity, i = A/(T<sub>c</sub>/60)<sup>B</sup>
  - 3) Release Rate = LESSER of Min (Release Rate, Peak Flow) - Minus 100 Year Flow Of Uncontrolled Areas OR Pipe Outlet Capacity
  - 4) Storage Rate = Peak Flow - Release Rate
  - 5) Storage = Duration x Storage Rate
  - 6) Maximum Storage = Max Storage Over Duration

**TABLE 7 - STORM SEWER COMPUTATION FORM**

**Rational Method**  
 $Q = 2.78 * A * I * R$   
 Q = Flow (L/sec)  
 A = Area (ha)  
 I = Rainfall Intensity (mm/h)  
 R = Ave. Runoff Coefficient

**Ottawa IDF Curve - 2-y**  
 $I_p = 998.071 / (T_c + 6.053)^{0.814}$   
 Minimum Time of Conc.  $T_c = 10$  min

Manning's n = **0.013**

Drainage Area	From	To	Area (ha)	Runoff Parameters					Roof Flow Q (L/sec)	Peak Flow Q (L/sec)	Pipe Dia.		Slope (%)	Length (m)	Capacity full (L/sec)	Velocity		Time of Flow (min)	Q(d) / Q(f)	REMARKS	
				Runoff Coeff. R	Indiv. 2.78AR	Accum. 2.78AR	Time of Conc. (min)	Rainfall Intensity (mm/hr)			nom. (mm)	actual (mm)				full (m/sec)	actual (m/sec)				
WS-01 to WS-06	Building	Sewer	0.259	0.89	0.64	0.64	10.00	104.19		9.9	200	200	2.00	9.1	46.38	1.48	1.00	0.10	0.21		
WS-07	Trench Drain	Building	0.011	0.90	0.03	0.03	10.00	104.19		2.9											*Piped internally through underground garage.
WS-08	Trench Drain	Building	0.018	0.79	0.04	0.04	10.00	104.19		4.1											*Piped internally through underground garage.

Note:  
 Allowable release rate  
 The minimum velocity when flowing full is greater than 0.80 m/s  
 Estimated Invert @ Building Wall = 61.19m  
 Estimated Invert Top of Bend @ Connection Point = 62.37m

**Design:** SM  
**Check:** KP  
**Date:** April 2022

**Project:** CF Rideau Centre Registry Site

HA10214776461.0001.DWG\$177846 - 2.1.dwg Apr 27, 2022 - 3:19pm

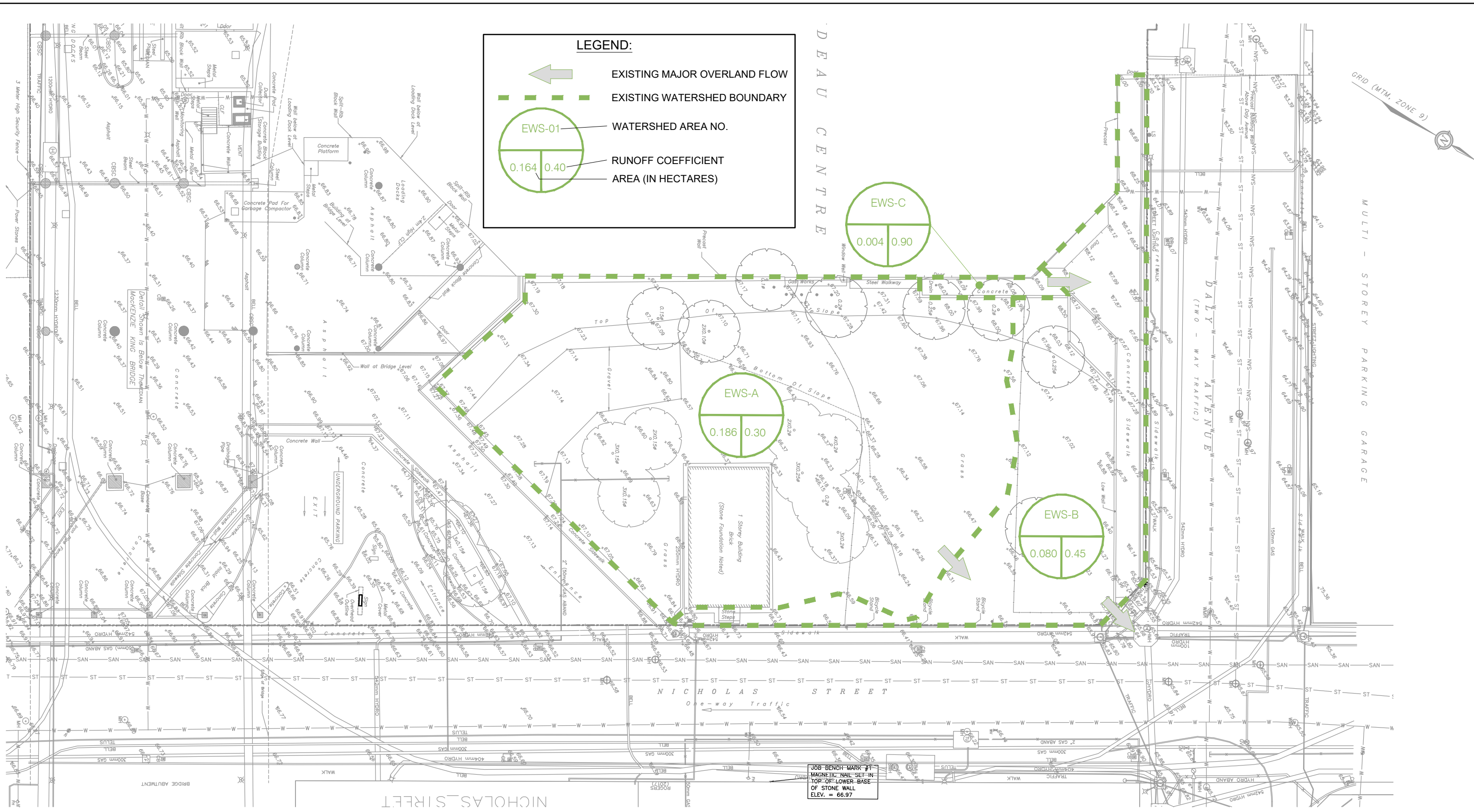

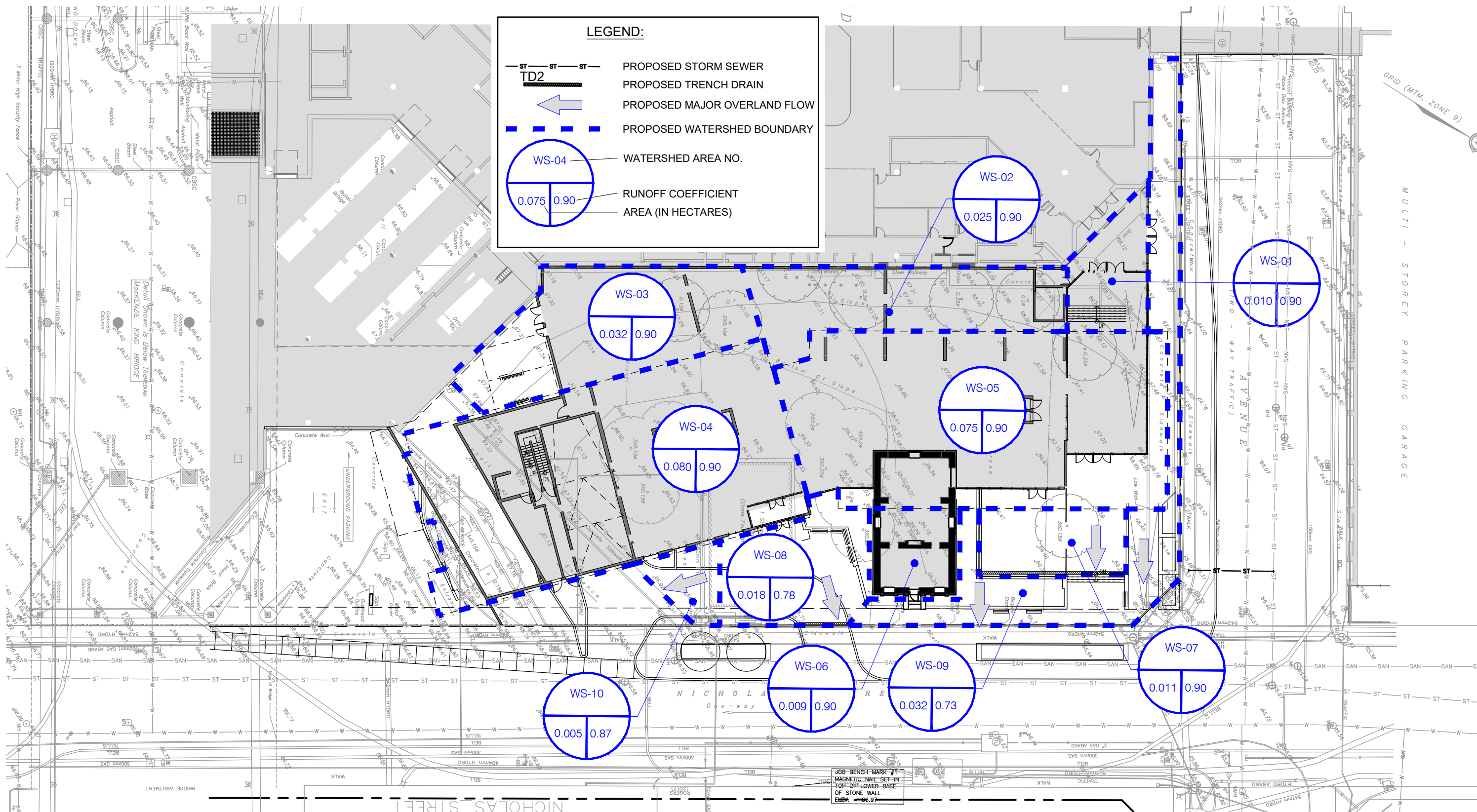

H:\1001\477846\1000\DWG\477846 - 2.1.dwg Apr 27, 2022 - 3:13pm