

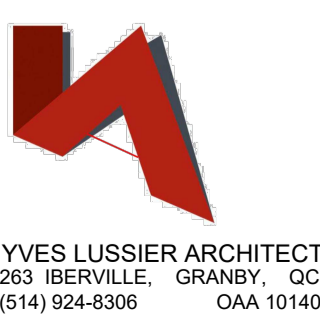

NO DE DOSSIER: 2020-117



RACINE ■ OTTAWA ■
630 Montréal Road, Ottawa, On

LOT 45 AND PART OF LOTS 3, 4 & 5, REGISTERED PLAN 343 (CITY OF OTTAWA)	
ACTUAL LAND AREA	970.77 M ² *
*AFTER CITY ROAD WIDENING	
BUILDING FOOTPRINT (GFA):	502.55 M ²
NUMBER OF DWELLINGS:	56 UNITS

PERSPECTIVES
A 01 | 18
REVISION 9 / 27-03-2024

007-12-21-0189

18965



RACINE ■ OTTAWA ■
 630 Montréal Road, Ottawa, On

LOT 45 AND PART OF LOTS 3, 4 & 5,
 REGISTERED PLAN 343 (CITY OF OTTAWA)
 ACTUAL LAND AREA 970.77 M²*
*AFTER CITY ROAD WIDENING
 BUILDING FOOTPRINT (GFA): 502.55 M²
 NUMBER OF DWELLINGS: 56 UNITS



RACINE ■ OTTAWA ■
630 Montréal Road, Ottawa, On

LOT 45 AND PART OF LOTS 3, 4 & 5,
REGISTERED PLAN 343 (CITY OF OTTAWA)
ACTUAL LAND AREA 970.77 M²*
*AFTER CITY ROAD WIDENING
BUILDING FOOTPRINT (GFA): 502.55 M²
NUMBER OF DWELLINGS: 56 UNITS



RACINE ■ OTTAWA ■
630 Montréal Road, Ottawa, On

LOT 45 AND PART OF LOTS 3, 4 & 5,
REGISTERED PLAN 343 (CITY OF OTTAWA)
ACTUAL LAND AREA 970.77 M²*
*AFTER CITY ROAD WIDENING
BUILDING FOOTPRINT (GFA): 502.55 M²
NUMBER OF DWELLINGS: 56 UNITS

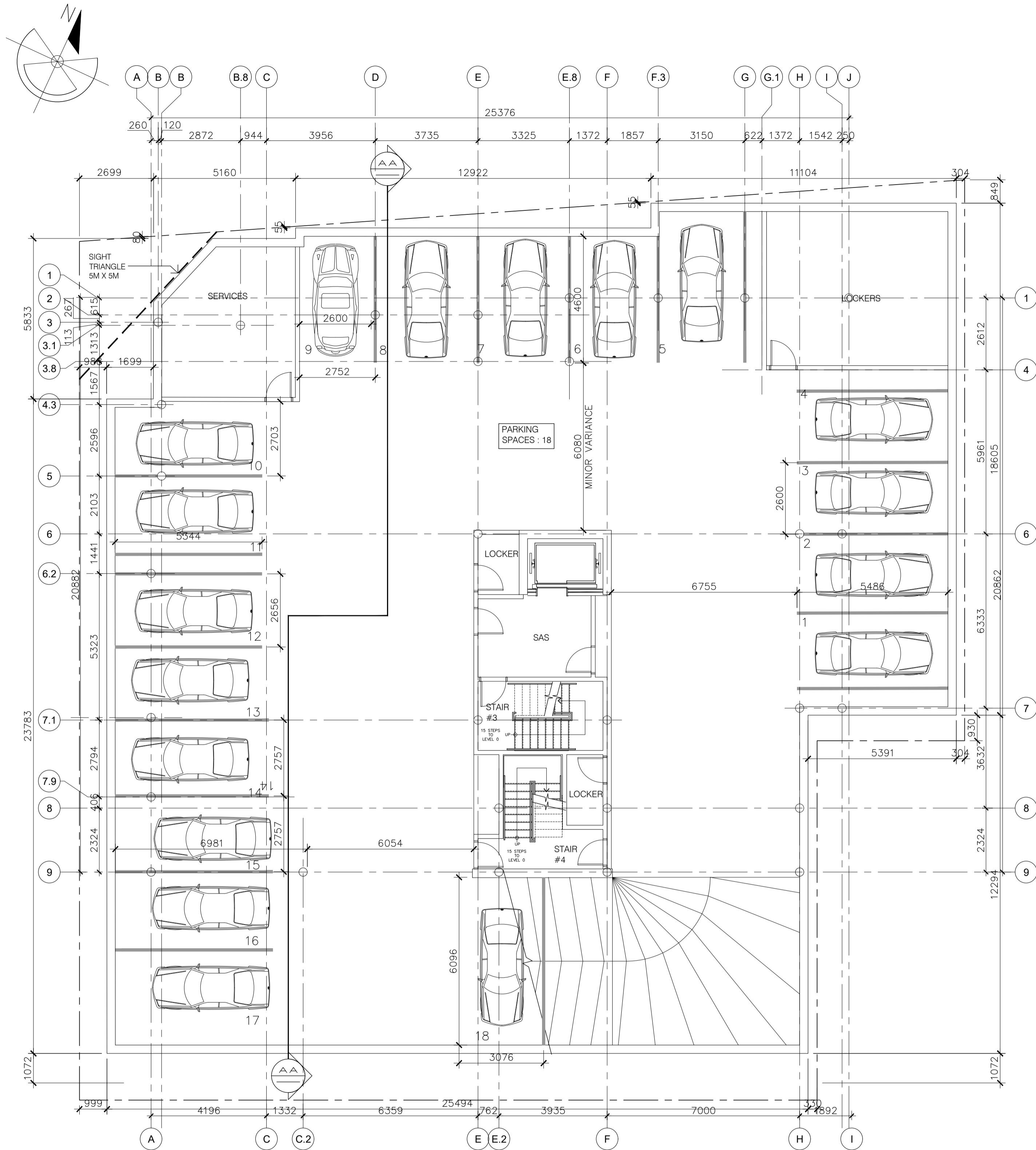

SECOND BASEMENT - LEVEL 00
SCALE = 1:100

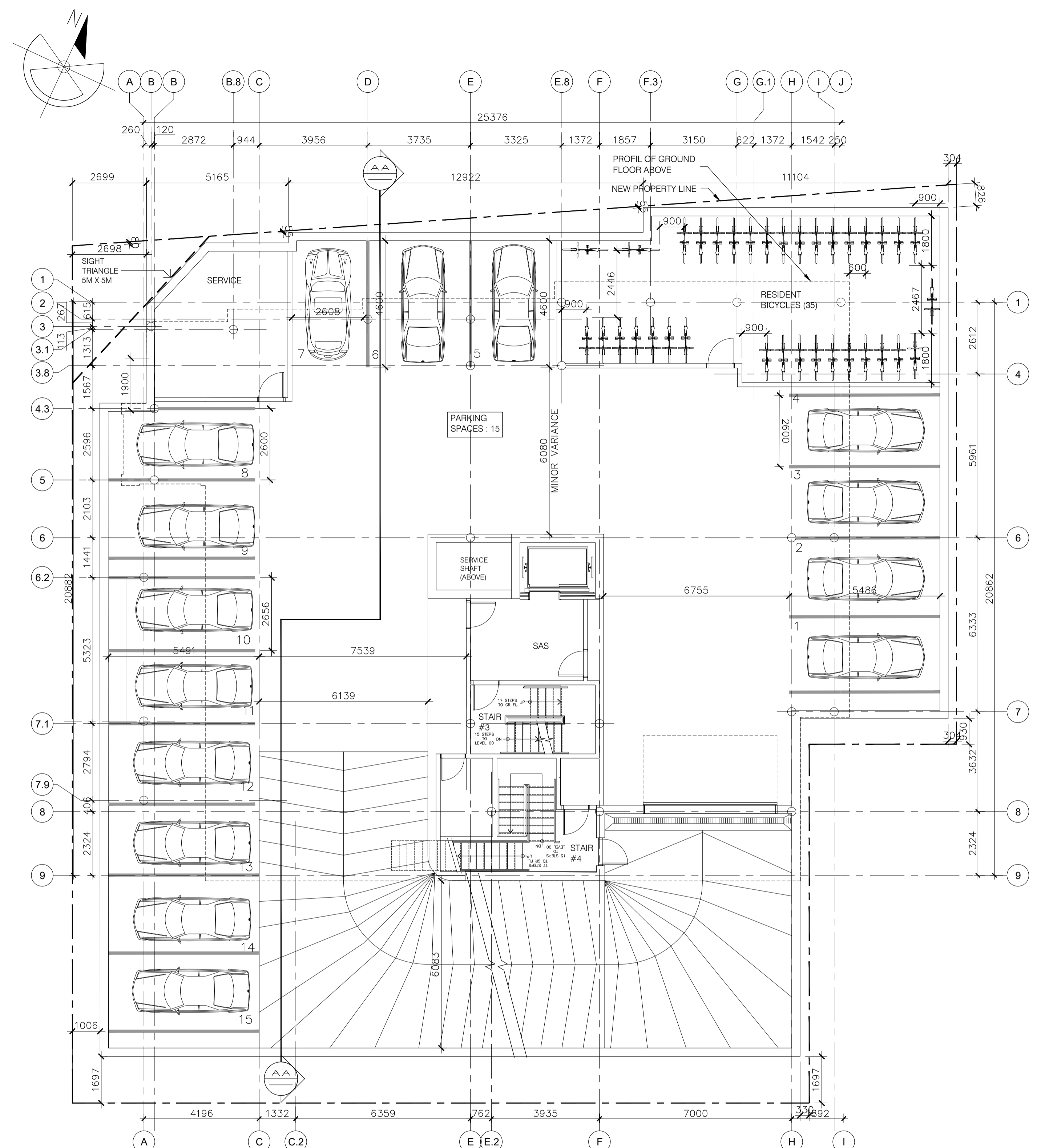

FIRST BASEMENT - LEVEL 01
SCALE - 1:100

USE	RATE	DWELLING UNITS	PARKING REQUIRED	BICYCLE REQUIRED
RESIDENTIAL, TENANT	0.5 PER DWELLING UNIT* <small>*NO PARKING IS REQUIRED FOR THE FIRST 12 UNITS</small>	44 UNITS	22	28
RESIDENTIAL, VISITOR	0.1 PER DWELLING UNIT* <small>*NO PARKING IS REQUIRED FOR THE FIRST 12 UNITS</small>	44 UNITS	4	-
RETAIL STORE	AREA LESS THEN 500 M ²	NONE REQUIRED	0	-
TOTAL REQUIRED			26	28
TOTAL PROJECTED:	TWO PARKING LEVELS		32	35

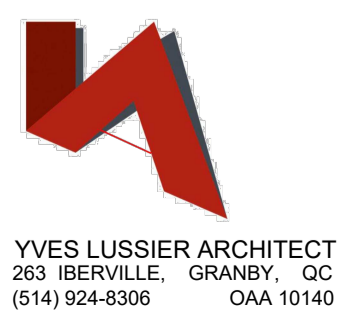

RACINE ■ OTTAWA ■
630 Montréal Road, Ottawa, On

LOT 45 AND PART OF LOTS 3, 4 & 5,
REGISTERED PLAN 343 (CITY OF OTTAWA)
ACTUAL LAND AREA 970.77 M²*
*AFTER CITY ROAD WIDENING
BUILDING FOOTPRINT (GFA): 502.55 M²
NUMBER OF DWELLINGS: 56 UNITS

PARKING LEVELS
A 06 | 18
REVISION 9 / 27-03-2024

007-12-21-0189
18965

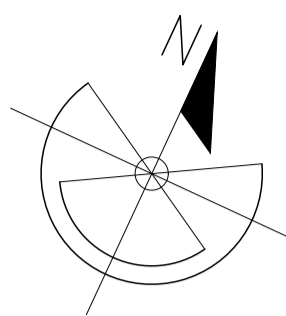

MONTREAL ROAD

AMENITY AREA FOR 54 UNITS:

COMMUNAL AMENITY	REQUIRED	SUPPLIED	TYPE
PRIVATE AMENITY (SMALLEST BALCONY AREA : 3.93 M ² X 56 UNITS = 220 M ²)	162 M ²	174 M ²	ROOF TERRACE
	162 M ²	220 M ²	PRIVATE BALCONIES
TOTAL	324 M²	394 M²	

Racine - Ottawa		2023-11-07		Type of unit	3 1/2	4 1/2	Floor area
Type of unit	3 1/2	4 1/2	Floor area	4th	5	2	536.48 m.c.
Area (intérieur)	Refer to plans			5th	5	2	536.48 m.c.
Ground floor	0	1	502.54 m.c.	6th	5	2	536.48 m.c.
1st	2	0	240.45 m.c.	7th	3	3	477.58 m.c.
2nd	5	2	536.48 m.c.	8th	3	3	477.58 m.c.
3thrd	5	2	536.48 m.c.	9th	4	2	473.34 m.c.
Total unit / type	37	19	Total floor area	Total of units	56		4853.89 m.c.

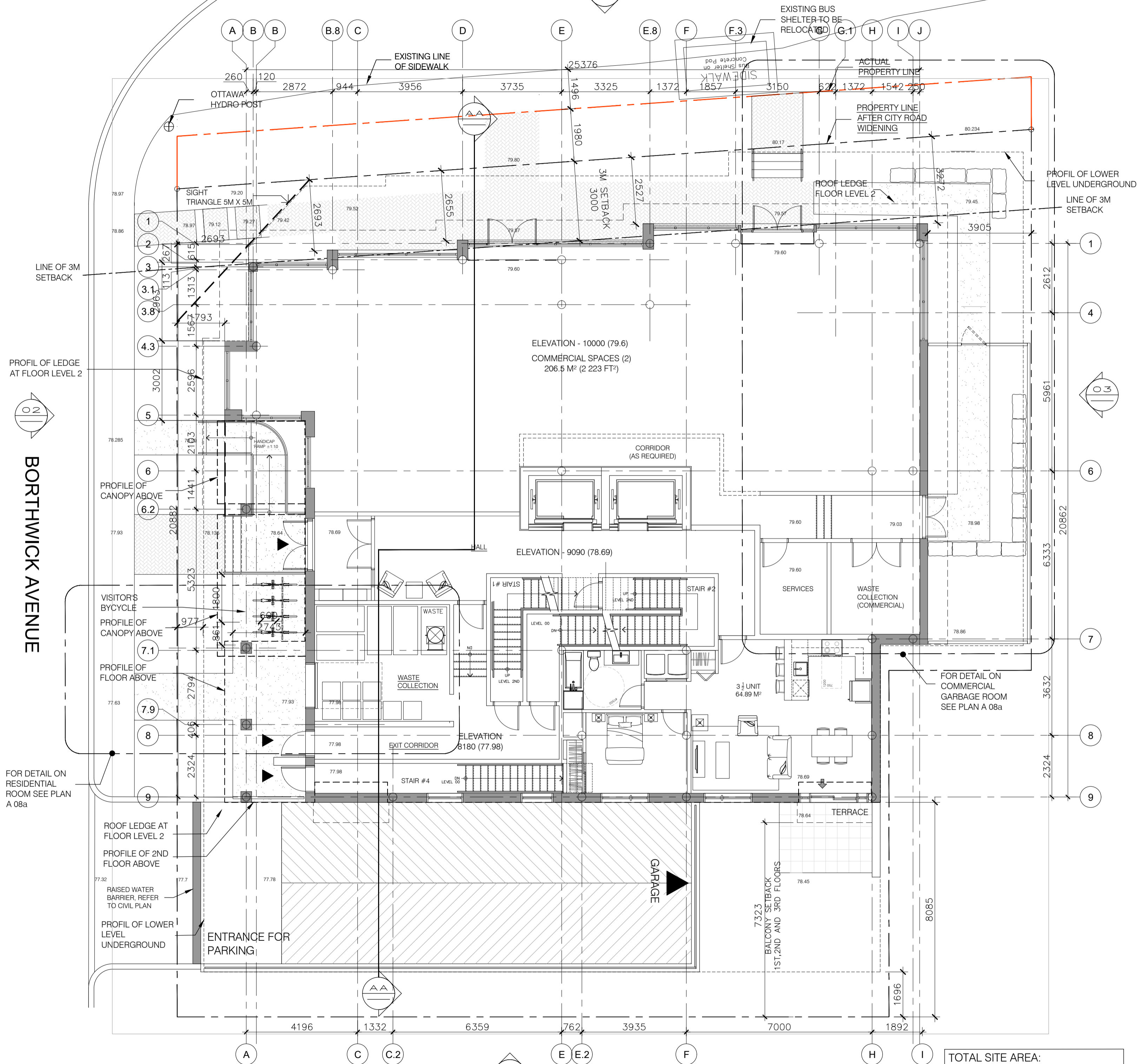

GROUND FLOOR
SCALE = 1:100

TOTAL SITE AREA:
1 034.49 M² (11 135 FT²)
FLOOR AREA AT GROUND LEVEL:
502.54 M² (5 409.3 FT²)

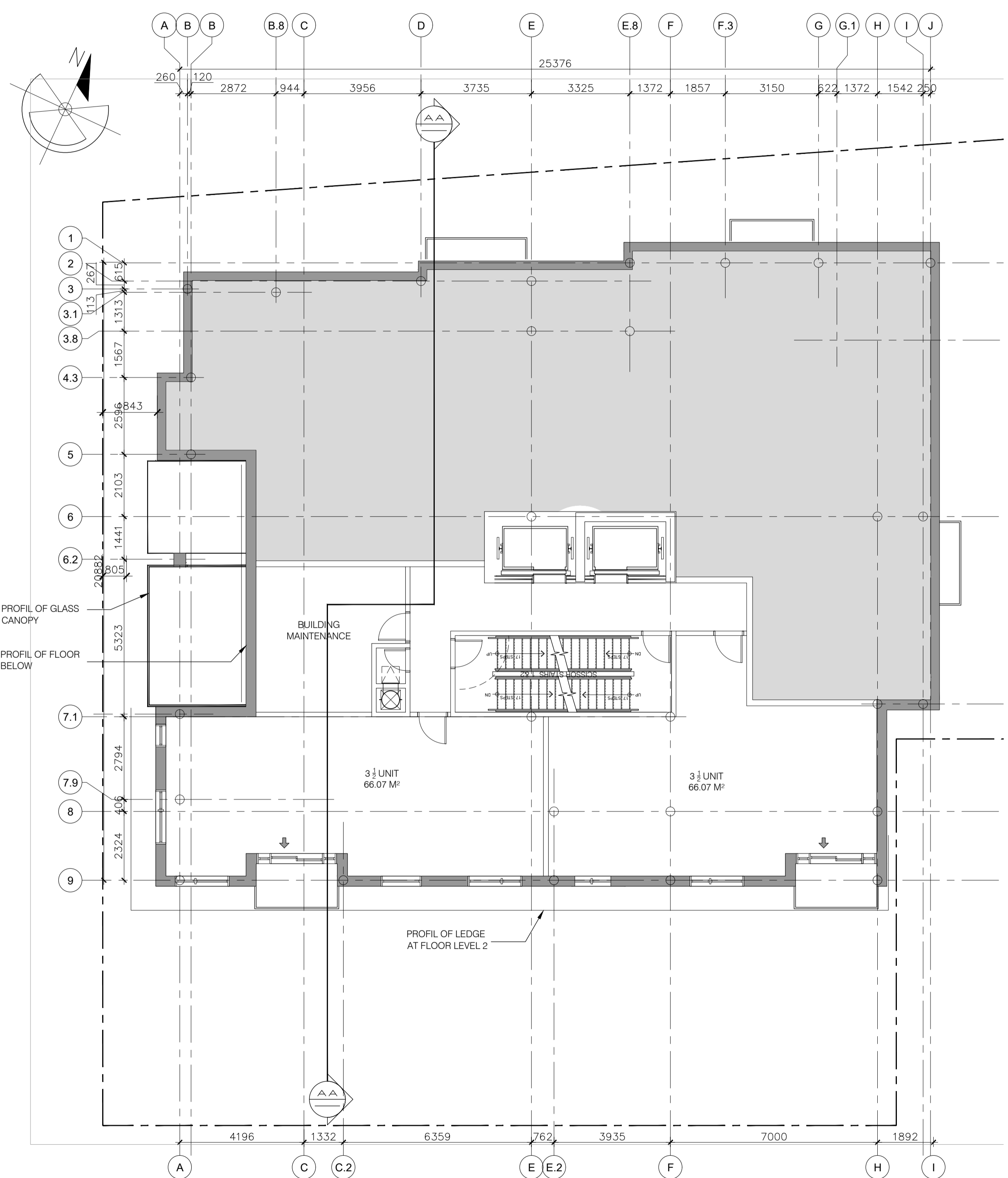

1ST FLOOR
SCALE = 1:100

MB Groupe Canada DEVELOPPER

Maitre dans l'art du développement immobilier

YVES LUSSIER ARCHITECT
263 IBERVILLE, GRANBY, QC
(514) 924-8306 OAA 10140

ONTARIO ASSOCIATION OF ARCHITECTS
YVES LUSSIER
LICENCE 10140

RACINE ■ OTTAWA ■
630 Montréal Road, Ottawa, On

LOT 45 AND PART OF LOTS 3, 4 & 5,
REGISTERED PLAN 343 (CITY OF OTTAWA)
ACTUAL LAND AREA 970.77 M²**
*AFTER CITY ROAD WIDENING
BUILDING FOOTPRINT (GFA): 502.55 M²
NUMBER OF DWELLINGS: 56 UNITS

GROUND FLOOR
A 07 | 18
REVISION 9 / 27-03-2024

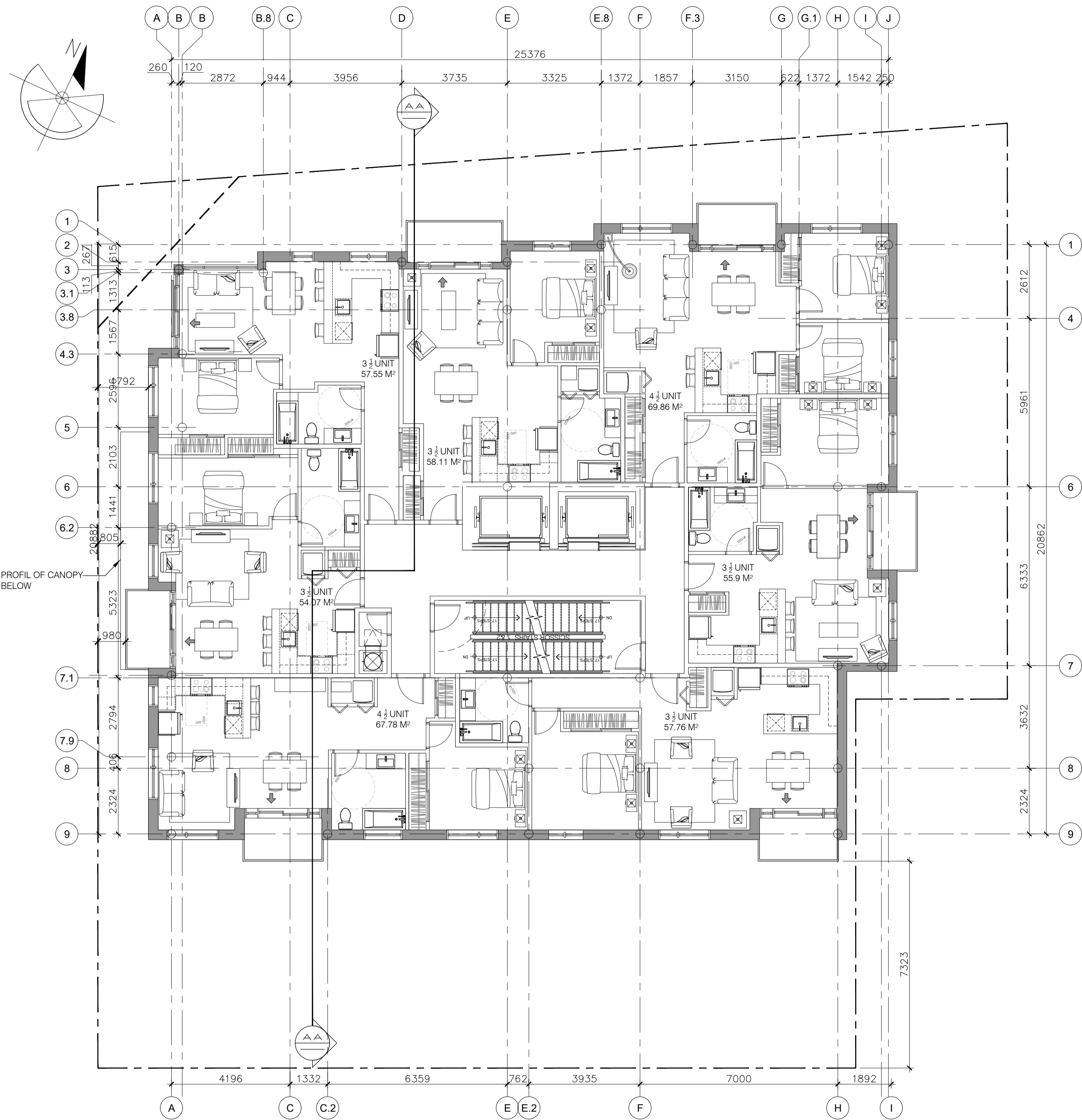

2TH FLOOR
SCALE = 1:100

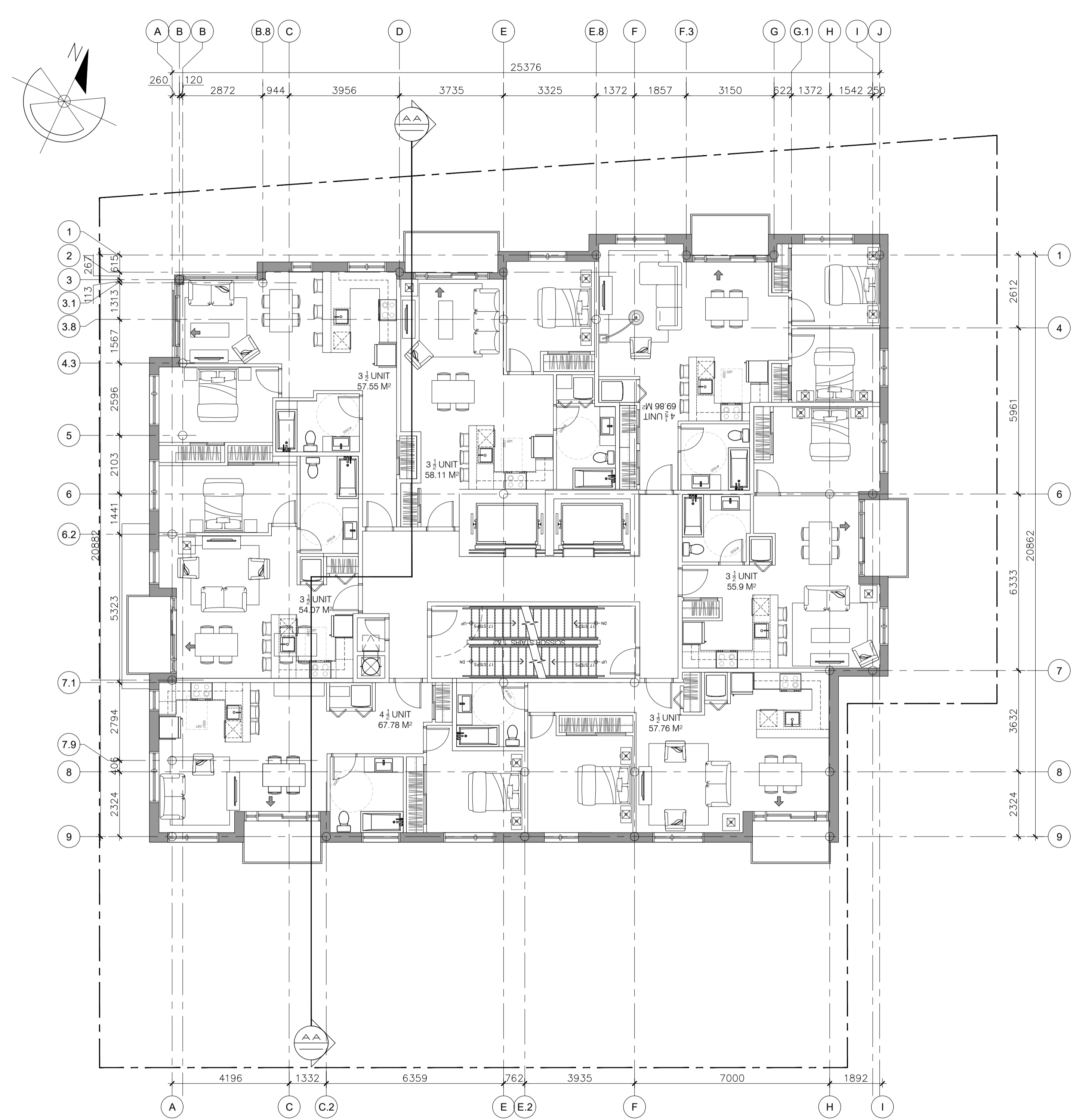

3RD to 6TH FLOOR
SCALE = 1:100

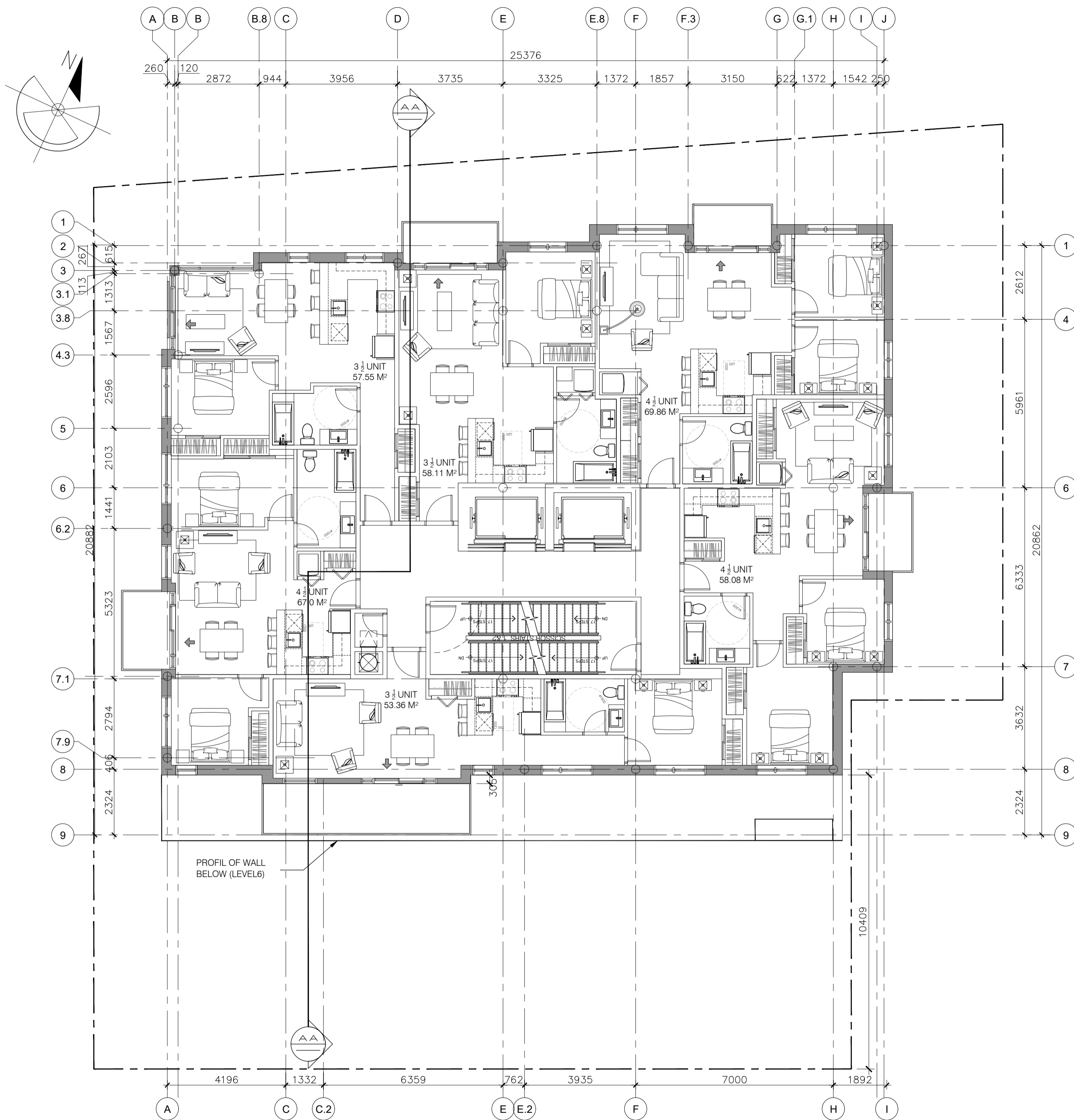

7TH FLOOR
SCALE = 1:100

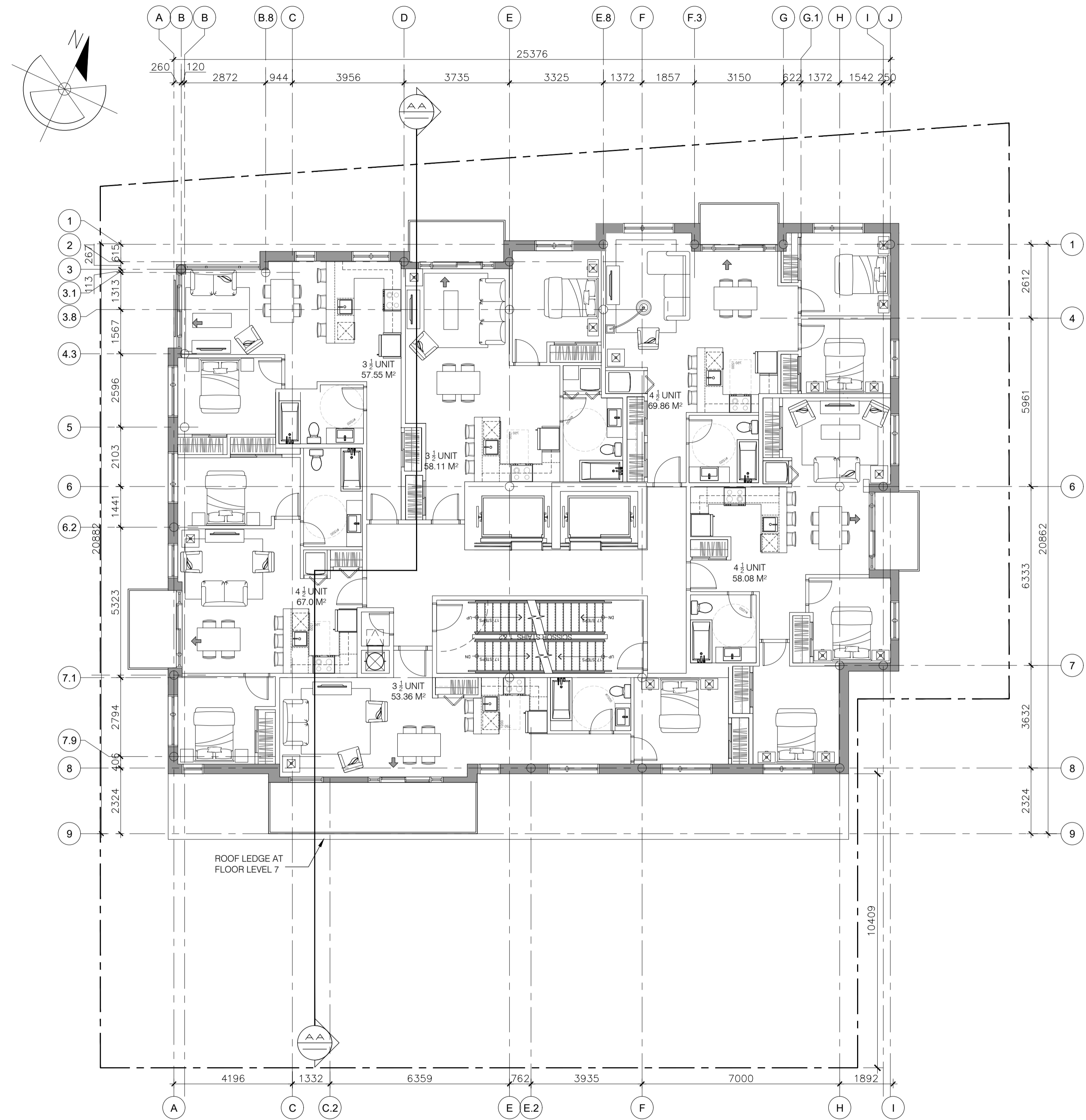

8TH FLOOR
SCALE = 1:100

NO DE DOSSIER: 2020-117

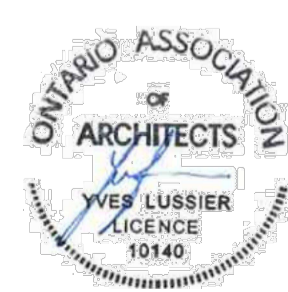
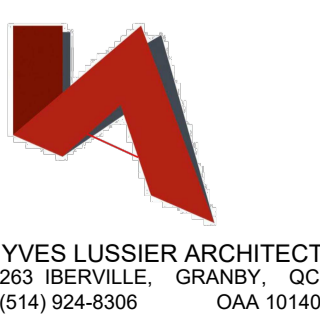

RACINE ■ OTTAWA ■
630 Montréal Road, Ottawa, On

LOT 45 AND PART OF LOTS 3, 4 & 5, REGISTERED PLAN 343 (CITY OF OTTAWA)	
ACTUAL LAND AREA	970.77 M ² *
*AFTER CITY ROAD WIDENING	
BUILDING FOOTPRINT (GFA):	502.55 M ²
NUMBER OF DWELLINGS:	56 UNITS

FLOORS 7 AND 8
A 09 | 18
REVISION 9 / 27-03-2024

007-12-21-0189
18965

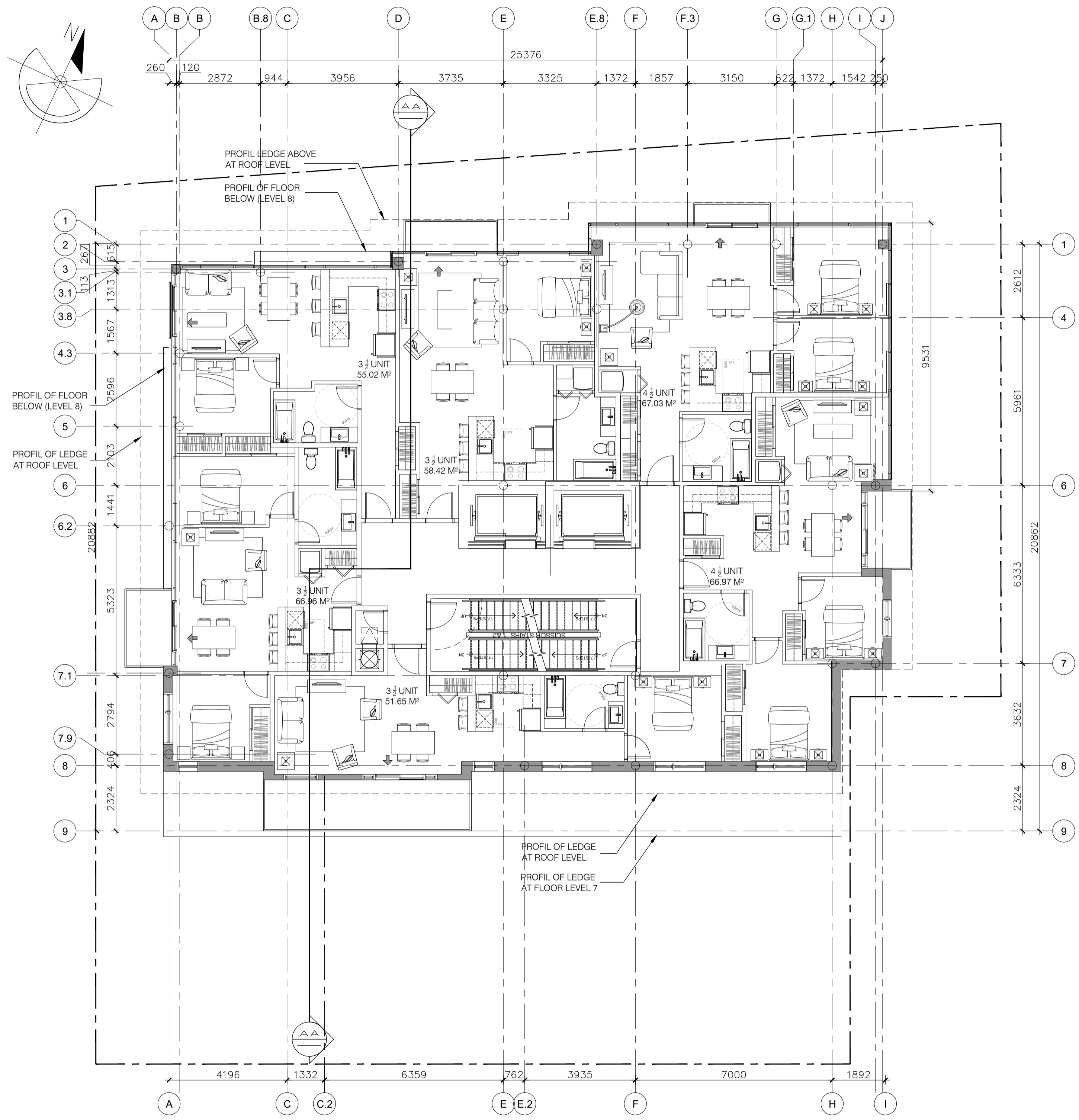

9TH FLOOR
SCALE = 1:100

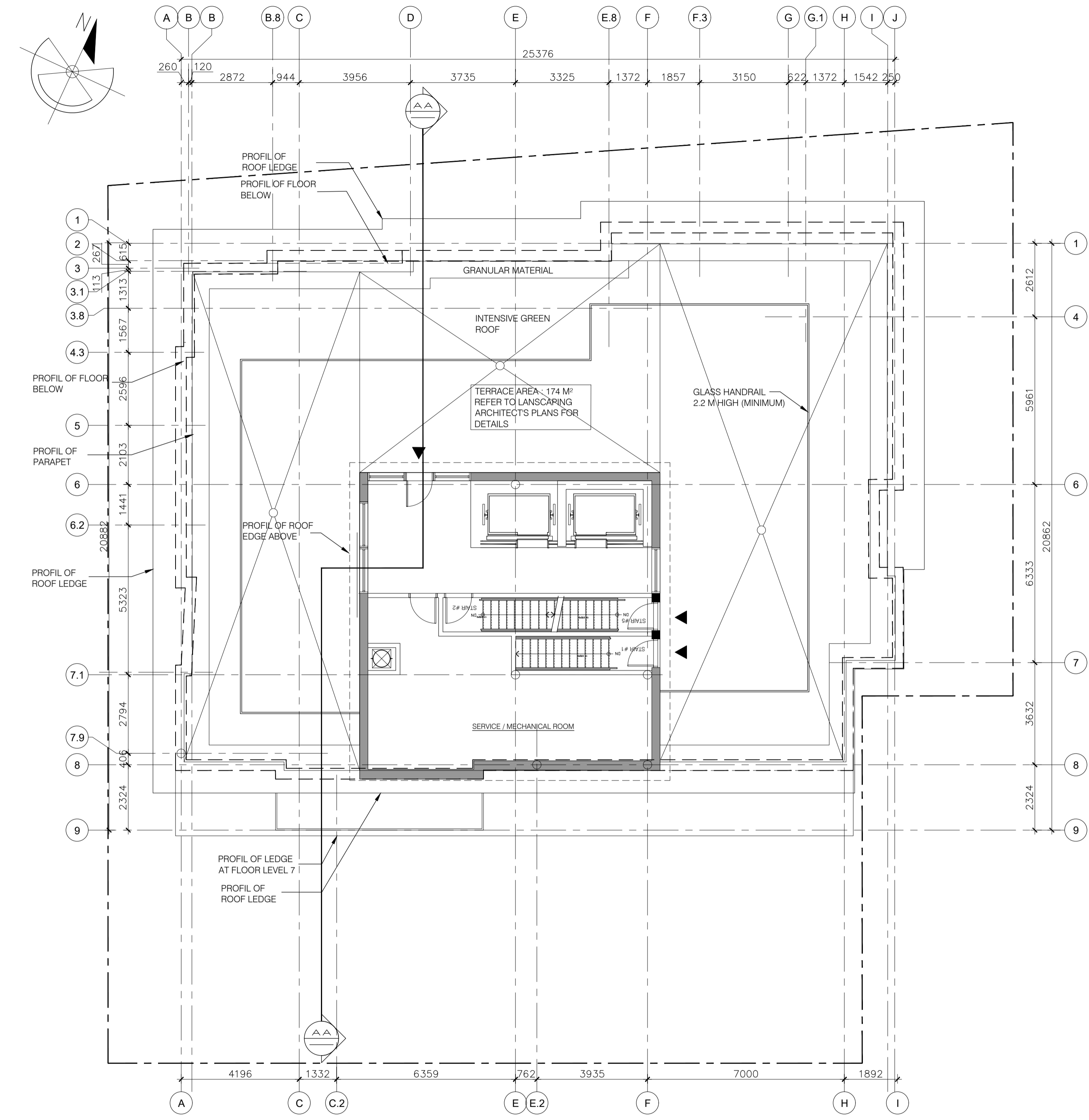

ROOF TERRACE
SCALE = 1:100

NO DE DOSSIER: 2020-117

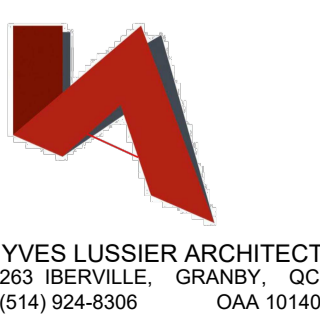

RACINE ■ OTTAWA ■
630 Montréal Road, Ottawa, On

LOT 45 AND PART OF LOTS 3, 4 & 5,
REGISTERED PLAN 343 (CITY OF OTTAWA)
ACTUAL LAND AREA 970.77 M²*
*AFTER CITY ROAD WIDENING
BUILDING FOOTPRINT (GFA): 502.55 M²
NUMBER OF DWELLINGS: 56 UNITS

FLOOR 9 AND TERRACE LEVEL
A 10 | 18
REVISION 9 / 27-03 - 2024

007-12-21-0189

18965

RACINE ■ OTTAWA ■
 630 Montréal Road, Ottawa, On

LOT 45 AND PART OF LOTS 3, 4 & 5,
 REGISTERED PLAN 343 (CITY OF OTTAWA)
 ACTUAL LAND AREA 970.77 M²*
 *AFTER CITY ROAD WIDENING
 BUILDING FOOTPRINT (GFA): 502.55 M²
 NUMBER OF DWELLINGS: 56 UNITS

ROOF LEVEL
 A 11 | 18
 REVISION 9 / 27-03-2024

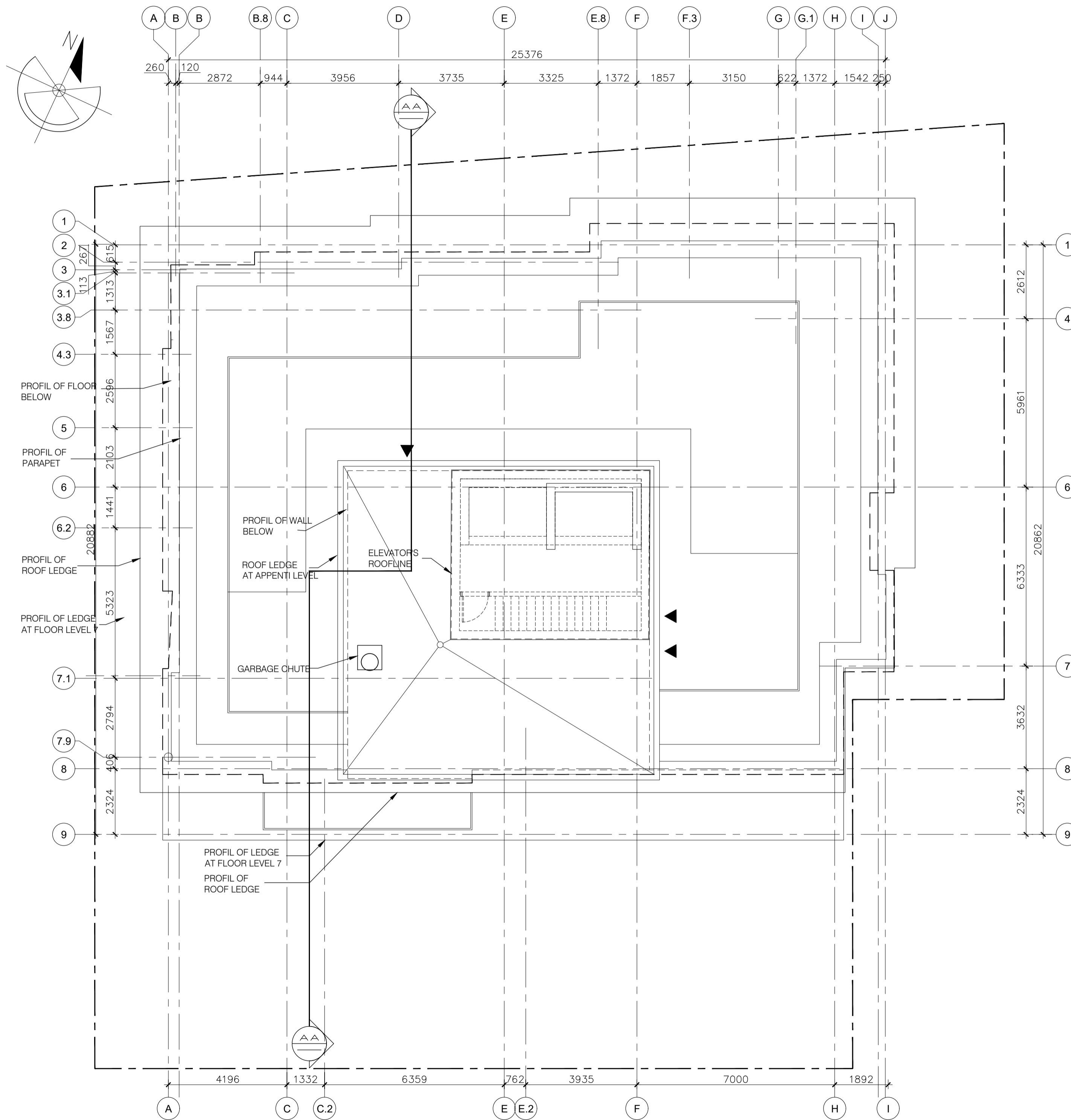

RESIDENTIAL - WASTE AND RECYCLING COLLECTION

RESIDENTIAL WASTE ARE COLLECTED THOUGH A GARBAGE CHUTE INTO A WASTE BIN LOCATED ON THE GROUND FLOOR. THE BINS WILL BE MANAGED BY THE BUILDING INTENDANT.

THE RECYCLING WILL BE PICKED UP ON EACH FLOOR, ONCE A WEEK BY THE BUILDING INTENDANT, OR BROUGHT DOWN BY THE TENANT, TO THE WASTE COLLECTION ROOM LOCATED ON THE GROUND FLOOR. THE RECYCLING WILL THEN BE DEPOSITED IN THE APPROPRIATE RECYCLING BINS.

METHOD:
 TRASH AND RECYCABLE WOULD THEN BE TAKEN ON DAYS OF COLLECTION BY THE BUILDING INTENDANT TO THE STREET CURB (BORTHWICK AVENUE).

THE BUILDING INTENDANT WILL BRING THEM BACK, ON THE SAME DAY, TO THE WASTE COLLECTION ROOM.

SIZE OF ROOM: 3350MM X 3455MM
 NUMBER OF RECYCLING CAN : 5 BINS - 965 X 1800 (750L)
 NUMBER OF TRASH CAN : 8 (65L)

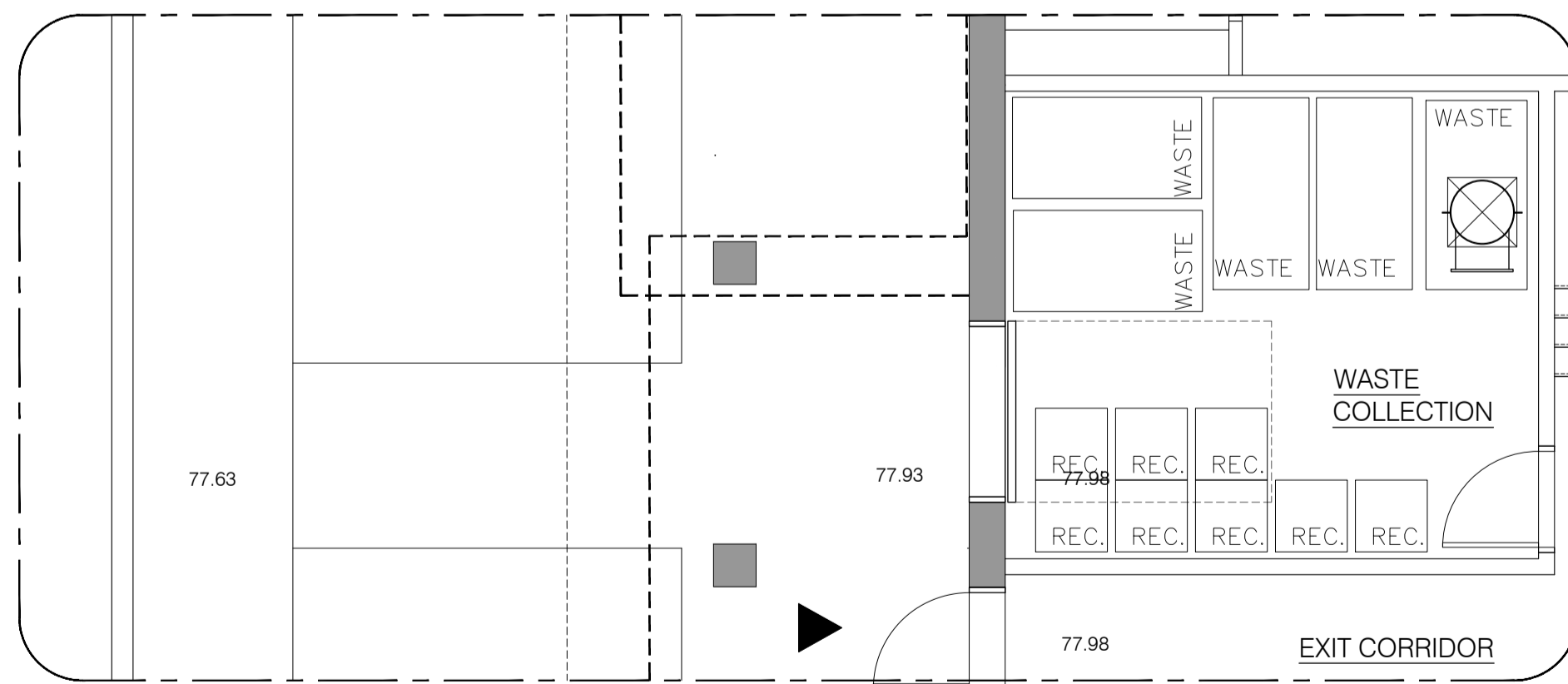

COMMERCIAL - WASTE AND RECYCLING COLLECTION

COMMERCIAL WASTE AND RECYCLING ARE COLLECTED BY EACH TENANT AND STORED IN A SPECIALLY DEDICATED ROOM ACCESSIBLE THROUGH THE BACK STORE.

METHOD:
 TRASH AND RECYCABLE ARE THEN COLLECTED IN 65 GALS CAN WITH WHEELS. THE UNIT WOULD THEN BE TAKEN ON DAYS OF COLLECTION TROUGH THE COURTYARD UP TO THE STREET (MONTREAL ROAD).

THEN THE PERSON IN CHARGE WILL BRING THEM BACK, ON THE SAME DAY, TO THE STORAGE AREA.

SIZE OF ROOM: 3350MM X 3455MM
 NUMBER OF RECYCLING CAN : 5
 NUMBER OF TRASH CAN : 5

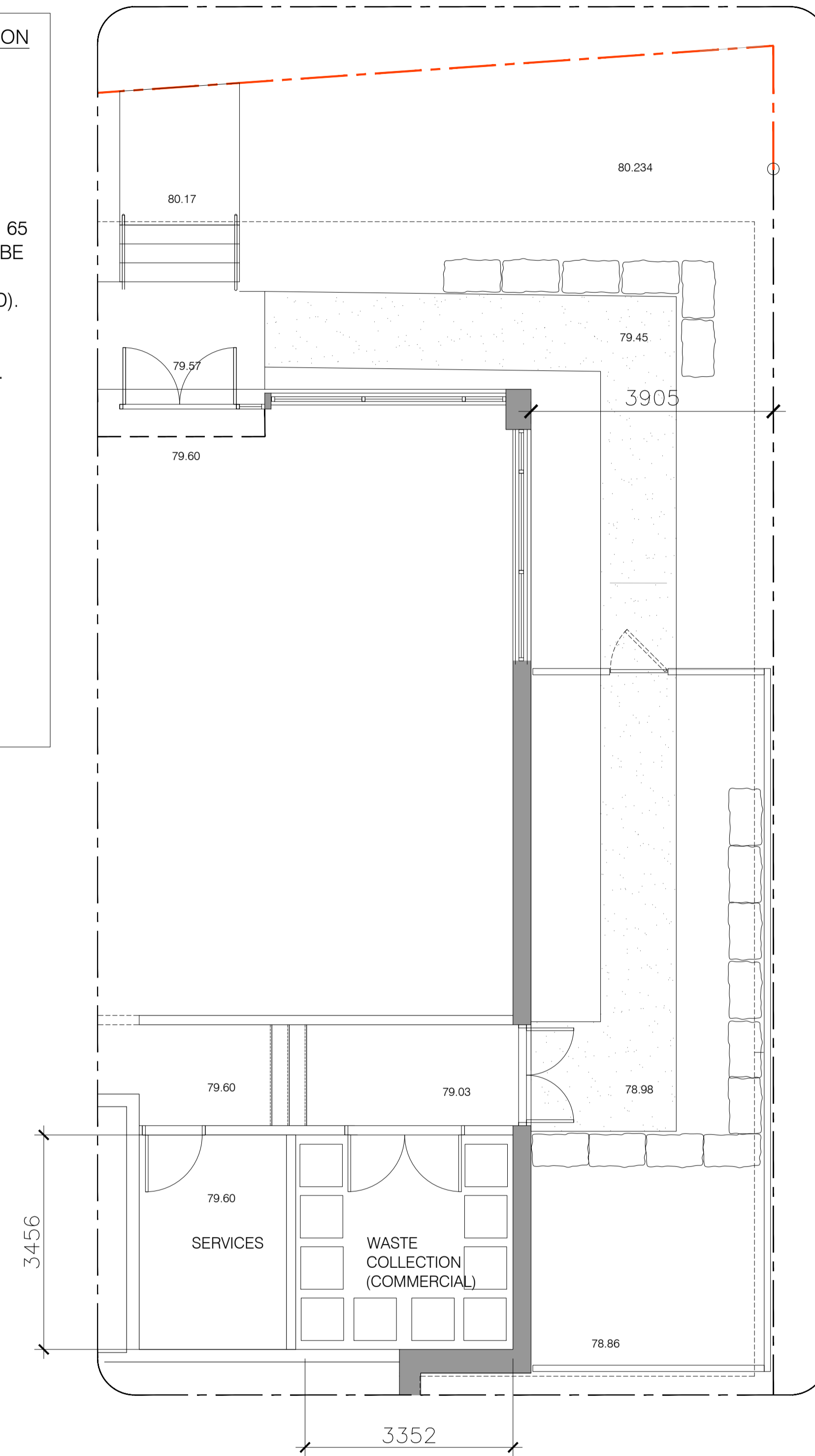



01 NORTH ELEVATION
1:100

MATERIAL LEGEND OF EXTERIOR FINISHES			
<p>1 MASONRY CLADDING / BRICK: BRICK: ENDICOTT BRICK SERIES: ARCHITECTURAL COLOR: SEE BELOW FORMAT: MODULAR DIMENSIONS: 194mmX92mmX57mm</p> <p>11</p>	<p>2 GLAZING TYPE 1 : CURTAIN WALL TYPE 2 : STANDARD FRAME : ALUMINIUM COLOR : BLACK GLASS : THERMOS CLEAR</p>	<p>3 PRECAST PANELS: COLOR: CONCRETE COLORS SAMPLE TO BE RECEIVED</p>	<p>4 SPANDREL PANEL CURTAIN WALL FRAME COLOR : BLACK GLASS : THERMOS CLEAR WITH OPAQUE BAKING</p>
<p>5 FLASHING AND FACIA OF THE PARAPET PREPAINTED STEEL TYPE : ALPOLIC OR EQUIVALENT COLOR: TO MATCH CONCRETE</p>	<p>6 CONCRETE BALCONY C/W CLEAR TEMPERED GLASS HANDRAIL AND PREPAINTED ALUMINIUM SUPPORTS. COLOR: BLACK</p>	<p>5a PREFINISH ALUMINIUM COLOR : BROWNISH TO MATCH BRICK</p>	<p>7</p>
<p>8 PREFINISH ALUMINIUM COLOR : BROWNISH TO MATCH BRICK</p>	<p>9 PREFINISH ALUMINIUM BRAND : DYZAL FINISH : WOOD GRAIN COLOR : JATOBA LIGHT GREY</p>		

NO DE DOSSIER: 2020-117

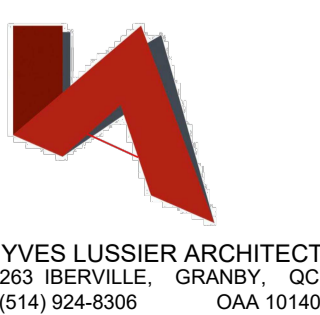

RACINE ■ OTTAWA ■
630 Montréal Road, Ottawa, On

LOT 45 AND PART OF LOTS 3, 4 & 5,
REGISTERED PLAN 343 (CITY OF OTTAWA)
. ACTUAL LAND AREA 970.77 M²*
*AFTER CITY ROAD WIDENING
. BUILDING FOOTPRINT (GFA): 502.55 M²
. NUMBER OF DWELLINGS: 56 UNITS

NORTH ELEVATION
A 13 | 18
REVISION 9 / 27-03 - 2024

007-12-21-0189
18965



MATERIAL LEGEND OF EXTERIOR FINISHES			
<p>1 MASONRY CLADDING / BRICK: BRICK: ENDICOTT BRICK SERIES: ARCHITECTURAL COLOR: SEE BELOW FORMAT: MODULAR DIMENSIONS: 194mmX92mmX57mm</p> <p>11 RED BLANK SMOOTH DESERT HONEYPOT</p>	<p>2 GLAZING TYPE 1: CURTAIN WALL TYPE 2: STANDARD FRAME: ALUMINIUM COLOR: BLACK GLASS: THERMOS CLEAR</p>	<p>3 PRECAST PANELS: COLOR: CONCRETE COLORS SAMPLE TO BE RECEIVED</p>	<p>4 SPANDREL PANEL CURTAIN WALL FRAME COLOR: BLACK GLASS: THERMOS CLEAR WITH OPAQUE BAKING</p>
<p>5 FLASHING AND FACIA OF THE PARAPET PREPAINTED STEEL TYPE: ALPOLIC OR EQUIVALENT COLOR: TO MATCH CONCRETE</p>	<p>6 CONCRETE BALCONY C/W CLEAR TEMPERED GLASS HANDRAIL AND PREPAINTED ALUMINIUM SUPPORTS COLOR: BLACK</p>	<p>5a PREFINISH ALUMINIUM COLOR: BROWNISH TO MATCH BRICK</p>	<p>9 PREFINISH ALUMINIUM BRAND: DYZAL FINISH: WOOD GRAIN COLOR: JATOBA LIGHT GREY</p>
<p>8 PREFINISH ALUMINIUM COLOR: BROWNISH TO MATCH BRICK</p>			

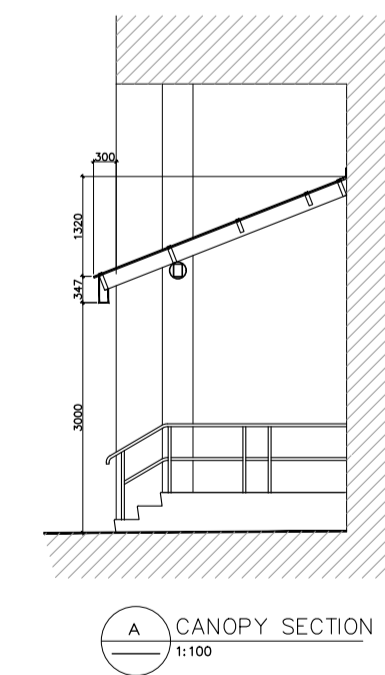

NO DE DOSSIER: 2020-117

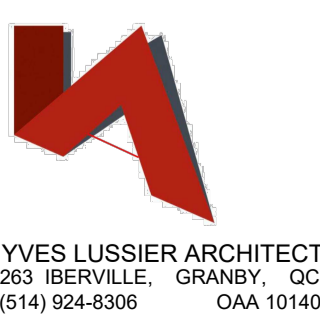







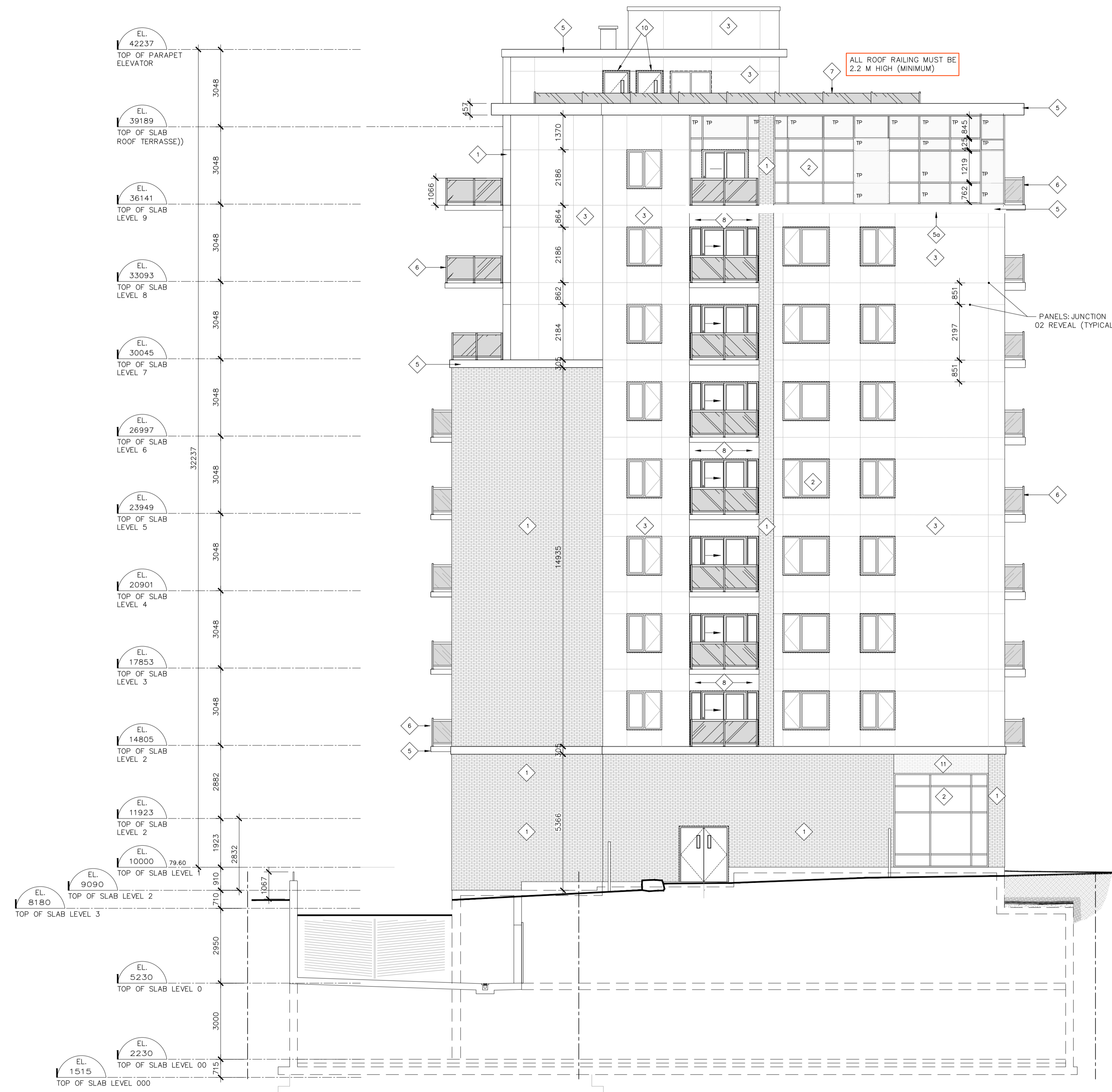

RACINE ■ OTTAWA ■
630 Montréal Road, Ottawa, On

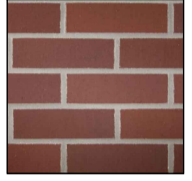
LOT 45 AND PART OF LOTS 3, 4 & 5,
REGISTERED PLAN 343 (CITY OF OTTAWA)
ACTUAL LAND AREA 970.77 M²*
*AFTER CITY ROAD WIDENING
BUILDING FOOTPRINT (GFA): 502.55 M²
NUMBER OF DWELLINGS: 56 UNITS

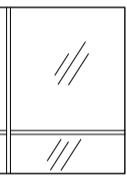
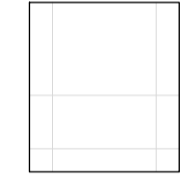
EAST ELEVATION
A 14 | 18
REVISION 9 / 27-03-2024

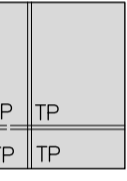
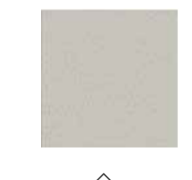
007-12-21-0189
18965

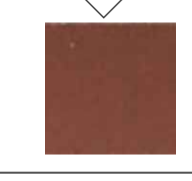







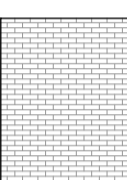
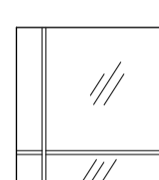

MATERIAL LEGEND OF EXTERIOR FINISHES				
<p>1 MASONRY CLADDING / BRICK: BRICK: ENDICOTT BRICK SERIES: ARCHITECTURAL COLOR: SEE BELOW FORMAT: MODULAR DIMENSIONS: 194mmX92mmX57mm</p>   <p>RED BLAND SMOOTH DESERT REDSPOT</p>	<p>2 GLAZING TYPE 1 : CURTAIN WALL TYPE 2 : STANDARD FRAME : ALUMINIUM COLOR : BLACK GLASS : THERMOS CLEAR</p> 			
<p>3 PRECAST PANELS: CURTAIN WALL COLOR: CONCRETE COLORS SAMPLE TO BE RECEIVED</p>  	<p>4 SPANDREL PANEL CURTAIN WALL FRAME COLOR: BLACK GLASS: THERMOS CLEAR WITH OPAQUE BAKING</p> 			
<p>5 FLASHING AND FACIA OF THE PARAPET PREPAINTED STEEL TYPE : ALPOLIC OR EQUIVALENT COLOR: TO MATCH CONCRETE</p> 	<p>6 CONCRETE BALCONY C/W CLEAR TEMPERED GLASS HANDRAIL AND PREPAINTED ALUMINIUM SUPPORTS COLOR: BLACK</p> 	<p>5a PREFINISH ALUMINIUM COLOR : BROWNISH TO MATCH BRICK</p> 		
<p>8 PREFINISH ALUMINIUM COLOR : BROWNISH TO MATCH BRICK</p> 	<p>9 PREFINISH ALUMINIUM BRAND : DYZAL FINISH : WOOD GRAIN COLOR : JATOBA LIGHT GREY</p> 			

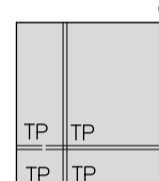
03 EAST ELEVATION
1 : 100



04 SOUTH ELEVATION
1:100

MATERIAL LEGEND OF EXTERIOR FINISHES			
<p>1 MASONRY CLADDING / BRICK: BRICK: ENDICOTT BRICK SERIES: ARCHITECTURAL COLOR: SEE BELOW FORMAT: MODULAR DIMENSIONS: 194mmx92mmx57mm</p>  <p>11</p>	<p>2 GLAZING TYPE 1 : CURTAIN WALL TYPE 2 : STANDARD FRAME : ALUMINIUM COLOR : BLACK GLASS : THERMOS CLEAR</p> 	<p>3 PRECAST PANELS: COLOR: CONCRETE COLORS SAMPLE TO BE RECEIVED</p> 	<p>4 SPANDREL PANEL CURTAIN WALL FRAME COLOR : BLACK GLASS : THERMOS CLEAR WITH OPAQUE BAKING</p> 
<p>5 FLASHING AND FASCIA OF THE PARAPET PREPAINTED STEEL TYPE : ALPOLIC OR EQUIVALENT COLOR : TO MATCH CONCRETE</p> 	<p>6 CONCRETE BALCONY C/W CLEAR TEMPERED GLASS HANDRAIL AND PREPAINTED ALUMINIUM SUPPORTS COLOR: BLACK</p> 	<p>5a PREFINISH ALUMINIUM COLOR : BROWNISH TO MATCH BRICK</p> 	<p>8 PREFINISH ALUMINIUM COLOR : BROWNISH TO MATCH BRICK</p> 
	<p>9 PREFINISH ALUMINIUM BRAND : DYZAL FINISH : WOOD GRAIN COLOR : JATOBA LIGHT GREY</p> 		

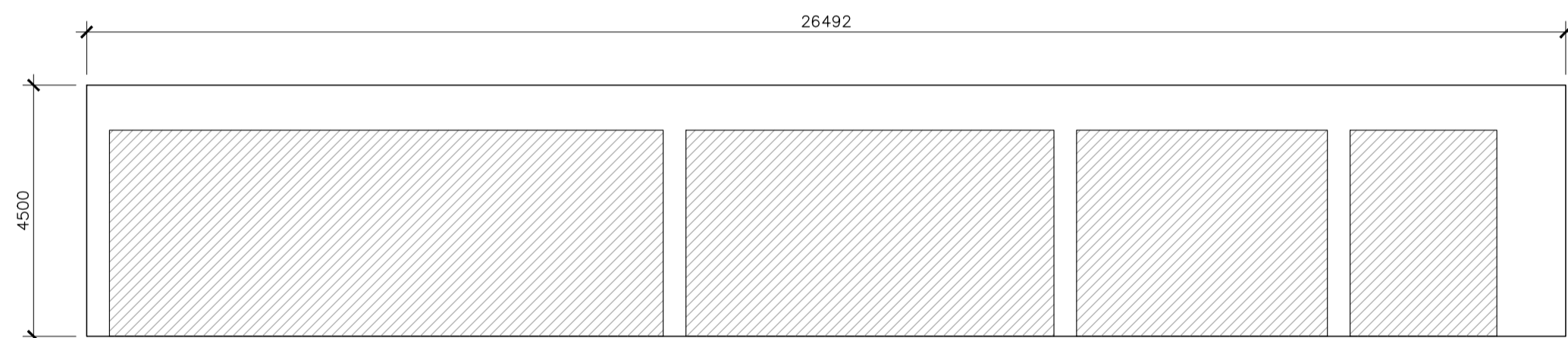

01 NORTH ELEVATION
NOT TO SCALE
TOTAL SURFACE 119.21 M²
TOTAL OPENING : 87.34 M²

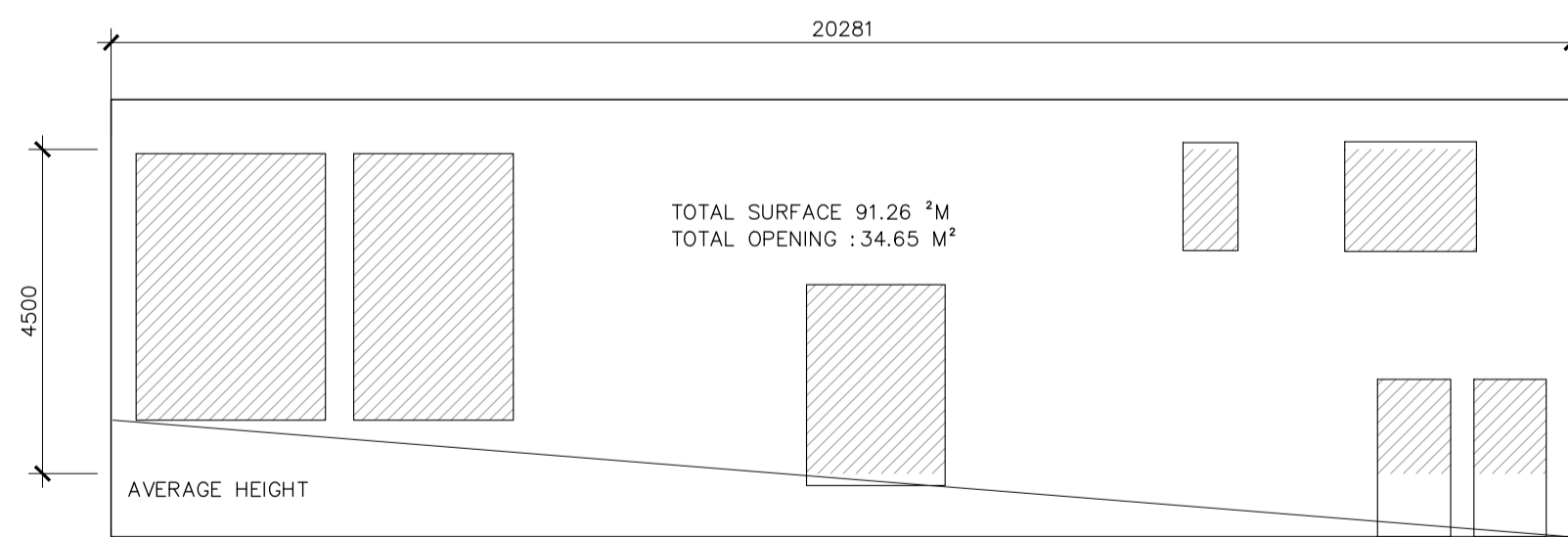

02 WEST ELEVATION
NOT TO SCALE
TOTAL SURFACE 91.26 M²
TOTAL OPENING : 34.65 M²

TOTAL AREA : 210.54 M²
TOTAL OPENING : 121.99 M²
PERCENTAGE GLAZED: 57.9%

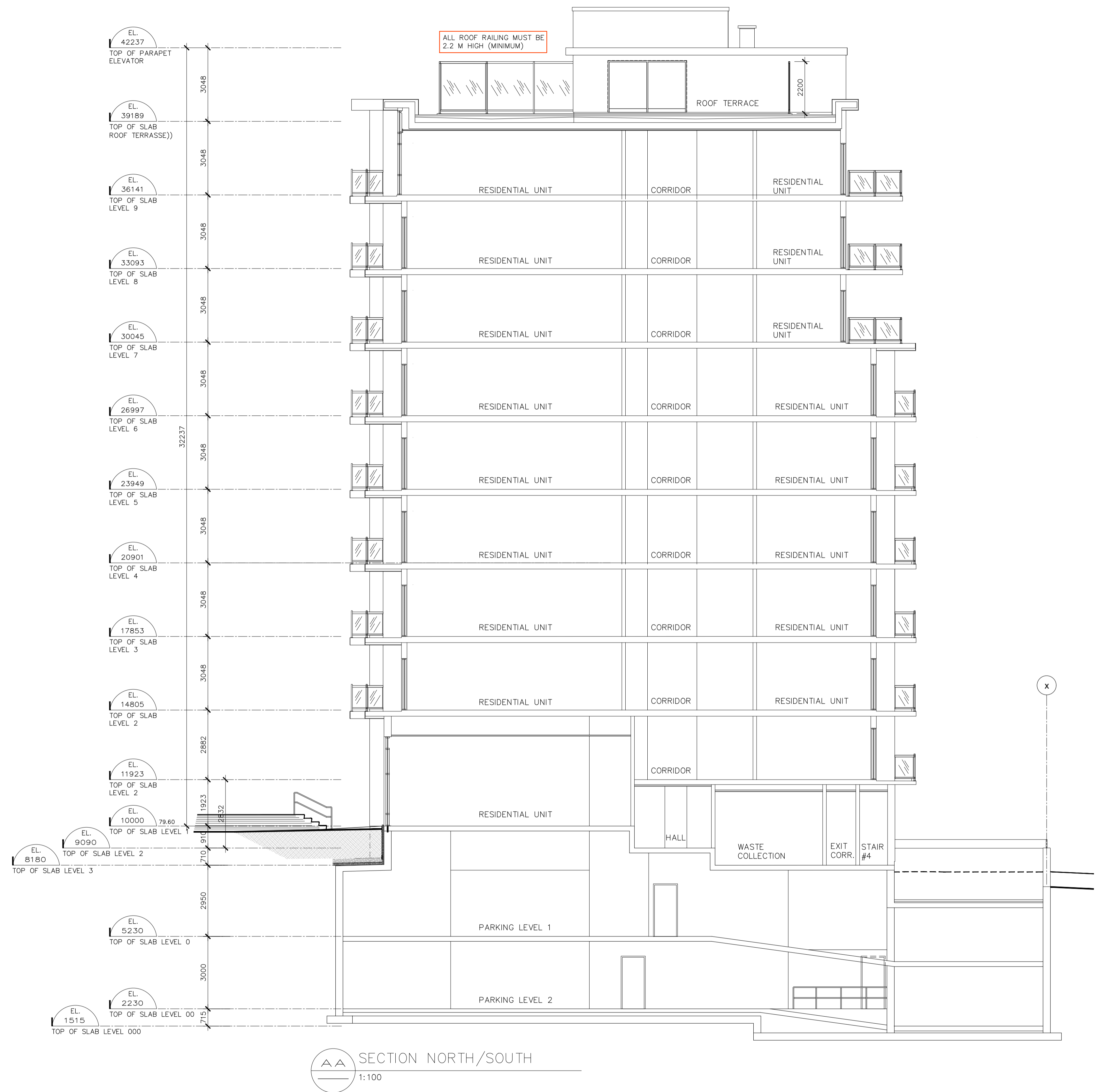

AA SECTION NORTH/SOUTH
1:100



03 EAST ELEVATION
NO SCALE



01 NORTH ELEVATION
NO SCALE



02 WEST ELEVATION
NO SCALE



04 SOUTH ELEVATION
NO SCALE

GLASS LEGEND FOR BIRD PROTECTION	
	WINDOW GLASS TO BE ETCHED PATTERN TO BE: 2 MM DIAMETER DOT PATTERN SPACED AT 50 MM C/C ON ALL DIRECTIONS. ALL ETCHING IS TO BE PERMANENT AND LOCATED ON THE EXTERIOR OF THE GLASS.
	RAILING HAVE A FROSTED PATTERN ON ALL SIDES. PATTERN TO BE: 2 MM DIAMETER DOT PATTERN SPACED AT 50 MM C/C ON ALL DIRECTIONS. ALL ETCHING IS TO BE PERMANENT AND LOCATED ON THE EXTERIOR OF THE GLASS.
	CURTAIN WALL WINDOWS TO BE ETCHED PATTERN TO BE: 2 MM DIAMETER DOT PATTERN SPACED AT 50 MM C/C ON ALL DIRECTIONS. ALL ETCHING IS TO BE PERMANENT AND LOCATED ON THE EXTERIOR OF THE GLASS.
	GLASS RAILING ON TERRASSE TO BE ETCHED PATTERN TO BE: 2 MM DIAMETER DOT PATTERN SPACED AT 50 MM C/C ON ALL DIRECTIONS. ALL ETCHING IS TO BE PERMANENT AND LOCATED ON THE EXTERIOR OF THE GLASS.
	NO HATCH ETCHED GLASS PATTERN ON THE PATIO DOOR AND SIDELIGHTS LOCATED IN THE BALCONY RECESS.

RACINE ■ OTTAWA ■
630 Montréal Road, Ottawa, On

LOT 45 AND PART OF LOTS 3, 4 & 5,
REGISTERED PLAN 343 (CITY OF OTTAWA)
ACTUAL LAND AREA 970.77 M²*
*AFTER CITY ROAD WIDENING
BUILDING FOOTPRINT (GFA): 502.55 M²
NUMBER OF DWELLINGS: 56 UNITS

SECTION NORTH/SOUTH
A 18 | 18
REVISION 9 / 27-03-2024