

NOT FOR CONSTRUCTION

TOPOGRAPHIC INFORMATION
 TOPOGRAPHIC INFORMATION PROVIDED BY STANTEC GEOMATICS LTD
 PROJ. NO. 1616149-110
 DATED DECEMBER 16, 2019

SITE PLAN INFORMATION
 SITE PLAN PROVIDED BY HOBIN ARCHITECTURE
 PROJ. NO. 1936
 DATED AUGUST 27, 2021

GEOTECHNICAL STUDY
 GEOTECHNICAL RECOMMENDATIONS PROVIDED BY GHD
 PROJ. NO. 11206675 (1)
 DATED AUGUST 2020

SITE SERVICING AND STORMWATER MANAGEMENT STUDY
 SERVICING AND STORMWATER MANAGEMENT RECOMMENDATIONS PROVIDED BY DSEL
 PROJ. NO. 19-1159
 DATED APRIL 2021

BENCH MARK
 TOP OF SPINDLE OF FIRE HYDRANT LOCATED AT BRISEBOIS CRESCENT NORTHEAST OF SUBJECT PROPERTY
 ELEV=66.99

| No. | BY | YY.MM.DD | DESCRIPTION |
|-----|--------|----------|-------------------------------------|
| 5 | A.D.F. | 21.12.16 | REVISED PER MUNICIPAL COMMENTS |
| 4 | B.N.C. | 21.08.31 | REVISED SWM CHAMBERS / ROOF STORAGE |
| 3 | A.J.C. | 21.05.07 | REVISED RIP-RAP EXTENTS |
| 2 | B.N.C. | 21.04.14 | ISSUED FOR MUNICIPAL REVIEW |
| 1 | B.N.C. | 20.11.20 | ISSUED FOR MUNICIPAL REVIEW |

SUMMARY OF SITE STORMWATER RELEASE RATES

| DRAINAGE AREA | ICD LOCATION | 5-YEAR RELEASE RATE (L/s) | 5-YEAR REQUIRED STORAGE (m³) | 100-YEAR RELEASE RATE (L/s) | 100-YEAR REQUIRED STORAGE (m³) | AVAILABLE STORAGE (m³) |
|------------------------------|-----------------|---------------------------|------------------------------|-----------------------------|--------------------------------|------------------------|
| U1 | N/A | 8.4 | 0.0 | 17.9 | 0.0 | 0.0 |
| U2 | N/A | 5.9 | 0.0 | 12.6 | 0.0 | 0.0 |
| (A103,A105,A106,A107A,A107B) | CBMH102 (N.INV) | 63.3 | 25.9 | 76.1 | 133.2 | 154.0 |
| A202 (BLDG) | N/A | 25.9 | 109.2 | 35.3 | 237.6 | 357.2 |
| TOTAL | | 103.6 | 135.1 | 141.8 | 370.8 | 511.2 |

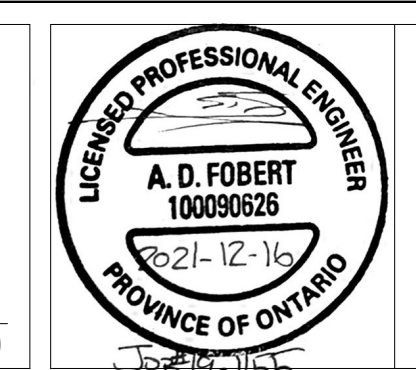
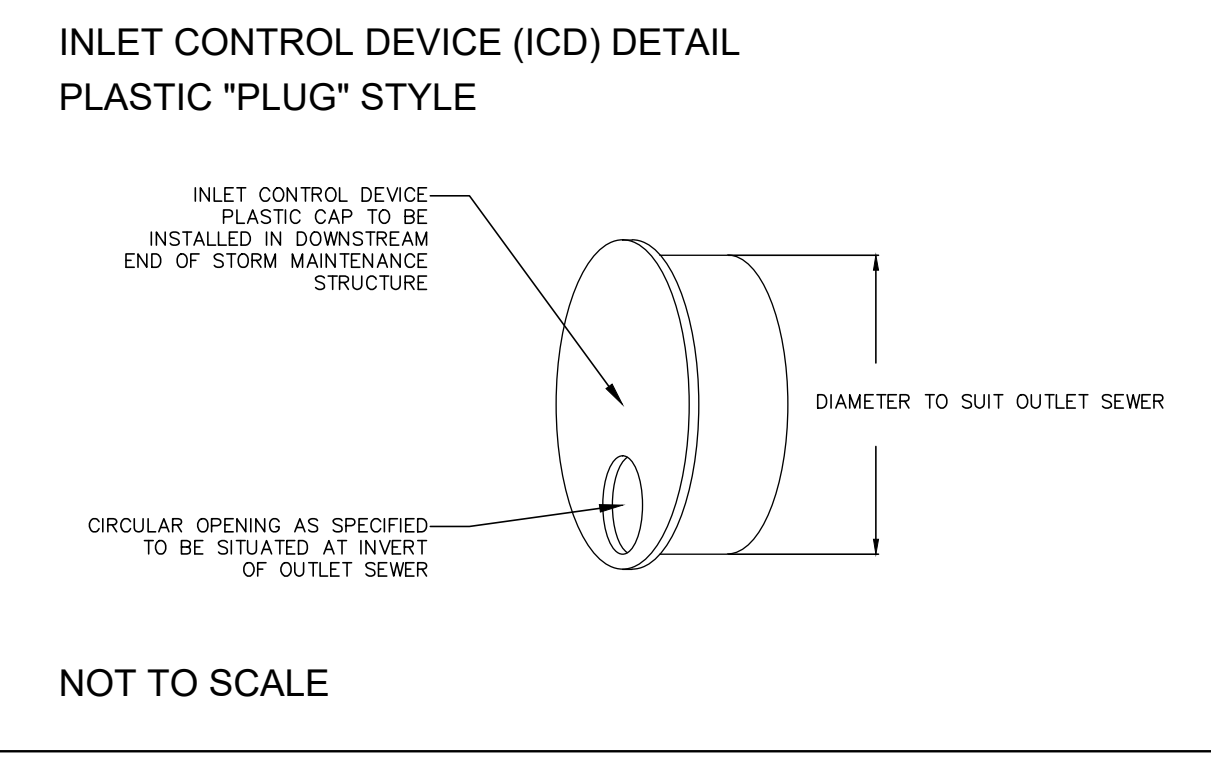

PROJECT No19-1159

STORMWATER MANAGEMENT PLAN
 211 CENTRUM BLVD © DSEL

LE GROUPE MAURICE
 24000, Rue Des Nations, Bureau 137
 Saint-Laurent, Quebec, H4R 3G4
 Tel. (514) 331-2788

DSEL
 david schaeffer engineering ltd
 SMART SUBSISTEMS™
 120 Iber Road Unit 103
 Stittsville, Ontario, K2S 1E9
 Tel. (613) 836-0856
 Fax. (613) 836-7183
 www.DSEL.ca

| | | | | | |
|--------------|--------|-------------|---------------|-------------|-----------|
| DRAWN BY: | B.N.C. | CHECKED BY: | A.D.F. | DRAWING NO. | SHEET NO. |
| DESIGNED BY: | B.N.C. | CHECKED BY: | A.D.F. | SWM-1 | 1 of 1 |
| SCALE: | 1:400 | DATE: | NOVEMBER 2020 | | |