

Engineering

Land/Site
Development

Municipal
Infrastructure

Environmental/
Water Resources

Traffic/
Transportation

Recreational

Planning

Land/Site
Development

Planning Application
Management

Municipal Planning

Urban Design

Expert Witness
(LPAT)

Wireless Industry

Landscape Architecture

Streetscapes &
Public Amenities

Open Space, Parks &
Recreation

Community &
Residential

Commercial &
Institutional

Environmental
Restoration



PROPOSED MULTI-TOWER DEVELOPMENT

314 & 318 Athlone Avenue and
2006, 2020 & 2026 Scott Street

Development Servicing Study and
Stormwater Management Report

**PROPOSED MULTI-TOWER DEVELOPMENT
314 & 318 Athlone Avenue, 2006, 2020 & 2026 Scott Street**

**DEVELOPMENT SERVICING STUDY
AND STORMWATER MANAGEMENT REPORT**

Prepared by:

NOVATECH

Suite 200, 240 Michael Cowpland Drive
Kanata, Ontario
K2M 1P6

February 22, 2023
Revised October 16, 2023
Revised March 5, 2024
Revised April 16, 2024
Revised June 28, 2024
Revised September 4, 2024
Revised February 4, 2026

Ref: R-2023-003
Novatech File No. 121302

February 4, 2026

Hoppner Holdings Inc.
1818 Bradley Side Road,
Carp, Ontario
K0A 1L0

Attention: Ken Hoppner

**Re: Development Servicing Study & Stormwater Management Report
Proposed Multi-Tower Development
314 & 318 Athlone Avenue and 2006, 2020 & 2026 Scott Street, Ottawa, ON
Novatech File No.: 121302**

Enclosed is a copy of the revised 'Development Servicing Study & Stormwater Management Report' for the proposed multi-tower residential development located at 314 & 318 Athlone Avenue, 2006, 2020 & 2026 Scott Street, in the City of Ottawa. This report addresses the approach to site servicing and stormwater management and is being submitted in support of Zoning By-Law Amendment (ZBLA) and Site Plan Control (SPC) applications.

Please contact the undersigned, should you have any questions or require additional information.

NOVATECH



François Thauvette, P. Eng.
Senior Project Manager

cc: Mohammed Fawzi (City of Ottawa)
John Wu (City of Ottawa)
Kelly Rhodenizer (Colonnade BridgePort)
Pat Bisson (Hobin)

TABLE OF CONTENTS

1.0	INTRODUCTION	1
1.1	Location and Site Description	1
1.2	Pre-Consultation Information	1
1.3	Proposed Development.....	2
1.4	Reference Material.....	2
2.0	SITE SERVICING.....	2
2.1	Sanitary Servicing	2
2.2	Water Supply for Domestic Use and Firefighting.....	4
2.2.1	<i>Water Demands and Watermain Analysis</i>	4
2.3	Storm Drainage and Stormwater Management.....	6
2.3.1	<i>Stormwater Management Criteria and Objectives</i>	7
2.3.2	<i>Pre-Development Conditions and Allowable Release Rate</i>	7
2.3.3	<i>Post-Development Conditions</i>	7
2.3.3.1	<i>Area A-1: Direct Runoff (North/East)</i>	8
2.3.3.2	<i>Area A-2 + OS-1: Uncontrolled Flow + Off-Site Tributary Area</i>	8
2.3.3.3	<i>Area A-3a: Controlled Site Flow (Building 1)</i>	8
2.3.3.4	<i>Area A-3b: Controlled Site Flow (Buildings 2 & 3).....</i>	9
2.3.3.5	<i>Area A-4: Direct Runoff (West/South).....</i>	9
2.3.3.6	<i>Stormwater Flow Summary</i>	9
2.3.4	<i>Stormwater Quality Control.....</i>	10
3.0	SITE GRADING	10
4.0	GEOTECHNICAL INVESTIGATIONS.....	11
5.0	EROSION AND SEDIMENT CONTROL	11
6.0	CONCLUSION	11

LIST OF FIGURES

Figure 1: Aerial View of the Subject Site

LIST OF APPENDICES

Appendix A: Project Correspondence

Appendix B: Development Servicing Study Checklist

Appendix C: Sanitary Sewage Calculations

Appendix D: Water Demands and FUS Calculations, Watermain Boundary Conditions, E-mail Correspondence from the City, Correspondence from Architect to support FUS calculations

Appendix E: IDF Curves and Preliminary SWM Calculations

Appendix F: City As-Built Drawings

Appendix G: Engineering Drawings

LIST OF PLANS

Existing Conditions and Removals Plan (121302-REM)

General Plan of Services (121302-GP)

Grading and Erosion and Sediment Control Plan (121302-GR)

Pre-Development Storm Drainage Area Plan (121302-SWM1)

Post-Development Storm Drainage Area Plan (121302-SWM2)

1.0 INTRODUCTION

Novatech has been retained by Hoppner Holdings Inc. to complete the site servicing, grading, and stormwater management design related to the proposed re-development of the properties at 314, 318 Athlone Avenue and 2006, 2020, 2026 Scott Street. This report is being submitted in support of Zoning By-Law Amendment (ZBLA) and Site Plan Control (SPC) applications.

1.1 Location and Site Description

The 0.659-hectare site currently consists of five (5) properties that will be merged, including the Granite Curling Club (2026 Scott Street), existing commercial properties (2006 and 2020 Scott Street) as well as two residential properties to the east (314 and 318 Athlone Avenue). The subject site is located on the south side of Scott Street, west of Athlone Avenue, and is bordered by other residential and commercial developments. The Ottawa Gymnastics Centre and Lion's Park abut the subject site to the south. The legal description of the site is designated as Part of Lot 60 and all of Lots 61 & 62 on Registered Plan 263, and Part of Lot 31, Concession 1 (Ottawa Front), (Geographic Township of Nepean), City of Ottawa.

Figure 1: Aerial View of the Subject Site



Image Source: geoOttawa (City of Ottawa)

1.2 Pre-Consultation Information

An initial pre-consultation meeting was held with the City of Ottawa on December 21, 2021, at which time the client was advised of the general submission requirements. The project was previously designed, approved by the City of Ottawa, subsequently put on hold but re-started as a new 3-tower development, requiring an updated pre-consultation meeting, which was held on October 2, 2025. The Rideau Valley Conservation Authority (RVCA) was also consulted regarding the proposed development. Based on a review of **O. Reg. 525/98: Approval Exemptions**, a Ministry of the Environment, Conservation and Parks (MECP) Environmental Compliance

Approval (ECA) will not be required for the proposed development. Refer to **Appendix A** for a summary of the correspondence related to the proposed development.

1.3 Proposed Development

The proposed development will be phased, consisting of three (3) towers of varying height with respective podiums, containing residential apartments located above at-grade commercial units. The site entrance off Athlone Avenue will provide access to Building 1 and the associated underground parking garage, while the site entrance off Scott Street will provide access to Buildings 2 and 3, the underground parking garage, and serve as the proposed fire access route for these towers. The remainder of the site will consist of a pedestrian courtyard and outdoor amenity space.

1.4 Reference Material

The following design guidelines have been used to establish the servicing and stormwater management requirements for the proposed development:

- Ottawa Sewer Design Guidelines (2025)
- Ottawa Water Distribution Design Guidelines (2025)
- Ministry of the Environment Design Guidelines for Sewage Works (2008)
- Ministry of the Environment Stormwater Management Planning and Design Manual (2003)
- Ministry of the Environment Design Guidelines for Drinking Water Systems (2008)
- Fire Underwriters Survey (FUS) Water Supply for Public Fire protection (2020)

The following reports and studies were prepared and/or reviewed as part of the design process:

- ¹ Assessment of Adequacy of Public Services Report (Ref. No. R-2022-163), prepared by Novatech, dated September 14, 2022.
- ² The Geotechnical Investigation Report (Ref. No. PG5829-1), prepared by Paterson Group Inc. on June 7, 2021.

2.0 SITE SERVICING

The objective of this report is to demonstrate that proper sewage outlets (sanitary and storm) as well as a suitable domestic water supply and appropriate fire protection are available for the proposed development. The servicing criteria, the expected sewage flows, and water demands are to conform to the requirements of the City of Ottawa municipal design guidelines for sewer and water distribution systems. Refer to the enclosed **General Plan of Services** (121302-GP) and to the subsequent sections of the report for further details.

The City of Ottawa Servicing Study Guidelines for Development Applications requires that a Development Servicing Study Checklist be included to confirm that each applicable item is deemed complete and ready for review by City of Ottawa Infrastructure Approvals. A completed checklist is enclosed in **Appendix B** of the report.

2.1 Sanitary Servicing

The existing buildings on site are currently being serviced by the 300mm dia. and 375mm dia. sanitary sewers in Athlone Avenue and Scott Street; however, based on a review of the as-built plan and profile provided by the City of Ottawa (15350p&p19_Scott), it appears the existing sanitary sewer along the western frontage of the site is in fact a 450mm dia. concrete pipe as

opposed to a 375mm dia. PVC pipe (as shown on geoOttawa). The local sanitary sewer flows north along Athlone Avenue, then west along Scott Street and discharges into the 1500mm dia. West Nepean Collector sewer, directly north of the subject site on the north side of Scott Street.

Under post-development conditions, the proposed development will continue to be serviced by the local municipal sanitary sewers in Scott Street. Due to internal mechanical constraints and to accommodate the anticipated construction phasing, Building 1 will be equipped with its own service lateral, which will connect to the 375mm dia. sanitary sewer in Scott Street. Buildings 2 and 3 will be serviced by a shared service lateral, which will connect to the 450mm sanitary sewer in Scott Street, further to the west.

The City of Ottawa design criteria were used to calculate the theoretical sanitary flows for the proposed development. The following design criteria were taken from the City of Ottawa Sewer Design Guidelines:

- Residential Units (1-Bedroom or Studio): 1.4 people per unit
- Residential Units (2-Bedroom): 2.1 people per unit
- Residential Units (3-Bedroom): 3.1 people per unit
- Average Daily Residential Sewage Flow: 280 L/person/day
- Residential Peaking Factors = 3.34 to 3.46 (Harmon Equation)
- Average Commercial Sewage Flow: 2.8 L/m²/day
- Commercial Peaking Factor (<20% Commercial Contribution) = 1.0
- Infiltration Allowance: 0.33 L/s/ha

Table 1 identifies the theoretical sanitary flows for the proposed development based on the above design criteria and information provided by the architect.

Table 1: Theoretical Post-Development Sanitary Flows

Proposed Development	Unit Count	Design Population	Res. Peak Flow (L/s)	Comm. Peak Flow (L/s)	Infiltration Allowance (L/s)	Total Peak Flow (L/s)
Building 1	285	462	5.08	0.01	0.07	5.16
Subtotal – Building 1 Outlet						5.16
Building 2	378	609	6.60	-	0.08	6.68
Building 3	194	313	3.51	-	0.06	3.57
Subtotal – Building 2 Outlet						10.25
Total	857	1,384	15.19*	0.01*	0.21*	15.41*

*Represents rounded values

The proposed 200mm dia. PVC sanitary service lateral for Building 1 at a minimum slope of 1.0% has a minimum full flow capacity of 34.2 L/s, while the proposed 250mm dia. PVC shared sanitary service lateral for Buildings 2 and 3, at a minimum slope of 1.0%, has a minimum full flow capacity of 62.0 L/s. Both service laterals should therefore have enough capacity to convey the respective theoretical sanitary flows from the proposed towers. Based on the internal plumbing configuration and OBC requirements determined by the mechanical consultant, the sanitary laterals may need to increase in size, which will consequently increase their conveyance capacity. Refer to **Appendix C** for detailed sanitary sewage calculations. Sanitary site flows will travel less than 50m

within the local municipal sanitary sewers in Scott Street before being discharged into the 1500mm dia. West Nepean Collector on the north side of Scott Street.

2.2 Water Supply for Domestic Use and Firefighting

The subject site is located within the City of Ottawa 1W pressure zone. The existing buildings on site are currently being serviced by a 200mm dia. PVC watermain on the south side of Scott Street and a 150mm UCI watermain in Athlone Avenue. A 1220mm dia. backbone watermain is also running along the north side of Scott Street, however the proposed development will not be allowed to connect to this large diameter backbone watermain.

Under post-development conditions, the proposed development will continue to be serviced by the 200mm dia. local municipal watermain in Scott Street. To accommodate the anticipated construction phasing, Building 1 will be serviced by extending twin service laterals to the municipal watermain. Buildings 2 and 3 will either be serviced by extending internal plumbing from Building 1 or by a shared twin water laterals to the municipal watermain, located further to the west along Scott Street. The anticipated daily water demands for each tower within the site will be greater than 50m³/day (~0.58 L/s), therefore, the proposed development will require a minimum of two (2) water supplies for redundancy purposes. The proposed towers will be sprinklered and the water meter(s) will be located within the water entry room(s), with the remote meter(s) and siamese connection(s) on the exterior face of the towers. The exact configuration and alignment of the Buildings 2 and 3 water service laterals will be confirmed through the detailed design of Phases 2 & 3 and provided as part of a future SPC submission.

2.2.1 Water Demands and Watermain Analysis

The theoretical water demand and fire flow calculations are based on criteria in the City of Ottawa Water Distribution Design Guidelines. The fire flow requirements were calculated per the Fire Underwriters Survey (FUS) as indicated in City of Ottawa Water Distribution Design Guidelines, based on information provided by the architect. The following design criteria were taken from the City of Ottawa Water Distribution Design Guidelines:

- Residential Units (1-Bedroom or Studio): 1.4 people per unit
- Residential Units (2-Bedroom): 2.1 people per unit
- Residential Units (3-Bedroom): 3.1 people per unit
- Average Daily Residential Water Demand: 280 L/person/day
- Maximum Day Demand Peaking Factor = 2.5 x Avg. Day Demand (City Water Table 4.2)
- Peak Hour Demand Peaking Factor = 2.2 x Max. Day Demand (City Water Table 4.2)
- Average Commercial Water Demand: 2.8 L/m²/day
- Maximum Day Demand Peaking Factor = 1.5 x Avg. Day Demand (City Water Table 4.2)
- Peak Hour Demand Peaking Factor = 1.8 x Max. Day Demand (City Water Table 4.2)

Table 2.1 identifies the theoretical domestic water demands and fire flow requirements for the development based on the above design criteria. Refer to **Appendix D** for detailed calculations.

Table 2.1: Theoretical Water Demand for Proposed Development

Proposed Development	Unit Count	Design Population	Avg. Daily Demand (L/s)*	Max. Daily Demand (L/s)*	Peak Hour Demand (L/s)*	FUS Fire Flow (L/s)
Building 1	285	462	1.5	3.8	8.3	150
Building 2	378	609	2.0	4.9	10.9	133
Building 3	194	313	1.0	2.5	5.6	150
Total	857	1,384	4.5	11.2	24.8	150 (Max)

*Represents rounded values, including commercial.

The following design criteria were taken from Section 4.2.2 – ‘Watermain Pressure and Demand Objectives’ of the City of Ottawa Design Guidelines for Water Distribution:

- Normal operating pressures are to range between 345 kPa (50 psi) and 483 kPa (70 psi) under Max Day demands.
- Minimum system pressures are to be 276 kPa (40 psi) under Peak Hour demands.
- Minimum system pressures are to be 140 kPa (20 psi) under Max Day + Fire Flow demands.

Preliminary domestic water demands, and fire flow requirements were provided to the City of Ottawa to generate the municipal watermain network boundary conditions assuming two (2) water supplies. **Table 2.2** summarizes the municipal watermain boundary conditions and the preliminary hydraulic analysis results based on the information provided by the City of Ottawa.

Table 2.2: Hydraulic Boundary Conditions Provided by the City (Existing Conditions)

Municipal Watermain Boundary Condition	Boundary Condition Head of Water (m)	Normal Operating Pressure Range (psi)	Anticipated WM Pressure (psi)*
2 x 200mm dia. Service Connections to the 200mm dia. WM in Scott Street			
Minimum HGL (Peak Hour Demand)	108.5 m	40 psi (min.)	~ 67 psi
Maximum HGL (Max Day Demand)	114.6 m	50-70 psi	~ 76 psi
HGL Max Day + Fire Flow (133 - 150 L/s)	104.9 m 103.7 m	20 psi (min.)	~ 62 psi ~ 61 psi

* Based on an approximate watermain elevation of 63.2m at the WM connection points in Scott Street. Design pressure = (HGL – watermain elevation) x 1.42197 PSI/m.

Based on preliminary calculations and correspondence received from the City of Ottawa, it is anticipated that the pressure within the municipal watermain network will be adequate and possibly exceed the upper end of the normal operating pressure range during the Max Day Conditions. Pressure reducing valves (PRV) may be required given the relatively high system

pressures. Given the height of the proposed buildings, booster pumps will be required to provide adequate water pressure to the upper floors.

As discussed with the City of Ottawa, a multi-hydrant approach to firefighting will be required to supply adequate fire flow to the proposed development. There are currently several Class AA (blue bonnet) hydrants within 150m of the proposed site. Based on the City of Ottawa Water Distribution Design Guidelines, Class AA (blue bonnet) hydrants within 75m have a maximum capacity of 95 L/s, while hydrants between 75m and 150m have a maximum capacity of 63 L/s (at a pressure of 20 PSI). **Table 2.3** summarizes the theoretical combined fire flow available from the nearby municipal fire hydrants and compares it to the fire flow demands based on the FUS calculations.

Table 2.3: Theoretical Fire Protection Summary Table

Building	(FUS) Fire Flow Demand (L/s)	Fire Hydrant(s) within 75m (~ 95 L/s each)	Fire Hydrant(s) within 150m (~ 63 L/s each)	Theoretical Combined Available Fire Flow (L/s)
Building 1	150	3	3	>150
Building 2	133	1	3	>133
Building 3	150	1	2	>150

The combined maximum flow from the nearby municipal hydrants will exceed the Max Day + Fire Flow requirement of the proposed development. This multi-hydrant approach to firefighting is in accordance with the City of Ottawa Water Distribution Design Guidelines. Refer to **Appendix D** for detailed calculations, correspondence from the City of Ottawa, a fire hydrant sketch showing the existing fire hydrant locations and the dimensions confirming the appropriate site coverage.

2.3 Storm Drainage and Stormwater Management

Storm drainage from the existing properties is currently being directed towards the local storm sewers in Scott Street and Athlone Avenue. The local storm sewers discharge into the West Transit Way Storm Trunk Sewer and outlet into the Ottawa River (just west of Onigam Street) approximately 2.9 km downstream of the subject site.

Under post-development conditions, storm flows from most of the site (~0.604 ha.) will be controlled prior to being directed to the storm sewers in Scott Street. Due to internal mechanical constraints and to accommodate the anticipated construction phasing, Building 1 will be equipped with its own service lateral, whereas Buildings 2 and 3 will be serviced by a shared service lateral; both service laterals will connect to the 1200 mm dia. storm sewer in Scott Street. Due to existing elevations, storm drainage from a small low-lying portion of the site (~0.008 ha.) will be drained internally before being directed to the 750mm dia. storm sewer in Athlone Avenue. Stormwater runoff from the north, east, and west sides of the site (~0.048 ha.) will be directed to the adjacent Scott Street, Athlone Avenue, and Ashton Avenue municipal right-of-ways. As previously discussed with the City of Ottawa, the intent is to remove the existing 375mm dia. STM sewer running along the west property line. Leaving the pipe and creating an easement will only encumber the proposed development.

2.3.1 Stormwater Management Criteria and Objectives

The stormwater management (SWM) quantity control criteria have been provided during a pre-consultation meeting with the City of Ottawa, and the objectives are as follows:

- Provide a dual drainage system (i.e., minor, and major system flows).
- Control post-development storm flows, up to and including the 100-year design event, to the maximum allowable release rate calculated using the Rational Method, with a runoff coefficient equivalent to existing conditions, but in no case greater than $C=0.5$, a time of concentration no less than 10 minutes and a 2-year rainfall intensity. Although the pre-consultation notes state a 5-year rainfall intensity, the City of Ottawa confirmed that the 2-year rainfall intensity is applicable via comments received through the previous Site Plan Control Application for the site.
- Maintain existing drainage patterns and major overland flow paths as much as possible.
- Provide guidelines to ensure that site preparation and construction is in accordance with the current Best Management Practices for Erosion and Sediment Control.

The subject site is located within the jurisdiction of the Rideau Valley Conservation Authority (RVCA). Based on correspondence from the RVCA on-site stormwater quality control measures will not be required due to the nature of the development, the fact that parking will be underground and that the distance to the stormwater outlet is >2km downstream. Refer to **Appendix A** for correspondence from the City of Ottawa and RVCA.

2.3.2 Pre-Development Conditions and Allowable Release Rate

Although unknown, it is assumed that site flows are currently not being controlled prior to being released into the municipal storm sewer systems. As specified by the City of Ottawa, the maximum allowable release rate from the subject site is to be calculated using the Rational Method, with a runoff coefficient equivalent to existing conditions, but in no case greater than $C=0.5$, a time of concentration of 10 minutes and a 2-year rainfall intensity from City of Ottawa IDF curves. The maximum allowable release rate for the proposed development is calculated as follows:

$$\begin{aligned}
 T_c &= 10 \text{ min} & C &= 0.50 \\
 I_{2\text{yr}} &= 76.81 \text{ mm/hr} & A &= 0.659 \text{ ha} \\
 Q_{\text{allow}} &= 2.78 \text{ CIA} \\
 &= 2.78 (0.50) (76.81) (0.659) \\
 &= 70.4 \text{ L/s}
 \end{aligned}$$

Refer to the **Pre-Development Storm Drainage Area Plan** (121302-SWM1) and to **Appendix D** for detailed SWM calculations.

2.3.3 Post-Development Conditions

The post-development conditions will include both uncontrolled direct runoff and controlled site flows. The uncontrolled direct runoff and site flows include areas on the north, east and west sides of the site. These areas will either sheet drain uncontrolled towards the adjacent streets as there is no practical way to capture this drainage and/or be captured by a catch basin and directed to the municipal storm sewer uncontrolled. The flows from the tower roofs and outdoor amenity space (above the underground parking structures) will be sent directly to internal SWM storage

tanks (SWM Tanks 1 and 2) and controlled (pumped) prior to being discharged into the municipal storm sewers in Scott Street, via separate service laterals. Refer to the enclosed **Post-Development Storm Drainage Area Plan** (121302-SWM2) for sub-catchment areas and to **Appendix E** for detailed SWM calculations.

2.3.3.1 Area A-1: Direct Runoff (North/East)

The uncontrolled post-development flow from this sub-catchment area was calculated, using the Rational Method, to be approximately 6.5 L/s during the 2-year design event, 8.9 L/s during the 5-year design event, and 16.9 L/s during the 100-year design event. Refer to **Appendix E** for detailed SWM calculations.

2.3.3.2 Area A-2 + OS-1: Uncontrolled Flow + Off-Site Tributary Area

Due to existing elevations, storm drainage from these small low-lying drainage areas will be captured by a new catch basin located adjacent to the east property line. Uncontrolled flows from sub-catchments A-2 + OS-1 (contributing off-site residential drainage) will be directed to the 750mm dia. storm sewer in Athlone Avenue via internal plumbing and a new service lateral. This configuration will ensure that existing drainage patterns and major overland flow paths are generally maintained along the south and east sides of the subject site. The uncontrolled post-development flow from these combined sub-catchment areas was calculated using the Rational Method to be approximately 10.2 (0.4+9.8) L/s during the 2-year design event, 13.8 (0.5+13.3) L/s during the 5-year design event, and 27.4 (1.0+26.4) L/s during the 100-year design event. Refer to **Appendix E** for detailed SWM calculations.

2.3.3.3 Area A-3a: Controlled Site Flow (Building 1)

Stormwater runoff from this sub-catchment area will be captured by the Building 1 uncontrolled roof drains and Phase 1 deck drains and will be directed to an internal SWM storage tank (SWM Tank 1). Stormwater collected within the storage tank will be pumped up to the Building 1 storm service lateral and released into the existing 1200mm dia. storm sewer in Scott Street. A pump (designed by the mechanical consultant) is required to control flow from the tank to a maximum rate of 13.5 L/s (214 USGPM). A “stand-by” pump will be provided for emergency and/or maintenance purposes. An emergency power supply will also be provided. CBMH 1 will provide access to the SWM storage tank and act as the emergency overflow from the tank to the surface. The internal plumbing is to be pressure rated piping specified by the mechanical engineer. The storm service will be equipped with a backflow prevention device to protect the building from any potential sewer back-ups. **Table 3.1** summarizes the controlled post-development design flows and approximate storage volumes from area A-3a during the 2-year, 5-year, and 100-year design events.

Table 3.1: Internal Stormwater Storage Tank 1 and Pumped Flow

Design Event	Post-Development Conditions		
	Pumped Design Flow (L/s)	Volume Required (m ³)	Volume Provided (m ³)
2-Year	13.5 L/s	11.8 m ³	> 56 m ³
5-Year		20.2 m ³	
100-Year		55.9 m ³	

As indicated in **Table 3.1** above, the internal SWM storage tank (SWM Tank 1) will provide sufficient storage for the 100-year design event. Refer to **Appendix E** for detailed calculations.

2.3.3.4 Area A-3b: Controlled Site Flow (Buildings 2 & 3)

Stormwater runoff from this sub-catchment area will be captured by the Buildings 2 & 3 roofs and Phases 2 & 3 deck drains and will be directed to an internal SWM storage tank (SWM Tank 2). Stormwater collected within the storage tank will be pumped up to the storm service lateral and released into the existing 1200mm dia. storm sewer in Scott Street. A pump (designed by the mechanical consultant) is required to control flow from the tank to a maximum rate of 28.0 L/s (444 USGPM). A “stand-by” pump will be provided for emergency and/or maintenance purposes. An emergency power supply will also be provided. CBMH 2 will provide access to the SWM storage tank and act as the emergency overflow from the tank to the surface. The internal plumbing is to be pressure rated piping specified by the mechanical engineer. The storm service will be equipped with a backflow prevention device to protect the building from any potential sewer back-ups. **Table 3.2** summarizes the controlled post-development design flows and approximate storage volumes from area A-3b during the 2-year, 5-year, and 100-year design events.

Table 3.2: Internal Stormwater Storage Tank and Pumped Flow

Design Event	Post-Development Conditions		
	Pumped Design Flow (L/s)	Volume Required (m ³)	Volume Provided (m ³)
2-Year	28.0 L/s	32.6 m ³	> 142 m ³
5-Year		54.1 m ³	
100-Year		141.6 m ³	

As indicated in **Table 3.2** above, the internal SWM storage tank (SWM Tank 2) will provide sufficient storage for the 100-year design event. These capacity requirements are based on a fully impervious sub-catchment area (i.e., surface runoff coefficient = 0.9), as the landscape design has not been completed for Phases 2 and 3. The exact storage requirements will therefore need to be confirmed through the detailed design of Phases 2 and 3, which will be provided as part of a future Site Plan Control application. Refer to **Appendix E** for detailed calculations.

2.3.3.5 Area A-4: Direct Runoff (West/South)

The uncontrolled post-development flow from this sub-catchment area was calculated using the Rational Method to be approximately 2.3 L/s during the 2-year design event, 3.1 L/s during the 5-year design event, and 5.9 L/s during the 100-year design event. Refer to **Appendix E** for detailed SWM calculations.

2.3.3.6 Stormwater Flow Summary

Table 3.3 provides a summary of the total post-development flows from the site and compares them to the uncontrolled pre-development flows and to the respective allowable release rates specified by the City of Ottawa.

Table 3.2: Stormwater Flows Comparison Table

Design Event	Drainage Areas A-1, A-2, A-3a, A-3b, and A-4								
	Pre-Development Conditions		Post-Development Conditions						
	Uncontrolled Flow (L/s)	Allowable Release Rate (L/s)	A-1 Flow (L/s)	A-2 Flow (L/s)	A-3a Flow (L/s)	A-3b Flow (L/s)	A-4 Flow (L/s)	Total Flow (L/s)	Reduction in Flow (L/s or %) *
2-Yr	122.0	70.4	6.5	0.4	13.5	28.0	2.3	50.7	71.3 or 58%
5-Yr	165.6		8.9	0.5	13.5	28.0	3.1	54.0	111.6 or 67%
100-Yr	315.7		16.9	1.0	13.5	28.0	5.9	65.3	250.4 or 79%

*Reduced flow compared to pre-development uncontrolled conditions.

As indicated in the table above, the post-development flows from the site will not exceed the allowable release rate specified by the City of Ottawa. Furthermore, this represents significant reductions in total site flow rate when compared to the uncontrolled pre-development conditions. Most of the flows are being directed towards the storm sewer in Scott Street, however a small portion (A-2) is being directed to the municipal storm sewer in Athlone Avenue.

2.3.4 Stormwater Quality Control

The subject site is located within the jurisdiction of the Rideau Valley Conservation Authority (RVCA) and is tributary to the Ottawa River. Based on preliminary feedback from the RVCA, landscaped areas and roof tops are considered clean for the purpose of protecting water quality for aquatic habitat. In this case, since parking will be provided underground and the distance to the stormwater outlet is > 2 km downstream, on-site stormwater quality control will not be required. Refer to **Appendix A** for correspondence from the RVCA and City of Ottawa.

3.0 SITE GRADING

The existing site is relatively flat, and generally slopes in a northeastern direction. Along the front of the site, the northwest property corner elevation is approximately 63.28m and slopes to 62.51m at the northeastern property corner. Along the back of the site, the grade slopes in a southeasterly direction, the existing elevation at the southwestern corner of the property is approximately 62.79 and slopes to approximately 62.59m in the southeastern corner of the site. Under post-development conditions, the site will continue to slope from the back to the front. The proposed finished floor elevation (FFE) of the buildings will be between 63.65m – 63.75m to provide a barrier free access to the proposed buildings. The existing grades around the perimeter of the site will generally be maintained. A small retaining wall will be required along portions of the south and east property lines to protect the proposed buildings from the (existing) major overland flow route through the site. Refer to the enclosed **Grading and Erosion & Sediment Control Plan** (121302-GR) for details.

4.0 GEOTECHNICAL INVESTIGATIONS

A Geotechnical Investigation Report has been prepared by Paterson Group Inc. for the proposed project. Refer to the Geotechnical Report² for subsurface conditions, construction recommendations and geotechnical inspection requirements.

5.0 EROSION AND SEDIMENT CONTROL

To mitigate erosion and to prevent sediment from entering the storm drainage system, temporary erosion and sediment control measures will be implemented on-site during construction in accordance with Best Management Practices for Erosion and Sediment Control. Details are provided on the Grading and Erosion and Sediment Control Plan. This includes the following measures:

- Filter bags / catch basin inserts (sediment sacks) will be placed under the grates of nearby catch basins and manholes, and they will remain in place until vegetation has been established and construction is completed.
- Silt fencing will be placed per OPSS 577 and OPSD 219.110 along the surrounding construction limits.
- Mud mats will be installed at the site entrances.
- Street sweeping and cleaning will be performed, as required, to suppress dust and to provide safe and clean roadways adjacent to the construction site.
- On-site dewatering is to be directed to a sediment trap and/or gravel splash pad and discharged safely to an approved outlet as directed by the engineer.
- Any stockpiled material will be properly managed to prevent those materials from entering the sewer system and/or the downstream ditch or watercourse.

The temporary erosion and sediment control measures will be implemented prior to construction and will remain in place during all phases of construction. Regular inspection and maintenance of the erosion control measures will be undertaken.

6.0 CONCLUSION

This report has been prepared in support of ZBLA and SPC applications for the proposed development. The conclusions are as follows:

- The proposed development will be serviced by the municipal infrastructure in Scott Street and Athlone Avenue.
 - Sanitary flows from Building 1 will be directed to the existing 375mm dia. municipal sanitary sewer in Scott Street. Sanitary flows from Buildings 2 and 3 will be directed to the existing 450mm dia. municipal sanitary sewer in Scott Street.
 - The proposed development will continue to be serviced by the municipal watermain network via a minimum of two (2) water service laterals connecting to the existing 200mm watermain in Scott Street. Adequate water supply and system pressures will exist throughout the watermain network under the specified 'Max Day + Fire Flow' and 'Peak Hour' conditions.
 - Storm flows from the Building 1 roof and a portion of the Phase 1 site area (above the underground parking structure) will be sent to internal SWM Tank 1, then pumped out to the existing 1200mm dia. municipal storm sewer in Scott Street.

Similarly, storm flows from the Building 2 & 3 roofs and a portion of the Phase 2 & 3 site area (above the underground parking structure) will be sent to internal SWM Tank 2, then pumped out to the existing 1200mm dia. municipal storm sewer in Scott Street.

- Storm flows from the low-lying areas on the east side of the site, including tributary off-site flow from the adjacent residential properties will be directed to the existing 750mm dia. municipal storm sewer in Athlone Avenue, thus maintaining existing drainage patterns.
- The proposed building will be sprinklered and the municipal watermain network, including the nearby municipal fire hydrants will provide the necessary water for firefighting purposes.
- The total post-development flow directed to the municipal storm sewer systems in Scott Street, Athlone Avenue, and Ashton Avenue will be approximately 50.7 L/s during the 2-year design event, 54.0 L/s during the 5-year design event, and 65.3 L/s during the 100-year event, all less than the allowable release rate for the site (70.4 L/s) specified by the City of Ottawa.
- Regular inspection and maintenance of the building services, roof drains, internal SWM tanks and pumps is recommended to ensure that the storm drainage system is clean and operational.
- Erosion and sediment controls are to be provided during construction.

It is recommended that the proposed site servicing and stormwater management design be approved for implementation.

NOVATECH

Prepared by:



Kynan D'sa, B.A.Sc. (Engineering)
CAD Designer - Land Development

Reviewed by:



François Thauvette, P. Eng.
Senior Project Manager – Land Development

APPENDIX A
Project Correspondence

Re: 2026 Scott St.

Ward 15 - Kitchissippi, Councillor Jeff Leiper

30-Storey, 35-Storey and a 40-Storey high rise towers on a single podium, with 6 levels of UG Parking

Infrastructure:

A 203 mm dia. PVC Watermain (c. 1994) is available.

A 1220 mm dia. C00 Feeder High Pressure Watermain (c. 1959) is in ROW on North side of Scott Street. Monitoring of Feed WM is required when within 15m of proposed footing and foundation location.

A 375 mm dia. Clay. Sanitary Sewer (c. 1961) is available, which drains to West Nepean Trunk Collector and conveys effluent to the Interceptor Sewer.

A 900 mm dia. Conc. Storm Sewer (c. 1981) is available at western side of frontage to Scott St, which drains to West Transit Way Storm Trunk Sewer and Outlets to the Ottawa River at Onigam Street.

A 1200 mm dia. Conc. Storm Sewer (c. 1972) is available at eastern side of frontage to Scott St., which drains to West Transit Way Storm Trunk Sewer and Outlets to the Ottawa River at Onigam Street.

The following apply to this site and any development within a separated sewer area:

- Total allowable release rate will be 5-year pre-development rate.
- Coefficient (C) of runoff will need to be determined **as per existing conditions** but in no case more than 0.5
- TC = 20 minutes or can be calculated
TC should be not be less than 10 minutes, since IDF curves become unrealistic at less than 10 min.
- Any storm events greater than 5 year, up to 100 year, and including 100-year storm event must be detained on site.
- Two separate sewer laterals (one for sanitary and other for storm) will be required.

Please note:

Foundation drains are to be independently connected to sewermain (separated or combined) unless being pumped with appropriate back up power, sufficient sized pump and back flow prevention.

Roof drains are to be connected downstream of any incorporated ICD within the SWM system. Provide Roof plan showing roof drain and scupper locations with a table that indicates flow rates, drain type and weir opening, if controlled. Provide Manufacturer Specifications on drains and also provide 5- and 100-year ponding limits on plan.

Boundary Conditions will be provided at request of consultant after providing Average Daily Demands, Peak Hour Demands & Max Day + Fire Flow Demands

If window wells are proposed, they are to be indirectly connected to the footing drains. A detail of window well with indirect connection is required, as is a note at window well location speaking to indirect connection.

Please note:

We have reached out to our colleagues in the City Water Resource Department for any additional comments regarding this proposal in regard to capacity, historical flooding issues etc.

Note:

If applicable, existing buildings require a CCTV inspection and report to ensure existing services to be re-used are in good working order and meet current minimum size requirements. Located services to be placed on site servicing plans.



CCTV Scan
Guideline.pdf

Other:

Environmental Noise Study is required due to Scott Street and Transit Way.

Stationary Noise Study – consultant to speak to this in their report as per City NCG and NPC 300 Guidelines. May be required after Mechanical Design completed and prior to building permit issuance.

When greater than 9 Storeys in height, a Shadow Study required for all buildings/dwellings.

When greater than 9 Storeys in height Wind Study for all buildings/dwellings.

Water Supply Redundancy – Fire Flow:

Applicant to ensure that a second service with an inline valve chamber be provided where the average daily demand exceeds 50 m³ / day (0.5787 l/s per day)

FUS Fire Flow Criteria to be used unless a low-rise building, where OBC requirements may be applicable.



W12.pdf

Site Lighting:

Site lighting certificate and photometric plan required for this site. This will be a condition of agreement(s).

Site lighting certificate and photometric plan required for this site, particularly looking at light spillage and effects on nearby residential properties.

Capital Works:

Temporary Emergency Construction Restriction Process in effect on Scott Street – until April 2022 - for Cleary Watermain Work.

LRT Construction in effect

Trees:

Please note that a new Tree By-law is now in effect.



General Bulletin_New
Tree Protection Bylaw.

A gas pressure regulating station may be required depending on HVAC needs (typically for 12+ units). Be sure to include this on the Grading, Site Servicing, SWM and Landscape plans. This is to ensure that there are no barriers for overland flow routes (SWM) or conflicts with any proposed grading or landscape features with installed structures and has nothing to do with supply and demand of any product.



Gas Pressure
Regulating Station.pdf

Regarding Quantity Estimates:

Please note that external Garbage and/or bicycle storage structures are to be added to QE under Landscaping as it is subject to securities.

In addition, sump pumps for Sanitary and Storm laterals and/or cisterns are to be added to QE under Hard items as it is subject to securities, even though it is internal and is spoken to under SWM and Site Servicing Report and Plan.

Source Protection Policy Screening (SPPS):

SPPS will be provided to applicant by City Risk Mgmt. Officer within Asset Mgmt. Dept.

Applicant to contact Rideau Valley Conservation Authority (RVCA) for possible restrictions due to quality control. Provide correspondence in Report.

Where servicing involves three or more service trenches, either a full road width or full lane width 40 mm asphalt overlay will be required, as per amended Road Activity By-Law 2003-445 and City Standard Detail Drawing R10. The amount of overlay will depend on condition of roadway and width of roadway(s).

Vibration monitoring will be required for all backbone watermains within 15m proximity of footings/foundation for this site. Conditions for Vibration will be applied to agreements. For example:

Vibration Monitoring

Prior to the issuance of a building permit, the Owner shall, at its expense:

- (i) provide the General Manager, Planning, Infrastructure and Economic Development with an engineering memorandum from a Professional Engineer, licensed in the Province of Ontario, which shall outline the centreline location and overt elevation of the existing 1.220mm diameter C00 City owned Feeder Watermain (FWM), located on the north side of Scott Street, and its measured proximity to the frontage property boundary limits of 2026 Scott Street in order to evaluate the impact on said FWM from the proposed building's footing and foundation walls proposed for this development.
- (ii) obtain a legal survey acceptable to the General Manager, Planning, Infrastructure and Economic Development and the City's Surveyor, showing the existing location of the 1.220mm diameter C00 FWM within Scott Street Right-of-Way ("ROW") between Winona and Athlone Avenues and identify the location of the proposed building and its footings in relation the said FWM;

- (iii) provide the General Manager, Planning, Infrastructure and Economic Development with a Vibration Monitoring Plan from a Professional Engineer, specializing in vibration and monitoring, licensed in the Province of Ontario, which shall outline applicable recommendations for continuous monitoring of the existing 1220 mm dia. C00 FWM during all stages of the Work, including, but not limited to, the boundary area in the ROW between East side of Winona Avenue intersection and the West side of Athlone Avenue intersection. This monitoring will also provide a Work Plan speaking to Work in Vicinity of Large Diameter WM & Monitoring for site development as well as an extensive Emergency Contingency Plan, to be pre-approved by City Infrastructure Services Department (ISD).
- (iv) provide, during the construction process and upon completion of construction on the private & City lands, at the Owner's expense and to the satisfaction of the General Manager, Planning, Infrastructure and Economic Development, all daily and hourly data reports (as applicable) of completed monitoring works
- (v) assume all liability for any damages caused to the City Water & Sewer Systems within Scott Street ROW between Winona and Athlone Avenues and compensate the City for the full amount of any required repairs to the City Water & Sewer Systems.

Note: In addition to requirement of a vibration specialist engineer required to design and monitor vibration, a certificate of liability insurance shall be submitted to the City wherein the Owner is the named insured and the City of Ottawa is an additional insured. The limits of the policy shall be in the amount of \$25,000,000 and shall be kept in full force and effect for the term of the construction work.

Excavation:

Pre-Construction (Piling/Hoe Ramming or close proximity to City Assets) and/or Pre-Blasting (if applicable) Survey required for any buildings/dwellings in proximity of 75m of site and circulation of notice of vibration/noise to residents within 150 m of site. Conditions for Pre-Construction/ Pre-Blast Survey & Use of Explosives will be applied to agreements. Refer to City's Standard S.P. No. F-1201 entitled *Use of Explosives*, as amended.

Proximity to Transit Way:

Due to proximity of site to Transit Way and Westboro Transit Station, applicant to contact City LRT Group in regard to required building offset from transitway. Noise study to review vibration conditions within 75m of Transitway. See Rail Guidelines and CPCS Report as well as OP Annex 17, Zones of Influence and Guidelines for Proximity Study.



Where underground storage (UG) and surface ponding are being considered:

Show all ponding for 5- and 100-year events

Above and below ground storage is permitted although uses $\frac{1}{2}$ Peak Flow Rate or is modeled. Please confirm that this has been accounted for and/or revise.

Rationale:

The Modified Rational Method for storage computation in the Sewer Design Guidelines was originally intended to be used for above ground storage (i.e. parking lot) where the change in head over the orifice varied from 1.5 m to 1.2 m (assuming a 1.2 m deep CB and a max ponding depth of 0.3 m). This change in head was small and hence the release rate fluctuated little, therefore there was no need to use an average release rate.

When underground storage is used, the release rate fluctuates from a maximum peak flow based on maximum head down to a release rate of zero. This difference is large and has a significant impact on storage requirements. We therefore require that an average release rate be used to estimate the required volume. Alternatively, the consultant may choose to use a submersible pump in the design to ensure a constant release rate.

In the event that there is a disagreement from the designer regarding the required storage, The City will require that the designer demonstrate their rationale utilizing dynamic modelling, that will then be reviewed by City modellers in the Water Resources Group.

Note that the above will added to upcoming revised Sewer Design Guidelines to account for underground storage, which is now widely used.

Further to above, what will be the actual underground storage provided during the major (100 year) and minor (2 year) storm events?

Please provide information on UG storage pipe. Provide required cover over pipe and details, chart of storage values, capacity etc. How will this pipe be cleaned of sediment and debris?

Note - There must be at least 15cm of vertical clearance between the spill elevation and the ground elevation at the building envelope that is in proximity of the flow route or ponding area. The exception in this case would be at reverse sloped loading dock locations. At these locations, a minimum of 15cm of vertical clearance must be provided below loading dock openings. Ensure to provide discussion in report and ensure grading plan matches if applicable.

Provide information on type of underground storage system including product name and model, number of chambers, chamber configuration, confirm invert of chamber system, top of chamber system, required cover over system and details, interior bottom slope (for self-cleansing), chart of storage values, length, width and height, capacity, entry ports (maintenance) etc.

Provide a cross section of underground chamber system showing invert and obvert/top, major and minor HWLs, top of ground, system volume provided during major and minor events. UG storage to provide actual 2- and 100-year event storage requirements.

In regard to all proposed UG storage, ground water levels (and in particular HGW levels) will need to be reviewed to ensure that the proposed system does not become surcharged and thereby ineffective.

Modeling can be provided to ensure capacity for both storm and sanitary sewers for the proposed development by City's Water Distribution Dept. – Modeling Group, through PM and upon request.

For proposed depressed driveways or developments with private lanes, parking areas or with entrances etc. lower than roadway...



S18.pdf



S18.1.pdf

Rear yard on grade parking to be permeable pavement. Refer to City Standard Detail Drawings SC26 (maintenance/temp parking areas), SC27 or permeable asphalt materials. No gravel or stone dust parking areas permitted.

Severance:

If severance is planned, this needs to be addressed in servicing to satisfy severance requirements. Where a large parcel with multiple buildings is planned, City will require an ultimate servicing plan so as to appropriately understand how severance requirements are being met.

Note:

“Provided Info to applicant”:

Please be advised that it is the responsibility of the applicant and their representatives/consultants to verify information provided by the City of Ottawa. Please contact City View and Release Info Centre at Ext. 44455

Environmental Source Information:

Due to more sensitive use, a Record of Site Condition (RSC) is required. Ensure Phase I, and if applicable, Phase II ESA's speak to required RSC.

City of Ottawa - Historical Land Use Inventory (HLUI) - Required

Rationale:

The HLUI database is currently undergoing an update. The updated HLUI will include additional sources beyond those included in the current database, making the inclusion of this record search even more important.

Although a municipal historic land use database is not specifically listed as required environmental record in O. Reg 153/04, Schedule D, Part II states the following:

The following are the specific objectives of a records review:

1. To obtain and review records that relate to the Phase I (One) property and to the current and past uses of and activities at or affecting the Phase I (One) property in order to determine if an area of potential environmental concern exists and to interpret any area of potential environmental concern.
2. To obtain and review records that relate to properties in the Phase I (One) study area other than the Phase I (One) property, in order to determine if an area of potential environmental concern exists and to interpret any area of potential environmental concern.

It is therefore reasonable to request that the HLUI search be included in the Phase I ESA to meet the above objectives.

Please submit.

All existing reports and plans will need to be revised if older than 2 years and must reflect current City Standards, Guidelines, By-laws and Policies.

Please refer to City of Ottawa website portal for **“Guide to preparing Studies and Plans”** at <https://ottawa.ca/en/city-hall/planning-and-development/information-developers/development-application-review-process/development-application-submission/guide-preparing-studies-and-plans>.

Please ensure you are using the current guidelines, bylaws and standards including materials of construction, disinfection and all relevant reference to OPSS/D and AWWA guidelines - all current and as amended, such as:

City of Ottawa Sewer Design Guidelines (CoOSDG) complete with all current and relative ISTB technical bulletin updates as well as current Sewer, Landscape & Road Standard Detail Drawings as well as Material Specifications (MS Docs).
Sewer Connection (2003-513) & Sewer Use (2003-514) By-Laws.

City of Ottawa Water Distribution Design Guidelines (CoOWDDG) complete with all current and relative ISTB technical bulletin updates as well as current Watermain/ Services Material Specifications (MS Docs) as well as Water and Road Standard Detail Drawings.
FUS Fire Flow standards
Water (2018-167) By-Law

Ensure to include version date and add **“(as amended)”** when referencing all standards, detail drawings, by-Laws and guidelines.

Fourth (4th) Review Charge:

Please be advised that additional charges for each review, after the 3rd review, will be applicable to each file. There will be no exceptions.

Construction approach – Please contact the Right-of-Ways Permit Office (TMconstruction@ottawa.ca) early in the zoning and site plan process to determine the ability to construct site and copy Andrew McCreight on this request.

Contact me by e-mail at shawn.wessel@ottawa.ca if you have any questions.

Sincerely,

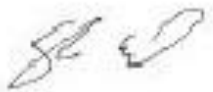

Shawn Wessel, A.Sc.T., rcji
Project Manager
Development Review, Central Branch

October 22, 2025

Ken Hoppner
Hoppner Holdings Inc.
Via email: khoppner@morleyhoppner.com

**Subject: Pre-Consultation: Meeting Feedback
Proposed Zoning By-law Amendment Application and Site Plan
Revision (Re-Circulation) – 314, 318 Athlone and 2006, 2020, 2026 Scott
Street**

Please find below information regarding next steps as well as consolidated comments from the above-noted pre-consultation meeting held on October 2, 2025.

Pre-Consultation Preliminary Assessment

Next Steps

1. A review of the proposal and materials submitted for the above-noted pre-consultation has been undertaken. For your next submission, please submit the required Application Form, together with the necessary studies and/or plans to planningcirculations@ottawa.ca, copy (cc:) to the file lead and planning support.
2. In your subsequent pre-consultation or application submission, please ensure that all comments or issues detailed herein are addressed. A detailed cover letter stating how each issue has been addressed is requested with the submission materials. Please coordinate the numbering of your responses within the cover letter with the comment number(s) herein.
3. Please note, if your development proposal changes significantly in scope, design, or density it is recommended that a subsequent pre-consultation application be submitted.
4. If the Urban Design Review Panel (UDRP) Report is listed as a required submission material in the Study and Plan Identification List, the applicant must visit the UDRP prior to formally submitting the planning application. The UDRP report is required for the application to be considered complete.

Supporting Information and Material Requirements

1. The attached **Study and Plan Identification List** outlines the information and material that has been identified, during this phase of pre-consultation, as either required (R) or advised (A) as part of a future complete application submission.

- a. The required plans and studies must meet the City's Terms of Reference (ToR) and/or Guidelines, as available on Ottawa.ca. These ToR and Guidelines outline the specific requirements that must be met for each plan or study to be deemed adequate.

Consultation with Technical Agencies

1. You are encouraged to consult with technical agencies early in the development process and throughout the development of your project concept. A list of technical agencies and their contact information is enclosed.

Planning

Comments:

1. Staff have strong concerns with the proposed vehicular access and turnaround provided from Scott Street. Investigate opportunities to improve the interior pedestrian courtyard to ensure prioritization of pedestrian use, safety and enjoyment of this space. The pedestrian plaza should operate primarily as a connection from Scott Street to Lion's Park and should functionally represent a continuation of leisure space through high-quality landscaping, amenity area, seating areas, and tree plantings. Please see below some considerations:
 - a. Further activation of this space through the ground level uses of the towers should also be considered, in addition to mitigation of any wind impacts on the pedestrian level amenity areas resulting from additional buildings on site.
 - b. The proposed at-grade drive aisle from Scott Street prioritizes automobile use of the internal pedestrian plaza and introduces potential conflicts on-site between vehicles and pedestrians. Landscaping should be designed to prioritize pedestrians and should utilize markings to mitigate conflict where vehicles are anticipated, and width requirements for fire routes, waste, and snow removal should also be considered.
 - c. Official Plan policies direct vehicular entrances to the road with the lowest classification, as such additional access from Scott Street is not appropriate.
 - d. Staff encourage further discussions pertaining to the design of vehicular circulation through the site. Site access via Ashton Avenue will need to be further discussed internally should this be a preferred option.
2. Please reduce the number of private approaches entering the site from Scott Street. Numerous entrances present concerns as well as they represent an increased amount of vehicular turning movements on Scott Street in close

proximity to each other. OP Policies note that there should not be a net increase of private approaches onto the site.

3. Regarding the three parallel parking spaces located at-grade. Please investigate opportunities to provide for visitor or drop off parking spaces as per the OP policies, which note that parking must be screened from the public realm. This can be achieved by locating the spaces behind a building, as well as locating them underground or within the building, which the current design does not achieve.
4. Staff have concerns with the proposed density and massing immediately adjacent to the park. The two-tower proposal provides for stepping and transition to an appropriate massing adjacent to the park. In the current configuration, a 22-storey massing atop a 6-storey podium is provided in close proximity to the park. Further transition and separation should be provided, and lesser heights should be contemplated for Building 2.
 - a. A low-rise podium, similar to the proposal on the adjacent lands to the west, should be provided for building 2 to ensure adequate transition and pedestrian scale are provided abutting the public park.
 - b. A reduction in tower height would also be appropriate.
5. An analysis of the 45-degree angular planes, for both the two-tower and three-tower proposals, would be helpful in determining the appropriate tower height and required transition for Building 2 moving forward.
6. Regarding massing and transition for Building 3 on the north-east of the site, the 6-storey podium along Scott Street should consider stepping down to a low-rise podium massing along Athlone to replicate and represent the low-rise residential character of street.
7. If proceeding with a Zoning By-law Amendment for a three-tower concept, Staff will be including a density cap consistent with the density permitted through the current zoning by-law provisions applying to the site, which speak to a maximum GFA. Maximum heights will generally be left flexible to allow for density redistribution on the subject lands, subject to the current 40-storey maximum height. However, as per comment 4 above, it is recommended one of the towers along Scott remain at 40-storeys allowing Building 2 to further reduce height.
8. Please provide large-household dwelling units which meet or exceed the targets set by the Official Plan, to support for a diversity of residents within the neighbourhood.
9. Please provide for a 1:1 ratio for bicycle parking spaces per dwelling unit to promote multi-modal transportation. This is particularly important given the proximity of the LRT station.

10. Section 37 requirements / Community Benefits Charge

- a. The former Section 37 regime has been replaced with a “Community Benefits Charge”, By-law No. 2022-307, as amended. This charge will be required for ALL buildings that are 5 or more storeys and 10 or more units and will be required at the time of building permit unless the development is subject to an existing registered Section 37 agreement. The CBC by-law may be subject to change as per the recent Housing Task Force report and pending implementing by-law amendments. Questions regarding this change can be directed to Ranbir.Singh@ottawa.ca.

Urban Design

Comments:

Submission Requirements:

11. Urban Design Brief is required. Please see attached updated Terms of Reference to guide the preparation.
12. Drawings and studies are required as shown on the SPIL. Please follow the terms of references ([Planning application submission information and materials | City of Ottawa](#)) to prepare these drawings and studies. These include:
 - a. Site Plan
 - b. Landscape Plan
 - c. Building Elevations
 - d. Wind study
 - e. Shadow study

UDRP Review:

13. The site is within a Design Priority Area. UDRP review is required given the substantial changes in the revised proposal. Please contact udrp@ottawa.ca for scheduling details. Early consultation with the UDRP is highly recommended. If UDRP review occurs at preconsultation stage, a URRP report is required to ensure process transparency ([Urban Design Review Panel Report](#)).

Comments on Preliminary Concept:

14. Site Organization

- a. Urban design has concerns regarding site organization, particularly the use of the pedestrian plaza as a fire route.

- b. Alternate access for underground parking, waste collection and fire route should be explored. A potential option could include providing laneway on the west of the site from Scott Street to serve the purpose. Or a driveway off Athlone.
- c. The ground floor of three towers needs to have active pedestrian uses so that all public streets, the pedestrian plaza, and the park is well animated.
- d. Minimize curb cuts on all streets.
- e. Loading and other back of house facilities should be internalized and screened from public views

15. Built Form and Massing

- a. 6-storey podium with setbacks and articulation that supports human scale can be appropriate for Scott Street.
- b. Recognizing the predominately low-rise context along Athlone Ave, please consider limiting podium height to maximum 4-storeys provide appropriate transition.
- c. 6-storey podium is too tall for Tower 2. A low-rise podium with fine-grain articulation, is similar to the proposed development at the abutting property to the west, can be appropriate.
- d. Built form design must minimize wind and shadow impacts on abutting public realm and private properties.

16. Public Realm and Landscaping

- a. Creating a generous, comfortable, and attractive pedestrian space that connects Scott Street and Lions Park is crucial for this development. This space should be free from any conflict with vehicles. Consider reducing the footprint of the phase 2 development and moving tower 2 further west so that a wider and more open connection can be created.
- b. Provide additional building setback at the corner of Scott and Athlone to create a plaza facing the LRT station to accommodate anticipated heavy foot traffic and potential patios.
- c. Ensure the pedestrian realm along Scott and Athlone, including the location of street trees, are consistent with the rest of the streets.
- d. Landscape measures may be required to mitigate excessive wind impacts.

Feel free to contact Sahara Shrestha, or Randolph Wang, Urban Design, for follow-up questions.

Engineering

Comments:

17. Site Servicing and Stormwater Management Report

- a. Report must be updated as per revised concept.
- b. Please send an email to Mohammed.Fawzi@ottawa.ca with the anticipated sanitary peak flow to verify sanitary capacity. Please also include sanitary peak flow from original concept as well.
- c. Stormwater management quantity and quality control criteria to remain the same as per previous criteria applied in the original concept.
- d. Please send a request for updated boundary conditions:
 - I. Water Boundary condition requests must include the location of the service (map or plan with connection location(s) indicated) and the expected loads required by the proposed development, including calculations. Please provide the following information:
 1. Location of service
 2. Type of development and the amount of fire flow required (as per FUS).
 3. Average daily demand: ___ l/s.
 4. Maximum daily demand: ___ l/s.
 5. Maximum hourly daily demand: ___ l/s.

18. Geotechnical Study

- a. If previous report to be used, please ensure the report is updated as per the revised concept and that all recommendations and conclusions are updated accordingly.

19. Civil Plans (Grading, Servicing, Erosion & Sediment Control Plan, etc.)

- a. Please ensure all civil plans are updated accordingly as per the new concept plan.

20. Phase One Environmental Site Assessment. Please note that as per O.Reg153/04 a Phase I ESA must be updated if it is older than 18 months.

- a) A Phase I ESA is required to be completed in accordance with Ontario Regulation 153/04 in support of this development proposal to determine

the potential for site contamination. Depending on the Phase I recommendations a Phase II ESA may be required.

- b) The Phase I ESA shall provide all the required Environmental Source Information as required by O. Reg. 153/04. ERIS records are available to public at a reasonable cost and need to be included in the ESA report to comply with O.Reg. 153/04 and the Official Plan. The City will not be in a position to approve the Phase I ESA without the inclusion of the ERIS reports.
- c) Official Plan Section 10.1.6
- d) Record of Site Condition (RSC) will be required (for Site Plan Approval).

21. Construction Approach

- a. Please contact the Right-of-Ways Permit Office Mconstruction@ottawa.ca early in the Site Plan process to determine the ability to construct site and copy File Lead on this request.

Feel free to contact Mohammed Fawzi, Senior Project Manager, for follow-up questions.

Noise

Comments:

- 22. Noise Control Study: Please ensure the Noise Control Study is updated as per the revised concept. Please ensure a vibration component is included due to LRT station proximity.

Feel free to contact Mohammed Fawzi, Senior Project Manager, for follow-up questions.

Transportation

Comments:

- 23. Right-of-way protection.
 - a. See [Schedule C16 of the Official Plan](#).
 - b. Any requests for exceptions to ROW protection requirements must be discussed with Transportation Planning and concurrence provided by Transportation Planning management.
- 24. The Screening Form has indicated that the Location Triggers have been met, a TIA Memorandum would be required as an overview of the proposed development.

25. A 3.0 metres (along Athlone Avenue) x 9.0 metres (along Scott Street) corner triangle is required at the intersection of Scott Street and Athlone Avenue based on Schedule C16 of the Official Plan. The 3.0 metres x 9.0 metres corner triangles area is to be conveyed to the city and is to be shown on all drawings. The corner triangle dimensions are to be measured from the ROW protected limits. Ensure that the development proposal complies with the Right-of-Way protection requirements of the Official Plan's Schedule C16.
26. Minimum lane width for fire trucks is 6.0 metres. A fire truck three-point turn as it relates to the proposed lane configurations is to be confirmed by the Fire Chief.
27. Permanent structures such as curbing, stairs, retaining walls, and underground parking foundation also bicycle parking racks are not to extend into the corner triangle and City's right-of-way limits.
28. The Owner is responsible for identifying the type and location of existing signage that will be removed from within the Right-of-Way to accommodate the development site. The Owner is responsible for providing the General Manager with a detailed drawing identifying the type and position of the existing signs and roadway pavement markings along the site frontage. A separate pavement markings and signage drawings are to be provided.
29. The Owner shall be required to enter into maintenance and liability agreement for all pavers, plant and landscaping material placed in the City right-of-way and the Owner shall assume all maintenance and replacement responsibilities in perpetuity.
30. Should the property Owner wish to use a portion of the City's Road allowance for construction staging, prior to obtaining a building permit, the property Owner must obtain an approved Traffic Management Plan from the Manager, Traffic Management, Transportation Services Department. The city has the right for any reason to deny use of the Road Allowance and to amend the approved Traffic Management Plan as required.
31. The Owner acknowledges and agrees that all private accesses to Roads shall comply with the City's Private Approach By-Law being By-Law No. 2003-447 as amended <https://ottawa.ca/en/living-ottawa/laws-licences-and-permits/laws/law-z/private-approach-law-no-2003-447> or as approved through the Site Plan control process.

Feel free to contact Wally Dubyk, Transportation Project Manager, for follow-up questions

Environment

Comments:

32. There are no protected natural heritage features, surface water features, or species-at-risk habitat present on or near the site that would trigger the need for an Environmental Impact Statement as part of this application.

An EIS is not required.

33. The City's [Bird Safe Design Guidelines](#) will apply to this development. Please note that Guideline 2 stipulates mitigation measures for 90% of all glazing up to 16m from the ground.

34. The City has strong policies for tree plantings to help reduce the impacts of the urban heat island effect and climate change, as well as to help meet the urban forest canopy goals. Additional tree plantings along Scott Street are highly recommended. Please note that the City prefers that all plantings be of native and non-invasive species.

Feel free to contact Mark Elliott, Environmental Planner, for follow-up questions.

Forestry

Comments:

35. A revised/updated TCR will be required with any subsequent Site Plan Control application. Please contact the Planning Forester if additional information is required.
36. A revised three planting plan (LP) will be required with any subsequent Site Plan Control application. Please contact the Planning Forester if additional information is required.

Feel free to contact Mark Richardson, Planning Forester, for follow-up questions.

Parkland

Comments:

37. Please confirm property boundaries. Submission seems to indicate encroachment onto park property (Lions Park).
38. The Applicant/Owner to acknowledge that a Limiting Distance Agreement will not be permitted for proposed Building 2, abutting and adjacent to Lions Park.
39. The Applicant/Owner acknowledges that Site Plan Agreement conditions of approval will address the existing parkland Base Improvement requirements and said improvements and parkland site remediation works will be provided at no cost to the City.

40. The Applicant/Owner acknowledges that easement access rights on/over existing parkland from Ashton Avenue only apply for Part 3, 5R-14256 and does not extend beyond Part 3.

41. Cash-in-lieu (CILP) of parkland, in accordance with Parkland Dedication By-law No. 2022-280, as amended / parkland dedication will be required. Subject to Councillor concurrence, CILP is to be directed to Lion's Park improvements.

Feel free to contact Mike Russett, Parks Planner, for follow-up questions.

Community issues

Comments:

42. General Observations

- a. The community strongly preferred the earlier two-tower (2T) design, which was well received for its balance of density, public realm integration, and sensitivity to its surroundings. The UDRP shared this opinion in their reviews of September 2022 and July 2023. However, the three-tower (3T) concept represents a significant departure from that approach and raises several concerns related to traffic, park impacts, and livability.
- b. We believe these issues merit further review and adjustment to better align with City policy objectives and community expectations.

43. Site Context and Design Integration

- a. The site sits between busy Scott Street and the well-used Lion's Park. The 2T design successfully recognized this dual context, providing a welcoming pedestrian corridor that linked the park to Scott Street and the LRT beyond.
- b. By contrast, the 3T proposal replaces this pedestrian-focused design with a more fragmented layout, reducing visual and physical connection between the community and the park.

44. Vehicular Access and Active Transportation

- a. 2T: featured a single access from Scott Street, minimizing conflicts with the Crosstown Cycle route and sidewalk.
- b. 3T: introduces a second private roadway crossing both the sidewalk and cycle route. This would bring frequent service and delivery vehicle movements into an area heavily used by pedestrians, cyclists, strollers, and wheelchairs. This would create potential safety and comfort concerns.

- c. We recommend re-examining vehicle access options. For example, using Ashton Avenue for fire and service access to Building 2 could reduce these conflicts. An updated traffic study should also be undertaken to assess the impacts of the revised layout.

45. Parkland and Relationship to Lion's Park

- a. The 2T proposal provided dedicated public parkland, a key benefit for a neighbourhood already short on greenspace given ongoing intensification.
- b. In the 3T version, a tower is now proposed on the former park parcel, with a narrow courtyard between B1 and B2 suggested as a substitute. However, this space would be enclosed on three sides by high-rise buildings and would not function as meaningful parkland.
- c. Moreover, the 2T design's terraced south façade created a softer transition to the park and an attractive visual interface. The 3T proposal, by contrast, presents a tall, flat building face directly on the park edge, reducing openness and shadowing park users.

46. Resident Experience and Phasing

- a. Under the 3T proposal, residents of Building 1 would initially face the park but soon lose that view as Building 2 is constructed. This extended multi-phase buildout may result in long-term construction impacts and reduced livability for early residents.
- b. The community questions whether this design approach will attract stable, long-term tenants compared to the more integrated and complete 2T concept.

47. Amenities and Community Spaces

- a. The 2T design included a shared, well-equipped gym and common area linked by a bridge. This is an efficient and community-oriented approach.
- b. The 3T plans do not clearly indicate how amenities will be provided across the three buildings. Will facilities be centralized for all residents, or duplicated at a smaller scale within each tower? This is an important detail that affects both livability and design quality.

48. Vision and Community Fit

- a. The two-tower design was viewed as a landmark gateway to Lion's Park and Westboro, integrating transit, cycling, park access, and residential life into a cohesive whole.

- b. The three-tower proposal, in contrast, feels more conventional and disconnected from its unique setting. We encourage the design team to revisit the earlier 2T concept as a foundation for refinement rather than replacement.

Feel free to contact Scott Burton or Tim Gray, Westboro Community Association, with follow-up questions.

Other

49. The High Performance Development Standard (HPDS) is a collection of voluntary and required standards that raise the performance of new building projects to achieve sustainable and resilient design and will be applicable to Site Plan Control and Plan of Subdivision applications.

- a. The HPDS was passed by Council on April 13, 2022, but is not in effect at this time, as Council has referred the 2023 HPDS Update Report back to staff with the direction to bring forward an updated report to Committee at a later date. The timing of an updated report to Committee is unknown at this time, and updates will be shared when they are available.
- b. Please refer to the HPDS information at ottawa.ca/HPDS for more information.

50. Under the Affordable Housing Community Improvement Plan, a Tax Increment Equivalent Grant (TIEG) program was created to incentivize the development of affordable rental units. It provides a yearly fixed grant for 20 years. The grant helps offset the revenue loss housing providers experience when incorporating affordable units in their developments.

- a. To be eligible for the TIEG program you must meet the following criteria:
 - i. the greater of five units OR 15 per cent of the total number of units within the development must be made affordable
 - ii. provide a minimum of 15 per cent of each unit type in the development as affordable
 - iii. enter into an agreement with the city to ensure the units maintain affordable for a minimum period of 20 years at or below the city-wide average market rent for the entire housing stock based on building form and unit type, as defined by the Canada Mortgage and Housing Corporation
 - iv. must apply after a formal Site Plan Control submission, or Building Permit submission for projects not requiring Site Plan Control, and prior to Occupancy Permit issuance

- b. Please refer to the TIEG information at [Affordable housing community improvement plan / Plan d'améliorations communautaires pour le logement abordable](#) for more details or contact the TIEG coordinator via email at affordablehousingcip@ottawa.ca.

Submission Requirements and Fees

1. The submission of a new Minor Zoning By-law Amendment will be required for this application. The ongoing Site Plan Control (D07-12-23-0019) application can be modified to reflect the three-tower proposal upon resubmission and recirculation, at a fee.
 - a. Additional information regarding fees related to planning applications can be found [here](#).
2. The attached **Study and Plan Identification List** outlines the information and material that has been identified as either required (R) or advised (A) as part of a future complete application submission.
 - a. The required plans and studies must meet the City's Terms of Reference (ToR) and/or Guidelines, as available on Ottawa.ca. These ToR and Guidelines outline the specific requirements that must be met for each plan or study to be deemed adequate.
3. All of the above comments or issues should be addressed to ensure the effectiveness of the application submission review.

Should there be any questions, please do not hesitate to contact myself or the contact identified for the above areas / disciplines.

Yours Truly,

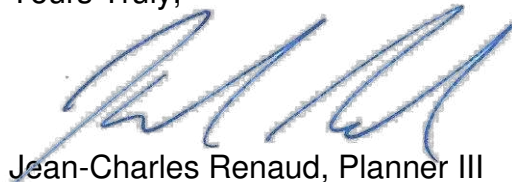

Jean-Charles Renaud, Planner III

Encl. Study Plan Identification List
List of Technical Agencies
Development Information Sheet
City of Ottawa Accessible Design Standards – Site Plan Checklist
High Performance Development Standards Overview
Urban Design Brief Terms of Reference

c.c. Jack Smith, Planner II
Leah Dykstra, Planner I
Randolph Wang, Urban Designer
Mohammed Fawzi, Infrastructure Project Manager



Wally Dubyk, Transportation Project Manager

Mark Elliot, Environmental Planner

Mark Richardson, Planning Forester

Mike Russett, Parks Planner

Tim Gray, Westboro Community Association, tim.gray@sympatico.ca

Scott Burton, Westboro Community Association, scottrburton@gmail.com

Steve Matthews

From: Jamie Batchelor <jamie.batchelor@rvca.ca>
Sent: Tuesday, April 5, 2022 9:18 AM
To: Francois Thauvette
Cc: Steve Matthews; Eric Lalande
Subject: RE: 2026 Scott St - Pre-Consultation with the RVCA

Good Morning Francois,

I apologize for the delay. It looks like this came in around the time I went off on leave. I can confirm that based on the parking being underground and the development consisting of rooftop drainage and landscaping, the RVCA would not require additional on-site water quality measures save and except best management practices.

From: Francois Thauvette <f.thauvette@novatech-eng.com>
Sent: Friday, April 1, 2022 12:43 PM
To: Jamie Batchelor <jamie.batchelor@rvca.ca>
Cc: Steve Matthews <S.Matthews@novatech-eng.com>
Subject: RE: 2026 Scott St - Pre-Consultation with the RVCA

Hi Jamie,

I sent you the e-mail below back in December 2021, but do not recall receiving a response. Please review the e-mail below and provide a response so that we may finalize our servicing and SWM report? Also attached is the updated conceptual Site Plan.

Regards,

François Thauvette, P. Eng., Senior Project Manager | Land Development & Public Sector Engineering

NOVATECH Engineers, Planners & Landscape Architects

Please note that I am working from home. Email or MS Teams are the best ways to contact me.

240 Michael Cowpland Drive, Suite 200, Ottawa, ON, K2M 1P6 | Tel: 613.254.9643 Ext: 219 | Cell: 613.276.0310 | Fax: 613.254.5867

The information contained in this email message is confidential and is for exclusive use of the addressee.

From: Francois Thauvette <f.thauvette@novatech-eng.com>
Sent: Wednesday, December 8, 2021 11:55 AM
To: jamie.batchelor@rvca.ca
Cc: Steve Matthews <S.Matthews@novatech-eng.com>
Subject: 2026 Scott St - Pre-Consultation with the RVCA

Hi Jamie,

We are working on a proposed multi-tower high-rise residential development located at 2026 Scott Street in Ottawa (see attached conceptual Site Plan). The proposed development will include three (3) high-rise towers (ranging from 20 to 40-storeys), exterior amenity space and underground parking. We are sending this e-mail to ask the RVCA to confirm if there are any stormwater management (quality control criteria) requirements for this site. Based on recent RVCA correspondence (for a new project at 1950 Scott Street) stormwater quality control measures are not required due to the nature of the development, the fact that all parking will be underground (i.e. no surface parking) and that the distance to the stormwater outlet is >2km downstream. Please confirm if this is also applicable to the proposed development.

Regards,

François Thauvette, P. Eng., Senior Project Manager | Land Development & Public Sector Engineering

NOVATECH Engineers, Planners & Landscape Architects

Please note that I am working from home. Email or MS Teams are the best ways to contact me.

240 Michael Cowpland Drive, Suite 200, Ottawa, ON, K2M 1P6 | Tel: 613.254.9643 Ext: 219 | Cell: 613.276.0310 | Fax: 613.254.5867

The information contained in this email message is confidential and is for exclusive use of the addressee.

APPENDIX B
Development Servicing Study Checklist

Servicing study guidelines for development applications

4. Development Servicing Study Checklist

The following section describes the checklist of the required content of servicing studies. It is expected that the proponent will address each one of the following items for the study to be deemed complete and ready for review by City of Ottawa Infrastructure Approvals staff.

The level of required detail in the Servicing Study will increase depending on the type of application. For example, for Official Plan amendments and re-zoning applications, the main issues will be to determine the capacity requirements for the proposed change in land use and confirm this against the existing capacity constraint, and to define the solutions, phasing of works and the financing of works to address the capacity constraint. For subdivisions and site plans, the above will be required with additional detailed information supporting the servicing within the development boundary.

4.1 General Content

- Executive Summary (for larger reports only).
- Date and revision number of the report.
- Location map and plan showing municipal address, boundary, and layout of proposed development.
- Plan showing the site and location of all existing services.
- Development statistics, land use, density, adherence to zoning and official plan, and reference to applicable subwatershed and watershed plans that provide context to which individual developments must adhere.
- Summary of Pre-consultation Meetings with City and other approval agencies.
- Reference and confirm conformance to higher level studies and reports (Master Servicing Studies, Environmental Assessments, Community Design Plans), or in the case where it is not in conformance, the proponent must provide justification and develop a defensible design criteria.
- Statement of objectives and servicing criteria.
- Identification of existing and proposed infrastructure available in the immediate area.
- Identification of Environmentally Significant Areas, watercourses and Municipal Drains potentially impacted by the proposed development (Reference can be made to the Natural Heritage Studies, if available).
- Concept level master grading plan to confirm existing and proposed grades in the development. This is required to confirm the feasibility of proposed stormwater management and drainage, soil removal and fill constraints, and potential impacts to neighbouring properties. This is also required to confirm that the proposed grading will not impede existing major system flow paths.
- Identification of potential impacts of proposed piped services on private services (such as wells and septic fields on adjacent lands) and mitigation required to address potential impacts.
- Proposed phasing of the development, if applicable.

- Reference to geotechnical studies and recommendations concerning servicing.

- All preliminary and formal site plan submissions should have the following information:
 - Metric scale

 - North arrow (including construction North)

 - Key plan

 - Name and contact information of applicant and property owner

 - Property limits including bearings and dimensions

 - Existing and proposed structures and parking areas

 - Easements, road widening and rights-of-way

 - Adjacent street names

4.2 Development Servicing Report: Water

- Confirm consistency with Master Servicing Study, if available
- Availability of public infrastructure to service proposed development
- Identification of system constraints
- Identify boundary conditions
- Confirmation of adequate domestic supply and pressure
- Confirmation of adequate fire flow protection and confirmation that fire flow is calculated as per the Fire Underwriter's Survey. Output should show available fire flow at locations throughout the development.
- Provide a check of high pressures. If pressure is found to be high, an assessment is required to confirm the application of pressure reducing valves.
- Definition of phasing constraints. Hydraulic modeling is required to confirm servicing for all defined phases of the project including the ultimate design
- Address reliability requirements such as appropriate location of shut-off valves
- Check on the necessity of a pressure zone boundary modification.
- Reference to water supply analysis to show that major infrastructure is capable of delivering sufficient water for the proposed land use. This includes data that shows that the expected demands under average day, peak hour and fire flow conditions provide water within the required pressure range

- Description of the proposed water distribution network, including locations of proposed connections to the existing system, provisions for necessary looping, and appurtenances (valves, pressure reducing valves, valve chambers, and fire hydrants) including special metering provisions.
- Description of off-site required feeder mains, booster pumping stations, and other water infrastructure that will be ultimately required to service proposed development, including financing, interim facilities, and timing of implementation.
- Confirmation that water demands are calculated based on the City of Ottawa Design Guidelines.
- Provision of a model schematic showing the boundary conditions locations, streets, parcels, and building locations for reference.

4.3 Development Servicing Report: Wastewater

- Summary of proposed design criteria (Note: Wet-weather flow criteria should not deviate from the City of Ottawa Sewer Design Guidelines. Monitored flow data from relatively new infrastructure cannot be used to justify capacity requirements for proposed infrastructure).
- Confirm consistency with Master Servicing Study and/or justifications for deviations.
- Consideration of local conditions that may contribute to extraneous flows that are higher than the recommended flows in the guidelines. This includes groundwater and soil conditions, and age and condition of sewers.
- Description of existing sanitary sewer available for discharge of wastewater from proposed development.
- Verify available capacity in downstream sanitary sewer and/or identification of upgrades necessary to service the proposed development. (Reference can be made to previously completed Master Servicing Study if applicable)
- Calculations related to dry-weather and wet-weather flow rates from the development in standard MOE sanitary sewer design table (Appendix 'C') format.
- Description of proposed sewer network including sewers, pumping stations, and forcemains.
- Discussion of previously identified environmental constraints and impact on servicing (environmental constraints are related to limitations imposed on the development in order to preserve the physical condition of watercourses, vegetation, soil cover, as well as protecting against water quantity and quality).
- Pumping stations: impacts of proposed development on existing pumping stations or requirements for new pumping station to service development.
- Forcemain capacity in terms of operational redundancy, surge pressure and maximum flow velocity.
- Identification and implementation of the emergency overflow from sanitary pumping stations in relation to the hydraulic grade line to protect against basement flooding.
- Special considerations such as contamination, corrosive environment etc.

4.4 Development Servicing Report: Stormwater Checklist

- Description of drainage outlets and downstream constraints including legality of outlets (i.e. municipal drain, right-of-way, watercourse, or private property)
- Analysis of available capacity in existing public infrastructure.
- A drawing showing the subject lands, its surroundings, the receiving watercourse, existing drainage patterns, and proposed drainage pattern.
- Water quantity control objective (e.g. controlling post-development peak flows to pre-development level for storm events ranging from the 2 or 5 year event (dependent on the receiving sewer design) to 100 year return period); if other objectives are being applied, a rationale must be included with reference to hydrologic analyses of the potentially affected subwatersheds, taking into account long-term cumulative effects.
- Water Quality control objective (basic, normal or enhanced level of protection based on the sensitivities of the receiving watercourse) and storage requirements.
- Description of the stormwater management concept with facility locations and descriptions with references and supporting information.
- Set-back from private sewage disposal systems.
- Watercourse and hazard lands setbacks.
- Record of pre-consultation with the Ontario Ministry of Environment and the Conservation Authority that has jurisdiction on the affected watershed.
- Confirm consistency with sub-watershed and Master Servicing Study, if applicable study exists.
- Storage requirements (complete with calculations) and conveyance capacity for minor events (1:5 year return period) and major events (1:100 year return period).
- Identification of watercourses within the proposed development and how watercourses will be protected, or, if necessary, altered by the proposed development with applicable approvals.
- Calculate pre and post development peak flow rates including a description of existing site conditions and proposed impervious areas and drainage catchments in comparison to existing conditions.
- Any proposed diversion of drainage catchment areas from one outlet to another.
- Proposed minor and major systems including locations and sizes of stormwater trunk sewers, and stormwater management facilities.
- If quantity control is not proposed, demonstration that downstream system has adequate capacity for the post-development flows up to and including the 100 year return period storm event.
- Identification of potential impacts to receiving watercourses
- Identification of municipal drains and related approval requirements.
- Descriptions of how the conveyance and storage capacity will be achieved for the development.
- 100 year flood levels and major flow routing to protect proposed development from flooding for establishing minimum building elevations (MBE) and overall grading.

- Inclusion of hydraulic analysis including hydraulic grade line elevations.
- Description of approach to erosion and sediment control during construction for the protection of receiving watercourse or drainage corridors.
- Identification of floodplains – proponent to obtain relevant floodplain information from the appropriate Conservation Authority. The proponent may be required to delineate floodplain elevations to the satisfaction of the Conservation Authority if such information is not available or if information does not match current conditions.
- Identification of fill constraints related to floodplain and geotechnical investigation.

4.5 Approval and Permit Requirements: Checklist

The Servicing Study shall provide a list of applicable permits and regulatory approvals necessary for the proposed development as well as the relevant issues affecting each approval. The approval and permitting shall include but not be limited to the following:

- Conservation Authority as the designated approval agency for modification of floodplain, potential impact on fish habitat, proposed works in or adjacent to a watercourse, cut/fill permits and Approval under Lakes and Rivers Improvement Act. The Conservation Authority is not the approval authority for the Lakes and Rivers Improvement Act. Where there are Conservation Authority regulations in place, approval under the Lakes and Rivers Improvement Act is not required, except in cases of dams as defined in the Act.
- Application for Certificate of Approval (CofA) under the Ontario Water Resources Act.
- Changes to Municipal Drains.
- Other permits (National Capital Commission, Parks Canada, Public Works and Government Services Canada, Ministry of Transportation etc.)

4.6 Conclusion Checklist

- Clearly stated conclusions and recommendations
- Comments received from review agencies including the City of Ottawa and information on how the comments were addressed. Final sign-off from the responsible reviewing agency.
- All draft and final reports shall be signed and stamped by a professional Engineer registered in Ontario

APPENDIX C
Preliminary Sanitary Sewage Calculations

2026 SCOTT STREET POST-DEVELOPMENT SANITARY FLOWS - SUMMARY

Residential and Commercial Uses	Peak Flows (L/s)
Building 1	5.16
Subtotal - Building 1 Outlet	5.16
Building 2	6.68
Building 3	3.57
Subtotal - Building 2 Outlet	10.25
Total Peak Sanitary Flow	15.41

2026 SCOTT STREET - BUILDING 1 POST-DEVELOPMENT SANITARY FLOWS

Residential Flows	Post-Development
Number of Studio / 1-Bedroom Units	195
Persons per Studio / 1-Bedroom Unit	1.4
Number of 2-Bedroom Units	90
Persons per 2-Bedroom Unit	2.1
Total Number of Units	285
Design Population	462
Average Daily Flow (280L/c/day)	1.50
Peak Factor (Harmon Formula)	3.39
Peak Residential Flow	5.08 L/s
Commercial Flows	
Ground Floor Area	178 m ²
Average Commercial Daily Demand	2.8 L/m ² /day
Peaking Factor (<20% Commercial Contribution)	1.0
Peak Commercial Flows	0.01 L/s
Extraneous Flow	
Tower Site Area	0.214 ha
Infiltration Allowance	0.33 L/s/ha
Peak Extraneous Flow	0.07 L/s
Total Peak Sanitary Flow	5.16 L/s

**2026 SCOTT STREET - BUILDING 2
 POST-DEVELOPMENT SANITARY FLOWS**

Residential Flows	Post-Development	
Number of Studio / 1-Bedroom Units	265	
Persons per Studio / 1-Bedroom Unit	1.4	
Number of 2-Bedroom Units	113	
Persons per 2-Bedroom Unit	2.1	
Total Number of Units	378	
Design Population	609	
Average Daily Flow (280L/c/day)	1.97	
Peak Factor (Harmon Formula)	3.34	
Peak Residential Flow	6.60	L/s
Extraneous Flow		
Tower Site Area	0.252	ha
Infiltration Allowance	0.33	L/s/ha
Peak Extraneous Flow	0.08	L/s
Total Peak Sanitary Flow	6.68 L/s	

**2026 SCOTT STREET - BUILDING 3
 POST-DEVELOPMENT SANITARY FLOWS**

Residential Flows	Post-Development	
Number of Studio / 1-Bedroom Units	136	
Persons per Studio / 1-Bedroom Unit	1.4	
Number of 2-Bedroom Units	58	
Persons per 2-Bedroom Unit	2.1	
Total Number of Units	194	
Design Population	313	
Average Daily Flow (280L/c/day)	1.01	
Peak Factor (Harmon Formula)	3.46	
Peak Residential Flow	3.51	L/s
Extraneous Flow		
Tower Site Area	0.194	ha
Infiltration Allowance	0.33	L/s/ha
Peak Extraneous Flow	0.06	L/s
Total Peak Sanitary Flow	3.57	L/s

Kynan Dsa

From: Fawzi, Mohammed <mohammed.fawzi@ottawa.ca>
Sent: Monday, January 19, 2026 7:51 AM
To: Francois Thauvette
Cc: Wu, John; Kynan Dsa
Subject: RE: 2026 Scott Street - D07-12-23-0019 - Anticipated Peak Sanitary Flows (121302)

Hi Francois,

No concerns with the proposed sanitary peak flow. Thank you.

Best Regards,

Mohammed Fawzi, P.Eng.

Senior Project Manager (A), Infrastructure Projects

Development Review – West Branch

Planning, Development and Building Services Department (PDBS)| Direction générale des services de la planification, de l'aménagement et du bâtiment (DGSPAB)

City of Ottawa | Ville d'Ottawa

110 Laurier Avenue West | 110 Avenue Laurier Ouest

Ottawa, ON K1P 1J1

613.580.2424 ext./poste 70120, Mohammed.Fawzi@ottawa.ca

Classified as City of Ottawa - Internal / Ville d'Ottawa - classé interne

From: Fawzi, Mohammed
Sent: January 16, 2026 8:33 AM
To: Francois Thauvette <f.thauvette@novatech-eng.com>
Cc: Wu, John <John.Wu@ottawa.ca>; Kynan Dsa <k.dsa@novatech-eng.com>
Subject: RE: 2026 Scott Street - D07-12-23-0019 - Anticipated Peak Sanitary Flows (121302)

Hi Francois,

This email is to confirm that your request has been received and forwarded to our Water Resources Group for capacity review.

Results will be shared as soon as they are received.

Best Regards,

Mohammed Fawzi, P.Eng.

Senior Project Manager (A), Infrastructure Projects

Development Review – West Branch

Planning, Development and Building Services Department (PDBS)| Direction générale des services de la planification, de l'aménagement et du bâtiment (DGSPAB)
City of Ottawa | Ville d'Ottawa
110 Laurier Avenue West | 110 Avenue Laurier Ouest
Ottawa, ON K1P 1J1
613.580.2424 ext./poste 70120, Mohammed.Fawzi@ottawa.ca

From: Francois Thauvette <f.thauvette@novatech-eng.com>
Sent: January 15, 2026 4:52 PM
To: Fawzi, Mohammed <mohammed.fawzi@ottawa.ca>
Cc: Wu, John <John.Wu@ottawa.ca>; Kynan Dsa <k.dsa@novatech-eng.com>
Subject: FW: 2026 Scott Street - D07-12-23-0019 - Anticipated Peak Sanitary Flows (121302)

CAUTION: This email originated from an External Sender. Please do not click links or open attachments unless you recognize the source.

ATTENTION : Ce courriel provient d'un expéditeur externe. Ne cliquez sur aucun lien et n'ouvrez pas de pièce jointe, excepté si vous connaissez l'expéditeur.

Hi Mohammed,

We are sending you this e-mail to provide the anticipated peak sanitary flows for the proposed **3-tower** re-development of the subject site. See e-mail below and attached calculations for details.

Regards,

François Thauvette, P. Eng., Sr. Project Manager | Land Development & Public-Sector Engineering

NOVATECH

Engineers, Planners & Landscape Architects

240 Michael Cowpland Drive, Suite 200, Ottawa, ON, K2M 1P6 | T: 613.254.9643 Ext: 219 | C: 613.276.0310

The information contained in this email message is confidential and is for exclusive use of the addressee.

From: Kynan Dsa <k.dsa@novatech-eng.com>
Sent: Thursday, January 15, 2026 4:37 PM
To: Francois Thauvette <f.thauvette@novatech-eng.com>
Subject: RE: 2026 Scott Street - D07-12-23-0019 - Anticipated Peak Sanitary Flows (121302)

Hi François,

As requested in the latest pre-consultation notes for the project, please forward this e-mail and attached calculation sheets to the City of Ottawa for the purpose of verifying municipal sanitary sewer capacity.

The configuration of the proposed multi-tower development located at 2026 Scott Street (including other adjacent properties to be merged) has been revised based on direction from the client. The revised proposal will include **three** towers above an underground parking structure instead of the previously

proposed two-tower design. Due to internal mechanical constraints and the phased approach to the development, two separate sanitary services will be required to service Building 1 and Buildings 2 & 3 separately. This approach is similar to the previous (two-tower) servicing design for the site.

Our preference is to generally maintain the previously proposed sanitary servicing design (i.e., Building 1 serviced by the existing 375mm dia. sanitary sewer in Scott Street, Buildings 2 & 3 serviced by the existing 450mm dia. sanitary sewer in Scott Street). The anticipated peak sanitary flow for Building 1 is approximately 5.16 L/s, while the anticipated peak sanitary flow for both Buildings 2 & 3 is approximately 10.25 L/s, for a total peak sanitary flow for the site of **15.41 L/s**. Refer to the attached calculation sheets for details. The anticipated peak sanitary flows for the three-tower design represent a slight **decrease** from the previous two-tower servicing design, which had anticipated peak sanitary flows of 7.34 L/s for the East Tower and 8.36 L/s for the West Tower (**15.70 L/s** total peak sanitary flow for the site).

Thanks,

Kynan D'sa, B.A.Sc. (Engineering) (He/Him)

NOVATECH

Engineers, Planners & Landscape Architects

240 Michael Cowpland Drive, Suite 200, Ottawa, ON, K2M 1P6

Tel: 613.254.9643 Ext. 276 | Cell: 705.821.2278

The information contained in this email message is confidential and is for exclusive use of the addressee.

This e-mail originates from the City of Ottawa e-mail system. Any distribution, use or copying of this e-mail or the information it contains by other than the intended recipient(s) is unauthorized. Thank you.

Le présent courriel a été expédié par le système de courriels de la Ville d'Ottawa. Toute distribution, utilisation ou reproduction du courriel ou des renseignements qui s'y trouvent par une personne autre que son destinataire prévu est interdite. Je vous remercie de votre collaboration.

APPENDIX D

**Preliminary Water Demands, FUS Calculations,
Watermain Boundary Conditions, E-mail
Correspondence from the City of Ottawa, E-mail correspondence
from Architect to support FUS Calculations**

2026 SCOTT STREET POST-DEVELOPMENT WATER DEMANDS SUMMARY

DOMESTIC WATER DEMANDS

Residential and Commercial Uses	Average Day Demand (L/s)	Maximum Day Demand (L/s)	Peak Hour Demand (L/s)
Building 1	1.5	3.8	8.3
Building 2	2.0	4.9	10.9
Building 3	1.0	2.5	5.6
TOTALS	4.5	11.2	24.7

BOUNDARY CONDITIONS (Values provided by the City of Ottawa)

Minimum HGL =	108.5 m
Maximum HGL =	114.6 m
Max Day + Fire Flow (133 L/s) =	104.9 m
Max Day + Fire Flow (150 L/s) =	103.7 m

PRESSURE TESTS

Average Ground Elevation at Connection 63.2 m

Low Pressure Test = (Min. HGL - Watermain Elevation) x 1.42197 PSI/m < 40 PSI
 Min. HGL Pressure = **67.8 PSI**

High Pressure Test = (Max. HGL - Watermain Elevation) x 1.42197 PSI/m = 50-70 PSI
 Max. HGL Pressure = **76.5 PSI**

Max Day + Fire Flow Test = (Max Day + 133 L/s Fire Flow - Watermain Elevation) x 1.42197 PSI/m > 20 PSI
 Max Day + Fire Flow Pressure = **62.7 PSI**

Max Day + Fire Flow Test = (Max Day + 150 L/s Fire Flow - Watermain Elevation) x 1.42197 PSI/m > 20 PSI
 Max Day + Fire Flow Pressure = **61.0 PSI**

2026 SCOTT STREET - BUILDING 1 POST-DEVELOPMENT WATER DEMANDS

DOMESTIC WATER DEMANDS

Residential Water Demands	Post-Development
Number of Studio / 1-Bedroom Units	195
Persons per Studio / 1-Bedroom Unit	1.4
Number of 2-Bedroom Units	90
Persons per 2-Bedroom Unit	2.1
Total Number of Units	285
Design Population	462
Average Daily Flow per resident	280 L/c/day
Average Day Demand	1.50 L/s
Maximum Day Demand (2.5 x avg. day)	3.74 L/s
Peak Hour Demand (2.2 x max. day)	8.23 L/s
Commercial Water Demands	
Ground Floor Area	178 m ²
Average Commercial Daily Demand	2.8 L/m ² /day
Average Day Demand	0.01 L/s
Maximum Day Demand (1.5 x avg. day)	0.01 L/s
Peak Hour Demand (1.8 x max. day)	0.02 L/s
TOTALS	
Average Day Demand	1.5 L/s
Maximum Day Demand	3.8 L/s
Peak Hour Demand	8.3 L/s

2026 SCOTT STREET - BUILDING 2 POST-DEVELOPMENT WATER DEMANDS

DOMESTIC WATER DEMANDS

Residential Water Demands	Post-Development
Number of Studio / 1-Bedroom Units	265
Persons per Studio / 1-Bedroom Unit	1.4
Number of 2-Bedroom Units	113
Persons per 2-Bedroom Unit	2.1
Total Number of Units	378
Design Population	609
Average Daily Flow per resident	280 L/c/day
Average Day Demand	1.97 L/s
Maximum Day Demand (2.5 x avg. day)	4.93 L/s
Peak Hour Demand (2.2 x max. day)	10.85 L/s
TOTALS	
Average Day Demand	2.0 L/s
Maximum Day Demand	4.9 L/s
Peak Hour Demand	10.9 L/s

2026 SCOTT STREET - BUILDING 3 POST-DEVELOPMENT WATER DEMANDS

DOMESTIC WATER DEMANDS

Residential Water Demands	Post-Development
Number of Studio / 1-Bedroom Units	136
Persons per Studio / 1-Bedroom Unit	1.4
Number of 2-Bedroom Units	58
Persons per 2-Bedroom Unit	2.1
Total Number of Units	194
Design Population	313
Average Daily Flow per resident	280 L/c/day
Average Day Demand	1.01 L/s
Maximum Day Demand (2.5 x avg. day)	2.54 L/s
Peak Hour Demand (2.2 x max. day)	5.58 L/s
TOTALS	
Average Day Demand	1.0 L/s
Maximum Day Demand	2.5 L/s
Peak Hour Demand	5.6 L/s

FUS - Fire Flow Calculations



Engineers, Planners & Landscape Architects

Novatech Project #: 121302
 Project Name: 2026 Scott Street - Building 1
 Date: 1/15/2026
 Input By: B. Nichols
 Reviewed By: F. Thauvette
 Drawing Reference:

Legend: Input by User
 No Input Required
 Reference: Fire Underwriter's Survey Guideline (2020)
 Formula Method

Building Description: 26 Storey Tower with 6 Storey Podium
 Type II - Non-combustible construction

Step		Choose		Value Used	Total Fire Flow (L/min)	
Base Fire Flow						
1	Construction Material		Multiplier		0.8	
	Coefficient related to type of construction C	Type V - Wood frame		1.5		
		Type IV - Mass Timber		Varies		
		Type III - Ordinary construction		1		
		Type II - Non-combustible construction	Yes	0.8		
		Type I - Fire resistive construction (2 hrs)		0.6		
2	Floor Area				14,000	
	A	Podium Level Footprint (m ²)	1120			
		Total Floors/Storeys (Podium)	6			
		Tower Footprint (m ²)	792			
		Total Floors/Storeys (Tower)	20			
		Protected Openings (1 hr)	No			
	A, Total Effective Floor Area (m ²)			6,064		
F	Base fire flow without reductions					
F = 220 C (A) ^{0.5}						
Reductions or Surcharges						
3	Occupancy hazard reduction or surcharge		FUS Table 3	Reduction/Surcharge	11,900	
	(1)	Non-combustible		-25%		
		Limited combustible	Yes	-15%		
		Combustible		0%		
		Free burning		15%		
		Rapid burning		25%		
			-15%			
4	Sprinkler Reduction		FUS Table 4	Reduction	-5,950	
	(2)	Adequately Designed System (NFPA 13)	Yes	-30%		
		Standard Water Supply	Yes	-10%		
		Fully Supervised System	Yes	-10%		
		Cumulative Sub-Total				-50%
		Area of Sprinklered Coverage (m²)	22,560	100%		
			-50%			
5	Exposure Surcharge per		FUS Table 6	Surcharge	2,737	
	(3)	North Side	>30m	0%		
		East Side	20.1 - 30 m	3%		
		South Side	3.1 - 10 m	16%		
		West Side	20.1 - 30 m	4%		
		Cumulative Total				23%
Results						
6	(1) + (2) + (3)	Total Required Fire Flow, rounded to nearest 1000L/min		L/min	9,000	
		(2,000 L/min < Fire Flow < 45,000 L/min)		or	L/s	150
				or	USGPM	2,378

FUS - Fire Flow Calculations



Engineers, Planners & Landscape Architects

Novatech Project #: 121302
 Project Name: 2026 Scott Street - Building 2
 Date: 1/15/2026
 Input By: B. Nichols
 Reviewed By: F. Thauvette
 Drawing Reference:

Legend: Input by User
 No Input Required
 Reference: Fire Underwriter's Survey Guideline (2020)
 Formula Method

Building Description: 36 Storey Tower with 6 Storey Podium
 Type II - Non-combustible construction

Step		Choose		Value Used	Total Fire Flow (L/min)	
Base Fire Flow						
1	Construction Material		Multiplier		0.8	
	Coefficient related to type of construction C	Type V - Wood frame		1.5		
		Type IV - Mass Timber		Varies		
		Type III - Ordinary construction		1		
		Type II - Non-combustible construction	Yes	0.8		
		Type I - Fire resistive construction (2 hrs)		0.6		
2	Floor Area				13,000	
	A	Podium Level Footprint (m ²)	1042			
		Total Floors/Storeys (Podium)	6			
		Tower Footprint (m ²)	802			
		Total Floors/Storeys (Tower)	30			
		Protected Openings (1 hr)	No			
	A, Total Effective Floor Area (m ²)			5,772		
F	Base fire flow without reductions					
F = 220 C (A) ^{0.5}						
Reductions or Surcharges						
3	Occupancy hazard reduction or surcharge		FUS Table 3	Reduction/Surcharge	11,050	
	(1)	Non-combustible		-25%		
		Limited combustible	Yes	-15%		
		Combustible		0%		
		Free burning		15%		
		Rapid burning		25%		
			-15%			
4	Sprinkler Reduction		FUS Table 4	Reduction	-5,525	
	(2)	Adequately Designed System (NFPA 13)	Yes	-30%		
		Standard Water Supply	Yes	-10%		
		Fully Supervised System	Yes	-10%		
		Cumulative Sub-Total				-50%
		Area of Sprinklered Coverage (m²)		30,312		100%
			-50%			
5	Exposure Surcharge per		FUS Table 6	Surcharge	2,542	
	(3)	North Side	>30m	0%		
		East Side	20.1 - 30 m	4%		
		South Side	10.1 - 20 m	8%		
		West Side	3.1 - 10 m	11%		
		Cumulative Total				23%
Results						
6	(1) + (2) + (3)	Total Required Fire Flow, rounded to nearest 1000L/min		L/min	8,000	
		(2,000 L/min < Fire Flow < 45,000 L/min)		or	L/s	133
				or	USGPM	2,114

FUS - Fire Flow Calculations



Engineers, Planners & Landscape Architects

Novatech Project #: 121302
 Project Name: 2026 Scott Street - Building 3
 Date: 1/15/2026
 Input By: B. Nichols
 Reviewed By: F. Thauvette
 Drawing Reference:

Legend: Input by User

No Input Required

Reference: Fire Underwriter's Survey Guideline (2020)
 Formula Method

Building Description: 18 Storey Tower with 4 Storey Podium
 Type II - Non-combustible construction

Step		Choose		Value Used	Total Fire Flow (L/min)	
Base Fire Flow						
1	Construction Material Coefficient related to type of construction C	Type V - Wood frame		1.5	0.8	
		Type IV - Mass Timber		Varies		
		Type III - Ordinary construction		1		
		Type II - Non-combustible construction	Yes	0.8		
		Type I - Fire resistive construction (2 hrs)		0.6		
2	Floor Area A	Podium Level Footprint (m ²)	1110	5,748	13,000	
		Total Floors/Storeys (Podium)	4			
		Tower Footprint (m ²)	806			
		Total Floors/Storeys (Tower)	14			
		Protected Openings (1 hr)	No			
		A, Total Effective Floor Area (m ²)				
	F	Base fire flow without reductions $F = 220 C (A)^{0.5}$				
Reductions or Surcharges						
3	Occupancy hazard reduction or surcharge (1)	FUS Table 3		Reduction/Surcharge	11,050	
		Non-combustible		-25%		
		Limited combustible	Yes	-15%		
		Combustible		0%		
		Free burning		15%		
Rapid burning		25%				
4	Sprinkler Reduction (2)	FUS Table 4		Reduction	-5,525	
		Adequately Designed System (NFPA 13)	Yes	-30%		-30%
		Standard Water Supply	Yes	-10%		-10%
		Fully Supervised System	Yes	-10%		-10%
		Cumulative Sub-Total				-50%
Area of Sprinklered Coverage (m²)	15,724	100%				
Cumulative Total			-50%			
5	Exposure Surcharge per (3)	FUS Table 6		Surcharge	3,205	
		North Side	10.1 - 20 m	8%		
		East Side	10.1 - 20 m	10%		
		South Side	>30m	0%		
		West Side	3.1 - 10 m	11%		
Cumulative Total			29%			
Results						
6	(1) + (2) + (3)	Total Required Fire Flow, rounded to nearest 1000L/min		L/min	9,000	
		(2,000 L/min < Fire Flow < 45,000 L/min)		or	L/s	150
				or	USGPM	2,378



HOBIN
ARCHITECTURE

February 5, 2026

To: Jean-Charles Renaud, MCIP/MICU, RPP/UPC Planner III (A)
110 Laurier Avenue West
Ottawa, ON
K1P 1J1

Partners

Barry J. Hobin
OAA, FRAIC, Hon. Fellow AIA
Founding Partner

Wendy Brawley
OAA, MRAIC, Associate AIA

Douglas Brooks
Arch. Tech.

Marc Thivierge
OAA, MRAIC

Reinhard Vogel
Arch. Tech.

Rheal Labelle
M. Arch.

Dan Henhoeffler
Arch. Tech.

Melanie Lamontagne
OAA, MRAIC

Patrick Bisson
OAA, OAAQ, MRAIC

Please find this letter as a formal confirmation that the drawings pertaining to the Site Plan Control Application – 2006, 2020, 2026 Scott Street & 314, 318 Athlone Avenue meet the required parameters resulting in a reduction in fire flow. Phase One of the development, comprised of one 26-storey building and a three storey below grade parking garage will be constructed to ensure:

- The development is fully sprinklered, fully supervised, and designed as per NFPA 13,
- All structural elements have a minimum 2-hour fire rating,
- The development will be comprised of noncombustible materials as per the Ontario Building Code,
- The construction coefficient will equal 0.8 for Type II Noncombustible Construction

Sincerely,

Patrick Bisson
Hobin Architecture Inc.

**Hobin Architecture
Incorporated**

63 Pamilla Street
Ottawa, Ontario
Canada K1S 3K7

t 613-238-7200

f 613-235-2005

hobinarc.com



Conceptual Water Servicing - 2006, 2020, 2026 Scott St. & 314 - 318 Athlone Ave.

Twin water services are proposed to provide redundancy, as preliminary water demand calculations indicate that the average daily demand for the proposed development is anticipated to exceed 50,000 L/day.

Proposed twin water service connections to 203mm dia. PVC municipal watermain c/w new isolation valve on existing watermain in Scott St.

Existing municipal fire hydrant to be maintained and protected.

HYDRANT ID: 362028H110
(56m+/- FROM TOWER 1,
5m+/- FROM TOWER 2,
60m+/- FROM TOWER 3)

1200mm dia. C00 Watermain

203mm dia. PVC Watermain

HYDRANT ID: 362028H057
(142m+/- FROM TOWER 1,
92m+/- FROM TOWER 2,
147m+/- FROM TOWER 3)

TOWER 2

TOWER 1

TOWER 3

HYDRANT ID: 362028H192
(70m+/- FROM TOWER 1,
115m+/- FROM TOWER 2,
194m+/- FROM TOWER 3)

HYDRANT ID: 362028H111
120m+/- FROM TOWER 1
182m+/- FROM TOWER 2
240m+/- FROM TOWER 3

Existing municipal fire hydrant to be maintained and protected.

HYDRANT ID: 362028H070
(15m+/- FROM TOWER 1,
82m+/- FROM TOWER 2,
143m+/- FROM TOWER 3)

HYDRANT ID: 362028H071
(77m+/- FROM TOWER 1,
203m+/- FROM TOWER 2,
284m+/- FROM TOWER 3)

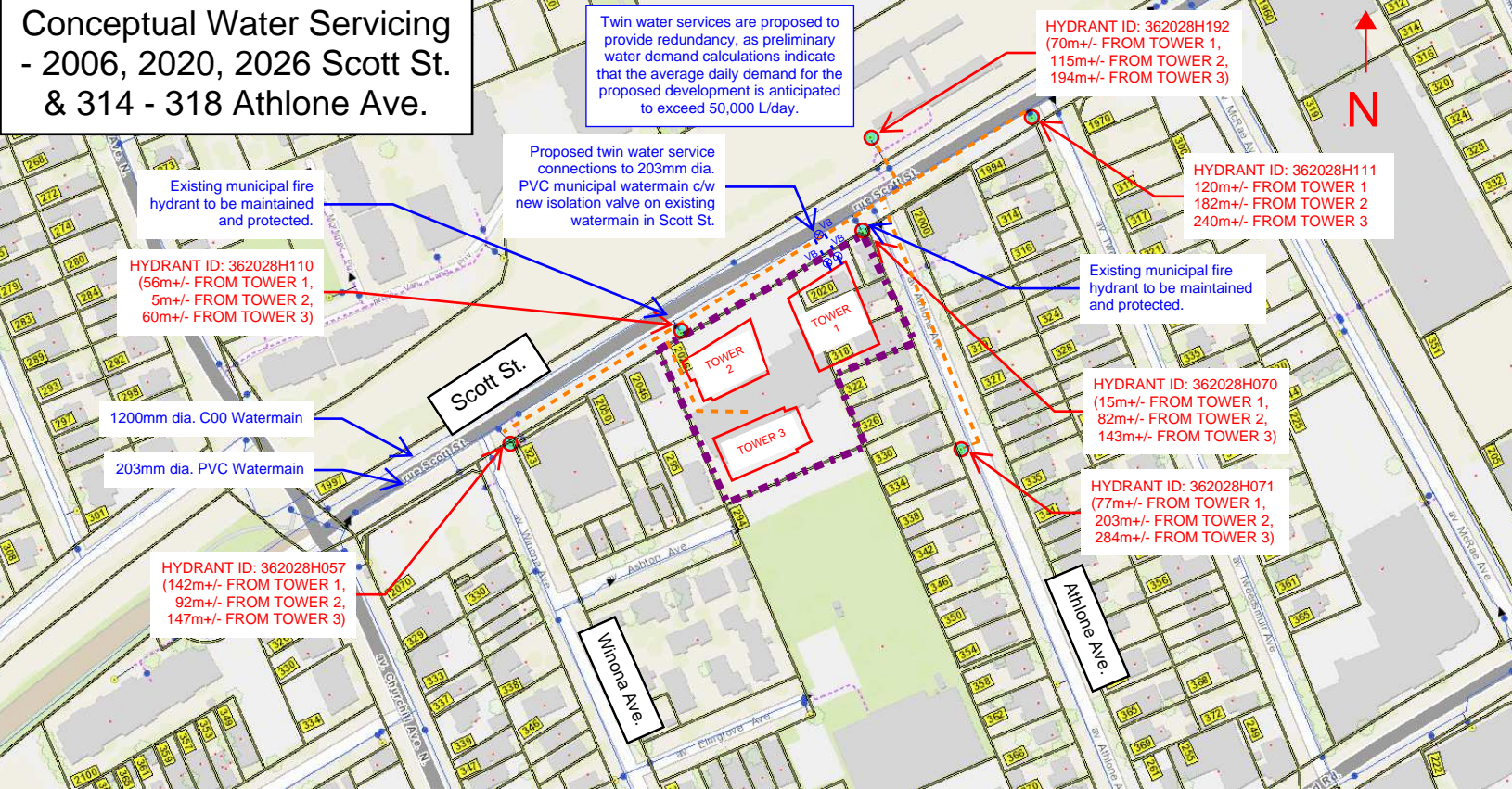

Kynan Dsa

From: Fawzi, Mohammed <mohammed.fawzi@ottawa.ca>
Sent: Tuesday, January 27, 2026 4:48 PM
To: Francois Thauvette
Cc: Wu, John; Kynan Dsa
Subject: RE: 2026 Scott Street - D07-12-23-0019 - NEW Watermain Boundary Conditions Request (121302)
Attachments: 2026 Scott Street January 2026.pdf

Hi Francois,

The following are boundary conditions, HGL, for hydraulic analysis at 2026 Scott Street (zone 1W) assumed to be dually connected to the 203mm on Scott Street. (see attached PDF for location).

Minimum HGL = 108.5 m
Maximum HGL = 114.6 m
Max Day + Fire Flow (133.33 L/s) = 104.9 m
Max Day + Fire Flow (150.00 L/s) = 103.7 m

These are for current conditions and are based on computer model simulation.

Disclaimer: The boundary condition information is based on current operation of the city water distribution system. The computer model simulation is based on the best information available at the time. The operation of the water distribution system can change on a regular basis, resulting in a variation in boundary conditions. The physical properties of watermains deteriorate over time, as such must be assumed in the absence of actual field test data. The variation in physical watermain properties can therefore alter the results of the computer model simulation. Fire Flow analysis is a reflection of available flow in the watermain; there may be additional restrictions that occur between the watermain and the hydrant that the model cannot take into account.

Best Regards,

Mohammed Fawzi, P.Eng.

Senior Project Manager (A), Infrastructure Projects

Development Review – West Branch

Planning, Development and Building Services Department (PDBS) | Direction générale des services de la planification, de l'aménagement et du bâtiment (DGSPAB)

City of Ottawa | Ville d'Ottawa

110 Laurier Avenue West | 110 Avenue Laurier Ouest

Ottawa, ON K1P 1J1

613.580.2424 ext./poste 70120, Mohammed.Fawzi@ottawa.ca

From: Fawzi, Mohammed
Sent: January 16, 2026 8:48 AM
To: Francois Thauvette <f.thauvette@novatech-eng.com>
Cc: Wu, John <John.Wu@ottawa.ca>; Kynan Dsa <k.dsa@novatech-eng.com>
Subject: RE: 2026 Scott Street - D07-12-23-0019 - NEW Watermain Boundary Conditions Request (121302)

Hi Francois,

This email is to confirm your request has been received. Results will be provided as soon as they are available.

Thank you.

Best Regards,

Mohammed Fawzi, P.Eng.

Senior Project Manager (A), Infrastructure Projects
Development Review – West Branch

Planning, Development and Building Services Department (PDBS)| Direction générale des services de la
planification, de l'aménagement et du bâtiment (DGSPAB)

City of Ottawa | Ville d'Ottawa

110 Laurier Avenue West | 110 Avenue Laurier Ouest

Ottawa, ON K1P 1J1

613.580.2424 ext./poste 70120, Mohammed.Fawzi@ottawa.ca

From: Francois Thauvette <f.thauvette@novatech-eng.com>
Sent: January 15, 2026 4:46 PM
To: Fawzi, Mohammed <mohammed.fawzi@ottawa.ca>
Cc: Wu, John <John.Wu@ottawa.ca>; Kynan Dsa <k.dsa@novatech-eng.com>
Subject: FW: 2026 Scott Street - D07-12-23-0019 - NEW Watermain Boundary Conditions Request (121302)

CAUTION: This email originated from an External Sender. Please do not click links or open attachments unless you recognize the source.

ATTENTION : Ce courriel provient d'un expéditeur externe. Ne cliquez sur aucun lien et n'ouvrez pas de pièce jointe, excepté si vous connaissez l'expéditeur.

Hi Mohammed,

We are sending you this e-mail to request updated municipal watermain boundary conditions for the proposed **3-tower** re-development of the subject site. Refer to the e-mail below and to the attachments for further details.

Regards,

François Thauvette, P. Eng., Sr. Project Manager | Land Development & Public-Sector Engineering
NOVATECH
Engineers, Planners & Landscape Architects

From: Kynan Dsa <k.dsa@novatech-eng.com>
Sent: Thursday, January 15, 2026 2:18 PM
To: Francois Thauvette <f.thauvette@novatech-eng.com>
Subject: RE: 2026 Scott Street - D07-12-23-0019 - Watermain Boundary Conditions Request (121302)

Hi François,

The configuration of the proposed multi-tower development located at 2026 Scott Street (including other adjacent properties to be merged) has been revised based on direction from the client. The revised proposal will include **three** varying-height towers above an underground parking structure instead of the previously proposed **two**-tower design.

Please request 'new' watermain boundary conditions from the City of Ottawa for twin service laterals off the existing 200mm dia. municipal watermain in Scott Street (as shown on geoOttawa). Although we do not anticipate requiring any on-site private fire hydrants (at this is time) as there are multiple existing municipal hydrants adjacent to the subject site, a private hydrant may be included in the re-design (TBD). However, the relocation of an existing municipal hydrant will be required to accommodate the proposed site access off Scott Street. The proposed redundant water connections will be located on the north side of Building 1 and will provide water for all three towers, similar to the previous (two-tower) servicing design. The anticipated water demands for the proposed three-tower development are as follows:

- Average Day Demand = 4.5 L/s
- Maximum Day Demand = 11.2 L/s
- Peak Hour Demand = 24.7 L/s
- Fire Flow Demand Range = 133-150 L/s

See attached calculation sheets for details. As indicated, the domestic demands are similar to the original design of the site, however the maximum FUS requirement has been reduced.

A multi-hydrant approach to firefighting is anticipated to be required. As indicated on the geoOttawa website, there are multiple blue bonnet municipal hydrants within 75m of the site, as well as additional blue bonnet hydrants within 150m of the subject site that could be used for firefighting purposes. See attached Boundary Conditions Request Sketch for details.

Please review and let me know if you require any additional information.

Thanks,

Kynan D'sa, B.A.Sc. (Engineering) (He/Him)

NOVATECH

Engineers, Planners & Landscape Architects
240 Michael Cowpland Drive, Suite 200, Ottawa, ON, K2M 1P6
Tel: 613.254.9643 Ext. 276 | Cell: 705.821.2278

The information contained in this email message is confidential and is for exclusive use of the addressee.

From: Wessel, Shawn <shawn.wessel@ottawa.ca>
Sent: Tuesday, March 8, 2022 9:33 AM
To: Francois Thauvette <f.thauvette@novatech-eng.com>
Cc: Steve Matthews <S.Matthews@novatech-eng.com>
Subject: RE: 2026 Scott Street - Watermain Boundary Conditions Request

Good morning, Francois

Please find conditions, as requested, below:

Concerns with Building #3 meeting required fire flow:

- Confirm 362028H057 is measured along a fire access route within their site.
- Hydrant 362028H059 will not be able to deliver the maximum fire flow and therefore this watermain may need to be upgraded unless Hydrant 362028H070 is within 150m measured from the hydrant to building along the fire access roads – Technical Bulletin 2018-02.
- Is there fire access roads within the site from Scott Street as the hydrants the consultant has identified need to be measured along these to the buildings

******The following information may be passed on to the consultant, but do NOT forward this e-mail directly.******

The following are boundary conditions, HGL, for hydraulic analysis at 2026 Scott Street (zone 1W) assumed to be connected to the 203 mm watermain on Scott Street and the 203 mm on Athlone Avenue (see attached PDF for location).

Both Connections

Minimum HGL: 108.3 m

Maximum HGL: 115.0 m

Max Day + Fire Flow (167 L/s): 101.6 m (Scott connection) and 100.5 m (Athlone connection)

Max Day + Fire Flow (183 L/s): 100.1 m (Scott connection) and 98.8 (Athlone connection)

Max Day + Fire Flow (217 L/s): 96.4 m (Scott connection) and 94.6 (Athlone connection)

These are for current conditions and are based on computer model simulation.

Disclaimer: The boundary condition information is based on current operation of the city water distribution system. The computer model simulation is based on the best information available at the time. The operation of the water distribution system can change on a regular basis, resulting in a variation in boundary conditions. The physical properties of watermains deteriorate over time, as such must be assumed in the absence of actual field test data. The variation in physical watermain properties can therefore alter the results of the computer model simulation.

If you require additional information or clarification, please do not hesitate to contact me anytime.

Thank you

Regards,

Shawn Wessel, A.Sc.T.,rcji
Project Manager - Infrastructure Approvals
Gestionnaire de projet – Approbation des demandes d’infrastructures

Development Review Central Branch | Direction de l’examen des projets d’aménagement, Centrale
Planning, Real Estate and Economic Development Department | Direction générale de la planification des biens immobiliers et du
développement économique
City of Ottawa | Ville d'Ottawa
110 Laurier Ave. W. | 110, avenue Laurier Ouest, Ottawa ON K1P 1J1
(613) 580 2424 Ext. | Poste 33017
Int. Mail Code | Code de Courrier Interne 01-14
shawn.wessel@ottawa.ca

 Please consider the environment before printing this email

Vacation Alert:

I will be out of the office February 14-18th inclusive. Please contact John Wu or Abdul Mottalib in my absence.

*****Please also note that, while my work hours may be affected by the current situation and am working from home, I still have access to email, video conferencing and telephone. Feel free to schedule video conferences and/or telephone calls, as necessary.*****

From: Francois Thauvette <f.thauvette@novatech-eng.com>
Sent: March 02, 2022 2:48 PM
To: Wessel, Shawn <shawn.wessel@ottawa.ca>
Cc: Steve Matthews <S.Matthews@novatech-eng.com>
Subject: FW: 2026 Scott Street - Watermain Boundary Conditions Request

CAUTION: This email originated from an External Sender. Please do not click links or open attachments unless you recognize the source.

ATTENTION : Ce courriel provient d’un expéditeur externe. Ne cliquez sur aucun lien et n’ouvrez pas de pièce jointe, excepté si vous connaissez l’expéditeur.

Hi Shawn,

We are sending you this message to request municipal watermain boundary conditions for the proposed residential development at 2036 Scott Street (incl. other adjacent properties to be merged). See e-mail below and attachments for details. Please note that although the attached sketch shows 2 watermain connections (one off Scott Street and the other off Athlone Avenue), it may be possible to have 2 connections to Scott Street with an isolation valve between the services. The exact configuration of the water services will have TBD at the detailed design stage, unless advised otherwise by the City’s Water Department.

Please let us know if you require any additional information.

Regards,

François Thauvette, P. Eng., Senior Project Manager | Land Development & Public Sector Engineering

NOVATECH Engineers, Planners & Landscape Architects

Please note that I am working from home. Email or MS Teams are the best ways to contact me.

240 Michael Cowpland Drive, Suite 200, Ottawa, ON, K2M 1P6 | Tel: 613.254.9643 Ext: 219 | Cell: 613.276.0310 | Fax: 613.254.5867

The information contained in this email message is confidential and is for exclusive use of the addressee.

From: Steve Matthews <S.Matthews@novatech-eng.com>

Sent: Wednesday, March 2, 2022 2:29 PM

To: Francois Thauvette <f.thauvette@novatech-eng.com>

Subject: 2026 Scott Street - Watermain Boundary Conditions Request

Hi François,

The proposed residential development located at 2026 Scott Street (in the City of Ottawa) will include three residential towers and a common underground parking garage. Refer to the attached Site Plan for details.

Please request watermain boundary conditions from the City of Ottawa for the existing 200mm dia. municipal watermain in Scott Street and the 150mm dia. municipal watermain in Athlone Avenue (as shown on geoOttawa). We do not anticipate requiring any on-site private fire hydrants as there are multiple existing municipal hydrants surrounding the property. The proposed redundant water connections will be located in the north-east corner of the building underground levels and will be serviced off the both the adjacent existing municipal watermains. The anticipated water demands for the proposed development are as follows:

- Average Day Demand = 4.4 L/s
- Maximum Day Demand = 11.1 L/s
- Peak Hour Demand = 24.4 L/s
- Maximum Fire Flow Demand = 217 L/s

See attached calculation sheets for details.

A multi-hydrant approach to firefighting is anticipated to be required. As indicated on the geoOttawa website, there are multiple blue bonnet municipal hydrants within 75m of the site, as well as additional blue bonnet municipal hydrants within 150m of the subject site that could be used for firefighting purposes. See attached Boundary Conditions Request Sketch for details.

Please review and let me know if you require any additional information.

Regards,
Steve

Stephen Matthews, B.A.(Env), Senior Design Technologist

NOVATECH Engineers, Planners & Landscape Architects

240 Michael Cowpland Drive, Suite 200, Ottawa, ON, K2M 1P6 | Tel: 613.254.9643 x 223 | Fax: 613.254.5867

The information contained in this email message is confidential and is for exclusive use of the addressee.

This e-mail originates from the City of Ottawa e-mail system. Any distribution, use or copying of this e-mail or the information it contains by other than the intended recipient(s) is unauthorized. Thank you.

Le présent courriel a été expédié par le système de courriels de la Ville d'Ottawa. Toute distribution, utilisation ou reproduction du courriel ou des renseignements qui s'y trouvent par une personne autre que son destinataire prévu est interdite. Je vous remercie de votre collaboration.

,

This e-mail originates from the City of Ottawa e-mail system. Any distribution, use or copying of this e-mail or the information it contains by other than the intended recipient(s) is unauthorized. Thank you.

Le présent courriel a été expédié par le système de courriels de la Ville d'Ottawa. Toute distribution, utilisation ou reproduction du courriel ou des renseignements qui s'y trouvent par une personne autre que son destinataire prévu est interdite. Je vous remercie de votre collaboration.

,

APPENDIX E

IDF Curves and Preliminary SWM Calculations

Ottawa Sewer Design Guidelines

APPENDIX 5-A

OTTAWA INTENSITY DURATION FREQUENCY (IDF) CURVE

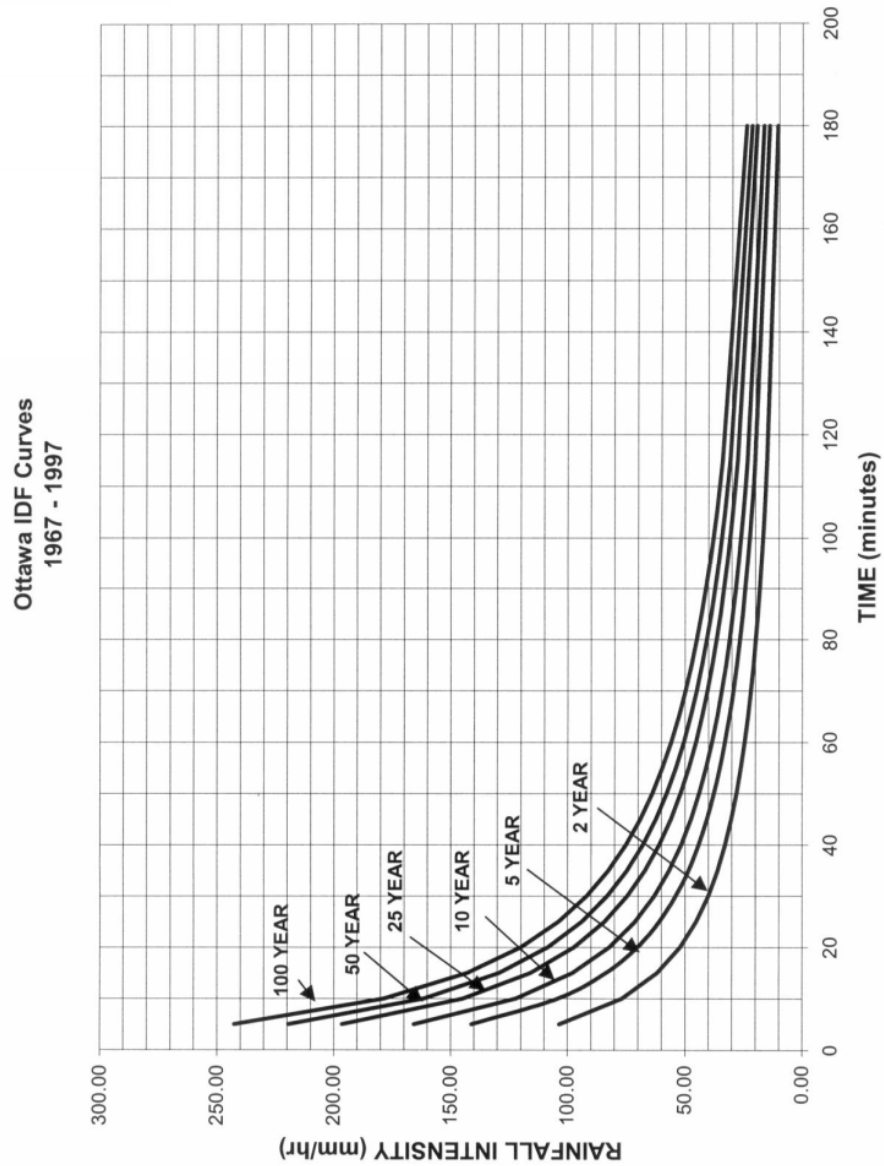

Proposed Multi-Tower Site Development 2026 Scott Street

Pre - Development Site Flows												
Description	Area (ha)	$A_{impervious}$ (ha) C=0.9	A_{gravel} (ha) C=0.6	$A_{pervious}$ (ha) C=0.2	Weighted C_{w5}	Weighted C_{w100}	2-Year Flow (L/s)	5-Year Flow (L/s)	100-Year Flow (L/s)	Allowable $C_w=0.5$ Max	Allowable Flow	
											2-year (L/s)	
Off-Site Tributary Area OS-1 (East)	0.105	0.036	0.000	0.069	0.44	0.51	9.8	13.3	26.4	0.50	-	
Off-Site Tributary Area OS-2 (South)	0.069	0.067	0.000	0.002	0.88	0.98	13.0	17.6	33.6	0.50	-	
Site to be Developed	0.659	0.628	0.000	0.031	0.87	0.96	122.0	165.6	315.7	0.50	70.4	

$T_c = 10$ mins

Post - Development Site Flows																
Area	Description	Area (ha)	A_{imp} (ha) C=0.9	$A_{planters}$ (ha) C=0.6	A_{perv} (ha) C=0.2	C_5	C_{100}	Uncontrolled Flow (L/s)			Controlled Flow (L/s)			Storage Required (m ³)		
								2-year	5-year	100-year	2-year	5-year	100-year	2-year	5-year	100-year
OS-1	Off-Site Tributary Area OS-1 (East)	0.105	0.036	0.000	0.069	0.44	0.51	9.8	13.3	26.4	-	-	-	-	-	-
A-1	Direct Runoff (North/East)	0.036	0.033	0.002	0.002	0.86	0.96	6.5	8.9	16.9	-	-	-	-	-	-
A-2	Uncontrolled Flow (East)	0.008	0.000	0.000	0.008	0.20	0.25	0.4	0.5	1.0	-	-	-	-	-	-
A-3a	Controlled Site Flow - Building 1	0.188	0.154	0.024	0.010	0.83	0.93	-	-	-	13.5	13.5	13.5	11.8	20.2	55.9
A-3b	Controlled Site Flow - Buildings 2 & 3	0.416	0.416	0.000	0.000	0.90	1.00	-	-	-	28.0	28.0	28.0	32.6	54.1	141.6
A-4	Direct Runoff (West/South)	0.012	0.012	0.000	0.000	0.90	1.00	2.3	3.1	5.9	-	-	-	-	-	-
Total Site Flows :								50.7	53.9	65.4						
$T_c = 10$ mins								19.7	16.4	5.0						
A-2 + OS-1	Uncontrolled Flow (East) + Off-Site Tributary Area (East)	0.113	0.036	0.000	0.078	0.42	0.49	10.2	13.8	27.4	-	-	-	-	-	-

Proposed Multi-Tower Residential Development Novatech Project No. 121302 REQUIRED STORAGE - 1:2 YEAR EVENT AREA OS-1 Off-Site Tributary Area OS-1 (East)					
OTTAWA IDF CURVE					
Area = 0.105 ha		Qallow = 9.8 L/s			
C = 0.44		Vol(max) = -			
Time (min)	Intensity (mm/hr)	Q (L/s)	Qnet (L/s)	Vol (m3)	
5	103.57	13.26	3.43	1.03	
10	76.81	9.83	0.00	0.00	
15	61.77	7.91	-1.93	-1.73	
20	52.03	6.66	-3.17	-3.81	
25	45.17	5.78	-4.05	-6.08	
30	40.04	5.13	-4.71	-8.47	
35	36.06	0.03	-9.80	-20.58	
40	32.86	4.21	-5.63	-13.50	
45	30.24	0.56	-9.28	-25.06	
50	28.04	3.59	-6.24	-18.73	
55	26.17	3.35	-6.48	-21.40	
60	24.56	3.14	-6.69	-24.08	
65	23.15	2.96	-6.87	-26.79	
70	21.91	2.81	-7.03	-29.52	
75	20.81	2.67	-7.17	-32.26	
80	19.83	2.54	-7.30	-35.02	
85	18.94	2.43	-7.41	-37.79	
90	18.14	2.32	-7.51	-40.56	

Proposed Multi-Tower Residential Development Novatech Project No. 121302 REQUIRED STORAGE - 1:5 YEAR EVENT AREA A-1 Off-Site Tributary Area OS-1 (East)					
OTTAWA IDF CURVE					
Area = 0.105 ha		Qallow = 13.3 L/s			
C = 0.44		Vol(max) = -			
Time (min)	Intensity (mm/hr)	Q (L/s)	Qnet (L/s)	Vol (m3)	
5	141.18	18.08	8.24	2.47	
10	104.19	13.34	3.51	2.10	
15	83.56	10.70	0.86	0.78	
20	70.25	9.00	-0.84	-1.01	
25	60.90	7.80	-2.04	-3.06	
30	53.93	6.91	-2.93	-5.27	
35	48.52	6.21	-3.62	-7.61	
40	44.18	5.66	-4.18	-10.02	
45	40.63	5.20	-4.63	-12.51	
50	37.65	4.82	-5.01	-15.04	
55	35.12	4.50	-5.34	-17.61	
60	32.94	4.22	-6.59	-33.59	
65	31.04	3.98	-5.86	-22.85	
70	29.37	3.76	-6.07	-25.51	
75	27.89	3.57	-6.26	-28.19	
80	26.56	3.40	-6.43	-30.88	
85	25.37	3.25	-6.59	-33.59	
90	24.29	3.11	-6.72	-36.31	

Proposed Multi-Tower Residential Development Novatech Project No. 121302 REQUIRED STORAGE - 1:100 YEAR EVENT AREA OS-1 Off-Site Tributary Area OS-1 (East)					
OTTAWA IDF CURVE					
Area = 0.105 ha		Qallow = 26.4 L/s			
C = 0.51		Vol(max) = -			
Time (min)	Intensity (mm/hr)	Q (L/s)	Qnet (L/s)	Vol (m3)	
5	242.70	35.83	9.47	2.84	
10	178.56	26.36	0.00	0.00	
15	142.89	21.09	-5.26	-4.74	
20	119.95	17.71	-8.65	-10.38	
25	103.85	15.33	-11.03	-16.54	
30	91.87	13.56	-12.80	-23.04	
35	82.58	12.19	-14.17	-29.75	
40	75.15	11.09	-15.27	-36.64	
45	69.05	10.19	-16.17	-43.65	
50	63.95	9.44	-16.92	-50.75	
55	59.62	8.80	-17.56	-57.94	
60	55.89	8.25	-18.11	-65.19	
65	52.65	7.77	-18.59	-72.49	
70	49.79	7.35	-19.01	-79.84	
75	47.26	6.98	-19.38	-87.22	
80	44.99	6.64	-19.72	-94.64	
85	42.95	6.34	-20.02	-102.09	
90	41.11	6.07	-20.29	-109.57	

Proposed Multi-Tower Residential Development Novatech Project No. 121302 REQUIRED STORAGE - 1:100 YR + 20% IDF Increase AREA A-1 Off-Site Tributary Area OS-1 (East)					
OTTAWA IDF CURVE					
Area = 0.105 ha		Qallow = 31.6 L/s			
C = 0.51		Vol(max) = -			
Time (min)	Intensity (mm/hr)	Q (L/s)	Qnet (L/s)	Vol (m3)	
5	291.24	42.99	16.63	4.99	
10	214.27	31.63	5.27	3.16	
15	171.47	25.31	-1.05	-0.94	
20	143.94	21.25	-5.11	-6.13	
25	124.62	18.40	-7.96	-11.94	
30	110.24	16.27	-10.09	-18.15	
35	99.09	14.63	-11.73	-24.63	
40	90.17	13.31	-13.05	-31.31	
45	82.86	12.23	-14.13	-38.14	
50	76.74	11.33	-15.03	-45.09	
55	71.55	10.56	-15.80	-52.13	
60	67.07	9.90	-16.46	-59.25	
65	63.18	9.33	-17.03	-66.43	
70	59.75	8.82	-17.54	-73.66	
75	56.71	8.37	-17.99	-80.95	
80	53.99	7.97	-18.39	-88.27	
85	51.54	7.61	-18.75	-95.62	
90	49.33	7.28	-19.08	-103.01	

Proposed Multi-Tower Residential Development Novatech Project No. 121302 REQUIRED STORAGE - 1:2 YEAR EVENT AREA OS-2 Off-Site Tributary Area OS-2 (South)					
OTTAWA IDF CURVE					
Area =	0.069	ha	Qallow =	13.0	L/s
C =	0.88		Vol(max) =	-	m ³
Time (min)	Intensity (mm/hr)	Q (L/s)	Qnet (L/s)	Vol (m ³)	
5	103.57	17.52	4.53	1.36	
10	76.81	12.99	0.00	0.00	
15	61.77	10.45	-2.54	-2.29	
20	52.03	8.80	-4.19	-5.03	
25	45.17	7.64	-5.35	-8.03	
30	40.04	6.77	-6.22	-11.19	
35	36.06	0.03	-12.96	-27.21	
40	32.86	5.56	-7.43	-17.84	
45	30.24	0.56	-12.44	-33.58	
50	28.04	4.74	-8.25	-24.74	
55	26.17	4.43	-8.56	-28.26	
60	24.56	4.15	-8.84	-31.81	
65	23.15	3.92	-9.07	-35.39	
70	21.91	3.71	-9.28	-38.99	
75	20.81	3.52	-9.47	-42.62	
80	19.83	3.35	-9.64	-46.26	
85	18.94	3.20	-9.79	-49.91	
90	18.14	3.07	-9.92	-53.58	

Proposed Multi-Tower Residential Development Novatech Project No. 121302 REQUIRED STORAGE - 1:5 YEAR EVENT AREA OS-2 Off-Site Tributary Area OS-2 (South)					
OTTAWA IDF CURVE					
Area =	0.069	ha	Qallow =	17.6	L/s
C =	0.88		Vol(max) =	-	m ³
Time (min)	Intensity (mm/hr)	Q (L/s)	Qnet (L/s)	Vol (m ³)	
5	141.18	23.88	10.89	3.27	
10	104.19	17.62	4.63	2.78	
15	83.56	14.13	1.14	1.03	
20	70.25	11.88	-1.11	-1.33	
25	60.90	10.30	-2.69	-4.04	
30	53.93	9.12	-3.87	-6.96	
35	48.52	8.21	-4.78	-10.05	
40	44.18	7.47	-5.52	-13.24	
45	40.63	6.87	-6.12	-16.52	
50	37.65	6.37	-6.62	-19.87	
55	35.12	5.94	-7.05	-23.26	
60	32.94	5.57	-8.70	-44.37	
65	31.04	5.25	-7.74	-30.19	
70	29.37	4.97	-8.02	-33.69	
75	27.89	4.72	-8.27	-37.23	
80	26.56	4.49	-8.50	-40.79	
85	25.37	4.29	-8.70	-44.37	
90	24.29	4.11	-8.88	-47.97	

Proposed Multi-Tower Residential Development Novatech Project No. 121302 REQUIRED STORAGE - 1:100 YEAR EVENT AREA OS-2 Off-Site Tributary Area OS-2 (South)					
OTTAWA IDF CURVE					
Area =	0.069	ha	Qallow =	33.6	L/s
C =	0.98		Vol(max) =	-	m ³
Time (min)	Intensity (mm/hr)	Q (L/s)	Qnet (L/s)	Vol (m ³)	
5	242.70	45.64	12.06	3.62	
10	178.56	33.58	0.00	0.00	
15	142.89	26.87	-6.71	-6.04	
20	119.95	22.56	-11.02	-13.23	
25	103.85	19.53	-14.05	-21.08	
30	91.87	17.28	-16.30	-29.35	
35	82.58	15.53	-18.05	-37.91	
40	75.15	14.13	-19.45	-46.68	
45	69.05	12.99	-20.59	-55.61	
50	63.95	12.03	-21.55	-64.66	
55	59.62	11.21	-22.37	-73.81	
60	55.89	10.51	-23.07	-83.05	
65	52.65	9.90	-23.68	-92.35	
70	49.79	9.36	-24.22	-101.71	
75	47.26	8.89	-24.69	-111.12	
80	44.99	8.46	-25.12	-120.57	
85	42.95	8.08	-25.50	-130.06	
90	41.11	7.73	-25.85	-139.59	

Proposed Multi-Tower Residential Development Novatech Project No. 121302 REQUIRED STORAGE - 1:100 YR + 20% IDF Increase AREA OS-2 Off-Site Tributary Area OS-2 (South)					
OTTAWA IDF CURVE					
Area =	0.069	ha	Qallow =	40.3	L/s
C =	0.98		Vol(max) =	-	m ³
Time (min)	Intensity (mm/hr)	Q (L/s)	Qnet (L/s)	Vol (m ³)	
5	291.24	54.77	21.19	6.36	
10	214.27	40.30	6.72	4.03	
15	171.47	32.25	-1.33	-1.20	
20	143.94	27.07	-6.51	-7.81	
25	124.62	23.44	-10.14	-15.22	
30	110.24	20.73	-12.85	-23.13	
35	99.09	18.64	-14.94	-31.38	
40	90.17	16.96	-16.62	-39.89	
45	82.86	15.58	-18.00	-48.59	
50	76.74	14.43	-19.15	-57.44	
55	71.55	13.46	-20.13	-66.41	
60	67.07	12.61	-20.97	-75.48	
65	63.18	11.88	-21.70	-84.63	
70	59.75	11.24	-22.34	-93.85	
75	56.71	10.66	-22.92	-103.12	
80	53.99	10.15	-23.43	-112.45	
85	51.54	9.69	-23.89	-121.82	
90	49.33	9.28	-24.30	-131.24	

Proposed Multi-Tower Residential Development Novatech Project No. 121302 REQUIRED STORAGE - 1:2 YEAR EVENT AREA A-1 Direct Runoff (North/East)					
OTTAWA IDF CURVE					
Area =	0.036	ha	Qallow =	6.5	L/s
C =	0.86		Vol(max) =	-	m ³
Time (min)	Intensity (mm/hr)	Q (L/s)	Qnet (L/s)	Vol (m ³)	
5	103.57	8.80	2.27	0.68	
10	76.81	6.53	0.00	0.00	
15	61.77	5.25	-1.28	-1.15	
20	52.03	4.42	-2.11	-2.53	
25	45.17	3.84	-2.69	-4.03	
30	40.04	3.40	-3.12	-5.62	
35	36.06	0.03	-6.49	-13.64	
40	32.86	2.79	-3.73	-8.96	
45	30.24	0.56	-5.97	-16.13	
50	28.04	2.38	-4.14	-12.43	
55	26.17	2.22	-4.30	-14.20	
60	24.56	2.09	-4.44	-15.99	
65	23.15	1.97	-4.56	-17.78	
70	21.91	1.86	-4.67	-19.59	
75	20.81	1.77	-4.76	-21.41	
80	19.83	1.69	-4.84	-23.24	
85	18.94	1.61	-4.92	-25.08	
90	18.14	1.54	-4.99	-26.92	

Proposed Multi-Tower Residential Development Novatech Project No. 121302 REQUIRED STORAGE - 1:5 YEAR EVENT AREA A-1 Direct Runoff (North/East)					
OTTAWA IDF CURVE					
Area =	0.036	ha	Qallow =	8.9	L/s
C =	0.86		Vol(max) =	-	m ³
				0	
Time (min)	Intensity (mm/hr)	Q (L/s)	Qnet (L/s)	Vol (m ³)	
5	141.18	12.00	5.47	1.64	
10	104.19	8.86	2.33	1.40	
15	83.56	7.10	0.57	0.52	
20	70.25	5.97	-0.56	-0.67	
25	60.90	5.18	-1.35	-2.03	
30	53.93	4.58	-1.94	-3.50	
35	48.52	4.12	-2.40	-5.05	
40	44.18	3.76	-2.77	-6.65	
45	40.63	3.45	-3.07	-8.30	
50	37.65	3.20	-3.33	-9.98	
55	35.12	2.99	-3.54	-11.69	
60	32.94	2.80	-4.37	-22.29	
65	31.04	2.64	-3.89	-15.17	
70	29.37	2.50	-4.03	-16.93	
75	27.89	2.37	-4.16	-18.71	
80	26.56	2.26	-4.27	-20.50	
85	25.37	2.16	-4.37	-22.29	
90	24.29	2.06	-4.46	-24.10	

Proposed Multi-Tower Residential Development Novatech Project No. 121302 REQUIRED STORAGE - 1:100 YEAR EVENT AREA A-1 Direct Runoff (North/East)					
OTTAWA IDF CURVE					
Area =	0.036	ha	Qallow =	16.9	L/s
C =	0.96		Vol(max) =	-	m ³
Time (min)	Intensity (mm/hr)	Q (L/s)	Qnet (L/s)	Vol (m ³)	
5	242.70	23.04	6.09	1.83	
10	178.56	16.95	0.00	0.00	
15	142.89	13.56	-3.39	-3.05	
20	119.95	11.39	-5.56	-6.68	
25	103.85	9.86	-7.09	-10.64	
30	91.87	8.72	-8.23	-14.81	
35	82.58	7.84	-9.11	-19.13	
40	75.15	7.13	-9.82	-23.56	
45	69.05	6.55	-10.39	-28.07	
50	63.95	6.07	-10.88	-32.64	
55	59.62	5.66	-11.29	-37.26	
60	55.89	5.31	-11.64	-41.92	
65	52.65	5.00	-11.95	-46.61	
70	49.79	4.73	-12.22	-51.34	
75	47.26	4.49	-12.46	-56.09	
80	44.99	4.27	-12.68	-60.86	
85	42.95	4.08	-12.87	-65.65	
90	41.11	3.90	-13.05	-70.45	

Proposed Multi-Tower Residential Development Novatech Project No. 121302 REQUIRED STORAGE - 1:100 YR + 20% IDF Increase AREA A-1 Direct Runoff (North/East)					
OTTAWA IDF CURVE					
Area =	0.036	ha	Qallow =	20.3	L/s
C =	0.96		Vol(max) =	-	m ³
Time (min)	Intensity (mm/hr)	Q (L/s)	Qnet (L/s)	Vol (m ³)	
5	291.24	27.65	10.70	3.21	
10	214.27	20.34	3.39	2.03	
15	171.47	16.28	-0.67	-0.61	
20	143.94	13.66	-3.29	-3.94	
25	124.62	11.83	-5.12	-7.68	
30	110.24	10.46	-6.48	-11.67	
35	99.09	9.41	-7.54	-15.84	
40	90.17	8.56	-8.39	-20.14	
45	82.86	7.87	-9.08	-24.53	
50	76.74	7.28	-9.66	-28.99	
55	71.55	6.79	-10.16	-33.52	
60	67.07	6.37	-10.58	-38.10	
65	63.18	6.00	-10.95	-42.71	
70	59.75	5.67	-11.28	-47.37	
75	56.71	5.38	-11.57	-52.05	
80	53.99	5.12	-11.82	-56.76	
85	51.54	4.89	-12.06	-61.49	
90	49.33	4.68	-12.27	-66.24	

Proposed Multi-Tower Residential Development Novatech Project No. 121302 REQUIRED STORAGE - 1:2 YEAR EVENT AREA A-2 Uncontrolled Flow + OS-1					
OTTAWA IDF CURVE					
Area =	0.113	ha	Qallow =	10.2	L/s
C =	0.42		Vol(max) =	1.1	m ³
Time (min)	Intensity (mm/hr)	Q (L/s)	Qnet (L/s)	Vol (m ³)	
5	103.57	13.74	3.55	1.07	
10	76.81	10.19	0.00	0.00	
15	61.77	8.20	-2.00	-1.80	
20	52.03	6.91	-3.29	-3.95	
25	45.17	5.99	-4.20	-6.30	
30	40.04	5.31	-4.88	-8.78	
35	36.06	0.03	-10.16	-21.34	
40	32.86	4.36	-5.83	-14.00	
45	30.24	0.56	-9.64	-26.02	
50	28.04	3.72	-6.47	-19.41	
55	26.17	3.47	-6.72	-22.17	
60	24.56	3.26	-6.93	-24.96	
65	23.15	3.07	-7.12	-27.77	
70	21.91	2.91	-7.28	-30.60	
75	20.81	2.76	-7.43	-33.44	
80	19.83	2.63	-7.56	-36.29	
85	18.94	2.51	-7.68	-39.16	
90	18.14	2.41	-7.78	-42.04	

Proposed Multi-Tower Residential Development Novatech Project No. 121302 REQUIRED STORAGE - 1:5 YEAR EVENT AREA A-2 Uncontrolled Flow + OS-1					
OTTAWA IDF CURVE					
Area =	0.113	ha	Qallow =	13.8	L/s
C =	0.42		Vol(max) =	2.6	m ³
Time (min)	Intensity (mm/hr)	Q (L/s)	Qnet (L/s)	Vol (m ³)	
5	141.18	18.74	8.54	2.56	
10	104.19	13.83	3.63	2.18	
15	83.56	11.09	0.90	0.81	
20	70.25	9.32	-0.87	-1.04	
25	60.90	8.08	-2.11	-3.17	
30	53.93	7.16	-3.04	-5.46	
35	48.52	6.44	-3.75	-7.88	
40	44.18	5.86	-4.33	-10.39	
45	40.63	5.39	-4.80	-12.96	
50	37.65	5.00	-5.20	-15.59	
55	35.12	4.66	-5.53	-18.25	
60	32.94	4.37	-6.83	-34.81	
65	31.04	4.12	-6.07	-23.68	
70	29.37	3.90	-6.29	-26.44	
75	27.89	3.70	-6.49	-29.21	
80	26.56	3.53	-6.67	-32.00	
85	25.37	3.37	-6.83	-34.81	
90	24.29	3.22	-6.97	-37.63	

Proposed Multi-Tower Residential Development Novatech Project No. 121302 REQUIRED STORAGE - 1:100 YEAR EVENT AREA A-2 Uncontrolled Flow + OS-1					
OTTAWA IDF CURVE					
Area =	0.113	ha	Qallow =	27.4	L/s
C =	0.49		Vol(max) =	3.0	m ³
Time (min)	Intensity (mm/hr)	Q (L/s)	Qnet (L/s)	Vol (m ³)	
5	242.70	37.24	9.84	2.95	
10	178.56	27.40	0.00	0.00	
15	142.89	21.93	-5.47	-4.93	
20	119.95	18.41	-8.99	-10.79	
25	103.85	15.93	-11.46	-17.20	
30	91.87	14.10	-13.30	-23.94	
35	82.58	12.67	-14.73	-30.93	
40	75.15	11.53	-15.87	-38.08	
45	69.05	10.60	-16.80	-45.37	
50	63.95	9.81	-17.59	-52.76	
55	59.62	9.15	-18.25	-60.23	
60	55.89	8.58	-18.82	-67.76	
65	52.65	8.08	-19.32	-75.35	
70	49.79	7.64	-19.76	-82.99	
75	47.26	7.25	-20.15	-90.67	
80	44.99	6.90	-20.50	-98.38	
85	42.95	6.59	-20.81	-106.12	
90	41.11	6.31	-21.09	-113.89	

Proposed Multi-Tower Residential Development Novatech Project No. 121302 REQUIRED STORAGE - 1:100 YR + 20% IDF Increase AREA A-2 Uncontrolled Flow + OS-1					
OTTAWA IDF CURVE					
Area =	0.113	ha	Qallow =	32.9	L/s
C =	0.49		Vol(max) =	5.2	m ³
Time (min)	Intensity (mm/hr)	Q (L/s)	Qnet (L/s)	Vol (m ³)	
5	291.24	44.69	17.29	5.19	
10	214.27	32.88	5.48	3.29	
15	171.47	26.31	-1.09	-0.98	
20	143.94	22.09	-5.31	-6.37	
25	124.62	19.12	-8.28	-12.42	
30	110.24	16.92	-10.48	-18.87	
35	99.09	15.21	-12.19	-25.61	
40	90.17	13.84	-13.56	-32.55	
45	82.86	12.71	-14.68	-39.65	
50	76.74	11.78	-15.62	-46.87	
55	71.55	10.98	-16.42	-54.19	
60	67.07	10.29	-17.11	-61.58	
65	63.18	9.69	-17.71	-69.05	
70	59.75	9.17	-18.23	-76.57	
75	56.71	8.70	-18.70	-84.14	
80	53.99	8.28	-19.11	-91.75	
85	51.54	7.91	-19.49	-99.40	
90	49.33	7.57	-19.83	-107.08	

Proposed Multi-Tower Residential Development Novatech Project No. 121302 REQUIRED STORAGE - 1:2 YEAR EVENT AREA A-3a Controlled Site Flow - Building 1					
OTTAWA IDF CURVE					
Area =	0.188	ha	Qallow =	13.5	L/s
C =	0.83		Vol(max) =	11.8	m ³
Time (min)	Intensity (mm/hr)	Q (L/s)	Qnet (L/s)	Vol (m ³)	
5	103.57	44.61	31.11	9.33	
10	76.81	33.08	19.58	11.75	
15	61.77	26.60	13.10	11.79	
20	52.03	22.41	8.91	10.69	
25	45.17	19.45	5.95	8.93	
30	40.04	17.25	3.75	6.74	
35	36.06	0.03	-13.47	-28.28	
40	32.86	14.15	0.65	1.57	
45	30.24	0.56	-12.95	-34.95	
50	28.04	12.08	-1.42	-4.27	
55	26.17	11.27	-2.23	-7.35	
60	24.56	10.58	-2.92	-10.52	
65	23.15	9.97	-3.53	-13.76	
70	21.91	9.44	-4.06	-17.06	
75	20.81	8.96	-4.54	-20.41	
80	19.83	8.54	-4.96	-23.80	
85	18.94	8.16	-5.34	-27.24	
90	18.14	7.81	-5.69	-30.70	

Proposed Multi-Tower Residential Development Novatech Project No. 121302 REQUIRED STORAGE - 1:5 YEAR EVENT AREA A-3a Controlled Site Flow - Building 1					
OTTAWA IDF CURVE					
Area =	0.188	ha	Qallow =	13.5	L/s
C =	0.83		Vol(max) =	20.2	m ³
Time (min)	Intensity (mm/hr)	Q (L/s)	Qnet (L/s)	Vol (m ³)	
5	141.18	60.81	47.31	14.19	
10	104.19	44.88	31.38	18.83	
15	83.56	35.99	22.49	20.24	
20	70.25	30.26	16.76	20.11	
25	60.90	26.23	12.73	19.09	
30	53.93	23.23	9.73	17.51	
35	48.52	20.90	7.40	15.53	
40	44.18	19.03	5.53	13.27	
45	40.63	17.50	4.00	10.80	
50	37.65	16.22	2.72	8.15	
55	35.12	15.13	1.63	5.37	
60	32.94	14.19	-2.57	-13.12	
65	31.04	13.37	-0.13	-0.50	
70	29.37	12.65	-0.85	-3.57	
75	27.89	12.01	-1.49	-6.70	
80	26.56	11.44	-2.06	-9.89	
85	25.37	10.93	-2.57	-13.12	
90	24.29	10.46	-3.04	-16.41	

Proposed Multi-Tower Residential Development Novatech Project No. 121302 REQUIRED STORAGE - 1:100 YEAR EVENT AREA A-3a Controlled Site Flow - Building 1					
OTTAWA IDF CURVE					
Area =	0.188	ha	Qallow =	13.5	L/s
C =	0.93		Vol(max) =	55.9	m ³
Time (min)	Intensity (mm/hr)	Q (L/s)	Qnet (L/s)	Vol (m ³)	
5	242.70	117.66	104.16	31.25	
10	178.56	86.56	73.06	43.84	
15	142.89	69.27	55.77	50.19	
20	119.95	58.15	44.65	53.58	
25	103.85	50.34	36.84	55.26	
30	91.87	44.54	31.04	55.86	
35	82.58	40.03	26.53	55.72	
40	75.15	36.43	22.93	55.03	
45	69.05	33.47	19.97	53.93	
50	63.95	31.00	17.50	52.51	
55	59.62	28.90	15.40	50.83	
60	55.89	27.10	13.60	48.95	
65	52.65	25.52	12.02	46.88	
70	49.79	24.14	10.64	44.67	
75	47.26	22.91	9.41	42.34	
80	44.99	21.81	8.31	39.89	
85	42.95	20.82	7.32	37.35	
90	41.11	19.93	6.43	34.72	

Proposed Multi-Tower Residential Development Novatech Project No. 121302 REQUIRED STORAGE - 1:100 YR + 20% IDF Increase AREA A-3a Controlled Site Flow - Building 1					
OTTAWA IDF CURVE					
Area =	0.188	ha	Qallow =	13.5	L/s
C =	0.93		Vol(max) =	72.5	m ³
Time (min)	Intensity (mm/hr)	Q (L/s)	Qnet (L/s)	Vol (m ³)	
5	291.24	141.19	127.69	38.31	
10	214.27	103.87	90.37	54.22	
15	171.47	83.13	69.63	62.66	
20	143.94	69.78	56.28	67.53	
25	124.62	60.41	46.91	70.37	
30	110.24	53.44	39.94	71.90	
35	99.09	48.04	34.54	72.53	
40	90.17	43.71	30.21	72.51	
45	82.86	40.17	26.67	72.01	
50	76.74	37.20	23.70	71.11	
55	71.55	34.69	21.19	69.91	
60	67.07	32.52	19.02	68.46	
65	63.18	30.63	17.13	66.79	
70	59.75	28.96	15.46	64.95	
75	56.71	27.49	13.99	62.96	
80	53.99	26.17	12.67	60.83	
85	51.54	24.99	11.49	58.59	
90	49.33	23.92	10.42	56.24	

Proposed Multi-Tower Residential Development Novatech Project No. 121302 REQUIRED STORAGE - 1:2 YEAR EVENT AREA A-3b Controlled Site Flow - Buildings 2 & 3				
OTTAWA IDF CURVE				
Area =	0.416	ha	Qallow =	28.0 L/s
C =	0.90		Vol(max) =	32.6 m ³
Time (min)	Intensity (mm/hr)	Q (L/s)	Qnet (L/s)	Vol (m ³)
5	103.57	107.71	79.71	23.91
10	76.81	79.87	51.87	31.12
15	61.77	64.23	36.23	32.61
20	52.03	54.11	26.11	31.33
25	45.17	46.97	18.97	28.46
30	40.04	41.64	13.64	24.56
35	36.06	0.03	-27.97	-58.73
40	32.86	34.18	6.18	14.82
45	30.24	0.56	-27.45	-74.10
50	28.04	29.16	1.16	3.48
55	26.17	27.22	-0.78	-2.59
60	24.56	25.54	-2.46	-8.86
65	23.15	24.08	-3.92	-15.31
70	21.91	22.79	-5.21	-21.89
75	20.81	21.64	-6.36	-28.60
80	19.83	20.62	-7.38	-35.42
85	18.94	19.70	-8.30	-42.33
90	18.14	18.87	-9.13	-49.32

Proposed Multi-Tower Residential Development Novatech Project No. 121302 REQUIRED STORAGE - 1:5 YEAR EVENT AREA A-3b Controlled Site Flow - Buildings 2 & 3				
OTTAWA IDF CURVE				
Area =	0.416	ha	Qallow =	28.0 L/s
C =	0.90		Vol(max) =	54.1 m ³
Time (min)	Intensity (mm/hr)	Q (L/s)	Qnet (L/s)	Vol (m ³)
5	141.18	146.82	118.82	35.64
10	104.19	108.35	80.35	48.21
15	83.56	86.89	58.89	53.00
20	70.25	73.06	45.06	54.07
25	60.90	63.33	35.33	52.99
30	53.93	56.08	28.08	50.55
35	48.52	50.45	22.45	47.16
40	44.18	45.95	17.95	43.08
45	40.63	42.25	14.25	38.48
50	37.65	39.16	11.16	33.47
55	35.12	36.53	8.53	28.14
60	32.94	34.26	-1.62	-8.25
65	31.04	32.28	4.28	16.70
70	29.37	30.54	2.54	10.69
75	27.89	29.00	1.00	4.51
80	26.56	27.62	-0.38	-1.81
85	25.37	26.38	-1.62	-8.25
90	24.29	25.26	-2.74	-14.81

Proposed Multi-Tower Residential Development Novatech Project No. 121302 REQUIRED STORAGE - 1:100 YEAR EVENT AREA A-3b Controlled Site Flow - Buildings 2 & 3				
OTTAWA IDF CURVE				
Area =	0.416	ha	Qallow =	28.0 L/s
C =	1.00		Vol(max) =	141.6 m ³
Time (min)	Intensity (mm/hr)	Q (L/s)	Qnet (L/s)	Vol (m ³)
5	242.70	280.44	252.44	75.73
10	178.56	206.32	178.32	106.99
15	142.89	165.11	137.11	123.40
20	119.95	138.60	110.60	132.72
25	103.85	119.99	91.99	137.99
30	91.87	106.15	78.15	140.67
35	82.58	95.42	67.42	141.58
40	75.15	86.83	58.83	141.19
45	69.05	79.79	51.79	139.82
50	63.95	73.90	45.90	137.69
55	59.62	68.89	40.89	134.95
60	55.89	64.59	36.59	131.71
65	52.65	60.83	32.83	128.04
70	49.79	57.53	29.53	124.03
75	47.26	54.60	26.60	119.71
80	44.99	51.99	23.99	115.13
85	42.95	49.63	21.63	110.33
90	41.11	47.50	19.50	105.32

Proposed Multi-Tower Residential Development Novatech Project No. 121302 REQUIRED STORAGE - 1:100 YR + 20% IDF Increase AREA A-3b Controlled Site Flow - Buildings 2 & 3				
OTTAWA IDF CURVE				
Area =	0.416	ha	Qallow =	28.0 L/s
C =	1.00		Vol(max) =	182.9 m ³
Time (min)	Intensity (mm/hr)	Q (L/s)	Qnet (L/s)	Vol (m ³)
5	291.24	336.53	308.53	92.56
10	214.27	247.59	219.59	131.75
15	171.47	198.13	170.13	153.12
20	143.94	166.32	138.32	165.98
25	124.62	143.99	115.99	173.99
30	110.24	127.38	99.38	178.89
35	99.09	114.50	86.50	181.65
40	90.17	104.19	76.19	182.87
45	82.86	95.74	67.74	182.91
50	76.74	88.68	60.68	182.03
55	71.55	82.67	54.67	180.42
60	67.07	77.50	49.50	178.21
65	63.18	73.00	45.00	175.49
70	59.75	69.04	41.04	172.36
75	56.71	65.52	37.52	168.85
80	53.99	62.38	34.38	165.04
85	51.54	59.56	31.56	160.95
90	49.33	57.00	29.00	156.62

Proposed Multi-Tower Residential Development Novatech Project No. 121302 REQUIRED STORAGE - 1:2 YEAR EVENT AREA A-4 Direct Runoff (West/South)					
OTTAWA IDF CURVE					
Area =	0.012	ha	Qallow =	2.3	L/s
C =	0.90		Vol(max) =	-	m ³
Time (min)	Intensity (mm/hr)	Q (L/s)	Qnet (L/s)	Vol (m ³)	
5	103.57	3.08	0.79	0.24	
10	76.81	2.28	0.00	0.00	
15	61.77	1.83	-0.45	-0.40	
20	52.03	1.55	-0.74	-0.88	
25	45.17	1.34	-0.94	-1.41	
30	40.04	1.19	-1.09	-1.97	
35	36.06	0.03	-2.25	-4.72	
40	32.86	0.98	-1.30	-3.13	
45	30.24	0.56	-1.73	-4.66	
50	28.04	0.83	-1.45	-4.34	
55	26.17	0.78	-1.50	-4.96	
60	24.56	0.73	-1.55	-5.59	
65	23.15	0.69	-1.59	-6.21	
70	21.91	0.65	-1.63	-6.85	
75	20.81	0.62	-1.66	-7.48	
80	19.83	0.59	-1.69	-8.12	
85	18.94	0.56	-1.72	-8.76	
90	18.14	0.54	-1.74	-9.41	

Proposed Multi-Tower Residential Development Novatech Project No. 121302 REQUIRED STORAGE - 1:5 YEAR EVENT AREA A-4 Direct Runoff (West/South)					
OTTAWA IDF CURVE					
Area =	0.012	ha	Qallow =	3.1	L/s
C =	0.90		Vol(max) =	-	m ³
Time (min)	Intensity (mm/hr)	Q (L/s)	Qnet (L/s)	Vol (m ³)	
5	141.18	4.19	1.91	0.57	
10	104.19	3.09	0.81	0.49	
15	83.56	2.48	0.20	0.18	
20	70.25	2.09	-0.19	-0.23	
25	60.90	1.81	-0.47	-0.71	
30	53.93	1.60	-0.68	-1.22	
35	48.52	1.44	-0.84	-1.76	
40	44.18	1.31	-0.97	-2.33	
45	40.63	1.21	-1.07	-2.90	
50	37.65	1.12	-1.16	-3.49	
55	35.12	1.04	-1.24	-4.09	
60	32.94	0.98	-1.53	-7.79	
65	31.04	0.92	-1.36	-5.30	
70	29.37	0.87	-1.41	-5.92	
75	27.89	0.83	-1.45	-6.54	
80	26.56	0.79	-1.49	-7.16	
85	25.37	0.75	-1.53	-7.79	
90	24.29	0.72	-1.56	-8.42	

Proposed Multi-Tower Residential Development Novatech Project No. 121302 REQUIRED STORAGE - 1:100 YEAR EVENT AREA A-4 Direct Runoff (West/South)					
OTTAWA IDF CURVE					
Area =	0.012	ha	Qallow =	5.9	L/s
C =	1.00		Vol(max) =	-	m ³
Time (min)	Intensity (mm/hr)	Q (L/s)	Qnet (L/s)	Vol (m ³)	
5	242.70	8.01	2.12	0.64	
10	178.56	5.89	0.00	0.00	
15	142.89	4.72	-1.18	-1.06	
20	119.95	3.96	-1.93	-2.32	
25	103.85	3.43	-2.47	-3.70	
30	91.87	3.03	-2.86	-5.15	
35	82.58	2.72	-3.17	-6.65	
40	75.15	2.48	-3.41	-8.19	
45	69.05	2.28	-3.61	-9.76	
50	63.95	2.11	-3.78	-11.35	
55	59.62	1.97	-3.92	-12.95	
60	55.89	1.84	-4.05	-14.57	
65	52.65	1.74	-4.15	-16.20	
70	49.79	1.64	-4.25	-17.85	
75	47.26	1.56	-4.33	-19.50	
80	44.99	1.48	-4.41	-21.16	
85	42.95	1.42	-4.47	-22.82	
90	41.11	1.36	-4.54	-24.49	

Proposed Multi-Tower Residential Development Novatech Project No. 121302 REQUIRED STORAGE - 1:100 YR + 20% IDF Increase AREA A-4 Direct Runoff (West/South)					
OTTAWA IDF CURVE					
Area =	0.012	ha	Qallow =	7.1	L/s
C =	1.00		Vol(max) =	-	m ³
Time (min)	Intensity (mm/hr)	Q (L/s)	Qnet (L/s)	Vol (m ³)	
5	291.24	9.61	3.72	1.12	
10	214.27	7.07	1.18	0.71	
15	171.47	5.66	-0.23	-0.21	
20	143.94	4.75	-1.14	-1.37	
25	124.62	4.11	-1.78	-2.67	
30	110.24	3.64	-2.25	-4.06	
35	99.09	3.27	-2.62	-5.51	
40	90.17	2.98	-2.92	-7.00	
45	82.86	2.73	-3.16	-8.53	
50	76.74	2.53	-3.36	-10.08	
55	71.55	2.36	-3.53	-11.65	
60	67.07	2.21	-3.68	-13.24	
65	63.18	2.08	-3.81	-14.85	
70	59.75	1.97	-3.92	-16.47	
75	56.71	1.87	-4.02	-18.09	
80	53.99	1.78	-4.11	-19.73	
85	51.54	1.70	-4.19	-21.38	
90	49.33	1.63	-4.26	-23.03	

APPENDIX F
City As-Built Drawings

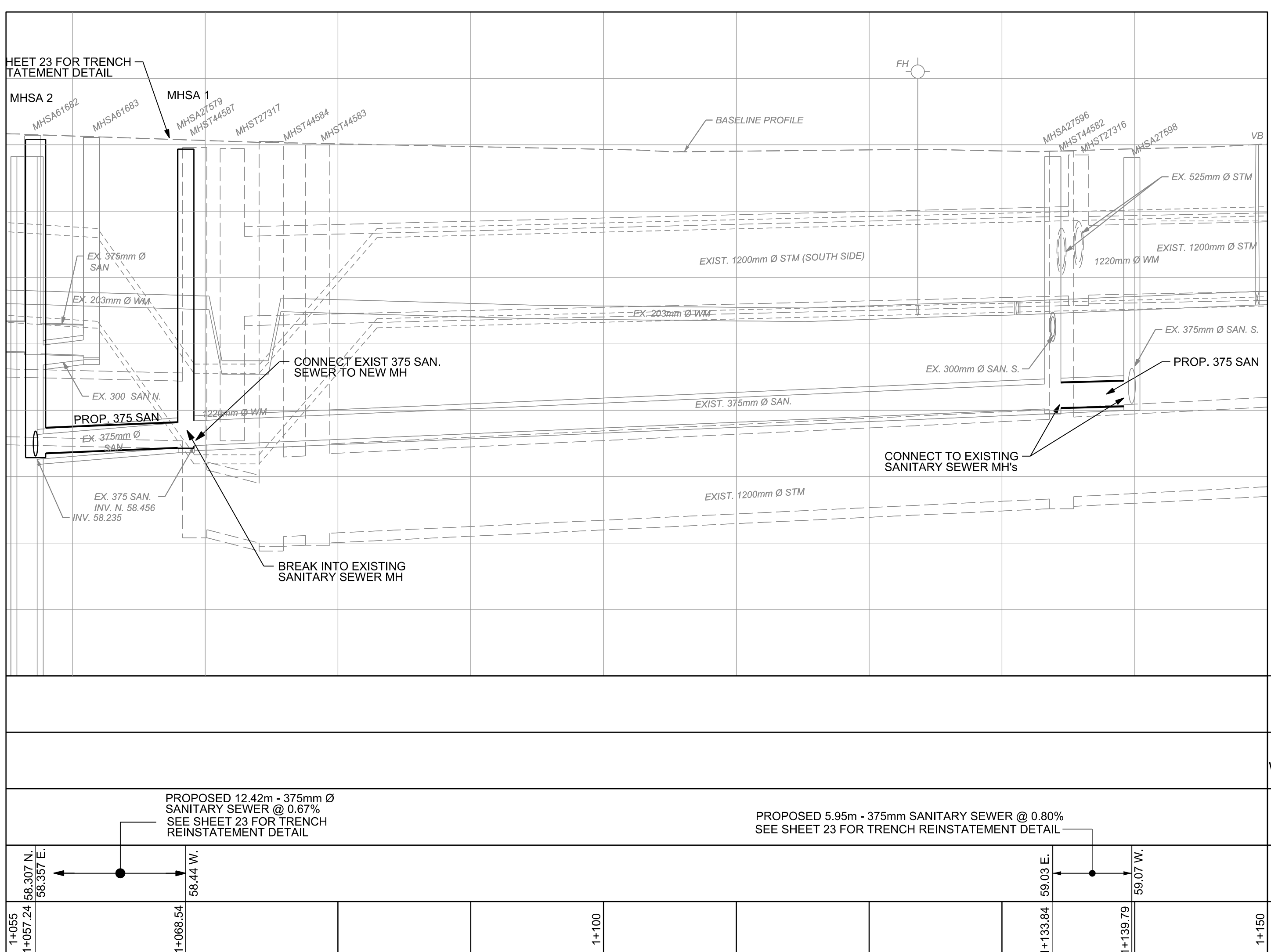
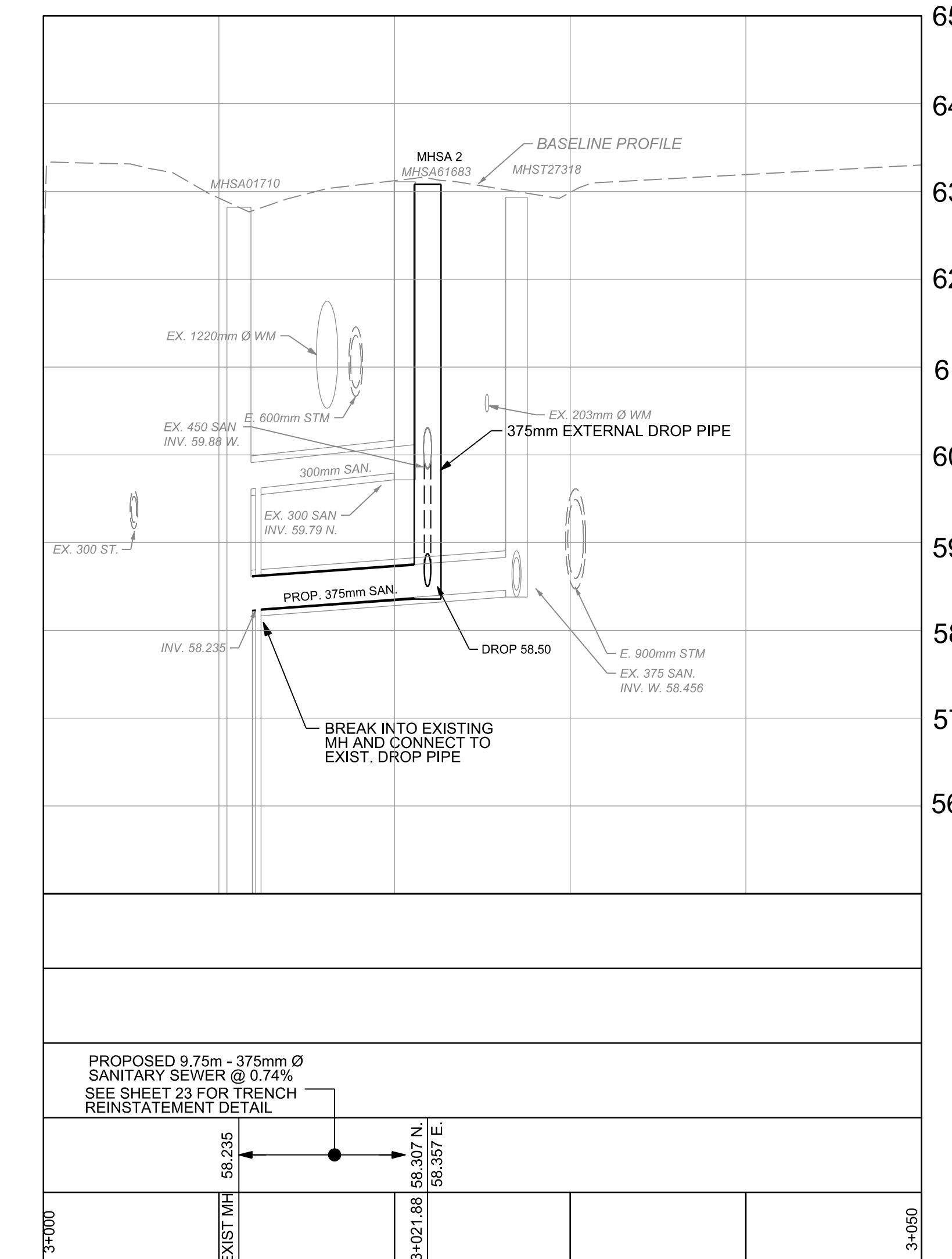
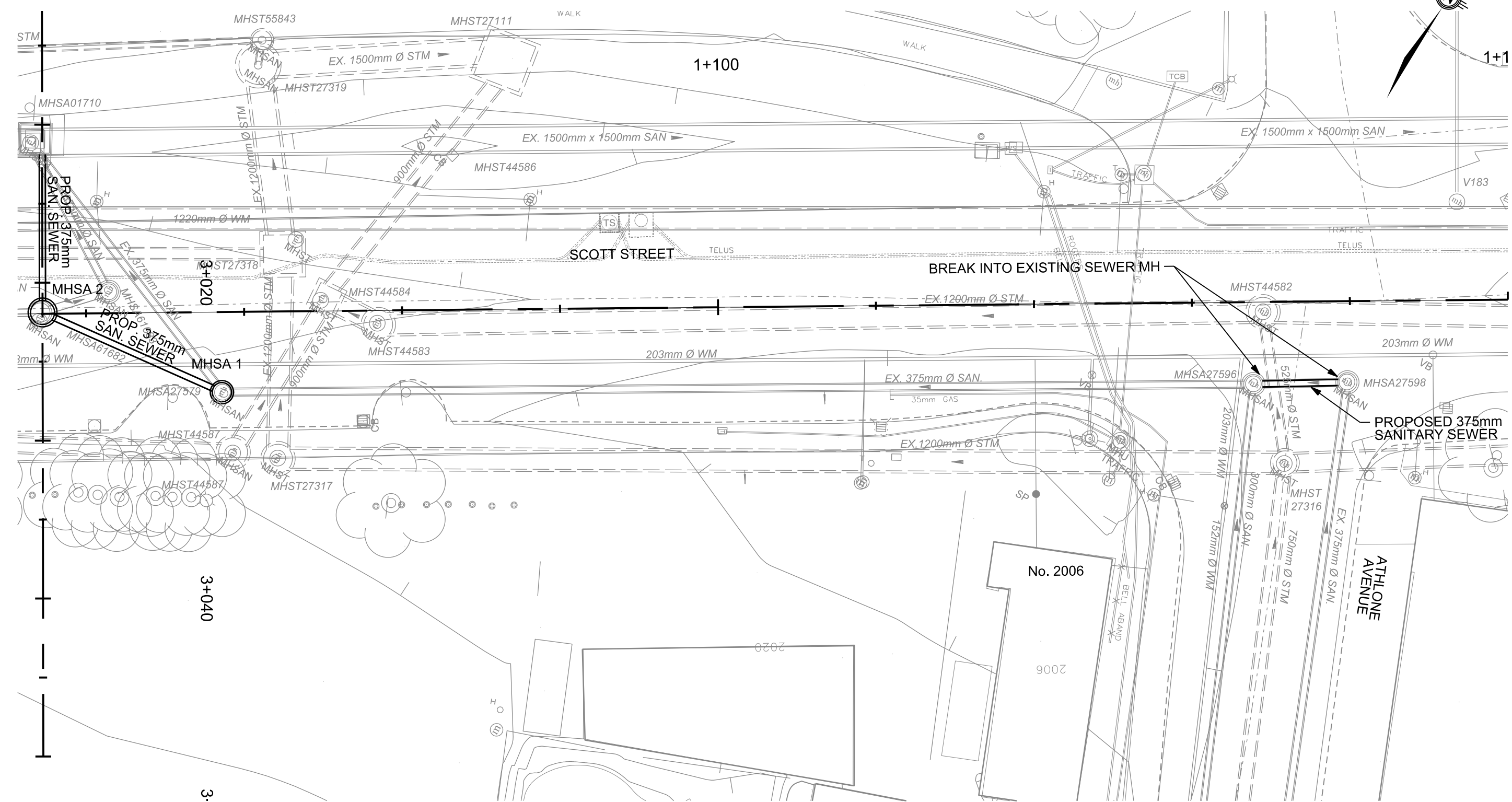
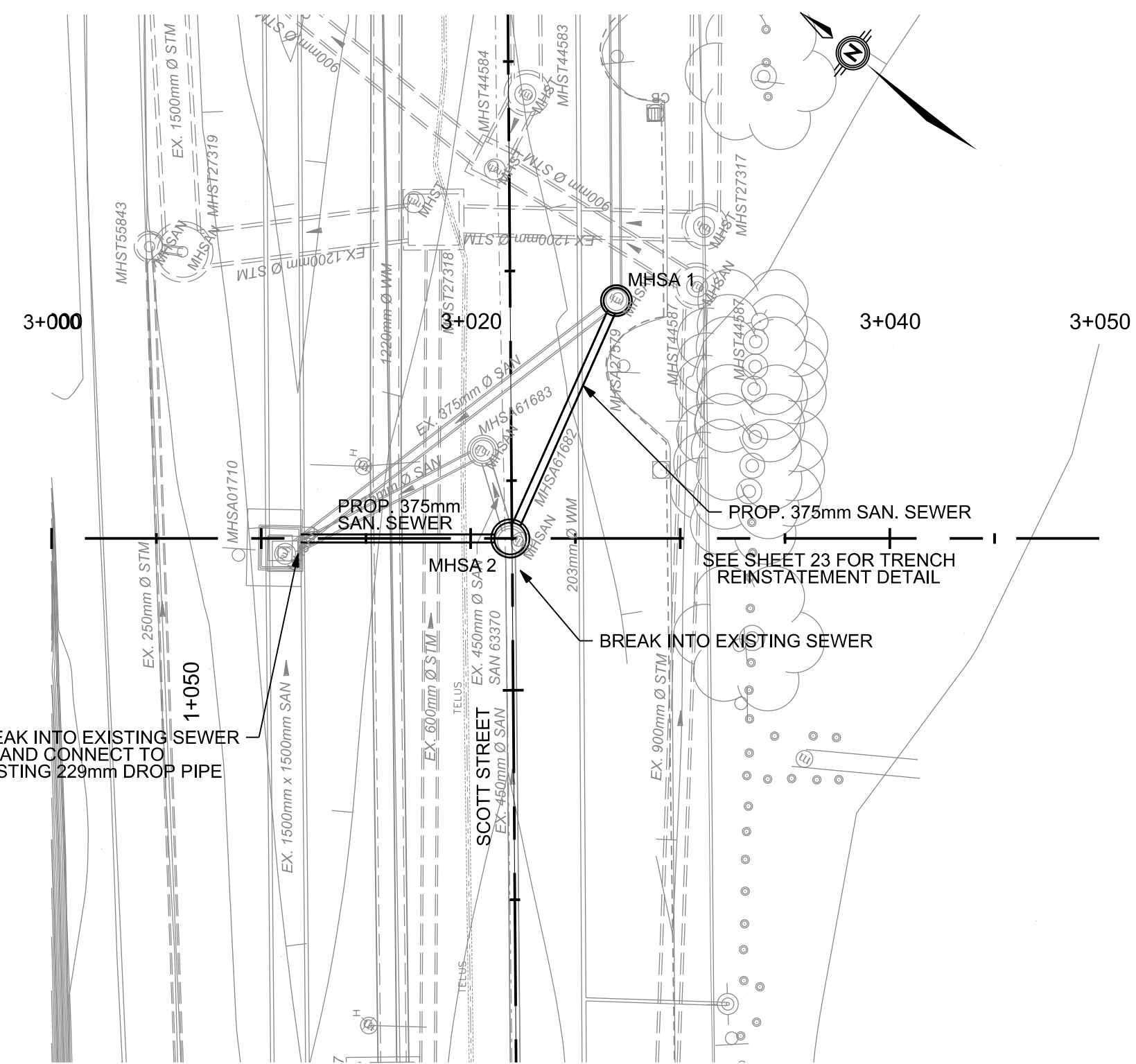

SCOTT STREET SEWER AND WATERMAIN REHABILITATION

SEWER REHABILITATION
MHA01710 TO MHA27579
MHA27596 TO MHA27598

Contract No. CP-000362		Dwg. No. 010	
Sheet 10 of 47			
Asset No.		Asset Group	
CARINA DUCLOS, P.Eng. Acting Director		P. CHAMNEY, P.Eng. Project Manager	

R. J. WESSE
14/07/2020
PROVINCE OF ONTARIO

K. P. McCAMBLEY
14/07/2020
PROVINCE OF ONTARIO

NOTE: The location of utilities is approximate only, the exact location should be determined by consulting the municipal authorities and utility companies concerned. The contractor shall prove the location of utilities and shall be responsible for adequate protection from damage.

No.	Description	By	Date (dd/mm/yy)
1	ISSUED FOR CONSTRUCTION	RT	14/07/20

CONTRACTOR IS TO ASSUME THAT EACH MUNICIPAL ADDRESS IS SERVICED BY INDIVIDUAL UTILITY SERVICES, SUCH AS HYDRO, GAS, BELL/ROGERS.

SANITARY MAINTENANCE HOLE DATA						
NO.	STATION	OFFSET	COVER	STRUCTURE	T/GRATE	ELEVATION LOW/INV.
MHA 1	1+068.54	5.07 RT	S24/S25	OPSD 701.010	62.93	58.44
MHA 2	1+057.24	0.00	S24/S25	OPSD 701.011	63.15	58.307

- OFFSETS ARE FROM CONTROL LINE TO CENTRE OF STRUCTURE
- SLF DENOTES SELF LEVEL FRAME

<p>PROPOSED 9.75m - 375mm Ø SANITARY SEWER @ 0.74% SEE SHEET 23 FOR TRENCH REINSTATEMENT DETAIL</p>	<p>PROPOSED 12.42m - 375mm Ø SANITARY SEWER @ 0.67% SEE SHEET 23 FOR TRENCH REINSTATEMENT DETAIL</p>
<p>PROPOSED 5.95m - 375mm SANITARY SEWER @ 0.80% SEE SHEET 23 FOR TRENCH REINSTATEMENT DETAIL</p>	

<p>PROPOSED 9.75m - 375mm Ø SANITARY SEWER @ 0.74% SEE SHEET 23 FOR TRENCH REINSTATEMENT DETAIL</p>	<p>PROPOSED 12.42m - 375mm Ø SANITARY SEWER @ 0.67% SEE SHEET 23 FOR TRENCH REINSTATEMENT DETAIL</p>
<p>PROPOSED 5.95m - 375mm SANITARY SEWER @ 0.80% SEE SHEET 23 FOR TRENCH REINSTATEMENT DETAIL</p>	

<p>PROPOSED 9.75m - 375mm Ø SANITARY SEWER @ 0.74% SEE SHEET 23 FOR TRENCH REINSTATEMENT DETAIL</p>	<p>PROPOSED 12.42m - 375mm Ø SANITARY SEWER @ 0.67% SEE SHEET 23 FOR TRENCH REINSTATEMENT DETAIL</p>
<p>PROPOSED 5.95m - 375mm SANITARY SEWER @ 0.80% SEE SHEET 23 FOR TRENCH REINSTATEMENT DETAIL</p>	

<p>PROPOSED 9.75m - 375mm Ø SANITARY SEWER @ 0.74% SEE SHEET 23 FOR TRENCH REINSTATEMENT DETAIL</p>	<p>PROPOSED 12.42m - 375mm Ø SANITARY SEWER @ 0.67% SEE SHEET 23 FOR TRENCH REINSTATEMENT DETAIL</p>
<p>PROPOSED 5.95m - 375mm SANITARY SEWER @ 0.80% SEE SHEET 23 FOR TRENCH REINSTATEMENT DETAIL</p>	

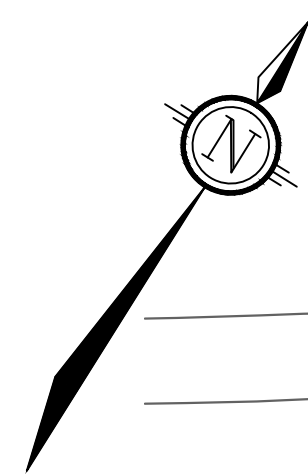

MATCHLINE STA 12+150
SEE DWG. ISB08-5000-018

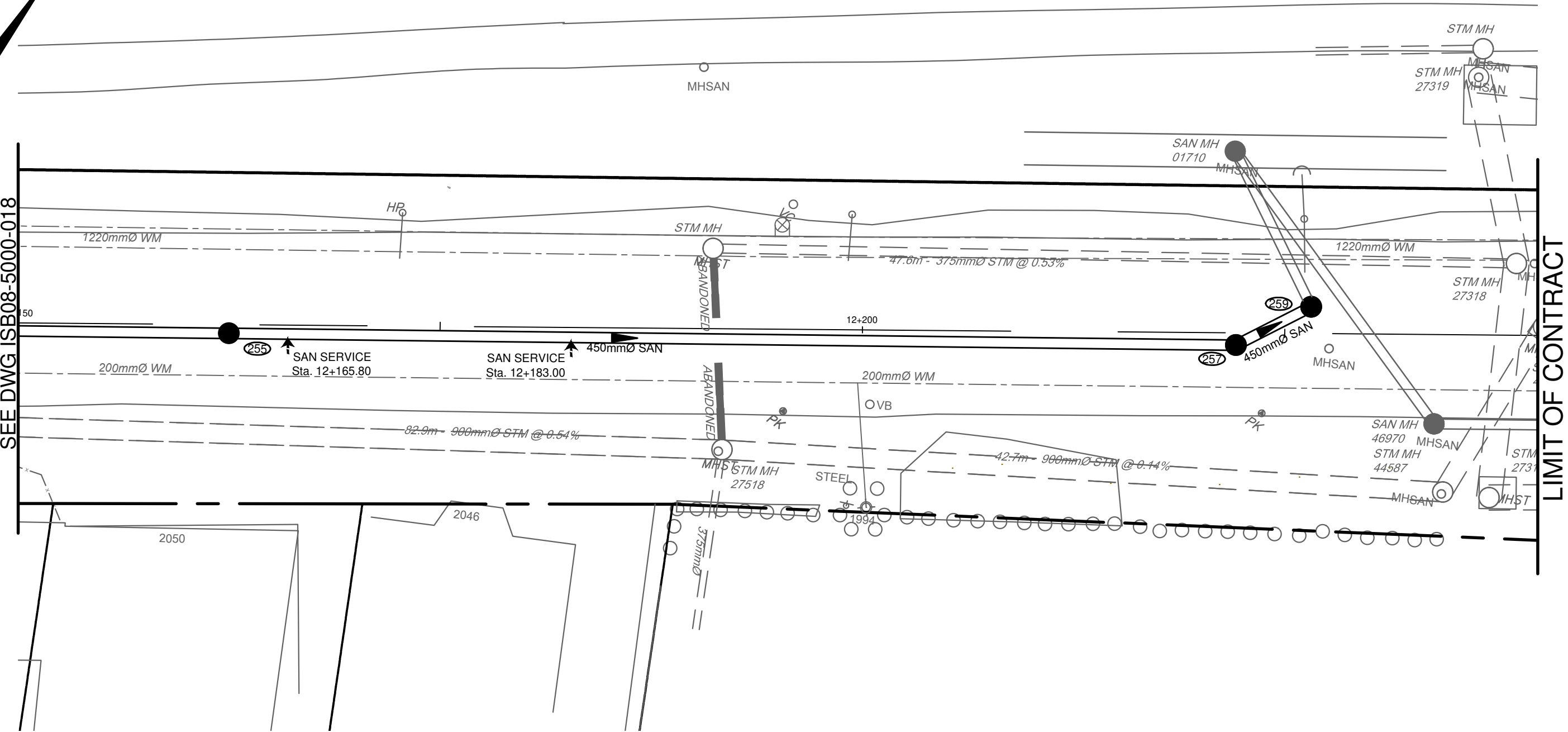

SCOTT STREET

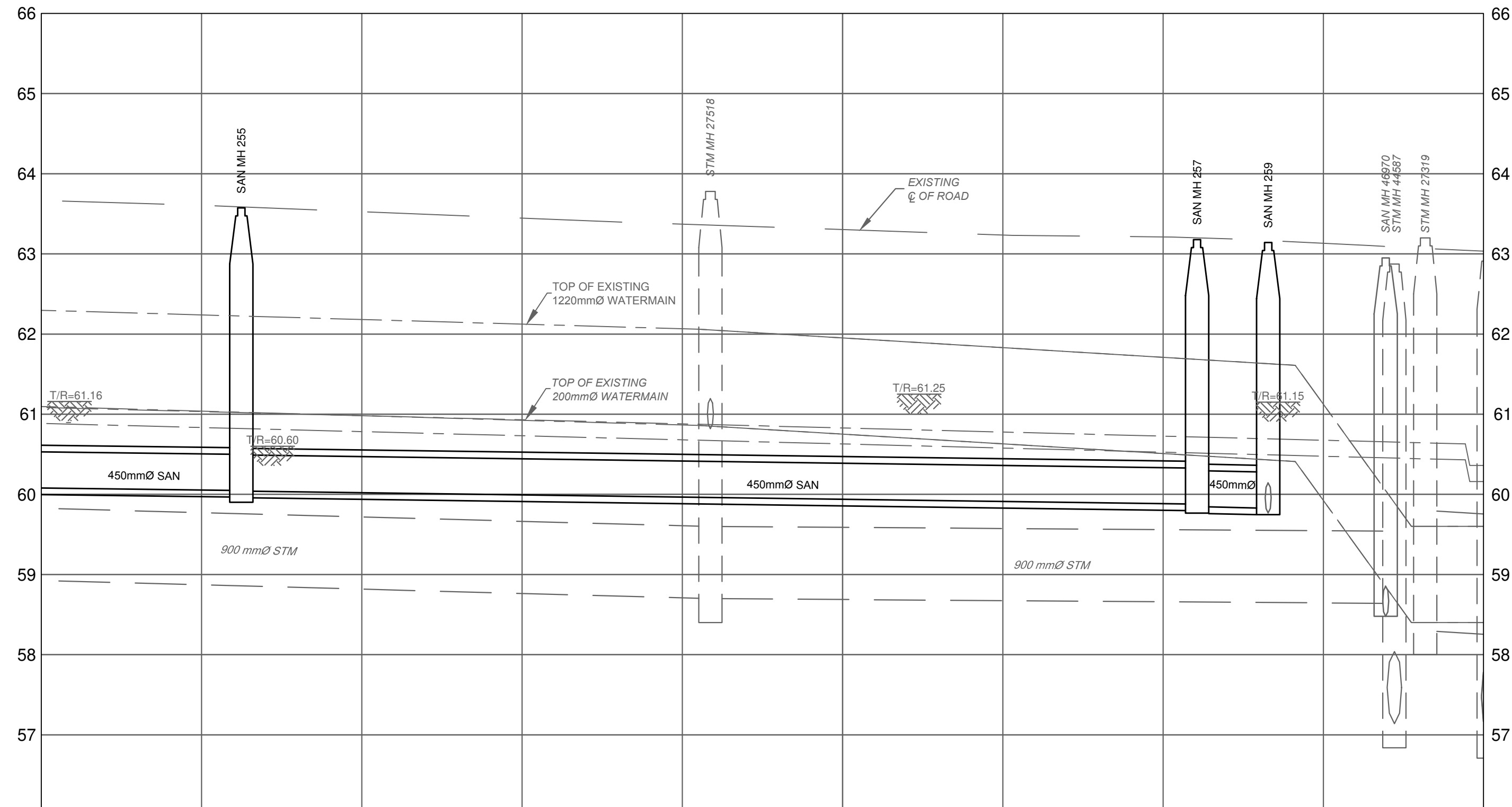

PROPOSED ELEVATION	
TOP OF WM ELEVATION	
STORM SEWER INVERTS	<p>82.91m - 900mm STM @ 0.54%</p> <p>59.82 CONC. CL 140-D 5.00m - 450mm SAN @ 0.40%</p> <p>42.74m - 900mm STM @ 0.14%</p>
SANITARY SEWER INVERTS	<p>57.55 CONC. CL 140-D 60.05m - 450mm SAN @ 0.25% 0.24%</p> <p>59.82 CONC. CL 140-D 57.17m - 450mm SAN @ 0.26% 0.27%</p>
CHAINAGE	<p>12+160</p> <p>12+165.51</p> <p>12+168.04</p> <p>12+170</p> <p>12+180</p> <p>12+190</p> <p>12+191.75 STM MH</p> <p>12+200</p> <p>12+210</p> <p>12+220</p> <p>12+222.12 SAN MH</p> <p>12+226.56 SAN MH</p> <p>12+227.85 SAN MH</p> <p>12+230</p> <p>12+234.44 STM MH</p> <p>12+240</p>

**CHURCHILL AVENUE
REHABILITATION
SCOTT STREET TO BYRON AVENUE**

**SCOTT
PLAN AND PROFILE
12+150 TO 12+240**

Contract No. ISB08-5000 Dwg. No. 019
Sheet 19 of 55

Asset No. _____
Asset Group: ISB

Des: NTO Chk'd: ERD
Dwn: RCH Chk'd: DHI
Utility Circ. No.: _____
Const. Inspector: _____

Scale: HORIZONTAL 1:10
VERTICAL 1:2

NOTE:
The location of utilities is approximate only, the exact location should be determined by consulting the municipal authorities and utility companies concerned. The contractor shall prove the location of utilities and shall be responsible for adequate protection from damage.

NOVATECH

No.	Description	By	Date
1.	ISSUED FOR PRELIMINARY DESIGN CIRCULATION	ERD	07/10/09
2.	ISSUED FOR MOE APPROVAL	ERD	07/24/09
3.	ISSUED FOR TENDER	ERD	11/06/09
4.	ISSUED FOR DESIGN CIRCULATION	ERD	11/06/09
5.	ISSUED FOR CONSTRUCTION	ERD	03/09/10
6.	AS-BUILT	ERD	04/12/12

NO.	STATION	OFFSET	COVER	STRUCTURE	ELEVATION	
					T/GRATE	LOW INV.
SAN MH-255	12+164.56	0.52 RT	*S24	OPSD 701 010	63.55	59.98
SAN MH-257	12+222.12	0.72 RT	*S24	OPSD 701 010	63.18	59.85
SAN MH-259	12+226.56	1.58 LT	*S24	OPSD 701 010	63.14	59.74

* DOWNSTREAM ELEVATIONS SHOWN ARE AT THE OVERTOP OF THE STORM SEWER (MIN. GRADE 1% FOR ALL STORM SEWER CONNECTIONS)

SEWER	FROM	TO	DIA.	LENGTH	TYPE	INVERT ELEVATIONS	
						UP STR.	DOWN STR.
SAN 253B	SAN 255	450	60.00	59.62	CONC. CL 140-D	60.14	59.98
SAN 255	SAN 257	450	59.74	59.85	CONC. CL 140-D	59.85	59.88
SAN 257	SAN 259	450	59.85	59.74	CONC. CL 140-D	59.85	59.83

OFFSETS ARE FROM CONTROL LINE TO CENTRE OF STRUCTURE
STATIONS AND T/GRATE ELEVATIONS ARE FROM THE CENTRE OF STRUCTURE
* FRAME TO BE SELF-LEVELING BY MUELLER AJ745 OR BIBBY C54M

- Notes**
- ADDITIONAL BOREHOLE INFORMATION FROM:
RMOC-200mmØ WATERMAIN "AS-BUILT" DRAWINGS - WINONA AVE TO CLIFTON AVE (1996)

APPENDIX G
Engineering Drawings

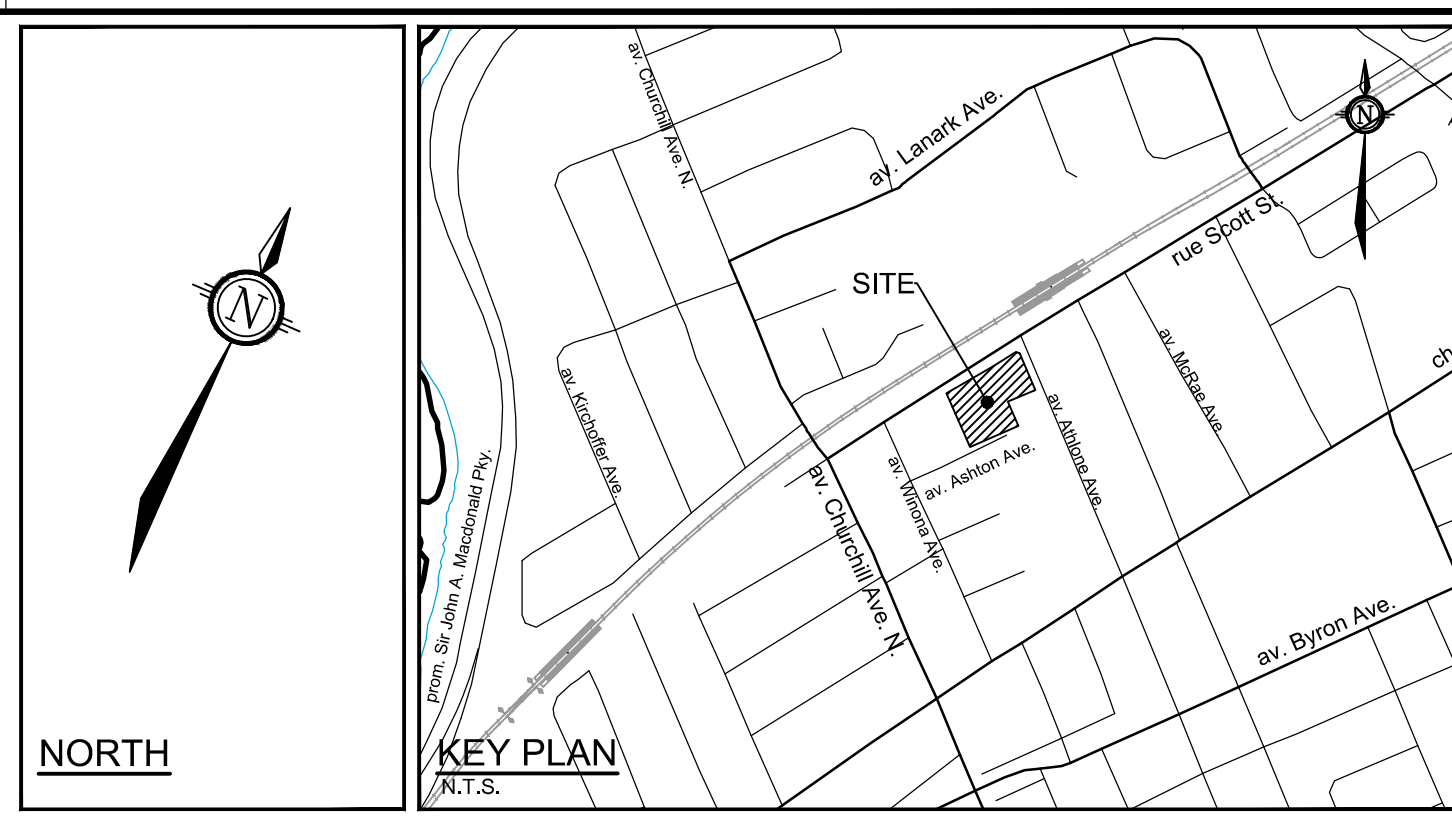
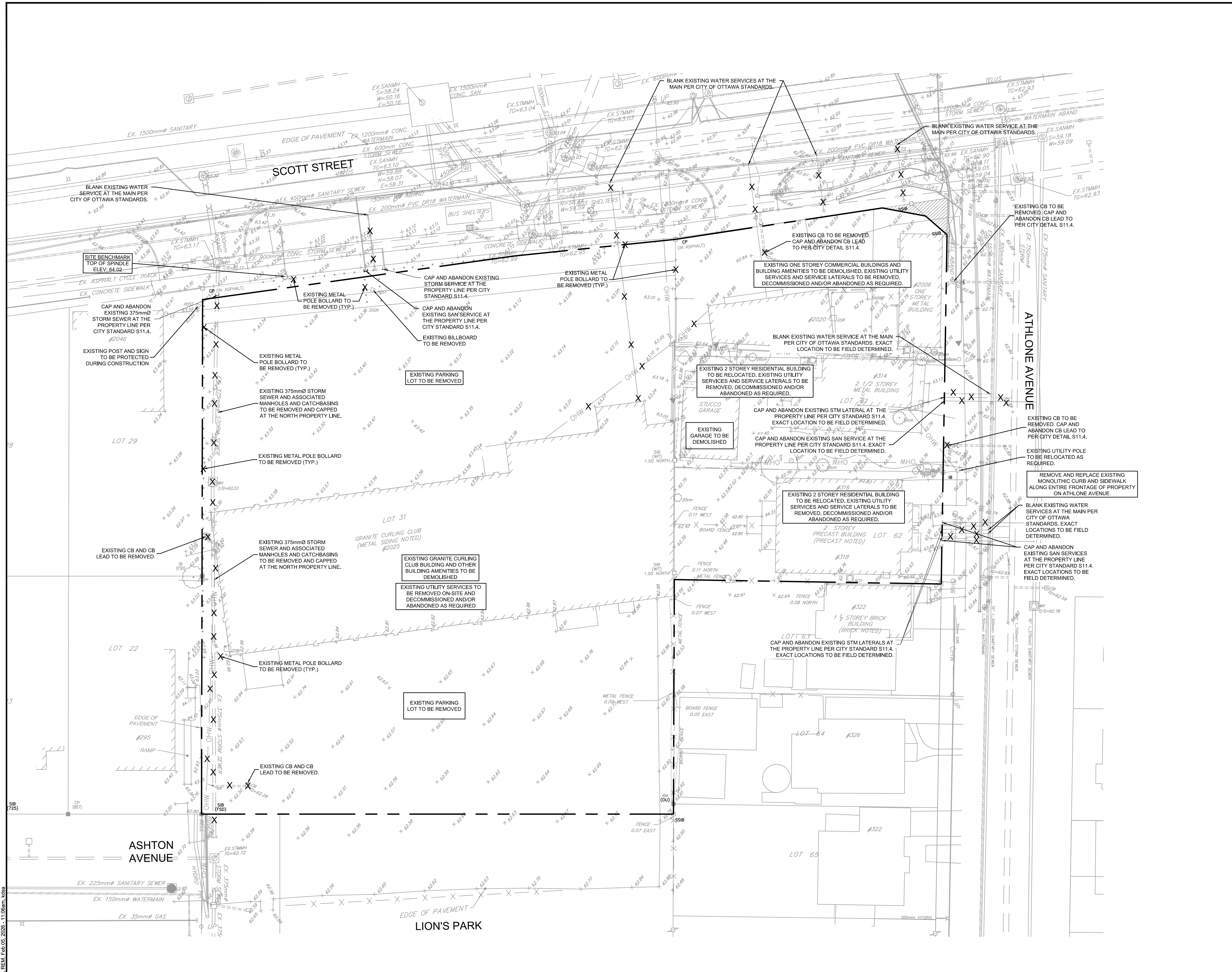

LEGEND

- X REMOVALS
- EXISTING CONCRETE CURB
- EXISTING VALVE & VALVE BOX
- EXISTING SERVICE POST
- EXISTING HYDRANT
- EXISTING CATCHBASIN
- EXISTING CATCHBASIN/H
- EXISTING UTILITY POLE
- EXISTING TREES / VEGETATION

GENERAL NOTES:

- COORDINATE AND SCHEDULE ALL WORK WITH OTHER TRADES AND CONTRACTORS.
- DETERMINE THE EXACT LOCATION, SIZE, MATERIAL AND ELEVATION OF ALL EXISTING UTILITIES PRIOR TO COMMENCING CONSTRUCTION. PROTECT AND ASSUME RESPONSIBILITY FOR ALL EXISTING UTILITIES WHETHER OR NOT SHOWN ON THIS DRAWING.
- ALL ELEVATIONS ARE GEODETIC.

BENCHMARK NOTES:

- ELEVATIONS SHOWN ARE GEODETIC AND ARE REFERRED TO THE CGVD28 GEODETIC DATUM. DERIVED ARE DERIVED FROM A SITE BENCHMARK AS SHOWN ON P6 HAVING AN ELEVATION OF 64.02.
- IT IS THE RESPONSIBILITY OF THE USER OF THIS INFORMATION TO VERIFY THAT THE JOB BENCHMARK HAS NOT BEEN ALTERED OR DISTURBED AND THAT ITS RELATIVE ELEVATION AND DESCRIPTION AGREES WITH THE INFORMATION SHOWN ON THIS DRAWING.
- BENCHMARK WAS PROVIDED ON PLAN OF SURVEY OF PART OF LOT 60 AND ALL OF LOTS 61 & 62, REGISTERED PLAN 263 AND PART OF LOT 31 CONCESSION 1 (OTTAWA FRONT), SURVEYED BY STANTEC GEOMATICS LTD.

NOTE: THE POSITION OF ALL POLE LINES, CONDUITS, WATERMANS, SEWERS AND OTHER UNDERGROUND AND OVERGROUND UTILITIES AND STRUCTURES IS NOT NECESSARILY SHOWN ON THE CONTRACT DRAWINGS, AND WHERE SHOWN, THE ACCURACY OF THE POSITION OF SUCH UTILITIES AND STRUCTURES IS NOT GUARANTEED. BEFORE STARTING WORK, DETERMINE THE EXACT LOCATION OF ALL SUCH UTILITIES AND STRUCTURES AND ASSUME ALL LIABILITY FOR DAMAGE TO THEM.

OWNER INFORMATION
 HOPPNER HOLDINGS INC.
 1818 BRADLEY SIDE ROAD,
 CARP, ONTARIO K0A 1L0
 KEN HOPPNER
 PHONE: 613-831-5490
 khoppner@morleyhoppner.com

No.	REVISION	DATE	BY
7.	REISSUED FOR ZBLA AND SPC APPLICATIONS	FEB 4/26	FST
6.	REVISED PER CITY COMMENTS	SEPT 4/24	FST
5.	REVISED PER CITY COMMENTS	JUN 27/24	FST
4.	REVISED PER CITY COMMENTS	APR 16/24	FST
3.	REVISED PER CITY COMMENTS	MAR 9/24	FST
2.	REVISED PER CITY COMMENTS	OCT 16/23	FST
1.	ISSUED FOR SPC APPLICATION	FEB 22/23	FST

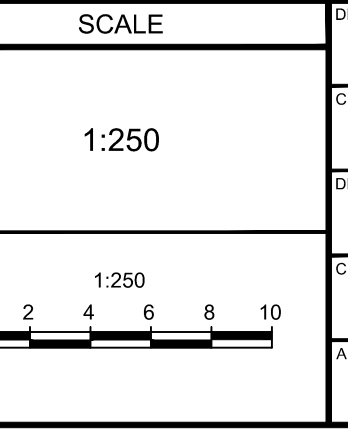

DESIGN	CV/KD
CHECKED	FST
DRAWN	CV/KD
CHECKED	FST
APPROVED	FST

FOR REVIEW ONLY

NOVATECH
 Engineers, Planners & Landscape Architects
 Suite 200, 240 Michael Cowpland Drive
 Ottawa, Ontario, Canada K2M 1P6
 Telephone: (613) 254-9643
 Facsimile: (613) 254-5867
 Website: www.novatech-eng.com

LOCATION CITY OF OTTAWA 2026 SCOTT STREET	PROJECT No. 121302
DRAWING NAME EXISTING CONDITIONS AND REMOVALS PLAN	REV # 7
	DRAWING No. 121302-REM

D07-12-23-0019

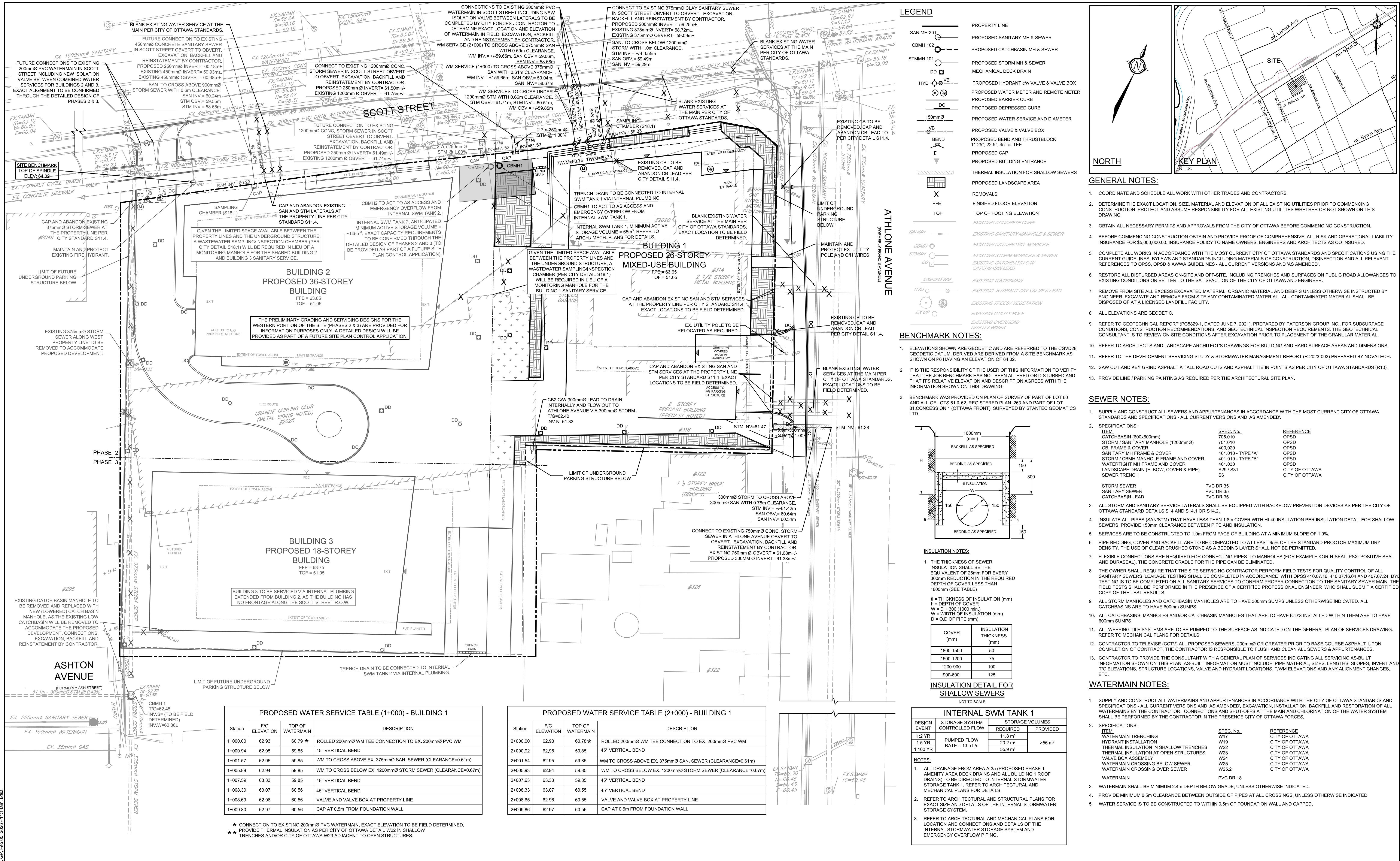

GENERAL NOTES:

- COORDINATE AND SCHEDULE ALL WORK WITH OTHER TRADES AND CONTRACTORS.
- DETERMINE THE EXACT LOCATION, SIZE, MATERIAL AND ELEVATION OF ALL EXISTING UTILITIES PRIOR TO COMMENCING CONSTRUCTION. PROTECT AND ASSUME RESPONSIBILITY FOR ALL EXISTING UTILITIES WHETHER OR NOT SHOWN ON THIS DRAWING.
- OBTAIN ALL NECESSARY PERMITS AND APPROVALS FROM THE CITY OF OTTAWA BEFORE COMMENCING CONSTRUCTION.
- BEFORE COMMENCING CONSTRUCTION OBTAIN AND PROVIDE PROOF OF COMPREHENSIVE, ALL RISK AND OPERATIONAL LIABILITY INSURANCE FOR \$5,000,000.00. INSURANCE POLICY TO NAME OWNERS, ENGINEERS AND ARCHITECTS AS CO-INSURED.
- COMPLETE ALL WORKS IN ACCORDANCE WITH THE MOST CURRENT CITY OF OTTAWA STANDARDS AND SPECIFICATIONS USING THE CURRENT GUIDELINES, BYLAWS AND STANDARDS INCLUDING MATERIALS OF CONSTRUCTION, DISINFECTION AND ALL RELEVANT REFERENCES TO OPSS, OPSD & AWWA GUIDELINES - ALL CURRENT VERSIONS AND 'AS AMENDED'.
- RESTORE ALL DISTURBED AREAS ON-SITE AND OFF-SITE, INCLUDING TRENCHES AND SURFACES ON PUBLIC ROAD ALLOWANCES TO EXISTING CONDITIONS OR BETTER TO THE SATISFACTION OF THE CITY OF OTTAWA AND ENGINEER.
- REMOVE FROM SITE ALL EXCAVATED MATERIAL, ORGANIC MATERIAL AND DEBRIS UNLESS OTHERWISE INSTRUCTED BY ENGINEER. EXCAVATE AND REMOVE FROM SITE ANY CONTAMINATED MATERIAL. ALL CONTAMINATED MATERIAL SHALL BE DISPOSED OF AT A LICENSED LANDFILL FACILITY.
- ALL ELEVATIONS ARE GEODETIC.
- REFER TO GEOTECHNICAL REPORT (PC5829-1, DATED JUNE 7, 2021), PREPARED BY PATERSON GROUP INC. FOR SUBSURFACE CONDITIONS, CONSTRUCTION RECOMMENDATIONS, AND GEOTECHNICAL INSPECTION REQUIREMENTS, THE GEOTECHNICAL CONSULTANT IS TO REVIEW ON-SITE CONDITIONS AFTER EXCAVATION PRIOR TO PLACEMENT OF THE GRANULAR MATERIAL.
- REFER TO ARCHITECTS AND LANDSCAPE ARCHITECTS DRAWINGS FOR BUILDING AND HARD SURFACE AREAS AND DIMENSIONS.
- REFER TO THE DEVELOPMENT SERVICING STUDY & STORMWATER MANAGEMENT REPORT (R-2023-003) PREPARED BY NOVATECH.
- REFER TO THE DEVELOPMENT SERVICING STUDY & STORMWATER MANAGEMENT REPORT (R-2023-003) PREPARED BY NOVATECH.
- REFER TO ARCHITECTS AND LANDSCAPE ARCHITECTS DRAWINGS FOR BUILDING AND HARD SURFACE AREAS AND DIMENSIONS.
- REFER TO THE DEVELOPMENT SERVICING STUDY & STORMWATER MANAGEMENT REPORT (R-2023-003) PREPARED BY NOVATECH.
- REFER TO ARCHITECTS AND LANDSCAPE ARCHITECTS DRAWINGS FOR BUILDING AND HARD SURFACE AREAS AND DIMENSIONS.

SEWER NOTES:

- SUPPLY AND CONSTRUCT ALL SEWERS AND APPURTENANCES IN ACCORDANCE WITH THE MOST CURRENT CITY OF OTTAWA STANDARDS AND SPECIFICATIONS - ALL CURRENT VERSIONS AND 'AS AMENDED'.
- SPECIFICATIONS:

ITEM	SPEC. No.	REFERENCE
CATCHBASIN (600x600mm)	705.010	OPSD
STORM / SANITARY MANHOLE (1200mm)	701.010	OPSD
CB, FRAME & COVER	400.020	OPSD
SANITARY MH FRAME & COVER	401.010 - TYPE "A"	OPSD
STORM / CBMH MANHOLE FRAME AND COVER	401.010 - TYPE "B"	OPSD
WATERTIGHT MH FRAME AND COVER	401.030	OPSD
LANDSCAPE DRAIN (ELBOW, COVER & PIPE)	S29 / S31	CITY OF OTTAWA
SEWER TRENCH	S6	CITY OF OTTAWA
STORM SEWER	PVC DR 35	
SANITARY SEWER	PVC DR 35	
CATCHBASIN LEAD	PVC DR 35	
- ALL STORM AND SANITARY SERVICE LATERALS SHALL BE EQUIPPED WITH BACKFLOW PREVENTION DEVICES AS PER THE CITY OF OTTAWA STANDARD DETAILS S14 AND S14.1 OR S14.2.
- INSULATE ALL PIPES (SAN/STM) THAT HAVE LESS THAN 1.8m COVER WITH HI-40 INSULATION PER INSULATION DETAIL FOR SHALLOW SEWERS, PROVIDE 150mm CLEARANCE BETWEEN PIPE AND INSULATION.
- SERVICES ARE TO BE CONSTRUCTED TO 1.0m FROM FACE OF BUILDING AT A MINIMUM SLOPE OF 1.0%.
- PIPE BEDDING, COVER AND BACKFILL ARE TO BE COMPACTED TO AT LEAST 95% OF THE STANDARD PROCTOR MAXIMUM DRY DENSITY. THE USE OF CLEAR CRUSHED STONE AS A BEDDING LAYER SHALL NOT BE PERMITTED.
- FLEXIBLE CONNECTIONS ARE REQUIRED FOR CONNECTING PIPES TO MANHOLES (FOR EXAMPLE KOR-N-SEAL, PSX- POSITIVE SEAL AND DURASEAL). THE CONCRETE CRADLE FOR THE PIPE CAN BE ELIMINATED.
- THE OWNER SHALL REQUIRE THAT THE SITE SERVICING CONTRACTOR PERFORM FIELD TESTS FOR QUALITY CONTROL OF ALL SANITARY SEWERS. LEAKAGE TESTING SHALL BE COMPLETED IN ACCORDANCE WITH OPSS 410.07.16, 410.07.16.04 AND 407.07.24. DYE TESTING IS TO BE COMPLETED ON ALL SANITARY SERVICES TO CONFIRM PROPER CONNECTION TO THE SANITARY SEWER MAIN. THE FIELD TESTS SHALL BE PERFORMED IN THE PRESENCE OF A CERTIFIED PROFESSIONAL ENGINEER WHO SHALL SUBMIT A CERTIFIED COPY OF THE TEST RESULTS.
- ALL STORM MANHOLES AND CATCHBASIN MANHOLES ARE TO HAVE 300mm SLUMPS UNLESS OTHERWISE INDICATED. ALL CATCHBASINS ARE TO HAVE 600mm SLUMPS.
- ALL CATCHBASINS, MANHOLES AND/OR CATCHBASIN MANHOLES THAT ARE TO HAVE ICDS INSTALLED WITH THEM ARE TO HAVE 600mm SLUMPS.
- ALL WEPPING TILE SYSTEMS ARE TO BE PUMPED TO THE SURFACE AS INDICATED ON THE GENERAL PLAN OF SERVICES DRAWING. REFER TO MECHANICAL PLANS FOR DETAILS.
- CONTRACTOR TO TELETYPE (CCTV) ALL PROPOSED SEWERS, 200mm OR GREATER PRIOR TO BASE COURSE ASPHALT. UPON COMPLETION OF CONTRACT, THE CONTRACTOR IS RESPONSIBLE TO FLUSH AND CLEAN ALL SEWERS & APPURTENANCES.
- CONTRACTOR TO PROVIDE THE CONSULTANT WITH A GENERAL PLAN OF SERVICES INDICATING ALL SERVICING AS-BUILT INFORMATION SHOWN ON THIS PLAN. AS-BUILT INFORMATION MUST INCLUDE PIPE MATERIAL, SIZES, LENGTHS, SLOPES, INVERT AND TIE ELEVATIONS, STRUCTURE LOCATIONS, VALVE AND HYDRANT LOCATIONS, TWM ELEVATIONS AND ANY ALIGNMENT CHANGES, ETC.

WATERMAIN NOTES:

- SUPPLY AND CONSTRUCT ALL WATERMANS AND APPURTENANCES IN ACCORDANCE WITH THE CITY OF OTTAWA STANDARDS AND SPECIFICATIONS - ALL CURRENT VERSIONS AND 'AS AMENDED', EXCAVATION, INSTALLATION, BACKFILL AND RESTORATION OF ALL WATERMANS BY THE CONTRACTOR. CONNECTIONS AND SHUT-OFFS AT THE MAIN AND CHLORINATION OF THE WATER SYSTEM SHALL BE PERFORMED BY THE CONTRACTOR IN THE PRESENCE OF THE CITY OF OTTAWA FORCES.
- SPECIFICATIONS:

ITEM	SPEC. No.	REFERENCE
WATERMAIN TRENCHING	W17	CITY OF OTTAWA
HYDRANT INSTALLATION	W19	CITY OF OTTAWA
THERMAL INSULATION IN SHALLOW TRENCHES	W22	CITY OF OTTAWA
THERMAL INSULATION AT OPEN STRUCTURES	W23	CITY OF OTTAWA
VALVE BOX ASSEMBLY	W24	CITY OF OTTAWA
WATERMAIN CROSSINGS BELOW SEWER	W25	CITY OF OTTAWA
WATERMAIN CROSSING OVER SEWER	W25.2	CITY OF OTTAWA
WATERMAIN	PVC DR 18	
- WATERMAIN SHALL BE MINIMUM 2.4m DEPTH BELOW GRADE, UNLESS OTHERWISE INDICATED.
- PROVIDE MINIMUM 0.5m CLEARANCE BETWEEN OUTSIDE OF PIPES AT ALL CROSSINGS, UNLESS OTHERWISE INDICATED.
- WATER SERVICE IS TO BE CONSTRUCTED TO WITHIN 0.5m OF FOUNDATION WALL AND CAPPED.

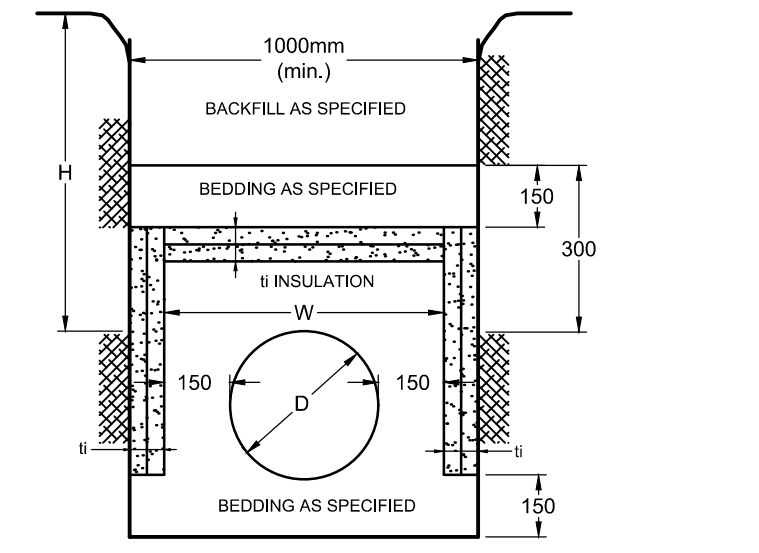

INSULATION NOTES:

- THE THICKNESS OF SEWER INSULATION SHALL BE THE EQUIVALENT OF 25mm FOR EVERY 300mm REDUCTION IN THE REQUIRED DEPTH OF COVER LESS THAN 1800mm (SEE TABLE)
- | h = DEPTH OF COVER (mm) | W = WIDTH OF INSULATION (mm) | D = O.D OF PIPE (mm) |
|-------------------------|------------------------------|----------------------|
| 1800-1500 | 50 | |
| 1500-1200 | 75 | |
| 1200-900 | 100 | |
| 900-600 | 125 | |

INTERNAL SWM TANK 1

DESIGN EVENT	STORAGE SYSTEM CONTROLLED FLOW	STORAGE VOLUMES REQUIRED	STORAGE VOLUMES PROVIDED
1.2 YR	PUMPED FLOW	11.8 m³	>56 m³
1.5 YR	RATE = 13.5 L/s	20.2 m³	
1:100 YR		55.9 m³	

NOTES:

- ALL DRAINAGE FROM AREA A-3a (PROPOSED PHASE 1 AMENITY AREA DECK DRAINS AND ALL BUILDING 1 ROOF DRAINS) IS TO BE DIRECTED TO INTERNAL STORMWATER STORAGE TANK 1. REFER TO ARCHITECTURAL AND MECHANICAL PLANS FOR DETAILS.
- REFER TO ARCHITECTURAL AND STRUCTURAL PLANS FOR EXACT SIZE AND DETAILS OF THE INTERNAL STORMWATER STORAGE SYSTEM.
- REFER TO ARCHITECTURAL AND MECHANICAL PLANS FOR LOCATION AND CONNECTIONS AND DETAILS OF THE INTERNAL STORMWATER STORAGE SYSTEM AND EMERGENCY OVERFLOW PIPING.

PROPOSED WATER SERVICE TABLE (1+000) - BUILDING 1

Station	FIG ELEVATION	TOP OF WATERMAIN	DESCRIPTION
1+000.00	62.93	60.79 *	ROLLED 200mm Ø WM TEE CONNECTION TO EX. 200mm Ø PVC WM
1+000.94	62.95	59.85	45° VERTICAL BEND
1+001.57	62.95	59.85	WM TO CROSS ABOVE EX. 375mm Ø SAN. SEWER (CLEARANCE=0.61m)
1+005.89	62.94	59.85	WM TO CROSS BELOW EX. 1200mm Ø STORM SEWER (CLEARANCE=0.67m)
1+007.59	63.33	59.85	45° VERTICAL BEND
1+008.30	63.07	60.56	45° VERTICAL BEND
1+008.69	62.96	60.56	VALVE AND VALVE BOX AT PROPERTY LINE
1+009.80	62.97	60.56	CAP AT 0.5m FROM FOUNDATION WALL

PROPOSED WATER SERVICE TABLE (2+000) - BUILDING 1

Station	FIG ELEVATION	TOP OF WATERMAIN	DESCRIPTION
2+000.00	62.93	60.78 *	ROLLED 200mm Ø WM TEE CONNECTION TO EX. 200mm Ø PVC WM
2+000.92	62.95	59.85	45° VERTICAL BEND
2+001.54	62.95	59.85	WM TO CROSS ABOVE EX. 375mm Ø SAN. SEWER (CLEARANCE=0.61m)
2+005.93	62.94	59.85	WM TO CROSS BELOW EX. 1200mm Ø STORM SEWER (CLEARANCE=0.67m)
2+007.63	63.33	59.85	45° VERTICAL BEND
2+008.33	63.07	60.55	45° VERTICAL BEND
2+008.65	62.96	60.55	VALVE AND VALVE BOX AT PROPERTY LINE
2+009.86	62.97	60.56	CAP AT 0.5m FROM FOUNDATION WALL

* CONNECTION TO EXISTING 200mm Ø PVC WATERMAIN, EXACT ELEVATION TO BE FIELD DETERMINED.
 ** PROVIDE THERMAL INSULATION AS PER CITY OF OTTAWA DETAIL W22 IN SHALLOW TRENCHES AND/OR CITY OF OTTAWA W23 ADJACENT TO OPEN STRUCTURES.

OWNER INFORMATION
 HOPPNER HOLDINGS INC.
 1818 BRADLEY SIDE ROAD,
 CARP, ONTARIO K0A 1L0
 KEN HOPPNER
 PHONE: 613-831-5490
 khoppner@morleyhoppner.com

No.	REVISION	DATE	BY
7.	REISSUED FOR ZBLA AND SPC APPLICATIONS	FEB 4/26	FST
6.	REVISED PER CITY COMMENTS	SEPT 4/24	FST
5.	REVISED PER CITY COMMENTS	JUN 27/24	FST
4.	REVISED PER CITY COMMENTS	APR 16/24	FST
3.	REVISED PER CITY COMMENTS	MAR 9/24	FST
2.	REVISED PER CITY COMMENTS	OCT 16/23	FST
1.	ISSUED FOR SPC APPLICATION	FEB 22/23	FST

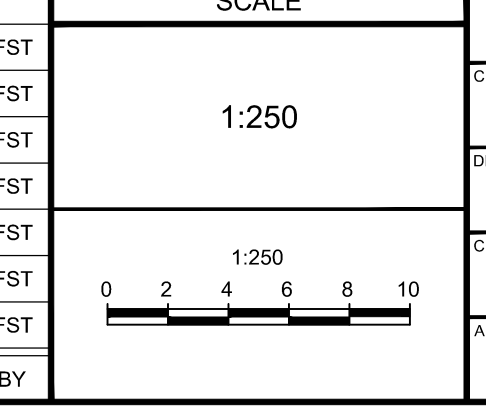

FOR REVIEW ONLY

DESIGN	CV/KD
CHECKED	FST
DRAWN	FST
CHECKED	FST
APPROVED	FST



LOCATION	CITY OF OTTAWA 2026 SCOTT STREET
DRAWING NAME	GENERAL PLAN OF SERVICES
PROJECT No.	121302
REV	REV # 7
DRAWING No.	121302-GP

NOTE:
 THE POSITION OF ALL POLE LINES, CONDUITS, WATERMANS, SEWERS AND OTHER UNDERGROUND AND OVERGROUND UTILITIES AND STRUCTURES IS NOT NECESSARILY SHOWN ON THE CONTRACT DRAWINGS, AND WHERE SHOWN, THE ACCURACY OF THE POSITION OF SUCH UTILITIES AND STRUCTURES IS NOT GUARANTEED. BEFORE STARTING WORK, DETERMINE THE EXACT LOCATION OF ALL SUCH UTILITIES AND STRUCTURES AND ASSUME ALL LIABILITY FOR DAMAGE TO THEM.

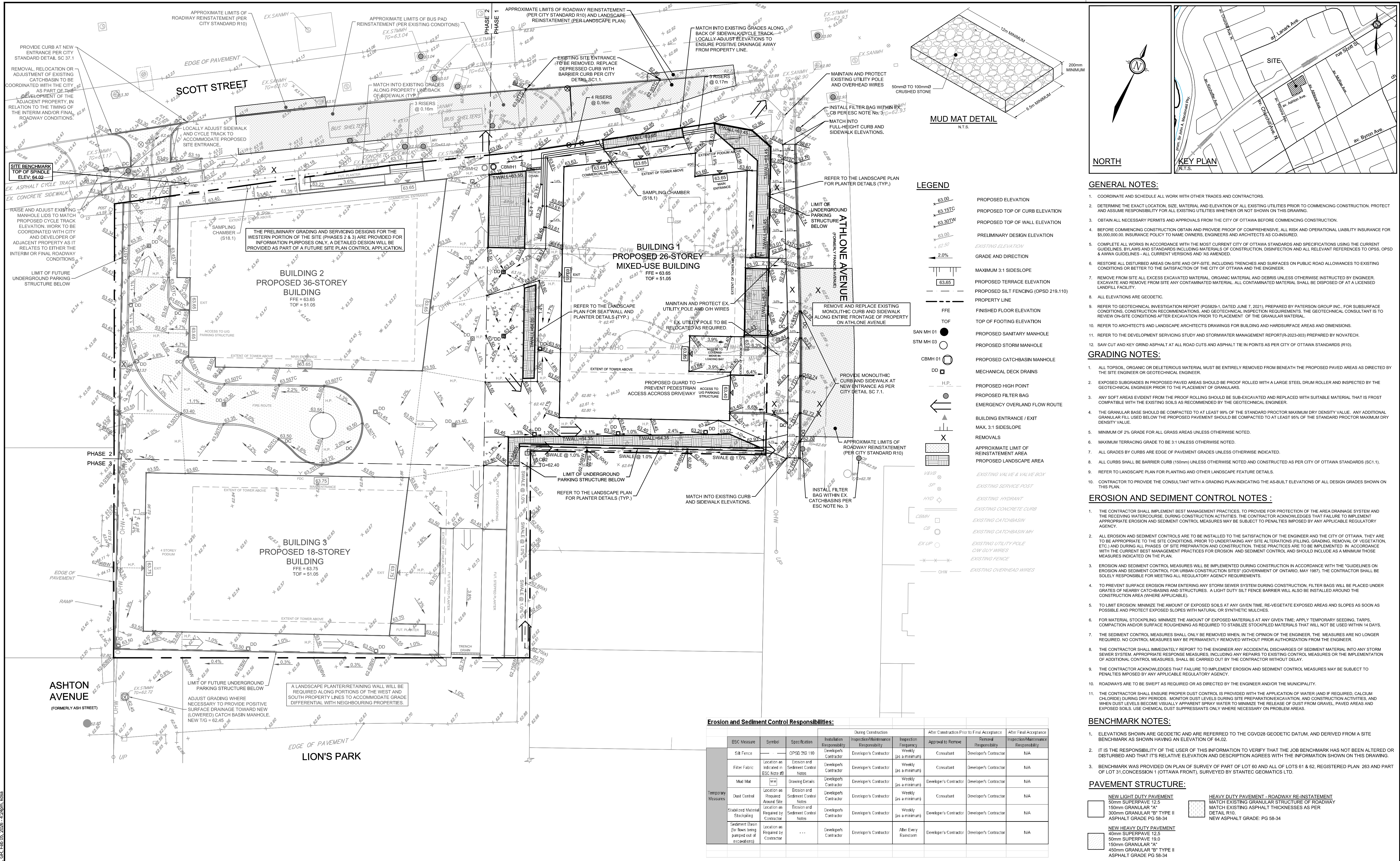

GENERAL NOTES:

- COORDINATE AND SCHEDULE ALL WORK WITH OTHER TRADES AND CONTRACTORS.
- DETERMINE THE EXACT LOCATION, SIZE, MATERIAL AND ELEVATION OF ALL EXISTING UTILITIES PRIOR TO COMMENCING CONSTRUCTION. PROTECT AND ASSUME RESPONSIBILITY FOR ALL EXISTING UTILITIES WHETHER OR NOT SHOWN ON THIS DRAWING.
- OBTAIN ALL NECESSARY PERMITS AND APPROVALS FROM THE CITY OF OTTAWA BEFORE COMMENCING CONSTRUCTION.
- BEFORE COMMENCING CONSTRUCTION OBTAIN AND PROVIDE PROOF OF COMPREHENSIVE, ALL RISK AND OPERATIONAL LIABILITY INSURANCE FOR \$5,000,000.00. INSURANCE POLICY TO NAME OWNERS, ENGINEERS AND ARCHITECTS AS CO-INSURED.
- COMPLETE ALL WORKS IN ACCORDANCE WITH THE MOST CURRENT CITY OF OTTAWA STANDARDS AND SPECIFICATIONS USING THE CURRENT GUIDELINES, BYLAWS AND STANDARDS INCLUDING MATERIALS OF CONSTRUCTION, DISINFECTION AND ALL RELEVANT REFERENCES TO OPSS, OPSD & AWWA GUIDELINES - ALL CURRENT VERSIONS AND AS AMENDED.
- RESTORE ALL DISTURBED AREAS ON-SITE AND OFF-SITE, INCLUDING TRENCHES AND SURFACES ON PUBLIC ROAD ALLOWANCES TO EXISTING CONDITIONS OR BETTER TO THE SATISFACTION OF THE CITY OF OTTAWA AND THE ENGINEER.
- REMOVE FROM SITE ALL EXCESS EXCAVATED MATERIAL, ORGANIC MATERIAL AND DEBRIS UNLESS OTHERWISE INSTRUCTED BY ENGINEER. EXCAVATE AND REMOVE FROM SITE ANY CONTAMINATED MATERIAL. ALL CONTAMINATED MATERIAL SHALL BE DISPOSED OF AT A LICENSED LANDFILL FACILITY.
- ALL ELEVATIONS ARE GEODETIC.
- REFER TO GEOTECHNICAL INVESTIGATION REPORT (PG628-21, DATED JUNE 7, 2021), PREPARED BY PATERSON GROUP INC., FOR SUBSURFACE CONDITIONS, CONSTRUCTION RECOMMENDATIONS, AND GEOTECHNICAL INSPECTION REQUIREMENTS. THE GEOTECHNICAL CONSULTANT IS TO REVIEW ON-SITE CONDITIONS AFTER EXCAVATION PRIOR TO PLACEMENT OF THE GRANULAR MATERIAL.
- REFER TO ARCHITECTS AND LANDSCAPE ARCHITECTS DRAWINGS FOR BUILDING AND HARDSURFACE AREAS AND DIMENSIONS.
- REFER TO THE DEVELOPMENT SERVICING STUDY AND STORMWATER MANAGEMENT REPORT (S-2023-003) PREPARED BY NOVATECH.
- SAW CUT AND KEY GRIND ASPHALT AT ALL ROAD CUTS AND ASPHALT TIE IN POINTS AS PER CITY OF OTTAWA STANDARDS (R10).

GRADING NOTES:

- ALL TOPSOIL, ORGANIC OR DELETERIOUS MATERIAL MUST BE ENTIRELY REMOVED FROM BENEATH THE PROPOSED PAVED AREAS AS DIRECTED BY THE SITE ENGINEER OR GEOTECHNICAL ENGINEER.
- EXPOSED SUBGRADES IN PROPOSED PAVED AREAS SHOULD BE PROOF ROLLED WITH A LARGE STEEL DRUM ROLLER AND INSPECTED BY THE GEOTECHNICAL ENGINEER PRIOR TO THE PLACEMENT OF GRANULARS.
- ANY SOFT AREAS EVIDENT FROM THE PROOF ROLLING SHOULD BE SUB-EXCAVATED AND REPLACED WITH SUITABLE MATERIAL THAT IS FROST COMPATIBLE WITH THE EXISTING SOILS AS RECOMMENDED BY THE GEOTECHNICAL ENGINEER.
- THE GRANULAR BASE SHOULD BE COMPACTED TO AT LEAST 99% OF THE STANDARD PROCTOR MAXIMUM DRY DENSITY VALUE. ANY ADDITIONAL GRANULAR FILL USED BELOW THE PROPOSED PAVEMENT SHOULD BE COMPACTED TO AT LEAST 95% OF THE STANDARD PROCTOR MAXIMUM DRY DENSITY VALUE.
- MINIMUM OF 2% GRADE FOR ALL GRASS AREAS UNLESS OTHERWISE NOTED.
- MAXIMUM TERRACING GRADE TO BE 3:1 UNLESS OTHERWISE INDICATED.
- ALL GRADES BY CURBS ARE EDGE OF PAVEMENT GRADES UNLESS OTHERWISE INDICATED.
- ALL CURBS SHALL BE BARRIER CURB (150mm) UNLESS OTHERWISE NOTED AND CONSTRUCTED AS PER CITY OF OTTAWA STANDARDS (SC1.1).
- REFER TO LANDSCAPE PLAN FOR PLANTING AND OTHER LANDSCAPE FEATURE DETAILS.
- CONTRACTOR TO PROVIDE THE CONSULTANT WITH A GRADING PLAN INDICATING THE AS-BUILT ELEVATIONS OF ALL DESIGN GRADES SHOWN ON THIS PLAN.

EROSION AND SEDIMENT CONTROL NOTES:

- THE CONTRACTOR SHALL IMPLEMENT BEST MANAGEMENT PRACTICES, TO PROVIDE FOR PROTECTION OF THE AREA DRAINAGE SYSTEM AND THE RECEIVING WATER COURSE, DURING CONSTRUCTION. THE CONTRACTOR ACKNOWLEDGES THAT FAILURE TO IMPLEMENT APPROPRIATE EROSION AND SEDIMENT CONTROL MEASURES MAY BE SUBJECT TO PENALTIES IMPOSED BY ANY APPLICABLE REGULATORY AGENCY.
- ALL EROSION AND SEDIMENT CONTROLS ARE TO BE INSTALLED TO THE SATISFACTION OF THE ENGINEER AND THE CITY OF OTTAWA. THEY ARE TO BE APPROPRIATE TO THE SITE CONDITIONS, PRIOR TO UNDERTAKING ANY SITE ALTERATIONS INCLUDING, GRADING, REMOVAL OF VEGETATION, ETC. AND DURING ALL PHASES OF SITE PREPARATION AND CONSTRUCTION. THESE PRACTICES ARE TO BE IMPLEMENTED IN ACCORDANCE WITH THE CURRENT BEST MANAGEMENT PRACTICES FOR EROSION AND SEDIMENT CONTROL AND SHOULD INCLUDE AS A MINIMUM THOSE MEASURES INDICATED ON THE PLAN.
- EROSION AND SEDIMENT CONTROL MEASURES WILL BE IMPLEMENTED DURING CONSTRUCTION IN ACCORDANCE WITH THE "GUIDELINES ON EROSION AND SEDIMENT CONTROL FOR URBAN CONSTRUCTION SITES" (GOVERNMENT OF ONTARIO, MAY 1987). THE CONTRACTOR SHALL BE SOLELY RESPONSIBLE FOR MEETING ALL REGULATORY AGENCY REQUIREMENTS.
- TO PREVENT SURFACE EROSION FROM ENTERING ANY STORM SEWER SYSTEM DURING CONSTRUCTION, FILTER BAGS WILL BE PLACED UNDER GRATES OF NEARBY CATCHBASINS AND STRUCTURES. A LIGHT DUTY SILT FENCE BARRIER WILL ALSO BE INSTALLED AROUND THE CONSTRUCTION AREA (WHERE APPLICABLE).
- TO LIMIT EROSION: MINIMIZE THE AMOUNT OF EXPOSED SOILS AT ANY GIVEN TIME. RE-VEGETATE EXPOSED AREAS AND SLOPES AS SOON AS POSSIBLE AND PROTECT EXPOSED SLOPES WITH NATURAL OR SYNTHETIC MULCHES.
- FOR MATERIAL STOCKPILING: MINIMIZE THE AMOUNT OF EXPOSED MATERIALS AT ANY GIVEN TIME. APPLY TEMPORARY SEEDING, TARPS, COMPACTION AND/OR SURFACE ROUGHENING AS REQUIRED TO STABILIZE STOCKPILED MATERIALS THAT WILL NOT BE USED WITHIN 14 DAYS.
- THE SEDIMENT CONTROL MEASURES SHALL ONLY BE REMOVED WHEN, IN THE OPINION OF THE ENGINEER, THE MEASURES ARE NO LONGER REQUIRED. NO CONTROL MEASURES MAY BE PERMANENTLY REMOVED WITHOUT PRIOR AUTHORIZATION FROM THE ENGINEER.
- THE CONTRACTOR SHALL IMMEDIATELY REPORT TO THE ENGINEER ANY ACCIDENTAL DISCHARGES OF SEDIMENT MATERIAL INTO ANY STORM SEWER SYSTEM. APPROPRIATE REPAIRS TO EXISTING CONTROL MEASURES, INCLUDING ANY REPAIRS TO EXISTING CONTROL MEASURES OR THE IMPLEMENTATION OF ADDITIONAL CONTROL MEASURES, SHALL BE CARRIED OUT BY THE CONTRACTOR WITHOUT DELAY.
- THE CONTRACTOR ACKNOWLEDGES THAT FAILURE TO IMPLEMENT EROSION AND SEDIMENT CONTROL MEASURES MAY BE SUBJECT TO PENALTIES IMPOSED BY ANY APPLICABLE REGULATORY AGENCY.
- ROADWAYS ARE TO BE SWEEP AS REQUIRED OR AS DIRECTED BY THE ENGINEER AND/OR THE MUNICIPALITY.
- THE CONTRACTOR SHALL ENSURE PROPER DUST CONTROL IS PROVIDED WITH THE APPLICATION OF WATER (AND IF REQUIRED, CALCIUM CHLORIDE) DURING DRY PERIODS. MONITOR DUST LEVELS DURING SITE PREPARATION/EXCAVATION, AND CONSTRUCTION ACTIVITIES, AND WHEN DUST LEVELS BECOME VISUALLY APPARENT SPRAY WATER TO MINIMIZE THE RELEASE OF DUST FROM GRAVEL, PAVED AREAS AND EXPOSED SOILS. USE CHEMICAL DUST SUPPRESSANTS ONLY WHERE NECESSARY ON PROBLEM AREAS.

BENCHMARK NOTES:

- ELEVATIONS SHOWN ARE GEODETIC AND ARE REFERRED TO THE CGVD28 GEODETIC DATUM, AND DERIVED FROM A SITE BENCHMARK AS SHOWN HAVING AN ELEVATION OF 64.02.
- IT IS THE RESPONSIBILITY OF THE USER OF THIS INFORMATION TO VERIFY THAT THE JOB BENCHMARK HAS NOT BEEN ALTERED OR DISTURBED AND THAT ITS RELATIVE ELEVATION AND DESCRIPTION AGREES WITH THE INFORMATION SHOWN ON THIS DRAWING.
- BENCHMARK WAS PROVIDED ON PLAN OF SURVEY OF PART OF LOT 60 AND ALL OF LOTS 61 & 62, REGISTERED PLAN 263 AND PART OF LOT 31, CONCESSION 1 (OTTAWA FRONT), SURVEYED BY STANTEC GEOMATICS LTD.

PAVEMENT STRUCTURE:

NEW LIGHT DUTY PAVEMENT
 50mm SUPERPAVE 12.5
 150mm GRANULAR "A"
 300mm GRANULAR "B" TYPE II
 ASPHALT GRADE PG 58-34

NEW HEAVY DUTY PAVEMENT
 40mm SUPERPAVE 12.5
 50mm SUPERPAVE 19.0
 150mm GRANULAR "A"
 450mm GRANULAR "B" TYPE II
 ASPHALT GRADE PG 58-34

HEAVY DUTY PAVEMENT - ROADWAY RE-INSTATEMENT
 MATCH EXISTING GRANULAR STRUCTURE OF ROADWAY
 MATCH EXISTING ASPHALT THICKNESSES AS PER DETAIL R10.
 NEW ASPHALT GRADE: PG 58-34

MUD MAT DETAIL
N.T.S.

LEGEND

- 63.00 PROPOSED ELEVATION
- 63.15TC PROPOSED TOP OF CURB ELEVATION
- 63.30TW PROPOSED TOP OF WALL ELEVATION
- 63.00 PRELIMINARY DESIGN ELEVATION
- EXISTING ELEVATION
- GRADE AND DIRECTION
- MAXIMUM 3:1 SIDESLOPE
- 63.65 PROPOSED TERRACE ELEVATION
- PROPOSED SILT FENCING (OPSD 219.110)
- PROPERTY LINE
- FINISHED FLOOR ELEVATION
- TOP OF FOOTING ELEVATION
- PROPOSED SANITARY MANHOLE
- PROPOSED STORM MANHOLE
- PROPOSED CATCHBASIN MANHOLE
- MECHANICAL DECK DRAINS
- PROPOSED HIGH POINT
- PROPOSED FILTER BAG EMERGENCY OVERLAND FLOW ROUTE
- BUILDING ENTRANCE / EXIT MAX. 3:1 SIDESLOPE
- REMOVALS
- APPROXIMATE LIMIT OF REINSTATEMENT AREA
- PROPOSED LANDSCAPE AREA
- EXISTING VALVE & VALVE BOX
- EXISTING SERVICE POST
- EXISTING HYDRANT
- EXISTING CONCRETE CURB
- EXISTING CATCHBASIN
- EXISTING CATCHBASIN MH
- EXISTING UTILITY POLE
- OH GUY WIRES
- EXISTING FENCE
- EXISTING OVERHEAD WIRES

Erosion and Sediment Control Responsibilities:

ESC Measure	Symbol	Specification	Installation Responsibility	Inspection/Maintenance Responsibility	Inspection Frequency	After Construction	
						Prior to Final Acceptance Approval to Remove	Final Acceptance Removal Responsibility
Silt Fence	---	OPSD 210.110	Developer's Contractor	Developer's Contractor	Weekly (as a minimum)	Consultant	Developer's Contractor
Filter Fabric	Location as Indicated in ESC Note #8	Erosion and Sediment Control Notes	Developer's Contractor	Developer's Contractor	Weekly (as a minimum)	Consultant	Developer's Contractor
Mud Mat	[M]	Drawing Details	Developer's Contractor	Developer's Contractor	Weekly (as a minimum)	Developer's Contractor	Developer's Contractor
Dust Control	Location as Required	Erosion and Sediment Control Notes	Developer's Contractor	Developer's Contractor	Weekly (as a minimum)	Consultant	Developer's Contractor
Stabilized Material Stockpiling	Location as Required by Contractor	Erosion and Sediment Control Notes	Developer's Contractor	Developer's Contractor	Weekly (as a minimum)	Developer's Contractor	Developer's Contractor
Sediment Basin (for flows being pumped out of excavations)	Location as Required by Contractor	---	Developer's Contractor	Developer's Contractor	After Every Rainstorm	Developer's Contractor	Developer's Contractor

NOTE:
 THE POSITION OF ALL POLE LINES, CONDUITS, WATERMANS, SEWERS AND OTHER UNDERGROUND AND OVERGROUND UTILITIES AND STRUCTURES IS NOT NECESSARILY SHOWN ON THE CONTRACT DRAWINGS, AND WHERE SHOWN, THE ACCURACY OF THE POSITION OF SUCH UTILITIES AND STRUCTURES IS NOT GUARANTEED. BEFORE STARTING WORK, DETERMINE THE EXACT LOCATION OF ALL SUCH UTILITIES AND STRUCTURES AND ASSUME ALL LIABILITY FOR DAMAGE TO THEM.



OWNER INFORMATION
 HOPPNER HOLDINGS INC.
 1818 BRADLEY SIDE ROAD,
 CARP, ONTARIO K0A 1L0
 KEN HOPPNER
 PHONE: 613-831-5490
 khoppner@morleyhoppner.com

No.	REVISION	DATE	BY
7.	REISSUED FOR ZBLA AND SPC APPLICATIONS	FEB 4/26	FST
6.	REVISED PER CITY COMMENTS	SEPT 4/24	FST
5.	REVISED PER CITY COMMENTS	JUN 27/24	FST
4.	REVISED PER CITY COMMENTS	APR 16/24	FST
3.	REVISED PER CITY COMMENTS	MAR 9/24	FST
2.	REVISED PER CITY COMMENTS	OCT 16/23	FST
1.	ISSUED FOR SPC APPLICATION	FEB 22/23	FST

SCALE
 1:250

FOR REVIEW ONLY

DESIGN	DATE
CHECKED	KD
CHECKED	FST
DRAWN	FST
CHECKED	KD
CHECKED	FST
APPROVED	FST

NOVATECH
 Engineers, Planners & Landscape Architects
 Suite 200, 240 Michael Cowpland Drive
 Ottawa, Ontario, Canada K2M 1P6
 Telephone: (613) 254-9643
 Facsimile: (613) 254-5867
 Website: www.novatech-eng.com

LOCATION
 CITY OF OTTAWA
 2026 SCOTT STREET

DRAWING NAME
 GRADING AND EROSION AND SEDIMENT CONTROL PLAN

PROJECT No. 121302
REV # 7
DRAWING No. 121302-GR
PLAN # 18976

M:\2023\121302\2023\2023-02-28\121302-GR.dwg, CR, Feb 05, 2025, 2:28pm, kshu

D07-12-23-0019

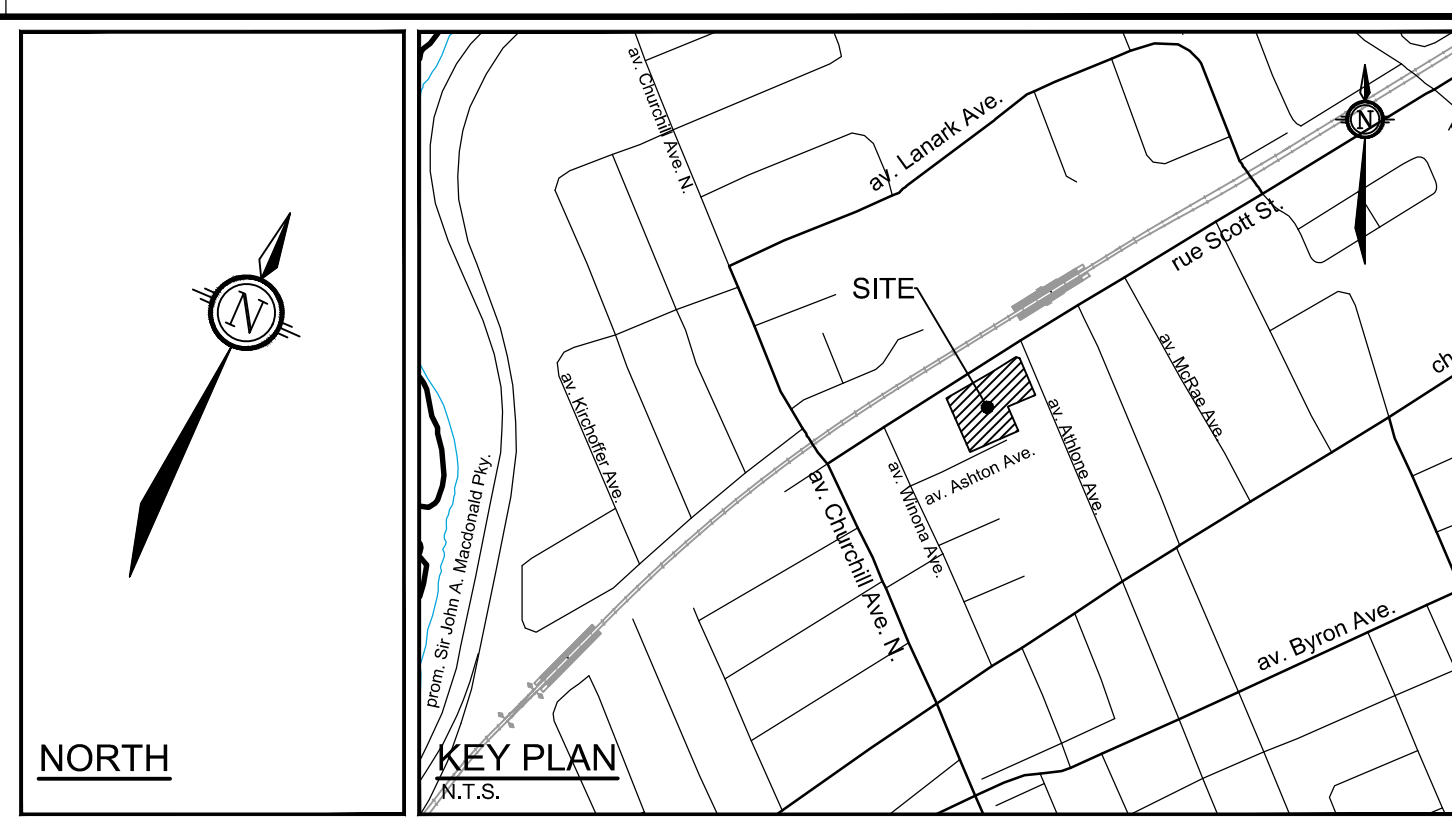
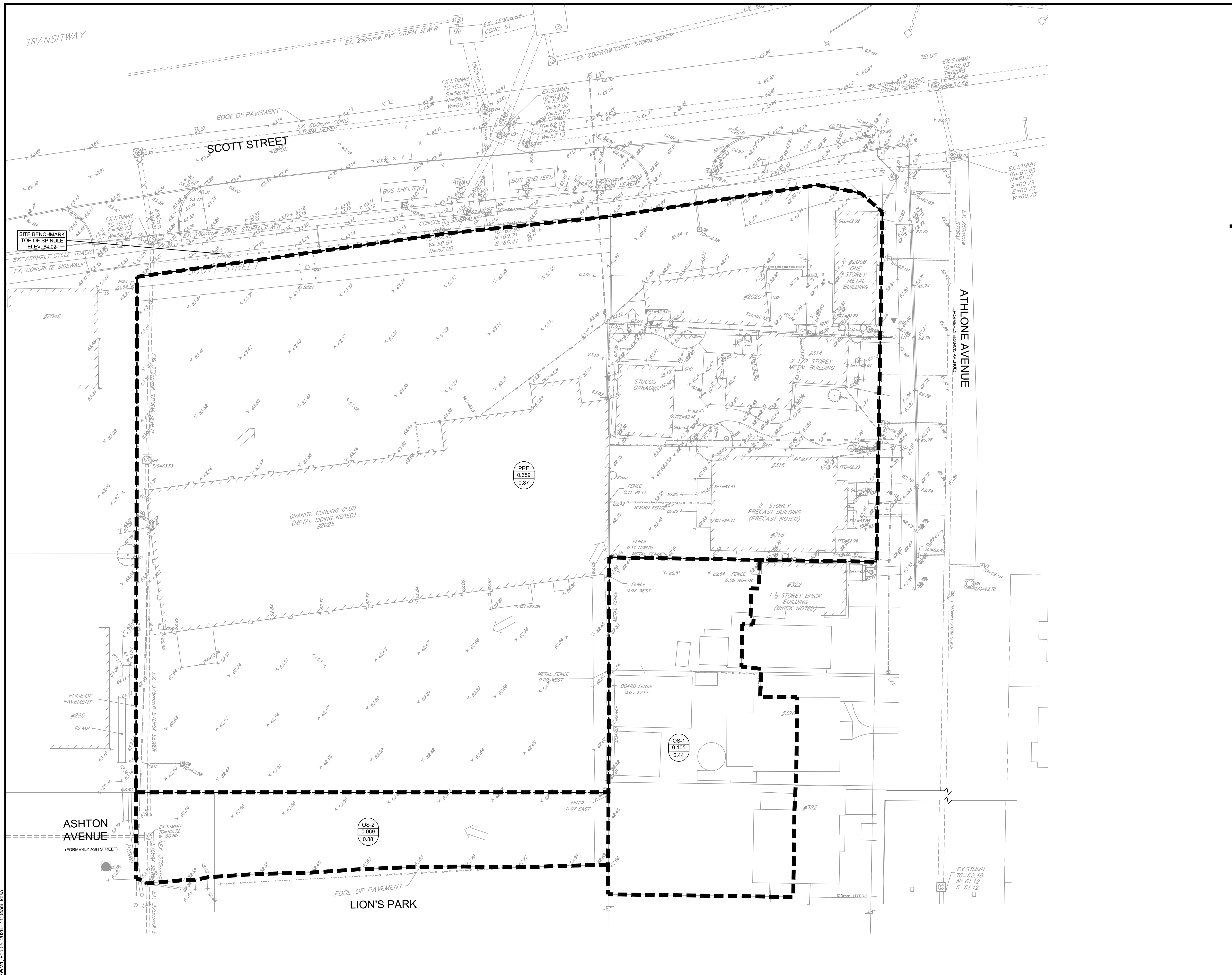

LEGEND

	DRAINAGE AREA LIMITS
	PRE-DEVELOPMENT AREA ID
	PRE-DEVELOPMENT DRAINAGE AREA (ha)
	1.5 YEAR WEIGHTED RUNOFF COEFFICIENT
	EXISTING CONCRETE CURB
	EXISTING VALVE & VALVE BOX
	EXISTING SERVICE POST
	EXISTING HYDRANT
	EXISTING CATCHBASIN
	EXISTING CATCHBASIN MH
	EXISTING UTILITY POLE GW GUY WIRES
	EXISTING DRAINAGE DIRECTION ARROWS
	EXISTING OVERLAND FLOW

- BENCHMARK NOTES:**
- ELEVATIONS SHOWN ARE GEODETIC AND ARE REFERRED TO THE CGVD28 GEODETIC DATUM. DERIVED ARE DERIVED FROM A SITE BENCHMARK AS SHOWN ON P6 HAVING AN ELEVATION OF 64.02.
 - IT IS THE RESPONSIBILITY OF THE USER OF THIS INFORMATION TO VERIFY THAT THE JOB BENCHMARK HAS NOT BEEN ALTERED OR DISTURBED AND THAT ITS RELATIVE ELEVATION AND DESCRIPTION AGREES WITH THE INFORMATION SHOWN ON THIS DRAWING.
 - BENCHMARK WAS PROVIDED ON PLAN OF SURVEY OF PART OF LOT 60 AND ALL OF LOTS 61 & 62, REGISTERED PLAN 263 AND PART OF LOT 31, CONCESSION 1 (OTTAWA FRONT), SURVEYED BY STANTEC GEOMATICS LTD.

NOTE:
THE POSITION OF ALL POLE LINES, CONDUITS, WATERMANS, SEWERS AND OTHER UNDERGROUND AND OVERGROUND UTILITIES AND STRUCTURES IS NOT NECESSARILY SHOWN ON THE CONTRACT DRAWINGS, AND WHERE SHOWN, THE ACCURACY OF THE POSITION OF SUCH UTILITIES AND STRUCTURES IS NOT GUARANTEED. BEFORE STARTING WORK, DETERMINE THE EXACT LOCATION OF ALL SUCH UTILITIES AND STRUCTURES AND ASSUME ALL LIABILITY FOR DAMAGE TO THEM.

OWNER INFORMATION
HOPPNER HOLDINGS INC.
1818 BRADLEY SIDE ROAD,
CARP, ONTARIO K0A 1L0
KEN HOPPNER
PHONE: 613-831-5490
khoppner@morleyhoppner.com

No.	REVISION	DATE	BY
6.	REISSUED FOR ZBLA AND SPC APPLICATIONS	FEB 4/26	FST
5.	REVISED PER CITY COMMENTS	SEPT 4/24	FST
4.	REVISED PER CITY COMMENTS	APR 16/24	FST
3.	REVISED PER CITY COMMENTS	MAR 9/24	FST
2.	REVISED PER CITY COMMENTS	OCT 16/23	FST
1.	ISSUED FOR SPC APPLICATION	FEB 17/23	FST

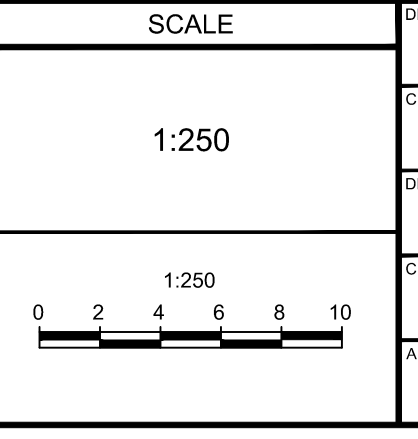

DESIGN	CV/KD	FOR REVIEW ONLY
CHECKED	FST	
DRAWN	FST	
CHECKED	FST	
APPROVED	FST	

NOVATECH
Engineers, Planners & Landscape Architects
Suite 200, 240 Michael Cowpland Drive
Ottawa, Ontario, Canada K2M 1P6
Telephone (613) 254-9643
Facsimile (613) 254-5867
Website www.novatech-eng.com

LOCATION CITY OF OTTAWA 2026 SCOTT STREET	PROJECT No. 121302
DRAWING NAME PRE-DEVELOPMENT STORM DRAINAGE AREA PLAN	REV No. REV # 6
	DRAWING No. 121302-SWM1

D07-12-23-0019

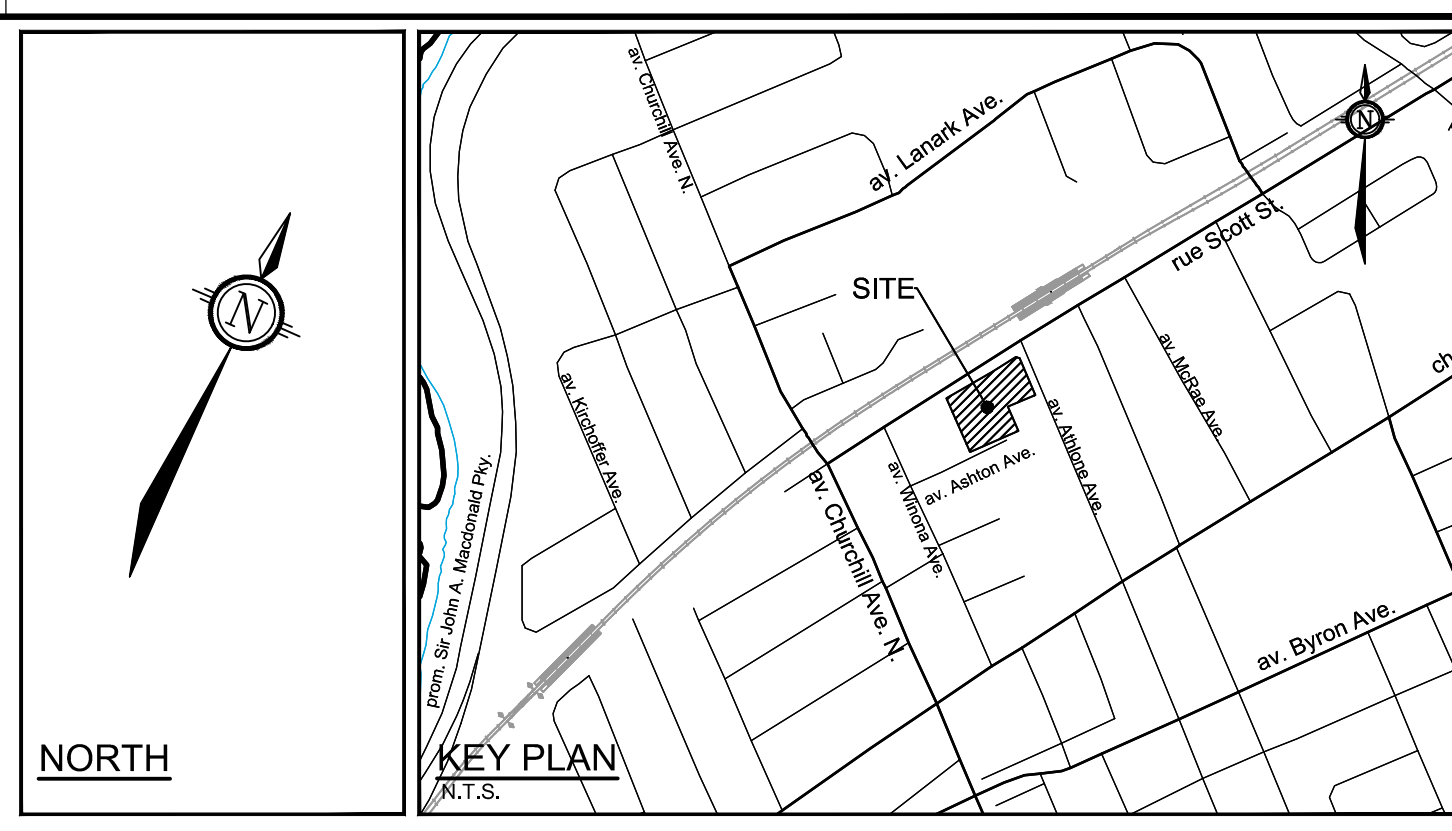
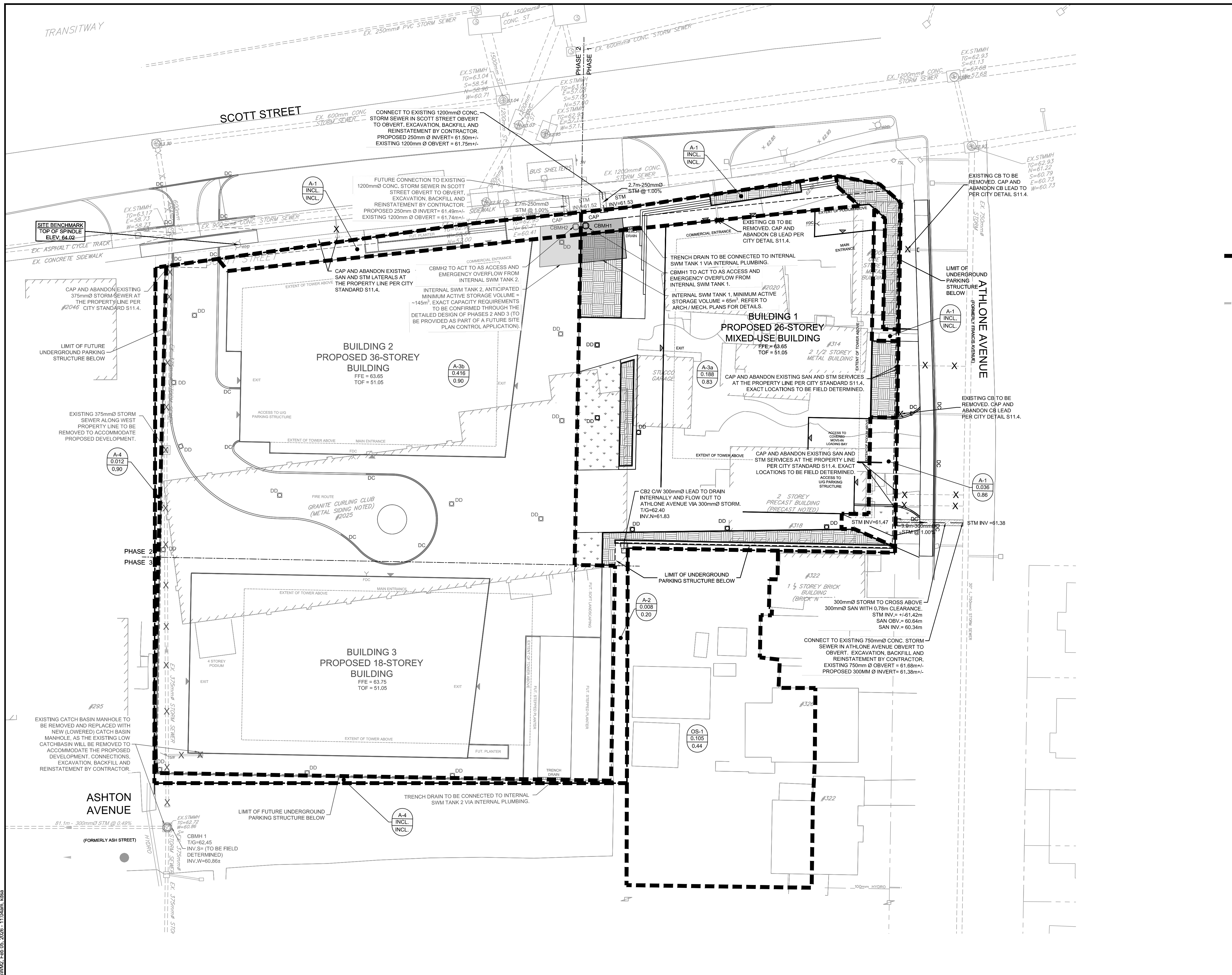

- GENERAL NOTES:**
- COORDINATE AND SCHEDULE ALL WORK WITH OTHER TRADES AND CONTRACTORS.
 - DETERMINE THE EXACT LOCATION, SIZE, MATERIAL AND ELEVATION OF ALL EXISTING UTILITIES PRIOR TO COMMENCING CONSTRUCTION. PROTECT AND ASSUME RESPONSIBILITY FOR ALL EXISTING UTILITIES WHETHER OR NOT SHOWN ON THIS DRAWING.
 - OBTAIN ALL NECESSARY PERMITS AND APPROVALS FROM THE CITY OF OTTAWA BEFORE COMMENCING CONSTRUCTION.
 - BEFORE COMMENCING CONSTRUCTION OBTAIN AND PROVIDE PROOF OF COMPREHENSIVE, ALL RISK AND OPERATIONAL LIABILITY INSURANCE FOR \$5,000,000.00, INSURANCE POLICY TO NAME OWNERS, ENGINEERS AND ARCHITECTS AS CO-INSURED.
 - COMPLETE ALL WORKS IN ACCORDANCE WITH THE MOST CURRENT CITY OF OTTAWA STANDARDS AND SPECIFICATIONS USING THE CURRENT GUIDELINES, BYLAWS AND STANDARDS INCLUDING MATERIALS OF CONSTRUCTION, DISINFECTION AND ALL RELEVANT REFERENCES TO OPSS, OPSD & AWWA GUIDELINES - ALL CURRENT VERSIONS AND 'AS AMENDED'.
 - RESTORE ALL DISTURBED AREAS ON-SITE AND OFF-SITE, INCLUDING TRENCHES AND SURFACES ON PUBLIC ROAD ALLOWANCES TO EXISTING CONDITIONS OR BETTER TO THE SATISFACTION OF THE CITY OF OTTAWA AND ENGINEER.
 - REMOVE FROM SITE ALL EXCESS EXCAVATED MATERIAL, ORGANIC MATERIAL AND DEBRIS UNLESS OTHERWISE INSTRUCTED BY ENGINEER. EXCAVATE AND REMOVE FROM SITE ANY CONTAMINATED MATERIAL. ALL CONTAMINATED MATERIAL SHALL BE DISPOSED OF AT A LICENSED LANDFILL FACILITY.
 - ALL ELEVATIONS ARE GEODETIC.
 - REFER TO GEOTECHNICAL INVESTIGATION REPORT (PG5829-1, DATED JUNE 7, 2021), PREPARED BY PATERSON GROUP INC., FOR SUBSURFACE CONDITIONS, CONSTRUCTION RECOMMENDATIONS, AND GEOTECHNICAL INSPECTION REQUIREMENTS. THE GEOTECHNICAL CONSULTANT IS TO REVIEW ON-SITE CONDITIONS AFTER EXCAVATION PRIOR TO PLACEMENT OF THE GRANULAR MATERIAL.
 - REFER TO ARCHITECT'S AND LANDSCAPE ARCHITECT'S DRAWINGS FOR BUILDING AND HARD SURFACE AREAS AND DIMENSIONS.
 - REFER TO THE DEVELOPMENT SERVICING STUDY & STORMWATER MANAGEMENT REPORT (R-2023-003) PREPARED BY NOVATECH.
 - SAW CUT AND KEY GRIND ASPHALT AT ALL ROAD CUTS AND ASPHALT TIE IN POINTS AS PER CITY OF OTTAWA STANDARDS (R10).
 - PROVIDE LINE / PARKING PAINTING AS REQUIRED PER THE ARCHITECTURAL SITE PLAN.

- BENCHMARK NOTES:**
- ELEVATIONS SHOWN ARE GEODETIC AND ARE REFERRED TO THE CGVD28 GEODETIC DATUM. DERIVED ARE DERIVED FROM A SITE BENCHMARK AS SHOWN ON PG 60 HAVING AN ELEVATION OF 64.02.
 - IT IS THE RESPONSIBILITY OF THE USER OF THIS INFORMATION TO VERIFY THAT THE JOB BENCHMARK HAS NOT BEEN ALTERED OR DISTURBED AND THAT ITS RELATIVE ELEVATION AND DESCRIPTION AGREES WITH THE INFORMATION SHOWN ON THIS DRAWING.
 - BENCHMARK WAS PROVIDED ON PLAN OF SURVEY OF PART OF LOT 60 AND ALL OF LOTS 61 & 62, REGISTERED PLAN 263 AND PART OF LOT 31, CONCESSION 1 (OTTAWA FRONT), SURVEYED BY STANTEC GEOMATICS LTD.

INTERNAL SWM TANK 1			
DESIGN EVENT	STORAGE SYSTEM	REQUIRED STORAGE VOLUMES	PROVIDED STORAGE VOLUMES
1.2 YR	CONTROLLED FLOW	11.8 m ³	
1.5 YR	PUMPED FLOW	20.2 m ³	>56 m ³
1:100 YR	RATE = 13.5 L/s	55.9 m ³	

NOTES:

- ALL DRAINAGE FROM AREA A-39 (PROPOSED PHASE 1 AMENITY AREA DECK DRAINS AND ALL BUILDING 1 ROOF DRAINS) TO BE DIRECTED TO INTERNAL STORMWATER STORAGE TANK 1. REFER TO ARCHITECTURAL AND MECHANICAL PLANS FOR DETAILS.
- REFER TO ARCHITECTURAL AND STRUCTURAL PLANS FOR EXACT SIZE AND DETAILS OF THE INTERNAL STORMWATER STORAGE SYSTEM.
- REFER TO ARCHITECTURAL AND MECHANICAL PLANS FOR LOCATION AND CONNECTIONS AND DETAILS OF THE INTERNAL STORMWATER STORAGE SYSTEM AND EMERGENCY OVERFLOW PIPING.

NOTE:
THE POSITION OF ALL POLE LINES, CONDUITS, WATERMANS, SEWERS AND OTHER UNDERGROUND AND OVERGROUND UTILITIES AND STRUCTURES IS NOT NECESSARILY SHOWN ON THE CONTRACT DRAWINGS, AND WHERE SHOWN, THE ACCURACY OF THE POSITION OF SUCH UTILITIES AND STRUCTURES IS NOT GUARANTEED. BEFORE STARTING WORK, DETERMINE THE EXACT LOCATION OF ALL SUCH UTILITIES AND STRUCTURES AND ASSUME ALL LIABILITY FOR DAMAGE TO THEM.

OWNER INFORMATION
HOPPNER HOLDINGS INC.
1818 BRADLEY SIDE ROAD,
CARP, ONTARIO K0A 1L0
KEN HOPPNER
PHONE: 613-831-5490
khoppner@morleyhoppner.com

No.	REVISION	DATE	BY
7.	REISSUED FOR ZBLA AND SPC APPLICATIONS	FEB 4/26	FST
6.	REVISED PER CITY COMMENTS	SEPT 4/24	FST
5.	REVISED PER CITY COMMENTS	JUN 27/24	FST
4.	REVISED PER CITY COMMENTS	APR 16/24	FST
3.	REVISED PER CITY COMMENTS	MAR 9/24	FST
2.	REVISED PER CITY COMMENTS	OCT 16/23	FST
1.	ISSUED FOR SPC APPLICATION	FEB 22/23	FST

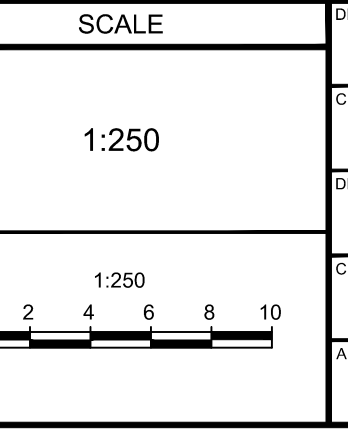

DESIGN	KD	FOR REVIEW ONLY
CHECKED	FST	
DRAWN	FST	
CHECKED	KD	
APPROVED	FST	
	FST	

NOVATECH
Engineers, Planners & Landscape Architects
Suite 200, 240 Michael Cowpland Drive
Ottawa, Ontario, Canada K2M 1P6
Telephone (613) 254-9643
Facsimile (613) 254-5867
Website www.novatech-eng.com

LOCATION	CITY OF OTTAWA 2026 SCOTT STREET
DRAWING NAME	POST-DEVELOPMENT STORM DRAINAGE AREA PLAN
PROJECT No.	121302
REV	REV # 7
DRAWING No.	121302-SWM2

D07-12-23-0019