

GENERAL NOTES:

- COORDINATE AND SCHEDULE ALL WORK WITH OTHER TRADES AND CONTRACTORS.
- DETERMINE THE EXACT LOCATION, SIZE, MATERIAL AND ELEVATION OF ALL EXISTING UTILITIES PRIOR TO COMMENCING CONSTRUCTION. PROTECT AND ASSUME RESPONSIBILITY FOR ALL EXISTING UTILITIES WHETHER OR NOT SHOWN ON THIS DRAWING.
- OBTAIN ALL NECESSARY PERMITS AND APPROVALS FROM THE CITY OF OTTAWA BEFORE COMMENCING CONSTRUCTION.
- BEFORE COMMENCING CONSTRUCTION OBTAIN AND PROVIDE PROOF OF COMPREHENSIVE, ALL RISK AND OPERATIONAL LIABILITY INSURANCE FOR \$5,000,000.00. INSURANCE POLICY TO NAME OWNERS, ENGINEERS AND ARCHITECTS AS CO-INSURED.
- RESTORE ALL DISTURBED AREAS ON-SITE AND OFF-SITE, INCLUDING TRENCHES AND SURFACES ON FORMER ALLIANCES TO EXISTING CONDITIONS OR BETTER TO THE SATISFACTION OF THE CITY OF OTTAWA AND ENGINEER.
- REMOVE FROM SITE ALL EXCESS EXCAVATED MATERIAL, ORGANIC MATERIAL AND DEBRIS UNLESS OTHERWISE INSTRUCTED BY ENGINEER. EXCAVATE AND REMOVE FROM SITE ANY CONTAMINATED MATERIAL. ALL CONTAMINATED MATERIAL SHALL BE DISPOSED OF AT A LICENSED LANDFILL FACILITY.
- ALL DIMENSIONS AND INVERTS MUST BE VERIFIED PRIOR TO CONSTRUCTION. IF THERE IS ANY DISCREPANCY THE CONTRACTOR IS TO NOTIFY THE ENGINEER PROMPTLY.
- SITE DATUM IS REFERRED TO MTM ZONE 9 NAD-83 (ORIGINAL). THE SITE BENCHMARK#1 IS SET ON TOP OF THE FIRE HYDRANT SPINDLE (ELEV. = 88.86), LOCATED OPPOSITE OF THE SITE ON DECOEUR DRIVE. BENCHMARK #2 IS A NAIL IN THE ASPHALT PATHWAY LOCATED NEAR THE NORTH-EAST CORNER OF THE SITE ALONG TENTH LINE ROAD. ELEVATIONS SHOWN ARE GEODETIC AND ARE REFERRED TO THE CGVD28 GEODETIC DATUM.
- REFER TO GEOTECHNICAL REPORT (No. PG7518-1, DATED MAY 23, 2025), PREPARED BY PATERSON GROUP FOR SUBSURFACE CONDITIONS, CONSTRUCTION RECOMMENDATIONS, AND GEOTECHNICAL INSPECTION REQUIREMENTS. THE GEOTECHNICAL CONSULTANT IS TO REVIEW ON-SITE CONDITIONS AFTER EXCAVATION PRIOR TO PLACEMENT OF THE GRANULAR MATERIAL.
- REFER TO ARCHITECT'S AND LANDSCAPE ARCHITECT'S DRAWINGS FOR BUILDING AND HARDSURFACE AREAS AND DIMENSIONS.
- REFER TO STORMWATER MANAGEMENT REPORT, PREPARED BY NOVATECH ENGINEERING CONSULTANTS LTD. DATED OCTOBER 16th, 2025
- SAW CUT AND KEY GRIND ASPHALT AT ALL ROAD CUTS AND ASPHALT TIE IN POINTS AS PER CITY OF OTTAWA STANDARDS (R10).
- PROVIDE LINE/PARKING PAINTING.
- CONTRACTOR TO PROVIDE THE CONSULTANT WITH A GENERAL PLAN OF SERVICES INDICATING ALL SERVICING AS-BUILT INFORMATION SHOWN ON THIS PLAN. AS-BUILT INFORMATION MUST INCLUDE: PIPE MATERIAL, SIZES, LENGTHS, SLOPES, INVERT AND TIG ELEVATIONS, STRUCTURE LOCATIONS, VALVE AND HYDRANT LOCATIONS, TWM ELEVATIONS AND ANY ALIGNMENT CHANGES, ETC.
- CONTRACTOR IS RESPONSIBLE FOR ALL LAYOUT FOR CONSTRUCTION PURPOSES.

SEWER NOTES:

- SPECIFICATIONS:

ITEM	SPEC. No.	REFERENCE
CATCHBASIN (600x600mm)	705.010	OPSD
STORM / SANITARY MANHOLE (1200)	701.010	OPSD
STORM / SANITARY MANHOLE (2400)	701.013	OPSD
CB, FRAME & COVER	400.020	OPSD
STORM / SANITARY MH FRAME	S25	CITY OF OTTAWA
SANITARY COVER	S24	CITY OF OTTAWA
STORM COVER (CLOSED)	S24.1	CITY OF OTTAWA
STORM COVER (OPEN)	S28.1	CITY OF OTTAWA
LANDSCAPE CATCHBASINS	S30 & S31	CITY OF OTTAWA
LANDSCAPE PERFORATED PIPE	S29	CITY OF OTTAWA
SEWER TRENCH	S6 & S7	CITY OF OTTAWA
PVC DR 35 (UNLESS SPECIFIED OTHERWISE)	COAC 650	(UNLESS SPECIFIED OTHERWISE)
STORM SEWER (>450mmØ)	PVC DR 35	
SANITARY SEWER	PVC DR 35	
CATCHBASIN LEAD	PVC DR 35	
- INSULATE ALL PIPES (SAN/STM) THAT HAVE LESS THAN 2.0m COVER WITH 50mmx1200mm HI-40 INSULATION. PROVIDE 150mm CLEARANCE BETWEEN PIPE AND INSULATION.
- SERVICES ARE TO BE CONSTRUCTED TO 1.0m FROM FACE OF BUILDING AT A MINIMUM SLOPE OF 1.0% (2.0% IS PREFERRED).
- SEWER SERVICE CONNECTIONS PER CITY OF OTTAWA DETAILS S11 AND S11.1.
- A MINIMUM OF 150 MM OF OPSS GRANULAR A SHOULD BE PLACED FOR BEDDING FOR SEWER OR WATER PIPES WHEN PLACED ON A SOIL SUBGRADE. THE BEDDING SHOULD EXTEND TO THE SPRING LINE OF THE PIPE.
- COVER MATERIAL, FROM THE SPRING LINE TO A MINIMUM OF 300 MM ABOVE THE OVERTOP OF THE PIPE, SHOULD CONSIST OF OPSS GRANULAR A (CONCRETE OR PSM PVC PIPES) OR SAND (CONCRETE PIPE). THE BEDDING AND COVER MATERIALS SHOULD BE PLACED IN MAXIMUM 225 MM THICK LIFTS AND COMPACTED TO 95% OF THE SPMD.
- WHERE HARD SURFACE AREAS ARE CONSIDERED ABOVE THE TRENCH BACKFILL, THE TRENCH BACKFILL MATERIAL WITHIN THE FROST ZONE (ABOUT 1.5 M BELOW FINISHED GRADE) AND ABOVE THE COVER MATERIAL SHOULD MATCH THE SOILS EXPOSED AT THE TRENCH WALLS TO MINIMIZE DIFFERENTIAL FROST HEAVING. THE TRENCH BACKFILL SHOULD BE PLACED IN MAXIMUM 225 MM THICK LOOSE LIFTS AND COMPACTED TO A MINIMUM OF 95% OF THE MATERIAL STANDARD PROCTOR MAXIMUM DRY DENSITY.
- FLEXIBLE CONNECTIONS ARE REQUIRED FOR CONNECTING PIPES TO MANHOLES (FOR EXAMPLE KOR-N-SEAL, PSX, POSITIVE SEAL AND DURASEAL). THE CONCRETE CRADLE FOR THE PIPE CAN BE ELIMINATED.
- THE OWNER SHALL REQUIRE THAT THE SITE SERVICING CONTRACTOR PERFORM FIELD TESTS FOR QUALITY CONTROL OF ALL SANITARY SEWERS. LEAKAGE TESTING SHALL BE COMPLETED IN ACCORDANCE WITH OPS 410.07.16, 410.07.16.04 AND 407.07.24. DYE TESTING IS TO BE COMPLETED ON ALL SANITARY SERVICES TO CONFIRM PROPER CONNECTION TO THE SANITARY SEWER MAIN. THE FIELD TESTS SHALL BE PERFORMED IN THE PRESENCE OF A CERTIFIED PROFESSIONAL ENGINEER WHO SHALL SUBMIT A CERTIFIED COPY OF THE TEST RESULTS.
- STORM MANHOLES AND CBMS ARE TO HAVE 300mm SUMPS UNLESS OTHERWISE INDICATED.
- CONTRACTOR TO TELEVIEW (CCTV) ALL PROPOSED SEWERS, 200mmØ OR GREATER PRIOR TO BASE COURSE ASPHALT. UPON COMPLETION OF CONTRACT, THE CONTRACTOR IS RESPONSIBLE TO FLUSH AND CLEAN ALL SEWERS & APPURTENANCES.
- ALL CATCHBASINS AND CATCHBASIN MANHOLES TO BE PROVIDED WITH MINIMUM 3 METER LONG PERFORATED SUBDRAINS EXTENDING IN TWO DIRECTIONS AT THE SUBGRADE LEVEL. SUBDRAIN IS TO BE PROVIDED AT THE TRANSITIONS BETWEEN DIFFERENT PAVEMENT COMPOSITIONS. THE SUBGRADE SURFACE SHOULD BE SHAPED TO PROMOTE WATER FLOW TO THE DRAINAGE LINES.
- TO REDUCE LONG-TERM LOWERING OF THE GROUNDWATER LEVEL AT THIS SITE, CLAY SEALS SHOULD BE PROVIDED IN THE SERVICE TRENCHES. THE SEALS SHOULD BE AT LEAST 1.5 M LONG AND SHOULD EXTEND FROM TRENCH WALL TO TRENCH WALL. GENERALLY, THE SEALS SHOULD EXTEND FROM THE FROST LINE AND FULLY PENETRATE THE BEDDING, SUBBEDDING AND COVER MATERIAL. THE BARRIERS SHOULD CONSIST OF RELATIVELY DRY AND COMPACTABLE BROWN SILTY CLAY PLACED IN MAXIMUM 225 MM THICK LOOSE LAYERS AND COMPACTED TO A MINIMUM OF 95% OF THE MATERIAL'S SPMD. THE CLAY SEALS SHOULD BE PLACED AT THE SITE BOUNDARIES AND AT STRATEGIC LOCATIONS AT NO MORE THAN 60 M INTERVALS IN THE SERVICE TRENCHES.

WATERMAIN NOTES:

- SPECIFICATIONS:

ITEM	SPEC. No.	REFERENCE
WATERMAIN TRENCHING	W17	CITY OF OTTAWA
THERMAL INSULATION IN SHALLOW TRENCHES	W22	CITY OF OTTAWA
WATERMAIN CROSSING BELOW SEWER/ABOVE SEWER	W25 / W25.2	CITY OF OTTAWA
WATERMAIN VALVE AND VALVE BOX	PVC DR 18	CITY OF OTTAWA
- SUPPLY AND CONSTRUCT ALL WATERMANS AND APPURTENANCES IN ACCORDANCE WITH THE CITY OF OTTAWA STANDARDS AND SPECIFICATIONS. EXCAVATION, INSTALLATION, BACKFILL AND RESTORATION OF ALL WATERMANS BY THE CONTRACTOR. CONNECTIONS AND SHUT-OFFS AT THE MAIN AND CHLORINATION OF THE WATER SYSTEM SHALL BE PERFORMED BY CITY OFFICIALS.
- WATERMAIN SHALL BE MINIMUM 2.4m DEPTH BELOW GRADE UNLESS OTHERWISE INDICATED. ANY WATERMAIN WITH LESS THAN 2.4m COVER TO BE INSULATED PER THE SEWER AND WATERMAIN NOTES AND DETAIL.
- PROVIDE MINIMUM 0.25m ABOVE, 0.5m IF BELOW, CLEARANCE BETWEEN OUTSIDE OF PIPES AT ALL CROSSINGS PER CITY OF OTTAWA STANDARDS W25/W25.2
- WATER SERVICE IS TO BE CONSTRUCTED TO WITHIN 1.0m OF FOUNDATION WALL AND CAPPED, UNLESS OTHERWISE INDICATED.
- CATHODIC PROTECTION REQUIRED FOR ALL IRON FITTINGS CITY OF OTTAWA STANDARD DETAILS W-39, 40, 41, 42, 43 AND 44.
- PROVIDE THERMAL INSULATION FOR WATERMAIN AT OPEN STRUCTURES PER CITY OF OTTAWA STANDARD DETAIL W-23.
- IF WATERMAIN MUST BE DEFLECTED TO MEET ALIGNMENT, ENSURE THAT THE AMOUNT OF DEFLECTION USED IS LESS THAN HALF THAT RECOMMENDED BY THE MANUFACTURER.

GRADING NOTES:

- ALL TOPSOIL, ORGANIC OR DELETERIOUS MATERIAL MUST BE ENTIRELY REMOVED FROM BENEATH THE PROPOSED PAVED AREAS AS DIRECTED BY THE SITE ENGINEER OR GEOTECHNICAL ENGINEER.
- NON-SPECIFIED EXISTING FILL ALONG WITH SITE-EXCAVATED SOIL CAN BE USED AS GENERAL LANDSCAPING FILL AND BENEATH EXTERIOR PARKING AREAS WHERE SETTLEMENT OF THE GROUND SURFACE IS OF MINOR CONCERN. IN LANDSCAPED AREAS, THESE MATERIALS SHOULD BE SPREAD IN THIN LIFTS AND AT LEAST COMPACTED BY THE TRACKS OF THE SPREADING EQUIPMENT TO MINIMIZE VOIDS. IF THESE MATERIALS ARE TO BE USED TO BUILD UP THE SUBGRADE LEVEL FOR AREAS TO BE PAVED, THEY SHOULD BE COMPACTED IN THIN LIFTS TO A MINIMUM DENSITY OF 95% OF THEIR RESPECTIVE SPMD. AS DIRECTED BY THE SITE ENGINEER OR GEOTECHNICAL ENGINEER.
- EXPOSED SUBGRADES IN PROPOSED PAVED AREAS SHOULD BE PROOF ROLLED WITH A LARGE STEEL DRUM ROLLER AND INSPECTED BY THE GEOTECHNICAL ENGINEER PRIOR TO THE PLACEMENT OF GRANULARS.
- IF SOFT SPOTS DEVELOP IN THE SUBGRADE DURING COMPACTION OR DUE TO CONSTRUCTION TRAFFIC, THE AFFECTED AREAS SHOULD BE EXCAVATED AND REPLACED WITH OPSS GRANULAR B TYPE II MATERIAL, AS RECOMMENDED BY THE GEOTECHNICAL ENGINEER.
- THE PAVEMENT GRANULAR BASE AND SUBBASE SHOULD BE PLACED IN MAXIMUM 300 MM THICK LIFTS AND COMPACTED TO A MINIMUM OF 99% OF THE MATERIAL'S SPMD USING SUITABLE VIBRATORY EQUIPMENT.
- MINIMUM OF 2% GRADE FOR ALL GRASS AREAS UNLESS OTHERWISE NOTED.
- MAXIMUM TRENCHING GRADE TO BE 3:1 UNLESS OTHERWISE NOTED.
- ALL GRADES BY CURBS ARE EDGE OF PAVEMENT GRADES UNLESS OTHERWISE INDICATED.
- ALL CURBS SHALL BE BARRIER CURB (150mm) UNLESS OTHERWISE NOTED AND CONSTRUCTED AS PER CITY OF OTTAWA STANDARDS (SC1.1).
- REFER TO LANDSCAPE PLAN FOR PLANTING AND OTHER LANDSCAPE FEATURE DETAILS.
- CONTRACTOR TO PROVIDE THE CONSULTANT WITH A GRADING PLAN INDICATING AS-BUILT ELEVATIONS OF ALL DESIGN GRADES SHOWN ON THIS PLAN.

PAVEMENT STRUCTURE:

- ACCESS LANES**
- 40mm HL3 OR SUPERPAVE 12.5 ASPHALTIC CONCRETE
 - 50mm HL4 OR SUPERPAVE 19.0 ASPHALTIC CONCRETE
 - 150mm OPSS GRAN "A" CRUSHED STONE
 - 450mm OPSS GRAN "B" type II
- CAR ONLY PARKING AREAS**
- 50mm HL3 OR SUPERPAVE 12.5 ASPHALTIC CONCRETE
 - 150mm OPSS GRAN "A" CRUSHED STONE
 - 300mm OPSS GRAN "B" type II
- SUBGRADE - EITHER FILL, IN SITU SOIL OR OPSS GRANULAR B TYPE I OR II MATERIAL PLACED OVER IN SITU SOIL OR FILL.**
- MINIMUM PERFORMANCE GRADED (PG) 58-34 ASPHALT CEMENT SHOULD BE UTILIZED FRO THIS PROJECT

EROSION AND SEDIMENT CONTROL NOTES:

- THE CONTRACTOR SHALL IMPLEMENT BEST MANAGEMENT PRACTICES, TO PROVIDE FOR PROTECTION OF THE AREA DRAINAGE SYSTEM AND THE RECEIVING WATERCOURSE, DURING CONSTRUCTION ACTIVITIES. THE CONTRACTOR ACKNOWLEDGES THAT FAILURE TO IMPLEMENT APPROPRIATE EROSION AND SEDIMENT CONTROL MEASURES MAY BE SUBJECT TO PENALTIES IMPOSED BY ANY APPLICABLE REGULATORY AGENCY.
- THE OWNER AGREES TO PREPARE AND IMPLEMENT AN EROSION AND SEDIMENT CONTROL PLAN TO THE SATISFACTION OF THE CITY OF OTTAWA, APPROPRIATE TO THE SITE CONDITIONS, PRIOR TO UNDERTAKING ANY SITE ALTERATIONS (FILLING, GRADING, REMOVAL OF VEGETATION, ETC.) AND DURING ALL PHASES OF SITE PREPARATION AND CONSTRUCTION IN ACCORDANCE WITH THE CURRENT BEST MANAGEMENT PRACTICES FOR EROSION AND SEDIMENT CONTROL SUCH AS BUT NOT LIMITED TO INSTALLING FILTER CLOTHS ACROSS MANHOLE/CATCHBASIN LIDS TO PREVENT SEDIMENTS FROM ENTERING STRUCTURES AND INSTALL AND MAINTAIN A LIGHT DUTY SILT FENCE BARRIER AS REQUIRED.
- THE CONTRACTOR SHALL PLACE FILTER CLOTH UNDER THE CATCHBASIN AND MANHOLE GRATES FOR THE DURATION OF CONSTRUCTION AND WILL REMAIN IN PLACE DURING ALL PHASES OF CONSTRUCTION.
- SILT FENCING FOR ENTIRE PERIMETER OF SITE, SHALL BE UTILIZED TO CONTROL EROSION FROM THE SITE DURING CONSTRUCTION.
- THE CONTRACTOR ACKNOWLEDGES THAT FAILURE TO IMPLEMENT EROSION AND SEDIMENT CONTROL MEASURES MAY BE SUBJECT TO PENALTIES IMPOSED BY ANY APPLICABLE REGULATORY AGENCY.

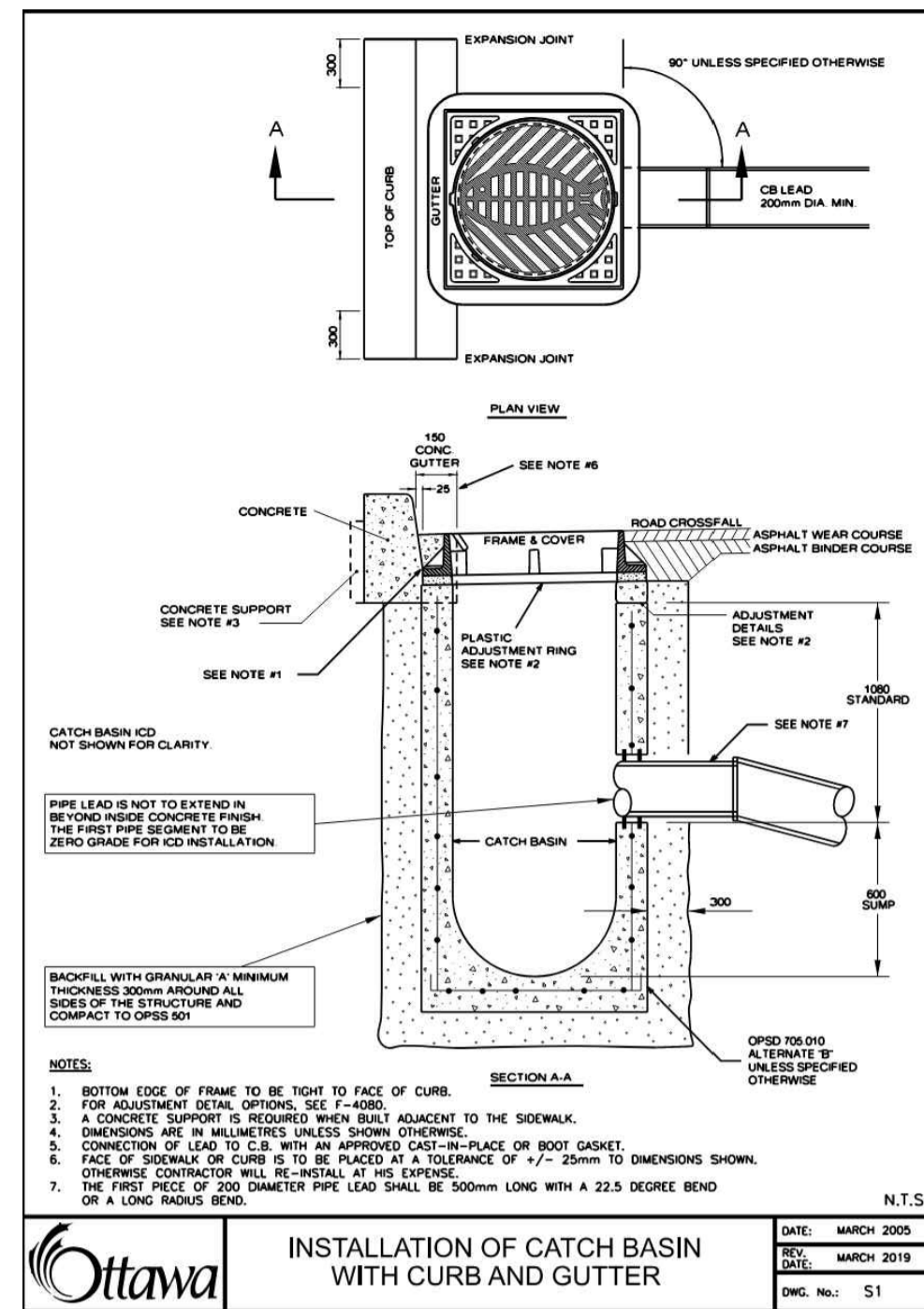

INSTALLATION OF CATCH BASIN WITH CURB AND GUTTER
DATE: MARCH 2020
REV: MARCH 2019
DWG. No.: S1

STANDARD TRENCH REINSTATEMENT IN PAVED SURFACE

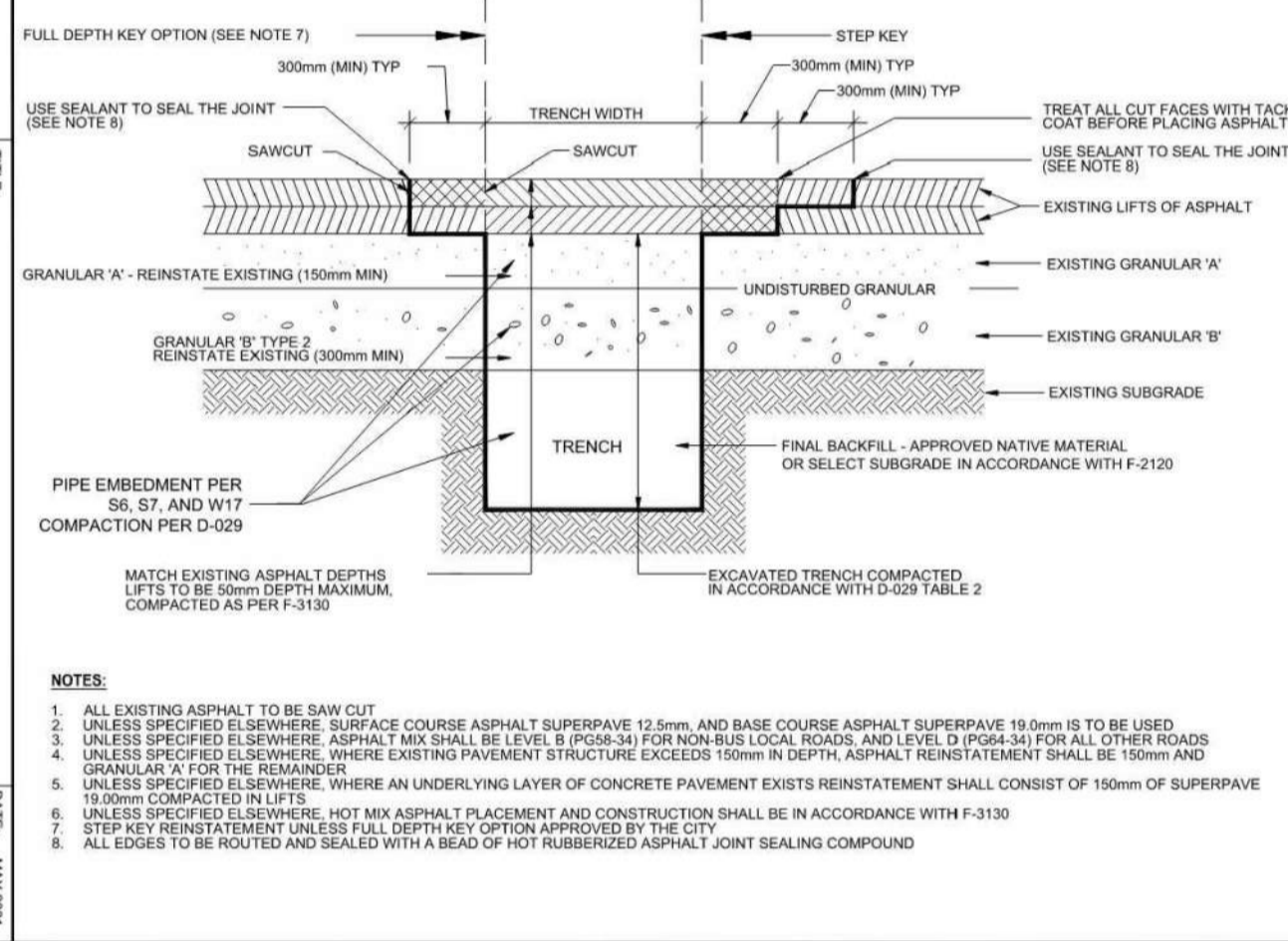

SECTION A-A
SECTION B-B
DATE: MAY 2020
REV: MARCH 2020
DWG. No.: R10

SEWER & WATERMAIN INSULATION NOTES:

- INSULATE ALL SEWER PIPES THAT HAVE LESS THAN 2.0m COVER AND ALL WATERMAIN WITH LESS THAN 2.4m OF COVER WITH EXPANDED POLYSTYRENE INSULATION AS PER OPS 1109.030.
 - THE THICKNESS OF INSULATION SHALL BE THE EQUIVALENT OF 25mm FOR EVERY 300mm REDUCTION IN THE REQUIRED DEPTH OF COVER WITH 50mm MINIMUM (SEE TABLE).
- T = THICKNESS OF INSULATION (mm)
W = WIDTH OF INSULATION (mm)
W = D + 300 (1000 mm)
D = O.D OF PIPE (mm)

COVER SEWER / WATER (mm)	INSULATION THICKNESS (mm)
2000-1700 / 2400-2100	50
1700-1400 / 2100-1800	75
1400-1100 / 1800-1500	100

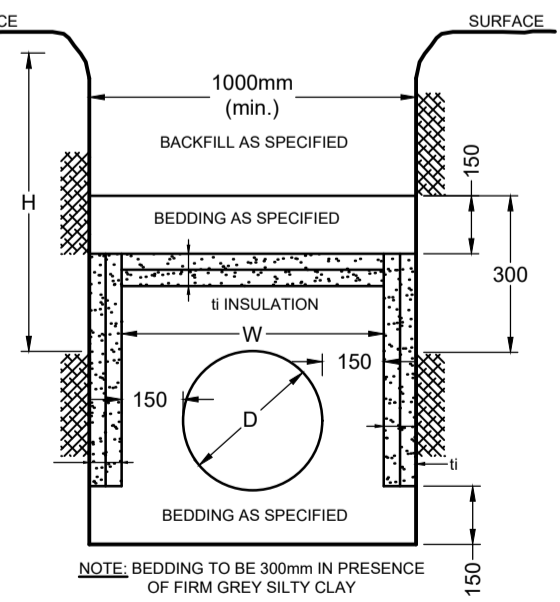

INSULATION DETAIL FOR SHALLOW SEWERS & WATERMAIN
N.T.S.

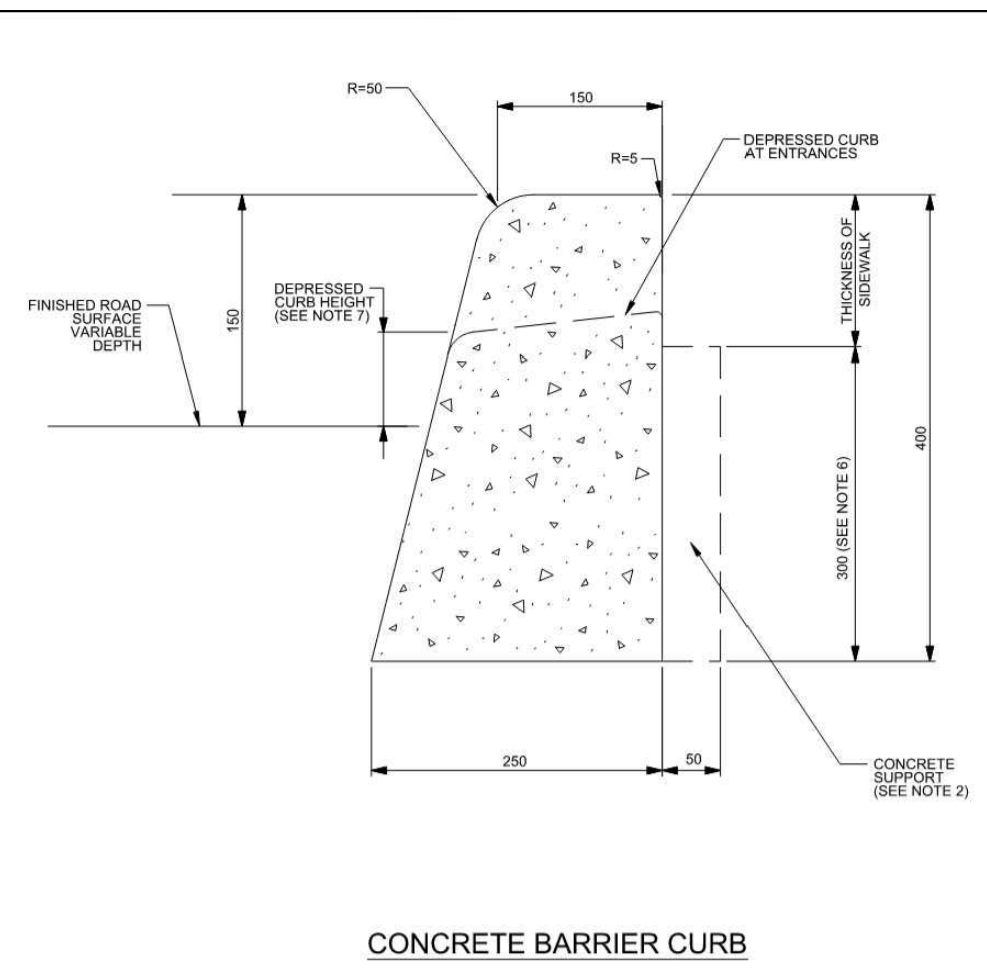

CONCRETE BARRIER CURB

- NOTES:**
- THE FULL CURB DEPTH SHALL BE CARRIED THROUGH THE DEPRESSED ACCESS CROSSING
 - A CONCRETE SUPPORT IS REQUIRED WHEN BUILT ADJACENT TO THE SIDEWALK IF AN EXTRUSION CURBING MACHINE IS USED. THE EXPANSION BIT/MANOUS MATERIAL AND THE #15 DOWELS ARE TO BE PLACED AT THE END OF THE EXTRUSION
 - ALL MEASUREMENTS ARE IN MILLIMETRES UNLESS OTHERWISE NOTED
 - EXPANSION AND DUMMY JOINTS AS PER SC3
 - FOR DEPRESSED CURB AT ENTRANCES USE 250
 - DEPRESSED CURB HEIGHT - FOR PEDESTRIAN CURB RAMPS 0 TO 6 mm AND FOR PRIVATE ENTRANCES TO 13mm

CONCRETE BARRIER CURB FOR GRANULAR BASE PAVEMENT (MODIFIED OPSD-600.110)
DATE: JAN 2003
REV: MAR 2025
DWG. No.: SC1.1

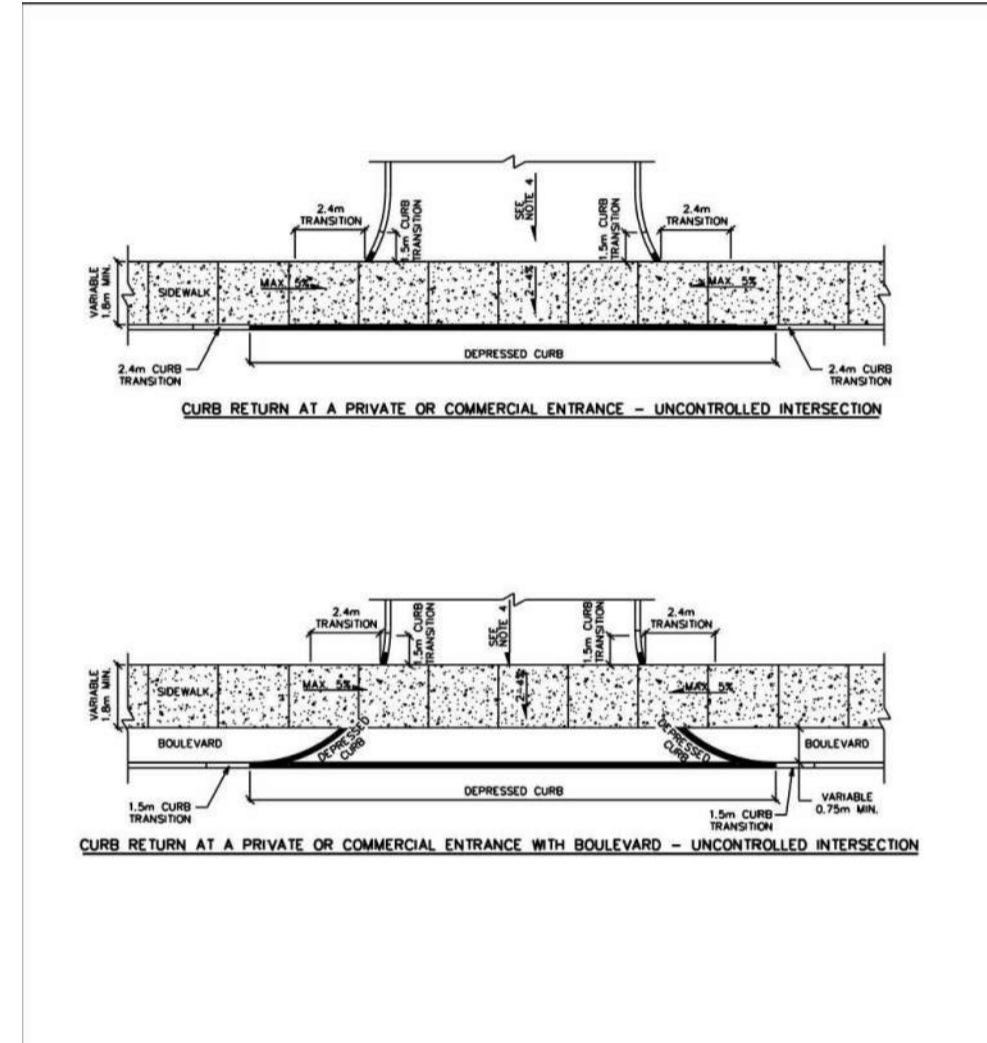

SECTION A-A
SECTION B-B
DATE: MARCH 2007
REV: MARCH 2021
DWG. No.: SC7.1

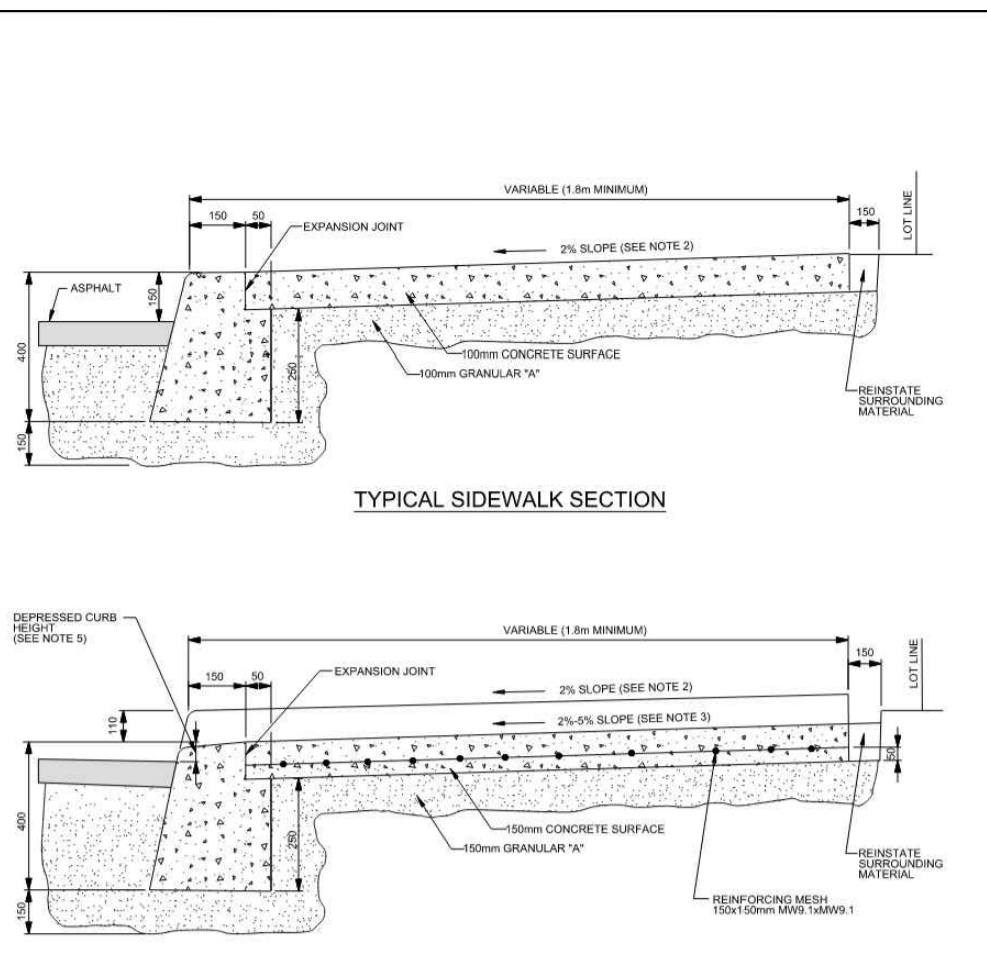

TYPICAL SIDEWALK SECTION

- NOTES:**
- ALL MEASUREMENTS ARE IN MILLIMETRES UNLESS OTHERWISE NOTED
 - THE MAXIMUM SLOPE IS NOT TO EXCEED 2%
 - FOR CURB RAMPS, SLOPE OF 2% TO 5% MAXIMUM 8%
 - EXPANSION AND DUMMY JOINTS AS PER SC3
 - DEPRESSED CURB HEIGHT - FOR PEDESTRIAN CURB RAMPS 0 TO 6 mm AND FOR PRIVATE ENTRANCES TO 13mm

CONCRETE BARRIER CURB WITH SIDEWALK
DATE: JAN 2003
REV: JULY 2025
DWG. No.: SC1.4

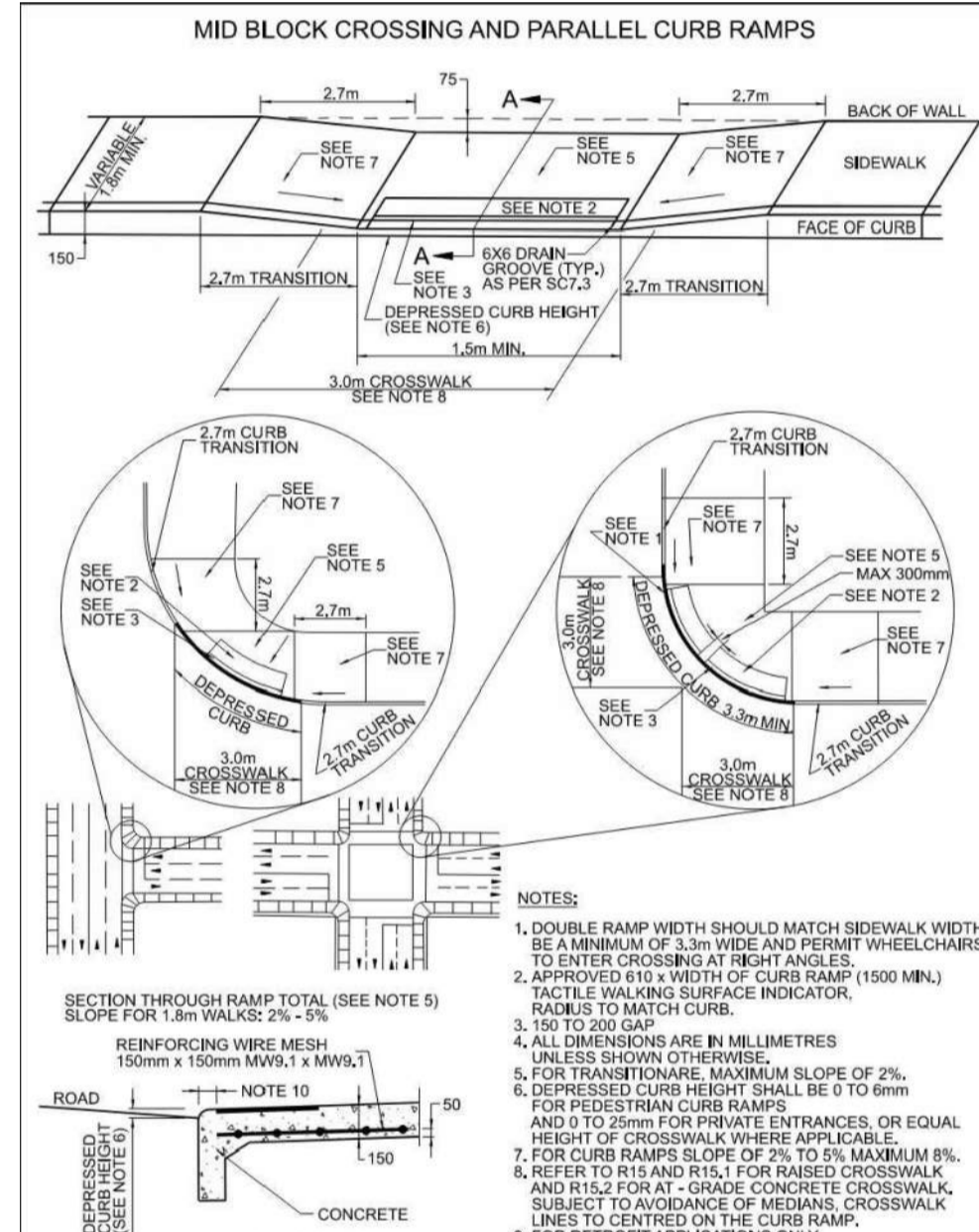

SECTION A-A
SECTION B-B
DATE: MAY 2001
REV: MARCH 2023
DWG. No.: SC6

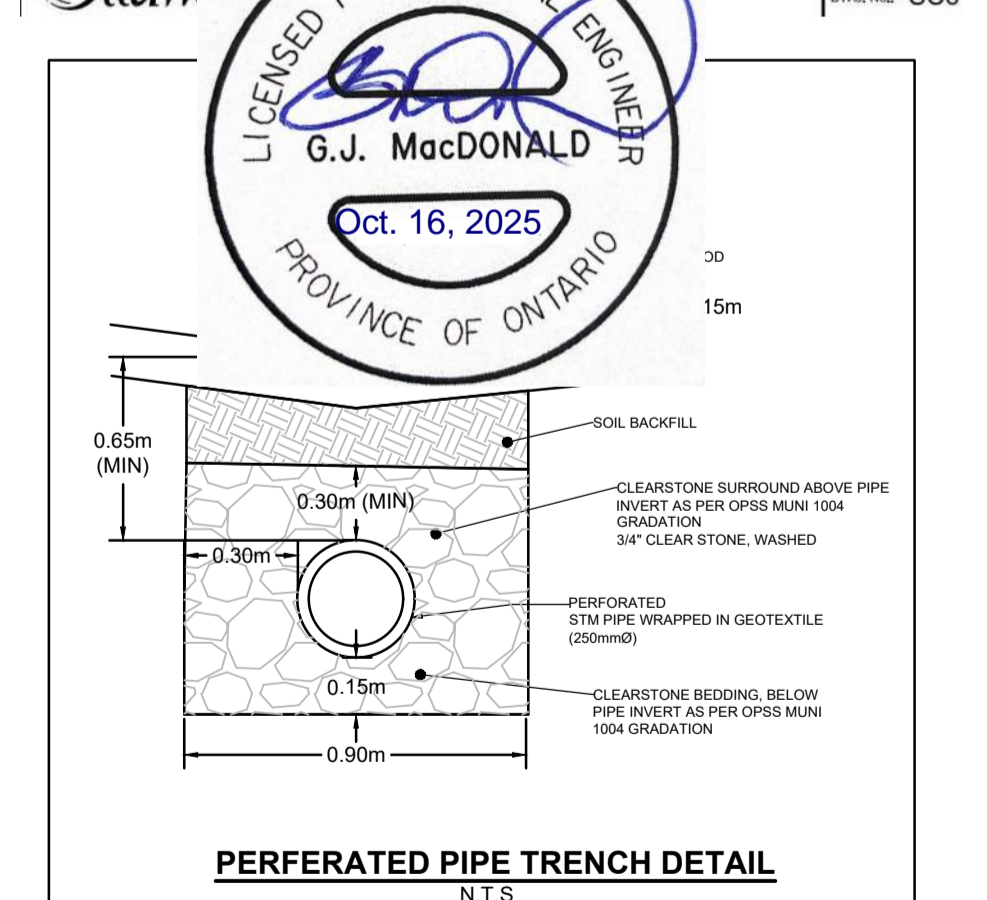

PERFORATED PIPE TRENCH DETAIL
N.T.S.

NOTE: THE POSITION OF ALL POLE LINES, CONDUITS, WATERMANS, SEWERS AND OTHER UNDERGROUND AND OVERGROUND UTILITIES AND STRUCTURES IS NOT NECESSARILY SHOWN ON THE CONTRACT DRAWINGS, AND WHERE SHOWN, THE ACCURACY OF THE POSITION OF SUCH UTILITIES AND STRUCTURES IS NOT GUARANTEED. BEFORE STARTING WORK, DETERMINE THE EXACT LOCATION OF ALL SUCH UTILITIES AND STRUCTURES AND ASSUME ALL LIABILITY FOR DAMAGE TO THEM.

NOT FOR CONSTRUCTION

No.	REVISION	DATE	BY
1.	ISSUED FOR SPA	OCT 16/2025	ARM

FOR REVIEW ONLY

DESIGN: ARM/AM
CHECKED: ARM
DRAWN: MF/AM
CHECKED: ARM
APPROVED: GJM

NOVATECH
Engineers, Planners & Landscape Architects
Suite 200, 240 Michael Cowpland Drive
Ottawa, Ontario, Canada K2M 1P6
Telephone: (613) 254-9643
Facsimile: (613) 254-5867
Website: www.novatech-eng.com

LOCATION: CITY OF OTTAWA, 2380 TENTH LINE
DRAWING NAME: NOTING AND DETAILS PLAN
PROJECT No.: 125079
REV: REV#1
DRAWING No.: 125079-ND

M:\2025\125079\CAD\civil\25079-ND.dwg, PLANS-A1, Oct 15, 2025, 4:45pm, amestwarp