

**EROSION AND SEDIMENT CONTROL NOTES:**

- THE CONTRACTOR SHALL IMPLEMENT BEST MANAGEMENT PRACTICES, TO PROVIDE FOR PROTECTION OF THE AREA DRAINAGE SYSTEM AND THE RECEIVING WATERCOURSE, DURING CONSTRUCTION ACTIVITIES. THE CONTRACTOR ACKNOWLEDGES THAT FAILURE TO IMPLEMENT APPROPRIATE EROSION AND SEDIMENT CONTROL MEASURES MAY BE SUBJECT TO PENALTIES IMPOSED BY ANY APPLICABLE REGULATORY AGENCY.
- 1) THE OWNER AGREES TO PREPARE AND IMPLEMENT AN EROSION AND SEDIMENT CONTROL PLAN TO THE SATISFACTION OF THE CITY OF OTTAWA, APPROPRIATE TO THE SITE CONDITIONS, PRIOR TO UNDERTAKING ANY SITE ALTERATIONS (FILLING, GRADING, REMOVAL OF VEGETATION, ETC.) AND DURING ALL PHASES OF SITE PREPARATION AND CONSTRUCTION IN ACCORDANCE WITH THE CURRENT BEST MANAGEMENT PRACTICES FOR EROSION AND SEDIMENT CONTROL, SUCH AS BUT NOT LIMITED TO INSTALLING FILTER CLOTHS ACROSS MANHOLE/CATCHBASIN LIDS TO PREVENT SEDIMENTS FROM ENTERING STRUCTURES AND INSTALL AND MAINTAIN A LIGHT DUTY SILT FENCE BARRIER AS REQUIRED.
  - 2) THE CONTRACTOR SHALL PLACE FILTER BAGS UNDER THE CATCHBASIN AND MANHOLE GRATES FOR THE DURATION OF CONSTRUCTION AND WILL REMAIN IN PLACE DURING ALL PHASES OF CONSTRUCTION.
  - 3) SILT FENCING FOR ENTIRE PERIMETER OF SITE, SHALL BE UTILIZED TO CONTROL EROSION FROM THE SITE DURING CONSTRUCTION.
  - 4) THE CONTRACTOR ACKNOWLEDGES THAT FAILURE TO IMPLEMENT EROSION AND SEDIMENT CONTROL MEASURES MAY BE SUBJECT TO PENALTIES IMPOSED BY ANY APPLICABLE REGULATORY AGENCY.
  - 5) PROVIDE MUD MATS AT ALL CONSTRUCTION ACCESS POINTS TO MINIMIZE SEDIMENT TRANSPORT OFFSITE.
  - 6) EROSION AND SEDIMENT CONTROL MEASURES MAY BE MODIFIED IN THE FIELD AT THE DISCRETION OF THE CITY OF OTTAWA SITE INSPECTOR OR CONSERVATION AUTHORITY.

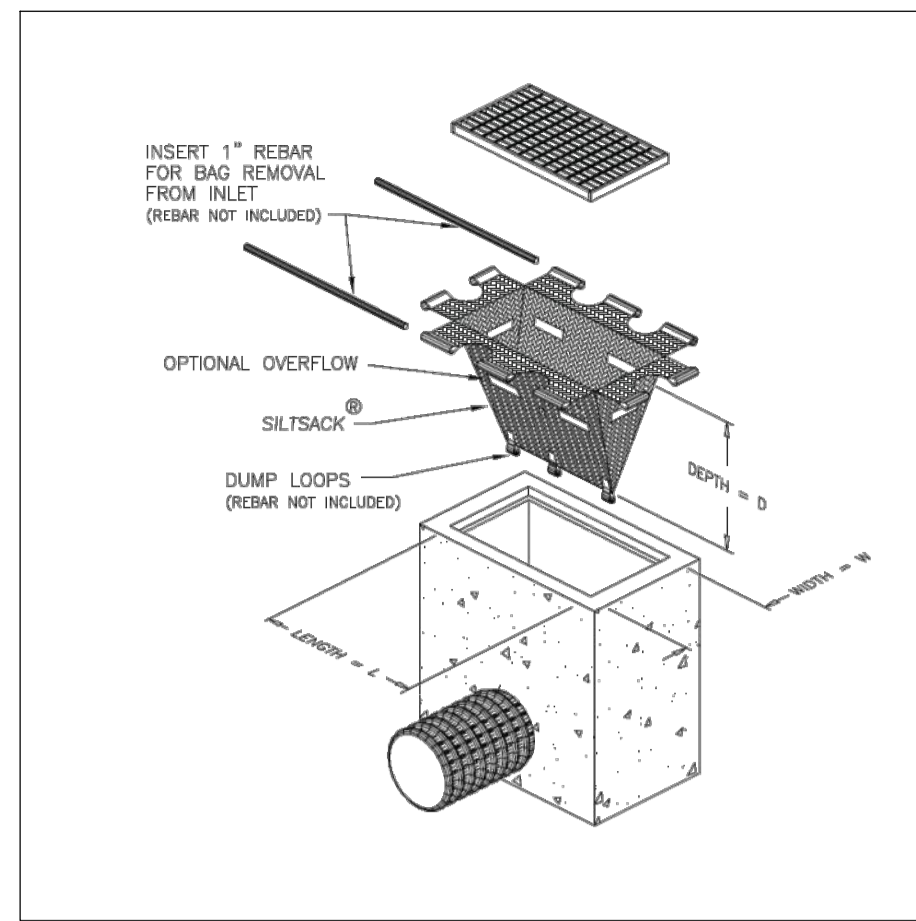

**FILTER BAG DETAIL**  
N.T.S.

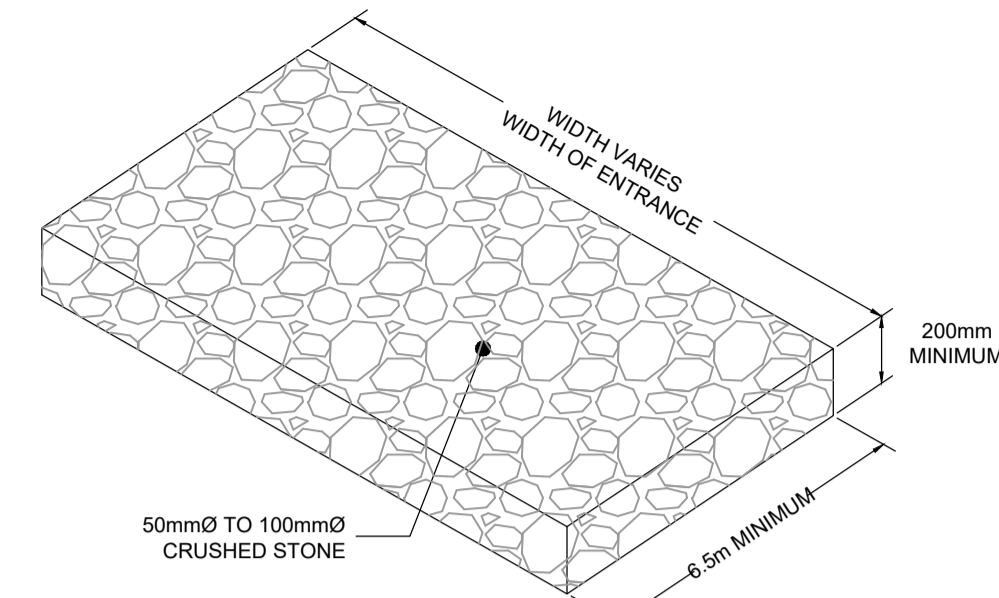

**MUD MAT DETAIL**  
NOT TO SCALE

NORTH

KEY PLAN  
N.T.S.

**LEGEND**

- PROPERTY LINE
- PROPOSED BARRIER CURB
- DC PROPOSED DEPRESSED CURB
- PROPOSED SWALE
- PROPOSED TACTILE WALKING SURFACE INDICATOR (TWSI)
- Y FIRE DEPARTMENT SIAMESE CONNECTION
- PROPOSED BUILDING ENTRANCE
- PROPOSED CATCHBASIN
- PROPOSED LANDSCAPE DRAIN (ELBOW/TEE)
- PROPOSED AREA DRAIN
- PROPOSED TRENCH DRAIN
- PROPOSED BIKE RACKS
- PROPOSED CROSSWALK PAINTING
- SAN MH ● PROPOSED SANITARY MANHOLE
- STM MH ○ PROPOSED STORM MANHOLE
- STM MH ○ PROPOSED CATCH BASIN MANHOLE
- STM MH ○ CD PROPOSED CATCH BASIN MANHOLE CW ICD
- PROPOSED FIRE HYDRANT
- PROPOSED VALVE AND VALVE BOX
- PROPOSED FILTER BAGS AT CATCHBASINS, CATCHBASIN MANHOLES AND TRENCHDRAINS
- M M PROPOSED MUD MAT
- LIGHT DUTY SILT FENCE (OPSD 219.110)
- EXISTING VALVE & VALVE BOX
- EXISTING FIRE HYDRANT
- SAN MH ● EXISTING SANITARY MANHOLE
- STM MH ○ EXISTING STORM MANHOLE
- CB 1 □ EXISTING CATCHBASIN
- LP EXISTING UTILITY POLE
- △ EXISTING ROAD SIGNAGE
- EXISTING DITCH/ BOTTOM OF SLOPE

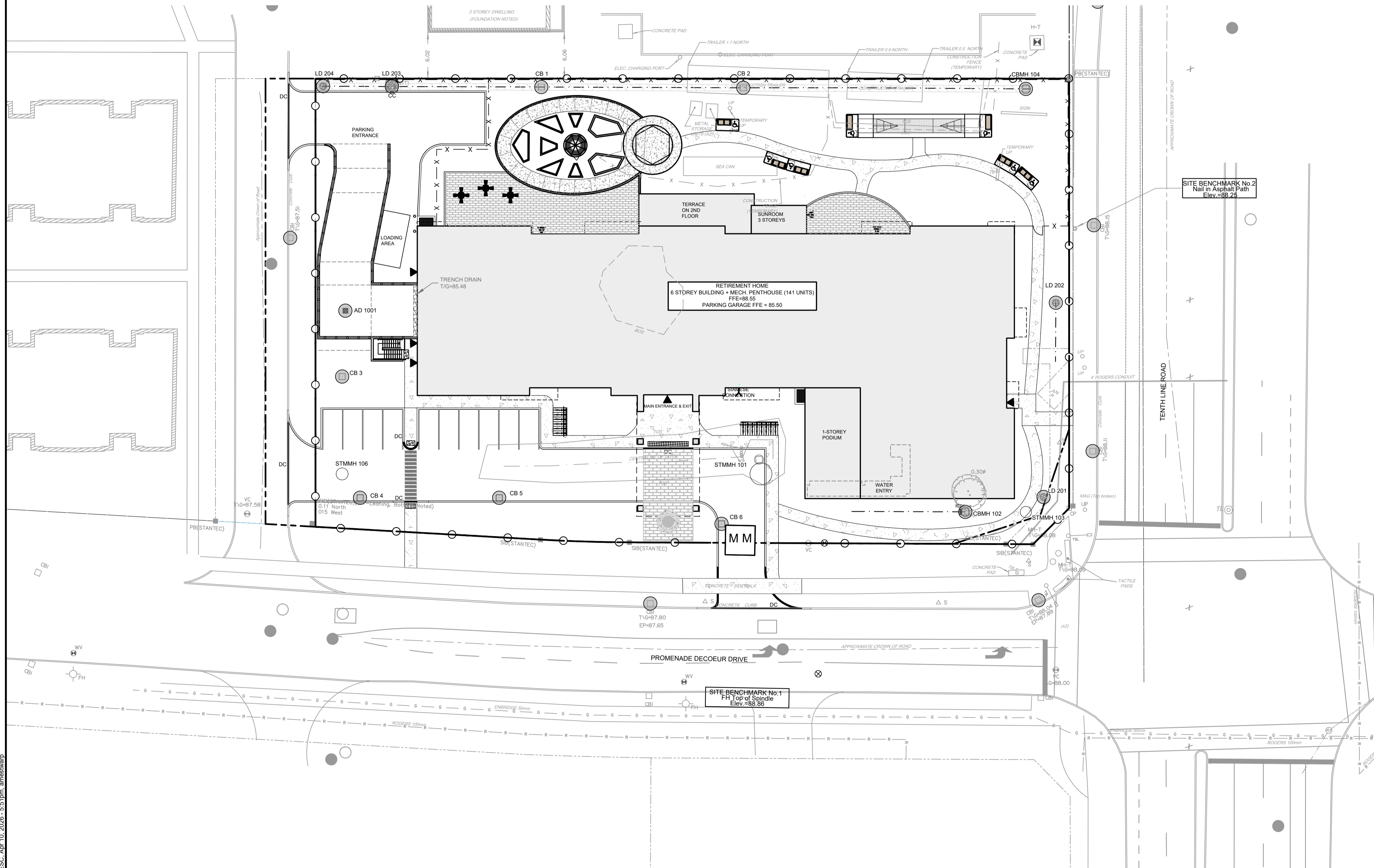

REFER TO 125079 - ND FOR ADDITIONAL NOTES & DETAILS

NOTE:  
THE POSITION OF ALL POLE LINES, CONDUITS, WATERMANS, SEWERS AND OTHER UNDERGROUND AND OVERGROUND UTILITIES AND STRUCTURES IS NOT NECESSARILY SHOWN ON THE CONTRACT DRAWINGS, AND WHERE SHOWN, THE ACCURACY OF THE POSITION OF SUCH UTILITIES AND STRUCTURES IS NOT GUARANTEED. BEFORE STARTING WORK, DETERMINE THE EXACT LOCATION OF ALL SUCH UTILITIES AND STRUCTURES AND ASSUME ALL LIABILITY FOR DAMAGE TO THEM.

**NOT FOR CONSTRUCTION**

No.	REVISION	DATE	BY
2.	REVISED PER CITY SUPPORTABILITY COMMENT	APRIL 17/2026	ARM
1.	ISSUED FOR SPA	OCT 16/2025	ARM

SCALE  
1:300

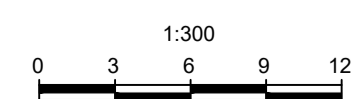

DESIGN	ARM/AM
CHECKED	ARM
DRAWN	MF/AM
CHECKED	ARM
APPROVED	GJM

FOR REVIEW ONLY



**NOVATECH**  
Engineers, Planners & Landscape Architects  
Suite 200, 240 Michael Cowpland Drive  
Ottawa, Ontario, Canada K2M 1P6  
Telephone (613) 254-9643  
Facsimile (613) 254-5867  
Website www.novatech-eng.com

LOCATION CITY OF OTTAWA 2380 TENTH LINE		PROJECT No.	125079
DRAWING NAME EROSION AND SEDIMENT CONTROL PLAN		REV	REV#2
		DRAWING No.	125079-ESC

M:\2025\125079\CAD\DWG\125079-ESC.dwg, ESC, Apr 10, 2026, 5:55 pm, amestwarp

PLANNING - 6/1/2025