

SUBJECT
4816 Bank Street Transportation Brief

TO
Patricia Warren, Fotenn

DATE
September 19, 2025

OUR REF
\147743 4816 Bank Street - Internal
Documents\6.0_Technical\6.23_Traffic\03_Reports

DEPARTMENT
Transportation Engineering

PROJECT NUMBER
147743

COPIES TO
Mike Boucher, Pheonix Homes

NAME
Ben Pascolo-Neveu, P.Eng.
ben.pascoloneveu@arcadis.com

Arcadis has been retained by Phoenix Homes to prepare a Transportation Brief in support of a proposed residential townhome and apartment development to be located at 4816 Bank Street in Ottawa, Ontario.

A TIA Screening Form was completed for the proposed development which provides the justification for the reduced scope of the study. The TIA Screening Form has been provided in **Appendix A**.

The following topics were discussed in this report:

1. Description of the proposed development
2. Context area details
3. Trip generation
4. Internal circulation review
5. Site access review
6. Parking review

Proposed Development

The proposed development is located west of Bank Street and south of Miikana Road in the community of Leitrim in Ottawa. It is anticipated that the proposed development will be constructed in a single phase.

Table 1 summarizes the proposed land uses included in this development.

Table 1 Land Uses

Land Use	Size
Back-to-Back Stacked Terrace Houses	132 units
Back-to-Back Townhomes	24 units
3-Storey Apartments	72 units
Total	228 units

The draft site plan for the proposed development is illustrated in **Figure 1** and has also been provided in **Appendix B**.

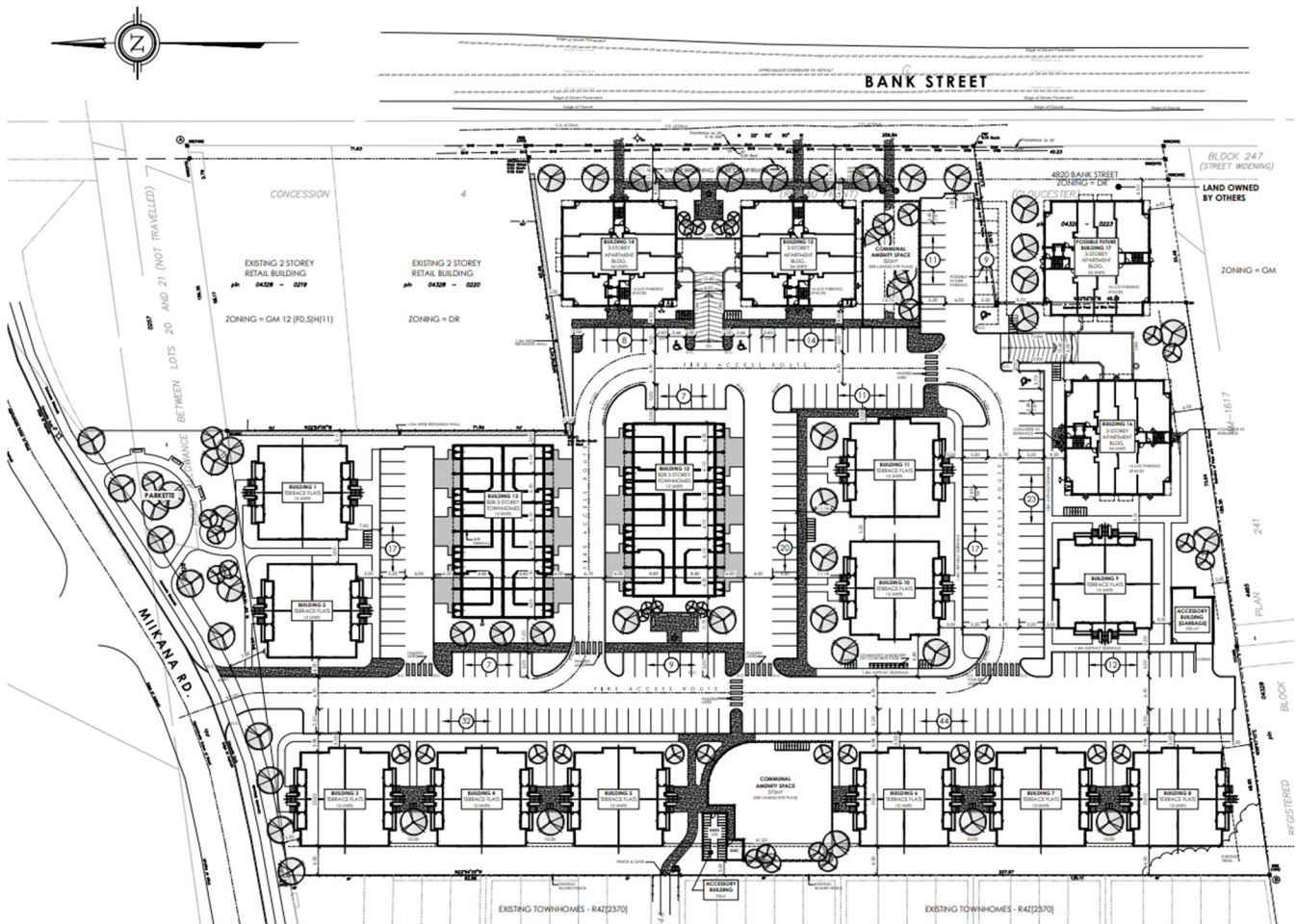

Figure 1 Proposed Development

Access to the site will be provided via a single all-movement access on Miikana Road, approximately 150m west of Bank Street. A total of 322 vehicle parking spaces and 102 bicycle parking spaces will be provided.

Context Area

The proposed development is located west of Bank Street and south of Miikana Road. Bank Street is currently being widened to four lanes between Leitrim Road and Miikana Road/Blais Road with completion anticipated for 2026¹. As part of this widening, the nearby Bank & Miikana/Blais intersection will be reconstructed as illustrated in **Figure 2** and sidewalks and cycle tracks will be provided on both sides of Bank Street north of Miikana Road/Blais Road.

¹ <https://ottawa.ca/en/city-hall/public-engagement/projects/bank-street-widening-and-reconstruction-south-leitrim-road-south-blais-road#>

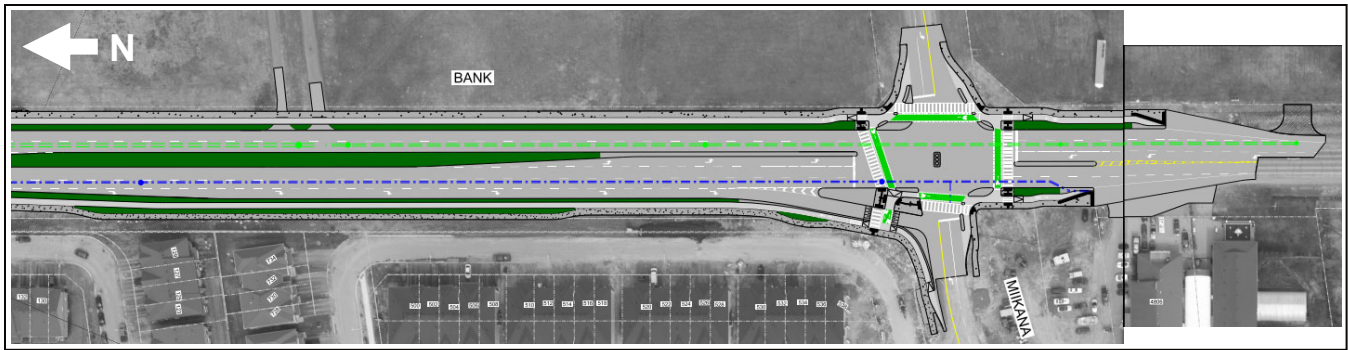

Figure 2 Bank Street Widening at Miikana Road/Blais Road

The Leitrim Master Transportation Study (MTS) (IBI Group, March 2017) has previously evaluated traffic operations at the Bank & Blais/Miikana intersection and concluded that the intersection will operate at an acceptable Level of Service (i.e., LOS ‘E’ or better) with the four-lane widening of Bank Street. The study determined that the worst-performing movement would operate at a v/c ratio of 0.87 by 2031. Given these results, the relatively low traffic generation of the proposed development, as described in the following section, and the fact that Bank Street is currently being widened to four lanes, it can be assumed that the Bank & Miikana/Blais intersection will have sufficient capacity to accommodate the long-term growth of the community, including the traffic generation associated with the proposed development, particularly as future development of this block was previously considered in the MTS results noted above.

There is currently no timeline for widening of Bank Street south of Miikana Road/Blais Road and adjacent to the site, based on the 2024 City-wide and Area-Specific Development Charges Background Study. As such, it is unknown when sidewalks and cycle tracks will be provided on the segment of Bank Street adjacent to the site.

Based on a recent traffic count of the Bank & Miikana/Blais intersection, two-way traffic volumes on Miikana Road are in the order of 300 vehicles per hour.

Trip Generation

The peak period person-trip generation of the site has been estimated using appropriate rates from the 2020 TRANS Trip Generation Manual. The resulting peak period (7-9:30am and 3:30-6pm) trip generation is summarized in **Table 2**.

Table 2 Peak Period Person Trips

Land Use	Size	AM Peak Period			PM Peak Period		
		In	Out	Total	In	Out	Total
Back-to-Back Stacked Terrace Houses	132 units	33	73	106	69	50	119
Back-to-Back Townhomes	24 units	6	13	19	13	9	22
3-Storey Apartments	72 units	18	40	58	38	27	65
Total	228 units	57	125	182	120	85	205

The existing mode share distributions for multi-unit high-rise² development in Leitrim/South Gloucester is summarized in **Table 3** below.

Table 3 Existing Mode Share Distributions

Travel Mode	AM Peak Period	PM Peak Period	Average
Auto Driver	50%	53%	51%
Auto Passenger	15%	17%	16%
Transit	25%	21%	23%
Bicycle	1%	1%	1%
Walk	9%	9%	9%

High-density development in this area of the city tends to have a relatively high non-auto mode share in the order of 50%. It is important to note that the mode share values presented above are based on the 2011 TRANS Origin-Destination Study. With the recent addition of LRT service at Leitrim Station it is anticipated that the transit mode share in the area will have since increased and continue to do so as the city-wide rapid transit network expands, although within the Study Area, many of these transit-trips may be park-and-ride trips that begin with an auto trip.

The peak period person-trips from **Table 2** have been subdivided by mode based on the existing mode share distributions from **Table 3** and converted to peak hour person-trips using the conversion factors from the 2020 TRANS Trip Generation Manual. The resulting peak hour person-trips by mode are summarized in **Table 4**.

Table 4 Peak Hour Trips by Mode

Travel Mode	AM Peak Period			PM Peak Period		
	In	Out	Total	In	Out	Total
Auto Driver	14	31	45	27	19	46
Auto Passenger	4	10	14	8	6	14
Transit	7	16	23	13	9	22
Bicycle	0	1	1	1	0	1
Walk	3	7	10	6	4	10
Total	28	65	93	55	38	93

The June 2023 revisions to the TIA Guidelines indicate that intersection capacity analysis and transit capacity analysis are only required for sites generating over 75 auto and transit trips, respectively. As such, the above trip generation results confirm that the reduced scope of this study is justified.

Furthermore, as discussed previously, the Leitrim MTS had concluded that the Bank & Miikana/Blais intersection will operate at an acceptable Level of Service (i.e., LOS 'E' or better) following the four-lane widening of Bank Street. Construction of the widened intersection is scheduled to be completed in the near future in 2026 and prior to the full buildout of the subject development. Based on the automobile trip generation volumes described above,

² The 2020 TRANS Trip Generation Manual defines high-rise as multi-unit housing with three or more storeys. All buildings within the proposed development will be three or more storeys in height.

it is not expected that the proposed development will trigger any capacity issues at a newly enlarged and reconstructed intersection, particularly as the Leitrim MTS analysis results provisioned for background growth for any unanticipated development. This further justifies the exclusion of intersection capacity analysis from this study.

Internal Circulation Review

A comprehensive pedestrian network is proposed within the site, including:

- Sidewalks on the east sides of both north-south drive aisles
- A sidewalk on the south side of one of the middle east-west drive aisle, and on both sides of the southernmost east-west drive aisle
- Sidewalk connections to the entrances of all of the back-to-back stacked terrace homes and apartment buildings
- Multiple sidewalk connections to existing and future sidewalks on Bank Street and Miikana Road
- A sidewalk connection to a public pathway which connects to Cedar Creek Drive. A chain link fence and gate will be installed at the western boundary of the site where the sidewalk connects to the public pathway

The TDM-Supportive Development Design and Infrastructure Checklist was completed and is provided in **Appendix C**.

The proposed development supports the City of Ottawa Official Plan's 15-Minute Neighbourhood. As illustrated in **Figure 3**, within a 15-minute walking distance of the site is the Findlay Creek Shopping Centre and the Cowan's Grove Shopping Plaza, a large number of parks, and two schools.



Figure 3 Areas within 15-Minute Walking Distance

The nearest bus stops to the site are located at the intersection of Kelly Farm Drive and Miikana Road and provide access to Route #294. This is just slightly beyond the 400m walking distance to transit target for the City of Ottawa.

Given the site's proximity to numerous amenities as well as transit, it is expected that many daily resident needs can be fulfilled by non-auto modes of transportation. To further encourage the use of sustainable travel modes, multi-modal information packages will be provided to first-time residents upon move-in. This is expected to help establish sustainable travel patterns from initial occupancy of the site.

The City of Ottawa's TDM Measures Checklist was completed for the proposed development and is provided in **Appendix C**.

Swept path analysis was undertaken to confirm the functionality of the site using a fire truck, a front-loading waste collection vehicle, and a medium single-unit (MSU) truck. The results of the swept path analysis are provided in **Appendix D** and indicate that there will be no issues with vehicle circulation.

Site Access Review

The Transportation Association of Canada (TAC) Geometric Design Guide for Canadian Roads indicates that the minimum intersection sight distance required for a single-unit truck to safely turn left from the site access is 160m. This requirement is based on an assumed design speed of 60 km/h (posted speed limit plus 10 km/h) for Miikana Road. As illustrated in **Figure 4** the minimum intersection sight distance requirement has been met.

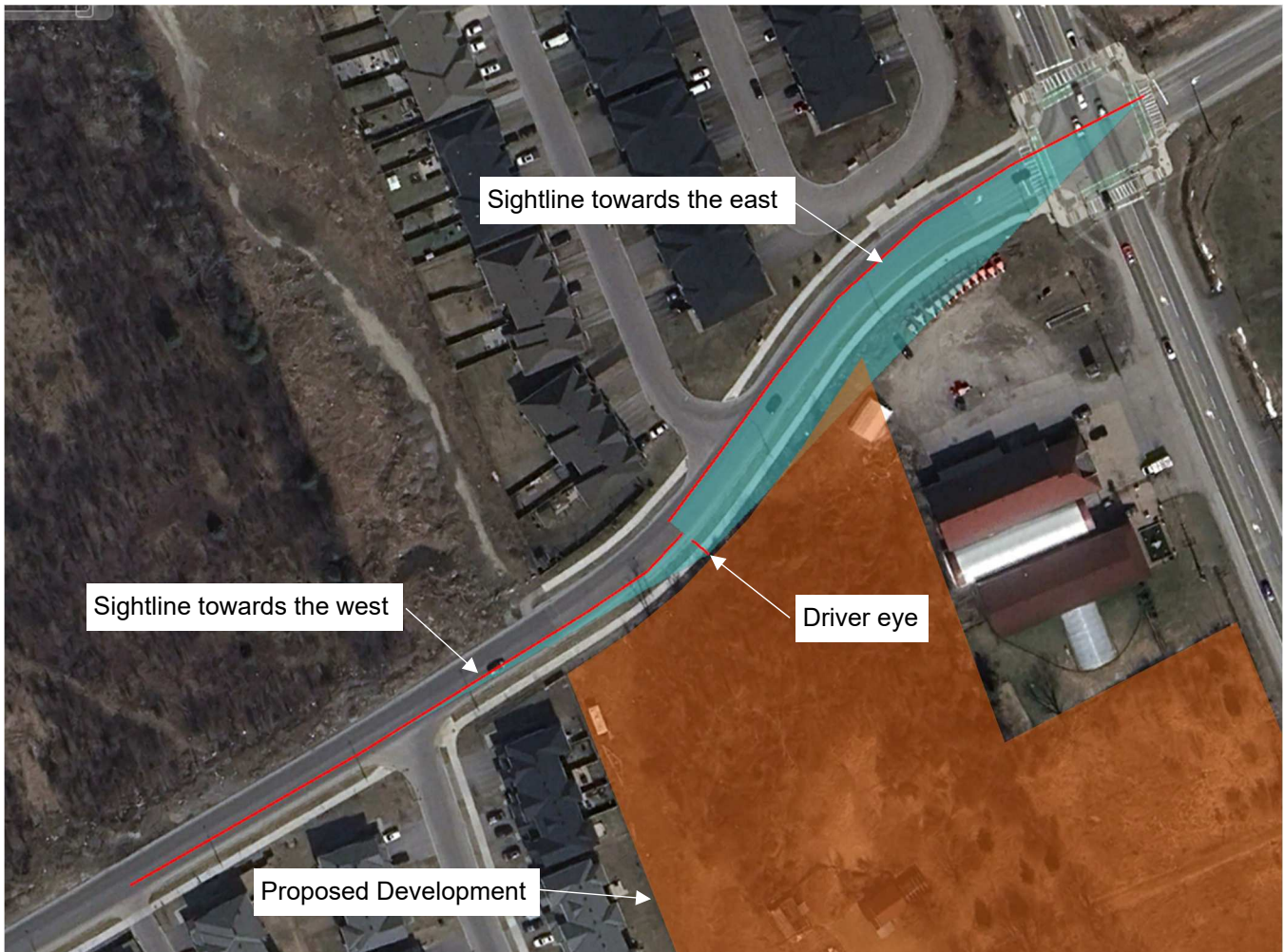

Figure 4 Intersection Sight Distance

The TAC guidelines further indicate that driveways on collector roads such as Miikana Road should have a minimum corner clearance of 55m from signalized intersections and have a minimum clear throat length of 15m. The proposed site access is located approximately 150m from the intersection of Bank Street and Miikana Road and therefore meets the minimum corner clearance requirement. From the edge of Miikana Road to the first point of potential conflict on the site, there is approximately 40m of space and therefore the minimum clear throat length requirement is also met.

The TAC guidelines state that “[f]or low volume roadways, such as locals and most collectors, the spatial relationship between driveways on opposite sides of the road is not a necessary design consideration.” As such, there are no concerns with respect to the offset between the proposed driveway and Hawkmere Way on the

opposite side of the road. Furthermore, there is limited likelihood for conflicting left-turns into this development and Hawkmere Way as traffic generation will be predominantly to/from the east via Bank Street. No cross traffic is expected.

The draft site plan has been reviewed for conformance with the Private Approach By-law (2003-447) with particular confirmation of the following items:

- **Width:** A private approach shall have a minimum width of 2.4m and a maximum width of 9.0m.
 - The private approach will be 6.7m wide. ✓
- **Quantity and Spacing of Private Approaches:** For sites with frontage between 46 and 150 metres, one (1) two-way private approach and two (2) one-way private approaches or two (2) two-way private approaches are permitted. Any two private approaches must be separated by at least 9.0m, although this can be reduced to 2.0m in the case of two one-way driveways. On lots that abut more than one roadway, these provisions apply to each frontage separately.
 - The site’s frontage on Miikana Road is approximately 105m therefore the single, two-way private approach is compliant with the by-law. ✓
- **Distance from Property Line:** Private approaches must be at least 3.0m from the abutting property line, however this requirement can be reduced to 0.3m provided that the access is a safe distance from the access serving the adjacent property, sight lines are adequate and that it does not create a traffic hazard.
 - The private approach is more than 3.0m from the property line. ✓

Parking Review

Table 5 summarizes the minimum number of parking spaces required based on the Zoning By-law (2008-250) and the number of spaces proposed.

Table 5 Parking Review

Land Use	Size	Type of Space	Parking Rate	Spaces Required	Spaces Proposed
Back-to-Back Townhomes	24 units	Resident	1.0 spaces/unit	24	48 ¹
		Visitor	0.2 spaces/unit	5	
Back-to-Back Stacked Townhomes	132 units	Resident	1.2 spaces/unit	158	184
		Visitor	0.2 spaces/unit	26	
		Bicycle	0.5 spaces/unit	66	66 ³
3-Storey Apartments	72 units	Resident	1.2 spaces/unit	86	90 ²
		Visitor	0.2 spaces/unit	14	
		Bicycle	0.5 spaces/unit	36	36 ³
Total Vehicle Spaces				313	322
Total Bicycle Spaces				102	102

¹ Includes one driveway space and one garage space per back-to-back townhouse.

² Includes 42 underground parking spaces and 48 surface parking spaces.

³ Bicycle parking is shared between all land uses and includes 32 spaces inside the accessory building and 70 outdoor spaces.

The results of the parking review indicate that the minimum parking requirements for the 3-storey apartment buildings are not met based on the current Zoning By-law (2008-250). It should be noted that the second draft of the new Zoning By-law was released on March 20, 2025, and features a number of revisions to the parking requirements outlined in the 2008 Zoning By-law (2008-250). The modifications include the elimination of minimum requirements for resident parking spaces and a reduction in the minimum visitor parking requirement to 0.1 spaces per unit. Furthermore, as the proposed development is located in Area C in Schedule A3 of the draft Zoning By-law, the visitor parking requirements do not apply to the first 12 dwelling units and the minimum visitor parking requirement cannot exceed 25 spaces. Under the draft Zoning By-law, the only requirement for the site would be to provide 22 visitor parking spaces. As such, the proposed parking supply exceeds the parking requirements of the future Zoning By-law.

The Institute of Transportation Engineers (ITE) Parking Generation Manual (6th Edition) was referenced to determine the anticipated parking demand generated by the proposed development. **Table 6** summarizes the estimated peak parking generation of the proposed development based on the number of units proposed. The analysis assumes that all stacked townhouse and apartment units will have a minimum of two bedrooms per unit.

Table 6 Parking Demand Review

Land Use	Size	Peak Parking Demand	Proposed Parking Capacity
Back-to-Back Stacked Terrace Houses	132 units	163 spaces	184 spaces
Back-to-Back Townhomes	24 units	35 spaces	48 spaces
3-Storey Apartments	72 units	89 spaces	90 spaces
Total		287 spaces	307 spaces

Note: ITE parking generation rates account for the parking demand generated by both residents and visitors. As such, the demand and capacity noted above includes the combined resident and visitor parking demand and capacity.

The results of the parking analysis indicate that sufficient parking capacity will be provided to accommodate the parking demand generated by the proposed development, provided visitor parking for the back-to-back stacked terrace houses and the 3-storey apartments are shared. As such, there is minimal risk of site-generated parking demand spilling over into the adjacent community and opportunities for parking off-site within close proximity to the development are limited in any case.

Relief from the By-law parking requirements is being sought to permit a resident parking rate of 1.0 spaces per unit. This would reduce the minimum parking requirement for the back-to-back stacked terrace houses and 3-storey apartment buildings to 158 spaces and 86 spaces, respectively, which is well within the parking capacity proposed.

The Zoning By-law specifies the following size requirements for parking facilities:

- Drive aisles must be a minimum of 6.0m in width.
- Parking spaces must be a minimum of 5.2m long and 2.6m wide

The proposed parking facility has been reviewed and meets the above requirements.

Conclusion

Based on the existing mode share distribution for the area, the proposed development is anticipated to generate up to 46 two-way vehicle-trips during the weekday morning and afternoon peak hours.

Access to the arterial road network will be provided via the Bank & Miikana/Blais intersection which is expected to be reconstructed and enlarged by 2026. Previous traffic studies have determined that the intersection is not expected to experience any intersection capacity issues once widened to four lanes. With consideration that there was provision of background growth included in the previous analysis to account for unanticipated growth through the application of an annual background growth rate and that the subject land was considered in the the Leitrim MTS, it is not expected that the low volume of peak hour automobile traffic that the site will generate would have any significant operational impact to the intersection that will be designed to its maximum practical size.

Swept path analysis has been completed to confirm the functionality of the site. The results of the analysis indicate that fire trucks, waste collection vehicles and moving trucks will be able to circulate within the site. Additionally, the site plan has been reviewed for conformance with applicable by-laws (e.g., Zoning and Private Approach By-laws) and technical standards/guidelines. The results of the review indicate that the proposed parking supply does not meet the minimum parking requirements of the current Zoning By-law. As such, relief is being sought to reduce the resident parking requirement to 1.0 spaces per unit. With consideration of the draft Zoning Bylaw which seeks to eliminate parking minimums on a city-wide basis, the proposed parking supply was verified as being appropriate based on ITE parking generation rates and local context.

Within a 15-minute walking distance of the site are a number of amenities including two schools, several parks, bus stops and shopping centres. As such, it is anticipated that many daily resident needs can be fulfilled by sustainable travel modes. To further encourage the use of sustainable travel modes, multi-modal information packages will be provided to first-time residents upon initial occupancy. Additionally, the site will include a number of sidewalk connections to adjacent streets to facilitate access to the public sidewalk network and transit facilities.

In conclusion, it is the overall opinion of Arcadis that the proposed development can be safely accommodated by the adjacent road network.



Patricia Warren
Fotenn
September 19, 2025

Appendix A: TIA Screening Form

City of Ottawa 2017 TIA Guidelines Screening Form

*Revised per City of Ottawa update to the TIA Guidelines, effective June 14, 2023

1. Description of Proposed Development

Municipal Address	4816 Bank Street
Description of Location	<p>The subject site is located west of Bank Street and south of Miikana Road in the Leitrim Community. To the south of the site is undeveloped land while to the west there are existing residential land uses.</p> 
Land Use Classification	Residential
Development Size (units)	144 back-to-back stacked terrace houses 44 back-to-back townhouses
Development Size (m ²)	N/A
Number of Accesses and Locations	One (1) full-movement access on Miikana Road
Phase of Development	Single phase
Buildout Year	TBD

If available, please attach a sketch of the development or site plan to this form.

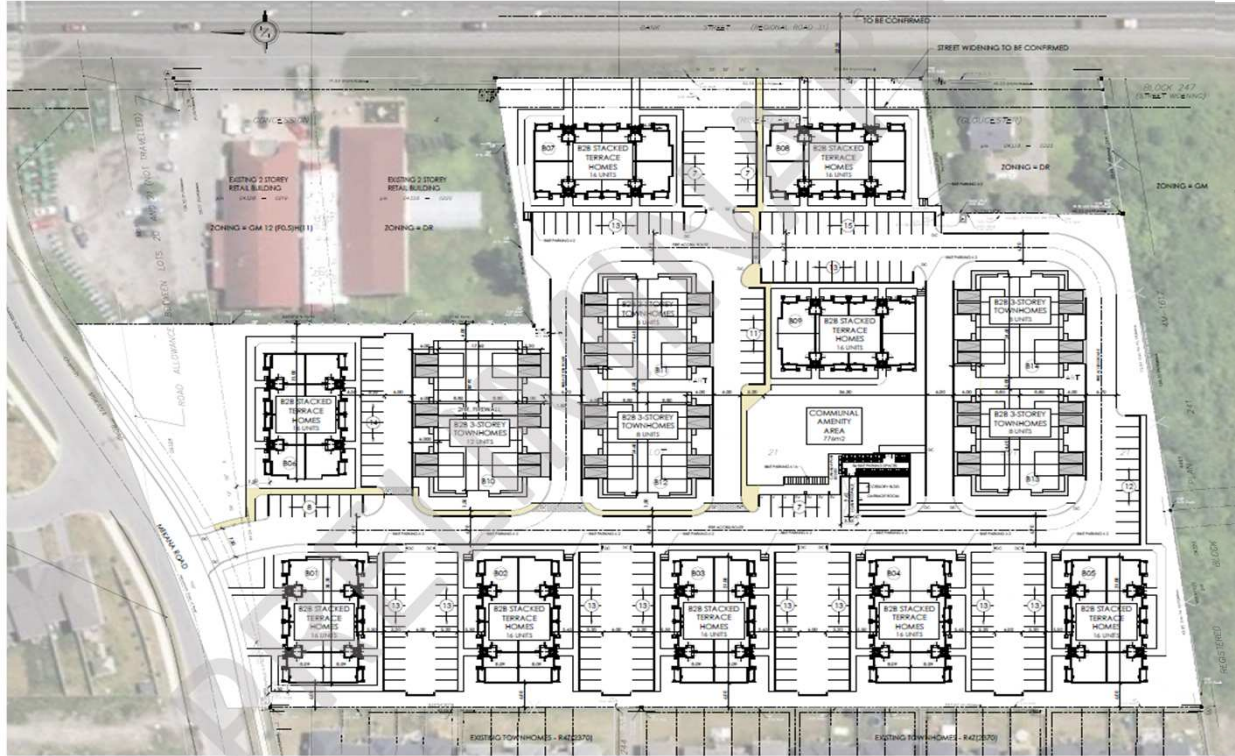

2. Trip Gen Trigger

Considering the Development's Land Use Type and Size (as filled out in the previous section), please refer to the Trip Generation Trigger checks below.

Land Use Type*	Minimum Development Size (60 person trips)	
Single-Detached ¹	60 units	
Multi-Use Family (Low-Rise) ¹	90 units	✓
Multi-Use Family (High-Rise) ¹	150 Units	
Office ²	1,400 m ²	
Industrial ²	7,000 m ²	
Fast-food restaurant or coffee shop ²	110 m ²	
Destination Retail ²	1,800 m ²	
Gas Station or convenience market ²	90 m ²	

*If the development has a land use type other than what is presented in the table above, estimates of person trip generation may be made based on average trip generation characteristics represented in the current edition of the Institute of Transportation Engineers (ITE) Trip Generation Manual.

¹ Table 2, Table 3 & Table 4 TRANS Trip Generation Summary Report

² ITE Trip Generation Manual 11.1 Ed.

Based on the above, the Trip Generation Trigger is satisfied.

3. Location Triggers

	Yes	No
Does the development propose a new driveway to a boundary street that is designated as part of the City's Transit Priority, Rapid Transit or Cross-Town Bikeways?		✓
Is the development in a Design Priority Area (DPA), Transit-oriented Development (TOD) zone or Hub?*		✓

*DPA and TOD are identified in the City of Ottawa Official Plan (DPA in Section 2.5.1 and Schedules A and B; TOD in Annex 6) See Chapter 4 for a list of City of Ottawa Planning and Engineering documents that support the completion of TIA.

Hubs are identified as Protected Major Transit Station Areas (PTMSAs) and identified in Schedule C1-Protected Major Transit Station Areas (PMTSAs).

Based on the above, the Location Trigger is not satisfied.

4. Safety Triggers		
	Yes	No
Are posted speed limits on a boundary street 80km/hr or greater?		✓
Are there any horizontal/vertical curvatures on a boundary street that limit sight lines at a proposed driveway?	✓	
Is the proposed driveway within the area of influence of an adjacent traffic signal or roundabout (i.e. within 300 m of intersection in rural conditions, or within 150 m of intersection in urban/suburban conditions?)	✓	
Is the proposed driveway within auxiliary lanes of an intersection?		✓
Does the proposed driveway make use of an existing median break that serves an existing site?		✓
Is there a documented history of traffic operations or safety concerns on the boundary streets within 500 m of the development?		✓
Does the development include a drive-thru facility?		✓

Based on the above, the Safety Trigger is satisfied.

5. Summary		
	Yes	No
Does the development satisfy the Trip Generation Trigger?	✓	
Does the development satisfy the Location Trigger?		✓
Does the development satisfy the Safety Trigger?	✓	

Although the Trip Generation and Safety triggers are met, it is not expected that a full TIA will be necessary. The Bank Street corridor is currently undergoing a four-lane widening between Leitrim Road and Miikana Road/Blais Road and it is expected that this roadway widening will be providing sufficient capacity to accommodate traffic demand for development in Leitrim that is within the existing urban boundary. As such, a reduced-scope TIA in the form of a Transportation Brief will be prepared which focuses on the site access (i.e., sightlines, corner clearances, etc.) and site configuration (i.e., parking review, swept path analysis, etc.) to address the safety-related concerns identified above. The scope of study will therefore not require a review of existing traffic volumes in the vicinity of the site nor include any intersection capacity analyses.

Patricia Warren
Fotenn
September 19, 2025

Appendix B: Site Plan

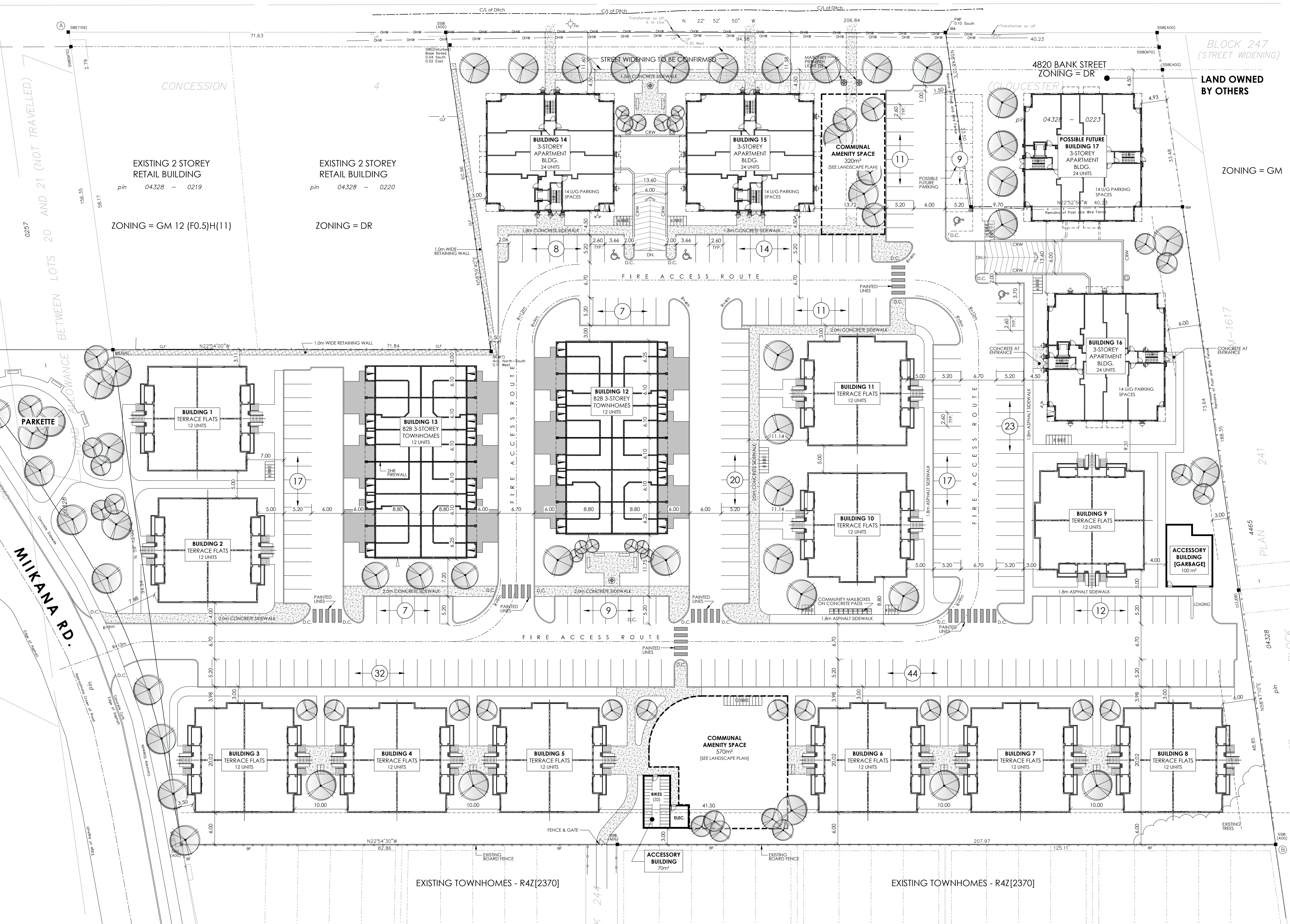
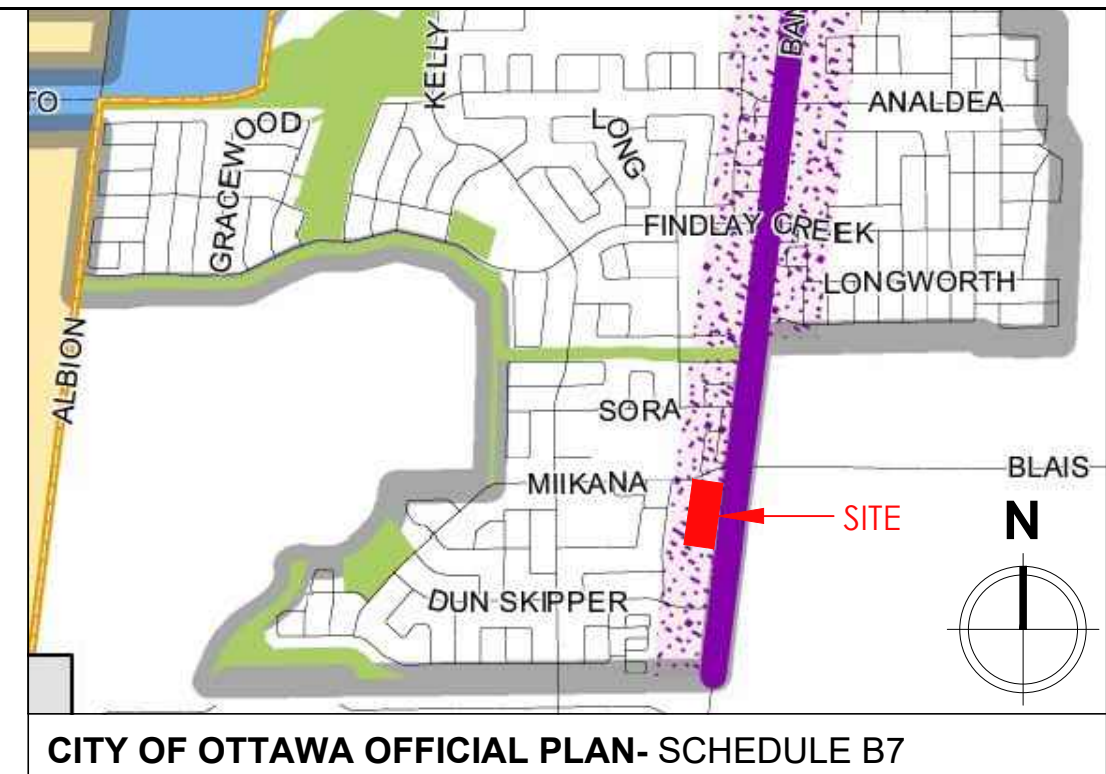
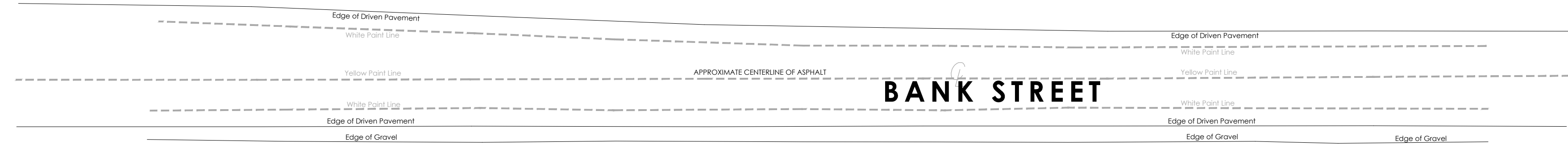
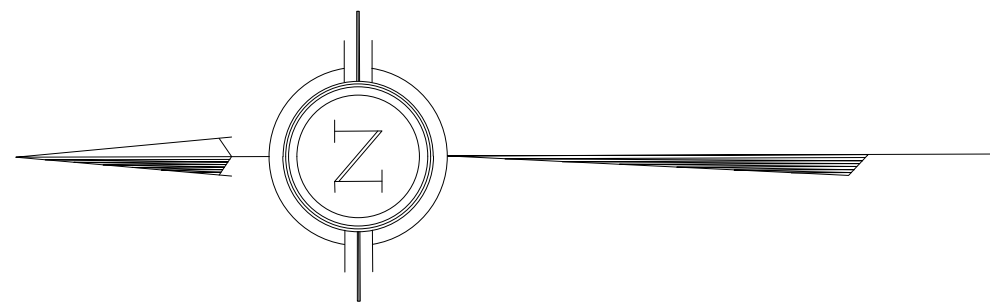

SITE INFORMATION:
 SITE AREA = 2.4352ha (6.51 Acres.) NOT INCLUDING 4820 BANK ST.
 ZONING: DR

UNIT COUNTS:

BUILDING	UNIT TYPE	COUNT
BUILDING 1=	B2B STACKED TERRACE FLATS	12 UNITS
BUILDING 2=	B2B STACKED TERRACE FLATS	12 UNITS
BUILDING 3=	B2B STACKED TERRACE FLATS	12 UNITS
BUILDING 4=	B2B STACKED TERRACE FLATS	12 UNITS
BUILDING 5=	B2B STACKED TERRACE FLATS	12 UNITS
BUILDING 6=	B2B STACKED TERRACE FLATS	12 UNITS
BUILDING 7=	B2B STACKED TERRACE FLATS	12 UNITS
BUILDING 8=	B2B STACKED TERRACE FLATS	12 UNITS
BUILDING 9=	B2B STACKED TERRACE FLATS	12 UNITS
BUILDING 10=	B2B STACKED TERRACE FLATS	12 UNITS
BUILDING 11=	B2B STACKED TERRACE FLATS	12 UNITS
BUILDING 12=	B2B 3-STORY TOWNHOMES	12 UNITS
BUILDING 13=	B2B 3-STORY TOWNHOMES	12 UNITS
BUILDING 14=	3-STORY APARTMENT BUILDING	24 UNITS
BUILDING 15=	3-STORY APARTMENT BUILDING	24 UNITS
BUILDING 16=	3-STORY APARTMENT BUILDING (POSSIBLE FUTURE)	24 UNITS (NOT INCLUDED)
BUILDING 17=	3-STORY APARTMENT BUILDING (POSSIBLE FUTURE)	24 UNITS (NOT INCLUDED)
TOTAL =		132 UNITS

TOTAL ALL UNITS = 228 UNITS (NOT INCLUDING POSSIBLE FUTURE UNITS)

PARKING REQUIREMENTS: SCHEDULE 1A AREA 'C'

BUILDINGS 1-11 : B2B STACKED TERRACE HOMES (132 UNITS)
 PARKING REQUIRED= 1.2/d.u. + 0.2/d.u. VISITORS = 158 + 26 = 184 SPACES (SURFACE)
 PARKING PROVIDED = 184 SPACES (SURFACE)
 1.4 SPACES/ D.U.

BUILDINGS 12-13 : B2B 3-STORY TOWNHOMES (24 UNITS)
 PARKING REQUIRED= 1.0/d.u. + 0.2/d.u. VISITORS = 28 + 6 = 34 SPACES (DRIVEWAY & GARAGE)
 PARKING PROVIDED = 48 SPACES (DRIVEWAY & GARAGE)

BUILDINGS 14-16 : 3-STORY APARTMENT BUILDINGS (72 UNITS)
 PARKING REQUIRED 1.2/d.u. + 0.2/d.u. VISITORS = 86 + 14 = 100 SPACES
 PARKING PROVIDED = 90 SPACES (42 I/U/G + 48 SURFACE)
 1.25 SPACES/ D.U. (NOT INCLUDING POSSIBLE FUTURE)

BICYCLE PARKING REQUIREMENTS:
 BICYCLE PARKING REQUIRED= 0.5/d.u. x 204 d.u. = 102 SPACES
 BICYCLE PARKING PROVIDED = 102 SPACES (32 INDOOR + 70 SURFACE)

ALL EXTERIOR BIKE SPACES ARE 0.60m X 1.80m HORIZONTAL w/ MIN. 1.50m ACCESS ISLE.
 ALL INTERIOR BIKE SPACES ARE 0.50m X 1.50m VERTICAL w/ MIN. 1.50m ACCESS ISLE.
 PROVIDE FIXED PARKING RACKS FOR ALL BIKE SPACES.

AMENITY SPACE REQUIREMENTS:
 AMENITY SPACE REQUIRED = 6m²/d.u. x 204 d.u. = 1,224m²
 SOR COMMUNAL AMENITY AREA REQUIRED = 612m²
 COMMUNAL AMENITY AREA PROVIDED = 890m²
 PRIVATE AMENITY AREA PROVIDED = 816m² (4m²/BALCONY/d.u.)
 TOTAL AMENITY AREA PROVIDED = 1,706m²

SITE PLAN TO BE READ IN CONJUNCTION WITH:
 - SITE SERVICING AND GRADING PLAN PREPARED BY:
 - LANDSCAPING PLAN PREPARED BY: JAMES B. LENNOX AND ASSOCIATES INC.
 - COMPOSITE UTILITY PLAN PREPARED BY:

LEGEND/ ABBREVIATIONS:

D.C.	DEPRESSED CURB	⊙	GAS METERS LOCATION	⊙	LS	LIGHT STANDARD
CRW	CONCRETE RETAINING WALL	—	WATER/SANITARY CONNECTION	—	—	WALL MOUNTED LIGHT FIXTURE
HWL	WINDROUFT HOOD	—	STORM CONNECTION	—	—	POLE LIGHT
TWS	TACTILE WALKING SURFACE INDICATOR	—	SIAMENSE CONNECTIONS	—	—	TRANSFORMER
CONC.	CONCRETE	—	—	—	—	—
ASPH.	ASPHALT	—	—	—	—	—
HYD.	HYDRO (METER LOCATION)	—	—	—	—	—



SITE BOUNDARIES DERIVED FROM:
 PLAN OF SURVEY OF
**PART OF LOT 21
 CONCESSION 4 (RIDEAU FRONT) (GLOUCESTER)**
 CITY OF OTTAWA
 SURVEYED BY ANNIS, O'SULLIVAN, VOLLEBEK LTD.
 DATED: AUGUST 26, 2024.

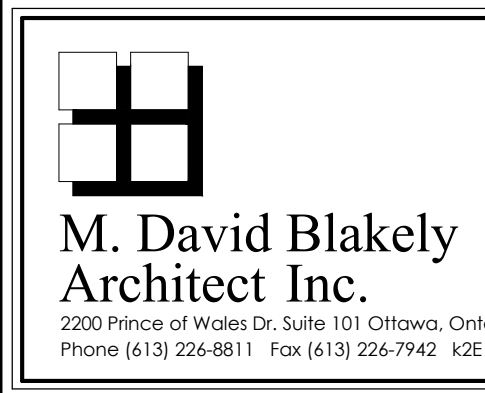

GENERAL NOTES:
 1. THE CONTRACTOR IS RESPONSIBLE FOR CHECKING AND VERIFYING ALL DIMENSIONS. ANY DISCREPANCY MUST BE REPORTED TO M. DAVID BLAKELY ARCHITECT INC.
 2. ALL WORK AND MATERIALS TO BE IN COMPLIANCE WITH ALL CODES, REGULATIONS, & BY-LAWS.
 3. ADDITIONAL DRAWINGS MAY BE ISSUED FOR CLARIFICATION TO ASSIST THE PROPER EXECUTION OF WORK. SUCH DRAWINGS WILL HAVE THE SAME HEADING AND PRENT AS IF THEY WERE INCLUDED WITH THE PLANS IN CONTRACT DOCUMENTS
 4. DO NOT SCALE DRAWINGS.
 5. THIS DRAWING SHALL NOT BE USED OR COPIED WITHOUT THE AUTHORIZATION OF THE ARCHITECT & THIS DRAWING SHALL NOT BE USED FOR PERMIT OR CONSTRUCTION UNLESS THE DRAWING BEARS THE ARCHITECT'S SEAL AND SIGNATURE.

OWNER: PHOENIX HOMES
 18A BENTLEY AVE.
 OTTAWA, ON K2E 6T8
 (613) 723-9227

ARCHITECT: M. DAVID BLAKELY ARCHITECT INC.
 2200 PRINCE OF WALES DR., SUITE 101
 OTTAWA, ON K2E 4Z7
 (613) 226-8811

CIVIL ENGINEER: ARCADIS
 333 PRESTON STREET #400
 OTTAWA, ON K1S 5N4
 (613) 225-1311

LANDSCAPE ARCHITECT: JAMES B. LENNOX AND ASSOCIATES INC.
 3302 CARLING AVE.
 NEPEAN, ON K2H 5A8
 (613) 722-5168

SURVEYOR: ANNIS O'SULLIVAN VOLLEBEK LTD.
 14 CONCORSE GATE, SUITE 500
 NEPEAN, ON K2E 7S6
 (613) 727-0500

REVISIONS

No.	DATE	DESCRIPTION	INT.
1.	04/09/24	FOR REVIEW	KB
2.	28/01/25	REVISED AS PER CITY COMMENTS/DCR PHOENIX	MB
3.	16/07/25	REVISED AS PER CLIENT/ FOR REVIEW	MB

REVISIONS

No.	DATE	DESCRIPTION	INT.
1.	04/09/24	FOR REVIEW	KB
2.	28/01/25	REVISED AS PER CITY COMMENTS/DCR PHOENIX	MB
3.	16/07/25	REVISED AS PER CLIENT/ FOR REVIEW	MB

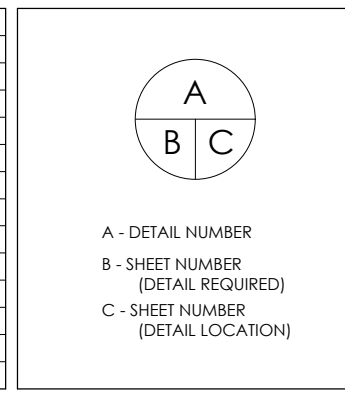

PROJECT: 4816 BANK STREET
 PLANNED UNIT DEVELOPMENT
 OTTAWA, ONTARIO

CLIENT: PHOENIX HOMES
 18A Bentley Ave Ottawa, ON K2E 6T8

DRAWING TITLE: SITE PLAN

DATE: SEPT. 2024

SCALE: 1 : 400

DRAWN BY: KB

CHECKED: MDB

SHEET NO.: SP1

Patricia Warren
Fotenn
September 19, 2025

Appendix C: Transportation Demand Management

TDM-Supportive Development Design and Infrastructure Checklist:
Residential Developments (multi-family or condominium)

Legend	
REQUIRED	The Official Plan or Zoning By-law provides related guidance that must be followed
BASIC	The measure is generally feasible and effective, and in most cases would benefit the development and its users
BETTER	The measure could maximize support for users of sustainable modes, and optimize development performance

TDM-supportive design & infrastructure measures: <i>Residential developments</i>		Check if completed & add descriptions, explanations or plan/drawing references
1. WALKING & CYCLING: ROUTES		
1.1 Building location & access points		
BASIC	1.1.1 Locate building close to the street, and do not locate parking areas between the street and building entrances	<input checked="" type="checkbox"/>
BASIC	1.1.2 Locate building entrances in order to minimize walking distances to sidewalks and transit stops/stations	<input checked="" type="checkbox"/>
BASIC	1.1.3 Locate building doors and windows to ensure visibility of pedestrians from the building, for their security and comfort	<input checked="" type="checkbox"/>
1.2 Facilities for walking & cycling		
REQUIRED	1.2.1 Provide convenient, direct access to stations or major stops along rapid transit routes within 600 metres; minimize walking distances from buildings to rapid transit; provide pedestrian-friendly, weather-protected (where possible) environment between rapid transit accesses and building entrances; ensure quality linkages from sidewalks through building entrances to integrated stops/stations <i>(see Official Plan policy 4.3.3)</i>	<input type="checkbox"/> N/A - No rapid transit near site
REQUIRED	1.2.2 Provide safe, direct and attractive pedestrian access from public sidewalks to building entrances through such measures as: reducing distances between public sidewalks and major building entrances; providing walkways from public streets to major building entrances; within a site, providing walkways along the front of adjoining buildings, between adjacent buildings, and connecting areas where people may congregate, such as courtyards and transit stops; and providing weather protection through canopies, colonnades, and other design elements wherever possible <i>(see Official Plan policy 4.3.12)</i>	<input checked="" type="checkbox"/>

TDM-supportive design & infrastructure measures: <i>Residential developments</i>		Check if completed & add descriptions, explanations or plan/drawing references
REQUIRED	1.2.3 Provide sidewalks of smooth, well-drained walking surfaces of contrasting materials or treatments to differentiate pedestrian areas from vehicle areas, and provide marked pedestrian crosswalks at intersection sidewalks (<i>see Official Plan policy 4.3.10</i>)	<input checked="" type="checkbox"/>
REQUIRED	1.2.4 Make sidewalks and open space areas easily accessible through features such as gradual grade transition, depressed curbs at street corners and convenient access to extra-wide parking spaces and ramps (<i>see Official Plan policy 4.3.10</i>)	<input checked="" type="checkbox"/>
REQUIRED	1.2.5 Include adequately spaced inter-block/street cycling and pedestrian connections to facilitate travel by active transportation. Provide links to the existing or planned network of public sidewalks, multi-use pathways and on-road cycle routes. Where public sidewalks and multi-use pathways intersect with roads, consider providing traffic control devices to give priority to cyclists and pedestrians (<i>see Official Plan policy 4.3.11</i>)	<input checked="" type="checkbox"/>
BASIC	1.2.6 Provide safe, direct and attractive walking routes from building entrances to nearby transit stops	<input type="checkbox"/>
BASIC	1.2.7 Ensure that walking routes to transit stops are secure, visible, lighted, shaded and wind-protected wherever possible	<input type="checkbox"/>
BASIC	1.2.8 Design roads used for access or circulation by cyclists using a target operating speed of no more than 30 km/h, or provide a separated cycling facility	<input type="checkbox"/>
1.3 Amenities for walking & cycling		
BASIC	1.3.1 Provide lighting, landscaping and benches along walking and cycling routes between building entrances and streets, sidewalks and trails	<input type="checkbox"/>
BASIC	1.3.2 Provide wayfinding signage for site access (where required, e.g. when multiple buildings or entrances exist) and egress (where warranted, such as when directions to reach transit stops/stations, trails or other common destinations are not obvious)	<input type="checkbox"/>

TDM-supportive design & infrastructure measures: <i>Residential developments</i>		Check if completed & add descriptions, explanations or plan/drawing references
2. WALKING & CYCLING: END-OF-TRIP FACILITIES		
2.1 Bicycle parking		
REQUIRED	2.1.1 Provide bicycle parking in highly visible and lighted areas, sheltered from the weather wherever possible (see <i>Official Plan policy 4.3.6</i>)	<input checked="" type="checkbox"/>
REQUIRED	2.1.2 Provide the number of bicycle parking spaces specified for various land uses in different parts of Ottawa; provide convenient access to main entrances or well-used areas (see <i>Zoning By-law Section 111</i>)	<input checked="" type="checkbox"/>
REQUIRED	2.1.3 Ensure that bicycle parking spaces and access aisles meet minimum dimensions; that no more than 50% of spaces are vertical spaces; and that parking racks are securely anchored (see <i>Zoning By-law Section 111</i>)	<input checked="" type="checkbox"/>
BASIC	2.1.4 Provide bicycle parking spaces equivalent to the expected number of resident-owned bicycles, plus the expected peak number of visitor cyclists	<input type="checkbox"/>
2.2 Secure bicycle parking		
REQUIRED	2.2.1 Where more than 50 bicycle parking spaces are provided for a single residential building, locate at least 25% of spaces within a building/structure, a secure area (e.g. supervised parking lot or enclosure) or bicycle lockers (see <i>Zoning By-law Section 111</i>)	<input checked="" type="checkbox"/>
BETTER	2.2.2 Provide secure bicycle parking spaces equivalent to at least the number of units at condominiums or multi-family residential developments	<input type="checkbox"/>
2.3 Bicycle repair station		
BETTER	2.3.1 Provide a permanent bike repair station, with commonly used tools and an air pump, adjacent to the main bicycle parking area (or secure bicycle parking area, if provided)	<input type="checkbox"/>
3. TRANSIT		
3.1 Customer amenities		
BASIC	3.1.1 Provide shelters, lighting and benches at any on-site transit stops	<input type="checkbox"/>
BASIC	3.1.2 Where the site abuts an off-site transit stop and insufficient space exists for a transit shelter in the public right-of-way, protect land for a shelter and/or install a shelter	<input type="checkbox"/>
BETTER	3.1.3 Provide a secure and comfortable interior waiting area by integrating any on-site transit stops into the building	<input type="checkbox"/>

TDM-supportive design & infrastructure measures: <i>Residential developments</i>		Check if completed & add descriptions, explanations or plan/drawing references
4. RIDESHARING		
4.1 Pick-up & drop-off facilities		
BASIC	4.1.1 Provide a designated area for carpool drivers (plus taxis and ride-hailing services) to drop off or pick up passengers without using fire lanes or other no-stopping zones	<input type="checkbox"/>
5. CARSHARING & BIKESHARING		
5.1 Carshare parking spaces		
BETTER	5.1.1 Provide up to three carshare parking spaces in an R3, R4 or R5 Zone for specified residential uses (see <i>Zoning By-law Section 94</i>)	<input type="checkbox"/>
5.2 Bikeshare station location		
BETTER	5.2.1 Provide a designated bikeshare station area near a major building entrance, preferably lighted and sheltered with a direct walkway connection	<input type="checkbox"/>
6. PARKING		
6.1 Number of parking spaces		
REQUIRED	6.1.1 Do not provide more parking than permitted by zoning, nor less than required by zoning, unless a variance is being applied for	<input checked="" type="checkbox"/>
BASIC	6.1.2 Provide parking for long-term and short-term users that is consistent with mode share targets, considering the potential for visitors to use off-site public parking	<input type="checkbox"/>
BASIC	6.1.3 Where a site features more than one use, provide shared parking and reduce the cumulative number of parking spaces accordingly (see <i>Zoning By-law Section 104</i>)	<input type="checkbox"/>
BETTER	6.1.4 Reduce the minimum number of parking spaces required by zoning by one space for each 13 square metres of gross floor area provided as shower rooms, change rooms, locker rooms and other facilities for cyclists in conjunction with bicycle parking (see <i>Zoning By-law Section 111</i>)	<input type="checkbox"/>
6.2 Separate long-term & short-term parking areas		
BETTER	6.2.1 Provide separate areas for short-term and long-term parking (using signage or physical barriers) to permit access controls and simplify enforcement (i.e. to discourage residents from parking in visitor spaces, and vice versa)	<input type="checkbox"/>

TDM Measures Checklist:
Residential Developments (multi-family, condominium or subdivision)

Legend	
BASIC	The measure is generally feasible and effective, and in most cases would benefit the development and its users
BETTER	The measure could maximize support for users of sustainable modes, and optimize development performance
★	The measure is one of the most dependably effective tools to encourage the use of sustainable modes

TDM measures: <i>Residential developments</i>		Check if proposed & add descriptions
1. TDM PROGRAM MANAGEMENT		
1.1 Program coordinator		
BASIC	★ 1.1.1	Designate an internal coordinator, or contract with an external coordinator <input type="checkbox"/>
1.2 Travel surveys		
BETTER	1.2.1	Conduct periodic surveys to identify travel-related behaviours, attitudes, challenges and solutions, and to track progress <input type="checkbox"/>
2. WALKING AND CYCLING		
2.1 Information on walking/cycling routes & destinations		
BASIC	2.1.1	Display local area maps with walking/cycling access routes and key destinations at major entrances (<i>multi-family, condominium</i>) <input type="checkbox"/>
2.2 Bicycle skills training		
BETTER	2.2.1	Offer on-site cycling courses for residents, or subsidize off-site courses <input type="checkbox"/>

TDM measures: <i>Residential developments</i>		Check if proposed & add descriptions
3. TRANSIT		
3.1 Transit information		
BASIC	3.1.1 Display relevant transit schedules and route maps at entrances (<i>multi-family, condominium</i>)	<input type="checkbox"/>
BETTER	3.1.2 Provide real-time arrival information display at entrances (<i>multi-family, condominium</i>)	<input type="checkbox"/>
3.2 Transit fare incentives		
BASIC ★	3.2.1 Offer PRESTO cards preloaded with one monthly transit pass on residence purchase/move-in, to encourage residents to use transit	<input type="checkbox"/>
BETTER	3.2.2 Offer at least one year of free monthly transit passes on residence purchase/move-in	<input type="checkbox"/>
3.3 Enhanced public transit service		
BETTER ★	3.3.1 Contract with OC Transpo to provide early transit services until regular services are warranted by occupancy levels (<i>subdivision</i>)	<input type="checkbox"/>
3.4 Private transit service		
BETTER	3.4.1 Provide shuttle service for seniors homes or lifestyle communities (e.g. scheduled mall or supermarket runs)	<input type="checkbox"/>
4. CARSHARING & BIKESHARING		
4.1 Bikeshare stations & memberships		
BETTER	4.1.1 Contract with provider to install on-site bikeshare station (<i>multi-family</i>)	<input type="checkbox"/>
BETTER	4.1.2 Provide residents with bikeshare memberships, either free or subsidized (<i>multi-family</i>)	<input type="checkbox"/>
4.2 Carshare vehicles & memberships		
BETTER	4.2.1 Contract with provider to install on-site carshare vehicles and promote their use by residents	<input type="checkbox"/>
BETTER	4.2.2 Provide residents with carshare memberships, either free or subsidized	<input type="checkbox"/>
5. PARKING		
5.1 Priced parking		
BASIC ★	5.1.1 Unbundle parking cost from purchase price (<i>condominium</i>)	<input type="checkbox"/>
BASIC ★	5.1.2 Unbundle parking cost from monthly rent (<i>multi-family</i>)	<input type="checkbox"/>

TDM measures: <i>Residential developments</i>		Check if proposed & add descriptions
6. TDM MARKETING & COMMUNICATIONS		
6.1 Multimodal travel information		
BASIC ★	6.1.1 Provide a multimodal travel option information package to new residents	<input checked="" type="checkbox"/>
6.2 Personalized trip planning		
BETTER ★	6.2.1 Offer personalized trip planning to new residents	<input type="checkbox"/>

Patricia Warren
Fotenn
September 19, 2025

Appendix D: Swept Path Analysis

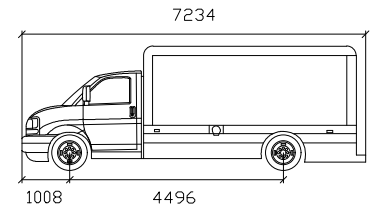

Chevrolet Express 4500 (2016)

	mm
Width	: 2410
Track	: 1957
Lock to Lock Time	: 6.0
Steering Angle	: 31.7

BLOCK 246
(STREET WIDENING)

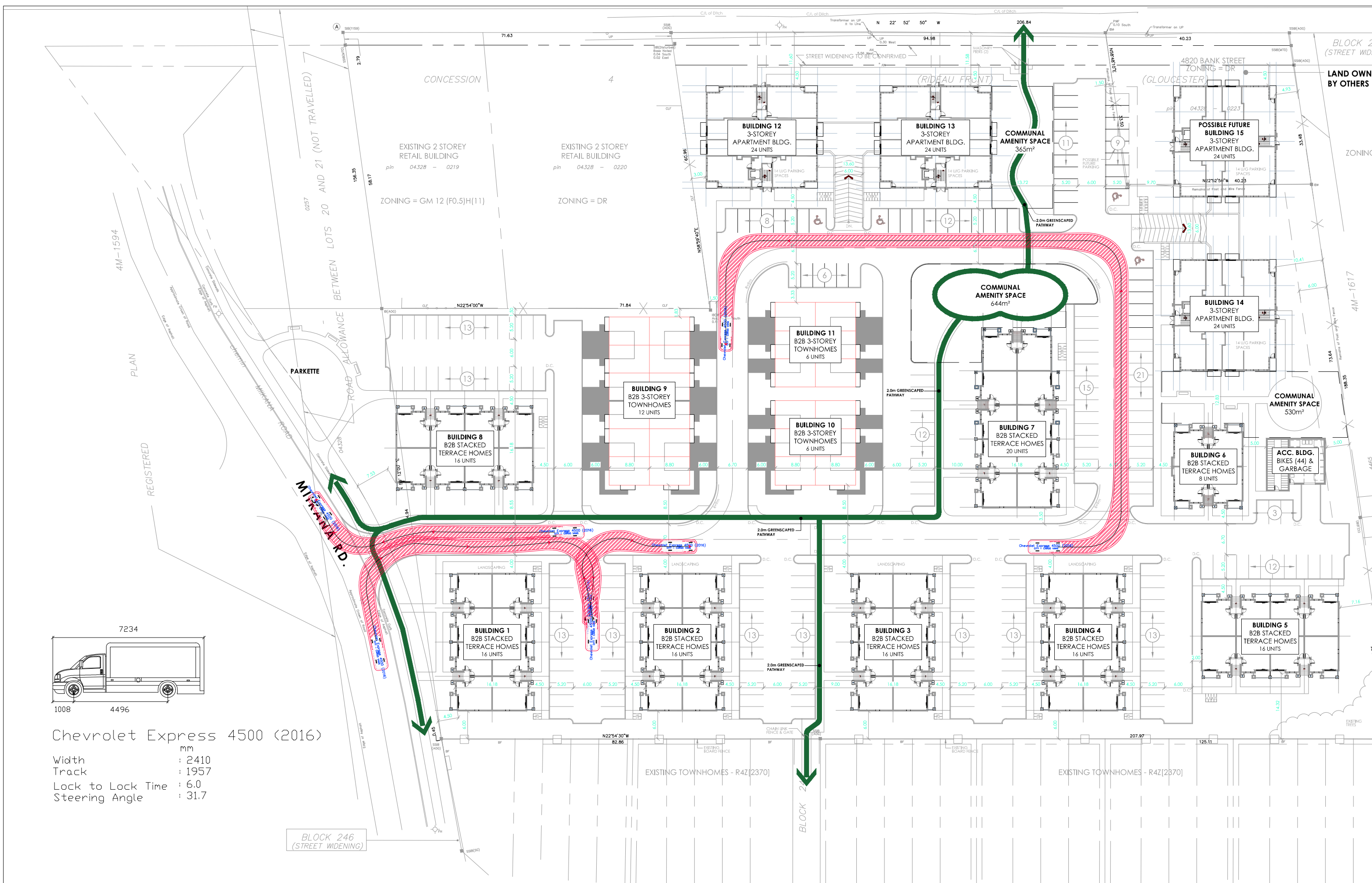

BLOCK 2
(STREET WIDENING)

LAND OWNED BY OTHERS

ZONING

COMMUNAL AMENITY SPACE 530m²

ACC. BLDG. BIKES (44) & GARBAGE

BUILDING 5
B2B STACKED TERRACE HOMES
16 UNITS

BUILDING 4
B2B STACKED TERRACE HOMES
16 UNITS

BUILDING 3
B2B STACKED TERRACE HOMES
16 UNITS

BUILDING 2
B2B STACKED TERRACE HOMES
16 UNITS

BUILDING 1
B2B STACKED TERRACE HOMES
16 UNITS

BUILDING 6
B2B STACKED TERRACE HOMES
8 UNITS

BUILDING 7
B2B STACKED TERRACE HOMES
20 UNITS

BUILDING 10
B2B 3-STORY TOWNHOMES
6 UNITS

BUILDING 11
B2B 3-STORY TOWNHOMES
6 UNITS

BUILDING 12
3-STORY APARTMENT BLDG.
24 UNITS

BUILDING 13
3-STORY APARTMENT BLDG.
24 UNITS

BUILDING 14
3-STORY APARTMENT BLDG.
24 UNITS

POSSIBLE FUTURE BUILDING 15
3-STORY APARTMENT BLDG.
24 UNITS

4820 BANK STREET
ZONING = DR

(GLOUCESTER)

(RIDEAU FRONT)

CONCESSION

EXISTING 2 STOREY RETAIL BUILDING

EXISTING 2 STOREY RETAIL BUILDING

ZONING = GM 12 (F0.5)H(11)

ZONING = DR

STREET WIDENING TO BE CONFIRMED

TRANSFORMER ON UP

TRANSFORMER ON UP

TRANSFORMER ON UP

TRANSFORMER ON UP

TRANSFORMER ON UP

TRANSFORMER ON UP

TRANSFORMER ON UP

TRANSFORMER ON UP

TRANSFORMER ON UP

TRANSFORMER ON UP

TRANSFORMER ON UP

TRANSFORMER ON UP

TRANSFORMER ON UP

TRANSFORMER ON UP

TRANSFORMER ON UP

TRANSFORMER ON UP

TRANSFORMER ON UP

TRANSFORMER ON UP

TRANSFORMER ON UP

TRANSFORMER ON UP

TRANSFORMER ON UP

TRANSFORMER ON UP

TRANSFORMER ON UP

TRANSFORMER ON UP

TRANSFORMER ON UP

TRANSFORMER ON UP

TRANSFORMER ON UP

TRANSFORMER ON UP

TRANSFORMER ON UP

TRANSFORMER ON UP

TRANSFORMER ON UP

TRANSFORMER ON UP

TRANSFORMER ON UP

TRANSFORMER ON UP

TRANSFORMER ON UP

TRANSFORMER ON UP

TRANSFORMER ON UP

TRANSFORMER ON UP

TRANSFORMER ON UP

TRANSFORMER ON UP

TRANSFORMER ON UP

TRANSFORMER ON UP

TRANSFORMER ON UP

TRANSFORMER ON UP

TRANSFORMER ON UP

TRANSFORMER ON UP

TRANSFORMER ON UP

TRANSFORMER ON UP

TRANSFORMER ON UP

TRANSFORMER ON UP

TRANSFORMER ON UP

TRANSFORMER ON UP

TRANSFORMER ON UP

TRANSFORMER ON UP

TRANSFORMER ON UP

TRANSFORMER ON UP

TRANSFORMER ON UP

TRANSFORMER ON UP

TRANSFORMER ON UP

TRANSFORMER ON UP

TRANSFORMER ON UP

TRANSFORMER ON UP

TRANSFORMER ON UP

TRANSFORMER ON UP

TRANSFORMER ON UP

TRANSFORMER ON UP

TRANSFORMER ON UP

TRANSFORMER ON UP

TRANSFORMER ON UP

TRANSFORMER ON UP

TRANSFORMER ON UP

TRANSFORMER ON UP

TRANSFORMER ON UP

TRANSFORMER ON UP

TRANSFORMER ON UP

TRANSFORMER ON UP

TRANSFORMER ON UP

TRANSFORMER ON UP

TRANSFORMER ON UP

TRANSFORMER ON UP

TRANSFORMER ON UP

TRANSFORMER ON UP

TRANSFORMER ON UP

TRANSFORMER ON UP

TRANSFORMER ON UP

TRANSFORMER ON UP

TRANSFORMER ON UP

TRANSFORMER ON UP

TRANSFORMER ON UP

TRANSFORMER ON UP

TRANSFORMER ON UP

TRANSFORMER ON UP

TRANSFORMER ON UP

TRANSFORMER ON UP

TRANSFORMER ON UP

TRANSFORMER ON UP

TRANSFORMER ON UP

TRANSFORMER ON UP

TRANSFORMER ON UP

TRANSFORMER ON UP

TRANSFORMER ON UP

TRANSFORMER ON UP

TRANSFORMER ON UP

TRANSFORMER ON UP

TRANSFORMER ON UP

TRANSFORMER ON UP

TRANSFORMER ON UP

TRANSFORMER ON UP

TRANSFORMER ON UP

TRANSFORMER ON UP

TRANSFORMER ON UP

TRANSFORMER ON UP

TRANSFORMER ON UP

TRANSFORMER ON UP

TRANSFORMER ON UP

TRANSFORMER ON UP

TRANSFORMER ON UP

TRANSFORMER ON UP

TRANSFORMER ON UP

TRANSFORMER ON UP

TRANSFORMER ON UP

TRANSFORMER ON UP

TRANSFORMER ON UP

TRANSFORMER ON UP

TRANSFORMER ON UP

TRANSFORMER ON UP

TRANSFORMER ON UP

TRANSFORMER ON UP

TRANSFORMER ON UP

TRANSFORMER ON UP

TRANSFORMER ON UP

TRANSFORMER ON UP

TRANSFORMER ON UP

TRANSFORMER ON UP

TRANSFORMER ON UP

TRANSFORMER ON UP

TRANSFORMER ON UP

TRANSFORMER ON UP

TRANSFORMER ON UP

TRANSFORMER ON UP

TRANSFORMER ON UP

TRANSFORMER ON UP

TRANSFORMER ON UP

TRANSFORMER ON UP

TRANSFORMER ON UP

TRANSFORMER ON UP

TRANSFORMER ON UP

TRANSFORMER ON UP

TRANSFORMER ON UP

TRANSFORMER ON UP

TRANSFORMER ON UP

TRANSFORMER ON UP

TRANSFORMER ON UP

TRANSFORMER ON UP

TRANSFORMER ON UP

TRANSFORMER ON UP

TRANSFORMER ON UP

TRANSFORMER ON UP

TRANSFORMER ON UP

TRANSFORMER ON UP

TRANSFORMER ON UP

TRANSFORMER ON UP

TRANSFORMER ON UP

TRANSFORMER ON UP

TRANSFORMER ON UP

TRANSFORMER ON UP

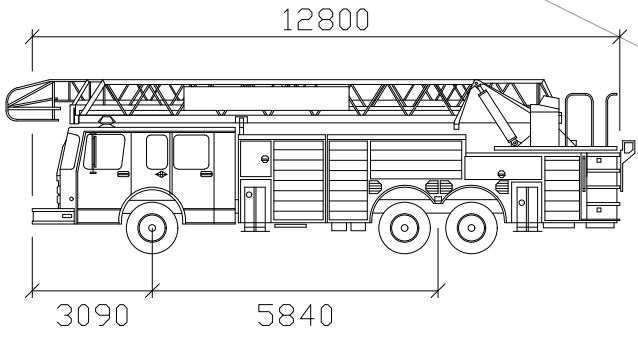
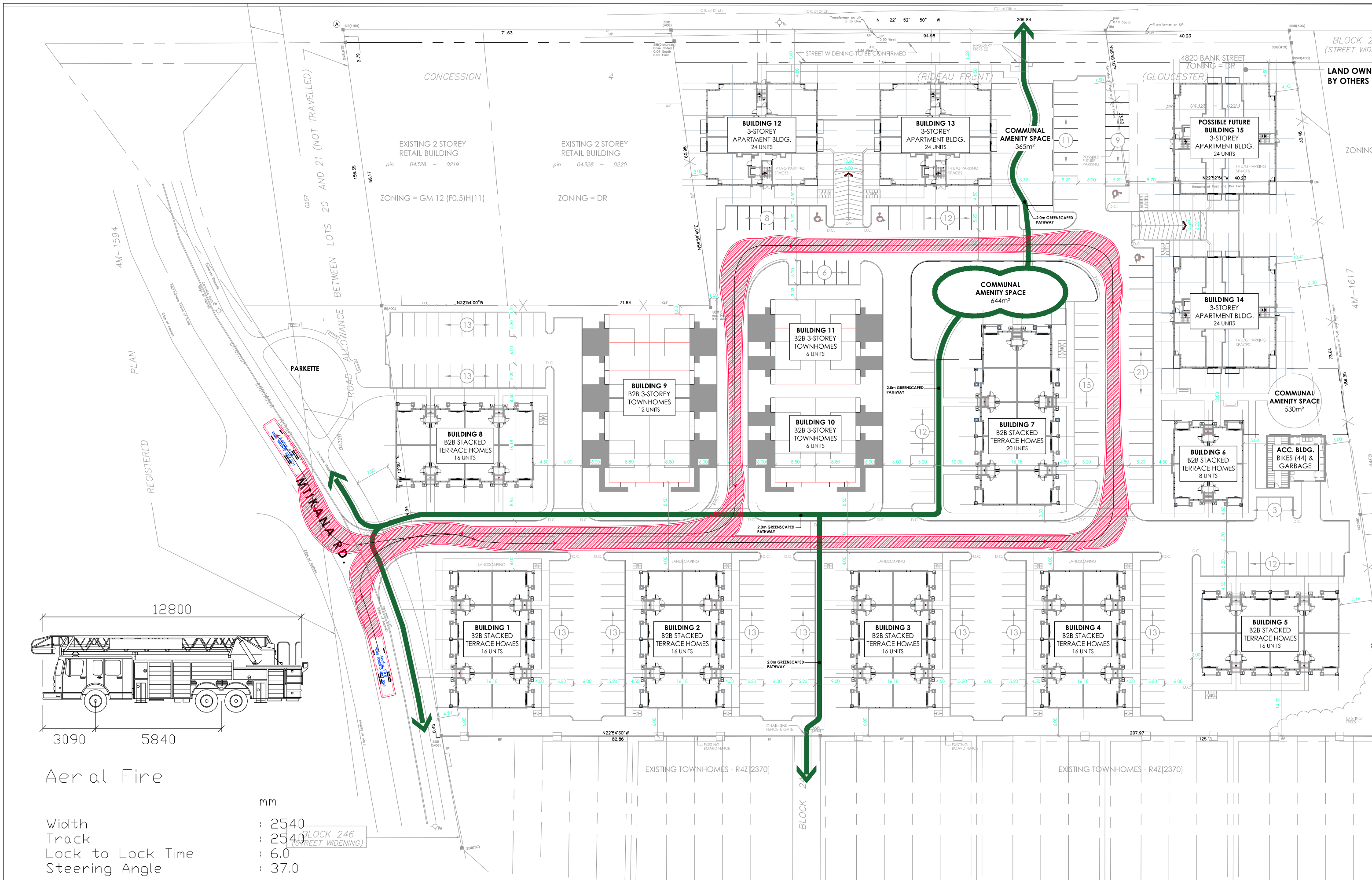

Aerial Fire

- mm
- Width : 2540
- Track : 2540
- Lock to Lock Time : 6.0
- Steering Angle : 37.0

BLOCK 246
(STREET WIDENING)

BLOCK 2
(STREET WIDENING)
LAND OWNED BY OTHERS
ZONING

4M-1594
4M-1617
4465

BLOCK 246

EXISTING TOWNHOMES - R4Z[2370]

EXISTING TOWNHOMES - R4Z[2370]

ZONING = GM 12 (F0.5)H(11)

ZONING = DR

4820 BANK STREET
ZONING = DR

ACC. BLDG.
BIKES (44) &
GARBAGE

PARKETTE

MITKANA RD.

BETWEEN LOTS 20 AND 21 (NOT TRAVELLED)

EXISTING 2 STOREY
RETAIL BUILDING
pin 04328 - 0219

EXISTING 2 STOREY
RETAIL BUILDING
pin 04328 - 0220

BUILDING 12
3-STOREY
APARTMENT BLDG.
24 UNITS

BUILDING 13
3-STOREY
APARTMENT BLDG.
24 UNITS

COMMUNAL
AMENITY SPACE
365m²

POSSIBLE FUTURE
BUILDING 15
3-STOREY
APARTMENT BLDG.
24 UNITS

BUILDING 8
B2B STACKED
TERRACE HOMES
16 UNITS

BUILDING 9
B2B 3-STOREY
TOWNHOMES
12 UNITS

BUILDING 10
B2B 3-STOREY
TOWNHOMES
6 UNITS

BUILDING 7
B2B STACKED
TERRACE HOMES
20 UNITS

BUILDING 14
3-STOREY
APARTMENT BLDG.
24 UNITS

COMMUNAL
AMENITY SPACE
530m²

BUILDING 6
B2B STACKED
TERRACE HOMES
8 UNITS

BUILDING 1
B2B STACKED
TERRACE HOMES
16 UNITS

BUILDING 2
B2B STACKED
TERRACE HOMES
16 UNITS

BUILDING 3
B2B STACKED
TERRACE HOMES
16 UNITS

BUILDING 4
B2B STACKED
TERRACE HOMES
16 UNITS

BUILDING 5
B2B STACKED
TERRACE HOMES
16 UNITS

