

1657-1673 Carling Avenue and 386 Tillbury Avenue Transportation Impact Assessment

Step 1 Screening Report

Step 2 Scoping Report

Step 3 Strategy Report

Prepared for:

1657-1672 Carling Avenue Limited Partnership
2020-464 Bank Street
Ottawa, ON K2P 1Z3

Prepared by:



6 Plaza Court
Ottawa, ON K2H 7W1

June 2024

PN: 2023-088

Table of Contents

1	Screening.....	3
2	Existing and Planned Conditions.....	3
2.1	Proposed Development.....	3
2.2	Existing Conditions.....	5
2.2.1	Area Road Network.....	5
2.2.2	Existing Intersections.....	5
2.2.3	Existing Driveways.....	6
2.2.4	Cycling and Pedestrian Facilities.....	6
2.2.5	Existing Transit.....	9
2.2.6	Existing Area Traffic Management Measures.....	10
2.2.7	Existing Peak Hour Travel Demand.....	10
2.2.8	Collision Analysis.....	12
2.3	Planned Conditions.....	15
2.3.1	Changes to the Area Transportation Network.....	15
2.3.2	Other Study Area Developments.....	15
3	Study Area and Time Periods.....	16
3.1	Study Area.....	16
3.2	Time Periods.....	16
3.3	Horizon Years.....	16
4	Development-Generated Travel Demand.....	16
4.1	Mode Shares.....	16
4.2	Trip Generation.....	16
4.3	Trip Distribution.....	18
4.4	Trip Assignment.....	18
5	Exemption Review.....	19
6	Development Design.....	21
6.1	Design for Sustainable Modes.....	21
6.2	Circulation and Access.....	21
7	Parking.....	21
7.1	Parking Supply.....	21
8	Boundary Street Design.....	21
9	Transportation Demand Management.....	22
9.1	Context for TDM.....	22
9.2	Need and Opportunity.....	22
9.3	TDM Program.....	22
10	Summary of Improvements Indicated and Modifications Options.....	23
11	Conclusion.....	25

List of Figures

Figure 1:	Area Context Plan.....	3
Figure 2:	Concept Plan.....	4

Figure 3: Existing Driveways6
 Figure 4: Study Area Pedestrian Facilities7
 Figure 5: Study Area Cycling Facilities7
 Figure 6: Existing Pedestrian Volumes8
 Figure 7: Existing Cyclist Volumes8
 Figure 8: Existing Study Area Transit Service.....9
 Figure 9: Existing Study Area Transit Stops 10
 Figure 10: Existing Traffic Counts 11
 Figure 11: Study Area Collision Records..... 13
 Figure 12: New Site Generation Auto Volumes..... 19

Table of Tables

Table 1: Intersection Count Date..... 10
 Table 2: Existing Intersection Operations..... 11
 Table 3: Study Area Collision Summary, 2018-2022 12
 Table 4: Summary of Collision Locations, 2018-2022..... 13
 Table 5: Carling Avenue at Clyde Avenue/Cole Avenue Collision Summary 14
 Table 6: Carling Avenue at Churchill Avenue Collision Summary..... 14
 Table 7: TRANS Trip Generation Manual Recommended Mode Shares – Ottawa West 16
 Table 8: Trip Generation Person Trip Rates..... 16
 Table 9: Total Residential Person Trip Generation..... 17
 Table 10: Internal Capture Rates..... 17
 Table 11: Trip Generation by Mode 17
 Table 12: OD Survey Distribution – Ottawa West 18
 Table 13: Trip Assignment 18
 Table 14: Exemption Review 19
 Table 15: Boundary Street MMLOS Analysis 22

List of Appendices

- Appendix A – TIA Screening Form and Certification Form
- Appendix B – Turning Movement Count Data
- Appendix C – Synchro Intersection Worksheets – Existing Conditions
- Appendix D – Collision Data
- Appendix E – Carling Avenue Transit Priority Measures Plan
- Appendix F – TDM Checklist
- Appendix G – Turing Templates
- Appendix H – MMLOS Analysis

1 Screening

This study has been prepared according to the City of Ottawa’s 2017 Transportation Impact Assessment (TIA) Guidelines, incorporating the 2023 Revision to Transportation Impact Assessment Guidelines. Accordingly, a Step 1 Screening Form has been prepared and is included as Appendix A, along with the Certification Form for the TIA Study PM. As shown in the Screening Form, a TIA is required, and this study has been prepared to support a zoning bylaw amendment application.

2 Existing and Planned Conditions

2.1 Proposed Development

The development site is located at 1657-1673 Carling Avenue and 386 Tillbury Avenue is zoned as Arterial Mainstreet (AM10) for the Carling Avenue parcels and Residential Fourth Density (R4UC) for the Tillbury Avenue parcel. The proposed development concept consists of a mixed-use building including 370 residential units, 3,883 square feet retail space, 212 vehicle parking spaces, and 202 bicycle parking spaces. The accesses will be located approximately at the existing access on Carling Avenue and existing residential driveway on Tillbury Avenue. An internal drive aisle will connect through the site between the accesses. Construction will occur in a single phase estimated to proceed after 2025, upon completion of a future site plan application. Figure 1 illustrates the study area context. Figure 2 illustrates the proposed concept plan.

Figure 1: Area Context Plan

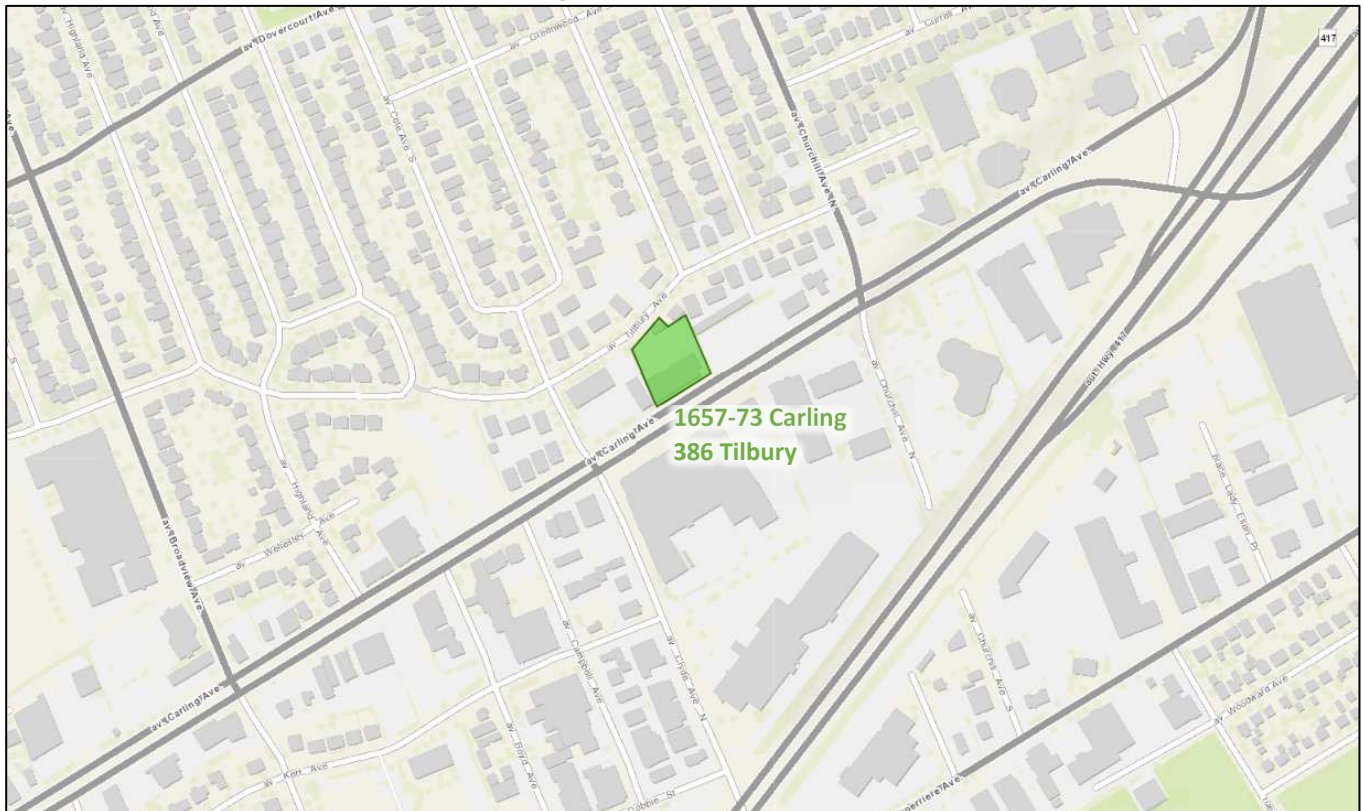

Source: <http://maps.ottawa.ca/geoOttawa/> Accessed: June 27, 2023

Figure 2: Concept Plan

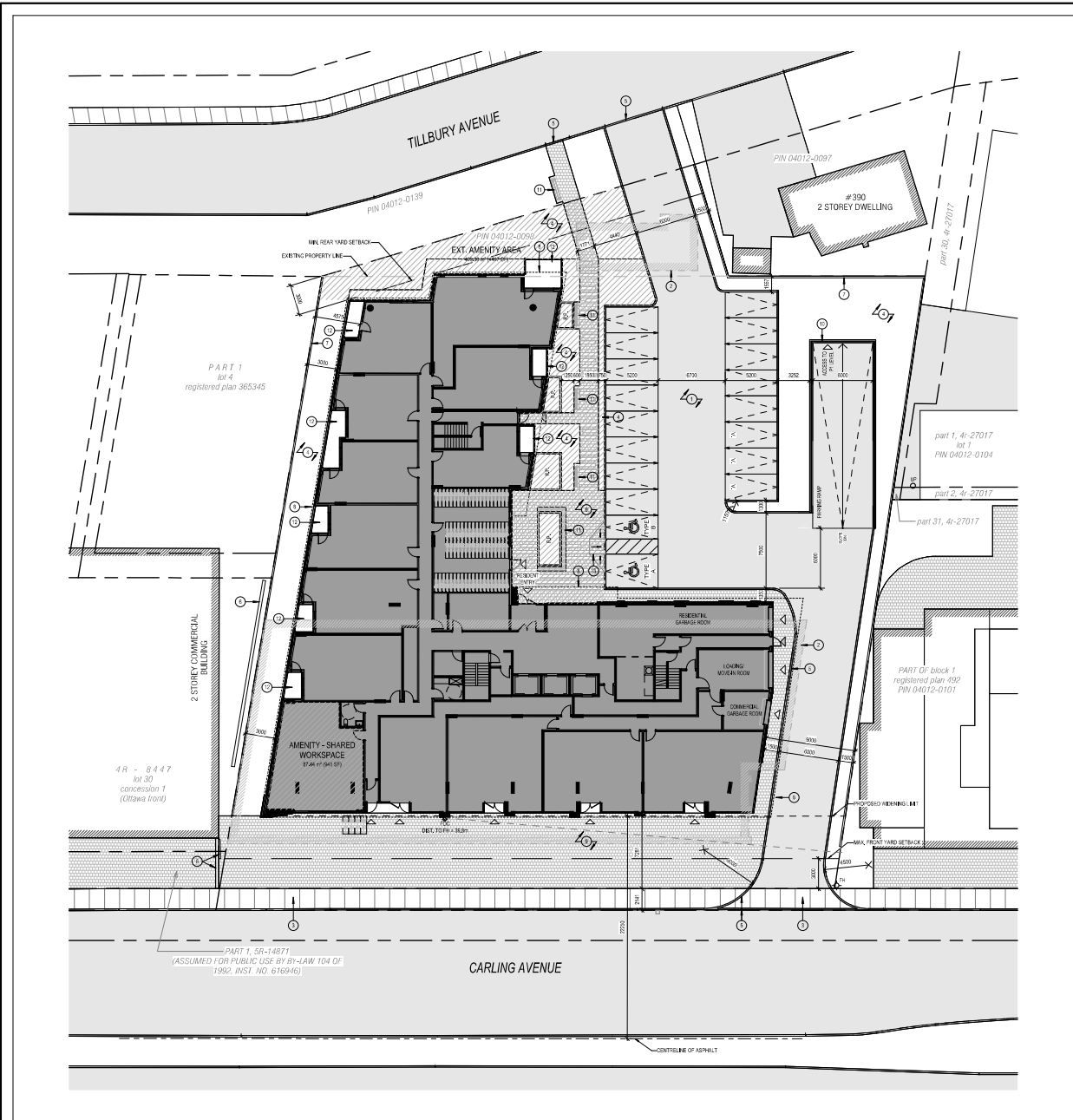

1 SITE PLAN
SP-01 SCALE: 1:200

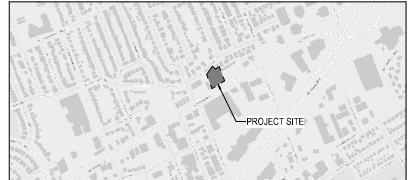

2 LOCATION PLAN
SP-01 SCALE: NTS

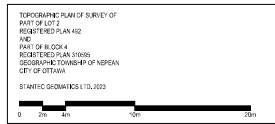
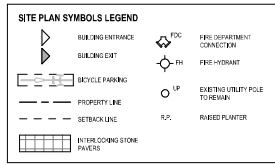

3 SURVEY INFO
SCALE: 1:200

- SITE PLAN NOTES**
- 1 ASPHALT
 - 2 EXISTING STRUCTURE TO BE DEMOLISHED
 - 3 CONCRETE SIDEWALK
 - 4 SOFT LANDSCAPING
 - 5 DRINKING CURBS
 - 6 EXISTING RETAINING WALL
 - 7 2M HIGH WOOD FENCE
 - 8 CHERRY TREES ABOVE
 - 9 HARD LANDSCAPING
 - 10 RAMPING AROUND PARKING RAMP PERIMETER
 - 11 BENCH
 - 12 PRIVATE TERRACE
 - 13 CURB RAMP

OWNER
INSIDE EDGE PROPERTIES
464 BANK STREET, SUITE 200
OTTAWA, ON, K2P 1Z3

ARCHITECT
PROJECT1 STUDIO
260 ST. PATRICK ST., SUITE 300
OTTAWA, ON, K1N 5K5

PLANNER
FOTENI PLANNING + DESIGN
396 COOPER ST SUITE, SUITE 300
OTTAWA, ON, K2P 2H7

CIVIL ENGINEER
LRL ENGINEERING
5420 CANOTER RD.
OTTAWA, ON, K1J 9G2

LANDSCAPE ARCHITECT
XXX
XXX
XXX

SURVEYOR
STAMPEC GEOMATICS LTD.
1531 CLUDE AVENUE, SUITE 300
OTTAWA, ON, K2C 0A9

- GENERAL ARCHITECTURAL NOTES**
- This drawing is the property of the Architect and may not be reproduced or used without the written consent of the Architect.
 - Drawings are to be used for the construction of the building. The Contractor is responsible for checking and verifying all field and dimensions and all material quantities in the field and on-site. It is the contractor's responsibility to verify all dimensions and quantities in the field and on-site.
 - Operations and methods of construction are the responsibility of the contractor. The Architect is not responsible for the safety of the construction site or the safety of the construction workers.
 - The Architect is not responsible for the safety of the construction site or the safety of the construction workers.
 - The Architect is not responsible for the safety of the construction site or the safety of the construction workers.
 - The Architect is not responsible for the safety of the construction site or the safety of the construction workers.

3	ISSUED FOR REZONING	2024-05-29
2	ISSUED FOR COORDINATION	2024-02-07
1	ISSUED FOR COORDINATION	2023-10-20

ISSUE RECORD



1657 CARLING
1657 Carling Ave
Ottawa, ON K2A 0Y2

PROJ.	SCALE	DRAWN	REVIEWED
2213	NOTED	JH/BH	RMK

SITE PLAN
SP-01

2.2 Existing Conditions

2.2.1 Area Road Network

Carling Avenue: Carling Avenue is a City of Ottawa arterial road with a six-lane divided urban cross-section. Sidewalks are provided on both sides of the roadway. The posted speed limit is 60 km/h. The Ottawa Official Plan reserves a 44.5 metre right of way.

Churchill Avenue: Churchill Avenue is a City of Ottawa major collector road with a two-lane urban cross-section. Sidewalks and cycle tracks on both sides of the road north of Carling Avenue. The posted speed limit is 50 km/h and on-street parking is provided, predominantly in layby/parking bays. The existing right-of-way is 20 metres.

Clyde Avenue: Clyde Avenue is a City of Ottawa local road with a two-lane urban cross-section, with auxiliary left-turn lanes between Carling Avenue and Doheny Street, transitioning to two-lanes with parking on both sides to the south of Doheny Street. A sidewalk is located on the east side of the road, with varying hard surfaces permitting pedestrian movements on the west side. An unposted speed limit of 50 km/h is assumed for the roadway. The existing right-of-way is 20 metres.

Cole Avenue: Cole Avenue is a City of Ottawa local road with a two-lane urban cross-section and is located within a posted 30 km/h area speed limit. A sidewalk is located on both sides of the road between Carling Avenue and Tillbury Avenue, and a sidewalk is located on the east side of the road to the north of Tillbury Avenue. Parking is permitted on both sides of the roadway. The existing right-of-way is 20 metres.

Tillbury Avenue: Tillbury Avenue is a City of Ottawa local road with a two-lane urban cross-section and is located within a posted 30 km/h area speed limit. A sidewalk is located on the south side to the west of Cole Avenue, on the north side between Cole Avenue and Melbourne Avenue, and both sides of the road between Melbourne Avenue and Churchill Avenue. Parking is permitted on both sides of the roadway. The existing right-of-way is 20 metres.

2.2.2 Existing Intersections

The key intersections within 400 metre of the site have been summarized below:

Carling Avenue at Clyde Avenue/Cole Avenue The intersection of Carling Avenue at Clyde Avenue/Cole Avenue is a signalized intersection. The eastbound and westbound approaches consist of an auxiliary left-turn lane, two through lanes, and a shared through/right-turn lane. The northbound approach consists of an auxiliary left-turn lane, a through lane and a short auxiliary right-turn lane, and the southbound approach consists of an auxiliary left-turn lane and a shared through/right-turn lane. No turn restrictions were noted.

Carling Avenue at Churchill Avenue The intersection of Carling Avenue at Churchill Avenue is a signalized intersection. The eastbound and westbound approaches consist of an auxiliary left-turn lane, two through lanes, and a shared through/right-turn lane. The northbound and southbound approaches consist of an auxiliary left-turn lane and a shared through/right-turn lane. The northbound approach includes a cycletrack and the southbound approach has a bike lane. No turn restrictions were noted.

Tillbury Avenue at Churchill Avenue

The intersection of Churchill Avenue at Tillbury Avenue is a minor stop-controlled intersection, with all approaches operating as shared all movement lanes. A cycle track cross-ride is present on the Tillbury Avenue approach. No turn restrictions were noted.

Tillbury Avenue at Cole Avenue

The intersection of Cole Avenue at Tillbury Avenue is a minor stop-controlled intersection, with all approaches operating as shared all movement lanes. No turn restrictions were noted.

2.2.3 Existing Driveways

Within 200 metres of the proposed site access, numerous residential driveways are located to the north, and commercial entrances are located along Carling Avenue and Clyde Avenue.

Figure 3: Existing Driveways



Source: <http://maps.ottawa.ca/geoOttawa/> Accessed: June 27, 2023

2.2.4 Cycling and Pedestrian Facilities

Figure 4 illustrates the pedestrian facilities in the study area and Figure 5 illustrates the cycling facilities.

Within the study area, sidewalks are provided along both sides of Carling Avenue, Churchill Avenue north of Carling Avenue, and a section of Cole Avenue, with sidewalks on a single side on various local roads. Future projects will extend these sidewalks to connect through the residential community.

Cycletracks are provided along Churchill Avenue north of Carling Avenue with suggested bike routes through the communities to the north and south of Carling Avenue. Carling Avenue is designated a spine route. Future projects will add signage and pavement markings to the suggested bike routes.

Figure 4: Study Area Pedestrian Facilities

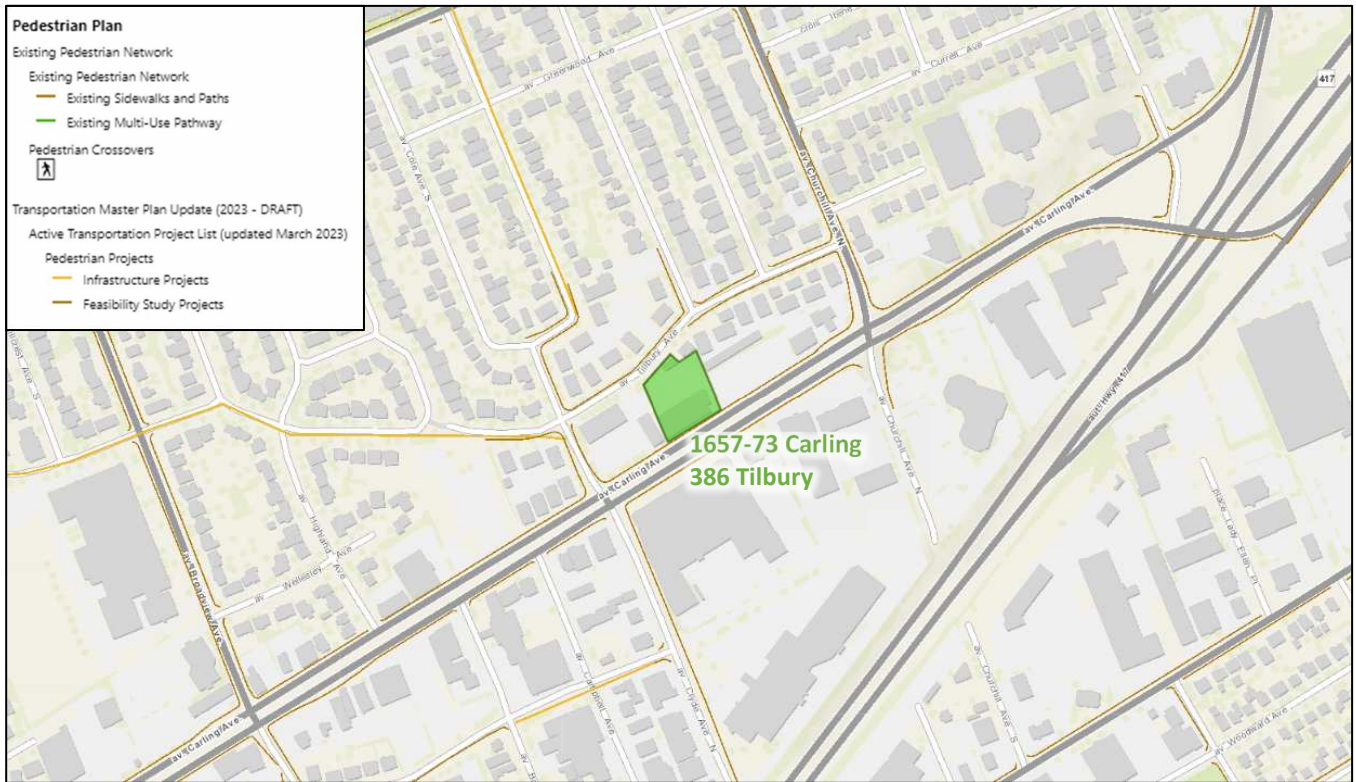

Source: <http://maps.ottawa.ca/geoOttawa/> Accessed: June 27, 2023

Figure 5: Study Area Cycling Facilities

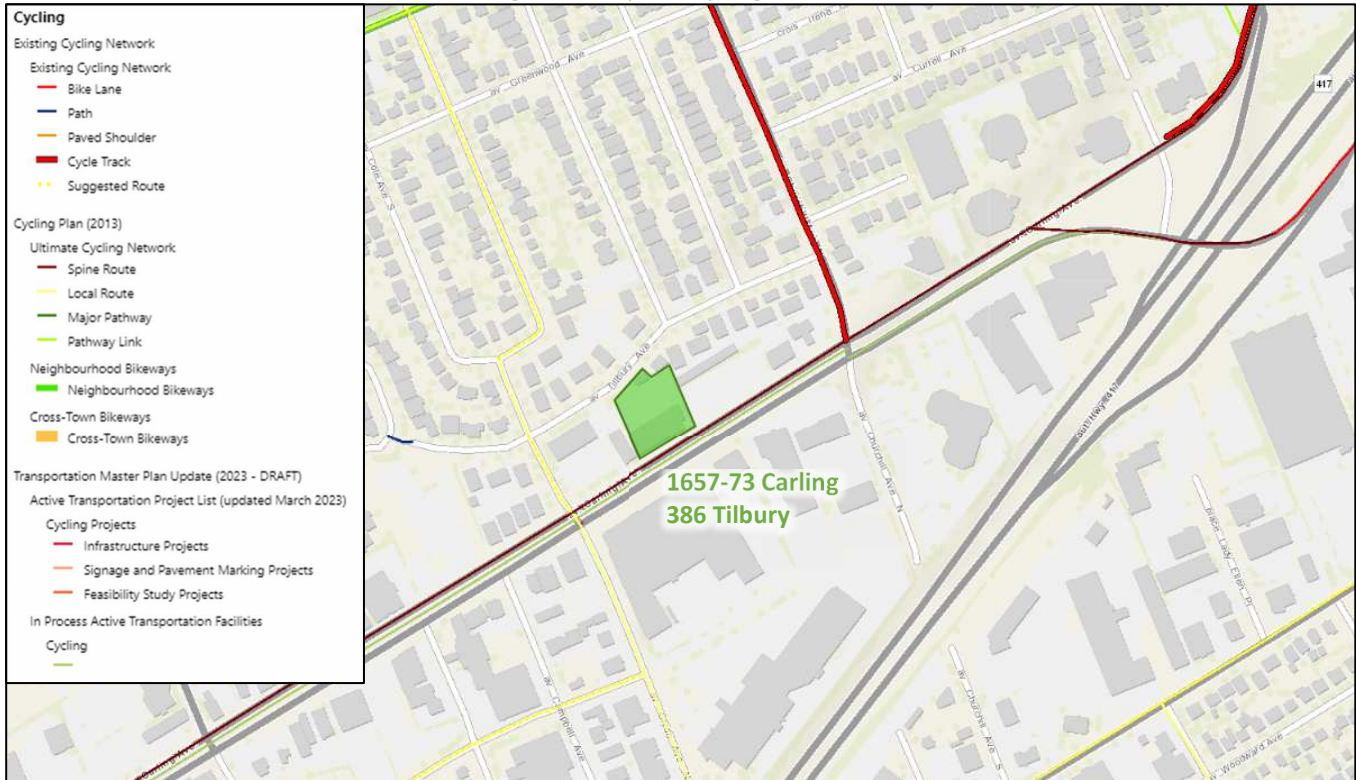

Source: <http://maps.ottawa.ca/geoOttawa/> Accessed: June 27, 2023

Pedestrian and cyclist volumes included in study area intersection counts, presented in Section 2.2.7, have been compiled and are illustrated in Figure 6 and Figure 7, respectively. The cyclist volumes at the intersections of Churchill Avenue at Tillbury Avenue and Cole Avenue at Tillbury Avenue were assumed from adjacent intersections.

Figure 6: Existing Pedestrian Volumes

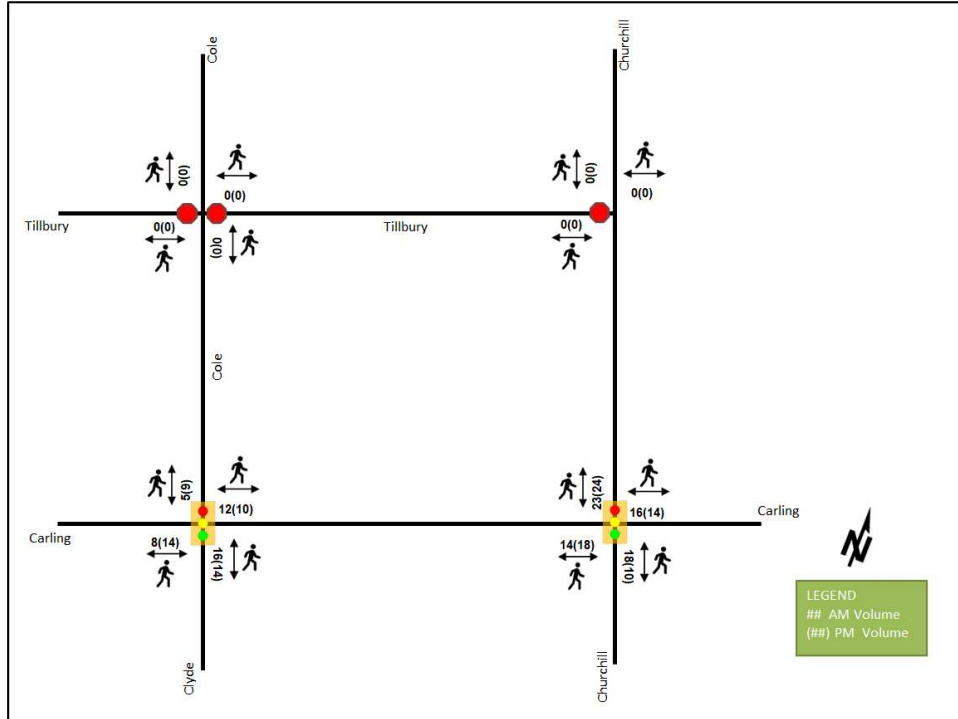
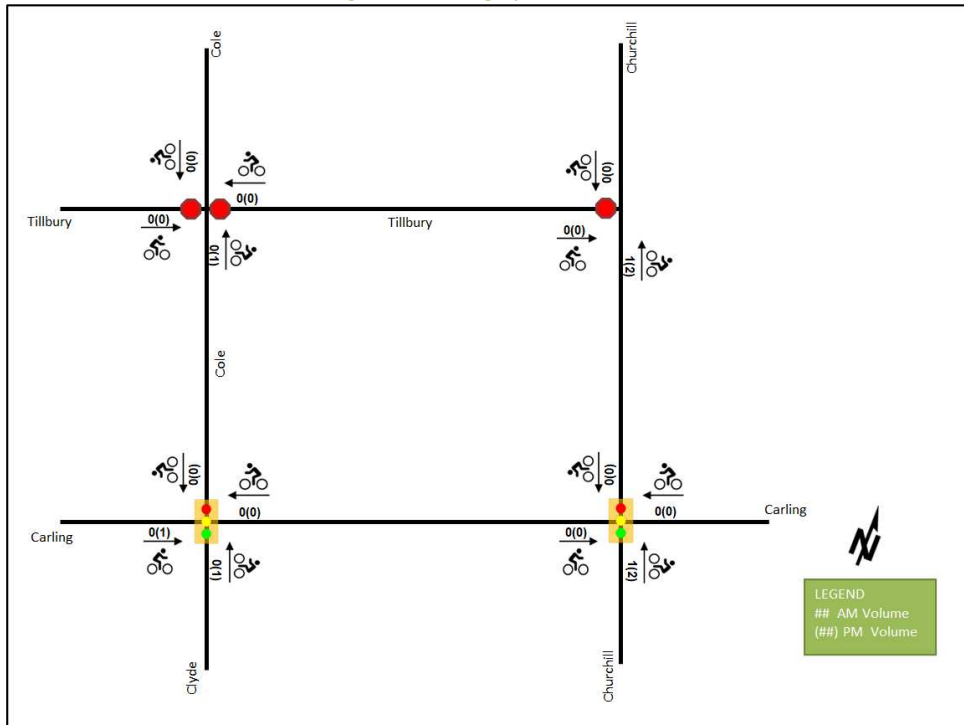

Figure 7: Existing Cyclist Volumes



2.2.5 Existing Transit

Figure 8 illustrates the transit system map in the study area and Figure 9 illustrates nearby transit stops. All transit information is from June 27, 2023 and is included for general information purposes and context to the surrounding area.

Within the study area, frequent routes #51, #53, #80 and #85, local routes #50 #55 and #81, and limited-service route #114 are noted to provide service. Along the site frontage, routes #50 and #85 operate and the frequency of these routes within proximity of the proposed site based on May 18, 2023 service levels are:

- Route # 50 – 30-minute service all day
- Route # 85 – 15-minute service all day, 20-30-minute service after 6:00 PM

Figure 8: Existing Study Area Transit Service



Source: <http://www.octranspo.com/> Accessed: June 27, 2023

Figure 9: Existing Study Area Transit Stops

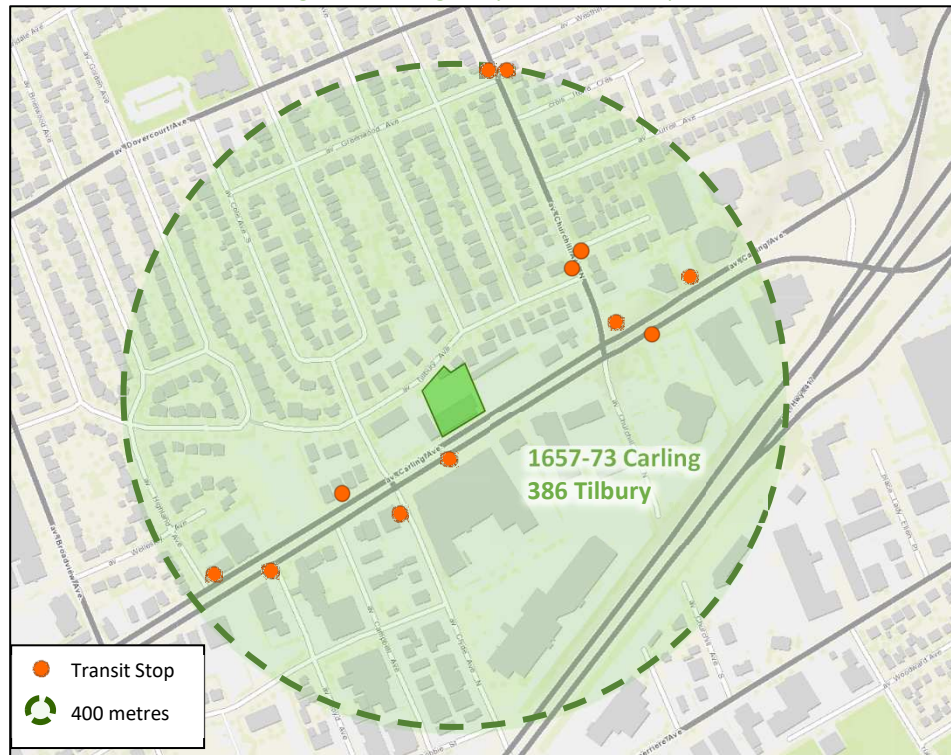

Source: <http://www.octranspo.com/> Accessed: June 27, 2023

2.2.6 Existing Area Traffic Management Measures

There are no existing area traffic management measures within the study area.

2.2.7 Existing Peak Hour Travel Demand

Existing turning movement counts were acquired from the City of Ottawa and The Traffic Specialist for the existing Study Area intersection. Table 1 summarizes the intersection count dates.

Table 1: Intersection Count Date

Intersection	Count Date	Source
Carling Ave at Clyde Ave/Cole Ave	Wednesday, February 23, 2022	City of Ottawa
Carling Ave at Churchill Ave	Tuesday, April 25, 2017	City of Ottawa
Churchill Avenue North at Tillbury Avenue	Monday, 30 September 2019	The Traffic Specialist
Cole Avenue at Tillbury Avenue	Monday, 30 September 2019	The Traffic Specialist

Figure 10 illustrates the existing traffic counts and Table 2 summarizes the existing intersection operations. The level of service for signalized intersections is based on volume to capacity ratio (v/c) calculations for individual lane movements and HCM 2000 v/c calculations for the overall intersection, and average delay for unsignalized intersections. Detailed turning movement count data is included in Appendix B and the Synchro worksheets are provided in Appendix C.

Figure 10: Existing Traffic Counts

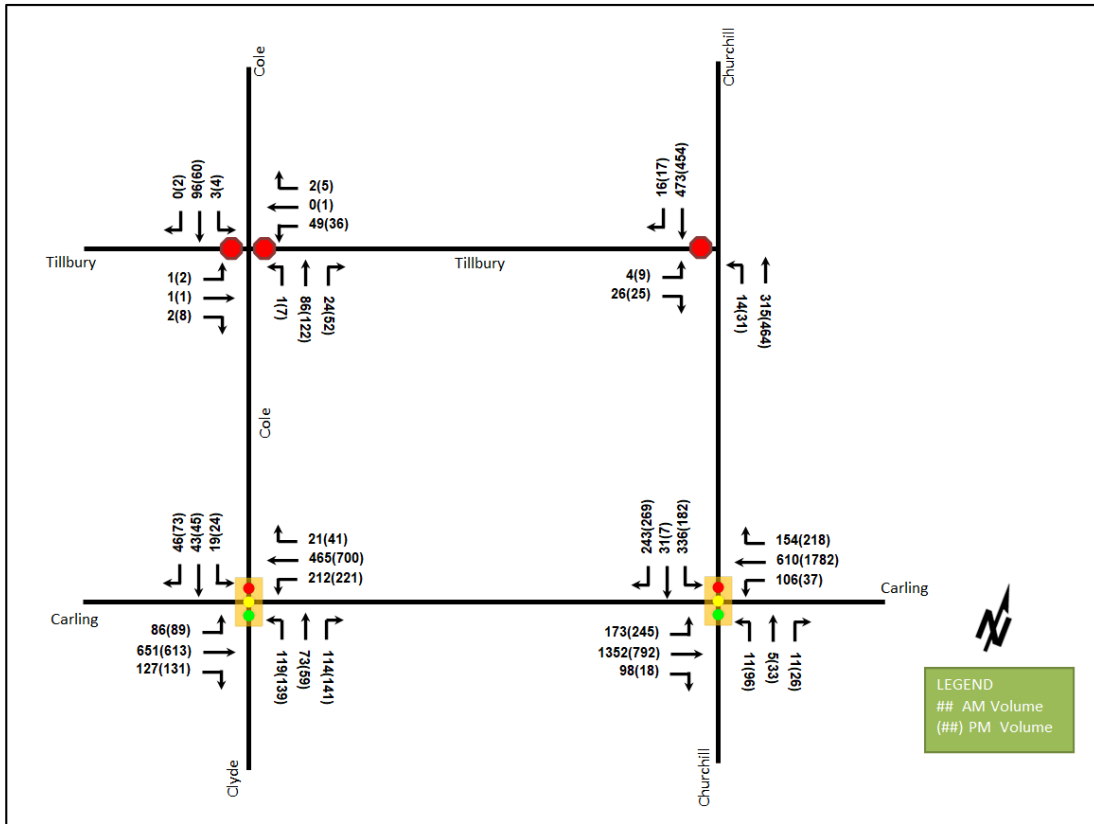

Table 2: Existing Intersection Operations

Intersection	Lane	AM Peak Hour				PM Peak Hour			
		LOS	V/C	Delay (s)	Q (95 th)	LOS	V/C	Delay (s)	Q (95 th)
Carling Ave at Clyde Ave/Cole Ave Ave Signalized	EBL	A	0.18	8.4	14.2	A	0.24	9.6	15.9
	EBT/R	A	0.35	16.3	57.3	A	0.32	16.8	58.3
	WBL	A	0.56	26.8	58.7	A	0.55	13.2	37.4
	WBT/R	A	0.20	10.9	25.3	A	0.29	14.7	53.2
	NBL	C	0.73	69.9	49.0	D	0.86	94.2	#70.6
	NBT	A	0.30	45.9	30.2	A	0.22	49.7	28.7
	NBR	A	0.43	17.4	22.6	A	0.45	16.2	26.7
	SBL	A	0.11	42.0	11.1	A	0.13	47.8	14.7
	SBT/R	A	0.35	29.6	27.0	A	0.42	33.2	37.3
Overall	A	0.59	21.0	-	B	0.61	22.2	-	
Carling Ave at Churchill Ave Signalized	EBL	D	0.83	85.7	#79.3	D	0.81	66.3	#122.4
	EBT/R	D	0.84	31.8	#163.8	A	0.36	18.6	65.6
	WBL	B	0.62	64.3	44.1	A	0.35	60.8	20.4
	WBT/R	A	0.50	27.9	65.6	F	1.24	145.8	#274.1
	NBL	A	0.07	33.5	7.0	E	1.00	134.0	#54.2
	NBT/R	A	0.06	19.2	6.7	A	0.18	22.6	17.4
	SBL	F	1.93	464.8	#193.6	C	0.78	64.1	67.2
	SBT/R	A	0.52	9.6	30.2	A	0.57	9.0	23.9
Overall	F	1.20	79.4	-	F	1.03	95.4	-	

Intersection	Lane	AM Peak Hour				PM Peak Hour			
		LOS	V/C	Delay (s)	Q (95 th)	LOS	V/C	Delay (s)	Q (95 th)
Churchill Avenue North at Tillbury Avenue <i>Unsignalized</i>	EB	A	0.01	9.5	0.0	A	0.01	9.2	0.0
	WB	B	0.08	10.3	2.3	B	0.07	10.5	1.5
	NB	A	0.00	7.4	0.0	A	0.01	7.4	0.0
	SB	A	0.00	7.5	0.0	A	0.00	7.6	0.0
	Overall	A	-	2.2	-	A	-	2.1	-
Cole Avenue at Tillbury Avenue <i>Unsignalized</i>	EBL/R	B	0.07	12.9	1.5	B	0.09	14.9	2.3
	NBL/T	A	0.02	8.6	0.0	A	0.03	8.6	0.8
	SBT/R	-	-	-	-	-	-	-	-
	Overall	A	-	0.6	-	A	-	0.8	-

Notes: Saturation flow rate of 1800 veh/h/lane
Queue is measured in metres
Peak Hour Factor = 0.90

Delay = average vehicle delay in seconds
m = metered queue.
= volume for the 95th %ile cycle exceeds capacity

At the intersection of Carling Avenue at Clyde Avenue/Cole Avenue during the PM peak hour, the northbound left-turn movement may be subject to high delays and extended queues.

At the intersection of Carling Avenue at Churchill Avenue, during the AM peak hour, the eastbound left-turn and eastbound shared through/right-turn movements may exhibit extended queues. High delays may be subject on the eastbound left-turn movement. The southbound left-turn movement is over theoretical capacity and may be subject to high delays and extended queues. During the PM peak hour, the eastbound left-turn and northbound left-turn movements may exhibit extended queues. High delays may be subject on the northbound left-turn movement. The westbound shared through/right-turn movement is over theoretical capacity and may be subject to high delays and extended queues. The overall intersection is forecasted to be over theoretical capacity during both peak hours. It is noted that the City will be upgrading the intersection within 2-3 years and it is recommended that it be reviewed at this time for potential capacity improvements along with the protected pedestrian and cycling improvements.

2.2.8 Collision Analysis

Collision data have been acquired from the City of Ottawa open data website (data.ottawa.ca) for five years prior to the commencement of this TIA for the surrounding study area road network. Table 3 summarizes the collision types and conditions in the study area, Figure 11 illustrates the intersections and segments analyzed, and Table 4 summarizes the total collisions for each of these locations. Collision data are included in Appendix D.

Table 3: Study Area Collision Summary, 2018-2022

Total Collisions		Number	%
		92	100%
Classification	Fatality	0	0%
	Non-Fatal Injury	29	32%
	Property Damage Only	63	68%
Initial Impact Type	Angle	5	5%
	Rear end	29	32%
	Sideswipe	25	27%
	Turning Movement	27	29%
	SMV Other	5	5%
	Other	1	1%
Road Surface Condition	Dry	63	68%
	Wet	14	15%
	Loose Snow	5	5%
	Slush	7	8%

		Number	%
Total Collisions		92	100%
	Packed Snow	2	2%
	Ice	1	1%
Pedestrian Involved		3	3%
Cyclists Involved		5	5%

Figure 11: Study Area Collision Records

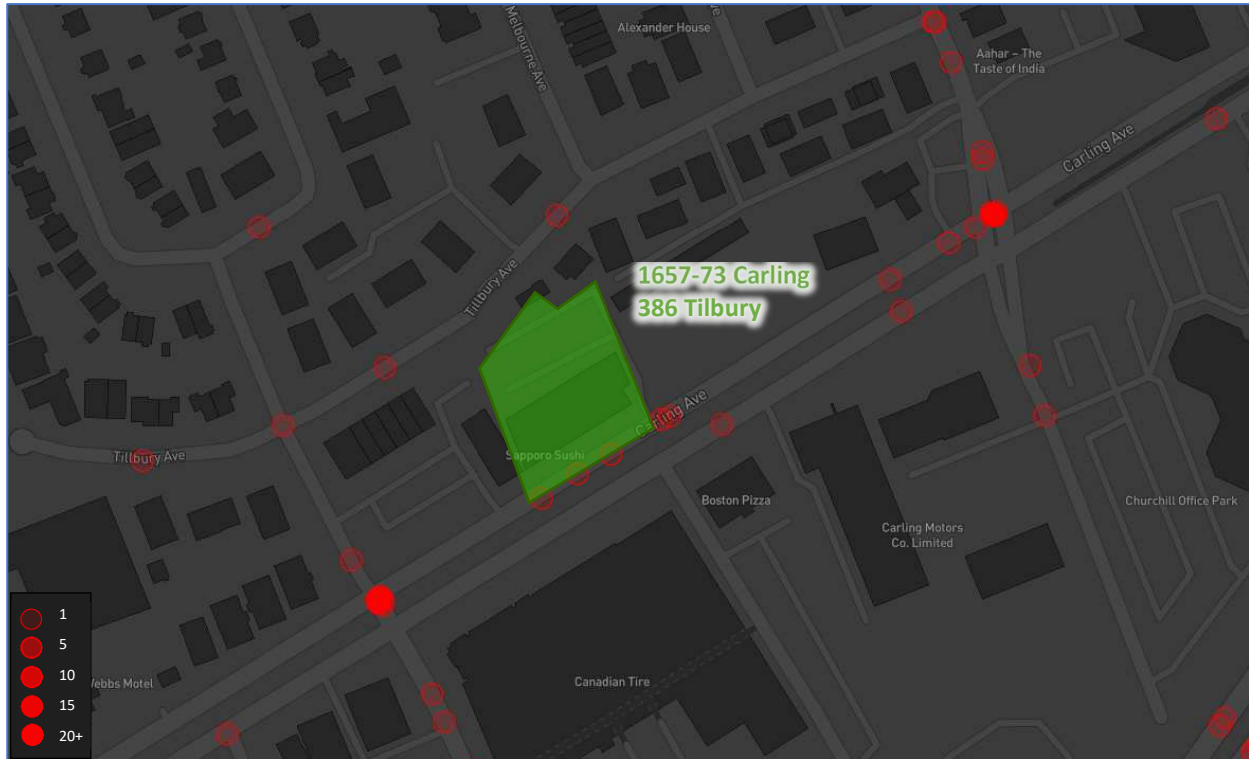

Table 4: Summary of Collision Locations, 2018-2022

Intersections / Segments	Number	%
Carling Ave at Clyde Ave/Cole Ave	48	52%
Carling Ave at Churchill Ave	30	33%
Carling Ave WB btwn Clyde Ave/Cole Ave and Churchill Ave	7	8%
Churchill Ave N Btwn Tillbury Ave & Carling Ave	2	2%
Churchill Ave at Tillbury Ave	2	2%
Cole Ave at Tillbury Ave	1	1%
Carling Ave EB btwn Clyde Ave/Cole Ave and Churchill Ave	1	1%
Cole Ave btwn Carling Ave and Tillbury Ave	1	1%

Within the study area, the intersection of Carling Avenue at Clyde Avenue/Cole Avenue and Carling Avenue at Churchill Avenue are noted to have experienced higher collisions than other intersections. Table 5 and Table 6 summarize the collision types and conditions for each of the intersections.

It is noted that five collisions occurred across the site frontage, which is on the segment of Carling Avenue Westbound between Clyde Avenue/Cole Avenue and Churchill Avenue. The collisions are likely due to loading or temporary stopping along the frontage and not due to the existing access locations. No further review of this segment is required as part of this study.

Table 5: Carling Avenue at Clyde Avenue/Cole Avenue Collision Summary

Total Collisions		Number	%
Total Collisions		48	100%
Classification	Fatality	0	0%
	Non-Fatal Injury	16	33%
	Property Damage Only	32	67%
Initial Impact Type	Angle	3	6%
	Rear end	9	19%
	Sideswipe	11	23%
	Turning Movement	22	46%
	SMV Other	2	4%
	Other	1	2%
Road Surface Condition	Dry	28	58%
	Wet	12	25%
	Loose Snow	2	4%
	Slush	4	8%
	Packed Snow	1	2%
	Ice	1	2%
Pedestrian Involved		2	4%
Cyclists Involved		2	4%

The Carling Avenue at Clyde Avenue/Cole Avenue intersection had a total of 48 collisions during the 2018-2022 time period, with 32 involving property damage only and the remaining 16 having non-fatal injuries. Turning movement comprised the majority of collision types at this intersection with 22 collisions, followed by eleven sideswipe, nine rear end, three angle collisions, two SMV other collisions, with the remaining one other collision. The detailed collision records outline that turning movement collisions are predominantly due to the eastbound and westbound left-turn movements interacting with the opposing westbound and eastbound through movements. It is noted that 18 collisions were noted in 2018 which may be related to the resurfacing/roadworks undertaken in 2018 into 2019. Weather conditions do not affect collisions at this location. Possible fully protected left-turn movements may reduce the turning movement collisions. No further examination is required as part of this study.

Table 6: Carling Avenue at Churchill Avenue Collision Summary

Total Collisions		Number	%
Total Collisions		30	100%
Classification	Fatality	0	0%
	Non-Fatal Injury	8	27%
	Property Damage Only	22	73%
Initial Impact Type	Angle	1	3%
	Rear end	16	53%
	Sideswipe	11	37%
	SMV Other	2	7%
Road Surface Condition	Dry	24	80%
	Wet	2	7%
	Loose Snow	1	3%
	Slush	3	10%
Pedestrian Involved		0	0%
Cyclists Involved		0	0%

The Carling Avenue at Churchill Avenue intersection had a total of 30 collisions during the 2018-2022 time period, with 22 involving property damage only and the remaining eight having non-fatal injuries. The collision types are most represented by rear end with 16 collisions, followed by eleven sideswipe, two SMV other, and the remaining one angle collisions. The collision rates have been decreasing since the peak of nine collisions in 2018, with only one being noted during 2022. The detailed collision records outline that the rear end collisions are predominantly due to the congested conditions along Carling Avenue. Weather conditions do not affect collisions at this location. No further examination is required as part of this study.

2.3 Planned Conditions

2.3.1 Changes to the Area Transportation Network

2.3.1.1 *Transportation Master Plan*

The active transportation projects identify separated cycling facilities and/or bike lanes on Clyde Avenue from Carling Avenue to Laperriere Avenue and sidewalk along Tillbury Avenue from Cole Avenue to David Shentow Park. Since these projects have not been scheduled and the implementation of the projects will be paced by available funding, these projects are assumed beyond the study horizon years and will not be included in the report analysis.

2.3.1.2 *Construction and infrastructure projects*

The construction and infrastructure projects identify transit priority along Carling Avenue and includes a dedicated westbound shared bus/bike lane across the frontage of the site. It is anticipated that by the buildout year 2024, the curbside bus lanes will be implemented, and it will be included in the report analysis. The Carling Avenue transit priority measures plan is included in Appendix E.

The City has identified the intersection of Carling Avenue at Churchill Avenue is to be improved to a protected intersection over the next 2-3 years. Additionally, the eastbound and westbound left-turns at the intersection of Clyde Avenue/Cole Avenue are expected to be modified to fully protected left-turn movements as part of planned safety improvements.

2.3.2 Other Study Area Developments

At the time of this report, the following development applications were available for the adjacent properties.

1619-1655 Carling Avenue

The proposed development application includes a site plan for two residential towers, 16-storeys and 18-storeys are proposed for the site with a total of 418 residential units and over 8,000 sq. ft. of commercial/retail space. The development is expected to generate approximately 116 new vehicle trips during the peak. The site is currently under construction, and it will be included in the future conditions. (Parsons, 2022)

1640-1660 Carling Avenue

The proposed development application includes a zoning by-law application and plan of subdivision to redevelop the previous Canadian Tire site with six new residential towers with an estimated 1,700 total units. A new local road will be included through the site and the site is anticipated to proceed through three phases. Phase 1, which consists of 810 units, buildings 5 and 6, is assumed to be constructed by 2026. Phase 2, which consists of 691 units, buildings 2, 3 and 4 is assumed to be constructed by 2031, and Phase 3, which consists of 214 units and building 1 is assumed to be constructed by 2036. The development is expected to generate approximately 391 to 508 new vehicle trips during the peak hours, and a reduction of 100 to 277 vehicle trips with the previous uses being removed. (Parsons, 2022)

1705 Carling Avenue

The proposed development application includes a site plan for replacing an existing motel and restaurant with a 9-storey retirement facility with 158 units and a 22-storey residential high-rise. The development is expected to generate less than 25 vehicle trips during peak hours. The site is currently under construction, and it will be included in the future conditions. (Novatech, 2020)

3 Study Area and Time Periods

3.1 Study Area

As the proposed development is composed of residential units and ground floor retail, the AM and PM peak hours will be examined.

3.2 Time Periods

As the proposed development is composed of residential units and ground floor retail, the AM and PM peak hours will be examined.

3.3 Horizon Years

Construction will occur in a single phase estimated to proceed after 2025, upon completion of a future site plan application.

4 Development-Generated Travel Demand

4.1 Mode Shares

Examining the mode shares recommended in the TRANS Trip Generation Manual (2020) for the subject district, derived from the most recent National Capital Region Origin-Destination survey (OD Survey), the existing average district mode shares by land use for Ottawa West have been summarized in Table 7.

Table 7: TRANS Trip Generation Manual Recommended Mode Shares – Ottawa West

Travel Mode	Multi-Unit (High-Rise)		Commercial Generator	
	AM	PM	AM	PM
Auto Driver	28%	33%	55%	50%
Auto Passenger	11%	11%	11%	16%
Transit	41%	26%	11%	11%
Cycling	3%	7%	0%	5%
Walking	16%	23%	23%	18%
Total	100%	100%	100%	100%

4.2 Trip Generation

This TIA has been prepared using the vehicle and person trip rates for the residential dwellings using the TRANS Trip Generation Manual (2020) and the vehicle trip rates and derived person trip rates for commercial component from the ITE Trip Generation Manual 11th Edition (2021) using the City-prescribed conversion factor of 1.28. Table 8 summarizes the person trip rates for the proposed residential land uses for each peak period and the person trip rates for the non-residential land uses by peak hour.

Table 8: Trip Generation Person Trip Rates

Land Use	Land Use Code	Peak Period	Vehicle Trip Rate	Person Trip Rates
Multi-Unit (High-Rise)	221 & 222 (TRANS)	AM	-	0.80
		PM	-	0.90

Land Use	Land Use Code	Peak Hour	Vehicle Trip Rate	Person Trip Rates
Strip Retail Plaza (<40k)	822 (ITE)	AM	2.36	3.02
		PM	6.59	8.44

Using the above person trip rates, the total person trip generation has been estimated. Table 9 summarizes the total person trip generation.

Table 9: Total Residential Person Trip Generation

Land Use	Units	AM Peak Period			PM Peak Period		
		In	Out	Total	In	Out	Total
Multi-Unit (High-Rise)	370	92	204	296	193	140	333

Land Use	GFA	AM Peak Hour			PM Peak Hour		
		In	Out	Total	In	Out	Total
Strip Retail Plaza (<40k)	3,883 sq.ft	7	5	12	17	17	33

Internal capture rates from the ITE Trip Generation Handbook 3rd Edition have been assigned to the development’s retail component for mixed-use developments. The rates summarized in Table 10 represent the percentage of trips to/from retail use based on the residential component.

Table 10: Internal Capture Rates

Land Use	AM		PM	
	In	Out	In	Out
Residential to/from Strip Retail Plaza (<40k)	17%	14%	10%	26%

Pass-by reductions applied to the retail trip generation at a rate of 40% have been included using the recommended value presented in the ITE Trip Generation Manual 11th Edition (2021) for the most similar land use with a recommended rate, “Retail (40k – 150k sq. ft.)”.

Using the above mode share targets, the internal capture and pass-by rates, and the person trip rates, the person trips by mode have been projected. Trip generation by peak hour has been forecasted using the prescribed peak period conversion factors presented in the TRANS Trip Generation Manual (2020) for the residential component. Table 11 summarizes the residential trip generation and the non-residential trip generation by mode and peak hour.

Table 11: Trip Generation by Mode

Travel Mode		AM Peak Hour				PM Peak Hour			
		Mode Share	In	Out	Total	Mode Share	In	Out	Total
Multi-Unit (High-Rise)	Auto Driver	28%	12	27	39	33%	28	20	48
	Auto Passenger	11%	5	11	16	11%	9	7	16
	Transit	41%	21	46	67	26%	24	17	41
	Cycling	3%	2	3	5	7%	7	5	11
	Walking	16%	9	19	28	23%	23	17	40
Total		100%	49	106	155	100%	91	66	156

Travel Mode		AM Peak Hour				PM Peak Hour			
		Mode Share	In	Out	Total	Mode Share	In	Out	Total
Strip Retail Plaza (<40k)	Auto Driver	55%	0	1	1	50%	1	0	1
	Auto Passenger	11%	1	1	2	16%	3	2	5
	Transit	11%	1	1	2	11%	2	2	4
	Cycling	0%	0	0	0	5%	1	1	2
	Walking	23%	1	1	2	18%	3	3	6
	Internal Capture	varies	-1	0	-1	varies	-1	-3	-4
	Pass-by	40%	-3	-2	-5	40%	-7	-7	-14
	Total	100%	3	4	7	100%	10	8	18
Total	Auto Driver	-	12	28	40	-	29	20	49
	Auto Passenger	-	6	12	18	-	12	9	21
	Transit	-	22	47	69	-	26	19	45
	Cycling	-	2	3	5	-	8	6	13
	Walking	-	10	20	30	-	26	20	46
	Total	-	52	110	162	-	101	74	174

As shown above, a total of 40 AM and 49 PM new peak hour two-way vehicle trips are projected as a result of the proposed development.

4.3 Trip Distribution

To understand the travel patterns of the subject development, the OD Survey has been reviewed to determine the travel, and these patterns were applied based on the build-out of Ottawa West. Table 12 below summarizes the distributions.

Table 12: OD Survey Distribution – Ottawa West

To/From	% of Trips
North	20%
South	35%
East	30%
West	15%
Total	100%

4.4 Trip Assignment

Using the distribution outlined above, turning movement splits, and access to major transportation infrastructure, the trips generated by the site have been assigned to the study area road network. Table 13 summarizes the proportional assignment to the study area roadways, and Figure 12 illustrates the new site generated volumes.

Table 13: Trip Assignment

To/From	Via
North	10% Churchill Ave (N), 10% Carling Ave (E)
South	10% Cole Ave (S), 15% Carling Ave (W), 10% Carling Ave (E)
East	30% Carling Ave (E)
West	15% Carling Ave (W)
Total	100%

Figure 12: New Site Generation Auto Volumes

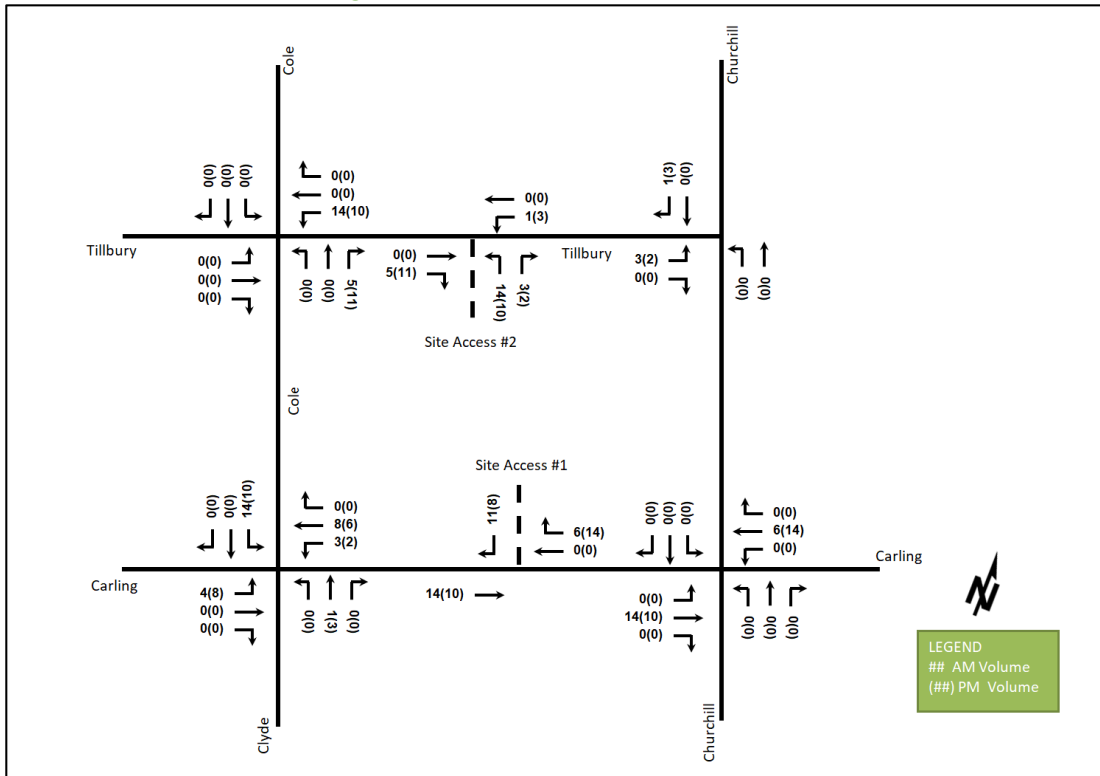

5 Exemption Review

Table 14 summarizes the exemptions for this TIA.

Table 14: Exemption Review

Module	Element	Explanation	Exempt/Required
Site Design and TDM			
Development Design	4.1.2 Circulation and Access	Only required for site plan and zoning by-law applications	Required
	4.1.3 New Street Networks	Only required for plans of subdivision	Exempt
Parking	4.2.1 Parking Supply	Only required for site plan and zoning by-law applications	Required
Boundary Street Design		All applications	Required
Transportation Demand Management	All Elements	Only required when the development generates more than 60 person-trips	Required
Network Impact			
Background Network Travel Demand	All Elements	Only required when one or more other Network Impact Modules are triggered	Exempt
Demand Rationalization		Only required when one or more other Network Impact Modules are triggered	Exempt
Neighbourhood Traffic Calming	4.6.1 Adjacent Neighbourhoods	If the development meets all of the following criteria along the route(s) site generated traffic is expected to utilize	Exempt

Module	Element	Explanation	Exempt/Required
		<p>between an arterial road and the site's access:</p> <ol style="list-style-type: none"> 1. Access to Collector or Local; 2. "Significant sensitive land use presence" exists, where there is at least two of the following adjacent to the subject street segment: <ul style="list-style-type: none"> • School (within 250m walking distance); • Park; • Retirement / Older Adult Facility (i.e. long-term care and retirement homes); • Licenced Child Care Centre; • Community Centre; or • 50%, or greater, of adjacent property along the route(s) is occupied by residential lands and a minimum of 10 occupied residential units are present on the route. 3. Application is for Zoning By-Law Amendment or Draft Plan of Subdivision; 4. At least 75 site-generated auto trips; 5. Site Trip Infiltration is expected. Site traffic will increase peak hour vehicle volumes along the route by 50% or more. 	
Transit	4.7.1 Transit Route Capacity	Only required when the development generates more than 75 transit trips	Exempt
	4.7.2 Transit Priority Requirements	Only required when the development generates more than 75 auto trips	Exempt
Network Concept		Only required when proposed development generates more than 200 person-trips during the peak hour in excess of equivalent volume permitted by established zoning	Exempt
Intersection Design	4.4.1-2/4.9.1 Intersection Control	Only required when the development generates more than 75 auto trips	Exempt
	4.4.3/4.9.2 Intersection Design	Only required when the development generates more than 75 auto trips	Exempt

6 Development Design

6.1 Design for Sustainable Modes

The proposed development includes a mixed-use building with two accesses, a two-way access to Carling Avenue and one to Tillbury Avenue. A total of 202 bicycle parking spaces are proposed, with 198 located within the parking garage and four located on the surface. Hard surface connections are provided from the building entrances to the boundary streets of Carling Avenue and Tillbury Avenue. An existing 2.0-metre sidewalk along Carling Avenue will remain.

The infrastructure TDM checklist is provided in Appendix F.

6.2 Circulation and Access

The access on Carling Avenue will operate as a right-in/right-out access, and the access on Tillbury Avenue will operate as a full movement access. Both accesses are 6.0 metres wide, and the internal aisle through the surface parking is 6.7 metres wide. The surface parking will be located in proximity to the Tillbury Avenue access and the parking garage ramp will be oriented towards the Carling Avenue access. Accesses will connect to both underground and surface parking. The garbage truck and move-in truck turning movements can be accommodated on site. The turning templates are provided in Appendix G.

The TAC Geometric Design Guidelines throat length requirements for an apartment of this size on an arterial road is 40.0 metres, as measured from the end of the corner radii. Access #1 will have a throat length of 36.5 metres from the sidewalk to the underground parking, and it will have a throat length of 50.0 metres from the sidewalk to the surface parking. It is expected that low conflicts will be within the site, therefore, the throat length is supportable at Access #1. Access #2 will have a throat length of 18.5 metres, and no throat length requirement for access on a local road.

The accesses meet the private approach bylaw requirements, and the accesses are expected to be upgraded to meet the existing City standards, currently SC7.1.

7 Parking

7.1 Parking Supply

The site plan proposes 212 vehicle parking spaces, including 161 residential vehicle parking, 36 visitor vehicle parking spaces, and 15 retail vehicle parking. A total of 202 bicycle parking spaces are proposed, including 198 residential bicycle parking and four retail bicycle parking. Among these parking spaces, the 15 retail vehicle parking and four bicycle parking spaces are located at grade and all other parking spaces are located within the parking garage.

From the zoning by-law, the minimum vehicle parking provision for the site is 161 resident parking spaces, 36 visitor parking spaces and no parking requirements for the retail. The minimum bicycle parking provision for the residents is 185 spaces and for the retail is two spaces.

The proposed residential and visitor vehicle parking spaces meets the zoning by-law requirements, and the proposed retail vehicle parking and bicycle parking exceed the zoning by-law requirements.

8 Boundary Street Design

Table 15 summarizes the MMLoS analysis for the boundary streets of Carling Avenue and Tillbury Avenue. Dedicated shared bus/bike lanes are expected to be along the segment of Carling Avenue, and it will be considered

in the future condition. The existing and future conditions for Tillbury Avenue will be the same and is considered in one row. The boundary street analysis for Carling Avenue is based on the land-use designation of “Arterial Main Street” and Tillbury Avenue is based on the land-use designation of “General Urban Area”. The MMLOS worksheets have been provided in Appendix H.

Table 15: Boundary Street MMLOS Analysis

Segment	Pedestrian LOS		Bicycle LOS		Transit LOS		Truck LOS	
	PLOS	Target	BLOS	Target	TLOS	Target	TrLOS	Target
Carling Avenue (Existing)	D	C	F	C	D	C	A	D
Carling Avenue (Future)	D	C	D	C	B	C	A	D
Tillbury Avenue (Existing/Future)	B	C	A	D	N/A	N/A	N/A	N/A

The pedestrian LOS targets will not be met along the segment of Carling Avenue for both existing and future conditions. To meet the theoretical pedestrian LOS targets, Carling Avenue operating speed would need to be lower than 60 km/h for both existing and future conditions.

The bicycle LOS target will not be met along the segment of Carling Avenue for both existing and future conditions. Once the shared bus/bike lanes are implemented, the bicycle LOS will improve from F to D. To meet the theoretical bicycle LOS target C, physically separated facilities would be needed along Carling Avenue for both existing and future conditions.

The transit LOS target is not met along the segment of Carling Avenue for the existing condition, but it will be met in the future condition once the shared bus/bike lanes are implemented.

9 Transportation Demand Management

9.1 Context for TDM

The mode shares used within the TIA represent the unmodified district mode shares and represent a conservative assessment in the context of the future Carling Avenue bus lanes. Overall, the modal shares are likely to be achieved and supporting TDM measures should be provided to encourage shifts towards sustainable modes.

The subject site is not within a design priority area. The total bedroom count within the development is subject to the final unit breakdown and layout selections by purchasers. No age restrictions are noted.

9.2 Need and Opportunity

The subject site has been assumed to rely predominantly on auto travel and transit and those assumptions have been carried through the analysis. As the unmodified district mode shares have been applied, and as they are considered conservative for analysis purposes, the risks of failing to meet mode share targets are low.

9.3 TDM Program

The “suite of post occupancy TDM measures” has been summarized in the TDM checklists for the residential land uses. The checklist is provided in Appendix F. The key TDM measures recommended include:

- Display area walking, cycling, and transit maps with route schedules
- Contract with providers to install on-site bikeshare (or other micromobility alternatives) and carshare spaces
- Inclusion of a 1-year Presto card for first time new townhome purchase, with a set time frame for this offer (e.g. 6-months) from the initial opening of the site
- Unbundle parking cost from purchase or rental costs

- Provide a multimodal travel option information package to new residents

10 Summary of Improvements Indicated and Modifications Options

The following summarizes the analysis and results presented in this TIA report:

Proposed Site and Screening

- The proposed development concept consists of a mixed-use building including 370 residential units, 3,883 square feet retail space, 212 vehicle parking spaces, and 202 bicycle parking spaces
- The accesses will be located approximately at the existing access on Carling Avenue and existing residential driveway on Tillbury Avenue
- Construction will occur in a single phase estimated to proceed after 2025, upon completion of a future site plan application
- The trip generation and safety triggers were met for the TIA Screening

Existing Conditions

- Carling Avenue is an arterial road, Churchill Avenue is a major collector road, and Clyde Avenue, Cole Avenue, and Tillbury Avenue are local roads in the study area
- Sidewalks are provided along both sides of Carling Avenue, Churchill Avenue north of Carling Avenue, and a section of Cole Avenue, with sidewalks on a single side on various local road
- Cycletracks are provided along Churchill Avenue north of Carling Avenue with suggested bike routes through the communities to the north and south of Carling Avenue
- Carling Avenue is designated a spine route
- Within the study area, the intersection of Carling Avenue at Clyde Avenue/Cole Avenue and Carling Avenue at Churchill Avenue are noted to have experienced higher collisions than other intersections
- The detailed collision records for Carling Avenue at Clyde Avenue/Cole Avenue intersection outline that turning movement collisions are predominantly due to the eastbound and westbound left-turn movements interacting with the opposing westbound and eastbound through movements
- Higher number of collisions were noted in 2018 at the intersection of Carling Avenue at Clyde Avenue/Cole Avenue, which may be related to the resurfacing/roadworks undertaken in 2018 into 2019
- At Carling Avenue at Churchill Avenue intersection, the collision rates have been decreasing since the peak of nine collisions in 2018, with only one being noted during 2022
- The collisions along the frontage do not appear to be related to the existing accesses, and may be a function of loading activities or stoppings on the curb side lane of Carling Avenue
- No further collision examination is required as part of this study

Planned Conditions

- Separated cycling facilities and/or bike lanes on Clyde Avenue from Carling Avenue to Laperriere Avenue and sidewalk along Tillbury Avenue from Cole Avenue to David Shentow Park in the active transportation projects lists will not be included in the report analysis because these projects have not been scheduled
- The construction and infrastructure projects identify transit priority along Carling Avenue and include a dedicated westbound bus lane across the frontage of the site, which will be included in the report analysis
- The City has identified the intersection of Carling Avenue at Churchill Avenue is to be improved to a protected intersection over the next 2-3 years. Additionally, the eastbound and westbound left-turns at

the intersection of Clyde Avenue/Cole Avenue are expected to be modified to fully protected left-turn movements as part of planned safety improvements

Development Generated Travel Demand

- The proposed development is forecasted to produce 162 two-way people trips during the AM peak hour and 174 two-way people trips during the PM peak hour
- Of the forecasted people trips, 40 two-way trips will be vehicle trips during the AM peak hour and 49 two-way trips will be vehicle trips during the PM peak hour
- Of the forecasted people trips, 69 two-way trips will be transit trips during the AM peak hour and 45 two-way trips will be transit trips during the PM peak hour
- Of the forecasted trips, 20% are anticipated to travel north, 35% to the south, 30% to the east, and 15% to the west

Development Design

- The site is proposed with two accesses, one located at the existing Carling Avenue access and the other replacing the residential driveway on Tillbury Avenue
- The accesses will operate as right-in/right-out along Carling Avenue and full movements on Tillbury Avenue, with surface parking located near Tillbury Avenue and the underground parking ramp oriented towards Carling Avenue
- The accesses are currently identified to be 6.0 metres wide and the drive aisle through the surface parking area is 6.7 metres wide
- The throat length is supportable at Access #1, and no throat length requirement for Access #2
- The accesses meet the private approach bylaw requirements
- The accesses are expected to conform to the City SC7.1 specification
- Bicycle parking is located within the underground parking levels and four of the 202 spaces on the surface
- Hard surface connections are provided from the building entrances to the boundary streets of Carling Avenue and Tillbury Avenue and surround the site
- An existing 2.0-metre sidewalk along Carling Avenue will remain
- The garbage truck and move-in truck turning movements can be accommodated on site

Parking

- The site plan proposes a total of 212 vehicle parking spaces, including 161 residential parking, 36 visitor parking, and 15 retail parking spaces
- A total of 198 residential bicycle parking and four retail bicycle parking are proposed
- The proposed residential and visitor vehicle parking spaces meets the zoning by-law requirements
- The retail vehicle parking and bicycle parking exceed the zoning by-law requirements

Boundary Street Design

- The pedestrian LOS target will not be met along the segment of Carling Avenue for both existing and future conditions, and the operating speed would need to be lower than 60 km/h to meet the pedestrian LOS target
- The bicycle LOS target will not be met along the segment of Carling Avenue for both existing and future conditions, but it will improve from F to D with shared bus/bike lane provided in the future condition

- Physically separated facilities would be needed along the segment of Carling Avenue to meet the bicycle LOS target C for both existing and future conditions
- The transit LOS target is not met along the segment of Carling Avenue for the existing condition, but it will be met in the future condition with shared bus/bike lane provided

TDM

- Supportive TDM measures to be included within the proposed development should include:
 - Display area walking, cycling, and transit maps with route schedules
 - Contract with providers to install on-site bikeshare (or other micromobility alternatives) and carshare spaces
 - Inclusion of a 1-year Presto card for first time new townhome purchase, with a set time frame for this offer (e.g. 6-months) from the initial opening of the site
 - Unbundle parking cost from purchase or rental costs
 - Provide a multimodal travel option information package to new residents

11 Conclusion

It is recommended that, from a transportation perspective, the proposed development applications proceed.

Prepared By:



Yu-Chu Chen
Transportation Engineering-Intern

Reviewed By:



Andrew Harte, P.Eng.
Senior Transportation Engineer

Appendix A

TIA Screening Form and PM Certification Form

City of Ottawa 2017 TIA Guidelines
Step 1 - Screening Form

Date: 30-Jun-23
Project Number: 2023-083
1657-1673 Carling Avenue and
Project Reference: 386 Tillbury Avenue

1.1 Description of Proposed Development	
Municipal Address	1657-1673 Carling Avenue, 386 Tillbury Avenue
Description of Location	Approximately 65 metres east of Carling Avenue at Clyde Avenue/Cole Avenue intersection
Land Use Classification	Arterial Mainstreet (AM10) for the Carling Avenue parcels and Residential Fourth Density (R4UC) for the Tillbury Avenue parcel
Development Size	25-storey mixed-use building
Accesses	Access is proposed via Tillbury Avenue
Phase of Development	Single
Buildout Year	2025
TIA Requirement	Full TIA Required

1.2 Trip Generation Trigger	
Land Use Type	Townhomes or apartments
Development Size	295 Units
Trip Generation Trigger	Yes

1.3 Location Triggers	
Does the development propose a new driveway to a boundary street that is designated as part of the City's Transit Priority, Rapid Transit or Spine Bicycle Networks?	No
Is the development in a Design Priority Area (DPA) or Transit-oriented Development (TOD) zone?	No
Location Trigger	No

1.4. Safety Triggers	
Are posted speed limits on a boundary street 80 km/hr or greater?	No
Are there any horizontal/vertical curvatures on a boundary street limits sight lines at a proposed driveway?	No
Is the proposed driveway within the area of influence of an adjacent traffic signal or roundabout (i.e. within 300 m of intersection in rural conditions, or within 150 m of intersection in urban/ suburban conditions)?	No
Is the proposed driveway within auxiliary lanes of an intersection?	No
Does the proposed driveway make use of an existing median break that serves an existing site?	No
Is there is a documented history of traffic operations or safety concerns on the boundary streets within 500 m of the development?	Yes High collisions at the intersections of Carling Avenue at Clyde Avenue/Cole Avenue and Carling Avenue at Churchill Avenue
Does the development include a drive-thru facility?	No
Safety Trigger	Yes



TIA Plan Reports

On 14 June 2017, the Council of the City of Ottawa adopted new Transportation Impact Assessment (TIA) Guidelines. In adopting the guidelines, Council established a requirement for those preparing and delivering transportation impact assessments and reports to sign a letter of certification.

Individuals submitting TIA reports will be responsible for all aspects of development-related transportation assessment and reporting, and undertaking such work, in accordance and compliance with the City of Ottawa's Official Plan, the Transportation Master Plan and the Transportation Impact Assessment (2017) Guidelines.

By submitting the attached TIA report (and any associated documents) and signing this document, the individual acknowledges that s/he meets the four criteria listed below.

CERTIFICATION

1. I have reviewed and have a sound understanding of the objectives, needs and requirements of the City of Ottawa's Official Plan, Transportation Master Plan and the Transportation Impact Assessment (2017) Guidelines;
2. I have a sound knowledge of industry standard practice with respect to the preparation of transportation impact assessment reports, including multi modal level of service review;
3. I have substantial experience (more than 5 years) in undertaking and delivering transportation impact studies (analysis, reporting and geometric design) with strong background knowledge in transportation planning, engineering or traffic operations; and
4. I am either a licensed¹ or registered² professional in good standing, whose field of expertise [check appropriate field(s)] is either transportation engineering or transportation planning .

1,2 License of registration body that oversees the profession is required to have a code of conduct and ethics guidelines that will ensure appropriate conduct and representation for transportation planning and/or transportation engineering works.

City Of Ottawa
Infrastructure Services and Community
Sustainability
Planning and Growth Management
110 Laurier Avenue West, 4th fl.
Ottawa, ON K1P 1J1
Tel. : 613-580-2424
Fax: 613-560-6006

Ville d'Ottawa
Services d'infrastructure et Viabilité des
collectivités
Urbanisme et Gestion de la croissance
110, avenue Laurier Ouest
Ottawa (Ontario) K1P 1J1
Tél. : 613-580-2424
Télécopieur: 613-560-6006

Dated at Ottawa this 20 day of September, 2018.
(City)

Name: Andrew Harte
(Please Print)

Professional Title: Professional Engineer



Signature of Individual certifier that s/he meets the above four criteria

Office Contact Information (Please Print)
Address: 6 Plaza Court
City / Postal Code: Ottawa / K2H 7W1
Telephone / Extension: (613) 697-3797
E-Mail Address: Andrew.Harte@CGHTransportation.com



Appendix B

Turning Movement Counts



Transportation Services - Traffic Services

Turning Movement Count - Peak Hour Diagram

CARLING AVE @ CLYDE AVE/COLE AVE

Survey Date: Wednesday, February 23, 2022

Start Time: 07:00

WO No: 40170

Device: Miovision

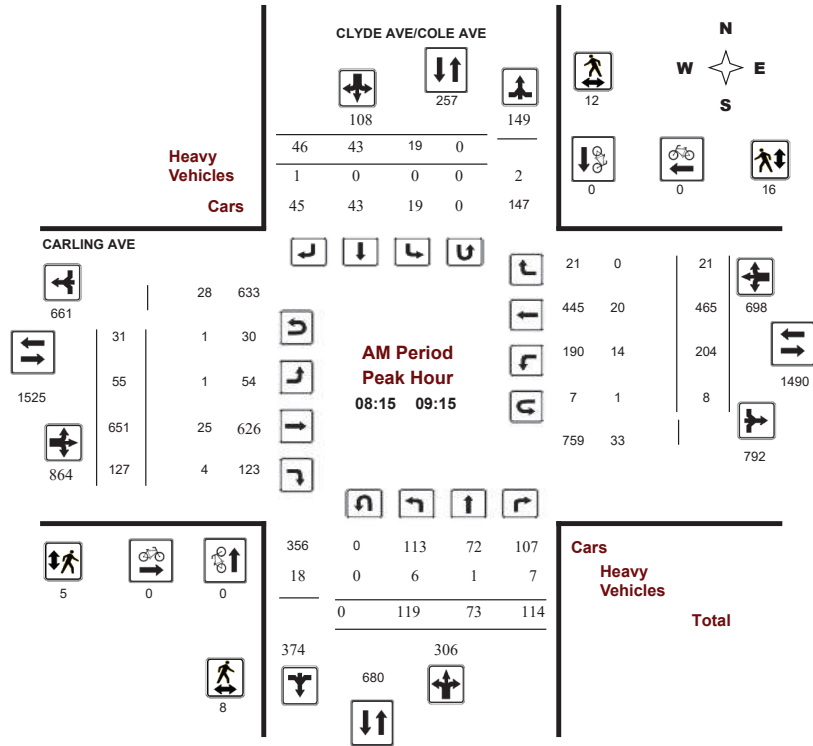

Comments



Transportation Services - Traffic Services

Turning Movement Count - Peak Hour Diagram

CARLING AVE @ CLYDE AVE/COLE AVE

Survey Date: Wednesday, February 23, 2022

Start Time: 07:00

WO No: 40170

Device: Miovision

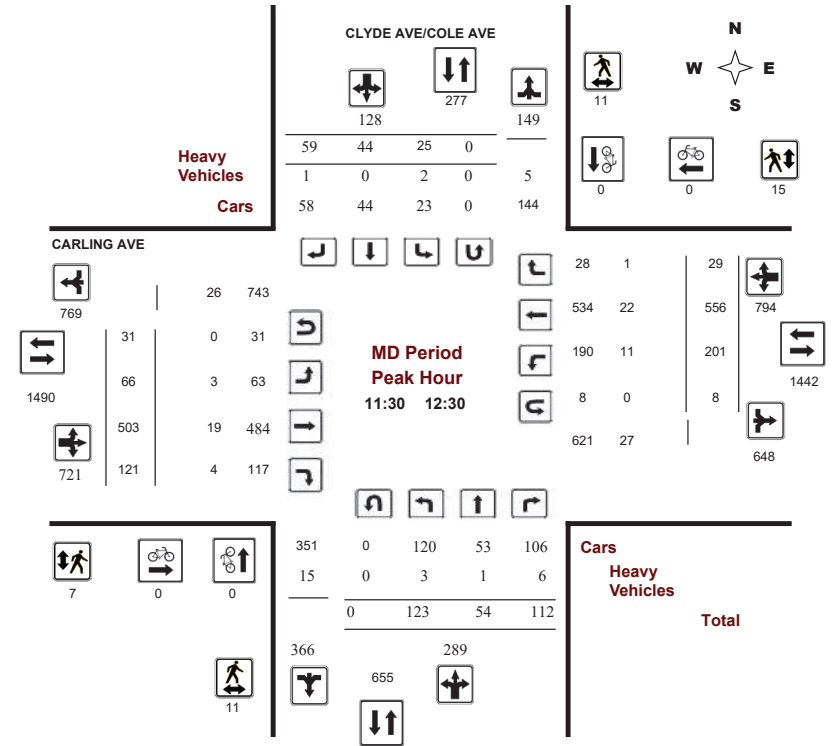

Comments



Transportation Services - Traffic Services

Turning Movement Count - Peak Hour Diagram CARLING AVE @ CLYDE AVE/COLE AVE

Survey Date: Wednesday, February 23, 2022
Start Time: 07:00

WO No: 40170
Device: Miovision

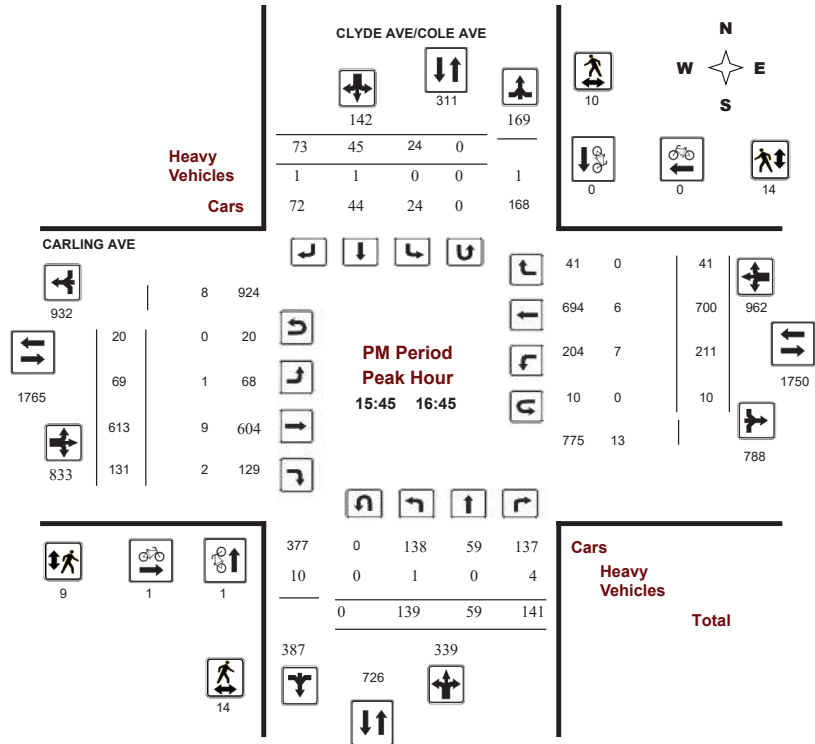

Comments



Transportation Services - Traffic Services

Turning Movement Count - Study Results CARLING AVE @ CLYDE AVE/COLE AVE

Survey Date: Wednesday, February 23, 2022
Start Time: 07:00

WO No: 40170
Device: Miovision

Full Study Summary (8 HR Standard)

Survey Date: Wednesday, February 23, 2022

Total Observed U-Turns
Northbound: 0 Southbound: 0
Eastbound: 159 Westbound: 65

AADT Factor
1.00

Period	CLYDE AVE/COLE AVE								CARLING AVE								WB TOT	STR TOT	Grand Total
	Northbound				Southbound				Eastbound				Westbound						
	LT	ST	RT	NB TOT	LT	ST	RT	SB TOT	LT	ST	RT	EB TOT	LT	ST	RT	WB TOT			
07:00-08:00	49	22	52	123	11	18	25	54	177	35	522	67	624	142	300	8	450	1074	1251
08:00-09:00	123	66	87	276	17	39	49	105	381	58	663	131	852	205	461	18	684	1536	1917
09:00-10:00	80	30	122	232	12	27	38	77	309	61	529	95	685	183	410	24	617	1302	1611
11:30-12:30	123	54	112	289	25	44	59	128	417	66	503	121	690	201	556	29	786	1476	1893
12:30-13:30	124	48	130	302	25	44	43	112	414	68	503	114	685	187	551	19	757	1442	1856
15:00-16:00	131	78	141	350	29	40	40	109	459	55	619	139	813	180	689	26	895	1708	2167
16:00-17:00	142	59	132	333	22	47	74	143	476	70	573	122	765	195	700	42	937	1702	2178
17:00-18:00	129	68	112	309	23	43	55	121	430	65	506	139	710	169	625	40	834	1544	1974
Sub Total	901	425	888	2214	164	302	383	849	3063	478	4418	928	5824	1462	4292	206	5960	11784	14847
U Turns				0				0	0				159				65	224	224
Total	901	425	888	2214	164	302	383	849	3063	478	4418	928	5983	1462	4292	206	6025	12008	15071
EQ 12Hr	1252	591	1234	3077	228	420	532	1180	4258	664	6141	1290	8316	2032	5966	286	8375	16691	20949
Note: These values are calculated by multiplying the totals by the appropriate expansion factor.													1.39						
AVG 12Hr	1252	591	1234	3077	228	550	697	1180	4258	664	6141	1290	8316	2032	5966	286	8375	16691	20949
Note: These volumes are calculated by multiplying the Equivalent 12 hr. totals by the AADT factor.													1.00						
AVG 24Hr	1640	774	1617	4031	299	720	913	1546	5578	870	8045	1690	10894	2662	7815	375	10971	21865	27443
Note: These volumes are calculated by multiplying the Average Daily 12 hr. totals by 12 to 24 expansion factor.													1.31						
Note: U-Turns provided for approach totals. Refer to 'U-Turn' Report for specific breakdown.																			



Transportation Services - Traffic Services

Turning Movement Count - Study Results
CARLING AVE @ CLYDE AVE/COLE AVE

Survey Date: Wednesday, February 23, 2022
Start Time: 07:00

WO No: 40170
Device: Miovision

Full Study 15 Minute Increments

Table with columns for Time Period, Northbound, Southbound, Eastbound, Westbound, and Grand Total. Rows represent 15-minute intervals from 07:00 to 17:45.

Note: U-Turns are included in Totals.



Transportation Services - Traffic Services

Turning Movement Count - Study Results
CARLING AVE @ CLYDE AVE/COLE AVE

Survey Date: Wednesday, February 23, 2022
Start Time: 07:00

WO No: 40170
Device: Miovision

Full Study Cyclist Volume

Table with columns for Time Period, Northbound, Southbound, Street Total, Eastbound, Westbound, Street Total, and Grand Total. Rows represent 15-minute intervals from 07:00 to 17:45.



Transportation Services - Traffic Services

Turning Movement Count - Study Results

CARLING AVE @ CLYDE AVE/COLE AVE

Survey Date: Wednesday, February 23, 2022

WO No: 40170

Start Time: 07:00

Device: Miovision

Full Study Pedestrian Volume

CLYDE AVE/COLE AVE CARLING AVE

Table with 8 columns: Time Period, NB Approach, SB Approach, Total, EB Approach, WB Approach, Total, Grand Total. Rows show pedestrian counts for various time intervals from 07:00 to 17:45.



Transportation Services - Traffic Services

Turning Movement Count - Study Results

CARLING AVE @ CLYDE AVE/COLE AVE

Survey Date: Wednesday, February 23, 2022

WO No: 40170

Start Time: 07:00

Device: Miovision

Full Study Heavy Vehicles

CLYDE AVE/COLE AVE CARLING AVE

Table with 20 columns: Time Period, Northbound (LT, ST, RT, N TOT), Southbound (LT, ST, RT, S TOT, STR TOT), Eastbound (LT, ST, RT, E TOT), Westbound (LT, ST, RT, W TOT, STR TOT), Grand Total. Rows show heavy vehicle counts for various time intervals from 07:00 to 17:45.



Transportation Services - Traffic Services

Turning Movement Count - Study Results

CARLING AVE @ CLYDE AVE/COLE AVE

Survey Date: Wednesday, February 23, 2022

WO No: 40170

Start Time: 07:00

Device: Miovision

Full Study 15 Minute U-Turn Total

Time Period	CLYDE AVE/COLE AVE		CARLING AVE		Total
	Northbound U-Turn Total	Southbound U-Turn Total	Eastbound U-Turn Total	Westbound U-Turn Total	
07:00 - 07:15	0	0	3	2	5
07:15 - 07:30	0	0	4	0	4
07:30 - 07:45	0	0	1	2	3
07:45 - 08:00	0	0	6	0	6
08:00 - 08:15	0	0	2	0	2
08:15 - 08:30	0	0	10	4	14
08:30 - 08:45	0	0	7	2	9
08:45 - 09:00	0	0	6	1	7
09:00 - 09:15	0	0	8	1	9
09:15 - 09:30	0	0	2	1	3
09:30 - 09:45	0	0	3	1	4
09:45 - 10:00	0	0	5	1	6
11:30 - 11:45	0	0	6	2	8
11:45 - 12:00	0	0	9	1	10
12:00 - 12:15	0	0	6	1	7
12:15 - 12:30	0	0	10	4	14
12:30 - 12:45	0	0	2	2	4
12:45 - 13:00	0	0	5	3	8
13:00 - 13:15	0	0	4	2	6
13:15 - 13:30	0	0	5	4	9
15:00 - 15:15	0	0	3	1	4
15:15 - 15:30	0	0	3	2	5
15:30 - 15:45	0	0	2	0	2
15:45 - 16:00	0	0	1	2	3
16:00 - 16:15	0	0	6	2	8
16:15 - 16:30	0	0	4	4	8
16:30 - 16:45	0	0	9	2	11
16:45 - 17:00	0	0	5	1	6
17:00 - 17:15	0	0	2	8	10
17:15 - 17:30	0	0	12	0	12
17:30 - 17:45	0	0	5	5	10
17:45 - 18:00	0	0	3	4	7
Total	0	0	159	65	224



Transportation Services - Traffic Services

Turning Movement Count - Full Study Peak Hour Diagram

CARLING AVE @ CHURCHILL AVE

Survey Date: Tuesday, April 25, 2017

WO No: 36955

Start Time: 07:00

Device: Miovision

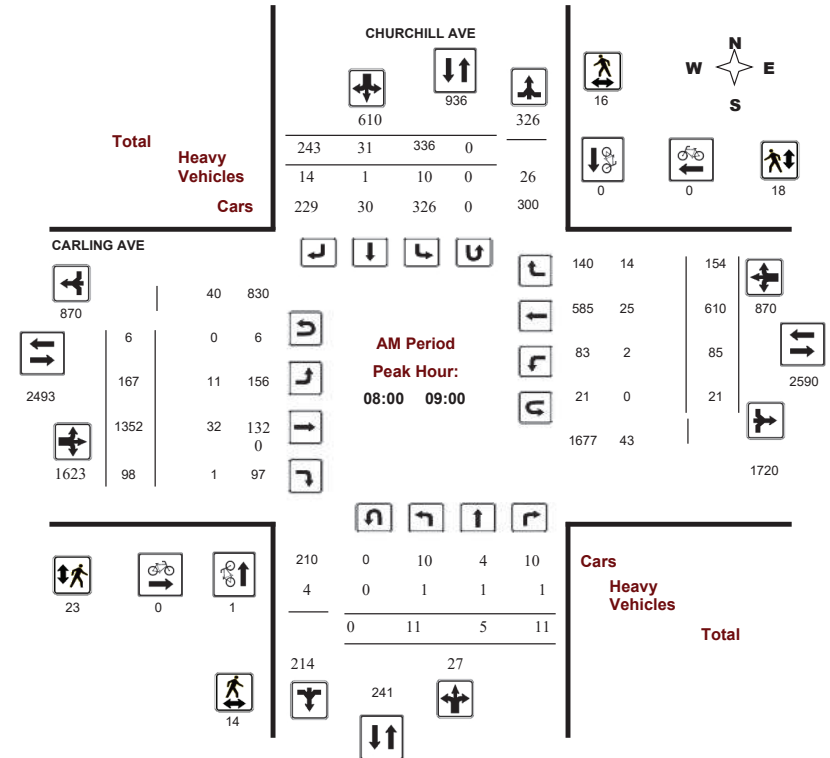



Transportation Services - Traffic Services

Turning Movement Count - Full Study Peak Hour Diagram

CARLING AVE @ CHURCHILL AVE

Survey Date: Tuesday, April 25, 2017
Start Time: 07:00

WO No: 36955
Device: Miovision

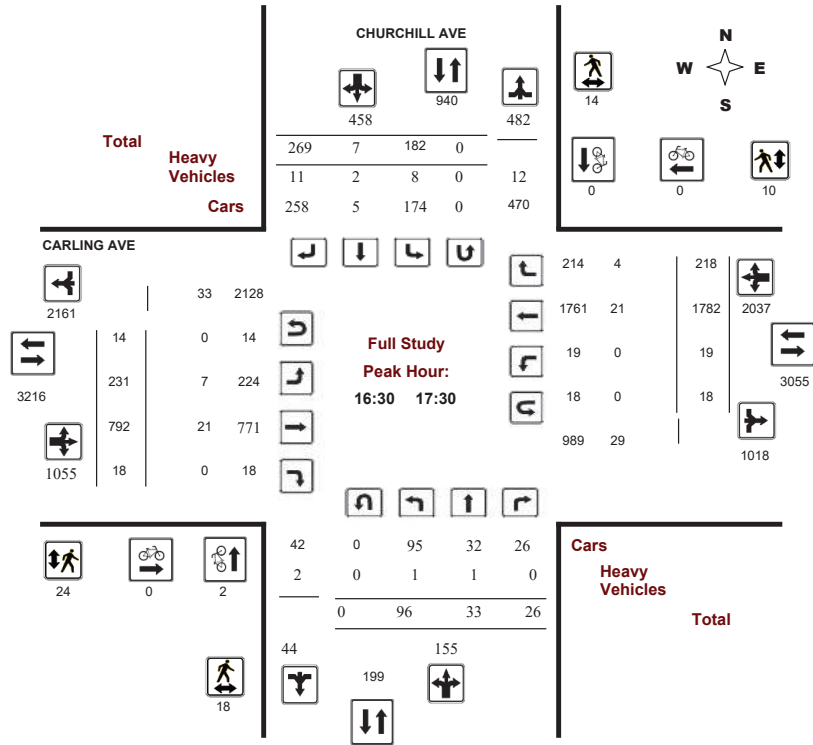

Comments



Transportation Services - Traffic Services

Turning Movement Count - Full Study Peak Hour Diagram

CARLING AVE @ CHURCHILL AVE

Survey Date: Tuesday, April 25, 2017
Start Time: 07:00

WO No: 36955
Device: Miovision

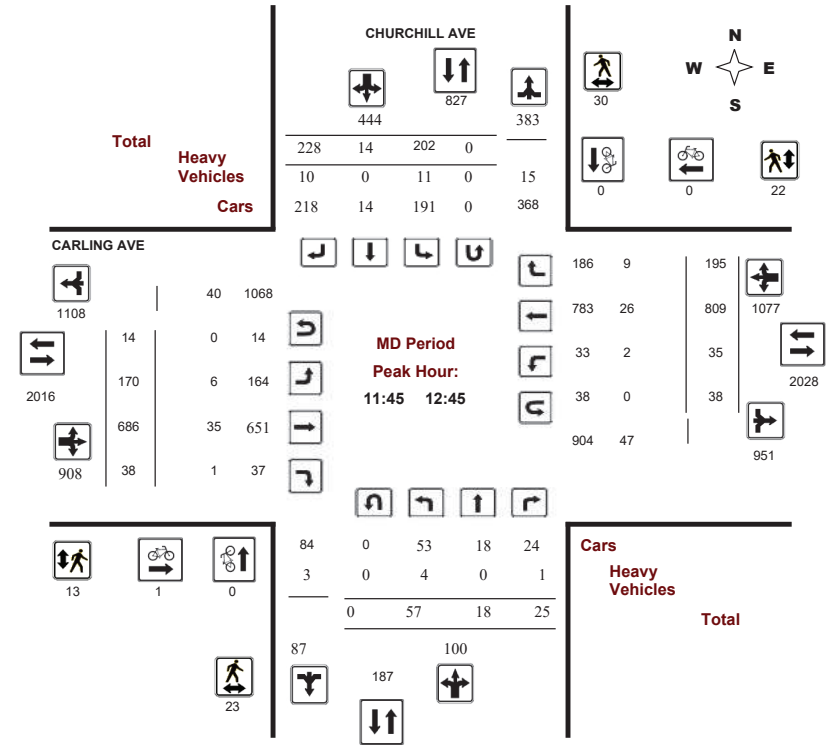

Comments



Transportation Services - Traffic Services

Turning Movement Count - Full Study Peak Hour Diagram

CARLING AVE @ CHURCHILL AVE

Survey Date: Tuesday, April 25, 2017
Start Time: 07:00

WO No: 36955
Device: Miovision

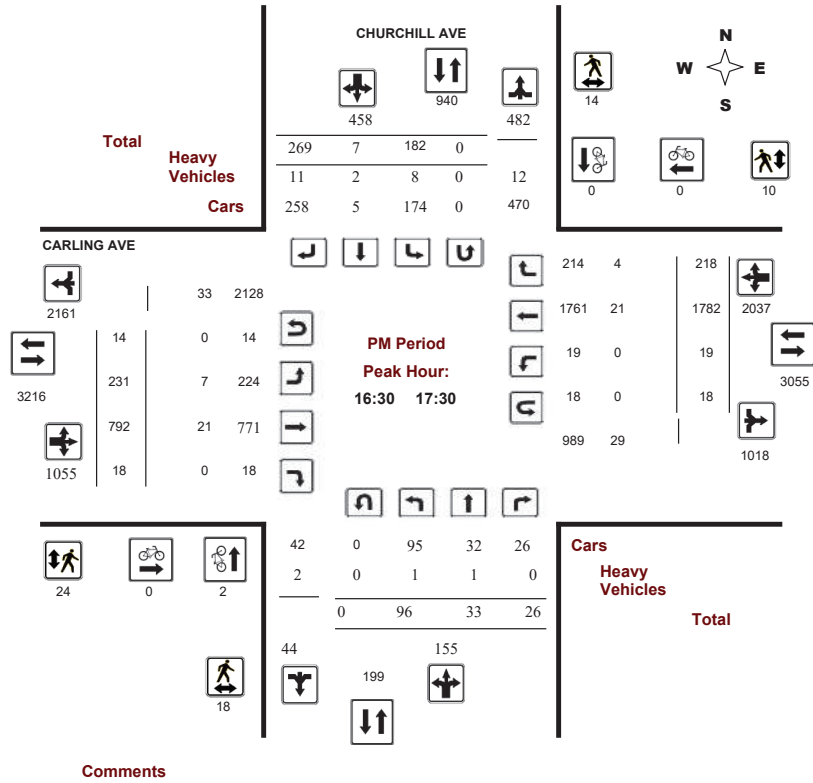

Transportation Services - Traffic Services

Turning Movement Count - Full Study Diagram

CARLING AVE @ CHURCHILL AVE

Survey Date: Tuesday, April 25, 2017

WO#: 36955
Device: Miovision

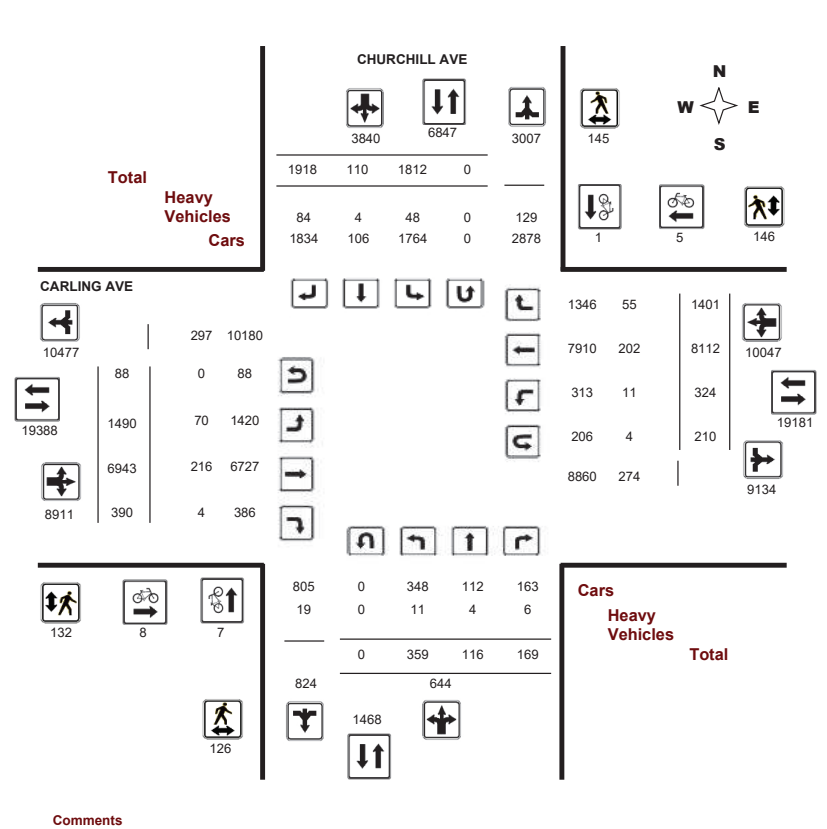



Transportation Services - Traffic Services

Work Order 36955

Turning Movement Count - Full Study Summary Report

CARLING AVE @ CHURCHILL AVE

Survey Date: Tuesday, April 25, 2017

Total Observed U-Turns: Northbound: 0, Southbound: 0, Eastbound: 88, Westbound: 210. AADT Factor: .90

Full Study

Table with columns for CHURCHILL AVE (Northbound, Southbound) and CARLING AVE (Eastbound, Westbound). Rows include Period, U Turns, EQ 12Hr, AVG 12Hr, and AVG 24Hr. Includes sub-totals and grand totals.

Comments: Note: U-Turns provided for approach totals. Refer to 'U-Turn' Report for specific breakdown.



Transportation Services - Traffic Services

W.O. 36955

Turning Movement Count - 15 Minute Summary Report

CARLING AVE @ CHURCHILL AVE

Survey Date: Tuesday, April 25, 2017

Total Observed U-Turns: Northbound: 0, Southbound: 0, Eastbound: 88, Westbound: 210

Table with columns for CHURCHILL AVE (Northbound, Southbound) and CARLING AVE (Eastbound, Westbound). Rows include Time Period and various traffic counts (LT, ST, RT, N TOT, S TOT, E TOT, W TOT, Grand Total).

TOTAL: 359 116 169 644 1812 110 1918 3840 4484 1490 6943 390 8911 324 8112 1401 10047 18958 23442. Note: U-Turns are included in Totals. Comment:



Transportation Services - Traffic Services
Turning Movement Count - Cyclist Volume Report

Work Order
36955

CARLING AVE @ CHURCHILL AVE

Count Date: Tuesday, April 25, 2017

Start Time: 07:00

Time Period	CHURCHILL AVE			CARLING AVE			Grand Total
	Northbound	Southbound	Street Total	Eastbound	Westbound	Street Total	
07:00 08:00	0	0	0	2	1	3	3
08:00 09:00	1	0	1	0	0	0	1
09:00 10:00	2	1	3	2	0	2	5
11:30 12:30	0	0	0	0	1	1	1
12:30 13:30	0	0	0	3	1	4	4
15:00 16:00	2	0	2	1	1	2	4
16:00 17:00	0	0	0	0	1	1	1
17:00 18:00	2	0	2	0	0	0	2
Total	7	1	8	8	5	13	21

Comment:



Transportation Services - Traffic Services
Turning Movement Count - Heavy Vehicle Report

W.O.
36955

CARLING AVE @ CHURCHILL AVE

Survey Date: Tuesday, April 25, 2017

Time Period	CHURCHILL AVE								CARLING AVE								Grand Total		
	Northbound				Southbound				Eastbound				Westbound						
	LT	ST	RT	N TOT	LT	ST	RT	S TOT	STR TOT	LT	ST	RT	E TOT	LT	ST	RT		W TOT	STR TOT
07:00 08:00	0	0	0	0	6	0	8	14	14	16	22	0	38	1	22	9	33	71	85
08:00 09:00	1	1	1	3	10	1	14	25	28	11	32	1	44	2	25	14	41	85	113
09:00 10:00	2	1	3	6	7	0	9	16	22	9	34	2	45	6	25	5	38	83	105
11:30 12:30	5	0	0	5	10	0	10	20	25	10	29	1	40	2	34	13	49	89	114
12:30 13:30	1	0	1	2	2	0	13	15	17	6	35	0	41	0	31	3	35	76	93
15:00 16:00	0	1	1	2	4	0	11	15	17	7	24	0	31	0	26	5	31	62	79
16:00 17:00	1	0	0	1	2	3	9	14	15	7	23	0	30	0	23	3	26	56	71
17:00 18:00	1	1	0	2	7	0	10	17	19	4	17	0	21	0	16	3	19	40	59
Sub Total	11	4	6	21	48	4	84	136	157	70	216	4	290	11	202	55	272	562	719
U-Turns (Heavy Vehicles)	0				0				0				0				4	4	4
Total	11	4	6	0	48	4	84	136	157	70	216	4	290	11	202	55	276	566	723

Heavy Vehicles include Buses, Single-Unit Trucks and Articulated Trucks. Further, they ARE included in the Turning Movement Count Summary.

Note: These volumes consists of bicycles only (no mopeds or motorcycles) and ARE NOT included in the Turning Movement Count Summary.



Transportation Services - Traffic Services

Work Order
36955

Turning Movement Count - Pedestrian Volume Report

CARLING AVE @ CHURCHILL AVE

Count Date: Tuesday, April 25, 2017

Start Time: 07:00

Time Period	NB Approach (E or W Crossing)	SB Approach (E or W Crossing)	Total	EB Approach (N or S Crossing)	WB Approach (N or S Crossing)	Total	Grand Total
07:00 07:15	3	3	6	1	4	5	11
07:15 07:30	3	5	8	6	7	13	21
07:30 07:45	4	2	6	2	5	7	13
07:45 08:00	1	2	3	5	5	10	13
07:00 08:00	11	12	23	14	21	35	58
08:00 08:15	1	2	3	5	3	8	11
08:15 08:30	5	3	8	6	4	10	18
08:30 08:45	4	3	7	8	4	12	19
08:45 09:00	4	8	12	4	7	11	23
08:00 09:00	14	16	30	23	18	41	71
09:00 09:15	3	4	7	7	2	9	16
09:15 09:30	1	5	6	2	7	9	15
09:30 09:45	5	5	10	3	7	10	20
09:45 10:00	1	3	4	0	3	3	7
09:00 10:00	10	17	27	12	19	31	58
11:30 11:45	4	5	9	5	6	11	20
11:45 12:00	2	9	11	1	5	6	17
12:00 12:15	4	7	11	2	6	8	19
12:15 12:30	9	9	18	5	2	7	25
11:30 12:30	19	30	49	13	19	32	81
12:30 12:45	8	5	13	5	9	14	27
12:45 13:00	8	6	14	6	9	15	29
13:00 13:15	9	3	12	6	6	12	24
13:15 13:30	3	4	7	2	6	8	15
12:30 13:30	28	18	46	19	30	49	95
15:00 15:15	2	5	7	2	4	6	13
15:15 15:30	5	6	11	8	4	12	23
15:30 15:45	10	2	12	3	4	7	19
15:45 16:00	1	3	4	3	2	5	9
15:00 16:00	18	16	34	16	14	30	64
16:00 16:15	2	4	6	3	3	6	12
16:15 16:30	5	6	11	3	6	9	20
16:30 16:45	1	7	8	5	3	8	16
16:45 17:00	3	1	4	3	1	4	8
16:00 17:00	11	18	29	14	13	27	56
17:00 17:15	6	4	10	9	4	13	23
17:15 17:30	8	2	10	7	2	9	19
17:30 17:45	1	7	8	4	4	8	16
17:45 18:00	0	5	5	1	2	3	8
17:00 18:00	15	18	33	21	12	33	66
Total	126	145	271	132	146	278	549

Comment:



Transportation Services - Traffic Services

Work Order
36955

Turning Movement Count - 15 Min U-Turn Total Report

CARLING AVE @ CHURCHILL AVE

Survey Date: Tuesday, April 25, 2017

Time Period	Northbound U-Turn Total	Southbound U-Turn Total	Eastbound U-Turn Total	Westbound U-Turn Total	Total
07:00 07:15	0	0	1	3	4
07:15 07:30	0	0	2	2	4
07:30 07:45	0	0	1	9	10
07:45 08:00	0	0	1	5	6
08:00 08:15	0	0	1	4	5
08:15 08:30	0	0	2	7	9
08:30 08:45	0	0	2	7	9
08:45 09:00	0	0	1	3	4
09:00 09:15	0	0	2	9	11
09:15 09:30	0	0	2	6	8
09:30 09:45	0	0	4	7	11
09:45 10:00	0	0	3	10	13
11:30 11:45	0	0	1	13	14
11:45 12:00	0	0	5	15	20
12:00 12:15	0	0	4	7	11
12:15 12:30	0	0	4	9	13
12:30 12:45	0	0	1	7	8
12:45 13:00	0	0	4	7	11
13:00 13:15	0	0	2	9	11
13:15 13:30	0	0	3	14	17
15:00 15:15	0	0	4	7	11
15:15 15:30	0	0	5	7	12
15:30 15:45	0	0	4	7	11
15:45 16:00	0	0	2	4	6
16:00 16:15	0	0	3	3	6
16:15 16:30	0	0	1	3	4
16:30 16:45	0	0	7	8	15
16:45 17:00	0	0	2	4	6
17:00 17:15	0	0	2	3	5
17:15 17:30	0	0	3	3	6
17:30 17:45	0	0	6	2	8
17:45 18:00	0	0	2	7	9
Total	0	0	88	210	298



Turning Movement Count Summary, AM and PM Peak Hour Flow Diagrams

Automobiles, Taxis, Light Trucks, Vans, SUVs, Motorcycles, Heavy Trucks, Buses, and School Buses

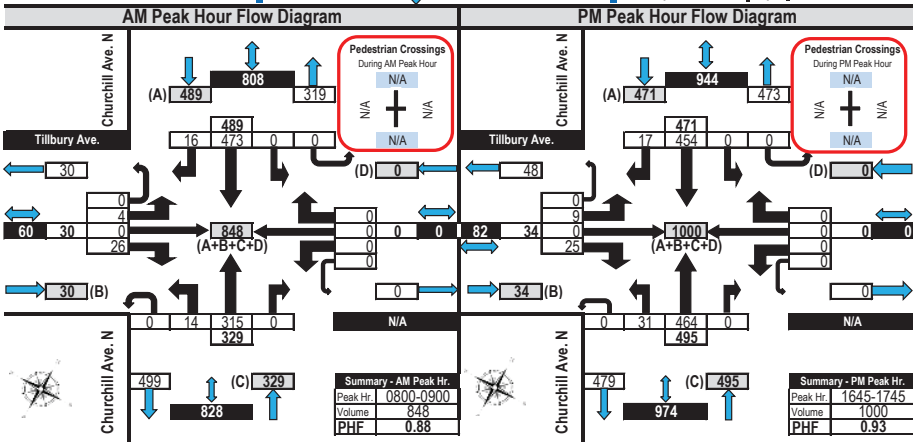
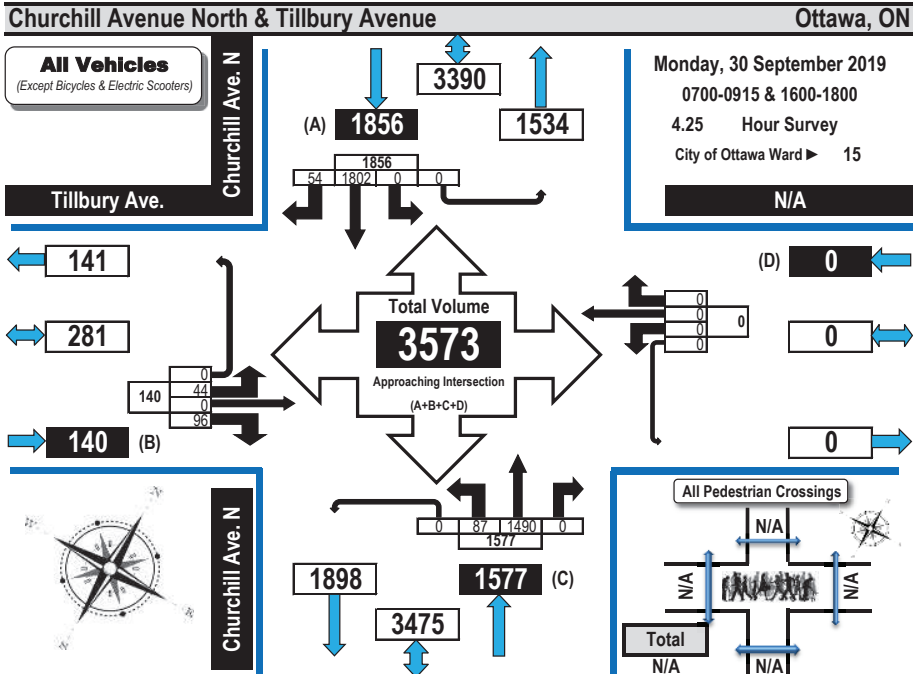

Turning Movement Count Summary, AM and PM Peak Hour Flow Diagrams

Automobiles, Taxis, Light Trucks, Vans, SUVs, Motorcycles, Heavy Trucks, Buses, and School Buses

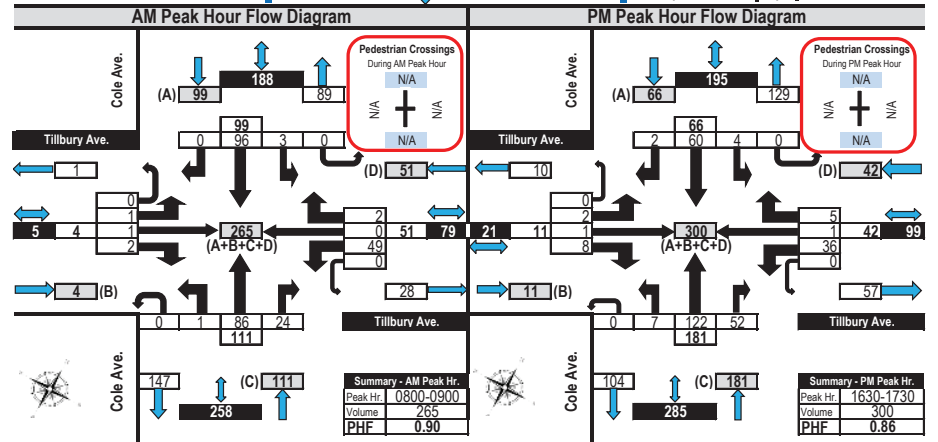
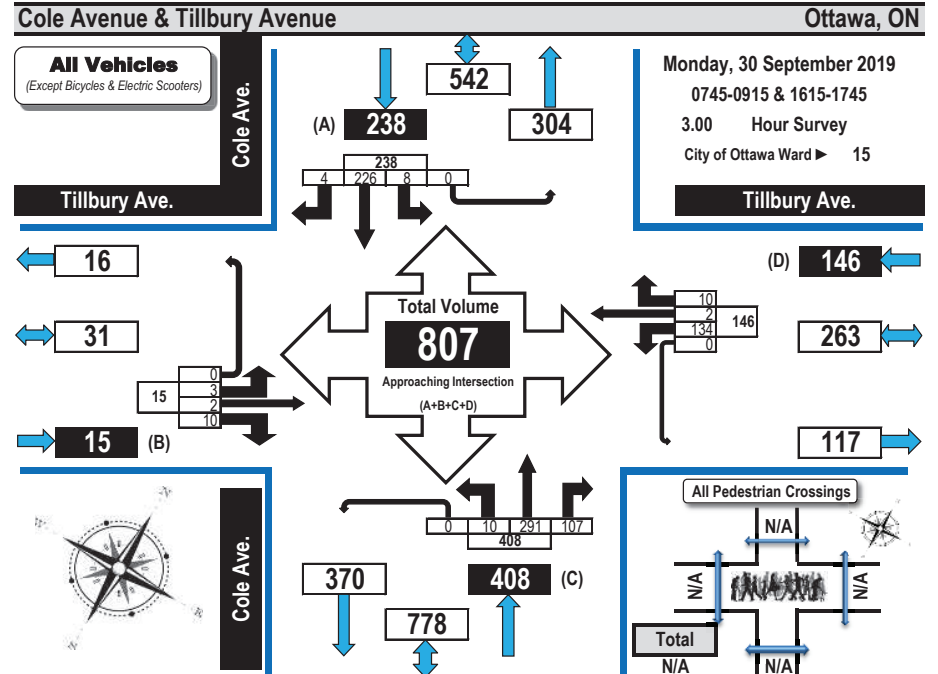

Appendix C

Synchro Intersection Worksheets – Existing Conditions

Lanes, Volumes, Timings
1: Cole & Carling

Existing
AM Peak Hour

Lane Group	EBL	EBT	EBR	WBL	WBT	WBR	NBL	NBT	NBR	SBL	SBT	SBR
Lane Configurations	↔	↔↔↔		↔	↔↔↔		↔	↔	↔	↔	↔	↔
Traffic Volume (vph)	86	651	127	212	465	21	119	73	114	19	43	46
Future Volume (vph)	86	651	127	212	465	21	119	73	114	19	43	46
Satd. Flow (prot)	1658	4539	0	1580	4639	0	1610	1745	1427	1658	1595	0
Fit Permitted	0.440			0.269			0.693			0.704		
Satd. Flow (perm)	758	4539	0	445	4639	0	1167	1745	1377	1202	1595	0
Satd. Flow (RTOR)		44			7				98			40
Lane Group Flow (vph)	96	864	0	236	540	0	132	81	127	21	99	0
Turn Type	pm+pt	NA		pm+pt	NA		Perm	NA	Perm	Perm	NA	
Protected Phases	5	2		1	6			8				4
Permitted Phases	2			6			8		8		4	
Detector Phase	5	2		1	6		8	8	8	4	4	
Switch Phase												
Minimum Initial (s)	5.0	10.0		5.0	10.0		10.0	10.0	10.0	10.0	10.0	
Minimum Split (s)	10.4	30.8		10.4	30.8		30.6	30.6	30.6	30.6	30.6	
Total Split (s)	23.0	60.0		23.0	60.0		31.0	31.0	31.0	31.0	31.0	
Total Split (%)	19.2%	50.0%		19.2%	50.0%		25.8%	25.8%	25.8%	25.8%	25.8%	
Yellow Time (s)	3.7	3.7		3.7	3.7		3.3	3.3	3.3	3.3	3.3	
All-Red Time (s)	1.7	2.1		1.7	2.1		3.3	3.3	3.3	3.3	3.3	
Lost Time Adjust (s)	0.0	0.0		0.0	0.0		0.0	0.0	0.0	0.0	0.0	
Total Lost Time (s)	5.4	5.8		5.4	5.8		6.6	6.6	6.6	6.6	6.6	
Lead/Lag	Lead	Lag		Lead	Lag		Lag	Lag	Lag	Lag	Lag	
Lead-Lag Optimize?	Yes	Yes		Yes	Yes		Yes	Yes	Yes	Yes	Yes	
Recall Mode	None	C-Max		None	C-Max		None	None	None	None	None	
Act Effct Green (s)	73.5	65.2		82.0	69.7		18.7	18.7	18.7	18.7	18.7	
Actuated g/C Ratio	0.61	0.54		0.68	0.58		0.16	0.16	0.16	0.16	0.16	
v/c Ratio	0.18	0.35		0.56	0.20		0.73	0.30	0.43	0.11	0.35	
Control Delay	8.4	16.3		26.8	10.9		69.9	45.9	17.4	42.0	29.6	
Queue Delay	0.0	0.0		0.0	0.0		0.0	0.0	0.0	0.0	0.0	
Total Delay	8.4	16.3		26.8	10.9		69.9	45.9	17.4	42.0	29.6	
LOS	A	B		C	B		E	D	B	D	C	
Approach Delay		15.5			15.8			44.6			31.7	
Approach LOS		B			B			D			C	
Queue Length 50th (m)	6.6	37.7		31.9	14.3		29.9	17.1	6.0	4.3	12.3	
Queue Length 95th (m)	14.2	57.3		58.7	25.3		49.0	30.2	22.6	11.1	27.0	
Internal Link Dist (m)		55.6			276.6			99.8			61.7	
Turn Bay Length (m)	24.0			120.0			98.0		5.0	20.0		
Base Capacity (vph)	649	2485		475	2695		237	354	358	244	356	
Starvation Cap Reductn	0	0		0	0		0	0	0	0	0	
Spillback Cap Reductn	0	0		0	0		0	0	0	0	0	
Storage Cap Reductn	0	0		0	0		0	0	0	0	0	
Reduced v/c Ratio	0.15	0.35		0.50	0.20		0.56	0.23	0.35	0.09	0.28	

Intersection Summary	
Cycle Length:	120
Actuated Cycle Length:	120
Offset:	84 (70%), Referenced to phase 2:EBTL and 6:WBTL, Start of Green
Natural Cycle:	80
Control Type:	Actuated-Coordinated

Lanes, Volumes, Timings
1: Cole & Carling

Existing
AM Peak Hour

Lane Group	Ø3	Ø7
Lane Configurations		
Traffic Volume (vph)		
Future Volume (vph)		
Satd. Flow (prot)		
Fit Permitted		
Satd. Flow (perm)		
Satd. Flow (RTOR)		
Lane Group Flow (vph)		
Turn Type		
Protected Phases	3	7
Permitted Phases		
Detector Phase		
Switch Phase		
Minimum Initial (s)	1.0	1.0
Minimum Split (s)	3.0	3.0
Total Split (s)	6.0	6.0
Total Split (%)	5%	5%
Yellow Time (s)	2.0	2.0
All-Red Time (s)	0.0	0.0
Lost Time Adjust (s)		
Total Lost Time (s)		
Lead/Lag	Lead	Lead
Lead-Lag Optimize?	Yes	Yes
Recall Mode	Max	Max
Act Effct Green (s)		
Actuated g/C Ratio		
v/c Ratio		
Control Delay		
Queue Delay		
Total Delay		
LOS		
Approach Delay		
Approach LOS		
Queue Length 50th (m)		
Queue Length 95th (m)		
Internal Link Dist (m)		
Turn Bay Length (m)		
Base Capacity (vph)		
Starvation Cap Reductn		
Spillback Cap Reductn		
Storage Cap Reductn		
Reduced v/c Ratio		

Intersection Summary	
Cycle Length:	120
Actuated Cycle Length:	120
Offset:	84 (70%), Referenced to phase 2:EBTL and 6:WBTL, Start of Green
Natural Cycle:	80
Control Type:	Actuated-Coordinated

Lanes, Volumes, Timings
1: Cole & Carling

Existing
AM Peak Hour

Maximum v/c Ratio: 0.73	Intersection LOS: C
Intersection Signal Delay: 21.0	ICU Level of Service C
Intersection Capacity Utilization 64.3%	
Analysis Period (min) 15	

Splits and Phases: 1: Cole & Carling

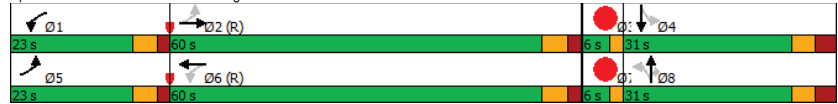

Lanes, Volumes, Timings
2: Churchill & Carling

Existing
AM Peak Hour

Lane Group	EBL	EBT	EBR	WBL	WBT	WBR	NBL	NBT	NBR	SBL	SBT	SBR
Lane Configurations	↔	↔↔↔	↔	↔	↔↔↔	↔	↔	↔	↔	↔	↔	↔
Traffic Volume (vph)	173	1352	98	106	610	154	11	5	11	336	31	243
Future Volume (vph)	173	1352	98	106	610	154	11	5	11	336	31	243
Satd. Flow (prot)	1595	4701	0	1658	4440	0	1551	1392	0	1642	1413	0
Fit Permitted	0.950			0.950			0.575			0.413		
Satd. Flow (perm)	1578	4701	0	1653	4440	0	926	1392	0	700	1413	0
Satd. Flow (RTOR)		11			58			12			270	
Lane Group Flow (vph)	192	1611	0	118	849	0	12	18	0	373	304	0
Turn Type	Prot	NA		Prot	NA		Perm	NA		Perm	NA	
Protected Phases	5	2		1	6			8			4	
Permitted Phases							8				4	
Detector Phase	5	2		1	6		8	8			4	4
Switch Phase												
Minimum Initial (s)	5.0	10.0		5.0	10.0		10.0	10.0		10.0	10.0	
Minimum Split (s)	11.1	34.1		11.1	34.1		40.0	40.0		40.0	40.0	
Total Split (s)	25.0	50.0		25.0	50.0		40.0	40.0		40.0	40.0	
Total Split (%)	20.8%	41.7%		20.8%	41.7%		33.3%	33.3%		33.3%	33.3%	
Yellow Time (s)	3.7	3.7		3.7	3.7		3.3	3.3		3.3	3.3	
All-Red Time (s)	2.4	2.4		2.4	2.4		3.5	3.5		3.5	3.5	
Lost Time Adjust (s)	0.0	0.0		0.0	0.0		0.0	0.0		0.0	0.0	
Total Lost Time (s)	6.1	6.1		6.1	6.1		6.8	6.8		6.8	6.8	
Lead/Lag	Lead	Lag		Lead	Lag		Lag	Lag		Lag	Lag	
Lead-Lag Optimize?	Yes	Yes		Yes	Yes		Yes	Yes		Yes	Yes	
Recall Mode	None	C-Max		None	C-Max		None	None		None	None	
Act Effct Green (s)	17.4	49.1		13.7	45.4		23.9	23.9		33.2	33.2	
Actuated g/C Ratio	0.14	0.41		0.11	0.38		0.20	0.20		0.28	0.28	
v/c Ratio	0.83	0.84		0.62	0.50		0.07	0.06		1.93	0.52	
Control Delay	85.7	31.8		64.3	27.9		33.5	19.2		464.8	9.6	
Queue Delay	0.0	0.0		0.0	0.0		0.0	0.0		0.0	0.0	
Total Delay	85.7	31.8		64.3	27.9		33.5	19.2		464.8	9.6	
LOS	F	C		E	C		C	B		F	A	
Approach Delay		37.5			32.4			25.0			260.4	
Approach LOS		D			C			C			F	
Queue Length 50th (m)	42.1	123.4		26.9	52.6		2.1	1.0		~135.3	6.0	
Queue Length 95th (m)	#79.3	#163.8		44.1	65.6		7.0	6.7		#193.6	30.2	
Internal Link Dist (m)		276.6			94.1			108.6			70.1	
Turn Bay Length (m)	66.5			65.0						19.5		
Base Capacity (vph)	251	1928		261	1714		256	393		193	586	
Starvation Cap Reductn	0	0		0	0		0	0		0	0	
Spillback Cap Reductn	0	0		0	0		0	0		0	0	
Storage Cap Reductn	0	0		0	0		0	0		0	0	
Reduced v/c Ratio	0.76	0.84		0.45	0.50		0.05	0.05		1.93	0.52	

Intersection Summary

Cycle Length: 120
Actuated Cycle Length: 120
Offset: 101 (84%), Referenced to phase 2:EBT and 6:WBT, Start of Green
Natural Cycle: 95
Control Type: Actuated-Coordinated

Lanes, Volumes, Timings
2: Churchill & Carling

Existing
AM Peak Hour

Lane Group	Ø3	Ø7
Lane Configurations		
Traffic Volume (vph)		
Future Volume (vph)		
Satd. Flow (prot)		
Fit Permitted		
Satd. Flow (perm)		
Satd. Flow (RTOR)		
Lane Group Flow (vph)		
Turn Type		
Protected Phases	3	7
Permitted Phases		
Detector Phase		
Switch Phase		
Minimum Initial (s)	1.0	1.0
Minimum Split (s)	5.0	5.0
Total Split (s)	5.0	5.0
Total Split (%)	4%	4%
Yellow Time (s)	2.0	2.0
All-Red Time (s)	0.0	0.0
Lost Time Adjust (s)		
Total Lost Time (s)		
Lead/Lag	Lead	Lead
Lead-Lag Optimize?	Yes	Yes
Recall Mode	Max	Max
Act Effct Green (s)		
Actuated g/C Ratio		
v/c Ratio		
Control Delay		
Queue Delay		
Total Delay		
LOS		
Approach Delay		
Approach LOS		
Queue Length 50th (m)		
Queue Length 95th (m)		
Internal Link Dist (m)		
Turn Bay Length (m)		
Base Capacity (vph)		
Starvation Cap Reductn		
Spillback Cap Reductn		
Storage Cap Reductn		
Reduced v/c Ratio		
Intersection Summary		

Lanes, Volumes, Timings
2: Churchill & Carling

Existing
AM Peak Hour

Maximum v/c Ratio: 1.93	Intersection LOS: E
Intersection Signal Delay: 79.4	ICU Level of Service D
Intersection Capacity Utilization 79.0%	
Analysis Period (min) 15	
~ Volume exceeds capacity, queue is theoretically infinite. Queue shown is maximum after two cycles.	
# 95th percentile volume exceeds capacity, queue may be longer. Queue shown is maximum after two cycles.	

Splits and Phases: 2: Churchill & Carling

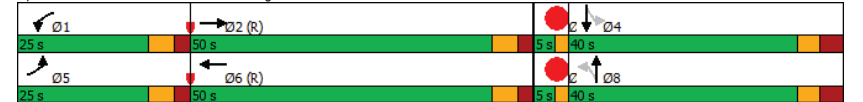

HCM 2010 TWSC
3: Cole & Tillbury

Existing
AM Peak Hour

Intersection												
Int Delay, s/veh	2.2											
Movement	EBL	EBT	EBR	WBL	WBT	WBR	NBL	NBT	NBR	SBL	SBT	SBR
Lane Configurations	↔			↔			↔			↔		
Traffic Vol, veh/h	1	1	2	49	0	2	1	86	24	3	96	0
Future Vol, veh/h	1	1	2	49	0	2	1	86	24	3	96	0
Conflicting Peds, #/hr	0	0	0	0	0	0	0	0	0	0	0	0
Sign Control	Stop	Stop	Stop	Stop	Stop	Stop	Free	Free	Free	Free	Free	Free
RT Channelized	-	-	None	-	-	None	-	-	None	-	-	None
Storage Length	-	-	-	-	-	-	-	-	-	-	-	-
Veh in Median Storage, #	-	0	-	-	0	-	-	0	-	-	0	-
Grade, %	-	0	-	-	0	-	-	0	-	-	0	-
Peak Hour Factor	90	90	90	90	90	90	90	90	90	90	90	90
Heavy Vehicles, %	2	2	2	2	2	2	2	2	2	2	2	2
Mvmt Flow	1	1	2	54	0	2	1	96	27	3	107	0

Major/Minor	Minor2	Minor1	Major1	Major2										
Conflicting Flow All	226	238	107	227	225	110	107	0	0	123	0	0		
Stage 1	113	113	-	112	112	-	-	-	-	-	-	-		
Stage 2	113	125	-	115	113	-	-	-	-	-	-	-		
Critical Hdwy	7.12	6.52	6.22	7.12	6.52	6.22	4.12	-	-	4.12	-	-		
Critical Hdwy Stg 1	6.12	5.52	-	6.12	5.52	-	-	-	-	-	-	-		
Critical Hdwy Stg 2	6.12	5.52	-	6.12	5.52	-	-	-	-	-	-	-		
Follow-up Hdwy	3.518	4.018	3.318	3.518	4.018	3.318	2.218	-	-	2.218	-	-		
Pot Cap-1 Maneuver	729	663	947	728	674	943	1484	-	-	1464	-	-		
Stage 1	892	802	-	893	803	-	-	-	-	-	-	-		
Stage 2	892	792	-	890	802	-	-	-	-	-	-	-		
Platoon blocked, %	-	-	-	-	-	-	-	-	-	-	-	-		
Mov Cap-1 Maneuver	725	661	947	724	672	943	1484	-	-	1464	-	-		
Mov Cap-2 Maneuver	725	661	-	724	672	-	-	-	-	-	-	-		
Stage 1	891	800	-	892	802	-	-	-	-	-	-	-		
Stage 2	889	791	-	885	800	-	-	-	-	-	-	-		

Approach	EB	WB	NB	SB
HCM Control Delay, s	9.5	10.3	0.1	0.2
HCM LOS	A	B		

Minor Lane/Major Mvmt	NBL	NBT	NBR	EBLn1	WBLn1	SBL	SBT	SBR
Capacity (veh/h)	1484	-	-	799	731	1464	-	-
HCM Lane V/C Ratio	0.001	-	-	0.006	0.078	0.002	-	-
HCM Control Delay (s)	7.4	0	-	9.5	10.3	7.5	0	-
HCM Lane LOS	A	A	-	A	B	A	A	-
HCM 95th %tile Q(veh)	0	-	-	0	0.3	0	-	-

HCM 2010 TWSC
4: Churchill & Tillbury

Existing
AM Peak Hour

Intersection						
Int Delay, s/veh	0.6					
Movement	EBL	EBR	NBL	NBT	SBT	SBR
Lane Configurations	↔			↔		
Traffic Vol, veh/h	4	26	14	315	473	16
Future Vol, veh/h	4	26	14	315	473	16
Conflicting Peds, #/hr	0	0	0	0	0	0
Sign Control	Stop	Stop	Free	Free	Free	Free
RT Channelized	-	None	-	None	-	None
Storage Length	0	-	-	-	-	-
Veh in Median Storage, #	0	-	-	0	0	-
Grade, %	0	-	-	0	0	-
Peak Hour Factor	90	90	90	90	90	90
Heavy Vehicles, %	2	2	2	2	2	2
Mvmt Flow	4	29	16	350	526	18

Major/Minor	Minor2	Major1	Major2			
Conflicting Flow All	917	535	544	0	-	0
Stage 1	535	-	-	-	-	-
Stage 2	382	-	-	-	-	-
Critical Hdwy	6.42	6.22	4.12	-	-	-
Critical Hdwy Stg 1	5.42	-	-	-	-	-
Critical Hdwy Stg 2	5.42	-	-	-	-	-
Follow-up Hdwy	3.518	3.318	2.218	-	-	-
Pot Cap-1 Maneuver	302	545	1025	-	-	-
Stage 1	587	-	-	-	-	-
Stage 2	690	-	-	-	-	-
Platoon blocked, %	-	-	-	-	-	-
Mov Cap-1 Maneuver	296	545	1025	-	-	-
Mov Cap-2 Maneuver	296	-	-	-	-	-
Stage 1	576	-	-	-	-	-
Stage 2	690	-	-	-	-	-

Approach	EB	NB	SB
HCM Control Delay, s	12.9	0.4	0
HCM LOS	B		

Minor Lane/Major Mvmt	NBL	NBT	EBLn1	SBT	SBR
Capacity (veh/h)	1025	-	490	-	-
HCM Lane V/C Ratio	0.015	-	0.068	-	-
HCM Control Delay (s)	8.6	0	12.9	-	-
HCM Lane LOS	A	A	B	-	-
HCM 95th %tile Q(veh)	0	-	0.2	-	-

Lanes, Volumes, Timings
1: Cole & Carling

Existing
PM Peak Hour

Lane Group	EBL	EBT	EBR	WBL	WBT	WBR	NBL	NBT	NBR	SBL	SBT	SBR
Lane Configurations	↔	↔↔↔		↔	↔↔↔		↔	↔	↔	↔	↔	
Traffic Volume (vph)	89	613	131	221	700	41	139	59	141	24	45	73
Future Volume (vph)	89	613	131	221	700	41	139	59	141	24	45	73
Satd. Flow (prot)	1658	4592	0	1642	4713	0	1658	1745	1469	1658	1556	0
Fit Permitted	0.327			0.283			0.603			0.714		
Satd. Flow (perm)	567	4592	0	484	4713	0	1039	1745	1415	1218	1556	0
Satd. Flow (RTOR)		44			9				128			53
Lane Group Flow (vph)	99	827	0	246	824	0	154	66	157	27	131	0
Turn Type	pm+pt	NA		pm+pt	NA		Perm	NA	Perm	Perm	NA	
Protected Phases	5	2		1	6			8				4
Permitted Phases	2			6			8		8		4	
Detector Phase	5	2		1	6		8	8	8	4	4	
Switch Phase												
Minimum Initial (s)	5.0	10.0		5.0	10.0		10.0	10.0	10.0	10.0	10.0	
Minimum Split (s)	10.4	30.8		10.4	30.8		30.6	30.6	30.6	30.6	30.6	
Total Split (s)	28.0	70.0		28.0	70.0		36.0	36.0	36.0	36.0	36.0	
Total Split (%)	20.0%	50.0%		20.0%	50.0%		25.7%	25.7%	25.7%	25.7%	25.7%	
Yellow Time (s)	3.7	3.7		3.7	3.7		3.3	3.3	3.3	3.3	3.3	
All-Red Time (s)	1.7	2.1		1.7	2.1		3.3	3.3	3.3	3.3	3.3	
Lost Time Adjust (s)	0.0	0.0		0.0	0.0		0.0	0.0	0.0	0.0	0.0	
Total Lost Time (s)	5.4	5.8		5.4	5.8		6.6	6.6	6.6	6.6	6.6	
Lead/Lag	Lead	Lag		Lead	Lag		Lag	Lag	Lag	Lag	Lag	
Lead-Lag Optimize?	Yes	Yes		Yes	Yes		Yes	Yes	Yes	Yes	Yes	
Recall Mode	None	C-Max		None	C-Max		None	None	None	None	None	
Act Effct Green (s)	87.5	78.8		96.9	83.8		24.1	24.1	24.1	24.1	24.1	
Actuated g/C Ratio	0.62	0.56		0.69	0.60		0.17	0.17	0.17	0.17	0.17	
v/c Ratio	0.24	0.32		0.55	0.29		0.86	0.22	0.45	0.13	0.42	
Control Delay	9.6	16.8		13.2	14.7		94.2	49.7	16.2	47.8	33.2	
Queue Delay	0.0	0.0		0.0	0.0		0.0	0.0	0.0	0.0	0.0	
Total Delay	9.6	16.8		13.2	14.7		94.2	49.7	16.2	47.8	33.2	
LOS	A	B		B	B		F	D	B	D	C	
Approach Delay		16.1			14.3			53.9			35.7	
Approach LOS		B			B			D			D	
Queue Length 50th (m)	8.3	41.3		22.9	39.2		41.5	15.7	6.8	6.3	18.8	
Queue Length 95th (m)	15.9	58.3		37.4	53.2		#70.6	28.7	26.7	14.7	37.3	
Internal Link Dist (m)		55.6			276.6			99.8			61.7	
Turn Bay Length (m)	24.0			120.0			98.0		5.0	20.0		
Base Capacity (vph)	571	2603		525	2823		218	366	398	255	368	
Starvation Cap Reductn	0	0		0	0		0	0	0	0	0	
Spillback Cap Reductn	0	0		0	0		0	0	0	0	0	
Storage Cap Reductn	0	0		0	0		0	0	0	0	0	
Reduced v/c Ratio	0.17	0.32		0.47	0.29		0.71	0.18	0.39	0.11	0.36	

Intersection Summary

Cycle Length: 140
 Actuated Cycle Length: 140
 Offset: 93 (66%), Referenced to phase 2:EBTL and 6:WBTL, Start of Green
 Natural Cycle: 75
 Control Type: Actuated-Coordinated

Lanes, Volumes, Timings
1: Cole & Carling

Existing
PM Peak Hour

Lane Group	Ø3	Ø7
Lane Configurations		
Traffic Volume (vph)		
Future Volume (vph)		
Satd. Flow (prot)		
Fit Permitted		
Satd. Flow (perm)		
Satd. Flow (RTOR)		
Lane Group Flow (vph)		
Turn Type		
Protected Phases	3	7
Permitted Phases		
Detector Phase		
Switch Phase		
Minimum Initial (s)	1.0	1.0
Minimum Split (s)	3.0	3.0
Total Split (s)	6.0	6.0
Total Split (%)	4%	4%
Yellow Time (s)	2.0	2.0
All-Red Time (s)	0.0	0.0
Lost Time Adjust (s)		
Total Lost Time (s)		
Lead/Lag	Lead	Lead
Lead-Lag Optimize?	Yes	Yes
Recall Mode	Max	Max
Act Effct Green (s)		
Actuated g/C Ratio		
v/c Ratio		
Control Delay		
Queue Delay		
Total Delay		
LOS		
Approach Delay		
Approach LOS		
Queue Length 50th (m)		
Queue Length 95th (m)		
Internal Link Dist (m)		
Turn Bay Length (m)		
Base Capacity (vph)		
Starvation Cap Reductn		
Spillback Cap Reductn		
Storage Cap Reductn		
Reduced v/c Ratio		

Intersection Summary

Lanes, Volumes, Timings
1: Cole & Carling

Existing
PM Peak Hour

Maximum v/c Ratio: 0.86	Intersection LOS: C
Intersection Signal Delay: 22.2	ICU Level of Service C
Intersection Capacity Utilization 65.3%	
Analysis Period (min) 15	
# 95th percentile volume exceeds capacity, queue may be longer.	
Queue shown is maximum after two cycles.	

Splits and Phases: 1: Cole & Carling

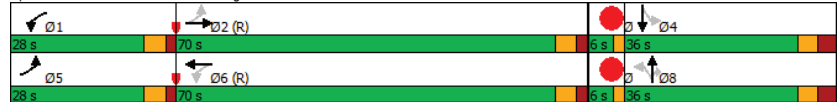

Lanes, Volumes, Timings
2: Churchill & Carling

Existing
PM Peak Hour

Lane Group	EBL	EBT	EBR	WBL	WBT	WBR	NBL	NBT	NBR	SBL	SBT	SBR
Lane Configurations	↖ ↗		↘	↖ ↗		↘	↖ ↗		↘	↖ ↗		↘
Traffic Volume (vph)	245	792	18	37	1782	218	96	33	26	182	7	269
Future Volume (vph)	245	792	18	37	1782	218	96	33	26	182	7	269
Satd. Flow (prot)	1642	4699	0	1658	4663	0	1658	1604	0	1626	1399	0
Fit Permitted	0.950		0.950		0.292		0.714					
Satd. Flow (perm)	1639	4699	0	1640	4663	0	502	1604	0	1210	1399	0
Satd. Flow (RTOR)	3		20		29		299					
Lane Group Flow (vph)	272	900	0	41	2222	0	107	66	0	202	307	0
Turn Type	Prot		NA		Prot		NA		Perm		NA	
Protected Phases	5	2		1	6		8		8	4	4	
Permitted Phases					8		4					
Detector Phase	5	2		1	6		8	8		4	4	
Switch Phase												
Minimum Initial (s)	5.0	10.0		5.0	10.0		10.0	10.0		10.0	10.0	
Minimum Split (s)	11.1	34.1		11.1	34.1		40.0	40.0		40.0	40.0	
Total Split (s)	25.0	50.0		25.0	50.0		40.0	40.0		40.0	40.0	
Total Split (%)	20.8%	41.7%		20.8%	41.7%		33.3%	33.3%		33.3%	33.3%	
Yellow Time (s)	3.7	3.7		3.7	3.7		3.3	3.3		3.3	3.3	
All-Red Time (s)	2.4	2.4		2.4	2.4		3.5	3.5		3.5	3.5	
Lost Time Adjust (s)	0.0	0.0		0.0	0.0		0.0	0.0		0.0	0.0	
Total Lost Time (s)	6.1	6.1		6.1	6.1		6.8	6.8		6.8	6.8	
Lead/Lag	Lead	Lag		Lead	Lag		Lag	Lag		Lag	Lag	
Lead-Lag Optimize?	Yes	Yes		Yes	Yes		Yes	Yes		Yes	Yes	
Recall Mode	None	C-Max		None	C-Max		None	None		None	None	
Act Effct Green (s)	24.5	64.2		8.4	45.8		25.7	25.7		25.7	25.7	
Actuated g/C Ratio	0.20	0.54		0.07	0.38		0.21	0.21		0.21	0.21	
v/c Ratio	0.81	0.36		0.35	1.24		1.00	0.18		0.78	0.57	
Control Delay	66.3	18.6		60.8	145.8		134.0	22.6		64.1	9.0	
Queue Delay	0.0	0.0		0.0	0.0		0.0	0.0		0.0	0.0	
Total Delay	66.3	18.6		60.8	145.8		134.0	22.6		64.1	9.0	
LOS	E	B		E	F		F	C		E	A	
Approach Delay	29.7		144.3		91.5		30.8					
Approach LOS	C		F		F		C					
Queue Length 50th (m)	60.0	44.3		9.4	~244.9		~25.8	7.1		45.4	1.5	
Queue Length 95th (m)	#122.4	65.6		20.4	#274.1		#54.2	17.4		67.2	23.9	
Internal Link Dist (m)	276.6		94.1		108.6		70.1					
Turn Bay Length (m)	66.5			65.0				19.5				
Base Capacity (vph)	335	2516		261	1793		138	464		334	603	
Starvation Cap Reductn	0	0		0	0		0	0		0	0	
Spillback Cap Reductn	0	0		0	0		0	0		0	0	
Storage Cap Reductn	0	0		0	0		0	0		0	0	
Reduced v/c Ratio	0.81	0.36		0.16	1.24		0.78	0.14		0.60	0.51	

Intersection Summary

Cycle Length: 120
Actuated Cycle Length: 120
Offset: 92 (77%), Referenced to phase 2:EBT and 6:WBT, Start of Green
Natural Cycle: 145
Control Type: Actuated-Coordinated

Lanes, Volumes, Timings
2: Churchill & Carling

Existing
PM Peak Hour

Lane Group	Ø3	Ø7
Lane Configurations		
Traffic Volume (vph)		
Future Volume (vph)		
Satd. Flow (prot)		
Fit Permitted		
Satd. Flow (perm)		
Satd. Flow (RTOR)		
Lane Group Flow (vph)		
Turn Type		
Protected Phases	3	7
Permitted Phases		
Detector Phase		
Switch Phase		
Minimum Initial (s)	1.0	1.0
Minimum Split (s)	5.0	5.0
Total Split (s)	5.0	5.0
Total Split (%)	4%	4%
Yellow Time (s)	2.0	2.0
All-Red Time (s)	0.0	0.0
Lost Time Adjust (s)		
Total Lost Time (s)		
Lead/Lag	Lead	Lead
Lead-Lag Optimize?	Yes	Yes
Recall Mode	Max	Max
Act Effct Green (s)		
Actuated g/C Ratio		
v/c Ratio		
Control Delay		
Queue Delay		
Total Delay		
LOS		
Approach Delay		
Approach LOS		
Queue Length 50th (m)		
Queue Length 95th (m)		
Internal Link Dist (m)		
Turn Bay Length (m)		
Base Capacity (vph)		
Starvation Cap Reductn		
Spillback Cap Reductn		
Storage Cap Reductn		
Reduced v/c Ratio		
Intersection Summary		

Lanes, Volumes, Timings
2: Churchill & Carling

Existing
PM Peak Hour

Maximum v/c Ratio: 1.24	Intersection LOS: F
Intersection Signal Delay: 95.4	ICU Level of Service H
Intersection Capacity Utilization 110.0%	
Analysis Period (min) 15	
~ Volume exceeds capacity, queue is theoretically infinite. Queue shown is maximum after two cycles.	
# 95th percentile volume exceeds capacity, queue may be longer. Queue shown is maximum after two cycles.	

Splits and Phases: 2: Churchill & Carling



HCM 2010 TWSC
3: Cole & Tillbury

Existing
PM Peak Hour

Intersection												
Int Delay, s/veh	2.1											
Movement	EBL	EBT	EBR	WBL	WBT	WBR	NBL	NBT	NBR	SBL	SBT	SBR
Lane Configurations	↕			↕			↕			↕		
Traffic Vol, veh/h	2	1	8	36	1	5	7	122	52	4	60	2
Future Vol, veh/h	2	1	8	36	1	5	7	122	52	4	60	2
Conflicting Peds, #/hr	0	0	0	0	0	0	0	0	0	0	0	0
Sign Control	Stop	Stop	Stop	Stop	Stop	Stop	Free	Free	Free	Free	Free	Free
RT Channelized	-	-	None	-	-	None	-	-	None	-	-	None
Storage Length	-	-	-	-	-	-	-	-	-	-	-	-
Veh in Median Storage, #	-	0	-	-	0	-	-	0	-	-	0	-
Grade, %	-	0	-	-	0	-	-	0	-	-	0	-
Peak Hour Factor	90	90	90	90	90	90	90	90	90	90	90	90
Heavy Vehicles, %	2	2	2	2	2	2	2	2	2	2	2	2
Mvmt Flow	2	1	9	40	1	6	8	136	58	4	67	2

Major/Minor	Minor2	Minor1	Major1	Major2
Conflicting Flow All	261	286	68	262
Stage 1	76	76	-	181
Stage 2	185	210	-	81
Critical Hdwy	7.12	6.52	6.22	7.12
Critical Hdwy Stg 1	6.12	5.52	-	6.12
Critical Hdwy Stg 2	6.12	5.52	-	6.12
Follow-up Hdwy	3.518	4.018	3.318	3.518
Pot Cap-1 Maneuver	692	623	995	691
Stage 1	933	832	-	821
Stage 2	817	728	-	927
Platoon blocked, %	-	-	-	-
Mov Cap-1 Maneuver	682	617	995	679
Mov Cap-2 Maneuver	682	617	-	679
Stage 1	927	830	-	816
Stage 2	806	724	-	915

Approach	EB	WB	NB	SB
HCM Control Delay, s	9.2	10.5	0.3	0.5
HCM LOS	A	B		

Minor Lane/Major Mvmt	NBL	NBT	NBR	EBLn1	WBLn1	SBL	SBT	SBR
Capacity (veh/h)	1532	-	-	873	697	1379	-	-
HCM Lane V/C Ratio	0.005	-	-	0.014	0.067	0.003	-	-
HCM Control Delay (s)	7.4	0	-	9.2	10.5	7.6	0	-
HCM Lane LOS	A	A	-	A	B	A	A	-
HCM 95th %tile Q(veh)	0	-	-	0	0.2	0	-	-

HCM 2010 TWSC
4: Churchill & Tillbury

Existing
PM Peak Hour

Intersection						
Int Delay, s/veh	0.8					
Movement	EBL	EBR	NBL	NBT	SBT	SBR
Lane Configurations	↕		↕		↕	
Traffic Vol, veh/h	9	25	31	464	454	17
Future Vol, veh/h	9	25	31	464	454	17
Conflicting Peds, #/hr	0	0	0	0	0	0
Sign Control	Stop	Stop	Free	Free	Free	Free
RT Channelized	-	None	-	None	-	None
Storage Length	0	-	-	-	-	-
Veh in Median Storage, #	0	-	-	0	0	-
Grade, %	0	-	-	0	0	-
Peak Hour Factor	90	90	90	90	90	90
Heavy Vehicles, %	2	2	2	2	2	2
Mvmt Flow	10	28	34	516	504	19

Major/Minor	Minor2	Major1	Major2
Conflicting Flow All	1098	514	523
Stage 1	514	-	-
Stage 2	584	-	-
Critical Hdwy	6.42	6.22	4.12
Critical Hdwy Stg 1	5.42	-	-
Critical Hdwy Stg 2	5.42	-	-
Follow-up Hdwy	3.518	3.318	2.218
Pot Cap-1 Maneuver	235	560	1043
Stage 1	600	-	-
Stage 2	557	-	-
Platoon blocked, %	-	-	-
Mov Cap-1 Maneuver	224	560	1043
Mov Cap-2 Maneuver	224	-	-
Stage 1	572	-	-
Stage 2	557	-	-

Approach	EB	NB	SB
HCM Control Delay, s	14.9	0.5	0
HCM LOS	B		

Minor Lane/Major Mvmt	NBL	NBT	EBLn1	SBT	SBR
Capacity (veh/h)	1043	-	401	-	-
HCM Lane V/C Ratio	0.033	-	0.094	-	-
HCM Control Delay (s)	8.6	0	14.9	-	-
HCM Lane LOS	A	A	B	-	-
HCM 95th %tile Q(veh)	0.1	-	0.3	-	-

Appendix D

Collision Data

Accident Date	Accident Year	Accident Time	Location	Environment Condition	Light	Traffic Control	Traffic Control Condition	Classification Of Accident	Initial Impact Type	Road Surface Condition	# Vehicles	# Motorcycles	# Bicycles	# Pedestrians
10/8/2016	2016	15:20	CARLING AVE @ CLYDE AVE/COLE AVE (0006984)	01 - Clear	01 - Daylight	01 - Traffic signal	01 - Functioning	03 - P.D. only	01 - SMV other	01 - Dry	1	0	0	0
11/28/2016	2016	8:41	CARLING AVE @ CLYDE AVE/COLE AVE (0006984)	01 - Clear	01 - Daylight	01 - Traffic signal	01 - Functioning	02 - Non-fatal injury	07 - SMV other	01 - Dry	2	0	0	1
2/12/2016	2016	9:41	CARLING AVE @ CLYDE AVE/COLE AVE (0006984)	01 - Clear	01 - Daylight	01 - Traffic signal	01 - Functioning	02 - Non-fatal injury	02 - Wet	02 - Wet	2	0	0	0
8/2/2016	2016	10:00	CARLING AVE @ CLYDE AVE/COLE AVE (0006984)	01 - Clear	01 - Daylight	01 - Traffic signal	01 - Functioning	02 - Non-fatal injury	05 - Turning movement	01 - Dry	2	0	0	0
10/14/2017	2017	13:15	CARLING AVE @ CLYDE AVE/COLE AVE (0006984)	01 - Clear	01 - Daylight	01 - Traffic signal	00 - Unknown	03 - P.D. only	05 - Turning movement	01 - Dry	2	0	0	0
10/26/2017	2017	16:59	CARLING AVE @ CLYDE AVE/COLE AVE (0006984)	01 - Clear	01 - Daylight	01 - Traffic signal	01 - Functioning	03 - P.D. only	05 - Turning movement	01 - Dry	3	0	0	0
11/30/2017	2017	14:31	CARLING AVE @ CLYDE AVE/COLE AVE (0006984)	01 - Clear	01 - Daylight	01 - Traffic signal	01 - Functioning	03 - P.D. only	03 - Rear end	02 - Wet	2	0	0	0
5/18/2017	2017	8:36	CARLING AVE @ CLYDE AVE/COLE AVE (0006984)	01 - Clear	01 - Daylight	01 - Traffic signal	01 - Functioning	02 - Non-fatal injury	01 - Traffic signal	01 - Dry	2	0	0	0
6/28/2017	2017	17:55	CARLING AVE @ CLYDE AVE/COLE AVE (0006984)	01 - Clear	01 - Daylight	01 - Traffic signal	01 - Functioning	03 - P.D. only	04 - Sideswipe	01 - Dry	2	0	0	0
6/27/2017	2017	14:30	CARLING AVE @ CLYDE AVE/COLE AVE (0006984)	01 - Clear	01 - Daylight	01 - Traffic signal	01 - Functioning	03 - P.D. only	05 - Turning movement	01 - Dry	2	0	0	0
7/7/2017	2017	15:43	CARLING AVE @ CLYDE AVE/COLE AVE (0006984)	01 - Clear	01 - Daylight	01 - Traffic signal	01 - Functioning	03 - P.D. only	02 - Rear end	01 - Dry	2	0	0	0
7/26/2017	2017	8:34	CARLING AVE @ CLYDE AVE/COLE AVE (0006984)	01 - Clear	01 - Daylight	01 - Traffic signal	01 - Functioning	02 - Non-fatal injury	05 - Turning movement	01 - Dry	2	0	0	0
7/20/2017	2017	15:48	CARLING AVE @ CLYDE AVE/COLE AVE (0006984)	01 - Clear	01 - Daylight	01 - Traffic signal	01 - Functioning	02 - Non-fatal injury	02 - Angle	01 - Dry	2	0	0	0
9/21/2017	2017	16:00	CARLING AVE @ CLYDE AVE/COLE AVE (0006984)	01 - Clear	01 - Daylight	01 - Traffic signal	01 - Functioning	02 - Non-fatal injury	03 - Rear end	01 - Dry	2	0	0	0
9/22/2017	2017	15:43	CARLING AVE @ CLYDE AVE/COLE AVE (0006984)	01 - Clear	01 - Daylight	01 - Traffic signal	00 - Unknown	03 - P.D. only	04 - Sideswipe	01 - Dry	2	0	0	0
10/19/2018	2018	9:19	CARLING AVE @ CLYDE AVE/COLE AVE (0006984)	01 - Clear	01 - Daylight	01 - Traffic signal	01 - Functioning	03 - P.D. only	05 - Turning movement	01 - Dry	2	0	0	0
10/27/2018	2018	22:36	CARLING AVE @ CLYDE AVE/COLE AVE (0006984)	03 - Snow	07 - Dark	01 - Traffic signal	01 - Functioning	03 - P.D. only	04 - Sideswipe	02 - Wet	2	0	0	0
10/24/2018	2018	12:43	CARLING AVE @ CLYDE AVE/COLE AVE (0006984)	01 - Clear	01 - Daylight	01 - Traffic signal	01 - Functioning	03 - P.D. only	05 - Turning movement	01 - Dry	2	0	0	0
11/16/2018	2018	7:23	CARLING AVE @ CLYDE AVE/COLE AVE (0006984)	03 - Snow	01 - Daylight	01 - Traffic signal	01 - Functioning	02 - Non-fatal injury	02 - Angle	03 - Loose snow	3	0	0	0
11/23/2018	2018	13:08	CARLING AVE @ CLYDE AVE/COLE AVE (0006984)	01 - Clear	01 - Daylight	01 - Traffic signal	01 - Functioning	02 - Non-fatal injury	07 - SMV other	01 - Dry	1	0	0	1
2/1/2018	2018	7:07	CARLING AVE @ CLYDE AVE/COLE AVE (0006984)	03 - Snow	03 - Dawn	01 - Traffic signal	01 - Functioning	03 - P.D. only	04 - Sideswipe	03 - Loose snow	2	0	0	0
2/6/2018	2018	18:13	CARLING AVE @ CLYDE AVE/COLE AVE (0006984)	01 - Clear	07 - Dark	01 - Traffic signal	01 - Functioning	03 - P.D. only	05 - Turning movement	02 - Wet	2	0	0	0
2/9/2018	2018	12:58	CARLING AVE @ CLYDE AVE/COLE AVE (0006984)	01 - Clear	01 - Daylight	01 - Traffic signal	01 - Functioning	03 - P.D. only	03 - Rear end	02 - Wet	2	0	0	0
5/18/2018	2018	11:37	CARLING AVE @ CLYDE AVE/COLE AVE (0006984)	01 - Clear	01 - Daylight	01 - Traffic signal	01 - Functioning	03 - P.D. only	04 - Sideswipe	01 - Dry	2	0	0	0
5/12/2018	2018	14:30	CARLING AVE @ CLYDE AVE/COLE AVE (0006984)	01 - Clear	01 - Daylight	01 - Traffic signal	01 - Functioning	03 - P.D. only	05 - Turning movement	01 - Dry	2	0	0	0
1/9/2018	2018	21:41	CARLING AVE @ CLYDE AVE/COLE AVE (0006984)	01 - Clear	07 - Dark	01 - Traffic signal	01 - Functioning	03 - P.D. only	04 - Sideswipe	04 - Slush	2	0	0	0
5/31/2018	2018	8:11	CARLING AVE @ CLYDE AVE/COLE AVE (0006984)	01 - Clear	01 - Daylight	01 - Traffic signal	01 - Functioning	02 - Non-fatal injury	05 - Turning movement	01 - Dry	2	0	0	0
11/10/2018	2018	21:16	CARLING AVE @ CLYDE AVE/COLE AVE (0006984)	01 - Clear	07 - Dark	01 - Traffic signal	01 - Functioning	03 - P.D. only	05 - Turning movement	01 - Dry	2	0	0	0
1/13/2018	2018	10:12	CARLING AVE @ CLYDE AVE/COLE AVE (0006984)	05 - Drifting Snow	01 - Daylight	01 - Traffic signal	01 - Functioning	03 - P.D. only	04 - Sideswipe	06 - Ice	2	0	0	0
6/29/2018	2018	15:48	CARLING AVE @ CLYDE AVE/COLE AVE (0006984)	01 - Clear	01 - Daylight	01 - Traffic signal	01 - Functioning	03 - P.D. only	03 - Rear end	01 - Dry	2	0	0	0
8/11/2018	2018	12:51	CARLING AVE @ CLYDE AVE/COLE AVE (0006984)	01 - Clear	01 - Daylight	01 - Traffic signal	01 - Functioning	03 - P.D. only	05 - Turning movement	01 - Dry	2	0	0	0
8/23/2018	2018	16:20	CARLING AVE @ CLYDE AVE/COLE AVE (0006984)	01 - Clear	01 - Daylight	01 - Traffic signal	01 - Functioning	03 - P.D. only	05 - Turning movement	01 - Dry	2	0	0	0
8/17/2018	2018	10:38	CARLING AVE @ CLYDE AVE/COLE AVE (0006984)	01 - Clear	01 - Daylight	01 - Traffic signal	01 - Functioning	03 - P.D. only	05 - Turning movement	02 - Wet	3	0	0	0
10/17/2019	2019	6:50	CARLING AVE @ CLYDE AVE/COLE AVE (0006984)	02 - Rain	03 - Dawn	01 - Traffic signal	01 - Functioning	03 - P.D. only	04 - Sideswipe	02 - Wet	2	0	0	0
1/21/2019	2019	20:49	CARLING AVE @ CLYDE AVE/COLE AVE (0006984)	03 - Snow	07 - Dark	01 - Traffic signal	01 - Functioning	03 - P.D. only	02 - Angle	05 - Packed snow	2	0	0	0
1/25/2019	2019	10:49	CARLING AVE @ CLYDE AVE/COLE AVE (0006984)	01 - Clear	01 - Daylight	01 - Traffic signal	01 - Functioning	03 - P.D. only	04 - Sideswipe	04 - Slush	2	0	0	0
2/6/2019	2019	16:17	CARLING AVE @ CLYDE AVE/COLE AVE (0006984)	02 - Rain	01 - Daylight	01 - Traffic signal	01 - Functioning	03 - P.D. only	04 - Sideswipe	02 - Wet	2	0	0	0
5/21/2019	2019	18:53	CARLING AVE @ CLYDE AVE/COLE AVE (0006984)	01 - Clear	01 - Daylight	01 - Traffic signal	01 - Functioning	02 - Non-fatal injury	05 - Turning movement	01 - Dry	2	0	0	0
6/12/2019	2019	9:14	CARLING AVE @ CLYDE AVE/COLE AVE (0006984)	01 - Clear	01 - Daylight	01 - Traffic signal	01 - Functioning	02 - Non-fatal injury	03 - Rear end	01 - Dry	2	0	0	0
6/10/2019	2019	19:51	CARLING AVE @ CLYDE AVE/COLE AVE (0006984)	01 - Clear	01 - Daylight	01 - Traffic signal	01 - Functioning	03 - P.D. only	05 - Turning movement	01 - Dry	2	0	1	0
6/25/2019	2019	7:07	CARLING AVE @ CLYDE AVE/COLE AVE (0006984)	01 - Clear	01 - Daylight	01 - Traffic signal	01 - Functioning	02 - Non-fatal injury	05 - Turning movement	02 - Wet	3	0	0	0
1/3/2019	2019	11:46	CARLING AVE @ CLYDE AVE/COLE AVE (0006984)	01 - Clear	01 - Daylight	01 - Traffic signal	01 - Functioning	03 - P.D. only	03 - Rear end	01 - Dry	2	0	0	0
8/17/2019	2019	16:38	CARLING AVE @ CLYDE AVE/COLE AVE (0006984)	01 - Clear	01 - Daylight	01 - Traffic signal	01 - Functioning	03 - P.D. only	04 - Sideswipe	02 - Wet	2	0	0	0
1/21/2020	2020	17:53	CARLING AVE @ CLYDE AVE/COLE AVE (0006984)	01 - Clear	07 - Dark	01 - Traffic signal	01 - Functioning	02 - Non-fatal injury	07 - SMV other	01 - Dry	1	0	0	1
2/22/2020	2020	2:05	CARLING AVE @ CLYDE AVE/COLE AVE (0006984)	01 - Clear	07 - Dark	01 - Traffic signal	01 - Functioning	03 - Non-fatal injury	05 - Turning movement	01 - Dry	2	0	0	0
2/26/2020	2020	19:34	CARLING AVE @ CLYDE AVE/COLE AVE (0006984)	03 - Snow	07 - Dark	01 - Traffic signal	01 - Functioning	02 - Non-fatal injury	05 - Turning movement	04 - Slush	2	0	0	0
2/28/2020	2020	15:40	CARLING AVE @ CLYDE AVE/COLE AVE (0006984)	01 - Clear	01 - Daylight	01 - Traffic signal	02 - Not functioning	03 - P.D. only	05 - Turning movement	01 - Dry	2	0	0	0
3/12/2020	2020	12:00	CARLING AVE @ CLYDE AVE/COLE AVE (0006984)	01 - Clear	01 - Daylight	01 - Traffic signal	01 - Functioning	03 - P.D. only	99 - Other	01 - Dry	2	0	0	0
4/12/2020	2020	12:31	CARLING AVE @ CLYDE AVE/COLE AVE (0006984)	03 - Snow	01 - Daylight	01 - Traffic signal	01 - Functioning	03 - P.D. only	02 - Angle	02 - Wet	2	0	0	0
7/16/2020	2020	13:21	CARLING AVE @ CLYDE AVE/COLE AVE (0006984)	01 - Clear	01 - Daylight	01 - Traffic signal	01 - Functioning	03 - P.D. only	05 - Turning movement	01 - Dry	2	0	0	0
10/27/2020	2020	11:59	CARLING AVE @ CLYDE AVE/COLE AVE (0006984)	01 - Clear	01 - Daylight	01 - Traffic signal	01 - Functioning	02 - Non-fatal injury	05 - Turning movement	01 - Dry	2	0	0	0
10/7/2020	2020	11:33	CARLING AVE @ CLYDE AVE/COLE AVE (0006984)	01 - Clear	01 - Daylight	01 - Traffic signal	01 - Functioning	02 - Non-fatal injury	03 - Rear end	01 - Dry	2	0	0	0
9/29/2020	2020	19:44	CARLING AVE @ CLYDE AVE/COLE AVE (0006984)	01 - Clear	07 - Dark	01 - Traffic signal	01 - Functioning	02 - Non-fatal injury	05 - Turning movement	01 - Dry	2	0	0	0
3/4/2016	2016	11:19	CARLING AVE @ CHURCHILL AVE (0002149)	01 - Clear	01 - Daylight	01 - Traffic signal	01 - Functioning	03 - P.D. only	03 - Rear end	01 - Dry	2	0	0	0
5/4/2016	2016	13:41	CARLING AVE @ CHURCHILL AVE (0002149)	01 - Clear	01 - Daylight	01 - Traffic signal	01 - Functioning	03 - P.D. only	03 - Rear end	01 - Dry	2	0	0	0
7/8/2016	2016	14:38	CARLING AVE @ CHURCHILL AVE (0002149)	01 - Clear	01 - Daylight	01 - Traffic signal	01 - Functioning	03 - P.D. only	04 - Sideswipe	01 - Dry	2	0	0	0
2/10/2017	2017	9:52	CARLING AVE @ CHURCHILL AVE (0002149)	01 - Clear	01 - Daylight	01 - Traffic signal	01 - Functioning	03 - P.D. only	03 - Rear end	01 - Dry	2	0	0	0
7/15/2017	2017	16:45	CARLING AVE @ CHURCHILL AVE (0002149)	01 - Clear	01 - Daylight	01 - Traffic signal	01 - Functioning	03 - P.D. only	02 - Angle	01 - Dry	2	0	0	0
8/15/2017	2017	15:00	CARLING AVE @ CHURCHILL AVE (0002149)	01 - Clear	01 - Daylight	01 - Traffic signal	01 - Functioning	03 - P.D. only	05 - Turning movement	01 - Dry	2	0	0	0
9/20/2017	2017	19:20	CARLING AVE @ CHURCHILL AVE (0002149)	01 - Clear	05 - Dusk	01 - Traffic signal	00 - Unknown	03 - P.D. only	04 - Sideswipe	01 - Dry	2	0	0	0
10/12/2018	2018	10:20	CARLING AVE @ CHURCHILL AVE (0002149)	01 - Clear	01 - Daylight	01 - Traffic signal	01 - Functioning	03 - P.D. only	03 - Rear end	01 - Dry	2	0	0	0
12/25/2018	2018	12:19	CARLING AVE @ CHURCHILL AVE (0002149)	01 - Clear	01 - Daylight	01 - Traffic signal	01 - Functioning	02 - Non-fatal injury	03 - Rear end	01 - Dry	2	0	0	0
2/27/2018	2018	11:26	CARLING AVE @ CHURCHILL AVE (0002149)	01 - Clear	01 - Daylight	01 - Traffic signal	01 - Functioning	03 - P.D. only	04 - Sideswipe	01 - Dry	2	0	0	0
3/27/2018	2018	10:50	CARLING AVE @ CHURCHILL AVE (0002149)	01 - Clear	01 - Daylight	01 - Traffic signal	01 - Functioning	02 - Non-fatal injury	07 - SMV other	01 - Dry	1	0	0	0
7/23/2018	2018	18:59	CARLING AVE @ CHURCHILL AVE (0002149)	01 - Clear	01 - Daylight	01 - Traffic signal	01 - Functioning	02 - Non-fatal injury	03 - Rear end	01 - Dry	2	0	0	0
9/4/2018	2018	8:30	CARLING AVE @ CHURCHILL AVE (0002149)	01 - Clear	01 - Daylight	01 - Traffic signal	01 - Functioning	03 - P.D. only	04 - Sideswipe	01 - Dry	2	0	0	0
11/16/2018	2018	18:18	CARLING AVE @ CHURCHILL AVE (0002149)	01 - Clear	07 - Dark	01 - Traffic signal	01 - Functioning	03 - P.D. only	03 - Rear end	04 - Slush	2	0	0	0
9/5/2018	2018	8:46	CARLING AVE @ CHURCHILL AVE (0002149)	01 - Clear	01 - Daylight	01 - Traffic signal	01 - Functioning	03 - P.D. only	03 - Rear end	01 - Dry	2	0	0	0
8/27/2018	2018	12:02	CARLING AVE @ CHURCHILL AVE (0002149)	01 - Clear	01 - Daylight	01 - Traffic signal	01 - Functioning	03 - P.D. only	04 - Sideswipe	01 - Dry	2	0	0	0
9/24/2019	2019	15:15	CARLING AVE @ CHURCHILL AVE (000214											

Appendix E

Carling Avenue Transit Priority Measures Plan

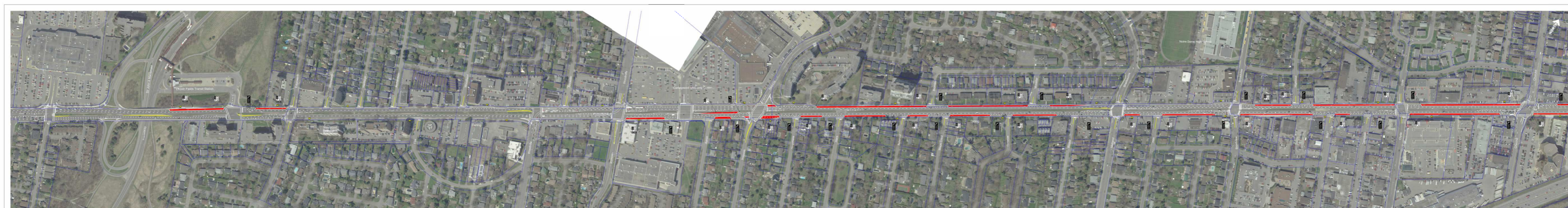

Appendix F

TDM Checklist

TDM-Supportive Development Design and Infrastructure Checklist:
Non-Residential Developments (office, institutional, retail or industrial)

Legend	
REQUIRED	The Official Plan or Zoning By-law provides related guidance that must be followed
BASIC	The measure is generally feasible and effective, and in most cases would benefit the development and its users
BETTER	The measure could maximize support for users of sustainable modes, and optimize development performance

TDM-supportive design & infrastructure measures: <i>Non-residential developments</i>		Check if completed & add descriptions, explanations or plan/drawing references
1. WALKING & CYCLING: ROUTES		
1.1 Building location & access points		
BASIC	1.1.1 Locate building close to the street, and do not locate parking areas between the street and building entrances	<input type="checkbox"/>
BASIC	1.1.2 Locate building entrances in order to minimize walking distances to sidewalks and transit stops/stations	<input type="checkbox"/>
BASIC	1.1.3 Locate building doors and windows to ensure visibility of pedestrians from the building, for their security and comfort	<input type="checkbox"/>
1.2 Facilities for walking & cycling		
REQUIRED	1.2.1 Provide convenient, direct access to stations or major stops along rapid transit routes within 600 metres; minimize walking distances from buildings to rapid transit; provide pedestrian-friendly, weather-protected (where possible) environment between rapid transit accesses and building entrances; ensure quality linkages from sidewalks through building entrances to integrated stops/stations (see <i>Official Plan policy 4.3.3</i>)	<input type="checkbox"/>
REQUIRED	1.2.2 Provide safe, direct and attractive pedestrian access from public sidewalks to building entrances through such measures as: reducing distances between public sidewalks and major building entrances; providing walkways from public streets to major building entrances; within a site, providing walkways along the front of adjoining buildings, between adjacent buildings, and connecting areas where people may congregate, such as courtyards and transit stops; and providing weather protection through canopies, colonnades, and other design elements wherever possible (see <i>Official Plan policy 4.3.12</i>)	<input checked="" type="checkbox"/>

TDM-supportive design & infrastructure measures: <i>Non-residential developments</i>		Check if completed & add descriptions, explanations or plan/drawing references
REQUIRED	1.2.3 Provide sidewalks of smooth, well-drained walking surfaces of contrasting materials or treatments to differentiate pedestrian areas from vehicle areas, and provide marked pedestrian crosswalks at intersection sidewalks (see <i>Official Plan policy 4.3.10</i>)	<input checked="" type="checkbox"/>
REQUIRED	1.2.4 Make sidewalks and open space areas easily accessible through features such as gradual grade transition, depressed curbs at street corners and convenient access to extra-wide parking spaces and ramps (see <i>Official Plan policy 4.3.10</i>)	<input checked="" type="checkbox"/>
REQUIRED	1.2.5 Include adequately spaced inter-block/street cycling and pedestrian connections to facilitate travel by active transportation. Provide links to the existing or planned network of public sidewalks, multi-use pathways and on-road cycle routes. Where public sidewalks and multi-use pathways intersect with roads, consider providing traffic control devices to give priority to cyclists and pedestrians (see <i>Official Plan policy 4.3.11</i>)	<input checked="" type="checkbox"/>
BASIC	1.2.6 Provide safe, direct and attractive walking routes from building entrances to nearby transit stops	<input type="checkbox"/>
BASIC	1.2.7 Ensure that walking routes to transit stops are secure, visible, lighted, shaded and wind-protected wherever possible	<input type="checkbox"/>
BASIC	1.2.8 Design roads used for access or circulation by cyclists using a target operating speed of no more than 30 km/h, or provide a separated cycling facility	<input type="checkbox"/>
1.3 Amenities for walking & cycling		
BASIC	1.3.1 Provide lighting, landscaping and benches along walking and cycling routes between building entrances and streets, sidewalks and trails	<input type="checkbox"/>
BASIC	1.3.2 Provide wayfinding signage for site access (where required, e.g. when multiple buildings or entrances exist) and egress (where warranted, such as when directions to reach transit stops/stations, trails or other common destinations are not obvious)	<input type="checkbox"/>

TDM-supportive design & infrastructure measures: <i>Non-residential developments</i>		Check if completed & add descriptions, explanations or plan/drawing references
2. WALKING & CYCLING: END-OF-TRIP FACILITIES		
2.1 Bicycle parking		
REQUIRED	2.1.1 Provide bicycle parking in highly visible and lighted areas, sheltered from the weather wherever possible (see <i>Official Plan policy 4.3.6</i>)	<input checked="" type="checkbox"/>
REQUIRED	2.1.2 Provide the number of bicycle parking spaces specified for various land uses in different parts of Ottawa; provide convenient access to main entrances or well-used areas (see <i>Zoning By-law Section 111</i>)	<input checked="" type="checkbox"/>
REQUIRED	2.1.3 Ensure that bicycle parking spaces and access aisles meet minimum dimensions; that no more than 50% of spaces are vertical spaces; and that parking racks are securely anchored (see <i>Zoning By-law Section 111</i>)	<input checked="" type="checkbox"/>
BASIC	2.1.4 Provide bicycle parking spaces equivalent to the expected number of commuter cyclists (assuming the cycling mode share target is met), plus the expected peak number of customer/visitor cyclists	<input type="checkbox"/>
BETTER	2.1.5 Provide bicycle parking spaces equivalent to the expected number of commuter and customer/visitor cyclists, plus an additional buffer (e.g. 25 percent extra) to encourage other cyclists and ensure adequate capacity in peak cycling season	<input type="checkbox"/>
2.2 Secure bicycle parking		
REQUIRED	2.2.1 Where more than 50 bicycle parking spaces are provided for a single office building, locate at least 25% of spaces within a building/structure, a secure area (e.g. supervised parking lot or enclosure) or bicycle lockers (see <i>Zoning By-law Section 111</i>)	<input type="checkbox"/>
BETTER	2.2.2 Provide secure bicycle parking spaces equivalent to the expected number of commuter cyclists (assuming the cycling mode share target is met)	<input type="checkbox"/>
2.3 Shower & change facilities		
BASIC	2.3.1 Provide shower and change facilities for the use of active commuters	<input type="checkbox"/>
BETTER	2.3.2 In addition to shower and change facilities, provide dedicated lockers, grooming stations, drying racks and laundry facilities for the use of active commuters	<input type="checkbox"/>
2.4 Bicycle repair station		
BETTER	2.4.1 Provide a permanent bike repair station, with commonly used tools and an air pump, adjacent to the main bicycle parking area (or secure bicycle parking area, if provided)	<input type="checkbox"/>

TDM-supportive design & infrastructure measures: <i>Non-residential developments</i>		Check if completed & add descriptions, explanations or plan/drawing references
3. TRANSIT		
3.1 Customer amenities		
BASIC	3.1.1 Provide shelters, lighting and benches at any on-site transit stops	<input type="checkbox"/>
BASIC	3.1.2 Where the site abuts an off-site transit stop and insufficient space exists for a transit shelter in the public right-of-way, protect land for a shelter and/or install a shelter	<input type="checkbox"/>
BETTER	3.1.3 Provide a secure and comfortable interior waiting area by integrating any on-site transit stops into the building	<input type="checkbox"/>
4. RIDESHARING		
4.1 Pick-up & drop-off facilities		
BASIC	4.1.1 Provide a designated area for carpool drivers (plus taxis and ride-hailing services) to drop off or pick up passengers without using fire lanes or other no-stopping zones	<input type="checkbox"/>
4.2 Carpool parking		
BASIC	4.2.1 Provide signed parking spaces for carpools in a priority location close to a major building entrance, sufficient in number to accommodate the mode share target for carpools	<input type="checkbox"/>
BETTER	4.2.2 At large developments, provide spaces for carpools in a separate, access-controlled parking area to simplify enforcement	<input type="checkbox"/>
5. CARSHARING & BIKESHARING		
5.1 Carshare parking spaces		
BETTER	5.1.1 Provide carshare parking spaces in permitted non-residential zones, occupying either required or provided parking spaces (see <i>Zoning By-law Section 94</i>)	<input type="checkbox"/>
5.2 Bikeshare station location		
BETTER	5.2.1 Provide a designated bikeshare station area near a major building entrance, preferably lighted and sheltered with a direct walkway connection	<input type="checkbox"/>

TDM-supportive design & infrastructure measures: <i>Non-residential developments</i>		Check if completed & add descriptions, explanations or plan/drawing references
6. PARKING		
6.1 Number of parking spaces		
REQUIRED	6.1.1 Do not provide more parking than permitted by zoning, nor less than required by zoning, unless a variance is being applied for	<input checked="" type="checkbox"/>
BASIC	6.1.2 Provide parking for long-term and short-term users that is consistent with mode share targets, considering the potential for visitors to use off-site public parking	<input type="checkbox"/>
BASIC	6.1.3 Where a site features more than one use, provide shared parking and reduce the cumulative number of parking spaces accordingly (see <i>Zoning By-law Section 104</i>)	<input type="checkbox"/>
BETTER	6.1.4 Reduce the minimum number of parking spaces required by zoning by one space for each 13 square metres of gross floor area provided as shower rooms, change rooms, locker rooms and other facilities for cyclists in conjunction with bicycle parking (see <i>Zoning By-law Section 111</i>)	<input type="checkbox"/>
6.2 Separate long-term & short-term parking areas		
BETTER	6.2.1 Separate short-term and long-term parking areas using signage or physical barriers, to permit access controls and simplify enforcement (i.e. to discourage employees from parking in visitor spaces, and vice versa)	<input type="checkbox"/>
7. OTHER		
7.1 On-site amenities to minimize off-site trips		
BETTER	7.1.1 Provide on-site amenities to minimize mid-day or mid-commute errands	<input type="checkbox"/>

**TDM-Supportive Development Design and Infrastructure Checklist:
Residential Developments (multi-family or condominium)**

Legend	
REQUIRED	The Official Plan or Zoning By-law provides related guidance that must be followed
BASIC	The measure is generally feasible and effective, and in most cases would benefit the development and its users
BETTER	The measure could maximize support for users of sustainable modes, and optimize development performance

TDM-supportive design & infrastructure measures: <i>Residential developments</i>		Check if completed & add descriptions, explanations or plan/drawing references
1. WALKING & CYCLING: ROUTES		
1.1 Building location & access points		
BASIC	1.1.1 Locate building close to the street, and do not locate parking areas between the street and building entrances	<input type="checkbox"/>
BASIC	1.1.2 Locate building entrances in order to minimize walking distances to sidewalks and transit stops/stations	<input type="checkbox"/>
BASIC	1.1.3 Locate building doors and windows to ensure visibility of pedestrians from the building, for their security and comfort	<input type="checkbox"/>
1.2 Facilities for walking & cycling		
REQUIRED	1.2.1 Provide convenient, direct access to stations or major stops along rapid transit routes within 600 metres; minimize walking distances from buildings to rapid transit; provide pedestrian-friendly, weather-protected (where possible) environment between rapid transit accesses and building entrances; ensure quality linkages from sidewalks through building entrances to integrated stops/stations (see <i>Official Plan policy 4.3.3</i>)	<input type="checkbox"/>
REQUIRED	1.2.2 Provide safe, direct and attractive pedestrian access from public sidewalks to building entrances through such measures as: reducing distances between public sidewalks and major building entrances; providing walkways from public streets to major building entrances; within a site, providing walkways along the front of adjoining buildings, between adjacent buildings, and connecting areas where people may congregate, such as courtyards and transit stops; and providing weather protection through canopies, colonnades, and other design elements wherever possible (see <i>Official Plan policy 4.3.12</i>)	<input checked="" type="checkbox"/>

TDM-supportive design & infrastructure measures: <i>Residential developments</i>		Check if completed & add descriptions, explanations or plan/drawing references
REQUIRED	1.2.3 Provide sidewalks of smooth, well-drained walking surfaces of contrasting materials or treatments to differentiate pedestrian areas from vehicle areas, and provide marked pedestrian crosswalks at intersection sidewalks (see <i>Official Plan policy 4.3.10</i>)	<input checked="" type="checkbox"/>
REQUIRED	1.2.4 Make sidewalks and open space areas easily accessible through features such as gradual grade transition, depressed curbs at street corners and convenient access to extra-wide parking spaces and ramps (see <i>Official Plan policy 4.3.10</i>)	<input checked="" type="checkbox"/>
REQUIRED	1.2.5 Include adequately spaced inter-block/street cycling and pedestrian connections to facilitate travel by active transportation. Provide links to the existing or planned network of public sidewalks, multi-use pathways and on-road cycle routes. Where public sidewalks and multi-use pathways intersect with roads, consider providing traffic control devices to give priority to cyclists and pedestrians (see <i>Official Plan policy 4.3.11</i>)	<input checked="" type="checkbox"/>
BASIC	1.2.6 Provide safe, direct and attractive walking routes from building entrances to nearby transit stops	<input type="checkbox"/>
BASIC	1.2.7 Ensure that walking routes to transit stops are secure, visible, lighted, shaded and wind-protected wherever possible	<input type="checkbox"/>
BASIC	1.2.8 Design roads used for access or circulation by cyclists using a target operating speed of no more than 30 km/h, or provide a separated cycling facility	<input type="checkbox"/>
1.3 Amenities for walking & cycling		
BASIC	1.3.1 Provide lighting, landscaping and benches along walking and cycling routes between building entrances and streets, sidewalks and trails	<input type="checkbox"/>
BASIC	1.3.2 Provide wayfinding signage for site access (where required, e.g. when multiple buildings or entrances exist) and egress (where warranted, such as when directions to reach transit stops/stations, trails or other common destinations are not obvious)	<input type="checkbox"/>

TDM-supportive design & infrastructure measures: <i>Residential developments</i>		Check if completed & add descriptions, explanations or plan/drawing references
2. WALKING & CYCLING: END-OF-TRIP FACILITIES		
2.1 Bicycle parking		
REQUIRED	2.1.1 Provide bicycle parking in highly visible and lighted areas, sheltered from the weather wherever possible (see <i>Official Plan policy 4.3.6</i>)	<input checked="" type="checkbox"/>
REQUIRED	2.1.2 Provide the number of bicycle parking spaces specified for various land uses in different parts of Ottawa; provide convenient access to main entrances or well-used areas (see <i>Zoning By-law Section 111</i>)	<input checked="" type="checkbox"/>
REQUIRED	2.1.3 Ensure that bicycle parking spaces and access aisles meet minimum dimensions; that no more than 50% of spaces are vertical spaces; and that parking racks are securely anchored (see <i>Zoning By-law Section 111</i>)	<input checked="" type="checkbox"/>
BASIC	2.1.4 Provide bicycle parking spaces equivalent to the expected number of resident-owned bicycles, plus the expected peak number of visitor cyclists	<input checked="" type="checkbox"/>
2.2 Secure bicycle parking		
REQUIRED	2.2.1 Where more than 50 bicycle parking spaces are provided for a single residential building, locate at least 25% of spaces within a building/structure, a secure area (e.g. supervised parking lot or enclosure) or bicycle lockers (see <i>Zoning By-law Section 111</i>)	<input checked="" type="checkbox"/>
BETTER	2.2.2 Provide secure bicycle parking spaces equivalent to at least the number of units at condominiums or multi-family residential developments	<input type="checkbox"/>
2.3 Bicycle repair station		
BETTER	2.3.1 Provide a permanent bike repair station, with commonly used tools and an air pump, adjacent to the main bicycle parking area (or secure bicycle parking area, if provided)	<input type="checkbox"/>
3. TRANSIT		
3.1 Customer amenities		
BASIC	3.1.1 Provide shelters, lighting and benches at any on-site transit stops	<input type="checkbox"/>
BASIC	3.1.2 Where the site abuts an off-site transit stop and insufficient space exists for a transit shelter in the public right-of-way, protect land for a shelter and/or install a shelter	<input type="checkbox"/>
BETTER	3.1.3 Provide a secure and comfortable interior waiting area by integrating any on-site transit stops into the building	<input type="checkbox"/>

TDM-supportive design & infrastructure measures: <i>Residential developments</i>		Check if completed & add descriptions, explanations or plan/drawing references
4. RIDESHARING		
4.1 Pick-up & drop-off facilities		
BASIC	4.1.1 Provide a designated area for carpool drivers (plus taxis and ride-hailing services) to drop off or pick up passengers without using fire lanes or other no-stopping zones	<input type="checkbox"/>
5. CARSHARING & BIKESHARING		
5.1 Carshare parking spaces		
BETTER	5.1.1 Provide up to three carshare parking spaces in an R3, R4 or R5 Zone for specified residential uses (see <i>Zoning By-law Section 94</i>)	<input type="checkbox"/>
5.2 Bikeshare station location		
BETTER	5.2.1 Provide a designated bikeshare station area near a major building entrance, preferably lighted and sheltered with a direct walkway connection	<input type="checkbox"/>
6. PARKING		
6.1 Number of parking spaces		
REQUIRED	6.1.1 Do not provide more parking than permitted by zoning, nor less than required by zoning, unless a variance is being applied for	<input checked="" type="checkbox"/>
BASIC	6.1.2 Provide parking for long-term and short-term users that is consistent with mode share targets, considering the potential for visitors to use off-site public parking	<input type="checkbox"/>
BASIC	6.1.3 Where a site features more than one use, provide shared parking and reduce the cumulative number of parking spaces accordingly (see <i>Zoning By-law Section 104</i>)	<input type="checkbox"/>
BETTER	6.1.4 Reduce the minimum number of parking spaces required by zoning by one space for each 13 square metres of gross floor area provided as shower rooms, change rooms, locker rooms and other facilities for cyclists in conjunction with bicycle parking (see <i>Zoning By-law Section 111</i>)	<input type="checkbox"/>
6.2 Separate long-term & short-term parking areas		
BETTER	6.2.1 Provide separate areas for short-term and long-term parking (using signage or physical barriers) to permit access controls and simplify enforcement (i.e. to discourage residents from parking in visitor spaces, and vice versa)	<input type="checkbox"/>

TDM Measures Checklist:
Non-Residential Developments (office, institutional, retail or industrial)

Legend	
BASIC	The measure is generally feasible and effective, and in most cases would benefit the development and its users
BETTER	The measure could maximize support for users of sustainable modes, and optimize development performance
★	The measure is one of the most dependably effective tools to encourage the use of sustainable modes

TDM measures: <i>Non-residential developments</i>		Check if proposed & add descriptions
1. TDM PROGRAM MANAGEMENT		
1.1 Program coordinator		
BASIC ★	1.1.1 Designate an internal coordinator, or contract with an external coordinator	<input type="checkbox"/>
1.2 Travel surveys		
BETTER	1.2.1 Conduct periodic surveys to identify travel-related behaviours, attitudes, challenges and solutions, and to track progress	<input type="checkbox"/>
2. WALKING AND CYCLING		
2.1 Information on walking/cycling routes & destinations		
BASIC	2.1.1 Display local area maps with walking/cycling access routes and key destinations at major entrances	<input type="checkbox"/>
2.2 Bicycle skills training		
<i>Commuter travel</i>		
BETTER ★	2.2.1 Offer on-site cycling courses for commuters, or subsidize off-site courses	<input type="checkbox"/>
2.3 Valet bike parking		
<i>Visitor travel</i>		
BETTER	2.3.1 Offer secure valet bike parking during public events when demand exceeds fixed supply (e.g. for festivals, concerts, games)	<input type="checkbox"/>

TDM measures: <i>Non-residential developments</i>		Check if proposed & add descriptions
3. TRANSIT		
3.1 Transit information		
BASIC	3.1.1 Display relevant transit schedules and route maps at entrances	<input type="checkbox"/>
BASIC	3.1.2 Provide online links to OC Transpo and STO information	<input type="checkbox"/>
BETTER	3.1.3 Provide real-time arrival information display at entrances	<input type="checkbox"/>
3.2 Transit fare incentives		
<i>Commuter travel</i>		
BETTER	3.2.1 Offer preloaded PRESTO cards to encourage commuters to use transit	<input type="checkbox"/>
BETTER ★	3.2.2 Subsidize or reimburse monthly transit pass purchases by employees	<input type="checkbox"/>
<i>Visitor travel</i>		
BETTER	3.2.3 Arrange inclusion of same-day transit fare in price of tickets (e.g. for festivals, concerts, games)	<input type="checkbox"/>
3.3 Enhanced public transit service		
<i>Commuter travel</i>		
BETTER	3.3.1 Contract with OC Transpo to provide enhanced transit services (e.g. for shift changes, weekends)	<input type="checkbox"/>
<i>Visitor travel</i>		
BETTER	3.3.2 Contract with OC Transpo to provide enhanced transit services (e.g. for festivals, concerts, games)	<input type="checkbox"/>
3.4 Private transit service		
<i>Commuter travel</i>		
BETTER	3.4.1 Provide shuttle service when OC Transpo cannot offer sufficient quality or capacity to serve demand (e.g. for shift changes, weekends)	<input type="checkbox"/>
<i>Visitor travel</i>		
BETTER	3.4.2 Provide shuttle service when OC Transpo cannot offer sufficient quality or capacity to serve demand (e.g. for festivals, concerts, games)	<input type="checkbox"/>

TDM measures: <i>Non-residential developments</i>		Check if proposed & add descriptions
4. RIDESHARING		
4.1 Ridematching service		
<i>Commuter travel</i>		
BASIC ★	4.1.1 Provide a dedicated ridematching portal at OttawaRideMatch.com	<input type="checkbox"/>
4.2 Carpool parking price incentives		
<i>Commuter travel</i>		
BETTER	4.2.1 Provide discounts on parking costs for registered carpools	<input type="checkbox"/>
4.3 Vanpool service		
<i>Commuter travel</i>		
BETTER	4.3.1 Provide a vanpooling service for long-distance commuters	<input type="checkbox"/>
5. CARSHARING & BIKESHARING		
5.1 Bikeshare stations & memberships		
BETTER	5.1.1 Contract with provider to install on-site bikeshare station for use by commuters and visitors	<input type="checkbox"/>
<i>Commuter travel</i>		
BETTER	5.1.2 Provide employees with bikeshare memberships for local business travel	<input type="checkbox"/>
5.2 Carshare vehicles & memberships		
<i>Commuter travel</i>		
BETTER	5.2.1 Contract with provider to install on-site carshare vehicles and promote their use by tenants	<input type="checkbox"/>
BETTER	5.2.2 Provide employees with carshare memberships for local business travel	<input type="checkbox"/>
6. PARKING		
6.1 Priced parking		
<i>Commuter travel</i>		
BASIC ★	6.1.1 Charge for long-term parking (daily, weekly, monthly)	<input type="checkbox"/>
BASIC	6.1.2 Unbundle parking cost from lease rates at multi-tenant sites	<input type="checkbox"/>
<i>Visitor travel</i>		
BETTER	6.1.3 Charge for short-term parking (hourly)	<input type="checkbox"/>

TDM measures: <i>Non-residential developments</i>		Check if proposed & add descriptions
7. TDM MARKETING & COMMUNICATIONS		
7.1 Multimodal travel information		
<i>Commuter travel</i>		
BASIC	★ 7.1.1 Provide a multimodal travel option information package to new/relocating employees and students	<input checked="" type="checkbox"/>
<i>Visitor travel</i>		
BETTER	★ 7.1.2 Include multimodal travel option information in invitations or advertising that attract visitors or customers (e.g. for festivals, concerts, games)	<input type="checkbox"/>
7.2 Personalized trip planning		
<i>Commuter travel</i>		
BETTER	★ 7.2.1 Offer personalized trip planning to new/relocating employees	<input type="checkbox"/>
7.3 Promotions		
<i>Commuter travel</i>		
BETTER	7.3.1 Deliver promotions and incentives to maintain awareness, build understanding, and encourage trial of sustainable modes	<input type="checkbox"/>
8. OTHER INCENTIVES & AMENITIES		
8.1 Emergency ride home		
<i>Commuter travel</i>		
BETTER	★ 8.1.1 Provide emergency ride home service to non-driving commuters	<input type="checkbox"/>
8.2 Alternative work arrangements		
<i>Commuter travel</i>		
BASIC	★ 8.2.1 Encourage flexible work hours	<input type="checkbox"/>
BETTER	8.2.2 Encourage compressed workweeks	<input type="checkbox"/>
BETTER	★ 8.2.3 Encourage telework	<input type="checkbox"/>
8.3 Local business travel options		
<i>Commuter travel</i>		
BASIC	★ 8.3.1 Provide local business travel options that minimize the need for employees to bring a personal car to work	<input type="checkbox"/>
8.4 Commuter incentives		
<i>Commuter travel</i>		
BETTER	8.4.1 Offer employees a taxable, mode-neutral commuting allowance	<input type="checkbox"/>
8.5 On-site amenities		
<i>Commuter travel</i>		
BETTER	8.5.1 Provide on-site amenities/services to minimize mid-day or mid-commute errands	<input type="checkbox"/>

TDM Measures Checklist:
Residential Developments (multi-family, condominium or subdivision)

Legend	
BASIC	The measure is generally feasible and effective, and in most cases would benefit the development and its users
BETTER	The measure could maximize support for users of sustainable modes, and optimize development performance
★	The measure is one of the most dependably effective tools to encourage the use of sustainable modes

TDM measures: <i>Residential developments</i>		Check if proposed & add descriptions
1. TDM PROGRAM MANAGEMENT		
1.1 Program coordinator		
BASIC	★ 1.1.1 Designate an internal coordinator, or contract with an external coordinator	<input type="checkbox"/>
1.2 Travel surveys		
BETTER	1.2.1 Conduct periodic surveys to identify travel-related behaviours, attitudes, challenges and solutions, and to track progress	<input type="checkbox"/>
2. WALKING AND CYCLING		
2.1 Information on walking/cycling routes & destinations		
BASIC	2.1.1 Display local area maps with walking/cycling access routes and key destinations at major entrances (<i>multi-family, condominium</i>)	<input checked="" type="checkbox"/>
2.2 Bicycle skills training		
BETTER	2.2.1 Offer on-site cycling courses for residents, or subsidize off-site courses	<input type="checkbox"/>

TDM measures: Residential developments		Check if proposed & add descriptions
3. TRANSIT		
3.1 Transit information		
BASIC	3.1.1 Display relevant transit schedules and route maps at entrances (<i>multi-family, condominium</i>)	<input checked="" type="checkbox"/>
BETTER	3.1.2 Provide real-time arrival information display at entrances (<i>multi-family, condominium</i>)	<input type="checkbox"/>
3.2 Transit fare incentives		
BASIC ★	3.2.1 Offer PRESTO cards preloaded with one monthly transit pass on residence purchase/move-in, to encourage residents to use transit	<input type="checkbox"/>
BETTER	3.2.2 Offer at least one year of free monthly transit passes on residence purchase/move-in	<input checked="" type="checkbox"/>
3.3 Enhanced public transit service		
BETTER ★	3.3.1 Contract with OC Transpo to provide early transit services until regular services are warranted by occupancy levels (<i>subdivision</i>)	<input type="checkbox"/>
3.4 Private transit service		
BETTER	3.4.1 Provide shuttle service for seniors homes or lifestyle communities (e.g. scheduled mall or supermarket runs)	<input type="checkbox"/>
4. CARSHARING & BIKESHARING		
4.1 Bikeshare stations & memberships		
BETTER	4.1.1 Contract with provider to install on-site bikeshare station (<i>multi-family</i>)	<input checked="" type="checkbox"/>
BETTER	4.1.2 Provide residents with bikeshare memberships, either free or subsidized (<i>multi-family</i>)	<input type="checkbox"/>
4.2 Carshare vehicles & memberships		
BETTER	4.2.1 Contract with provider to install on-site carshare vehicles and promote their use by residents	<input checked="" type="checkbox"/>
BETTER	4.2.2 Provide residents with carshare memberships, either free or subsidized	<input type="checkbox"/>
5. PARKING		
5.1 Priced parking		
BASIC ★	5.1.1 Unbundle parking cost from purchase price (<i>condominium</i>)	<input checked="" type="checkbox"/>
BASIC ★	5.1.2 Unbundle parking cost from monthly rent (<i>multi-family</i>)	<input checked="" type="checkbox"/>

TDM measures: Residential developments		Check if proposed & add descriptions
6. TDM MARKETING & COMMUNICATIONS		
6.1 Multimodal travel information		
BASIC ★	6.1.1 Provide a multimodal travel option information package to new residents	<input checked="" type="checkbox"/>
6.2 Personalized trip planning		
BETTER ★	6.2.1 Offer personalized trip planning to new residents	<input type="checkbox"/>

Appendix G

Turing Templates

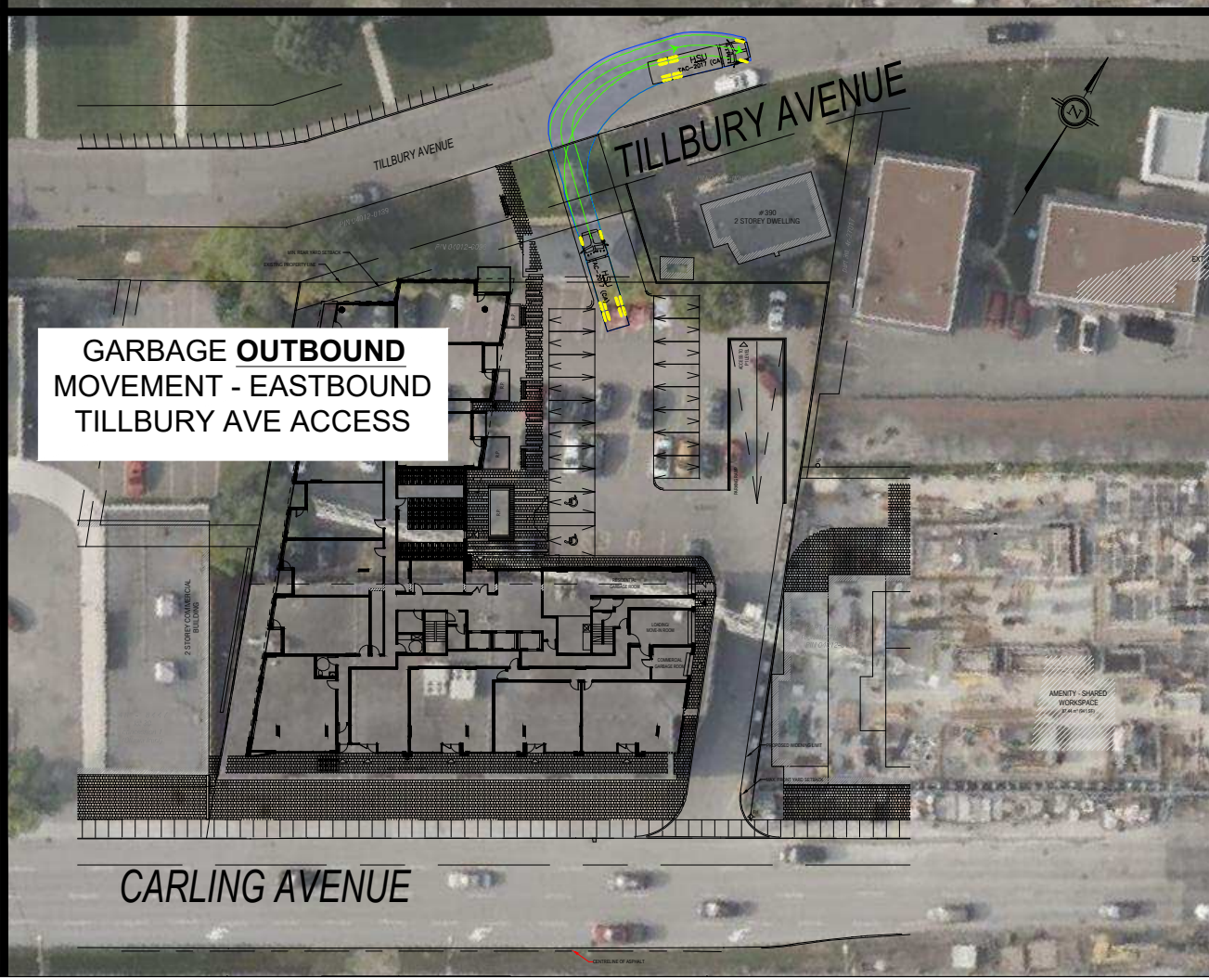
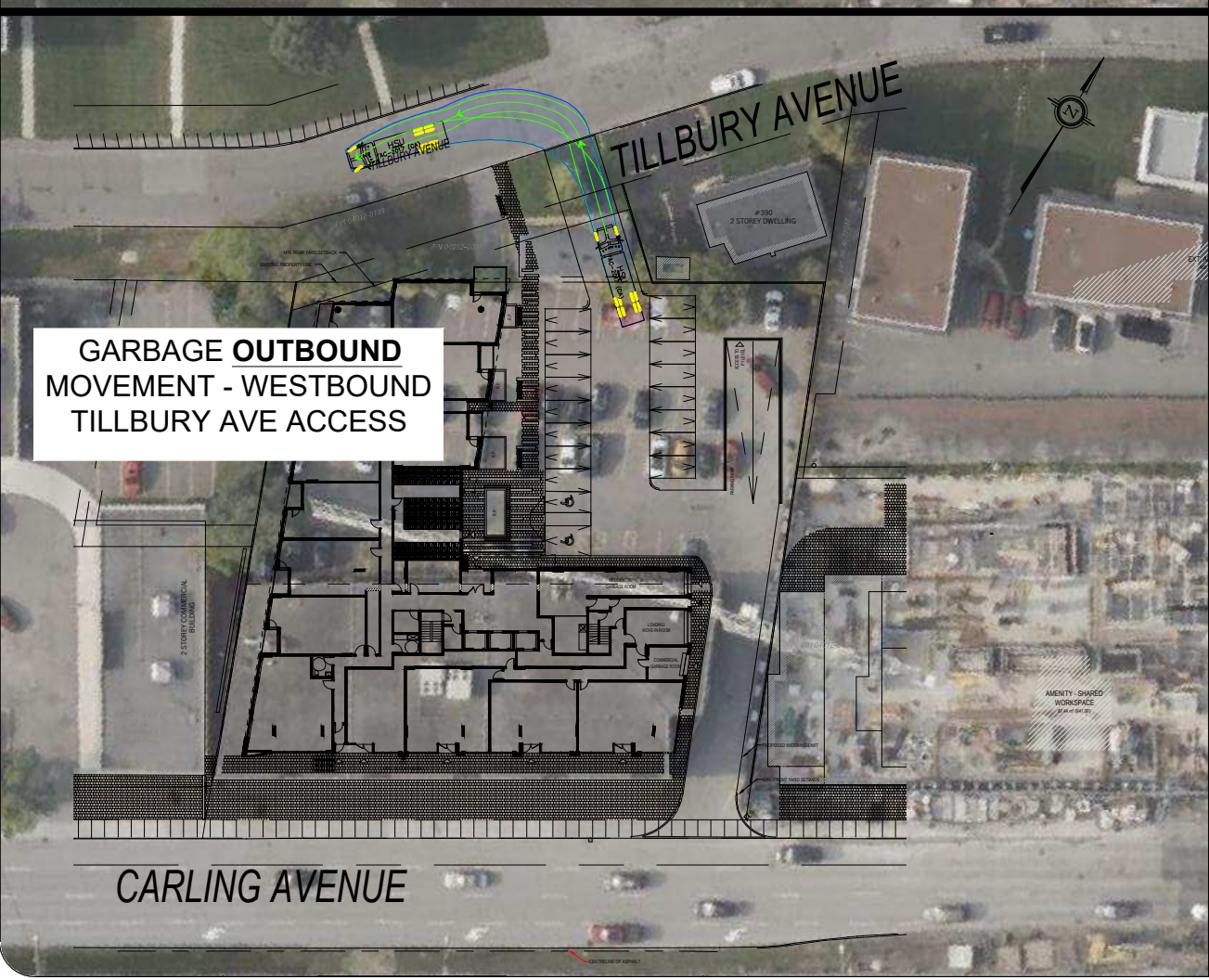
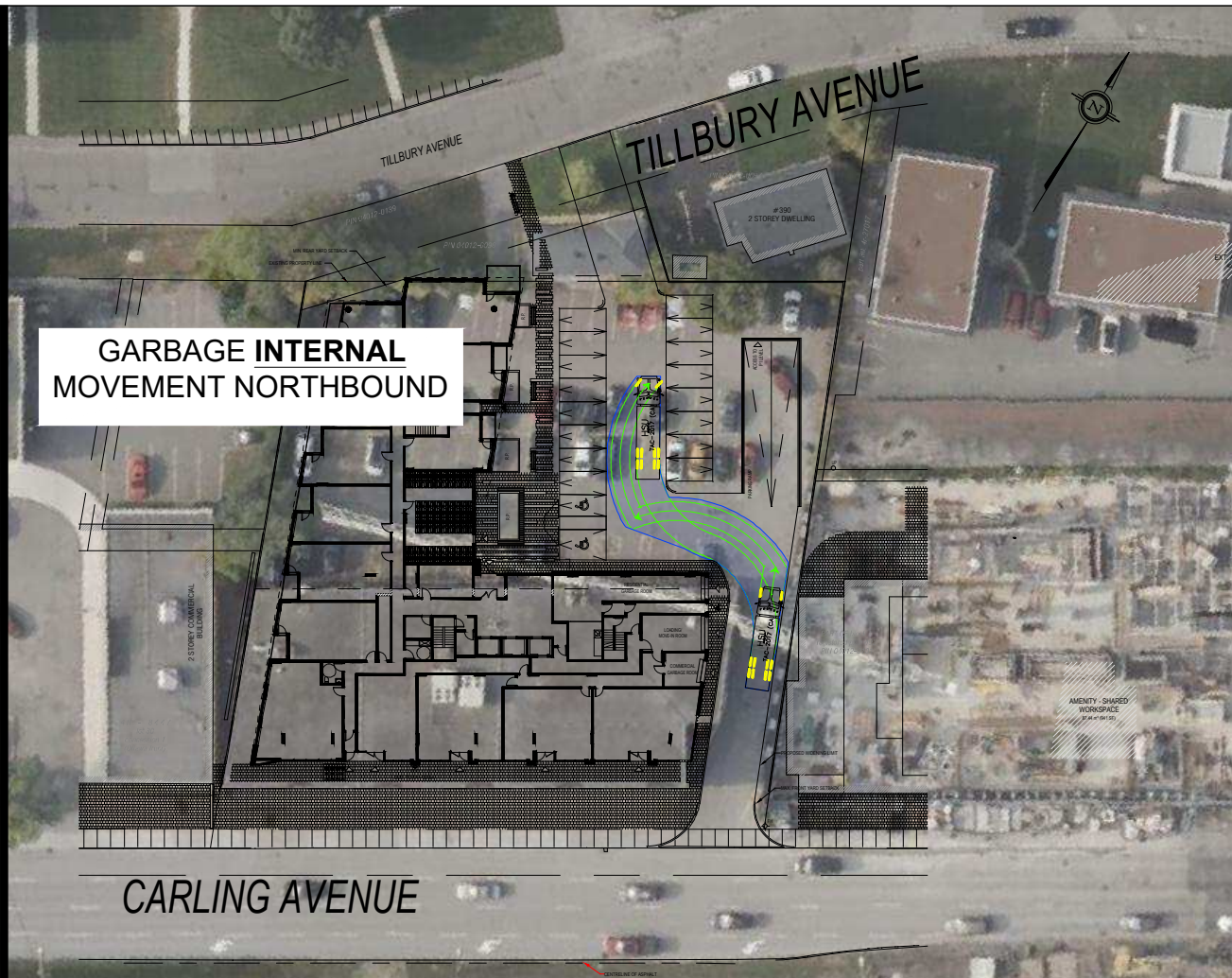
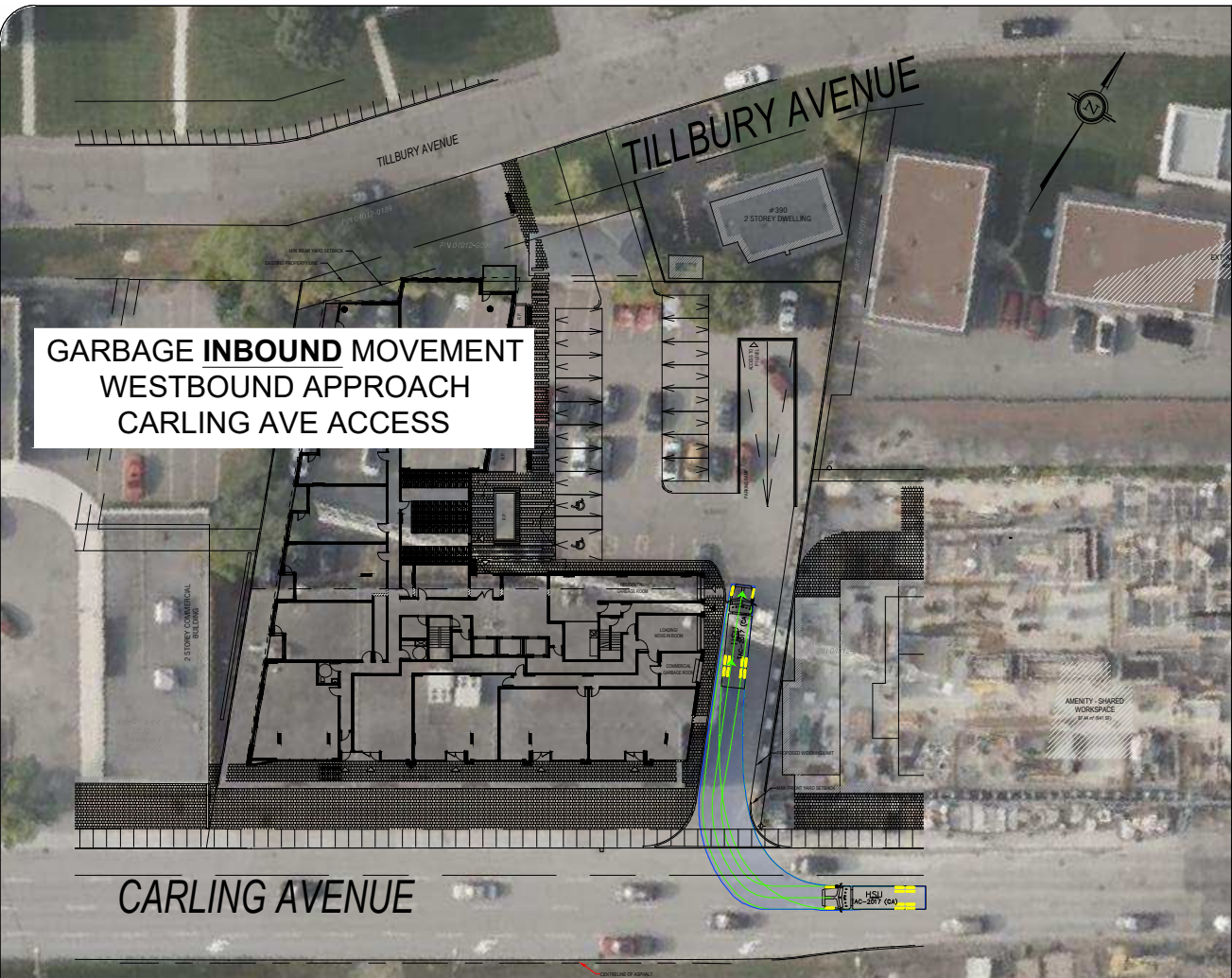

Notes:

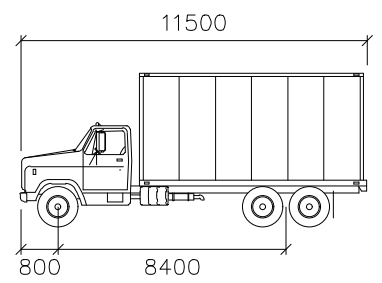

HSU
 mm
 Width : 2600
 Track : 2600
 Lock to Lock Time : 6.0
 Steering Angle : 40.0

04	Issued for Review	AN	2024-06-20
REV:	DESCRIPTION:	BY:	DATE:
STATUS:			

CGH Transportation
 6 Plaza Court
 Ottawa, ON
 K2H 7W1
 (343) 999-9117

CLIENT: **Insdie Edge Properties**
 464 Bank Street, Suite 200
 Ottawa, ON
 K2P 1Z3

ARCHITECT:

SITE: **1675-1673 Carling Ave /
 386 Tilbury**

TITLE: **Garbage Turning Movements
 Carling Avenue Access**

SCALE AT A3: NTS	DATE: 2024-06-20	DRAWN: AN	CHECKED: AH
PROJECT NO: 2023-083	DRAWING NO: 001	REVISION: 04	

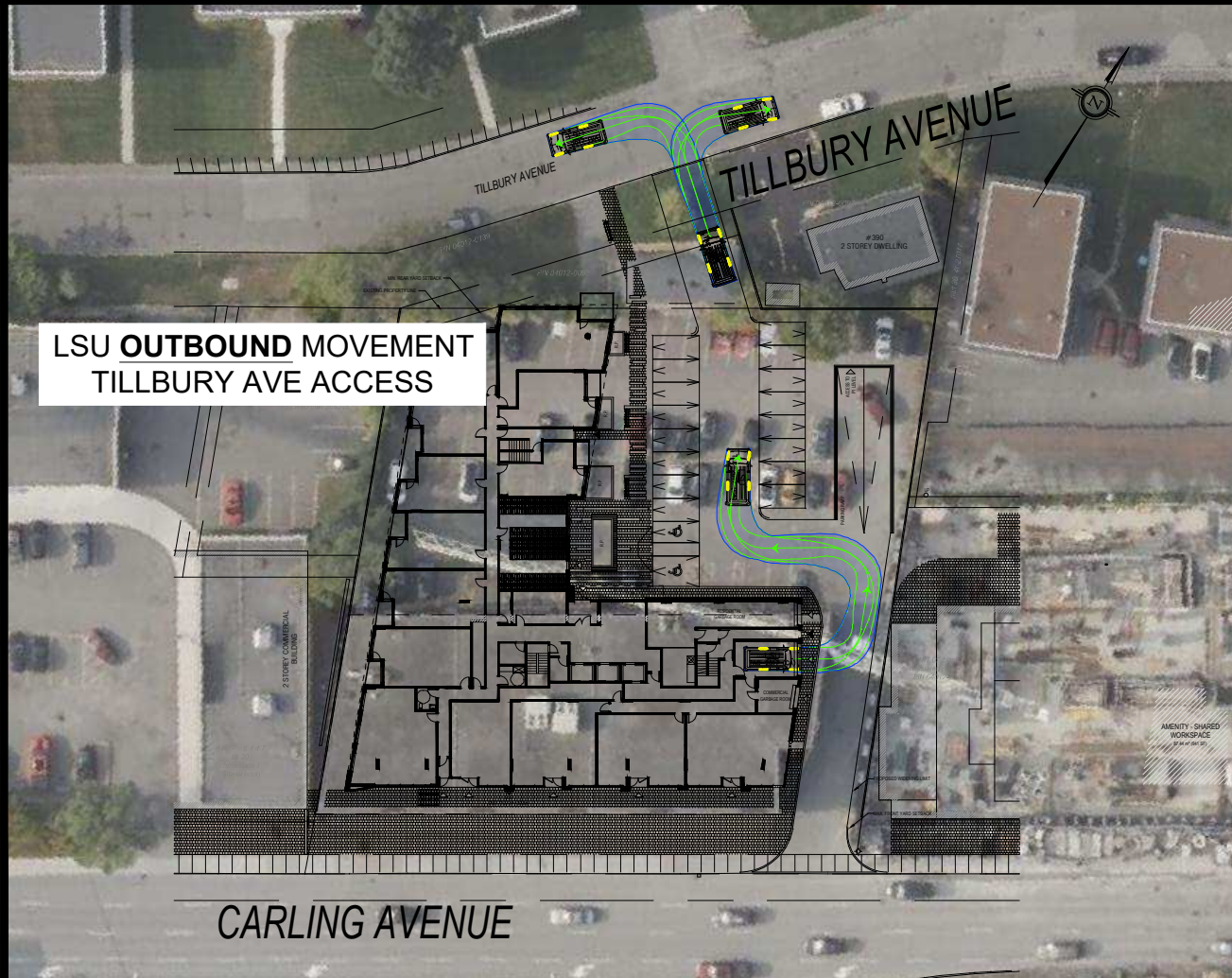
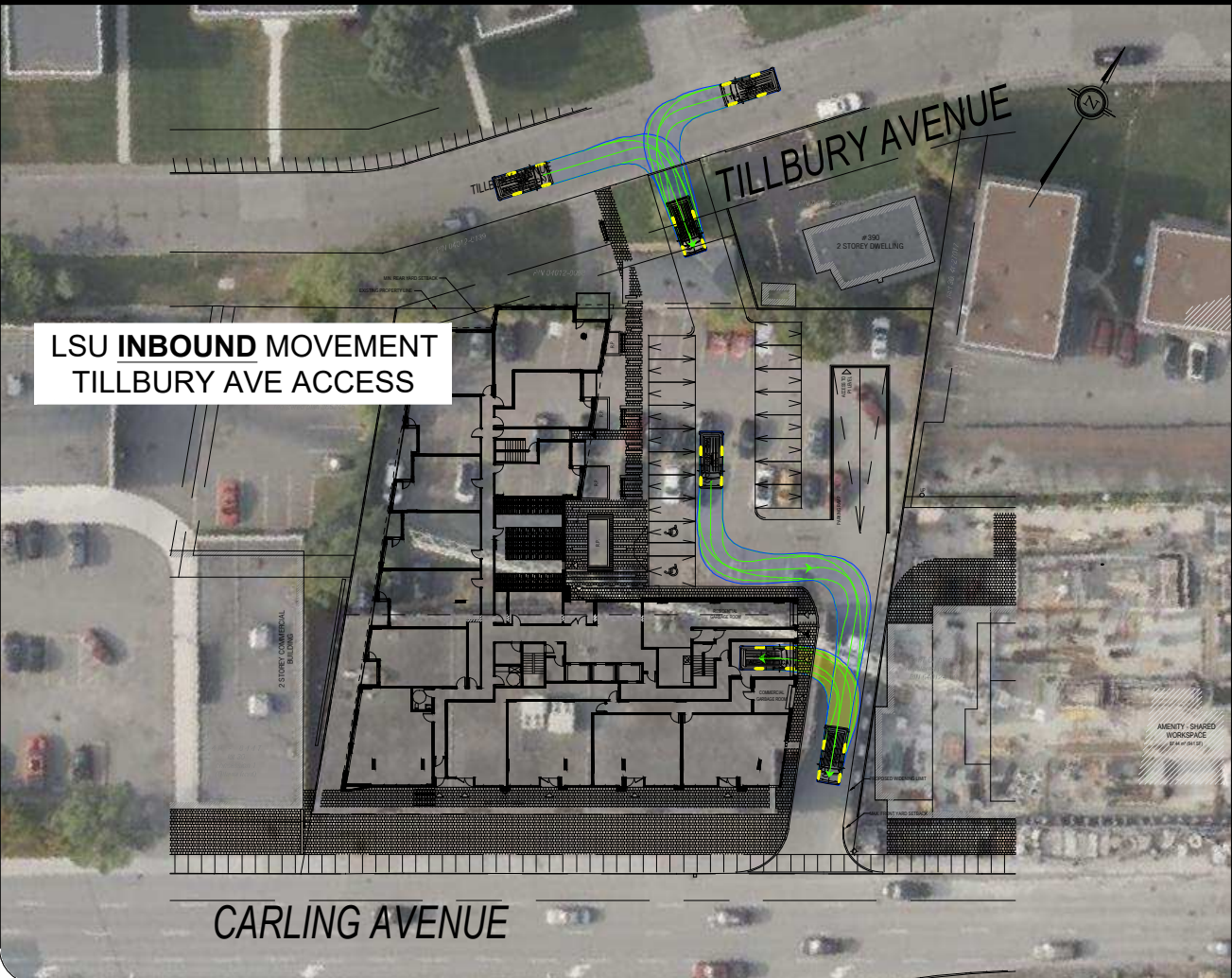
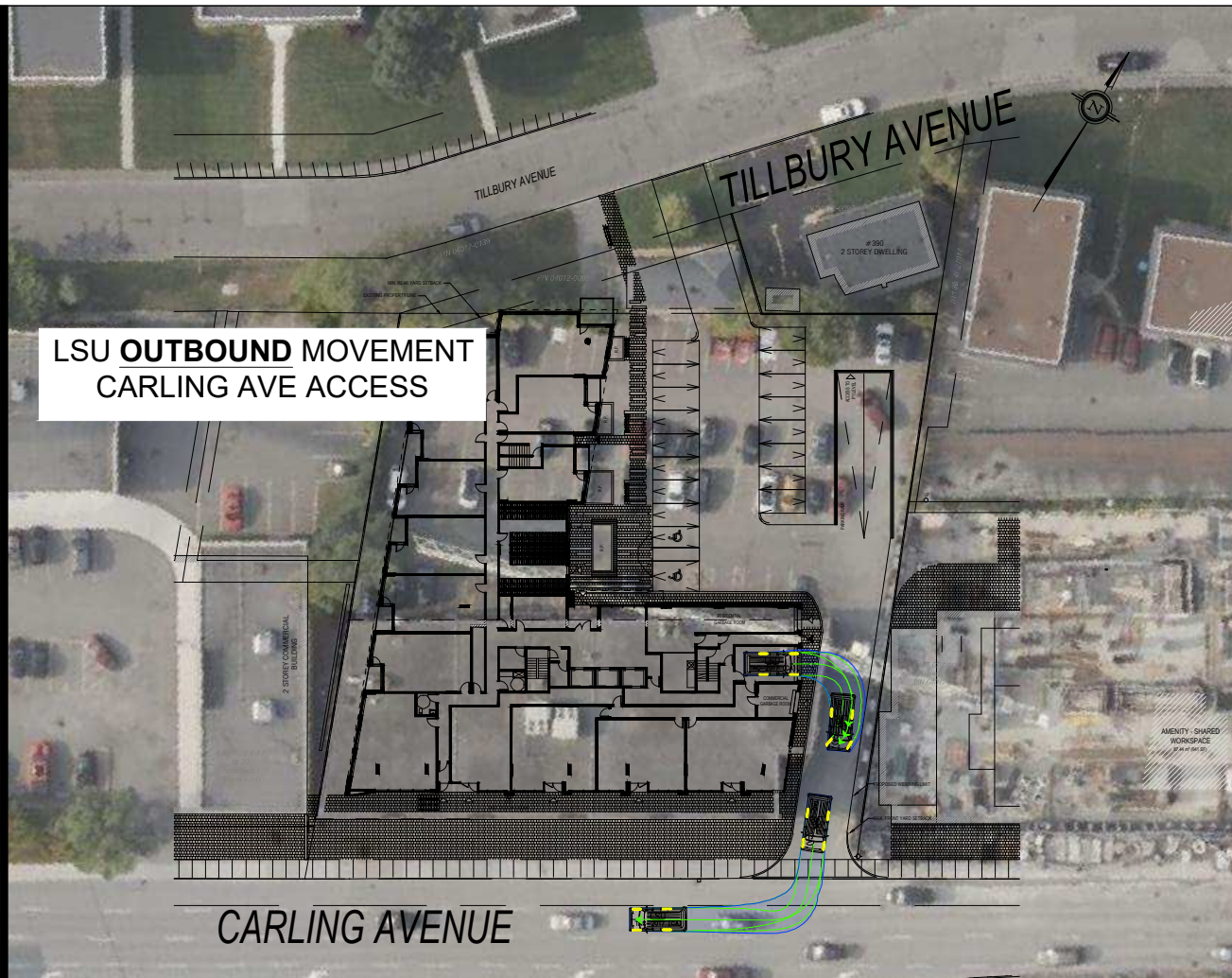
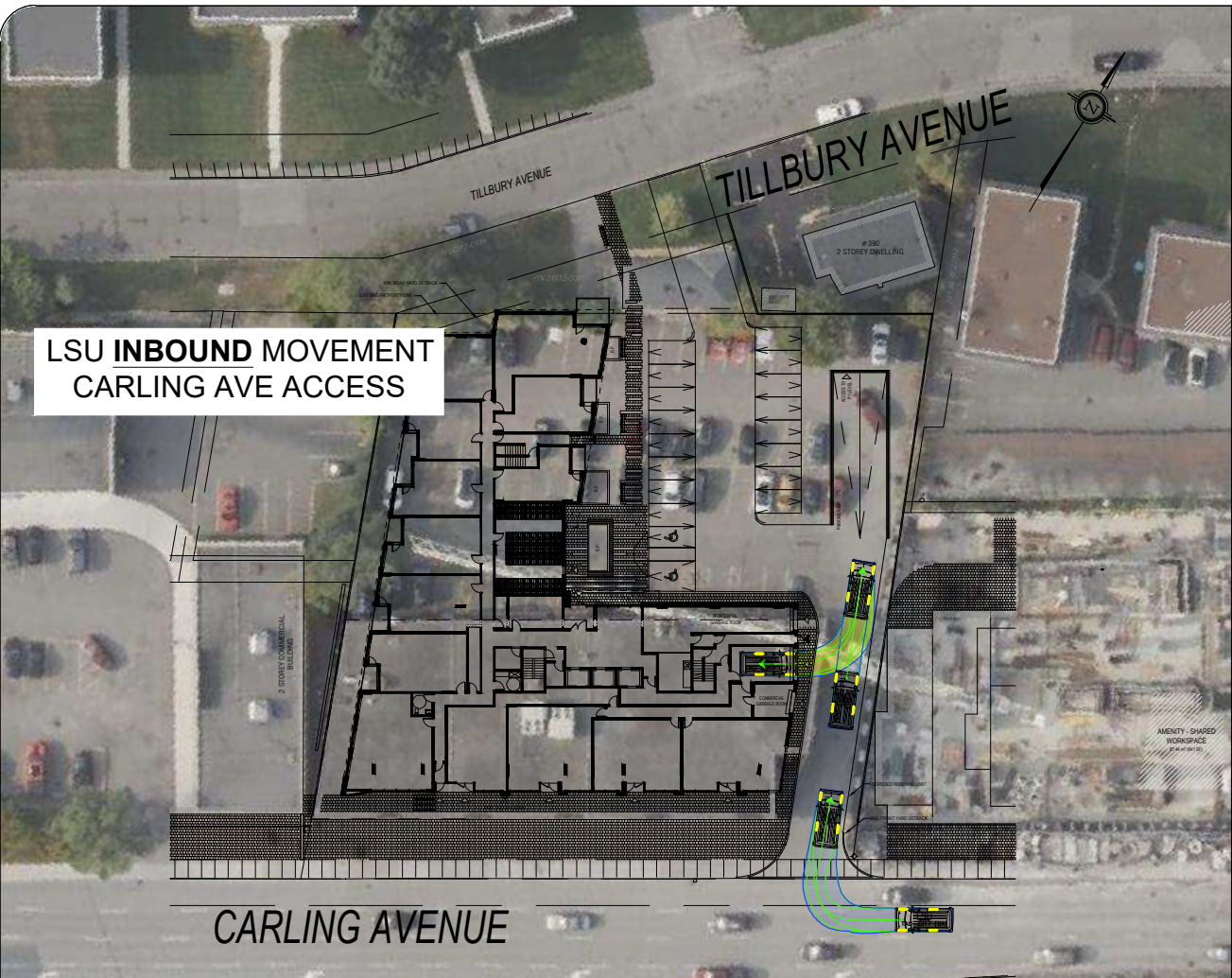

Notes:

LSU
 Width : 2600 mm
 Track : 2600
 Lock to Lock Time : 6.0
 Steering Angle : 40.3

04	Issued for Review	AN	2024-06-20
REV:	DESCRIPTION:	BY:	DATE:
STATUS:			

CGH Transportation
 6 Plaza Court
 Ottawa, ON
 K2H 7W1
 (343) 999-9117

CLIENT: Inside Edge Properties
 464 Bank Street, Suite 200
 Ottawa, ON
 K2P 1Z3

ARCHITECT:

SITE: 1675-1673 Carling Ave /
 386 Tilbury

TITLE: Garbage Turning Movements
 Carling Avenue Access

SCALE AT A3: NTS	DATE: 2024-06-20	DRAWN: AN	CHECKED: AH
PROJECT NO: 2023-083	DRAWING NO: 002	REVISION: 04	

Appendix H

MMLOS Analysis

Multi-Modal Level of Service - Segments Form

Consultant	CGH Transportation Inc
Scenario	Existing/Future
Comments	

Project	2023-083
Date	8/17/2023

SEGMENTS			Carling	Carling	Tillbury
			Existing	Future	Existing/Future
Pedestrian	Sidewalk Width	-	≥ 2 m	≥ 2 m	1.8 m
	Boulevard Width		< 0.5	< 0.5	< 0.5 m
	Avg Daily Curb Lane Traffic Volume		≤ 3000	≤ 3000	≤ 3000
	Operating Speed		> 60 km/h	> 60 km/h	> 30 to 50 km/h
	On-Street Parking		no	no	yes
	Exposure to Traffic PLoS		D	D	B
	Effective Sidewalk Width				
Pedestrian Volume					
Crowding PLoS	-	-	-		
Level of Service	-	-	-		
Bicycle	Type of Cycling Facility	F	Mixed Traffic	Curbside Bike Lane	Mixed Traffic
	Number of Travel Lanes		≥ 6 lanes total	≥ 3 each direction	≤ 2 (no centreline)
	Operating Speed		≥ 60 km/h	>50 to 70 km/h	≤ 40 km/h
	# of Lanes & Operating Speed LoS		F	D	A
	Bike Lane (+ Parking Lane) Width				
	Bike Lane Width LoS		-	-	-
	Bike Lane Blockages				
	Blockage LoS		-	-	-
	Median Refuge Width (no median = < 1.8 m)		< 1.8 m refuge	< 1.8 m refuge	< 1.8 m refuge
	No. of Lanes at Unsignalized Crossing		≤ 3 lanes	≤ 3 lanes	≤ 3 lanes
Sidestreet Operating Speed	>60 to <65 km/h	>60 to <65 km/h	≤ 40 km/h		
Unsignalized Crossing - Lowest LoS	D	C	A		
Level of Service	F	D	A		
Transit	Facility Type	D	Mixed Traffic	Bus lane	
	Friction or Ratio Transit:Posted Speed		Vt/Vp ≥ 0.8	Cf ≤ 60	
	Level of Service		D	B	-
Truck	Truck Lane Width	A	≤ 3.5 m	≤ 3.5 m	
	Travel Lanes per Direction		> 1	> 1	
	Level of Service		A	A	-