

SITE BENCHMARK
MAG NAIL IN UP
EL.=122.77m

STITTSVILLE MAIN STREET
(MTO PLAN P-1969-38, INST. (B)4379)
PIN 04449 - 0360

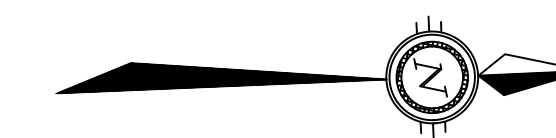
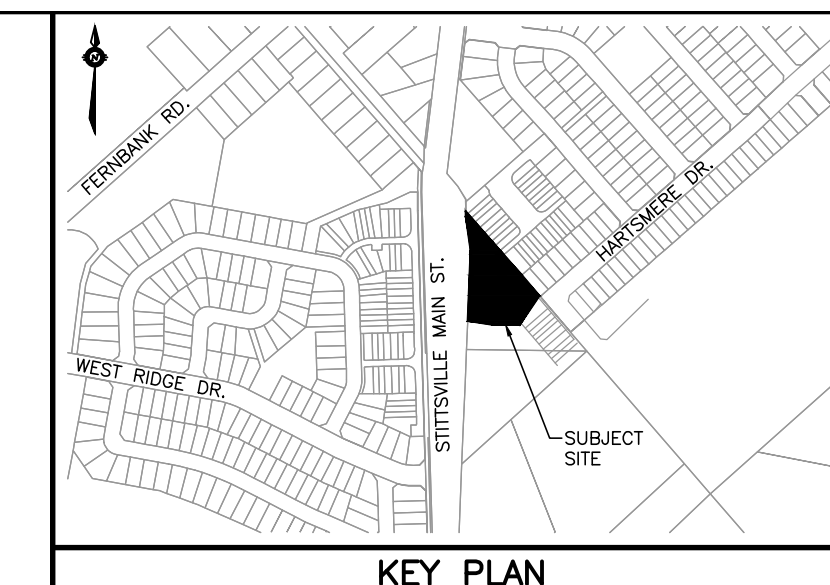

LEGEND

- PROPERTY BOUNDARY
- - - EASEMENT
- ⊙ EXISTING HYDRANT
- ⊕ EXISTING VALVE & VALVE BOX
- EXISTING WATERMAIN
- EXISTING SANITARY SEWER & MANHOLE
- EXISTING STORM SEWER & MANHOLE
- EXISTING CATCH BASIN
- ⊙ HYDRANT
- CURB STOP & SERVICE POST
- WATERMAIN
- SANITARY SEWER & MANHOLE
- STORM SEWER & MANHOLE
- ⊕ CATCH BASIN MANHOLE
- CATCH BASIN

STORM MANHOLE TABLE				
MANHOLE No.	STRUCTURE	T/G ELEV	INVERT	COVER TYPE
203	1200mm	119.00	SE=117.42 NW=117.45	S28.1
EX 266	1200mm	119.11	W=117.00	S24.1
204	1200mm	119.30	E=117.23 NW=117.36	S24.1
202	1200mm	121.19	SE=118.62	S24.1

SANITARY MANHOLE TABLE				
MANHOLE No.	STRUCTURE	T/G ELEV	INVERT	COVER TYPE
EX 267	1200mm	119.14	W=116.41	S24
103	1200mm	119.15	E=116.54 NW=116.60	S24
102	1200mm	120.91	SE=118.39	S24

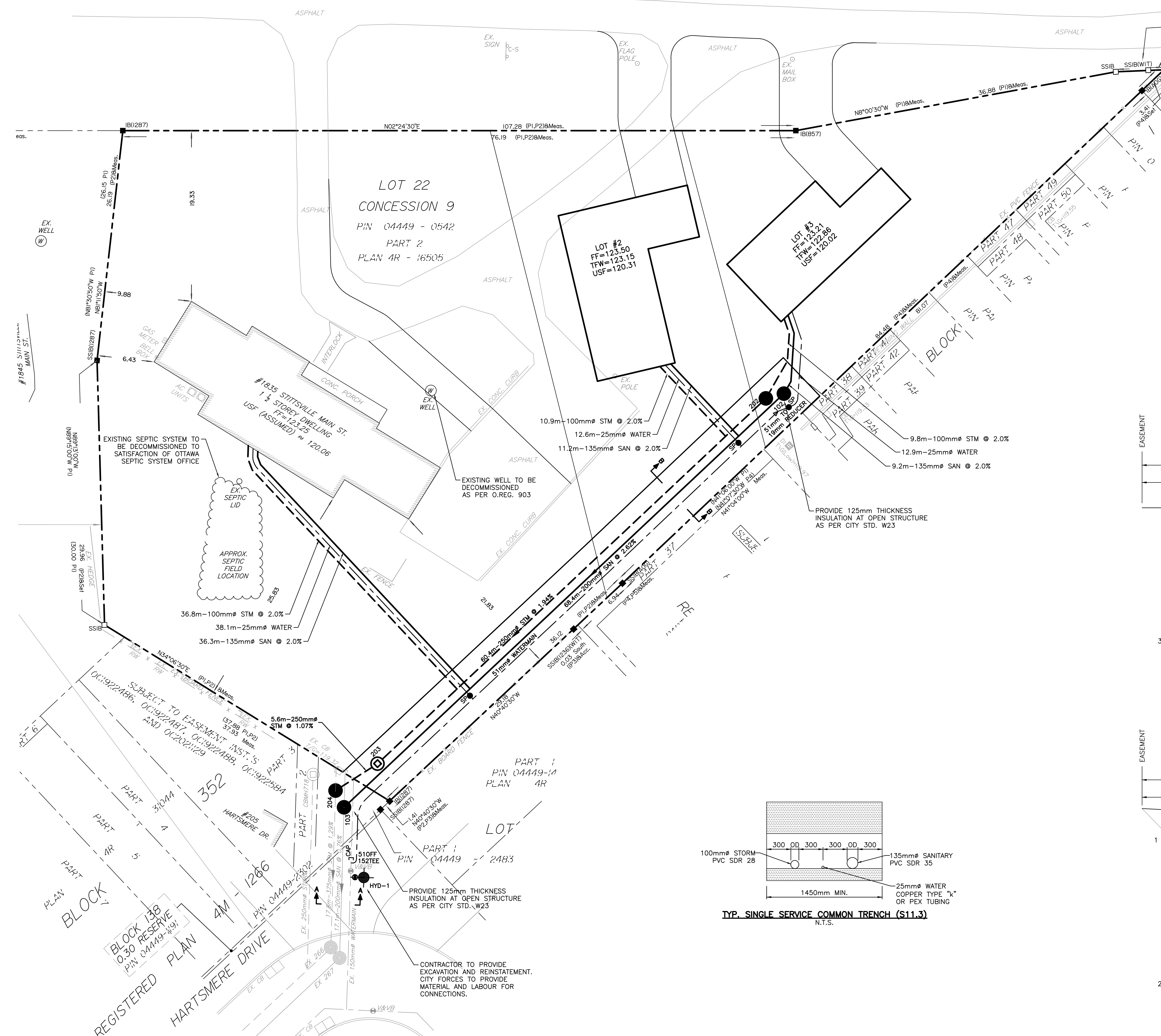
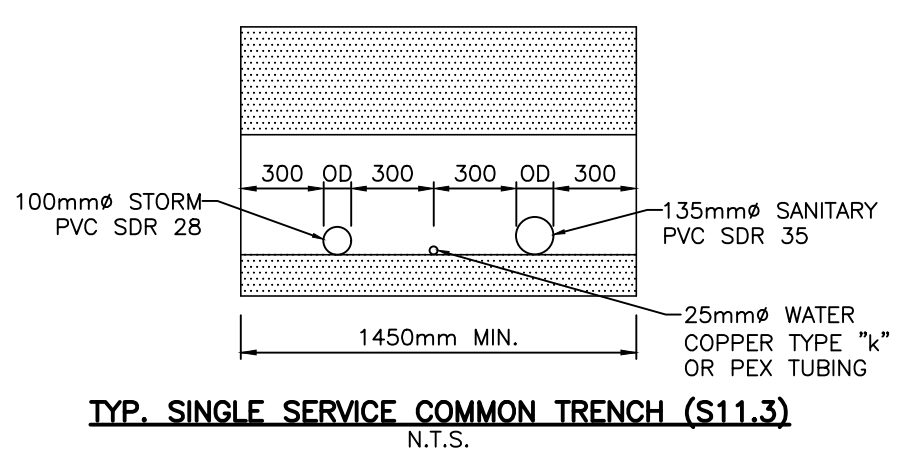
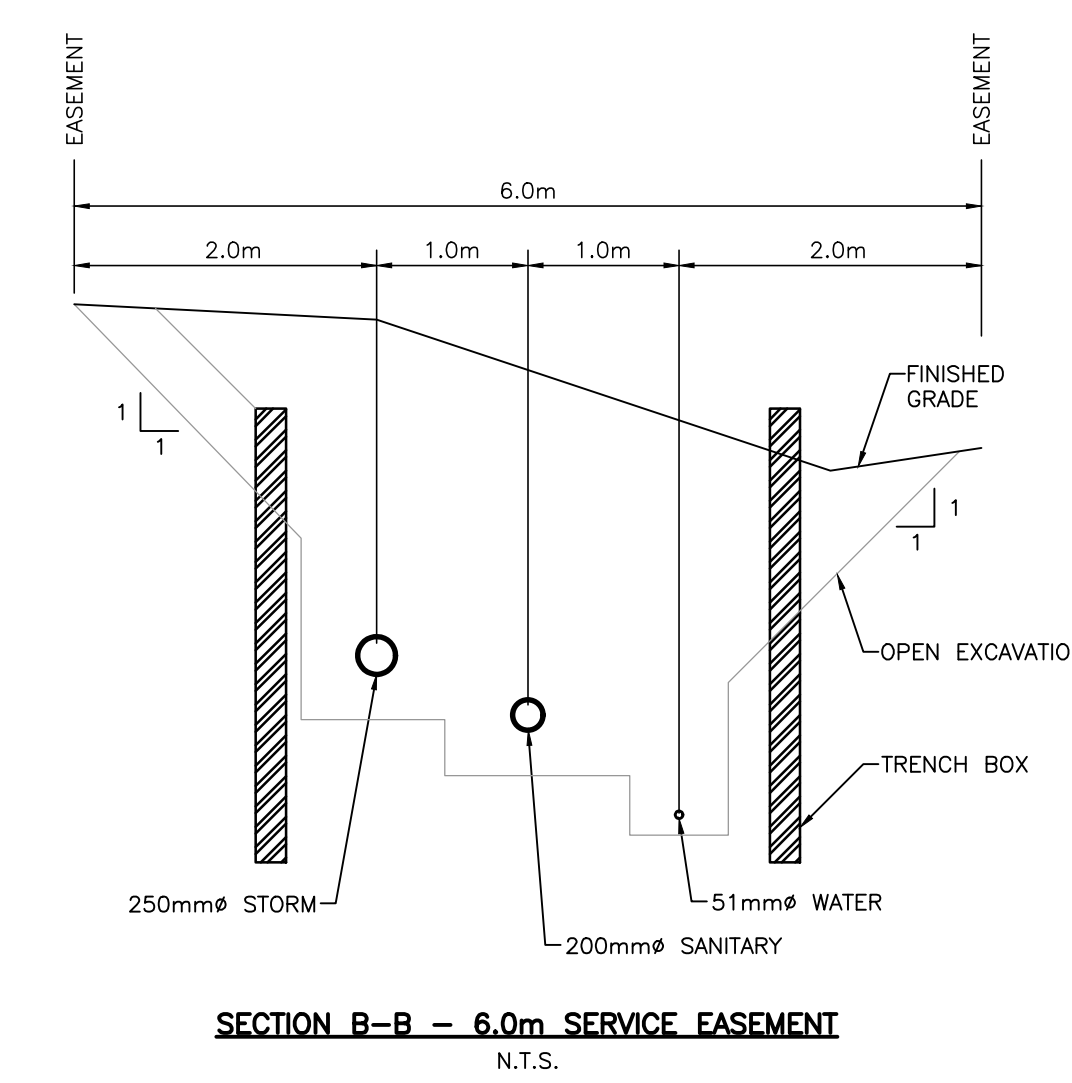
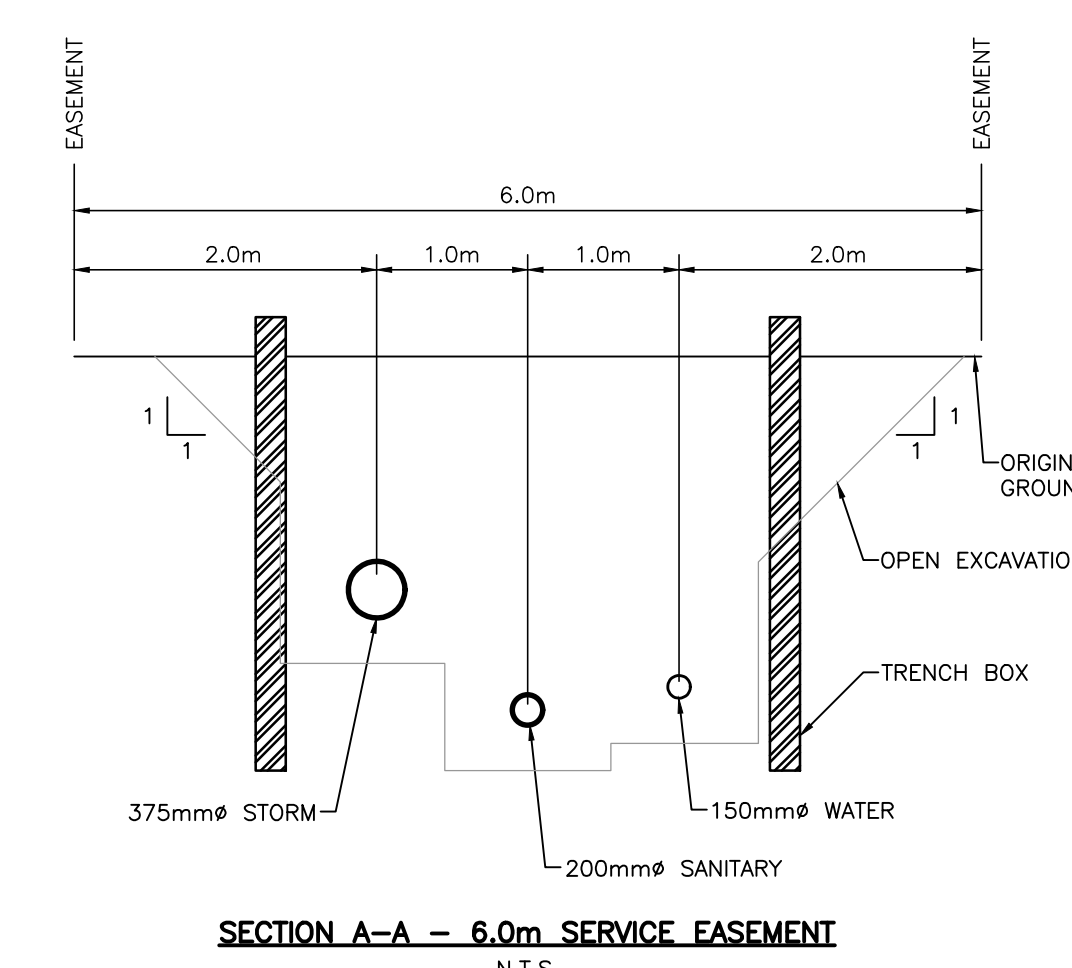

NOTES

THE POSITION OF ALL POLE LINES, CONDUITS, WATERMANS, SEWERS AND OTHER UNDERGROUND AND OVERGROUND UTILITIES AND STRUCTURES IS NOT NECESSARILY SHOWN ON THE CONTRACT DRAWINGS, AND WHERE SHOWN, THE ACCURACY OF THE POSITION OF SUCH UTILITIES AND STRUCTURES IS NOT GUARANTEED. BEFORE STARTING WORK, DETERMINE THE EXACT LOCATION OF ALL SUCH UTILITIES AND STRUCTURES AND ASSUME ALL LIABILITY FOR DAMAGE TO THEM.

NO.	REVISION DESCRIPTION	DATE	BY
2	REVISED PER COMMENTS	07/06/22	AHJ
1	ISSUED FOR ZONING BY-LAW AMENDMENT	10/02/22	AHJ

SCALE	
HORIZONTAL 1:250	

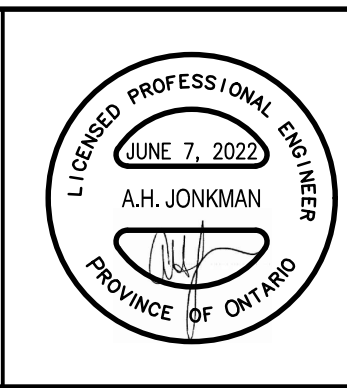
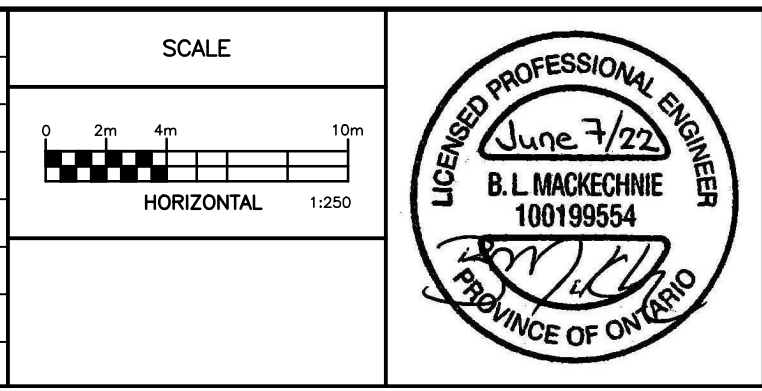

Robinson
Land Development

350 Palladium Drive
Ottawa, ON K2V 1A8
(613) 592-6060 roii.com

DESIGN	BLM
CHECKED	AHJ
DRAWN	BLM
CHECKED	AHJ
APPROVED	AHJ

JENNIFER McGAHAN
WIRE INVESTMENT CORP.

1835 STITTSVILLE MAIN STREET
STITTSVILLE, ON

NOT FOR CONSTRUCTION	
PROJECT No.	22008
SURVEY	AOV
DATED	JUNE 2022
DWG. No.	22008-S1