

TREES:

	NAME	QTY.	MATURE SPREAD (m)	MATURE HEIGHT (m)
	PRAIRIE SKYRISE ASPEN (POPULUS TREMULOIDES)	1	0.06	2
	COLUMNAR BLUE SPRUCE (PICEA PUNGENS 'FASTIGIATA')	4	1.83	3.05
TOTAL 5 TREES				

SHRUBS:

	NAME	QTY.	MATURE SPREAD	MATURE HEIGHT
	DWARF KOREAN LILAC (SYRINGA MEYERI 'PALIBIN')	5	5'	5'
	GOLDMOUND SPIREA (SPIRAEA JAPONICA 'GOLDMOUND')	3	2'	2'
	MOPS MUGO PINE (PINUS MUGO 'MOPS')	4	2'-6"	2'
	CALGARY CARPET JUNIPER (JUNIPERUS SABINA 'CALGARY CARPET')	3	4'	1'
TOTAL 15 SHRUBS				

PLANT NOTE:
 - PLANTING BEDS TO BE INSTALLED WITH 100MM DEEP WOOD MULCH WITH 450 MM PLANTING SOIL
 - PLANT MATERIAL SHOWN AT MATURE SPREAD
 DECIDUOUS TREES MUST HAVE A MINIMUM CALIPER OF 60 MM.
 CONIFEROUS TREES MUST HAVE A MINIMUM HEIGHT OF 2.0 M.
 DECIDUOUS SHRUBS MUST HAVE A MINIMUM SPREAD OF 600MM
 CONIFEROUS SHRUBS MUST HAVE A MINIMUM SPREAD OF 600 MM

REQUIRED PLANTINGS
 A minimum of 1.0 tree & 3.0 shrubs must be provided for each 110 m² of parcel area
 Lot area = 544.5 m² / 110 = 5.0
 Trees - 1.0 x 5.0 = 5.0
 Shrubs - 3.0 x 5.0 = 15.0
 Proposed
 Trees - 5
 Shrubs - 15

LANDSCAPE AREA: 229.8 M² (2472.3 SF)

SOFT LANDSCAPING:	1485.6 SQ.FT. (138.0 SQM)
PRIVATE AMENITY AREA:	12.0 SQ.M. (130.0 SQ.FT.)
COMMON AMENITY AREA:	6.7 SQ.M. (72.0 SQ.FT.)
AMENITY AREA TOTAL:	18.7 SQ.M. (202.0 SQ.FT.)
CONCRETE:	98.2 SQM (960.0 SQ.FT.)
NEW SOD:	57.7 SQM (620.9 SQ.FT.)
MULCH:	61.6 SQM (662.7 SQ.FT.)
SOFT LANDSCAPING TOTAL:	138.0 SQM (1485.6 SQ.FT.)
IRRIGATION SYSTEM:	UNDERGROUND IRRIGATION SYSTEM

TOTAL GROSS FLOOR AREA 519.31m² (5587.0 SQFT)

TOTAL = 519.31 m² (5587.0 sqft)

Unit A Total = 99.41 m² (1388.5 sqft)

Main floor = 53.12 m² (571.5 sqft)

Upper floor = 46.30 m² (498.0 sqft)

Third floor = 29.65 m² (319.0 sqft)

Unit B Total = 99.41 m² (1388.5 sqft)

Main floor = 53.12 m² (571.5 sqft)

Upper floor = 46.30 m² (498.0 sqft)

Third floor = 29.65 m² (319.0 sqft)

Unit C Total = 99.41 m² (1405.0 sqft)

Main floor = 53.12 m² (571.5 sqft)

Upper floor = 46.30 m² (498.0 sqft)

Third floor = 29.65 m² (319.0 sqft)

Unit D Total = 99.41 m² (1405.0 sqft)

Main floor = 53.12 m² (571.5 sqft)

Upper floor = 46.30 m² (498.0 sqft)

Third floor = 31.2 m² (335.5 sqft)

SUITE FLOOR AREA 151.0 m²

TOTAL = 151.0 m² (1624.0 sf)

Suite A1 = 37.5 m² (403.0 sqft)

Suite B1 = 37.5 m² (403.0 sqft)

Suite C1 = 38.0 m² (409.0 sqft)

Suite D1 = 38.0 m² (409.5 sqft)

PARCEL COVERAGE 55.7 %

Lot area = 544.5 m² (5858.4 sqft)

Building footprint = 212.5 m² (2286.0 sqft)

Garage footprint = 79.66 m² (857.0 sqft)

Mobility Storage Lockers (x2) = 7.53 m² (81.0 sqft)

Class 1 Bike Lockers (x1) = 3.8 m² (40.5 sqft)

Total coverage area = 303.4 m² (3264.5 sqft)

Total allowed coverage area = 326.7 m² (3515.0 sqft)

SITE PLAN
SCALE: 1:75

LEGEND

	NEW SOD		PROPERTY LINE		SANITARY LINE		POWER POLES
	CONCRETE		SETBACK LINE		WATERLINE		LAMP STANDARDS
	MULCH		BLACK POLYEDGING		STORMLINE		
			NEW WOOD FENCE		OVERHEAD ELECTRICAL LINES		
			WOOD SCREEN				

NOTE:
 • SURVEYOR TO VERIFY DIMENSIONS
 • DO NOT SCALE DRAWING

GENERAL NOTE
 THE CONTRACTOR IS RESPONSIBLE FOR ANY ERRORS OR OMISSIONS TO THE DESIGNER PRIOR TO CONSTRUCTION.
 DRAWINGS ARE NOT TO BE SCALED FOR MEASUREMENTS.
 ALL DIMENSIONS SHALL BE VERIFIED BY CONTRACTOR
 ALL DISCREPANCIES SHOULD BE REPORTED TO THE ENGINEER PRIOR TO COMMENCEMENT OF THE WORK.

	ISSUED FOR REVIEW	AV	W	02/03/26
	ISSUED FOR REVIEW	AV	W	16/02/26
	ISSUED FOR REVIEW	AV	W	27/01/26
	ISSUED FOR REVIEW	AV	W	06/12/25
	ISSUED FOR REVIEW	AV	W	04/12/25
	ISSUED FOR REVIEW	AV	W	02/12/25
REV NO.	REVISION/ISSUE	BY	CHK'D	DD/MM/YY

PROJECT:
3939 19th AVENUE S.W.
 LOT 19, BLOCK 11
 PLAN 8429GQ
 CALGARY, ALBERTA

JAYA
 DESIGN AND DRAFTING
 PO BOX 30010 Regina, Sk S4N 7K9
 Email: vetovarma@gmail.com

SHEET TITLE	SITE PLAN	
DRAWN:	AV NOV. 25, 2025	DWG NO:
CHECKED:	WV NOV. 25, 2025	
APPROVED:	WV NOV. 25, 2025	
JOB#:		
SHEET NO:	1 OF 1	

SITE PLAN

DO NOT SCALE THIS DRAWING

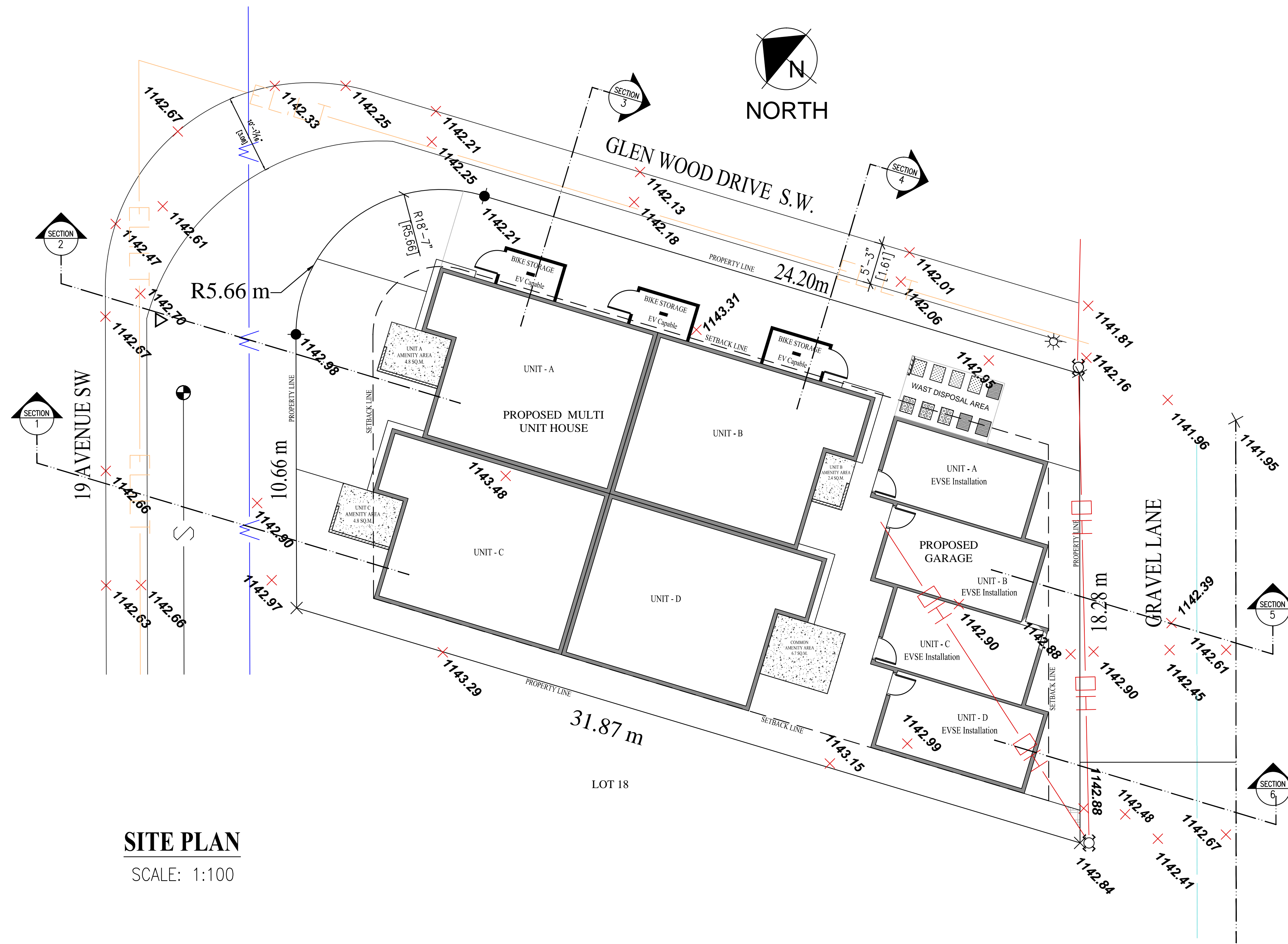

SITE PLAN

SCALE: 1:100

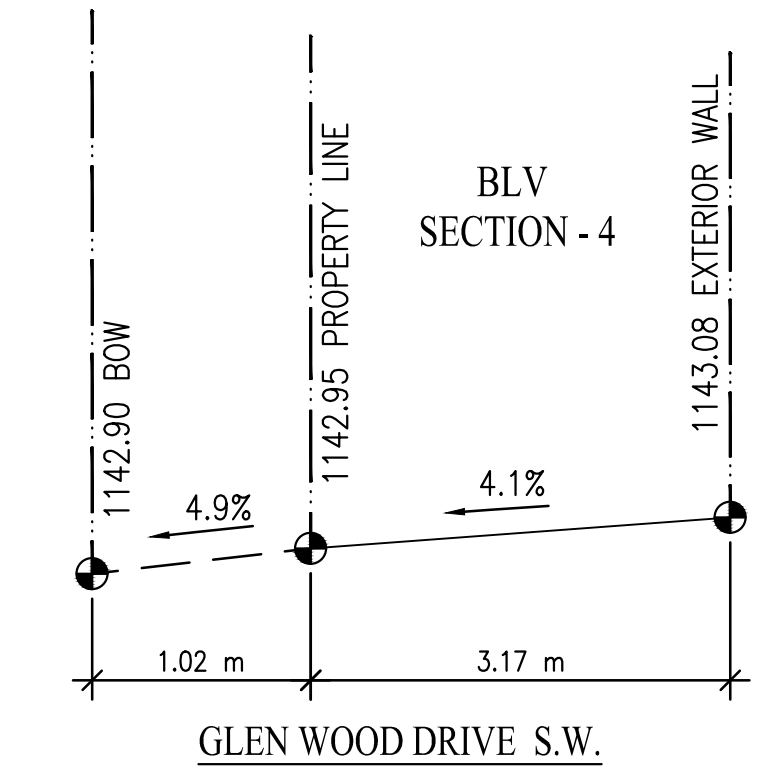
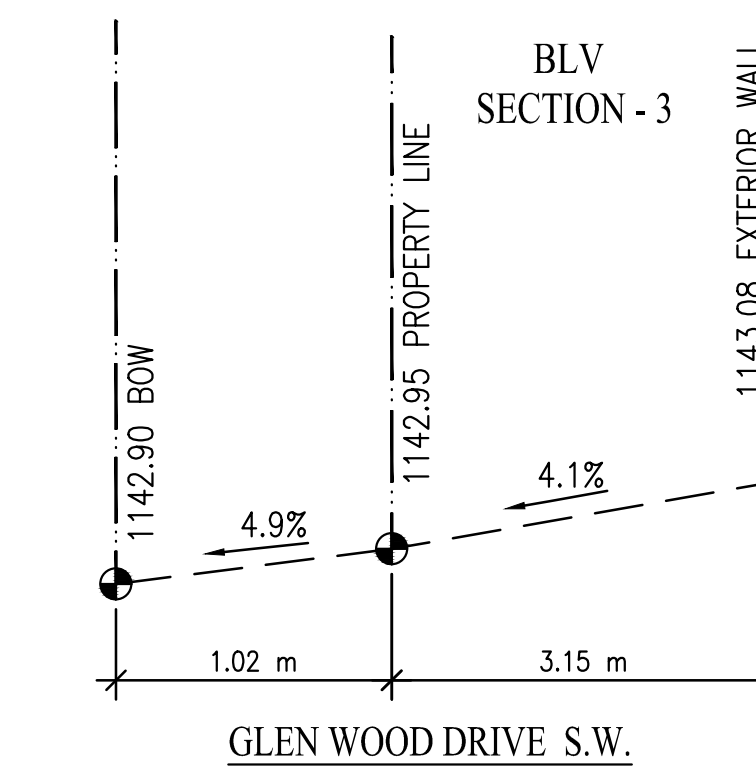
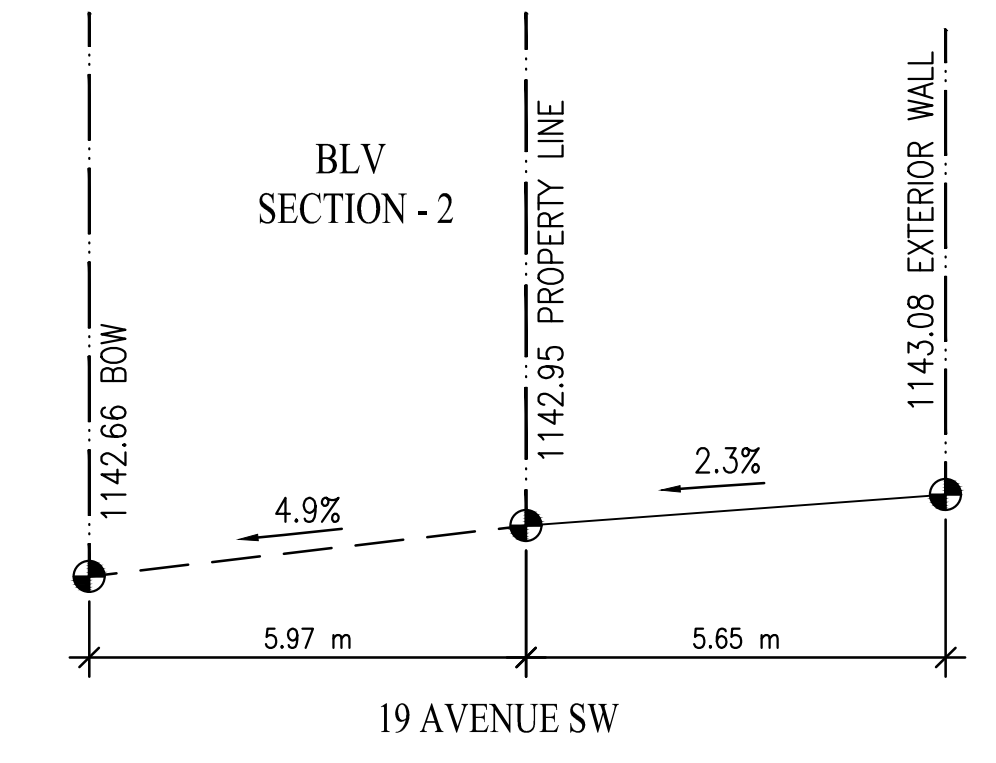
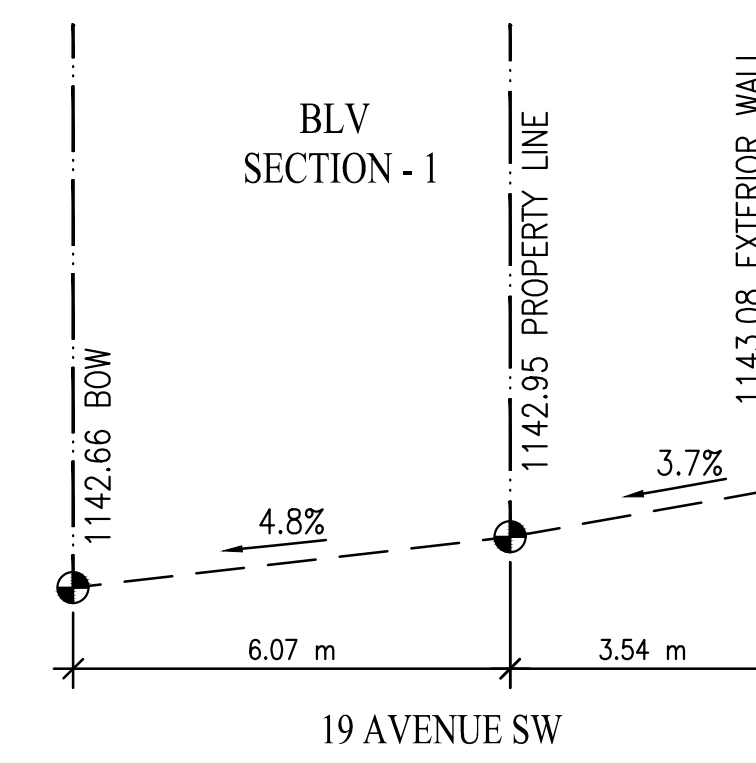

BOULEVARD SECTIONS

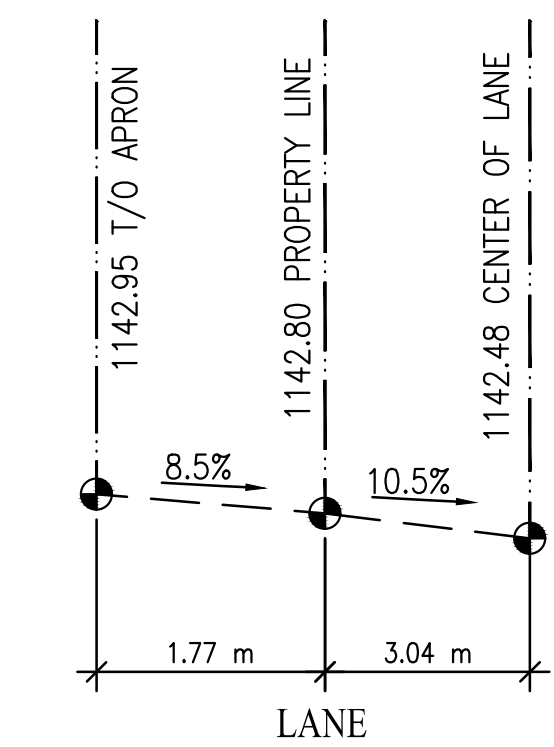
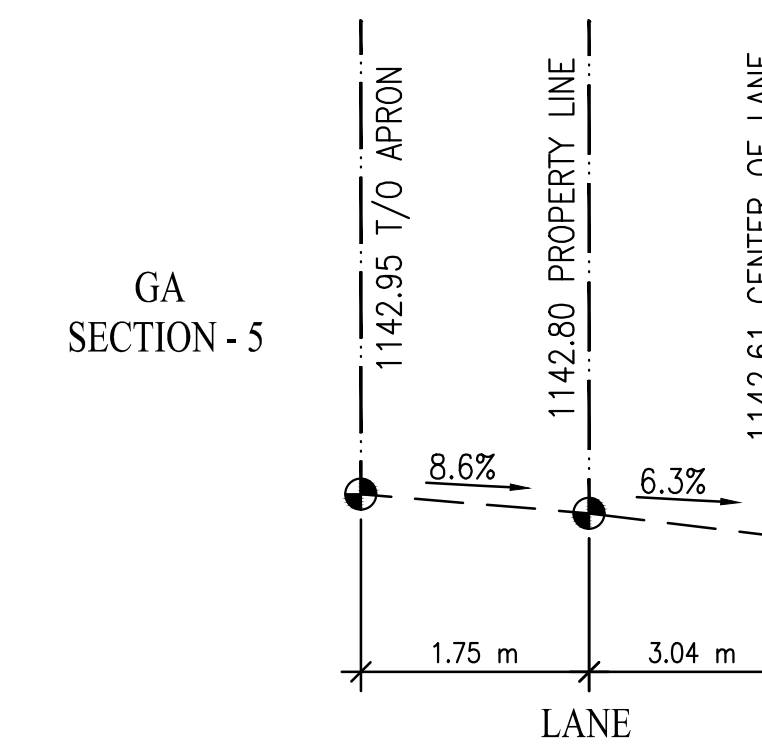

GARAGE APARON SECTIONS

GENERAL NOTE
 THE CONTRACTOR IS RESPONSIBLE FOR ANY ERRORS OR OMISSIONS TO THE DESIGNER PRIOR TO CONSTRUCTION.
 DRAWINGS ARE NOT TO BE SCALED FOR MEASUREMENTS.
 ALL DIMENSIONS SHALL BE VERIFIED BY CONTRACTOR
 ALL DISCREPANCIES SHOULD BE REPORTED TO THE ENGINEER PRIOR TO COMMENCEMENT OF THE WORK.

△	ISSUED FOR REVIEW	AV	W	02/03/26
△	ISSUED FOR REVIEW	AV	W	16/02/26
△	ISSUED FOR REVIEW	AV	W	27/01/26
△	ISSUED FOR REVIEW	AV	W	06/12/25
△	ISSUED FOR REVIEW	AV	W	04/12/25
△	ISSUED FOR REVIEW	AV	W	02/12/25
△	ISSUED FOR REVIEW	AV	W	02/12/25
REV NO.	REVISION/ISSUE	BY	CHK'D	DD/MM/YY

PROJECT:
3939 19th AVENUE S.W.
 LOT 19, BLOCK 11
 PLAN 8429GQ
 CALGARY, ALBERTA

JAYA
 DESIGN AND DRAFTING
 PO BOX 30010 Regina, Sk S4N 7K9
 Email: vetovarma@gmail.com

SHEET TITLE	SITE PLAN	
DRAWN:	AV	NOV. 25, 2025
CHECKED:	WV	NOV. 25, 2025
APPROVED:	WV	NOV. 25, 2025
JOB#:		
SHEET NO:	1 OF 1	

GRADE SECTION
DO NOT SCALE THIS DRAWING



FRONT ELEVATION
NTS



LEFT ELEVATION
NTS

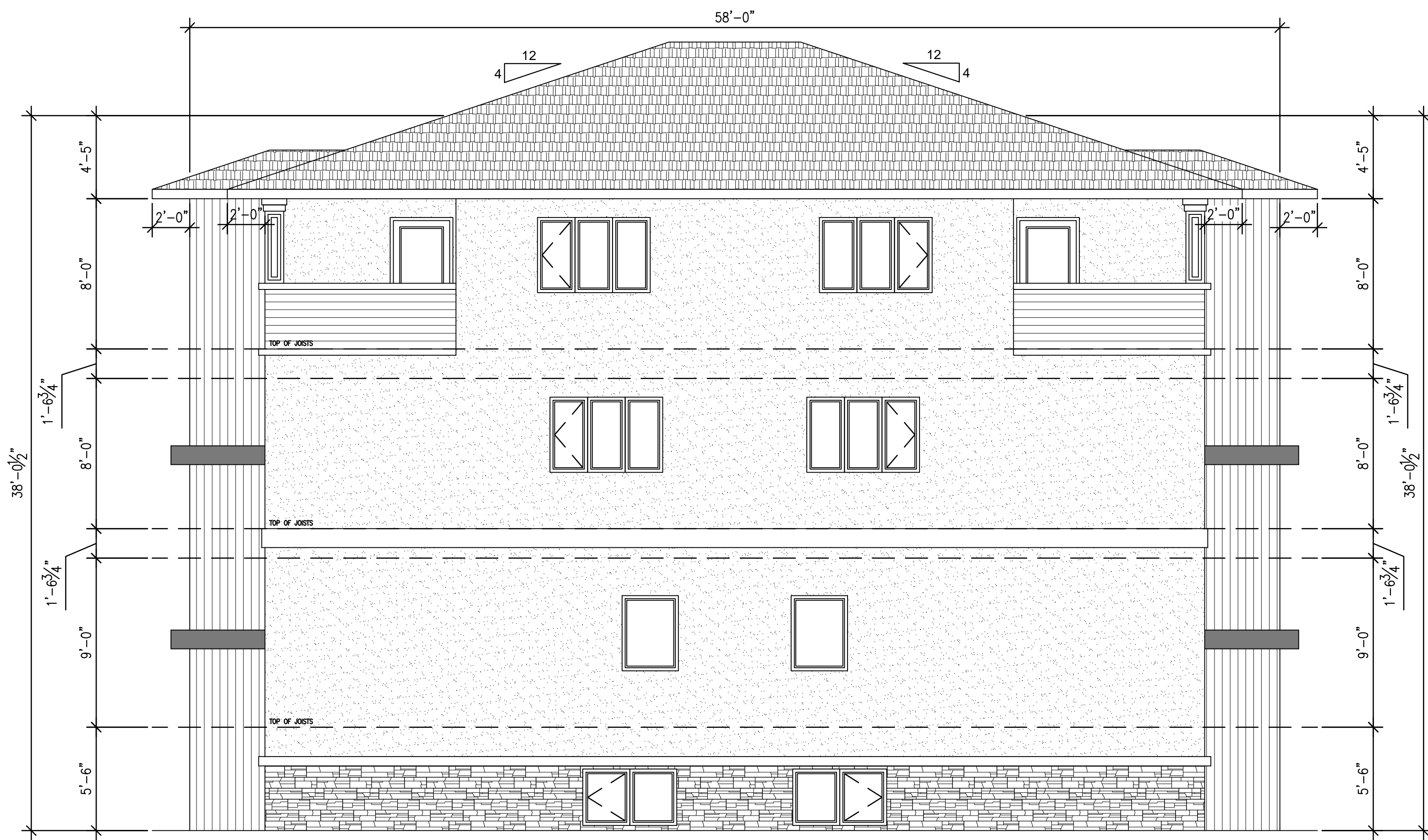

RIGHT ELEVATION
NTS



REAR ELEVATION
NTS

GENERAL NOTE

THE CONTRACTOR IS RESPONSIBLE FOR ANY ERRORS OR OMISSIONS TO THE DESIGNER PRIOR TO CONSTRUCTION.
DRAWINGS ARE NOT TO BE SCALED FOR MEASUREMENTS.
ALL DIMENSIONS SHALL BE VERIFIED BY CONTRACTOR
ALL DISCREPANCIES SHOULD BE REPORTED TO THE ENGINEER PRIOR TO COMMENCEMENT OF THE WORK.

REV NO.	REVISION/ISSUE	BY	CHK'D	DD/MM/YY
1	ISSUED FOR REVIEW	AV	W	02/03/26
2	ISSUED FOR REVIEW	AV	W	16/02/26
3	ISSUED FOR REVIEW	AV	W	27/01/26
4	ISSUED FOR REVIEW	AV	W	06/12/25
5	ISSUED FOR REVIEW	AV	W	04/12/25
6	ISSUED FOR REVIEW	AV	W	02/12/25

PROJECT:

3939 19th AVENUE S.W.
LOT 19, BLOCK 11
PLAN 8429GQ
CALGARY, ALBERTA

JAYA

DESIGN AND DRAFTING
PO BOX 30010 Regina, Sk S4N 7K9
Email: vetovarma@gmail.com

SHEET TITLE	ELEVATIONS	
DRAWN:	AV	NOV. 25, 2025
CHECKED:	WV	NOV. 25, 2025
APPROVED:	WV	NOV. 25, 2025
JOB#:		
SHEET NO:	2 OF 8	

A1.1

DO NOT SCALE THIS DRAWING

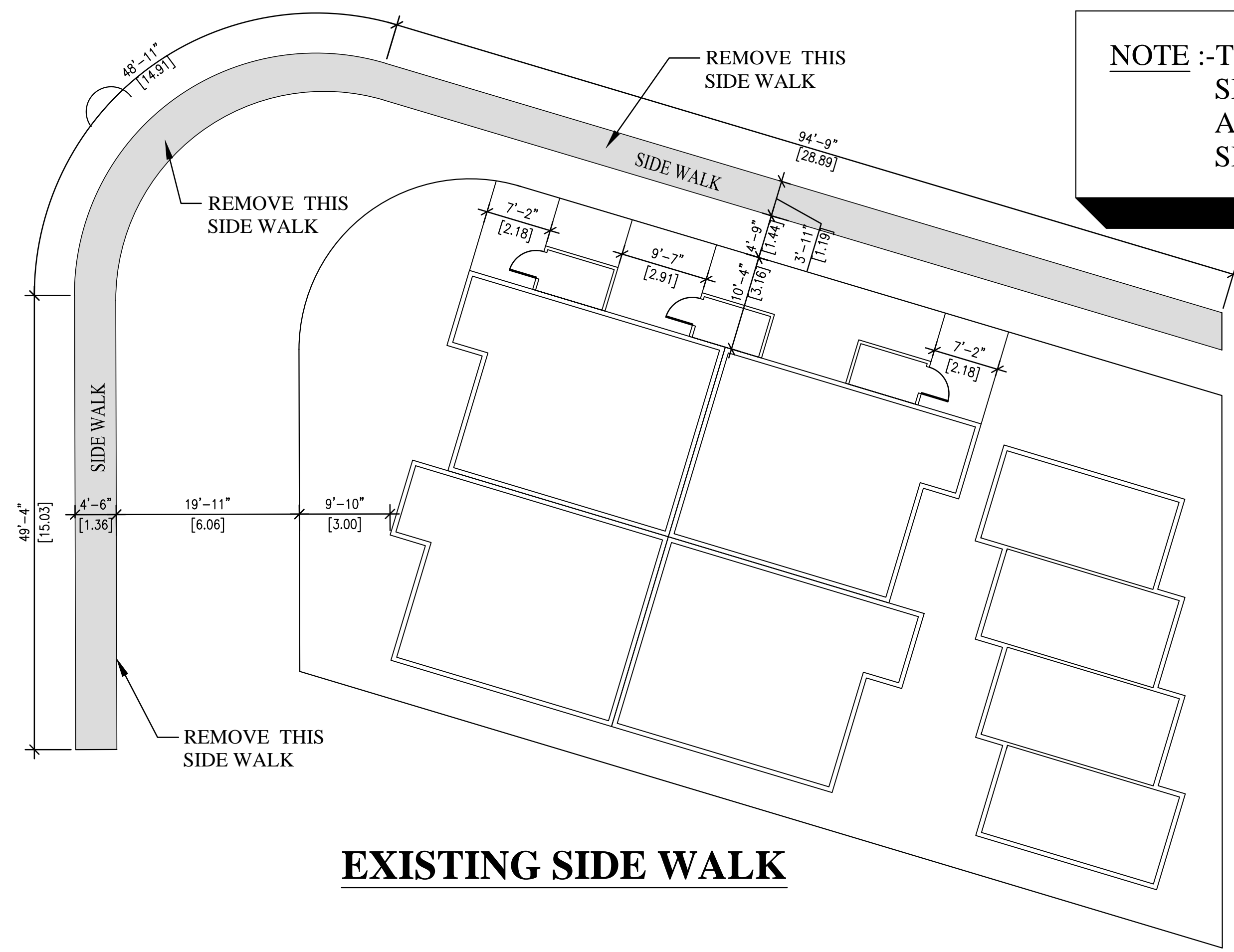

NOTE :-THE WIDTH OF THE EXISTING SIDEWALK IS TO BE REMOVED AND REPLACED WITH A NEW SIDEWALK.

EXISTING SIDE WALK

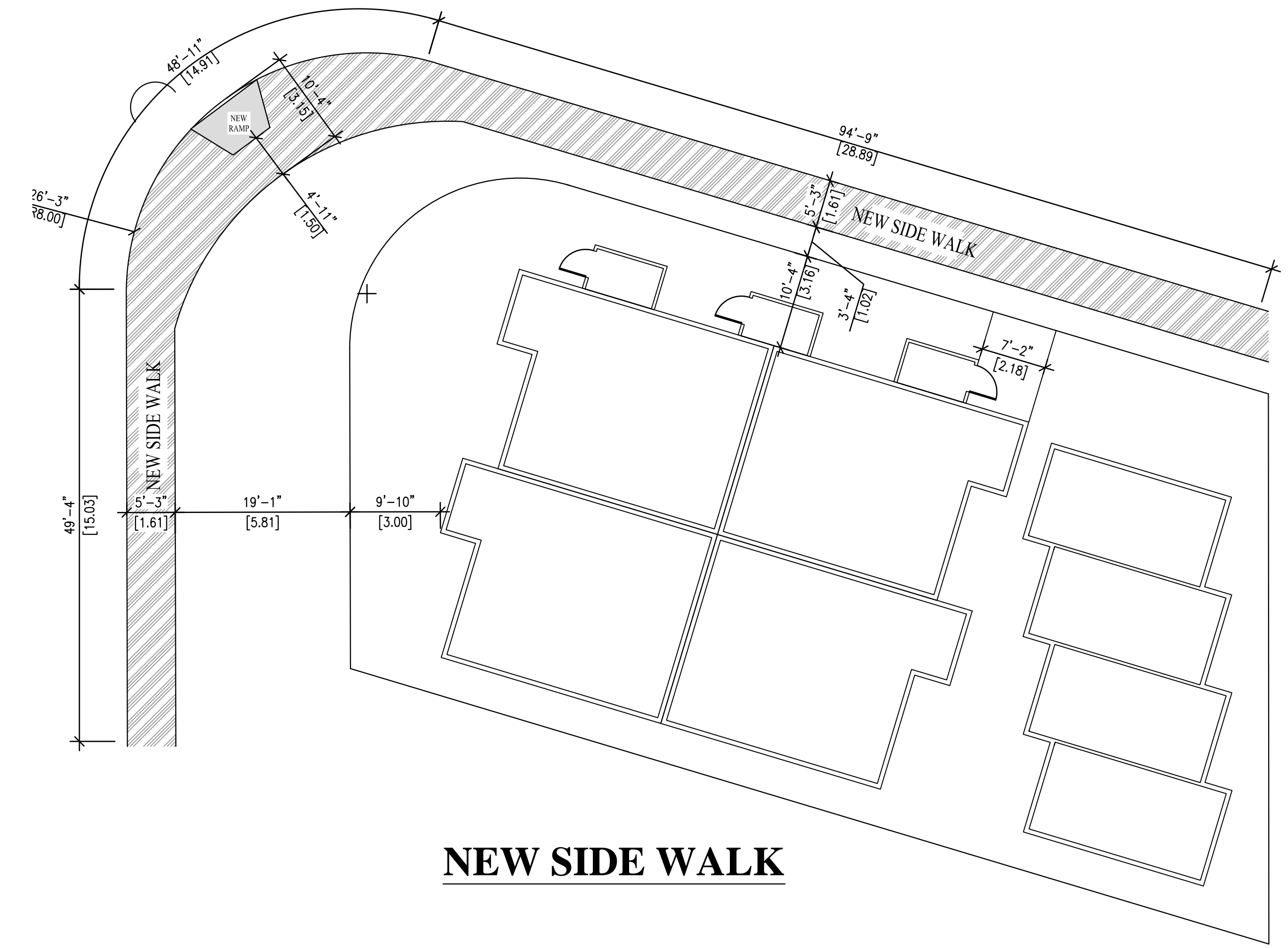

NEW SIDE WALK

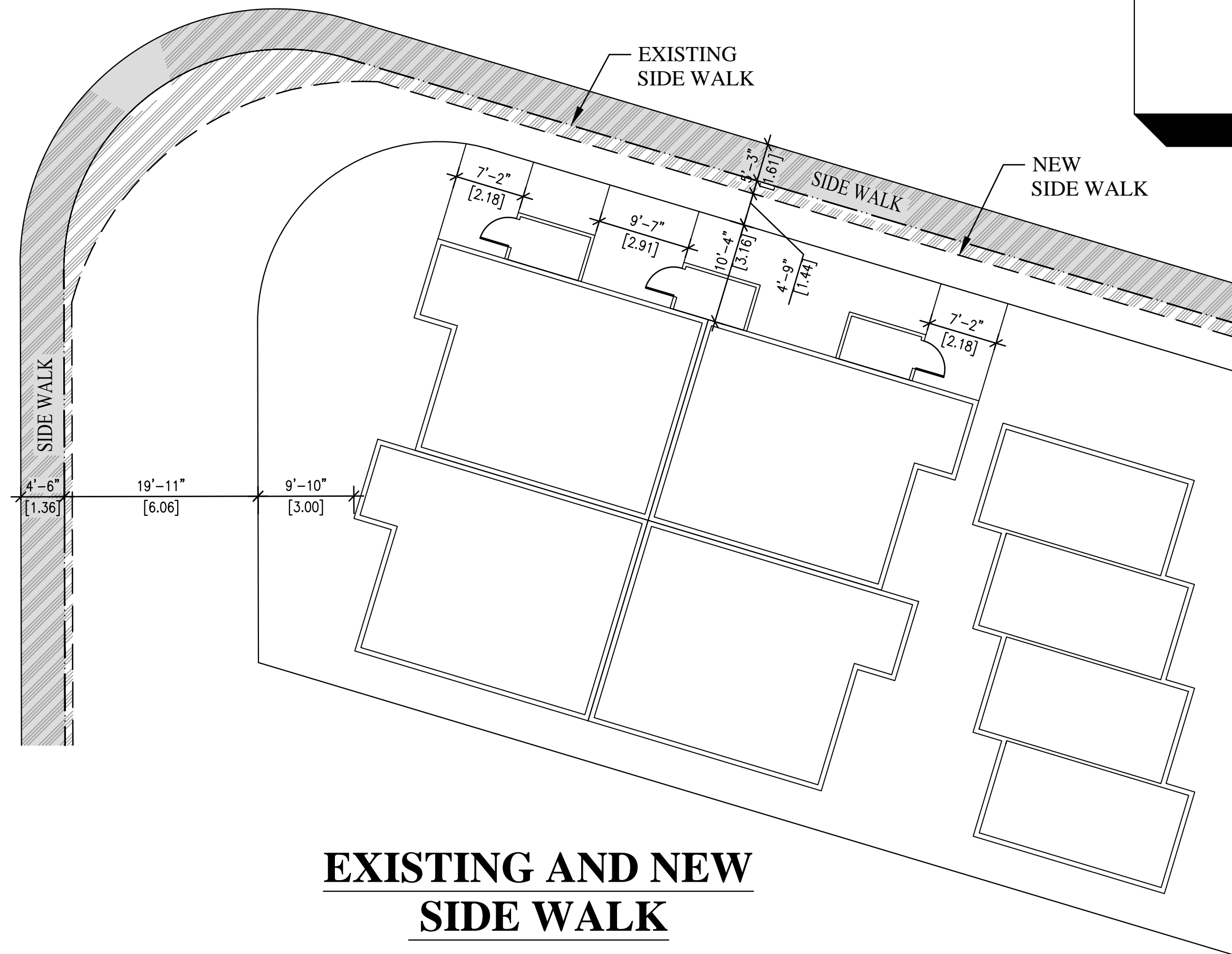

NOTE :-THE WIDTH OF THE EXISTING SIDEWALK IS TO BE REMOVED AND REPLACED WITH A NEW SIDEWALK.

EXISTING AND NEW SIDE WALK

GENERAL NOTE
 THE CONTRACTOR IS RESPONSIBLE FOR ANY ERRORS OR OMISSIONS TO THE DESIGNER PRIOR TO CONSTRUCTION.
 DRAWINGS ARE NOT TO BE SCALED FOR MEASUREMENTS.
 ALL DIMENSIONS SHALL BE VERIFIED BY CONTRACTOR
 ALL DISCREPANCIES SHOULD BE REPORTED TO THE ENGINEER PRIOR TO COMMENCEMENT OF THE WORK.

REV NO.	REVISION/ISSUE	BY	CHK'D	DD/MM/YY
1	ISSUED FOR REVIEW	AV	W	02/03/26
2	ISSUED FOR REVIEW	AV	W	16/02/26
3	ISSUED FOR REVIEW	AV	W	27/01/26
4	ISSUED FOR REVIEW	AV	W	06/12/25
5	ISSUED FOR REVIEW	AV	W	04/12/25
6	ISSUED FOR REVIEW	AV	W	02/12/25

PROJECT:
3939 19th AVENUE S.W.
LOT 19, BLOCK 11
PLAN 8429GQ
CALGARY, ALBERTA

JAYA
DESIGN AND DRAFTING
 PO BOX 30010 Regina, Sk S4N 7K9
 Email: vetovarma@gmail.com

SHEET TITLE	SITE PLAN	DWG NO:
DRAWN:	AV NOV. 25, 2025	SIDE WALK
CHECKED:	WV NOV. 25, 2025	
APPROVED:	WV NOV. 25, 2025	
JOB#:		
SHEET NO:	1 OF 1	DO NOT SCALE THIS DRAWING

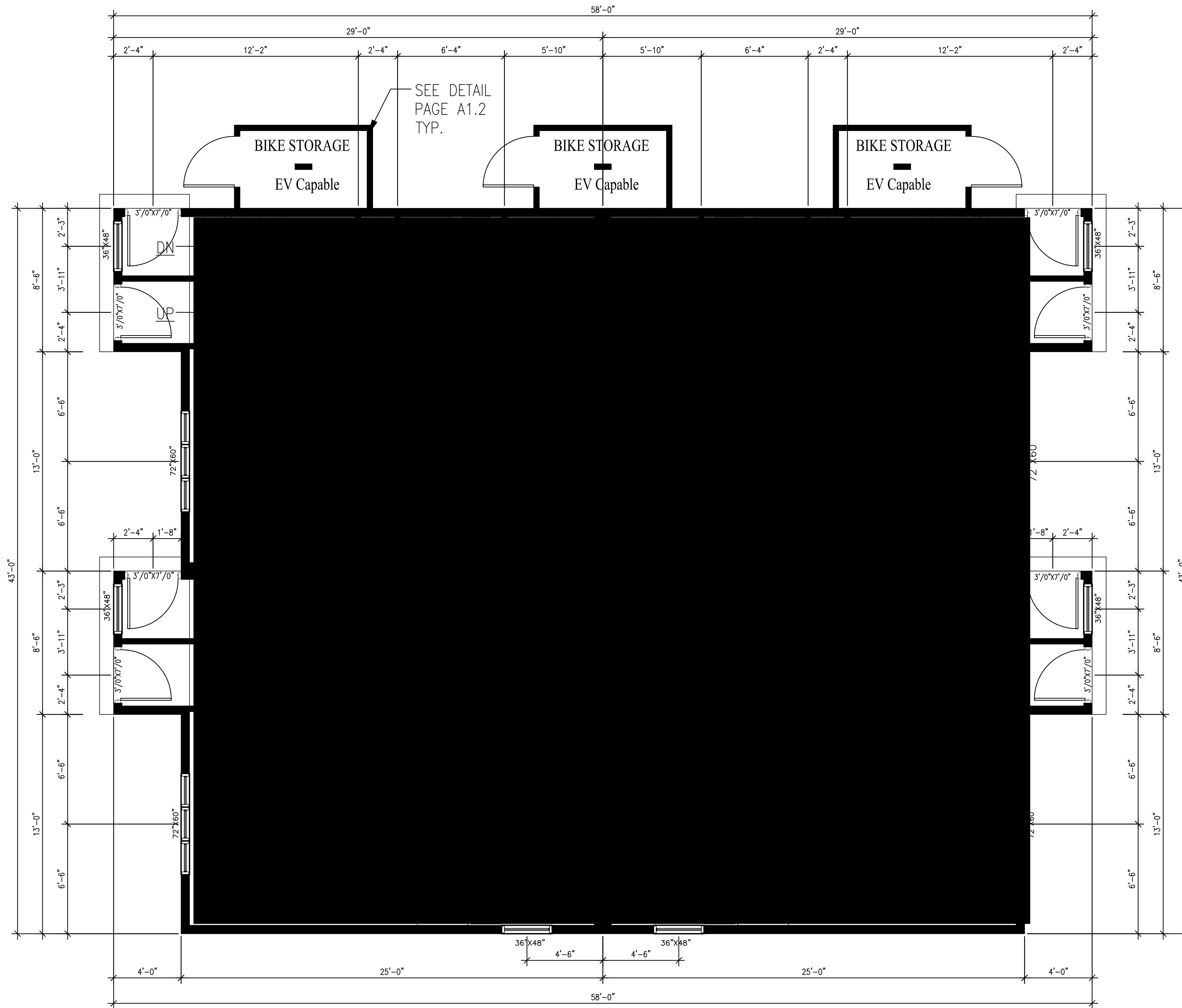

MAIN FLOOR PLAN

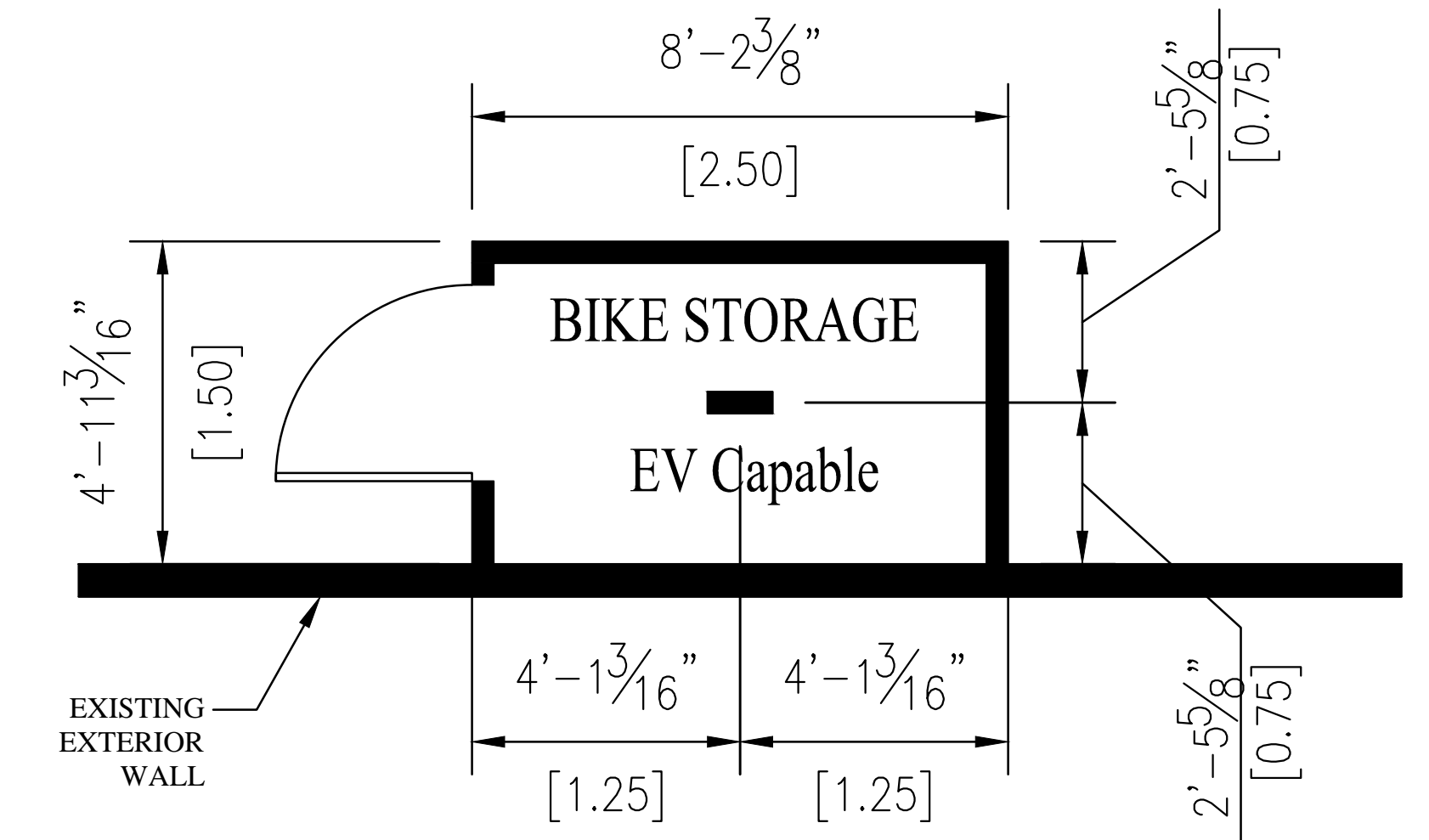

1 MOBILITY STORAGE LOCKERS
A1.2 SCALE: 1:30

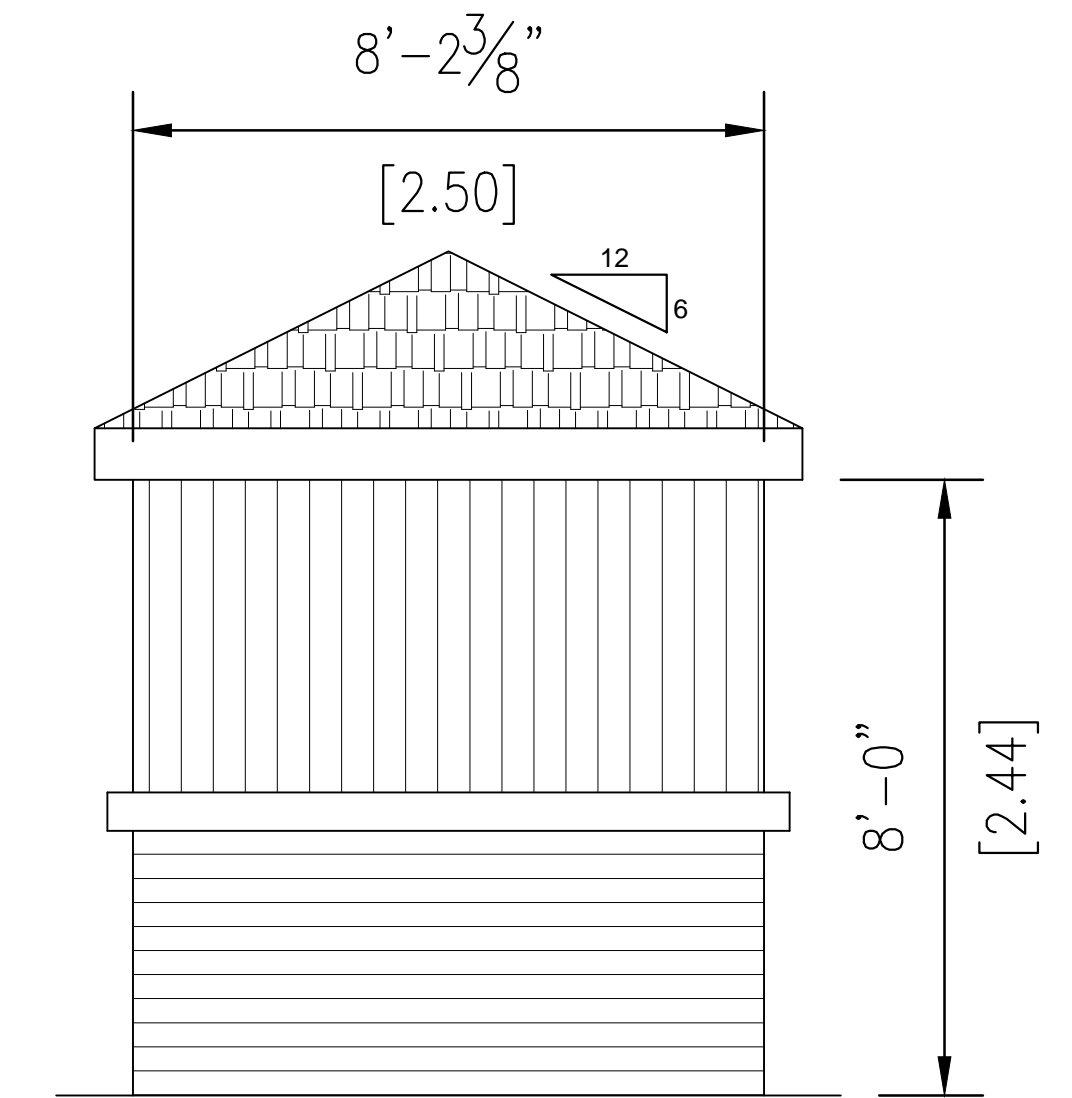

FRONT ELEVATION
SCALE: 1:30

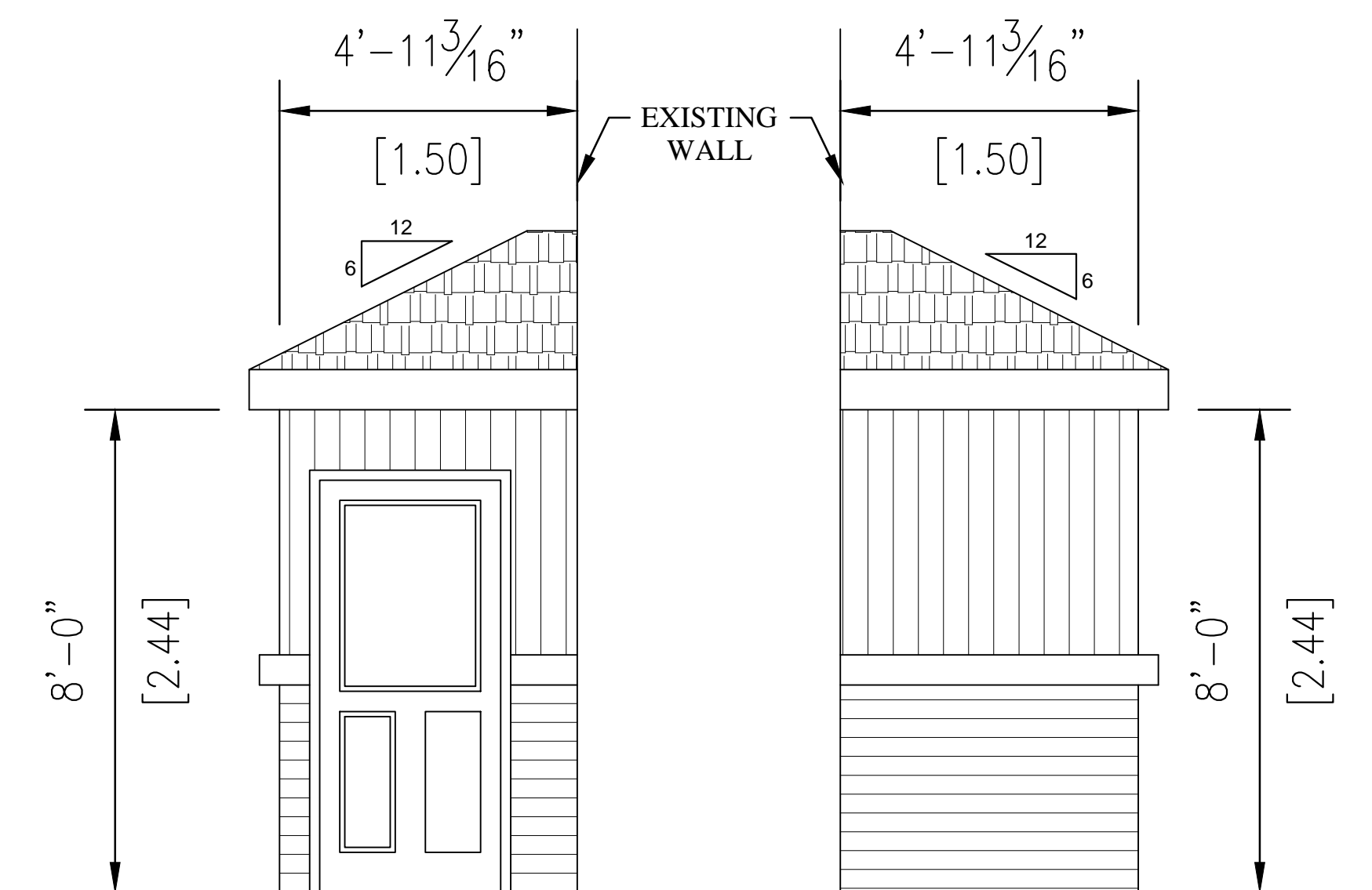

LEFT ELEVATION
SCALE: 1:30

RIGHT ELEVATION
SCALE: 1:30

MAIN FLOOR PLAN

SCALE: 1:40

GENERAL NOTE

THE CONTRACTOR IS RESPONSIBLE FOR ANY ERRORS OR OMISSIONS TO THE DESIGNER PRIOR TO CONSTRUCTION.
DRAWINGS ARE NOT TO BE SCALED FOR MEASUREMENTS.
ALL DIMENSIONS SHALL BE VERIFIED BY CONTRACTOR
ALL DISCREPANCIES SHOULD BE REPORTED TO THE ENGINEER PRIOR TO COMMENCEMENT OF THE WORK.

△	ISSUED FOR REVIEW	AV	W	02/03/26
△	ISSUED FOR REVIEW	AV	W	16/02/26
△	ISSUED FOR REVIEW	AV	W	27/01/26
△	ISSUED FOR REVIEW	AV	W	06/12/25
△	ISSUED FOR REVIEW	AV	W	04/12/25
△	ISSUED FOR REVIEW	AV	W	02/12/25
REV NO.	REVISION/ISSUE	BY	CHK'D	DD/MM/YY

PROJECT:

3939 19th AVENUE S.W.
LOT 19, BLOCK 11
PLAN 8429GQ
CALGARY, ALBERTA

JAYA

DESIGN AND DRAFTING
PO BOX 30010 Regina, Sk S4N 7K9
Email: vetovarma@gmail.com

SHEET TITLE: MAIN FLOOR PLAN

DRAWN: AV NOV. 25, 2025 DWG NO:

CHECKED: WV NOV. 25, 2025

APPROVED: WV NOV. 25, 2025

JOB#:

SHEET NO: 3 OF 8

A1.2

DO NOT SCALE THIS DRAWING

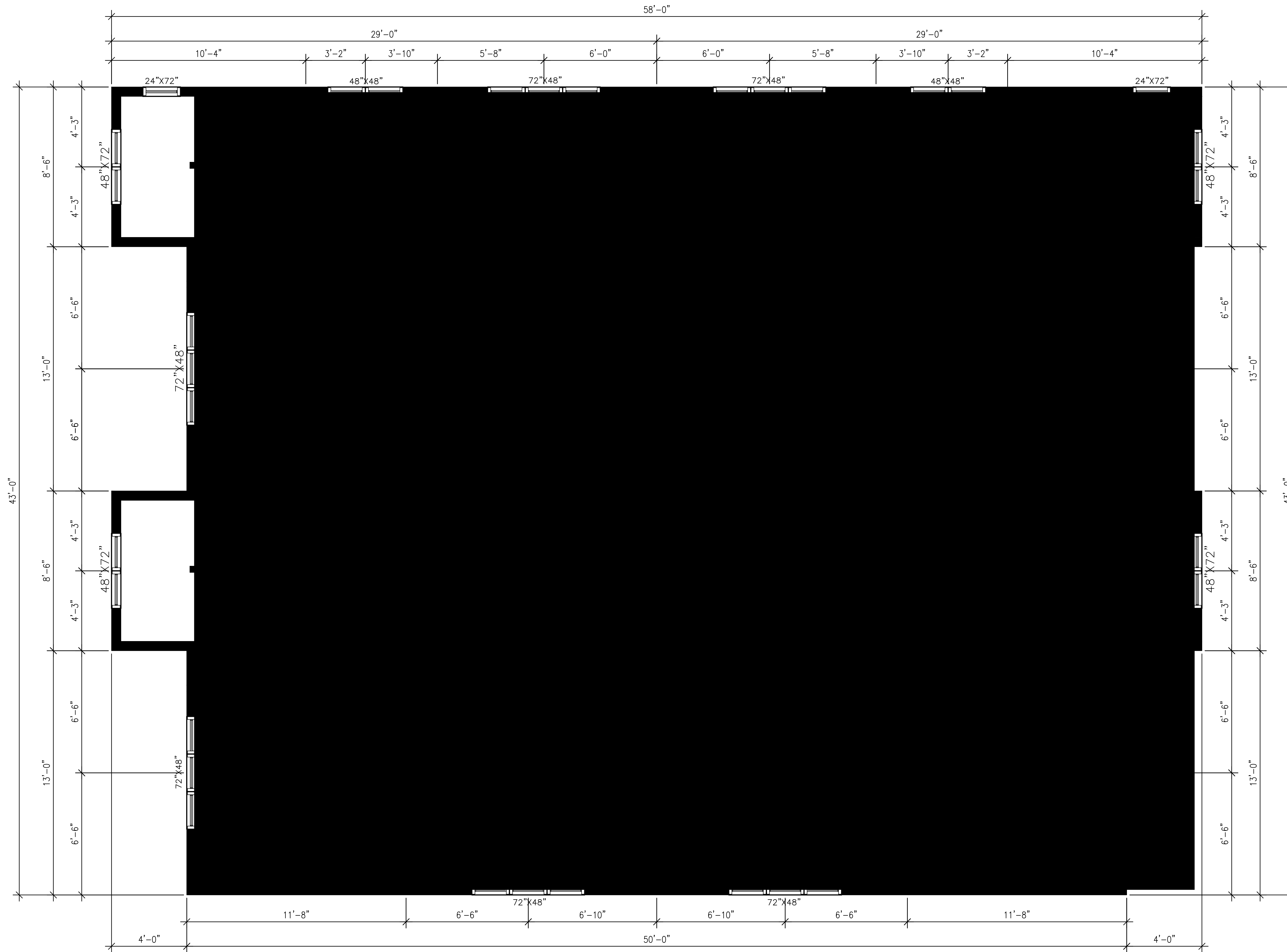

SECOND FLOOR PLAN

SECOND FLOOR PLAN
SCALE: 1:30

GENERAL NOTE
THE CONTRACTOR IS RESPONSIBLE FOR ANY ERRORS OR OMISSIONS TO THE DESIGNER PRIOR TO CONSTRUCTION.
DRAWINGS ARE NOT TO BE SCALED FOR MEASUREMENTS.
ALL DIMENSIONS SHALL BE VERIFIED BY CONTRACTOR
ALL DISCREPANCIES SHOULD BE REPORTED TO THE ENGINEER PRIOR TO COMMENCEMENT OF THE WORK.

REV NO.	REVISION/ISSUE	BY	CHK'D	DD/MM/YY
△	ISSUED FOR REVIEW	AV	W	02/03/26
△	ISSUED FOR REVIEW	AV	W	16/02/26
△	ISSUED FOR REVIEW	AV	W	27/01/26
△	ISSUED FOR REVIEW	AV	W	06/12/25
△	ISSUED FOR REVIEW	AV	W	04/12/25
△	ISSUED FOR REVIEW	AV	W	02/12/25

PROJECT:
3939 19th AVENUE S.W.
LOT 19, BLOCK 11
PLAN 8429GQ
CALGARY, ALBERTA

JAYA
DESIGN AND DRAFTING
PO BOX 30010 Regina, Sk S4N 7K9
Email: vetovarma@gmail.com

SHEET TITLE	SECOND FLOOR PLAN	
DRAWN:	AV NOV. 25, 2025	DWG NO:
CHECKED:	WV NOV. 25, 2025	A1.3
APPROVED:	WV NOV. 25, 2025	
JOB#:		
SHEET NO:	4 OF 8	DO NOT SCALE THIS DRAWING

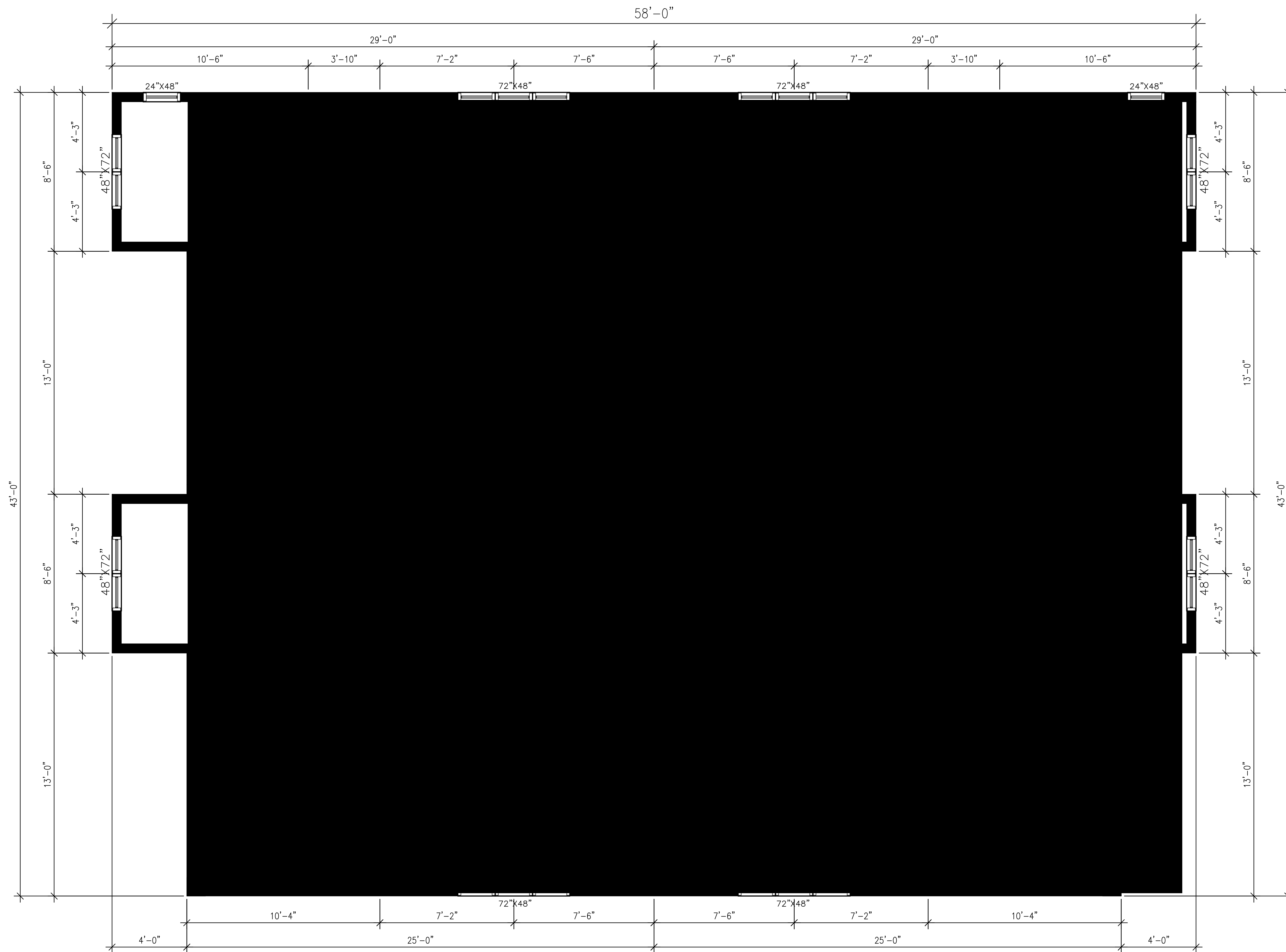

THIRD FLOOR PLAN

THIRD FLOOR PLAN

SCALE: 1:30

GENERAL NOTE

THE CONTRACTOR IS RESPONSIBLE FOR ANY ERRORS OR OMISSIONS TO THE DESIGNER PRIOR TO CONSTRUCTION.
DRAWINGS ARE NOT TO BE SCALED FOR MEASUREMENTS.
ALL DIMENSIONS SHALL BE VERIFIED BY CONTRACTOR
ALL DISCREPANCIES SHOULD BE REPORTED TO THE ENGINEER PRIOR TO COMMENCEMENT OF THE WORK.

△	ISSUED FOR REVIEW	AV	W	02/03/26
△	ISSUED FOR REVIEW	AV	W	16/02/26
△	ISSUED FOR REVIEW	AV	W	27/01/26
△	ISSUED FOR REVIEW	AV	W	06/12/25
△	ISSUED FOR REVIEW	AV	W	04/12/25
△	ISSUED FOR REVIEW	AV	W	02/12/25
REV NO.	REVISION/ISSUE	BY	CHK'D	DD/MM/YY

PROJECT:

3939 19th AVENUE S.W.
LOT 19, BLOCK 11
PLAN 8429GQ
CALGARY, ALBERTA

JAYA

DESIGN AND DRAFTING
 PO BOX 30010 Regina, Sk S4N 7K9
 Email: vetovarma@gmail.com

SHEET TITLE	THIRD FLOOR PLAN	
DRAWN:	AV NOV. 25, 2025	DWG NO:
CHECKED:	WV NOV. 25, 2025	A1.4
APPROVED:	WV NOV. 25, 2025	
JOB#:		
SHEET NO:	5 OF 8	DO NOT SCALE THIS DRAWING

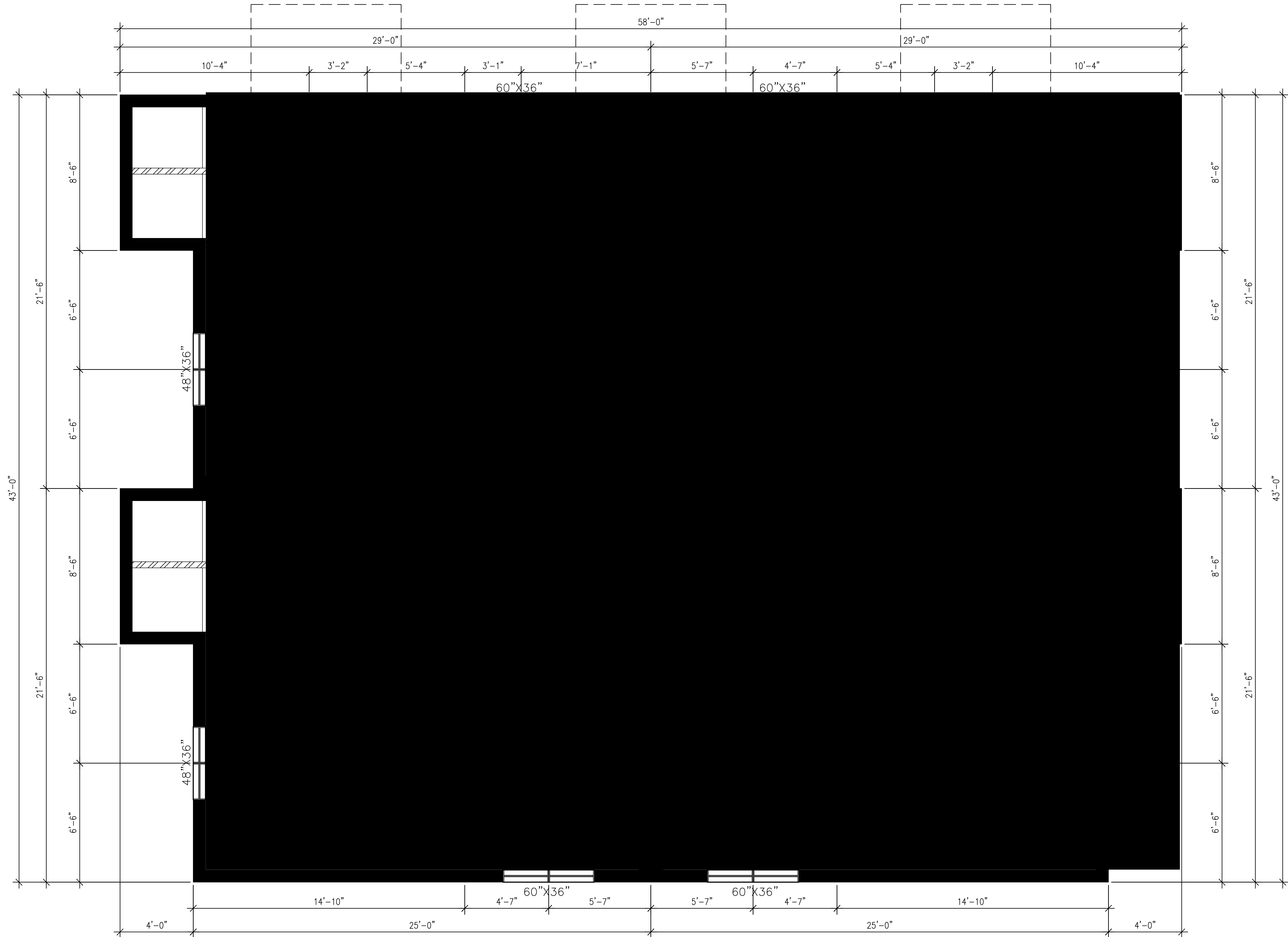

BASEMENT PLAN

BASEMENT PLAN

SCALE: 1:30

GENERAL NOTE

THE CONTRACTOR IS RESPONSIBLE FOR ANY ERRORS OR OMISSIONS TO THE DESIGNER PRIOR TO CONSTRUCTION.
DRAWINGS ARE NOT TO BE SCALED FOR MEASUREMENTS.
ALL DIMENSIONS SHALL BE VERIFIED BY CONTRACTOR
ALL DISCREPANCIES SHOULD BE REPORTED TO THE ENGINEER PRIOR TO COMMENCEMENT OF THE WORK.

△	ISSUED FOR REVIEW	AV	W	02/03/26
△	ISSUED FOR REVIEW	AV	W	16/02/26
△	ISSUED FOR REVIEW	AV	W	27/01/26
△	ISSUED FOR REVIEW	AV	W	06/12/25
△	ISSUED FOR REVIEW	AV	W	04/12/25
△	ISSUED FOR REVIEW	AV	W	02/12/25
REV NO.	REVISION/ISSUE	BY	CHK'D	DD/MM/YY

PROJECT:

3939 19th AVENUE S.W.
LOT 19, BLOCK 11
PLAN 8429GQ
CALGARY, ALBERTA

JAYA

DESIGN AND DRAFTING
PO BOX 30010 Regina, Sk S4N 7K9
Email: vetovarma@gmail.com

SHEET TITLE	BASEMENT PLAN		DWG NO:
DRAWN:	AV	NOV. 25, 2025	A1.5
CHECKED:	WV	NOV. 25, 2025	
APPROVED:	WV	NOV. 25, 2025	
JOB#:			
SHEET NO:	6 OF 8		DO NOT SCALE THIS DRAWING

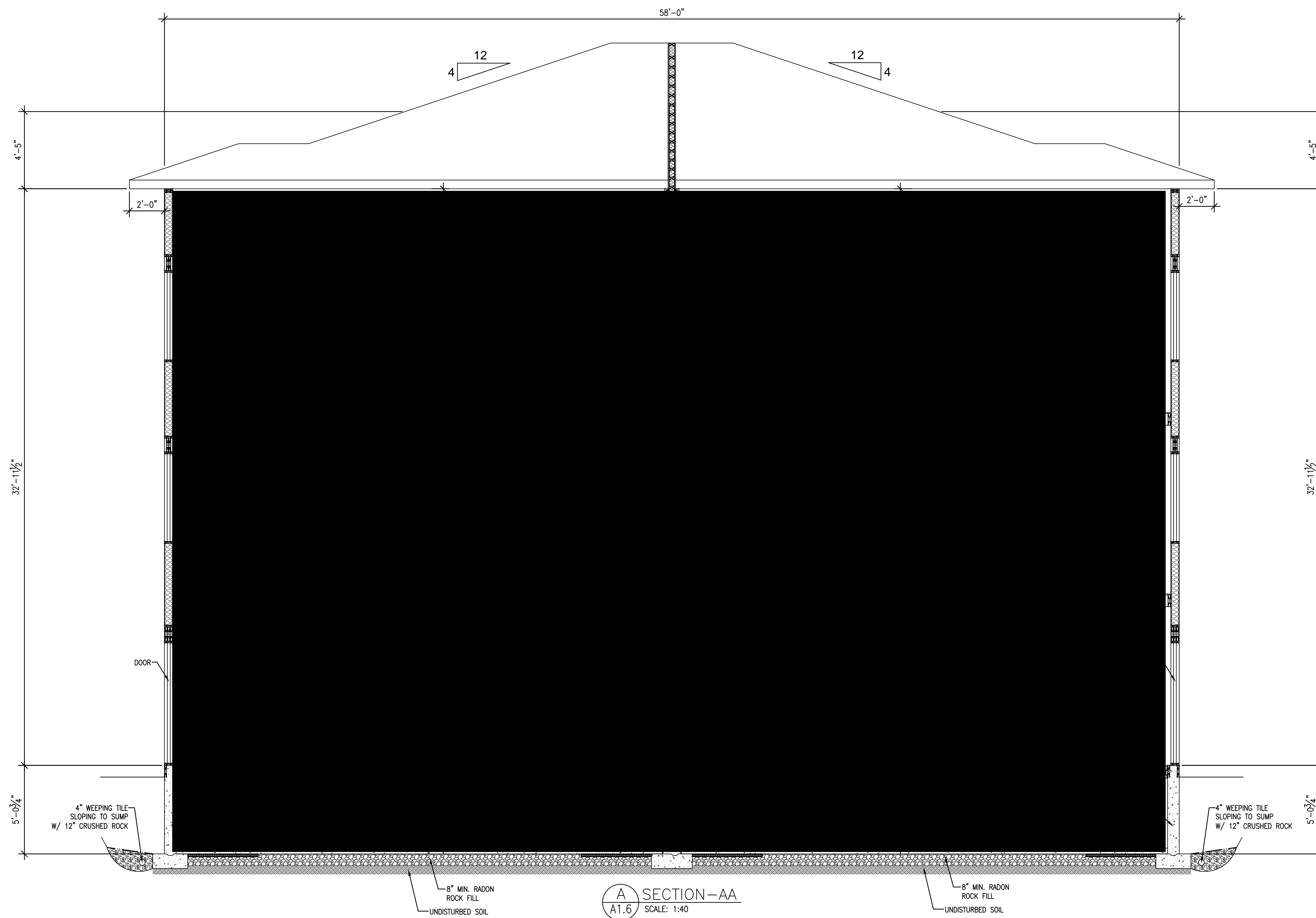

A SECTION-AA
A1.6 SCALE: 1:40

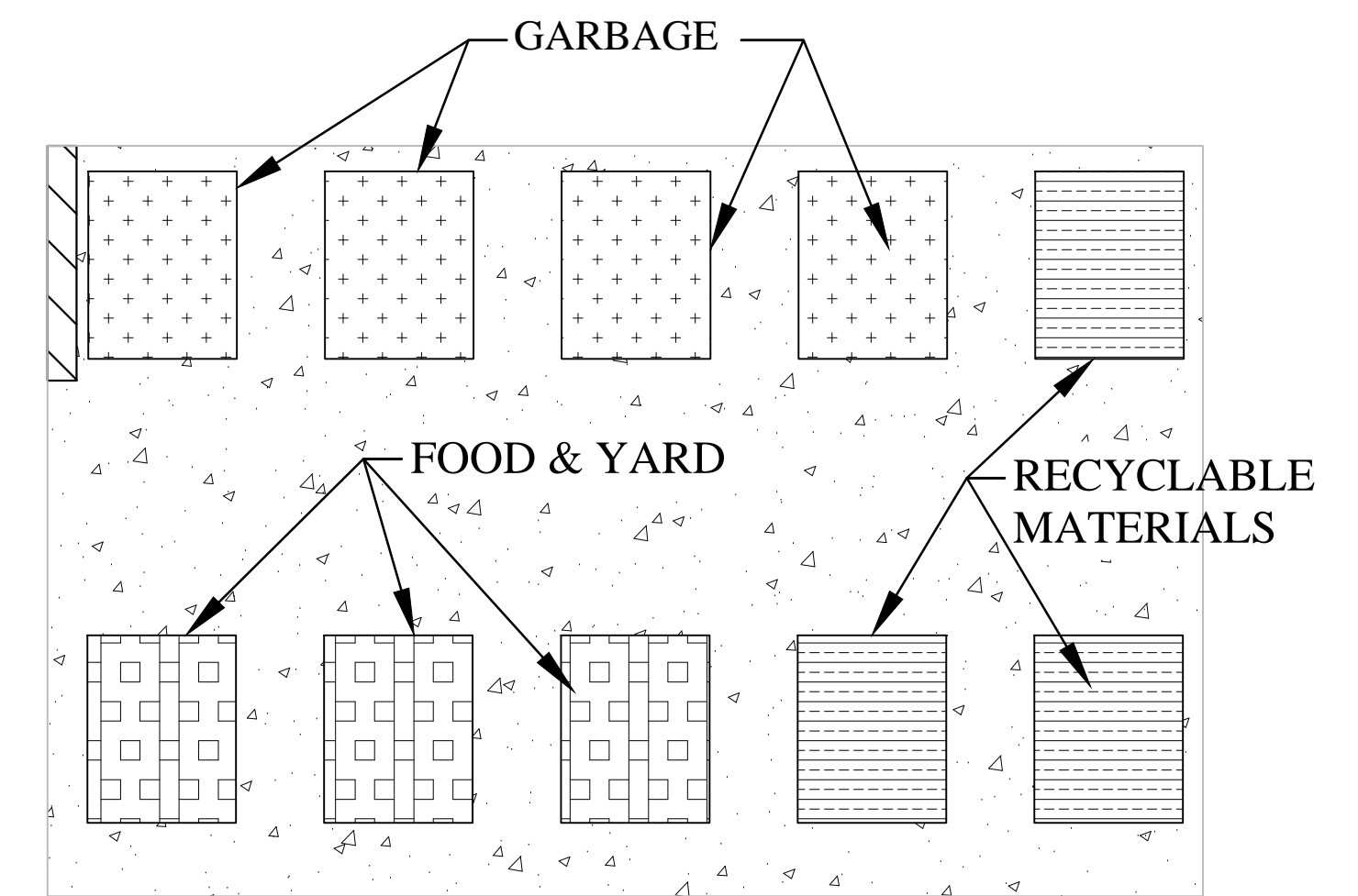

WAST DISPOSAL AREA

1 DETAIL
A1.6 N.T.S.

GENERAL NOTE
THE CONTRACTOR IS RESPONSIBLE FOR ANY ERRORS OR OMISSIONS TO THE DESIGNER PRIOR TO CONSTRUCTION.
DRAWINGS ARE NOT TO BE SCALED FOR MEASUREMENTS.
ALL DIMENSIONS SHALL BE VERIFIED BY CONTRACTOR
ALL DISCREPANCIES SHOULD BE REPORTED TO THE ENGINEER PRIOR TO COMMENCEMENT OF THE WORK.

REV NO.	REVISION/ISSUE	BY	CHK'D	DD/MM/YY
△	ISSUED FOR REVIEW	AV	W	02/03/26
△	ISSUED FOR REVIEW	AV	W	16/02/26
△	ISSUED FOR REVIEW	AV	W	27/01/26
△	ISSUED FOR REVIEW	AV	W	06/12/25
△	ISSUED FOR REVIEW	AV	W	04/12/25
△	ISSUED FOR REVIEW	AV	W	02/12/25

PROJECT:
3939 19th AVENUE S.W.
LOT 19, BLOCK 11
PLAN 8429GQ
CALGARY, ALBERTA

JAYA
DESIGN AND DRAFTING
PO BOX 30010 Regina, Sk S4N 7K9
Email: vetovarma@gmail.com

SHEET TITLE	SECTION-AA	DWG NO:
DRAWN:	AV NOV. 25, 2025	A1.6
CHECKED:	WV NOV. 25, 2025	
APPROVED:	WV NOV. 25, 2025	
JOB#:		
SHEET NO:	7 OF 8	DO NOT SCALE THIS DRAWING

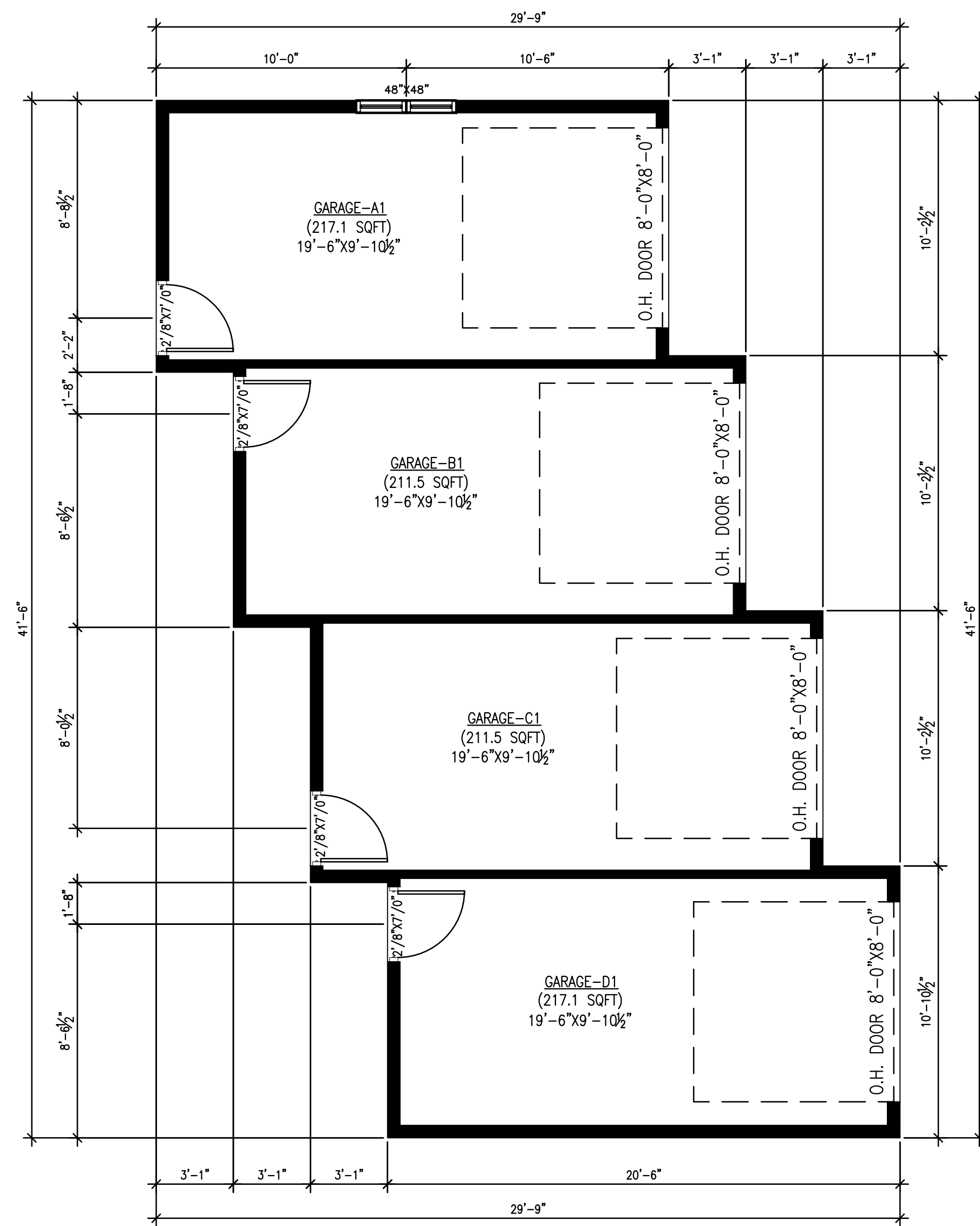

GARAGE PLAN
SCALE: 1:50

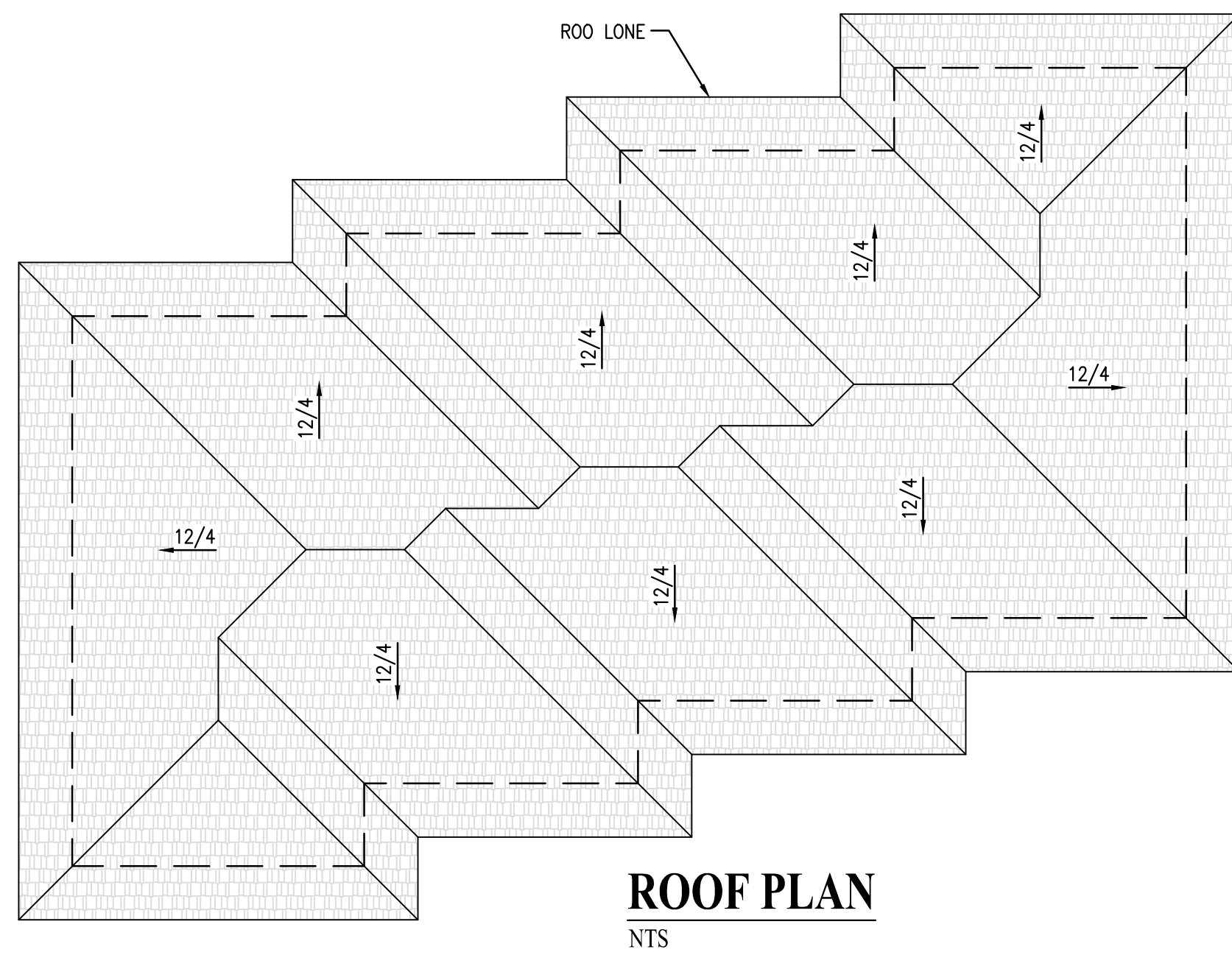

ROOF PLAN
NTS

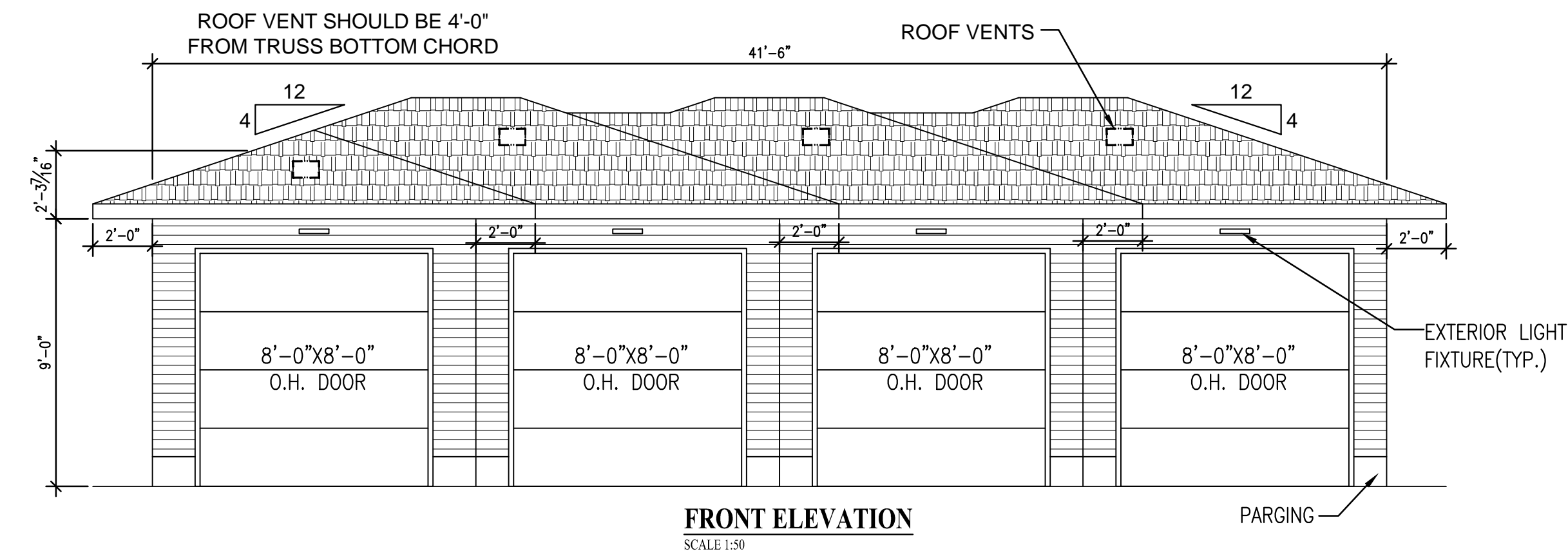

FRONT ELEVATION
SCALE 1:50

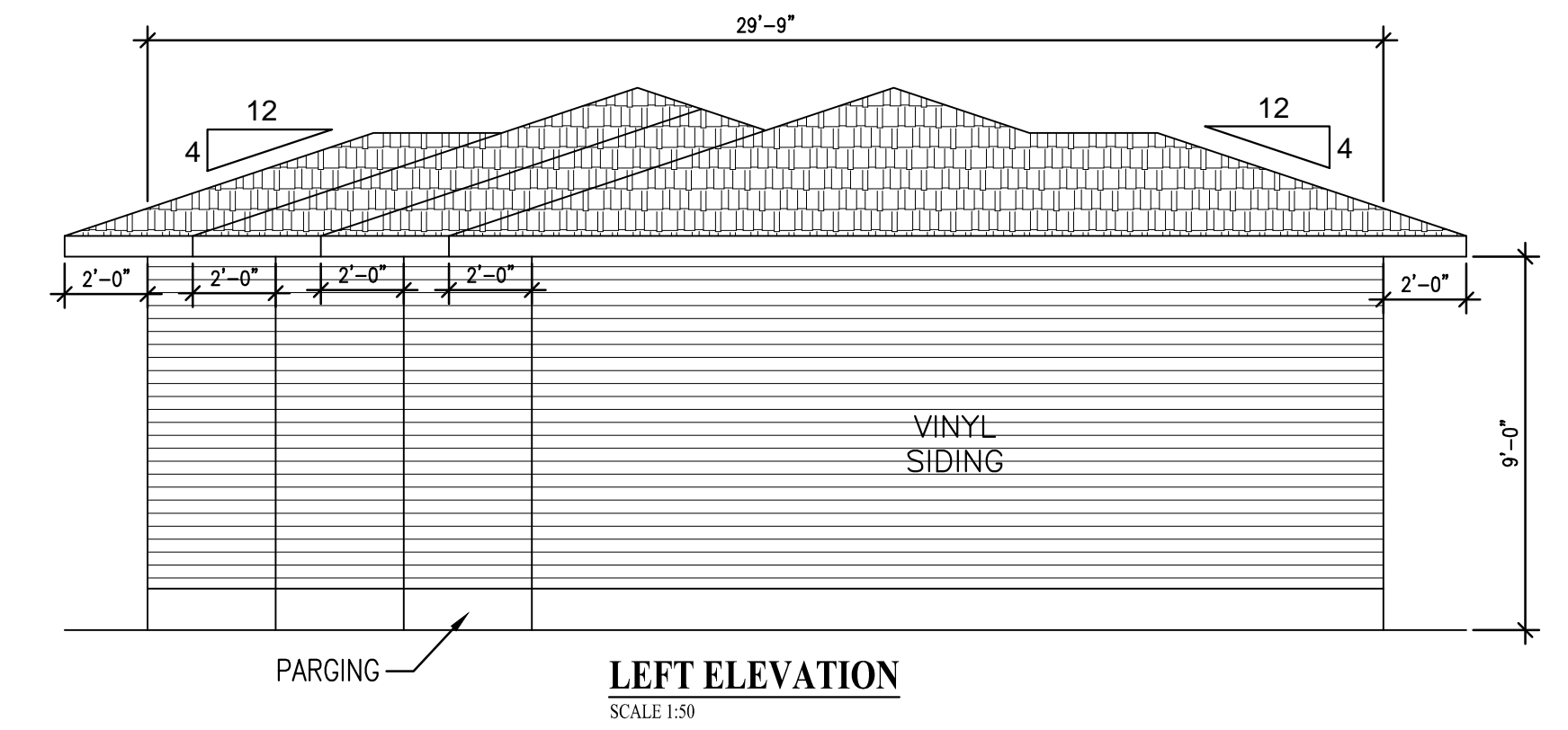

LEFT ELEVATION
SCALE 1:50

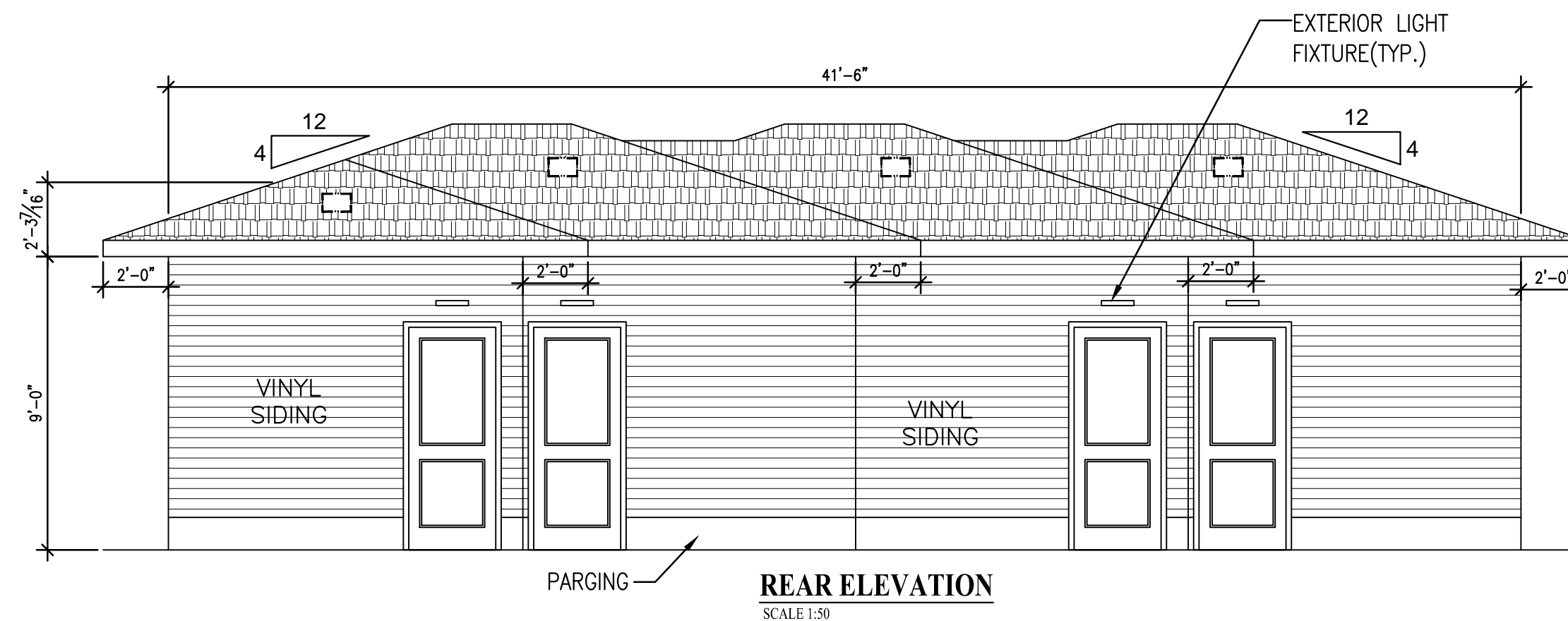

REAR ELEVATION
SCALE 1:50

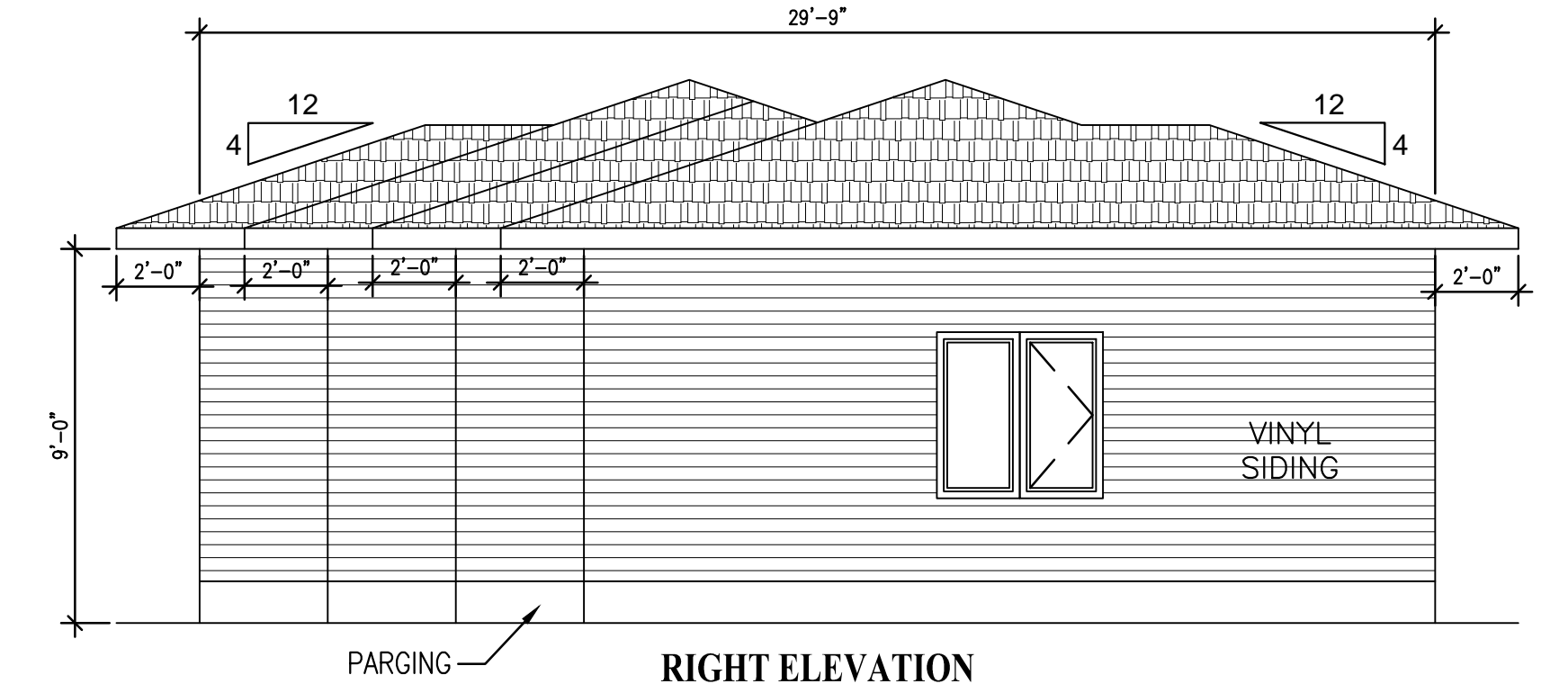

RIGHT ELEVATION
SCALE 1:50

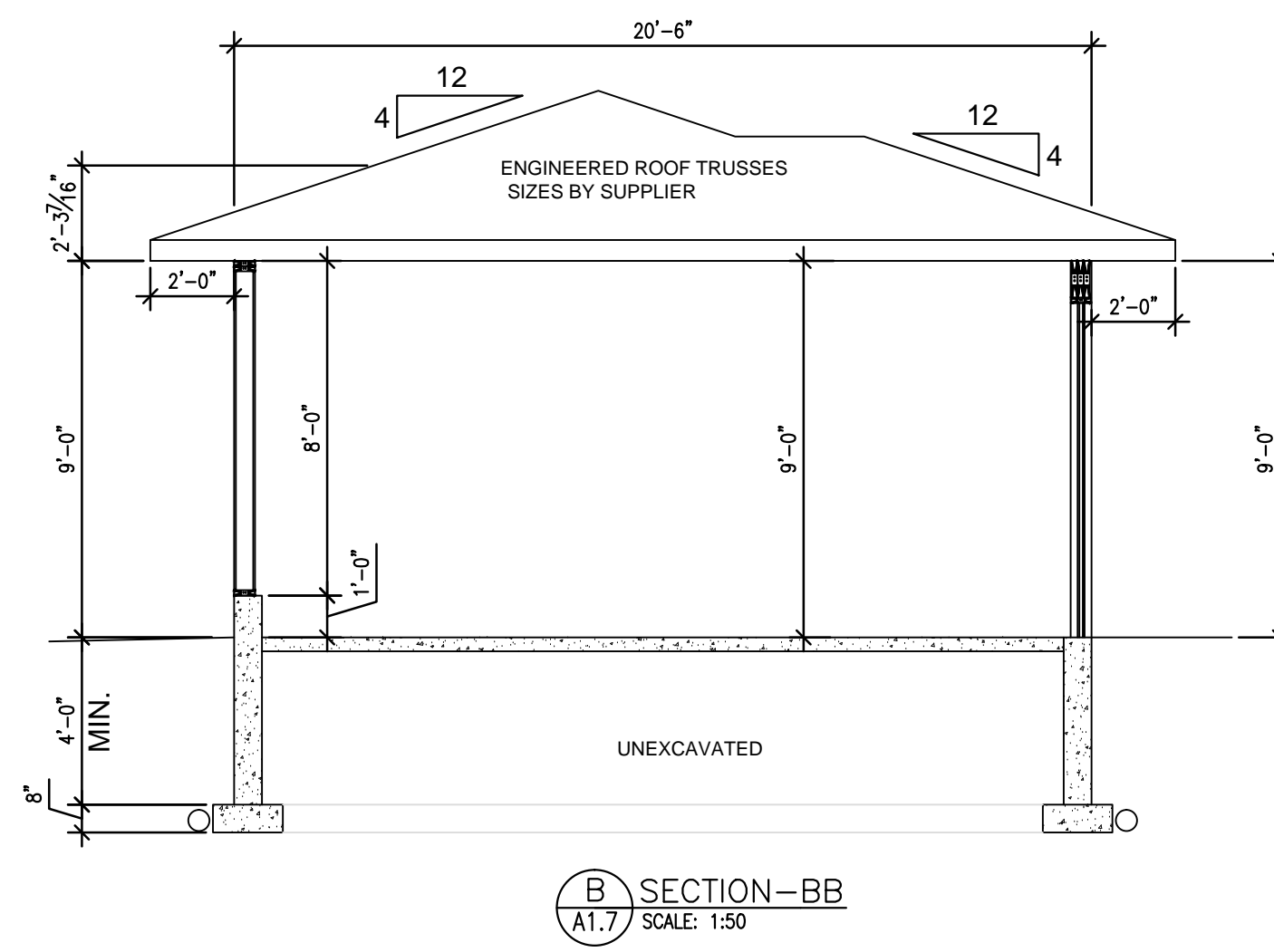

B SECTION-BB
A1.7 SCALE: 1:50

NOTE:- ROOF LAYOUT SHOWN IS TENTATIVE ONLY AND SHALL BE CONFIRMED WITH ROOF SUPPLIER. ROOF DESIGN BY SUPPLIER

GENERAL NOTE

THE CONTRACTOR IS RESPONSIBLE FOR ANY ERRORS OR OMISSIONS TO THE DESIGNER PRIOR TO CONSTRUCTION.
DRAWINGS ARE NOT TO BE SCALED FOR MEASUREMENTS.
ALL DIMENSIONS SHALL BE VERIFIED BY CONTRACTOR
ALL DISCREPANCIES SHOULD BE REPORTED TO THE ENGINEER PRIOR TO COMMENCEMENT OF THE WORK.

REV NO.	REVISION/ISSUE	BY	CHK'D	DD/MM/YY
1	ISSUED FOR REVIEW	AV	W	02/03/26
2	ISSUED FOR REVIEW	AV	W	16/02/26
3	ISSUED FOR REVIEW	AV	W	27/01/26
4	ISSUED FOR REVIEW	AV	W	06/12/25
5	ISSUED FOR REVIEW	AV	W	04/12/25
6	ISSUED FOR REVIEW	AV	W	02/12/25
7	REVISION/ISSUE	BY	CHK'D	DD/MM/YY

PROJECT:

3939 19th AVENUE S.W.
LOT 19, BLOCK 11
PLAN 8429GQ
CALGARY, ALBERTA

JAYA
DESIGN AND DRAFTING
PO BOX 30010 Regina, Sk S4N 7K9
Email: vetovarma@gmail.com

SHEET TITLE	GARAGE PLAN SECTION & ELEVATIONS	
DRAWN:	AV NOV. 25, 2025	DWG NO:
CHECKED:	WV NOV. 25, 2025	A1.7
APPROVED:	WV NOV. 25, 2025	
JOB#:		
SHEET NO:	8 OF 8	DO NOT SCALE THIS DRAWING