

Site Coverage: 341.07 m2
 (House/Porch - 260.65 m2)
 (Garage/Garbage/ 80.42m2)
 1/2 Visitor Stall - 720.09 m2
 Site Area: 58.77 %

554 of Bylaw - 40% reduction on landscaping -
 2.0m2 per 1.0m frontage = 2x15.28m (30.56m2) 4.24%

Required Landscaping: 40% - 4.24% = 35.76%
 Actual Landscaping: 41.23%
 Hard Landscaping: 108.01m2 (47.72%)

Less 50% of Visitor stall hard landscaping = 17.56 m2 /2=
 8.78 m2 New hard landscaping: 99.23 m2 (41.47%)
 New soft landscaping: 140.05 m2 (58.53%)

319, 32nd AVENUE N.E.
 LOT 20 & 21, BLOCK 67, PLAN 2617 AG

FLOOR	GROSS
MAIN	257.43 SQ. M. (2,770.00 SQ. FT.)
UPPER	266.58 SQ. M. (2,869.50 SQ. FT.)
THIRD	228.16 SQ. M. (2,456.00 SQ. FT.)

TOTAL 752.05 SQ. M. (8,095.50 SQ. FT.)

DENSITY:
 R-CG DENSITY = 75 UNITS/HECTARE
 SUBJECT SITE = 720.09 SQ. M. (0.072 Ha) = 5.40 UNITS
 ALLOWABLE (ACTUAL = 4 UNITS)

TREE INFORMATION CHART						
TREE	Type	Canopy	Height	Diameter	Status	Location
1	GREEN ASH	10.4	9	0.6	TO REMAIN	CITY PROPERTY
2	GREEN ASH	11.1	14	0.5	TO BE REMOVED	CITY PROPERTY
3	GREEN ASH	10.7	12	0.3	TO REMAIN	CITY PROPERTY

NOTE: LANDSCAPED AREAS TO HAVE UNDERGROUND IRRIGATION SYSTEM
 NOTE: ALL PLANT BEDS TO HAVE BLACK MULCH FILL
 NOTE: ALL SODDED AREAS TO BE MADE UP OF DROUGHT RESISTANT SPECIES
 NOTE: MINIMUM TOPSOIL DEPTH TO BE 300mm FOR ALL ABSORBENT LANDSCAPE AREAS
 AND 600mm FOR PLANT BEDS WITH SHRUBS

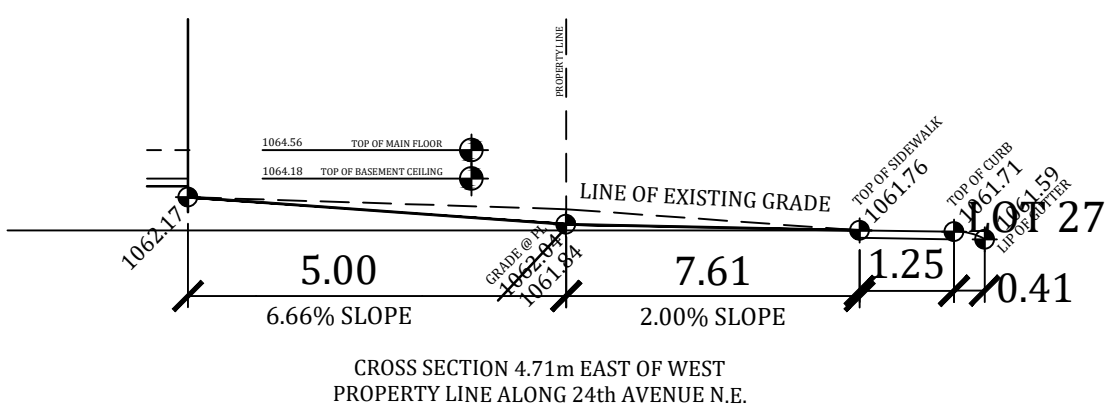

1 BOULEVARD CROSS SECTION
 SCALE: 1:100

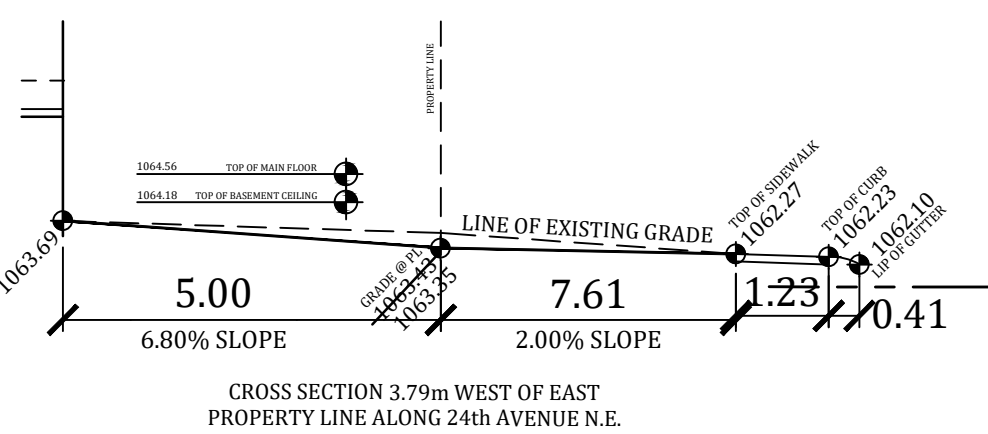

2 BOULEVARD CROSS SECTION
 SCALE: 1:100

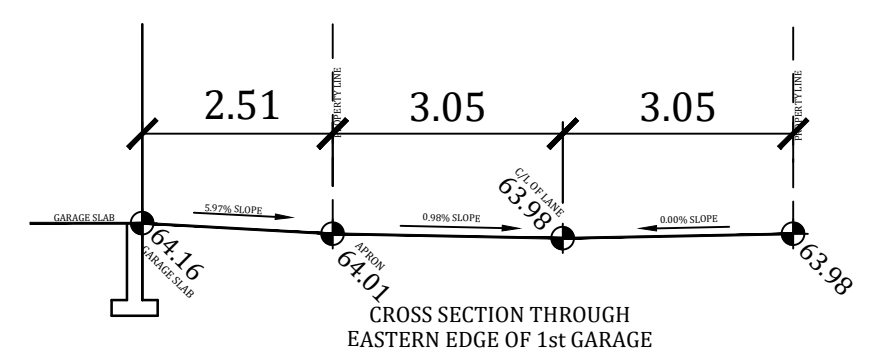

3 APRON/LANE CROSS SECTION
 SCALE: 1:100

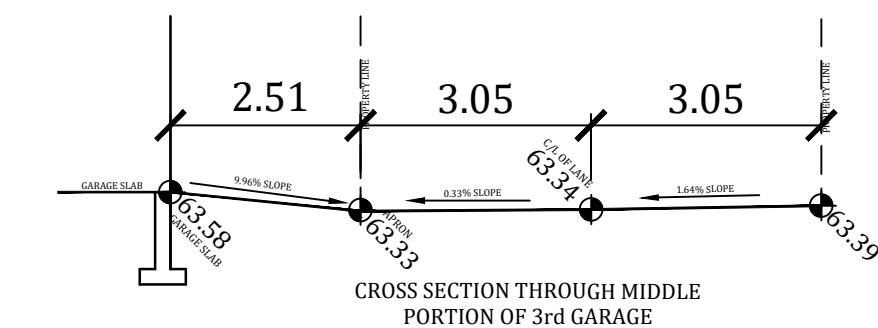

5 APRON/LANE CROSS SECTION
 SCALE: 1:100

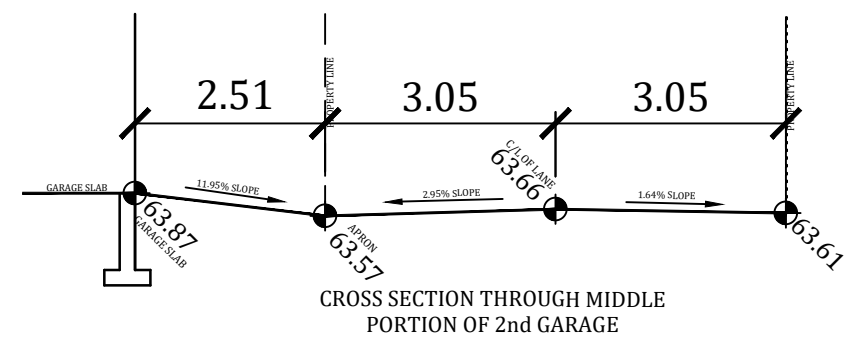

4 APRON/LANE CROSS SECTION
 SCALE: 1:100

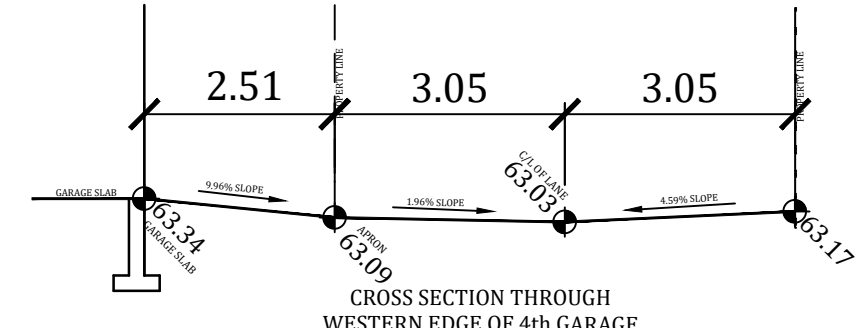

6 APRON/LANE CROSS SECTION
 SCALE: 1:100

OVERALL SITE PLAN
 SCALE: 1:150

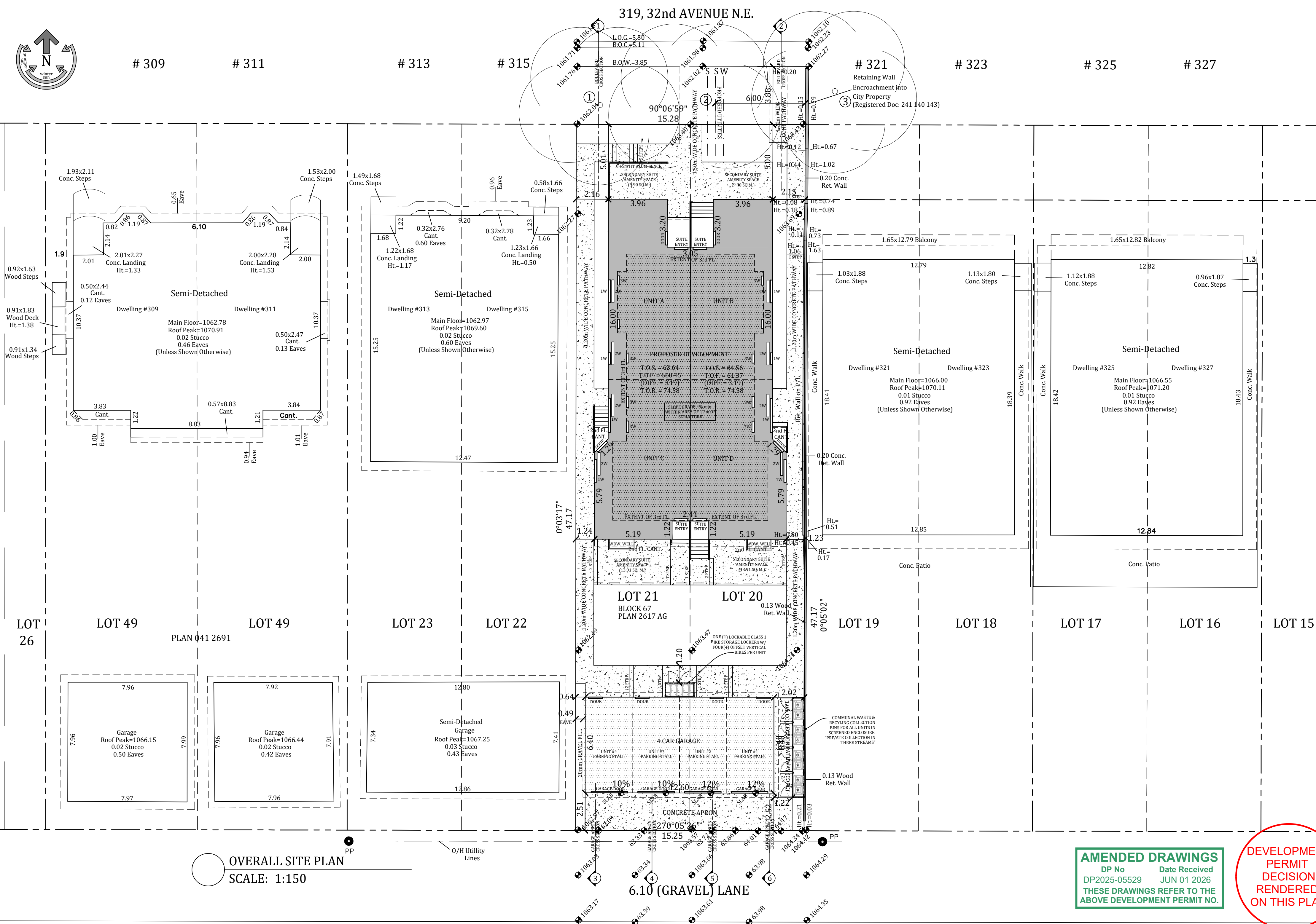

AMENDED DRAWINGS
 DP No DP2025-05529 Date Received JUN 01 2026
 THESE DRAWINGS REFER TO THE ABOVE DEVELOPMENT PERMIT NO.

DEVELOPMENT PERMIT DECISION RENDERED ON THIS PLAN

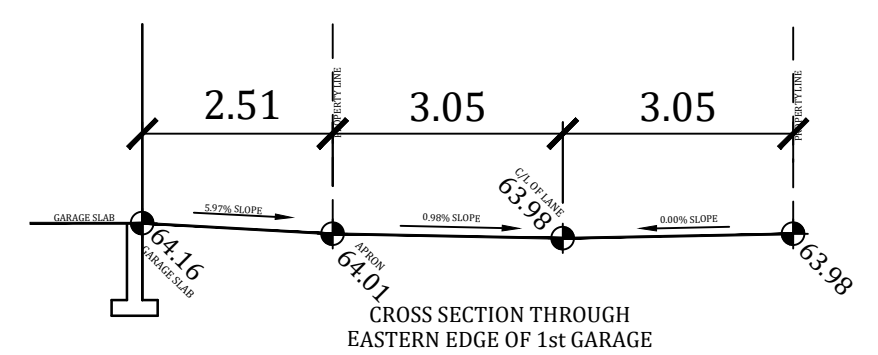

3 APRON/LANE CROSS SECTION
 SCALE: 1:100

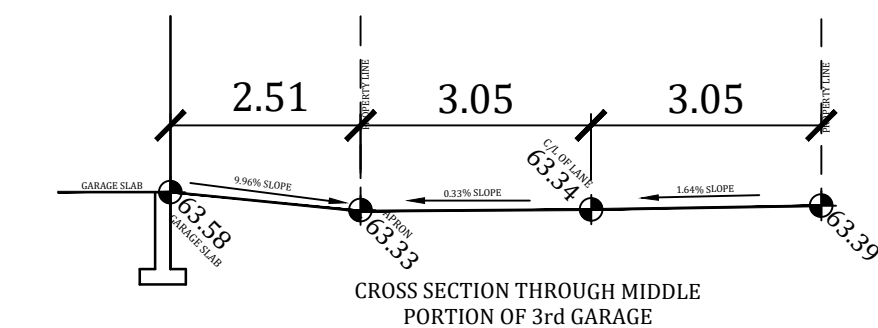

5 APRON/LANE CROSS SECTION
 SCALE: 1:100

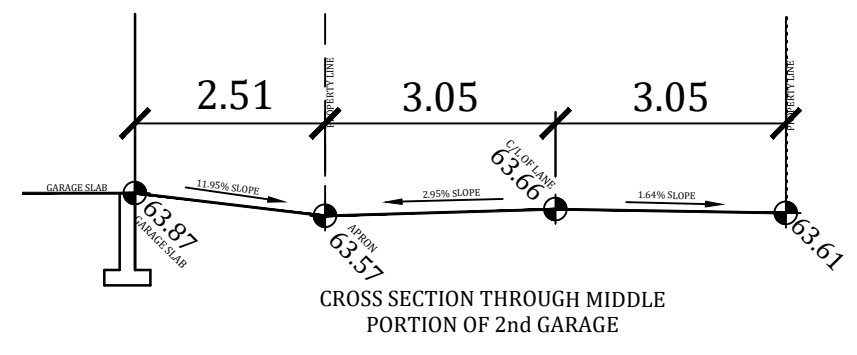

4 APRON/LANE CROSS SECTION
 SCALE: 1:100

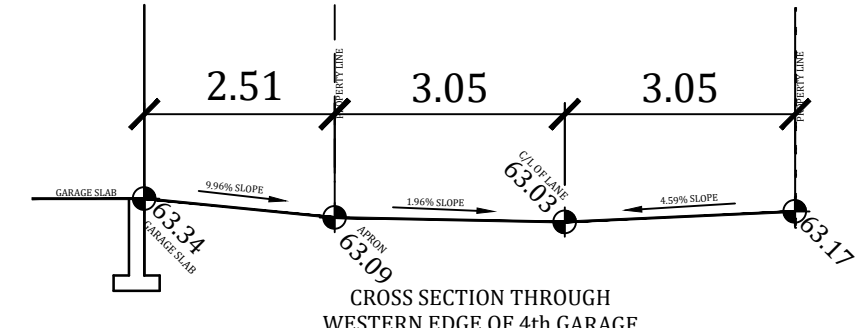

6 APRON/LANE CROSS SECTION
 SCALE: 1:100

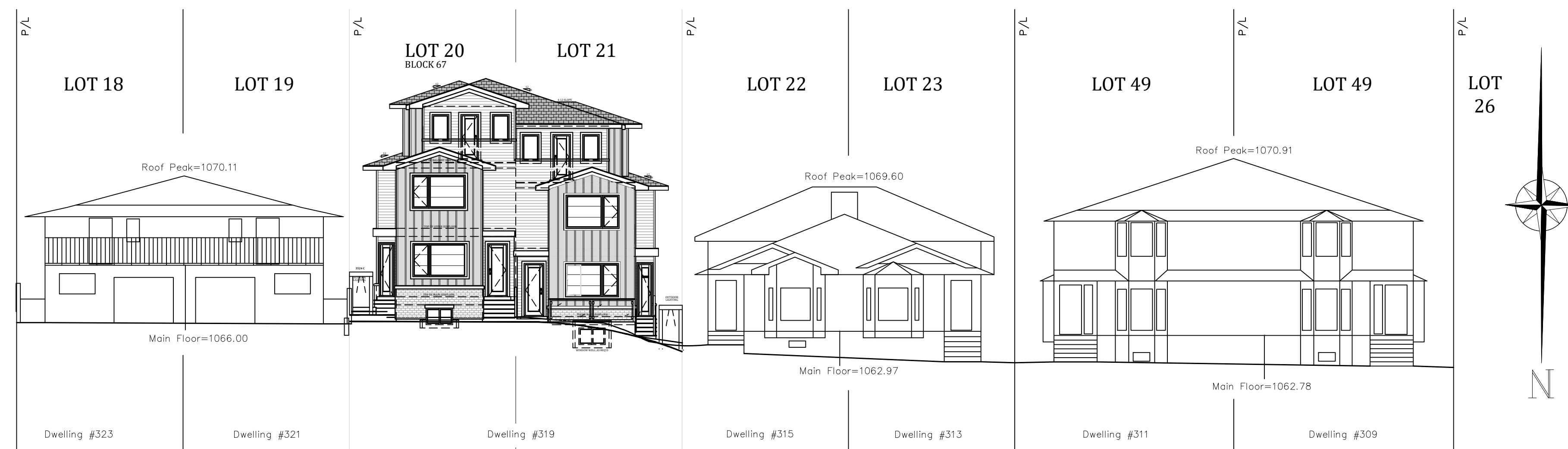

designhaus
 STUDIO INC.

155 ELGIN TERRACE S.E.
 CALGARY, AB T2Z 0G3
 TEL: (403) 399 - 2930

www.designhausstudio.com

Need the Full Plans?
 If you need the full set of plans or need changes, call 403.399.2930 or email info@designhausstudio.com for details.

Digital Plans
 A PDF version of this plan is available. Call 403.399.2930 or email info@designhausstudio.com for copies.

Copyright
 Designhaus Studio Inc. reserves the rights to these documents and to all designs contained herein. No copies or alterations are to be made without expressed written permission from the designer. All plans sold by Designhaus Studio Inc. are protected under copyright law.

Liability Disclaimer
 Placement of the residence on the site plan is based on owners desired location and governing authority's regulations. Every property has inherent risks due to location, acts of God, etc... which may cause damage to structures built on said property and bodily injury and/or death to the occupants of said structures. Designhaus Studio Inc. does not in any way guarantee the suitability or any area for construction or habitation, and will not be held liable for damages based on the location of said structure. General Contractor to verify all field conditions and code requirements, insure compliance of proposed structure with said conditions, verify all dimensions & techniques in construction documents, and notify Designhaus Studio Inc. of any discrepancies before construction.

APRIL 29, 2026

OVERALL SITE PLAN - FOURPLEX
 319 32nd AVENUE N.E.
 SITE PLAN & STREETScape

Index of pages

A1	Site plan
A2	Landscape plans
A3	Main floor plan
A4	Upper floor plan
A5	Third floor plan
A6	Lower floor plan
A7	North & West elevations
A8	South & East elevations
A9	Structural Cross Sections
A10	Construction Details

A1

LANDSCAPE LEGEND				
Variety	Trunk (Ø±)	Quantity	Height (±)	Location
Coniferous	2.0 (SPRUCE)	2.0	3.0m	FRONT YARD (N.W.)
Deciduous	5.0 (3 COLUMNAR) (2 MAYDAY)	2.0m/3.0m 60/85mm		FRONT YARD/ REAR YARD
Shrubbery	34.0	0.60m /0.76m		FRONT & REAR PLANTBEDS
Lighting	8.0			PATHWAY FLOODLIGHTS ALONG EAST & WEST FACADES

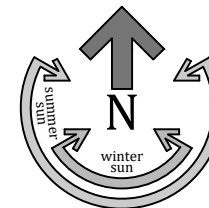

Site Coverage: 341.07 m2
 (House/Porch - 260.65 m2)
 (Garage/Garbage/ 1/2 Visitor Stall - 80.42m2)
 Site Area: 720.09 m2
 58.77 %

554 of Bylaw - 40% reduction on landscaping -
 2.0m2 per 1.0m frontage = 2x15.28m (30.56m2) 4.24%

Required Landscaping: 40% - 4.24% = 35.76%
 Actual Landscaping: 41.23%
 Hard Landscaping: 108.01m2 (47.72%)

Less 50% of Visitor stall hard landscaping = 17.56 m2 /2 =
 8.78 m2 New hard landscaping: 99.23 m2 (41.47%)
 New soft landscaping: 140.05 m2 (58.53%)

319, 32nd AVENUE N.E.
 LOT 20 & 21, BLOCK 67, PLAN 2617 AG

TREE INFORMATION CHART						
TREE	Type	Canopy	Height	Diameter	Status	Location
1	GREEN ASH	10.4	9	0.6	TO REMAIN	CITY PROPERTY
2	GREEN ASH	11.1	14	0.5	TO BE REMOVED	CITY PROPERTY
3	GREEN ASH	10.7	12	0.3	TO REMAIN	CITY PROPERTY

NOTE: LANDSCAPED AREAS TO HAVE UNDERGROUND IRRIGATION SYSTEM
 NOTE: ALL PLANT BEDS TO HAVE BLACK MULCH FILL
 NOTE: ALL SODDED AREAS TO BE MADE UP OF DROUGHT RESISTANT SPECIES
 NOTE: MINIMUM TOPSOIL DEPTH TO BE 300mm FOR ALL ABSORBENT LANDSCAPE AREAS
 AND 600mm FOR PLANT BEDS WITH SHRUBS

LANDSCAPING LEGEND	
	SOFT LANDSCAPING - SOD
	SOFT LANDSCAPING - MULCH PLANT BED
	SOFT LANDSCAPING - VEGETATION (TREES & SHRUBS)
	HARD LANDSCAPING - CONCRETE PATHWAYS/APRON
	HARD LANDSCAPING - AMENITY SPACE (PATIO)



LANDSCAPE FLOODLIGHTS
 SCALE: N.T.S.

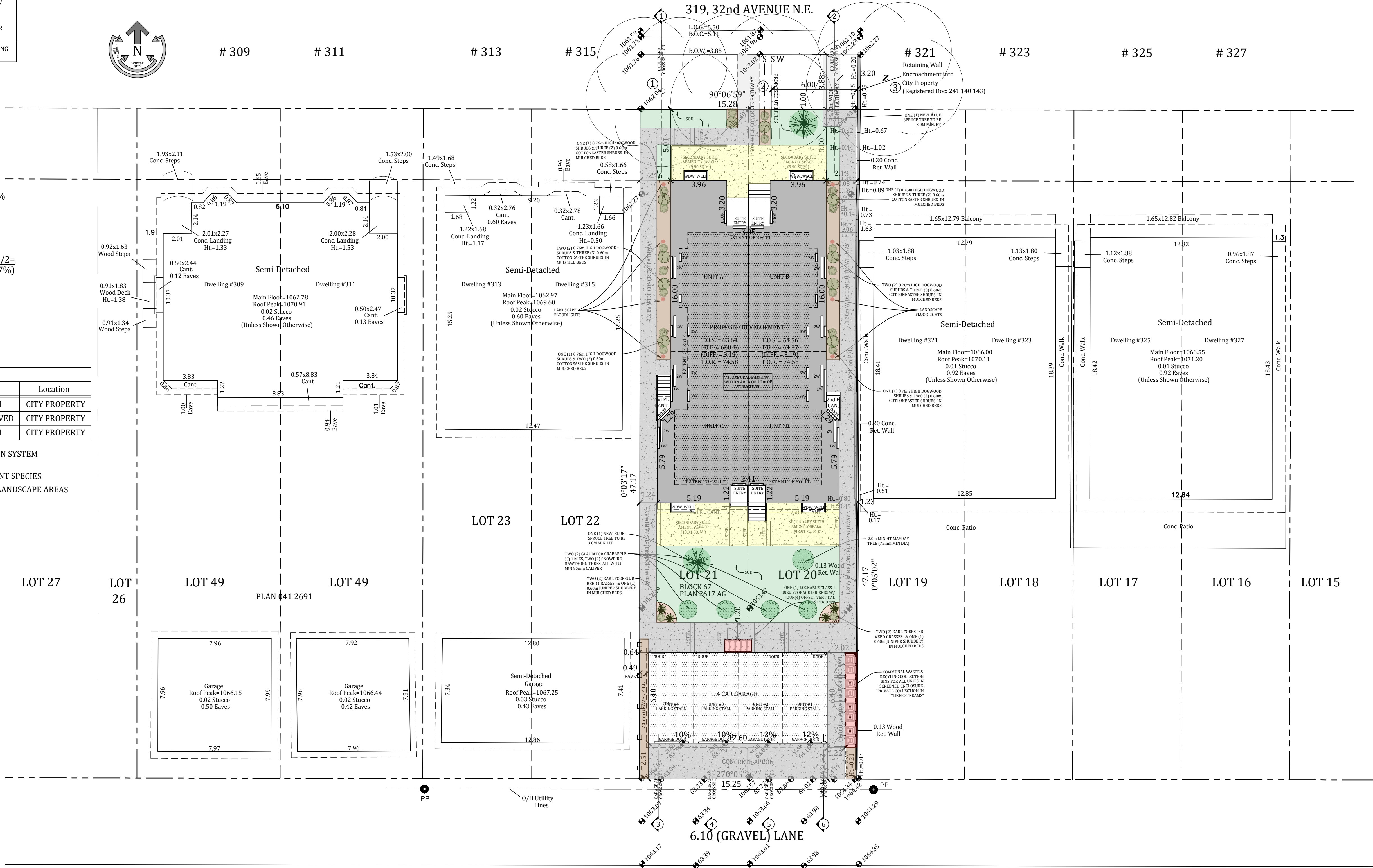

OVERALL LANDSCAPE PLAN
 SCALE: 1:150

AMENDED DRAWINGS
 DP No Date Received
 DP2025-05529 JUN 01 2026
 THESE DRAWINGS REFER TO THE
 ABOVE DEVELOPMENT PERMIT NO.

DEVELOPMENT
 PERMIT
 DECISION
 RENDERED
 ON THIS PLAN



155 ELGIN TERRACE S.E.
 CALGARY, AB T2Z 0G3
 TEL: (403) 399 - 2930

www.designhausstudio.com

Need the Full Plans?
 If you need the full set of plans or need changes, call 403.399.2930 or email info@designhausstudio.com for details.

Digital Plans
 A PDF version of this plan is available. Call 403.399.2930 or email info@designhausstudio.com for copies.

Copyright
 Designhaus Studio Inc. reserves the rights to these documents and to all designs contained herein. No copies or alterations are to be made without expressed written permission from the designer. All plans sold by Designhaus Studio Inc. are protected under copyright law.

Liability Disclaimer
 Placement of the residence on the site plan is based on owners desired location and governing authority's regulations. Every property has inherent risks due to location, acts of God, etc. which may cause damage to structures built on said property and bodily injury and/or death to the occupants of said structures. Designhaus Studio Inc. does not in any way guarantee the suitability or any area for construction or habitation, and will not be held liable for damages based on the location of said structure. General Contractor to verify all field conditions and code requirements, insure compliance of proposed structure with said conditions, verify all dimensions & techniques in construction documents, and notify Designhaus Studio Inc. of any discrepancies before construction.

NOVEMBER 26, 2025

OVERALL LANDSCAPE PLAN - FOURPLEX
 319 32nd AVENUE N.E.
 SITE PLAN & STREETScape

Index of pages

A1	Site plan
A2	Landscape plans
A3	Main floor plan
A4	Upper floor plan
A5	Third floor plan
A6	Lower floor plan
A7	North & West elevations
A8	South & East elevations
A9	Structural Cross Sections
A10	Construction Details

A2

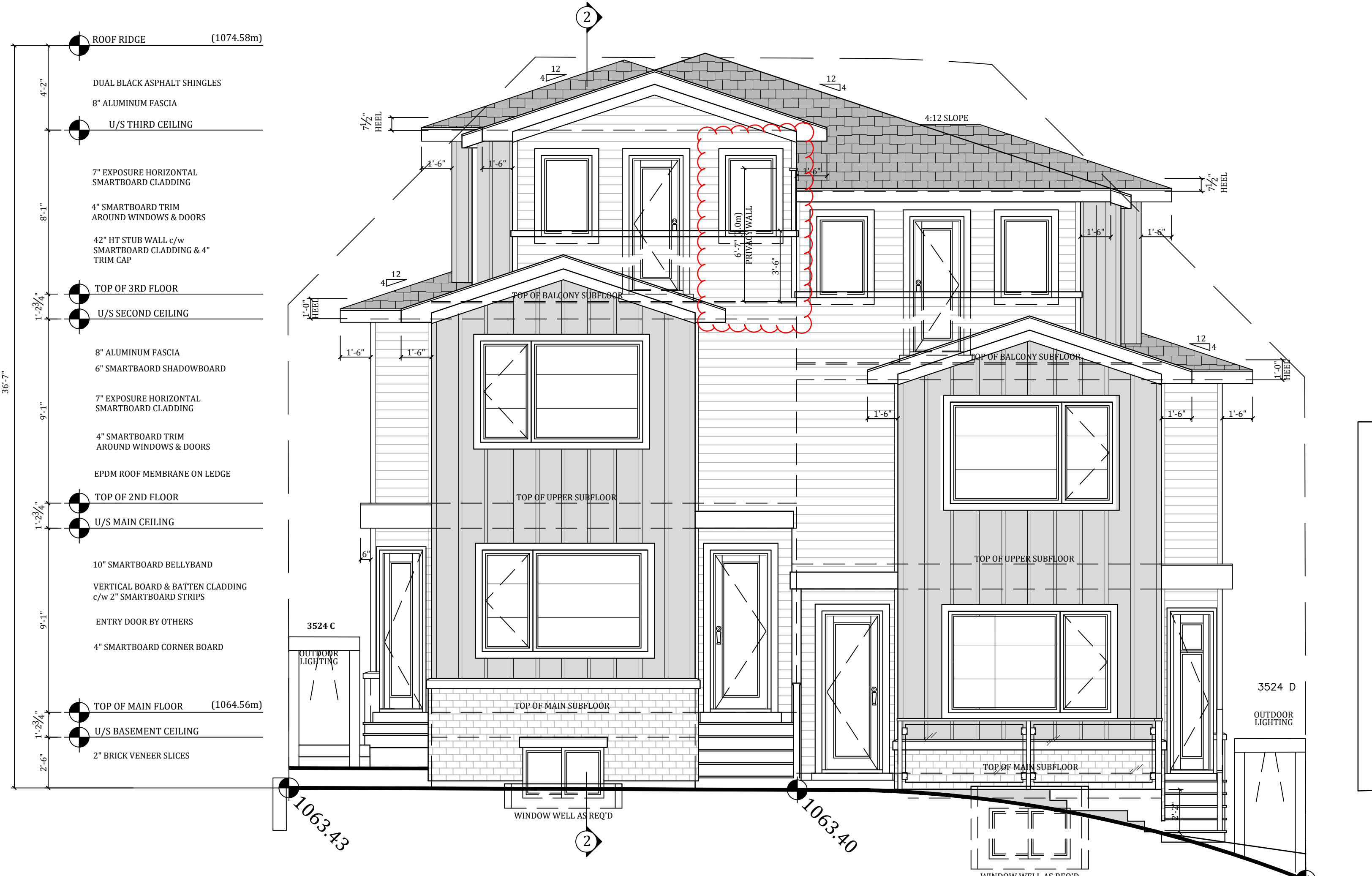

NORTH ELEVATION
SCALE: 1/4" = 1'-0"

AMENDED DRAWINGS
DP No DP2025-05529 Date Received JUN 01 2026
THESE DRAWINGS REFER TO THE ABOVE DEVELOPMENT PERMIT NO.

DEVELOPMENT PERMIT DECISION RENDERED ON THIS PLAN

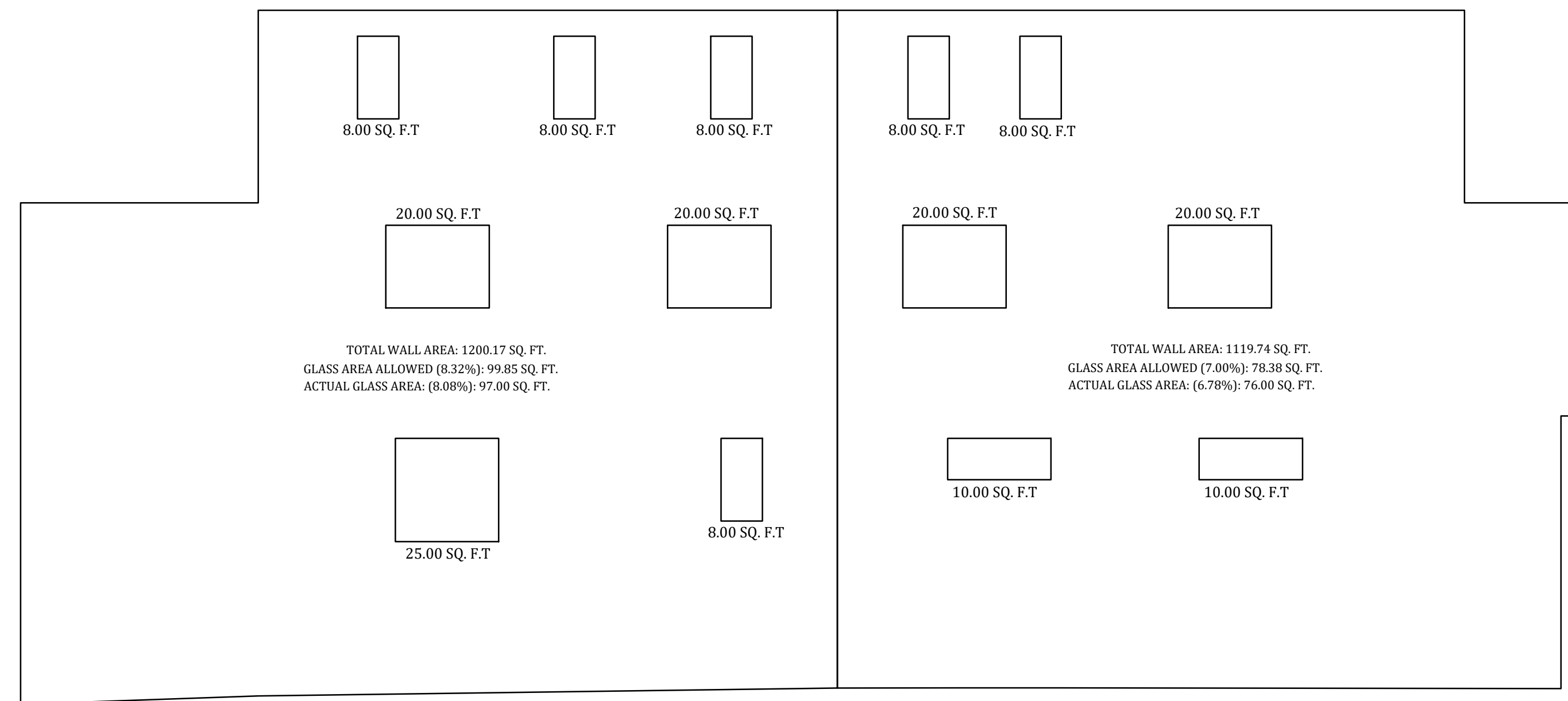

GLASS COVERAGE
SCALE: 1/8" = 1'-0"

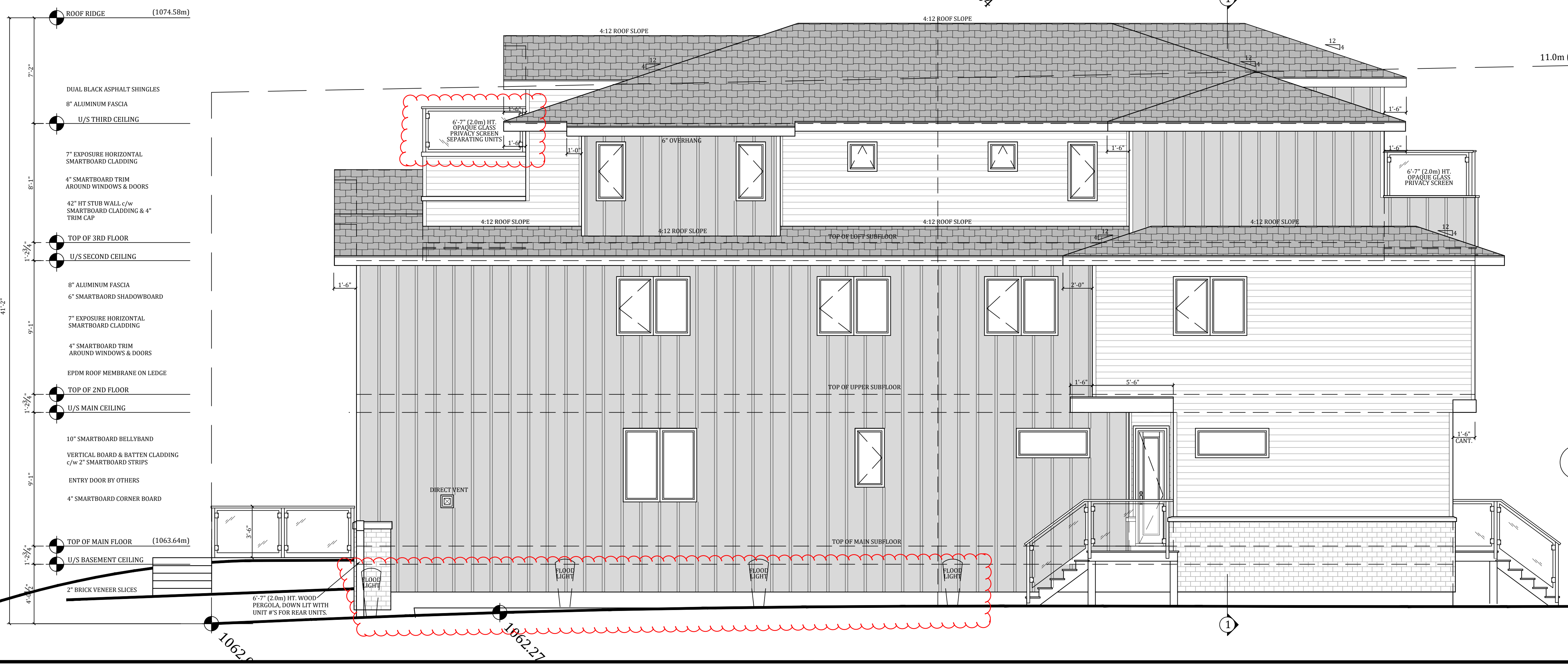

WEST ELEVATION
SCALE: 1/4" = 1'-0"



155 ELGIN TERRACE S.E.
CALGARY, AB T2Z 0G3
TEL: (403) 399-2930

www.designhausstudio.com

Need the Full Plans?
If you need the full set of plans or need changes, call 403.399.2930 or email info@designhausstudio.com for details.

Digital Plans
A PDF version of this plan is available. Call 403.399.2930 or email info@designhausstudio.com for copies.

Copyright
Designhaus Studio Inc. reserves the rights to these documents and to all designs contained herein. No copies or alterations are to be made without expressed written permission from the designer. All plans sold by Designhaus Studio Inc. are protected under copyright law.

Liability Disclaimer
Placement of the residence on the site plan is based on owners desired location and governing authority's regulations. Every property has inherent risks due to location, acts of God, etc., which may cause damage to structures built on said property and bodily injury and/or death to the occupants of said structures. Designhaus Studio Inc. does not in any way guarantee the suitability or any area for construction or habitation, and will not be held liable for damages based on the location of said structure. General Contractor to verify all field conditions and code requirements, insure compliance of proposed structure with said conditions, verify all dimensions & techniques in construction documents, and notify Designhaus Studio Inc. of any discrepancies before construction.

APRIL 29, 2026

NORTH & WEST ELEVATIONS - FOURPLEX
319 32nd AVENUE N.E.

Index of pages

- A1 Site plan
- A2 Landscape plans
- A3 Main floor plan
- A4 Upper floor plan
- A5 Third floor plan
- A6 Lower floor plan
- A7 North & West elevations
- A8 South & East elevations
- A9 Structural Cross Sections
- A10 Construction Details

A7

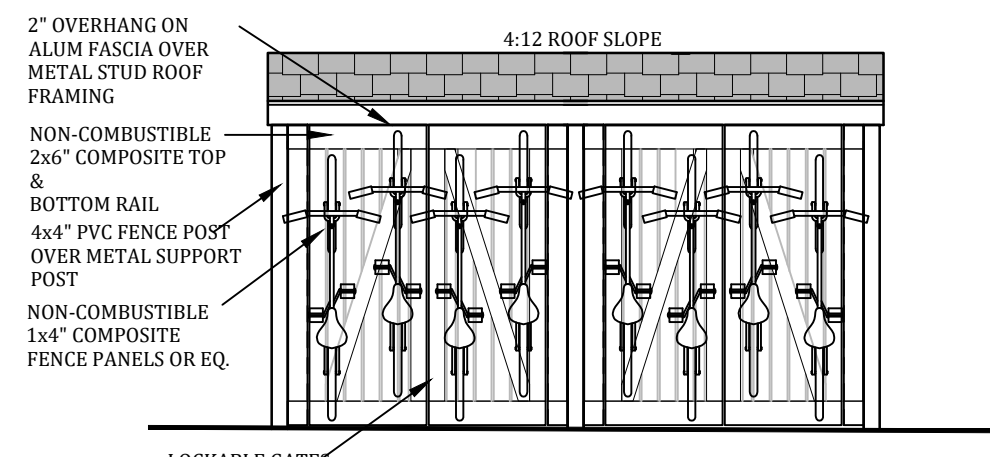
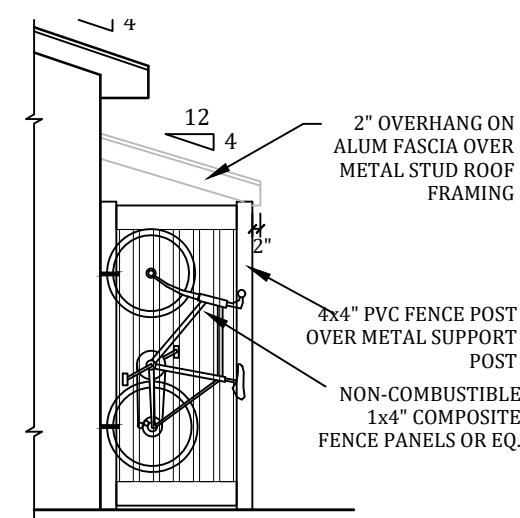
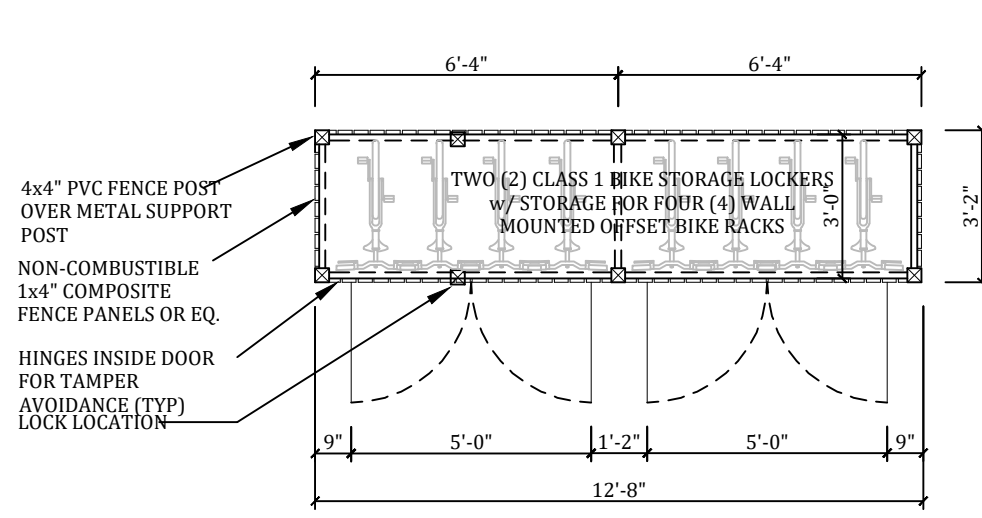

GARBAGE BIN ENCLOSURE PLANS & ELEVATIONS
SCALE: 1/4" = 1'-0"

2 STRUCTURAL CROSS SECTION
SCALE: 1/4" = 1'-0"

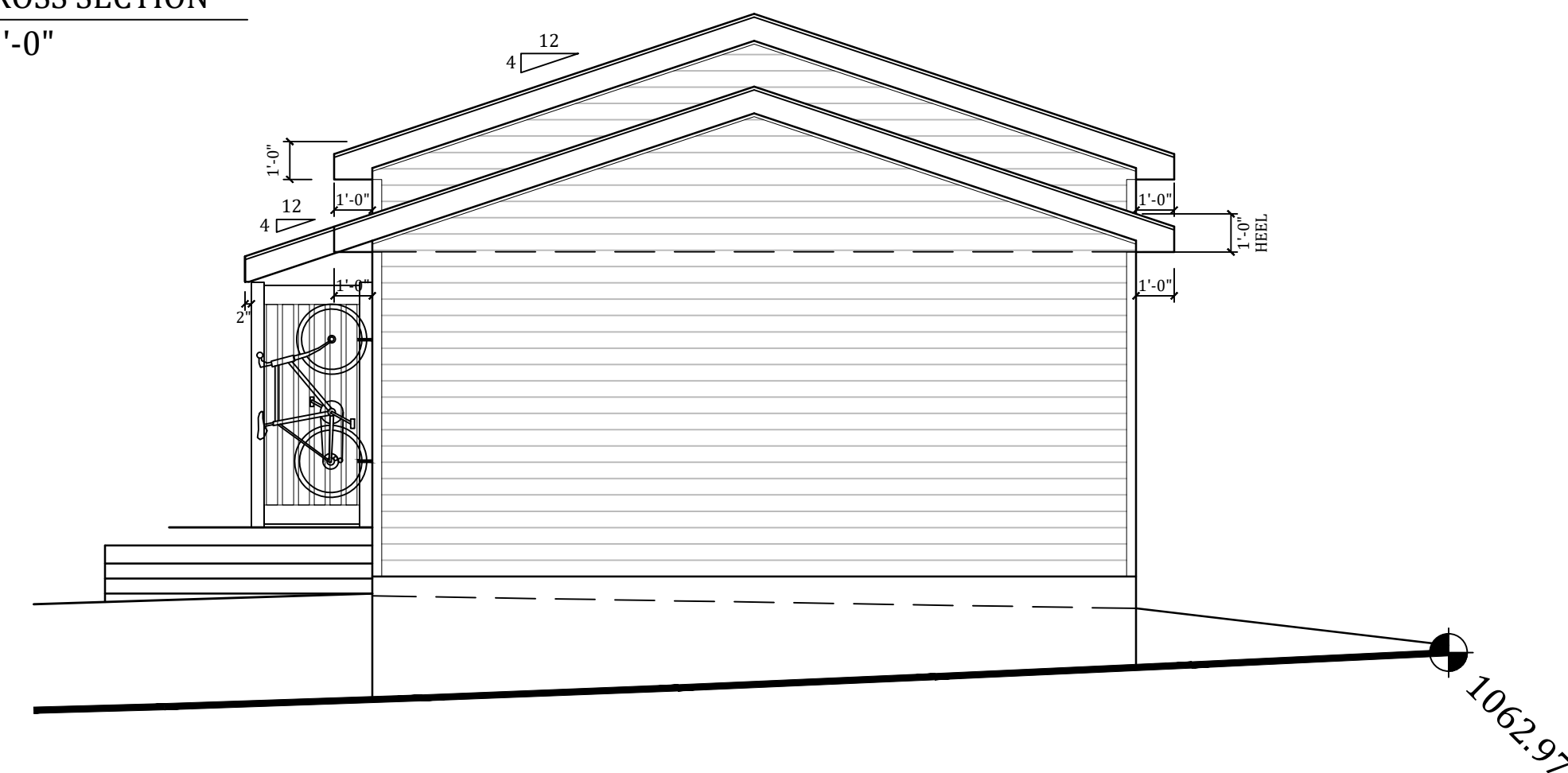

WEST ELEVATION
SCALE: 1/4" = 1'-0"

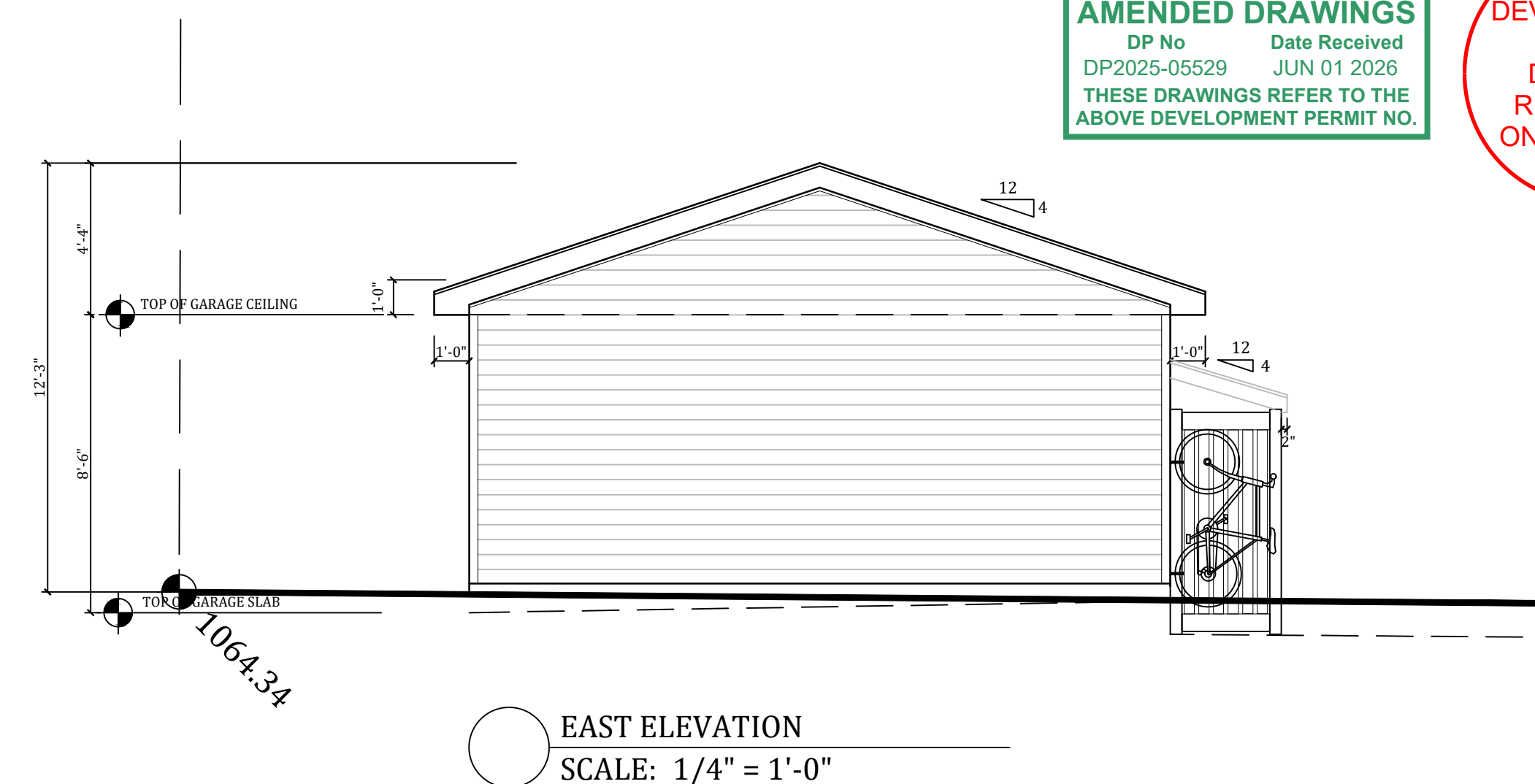

EAST ELEVATION
SCALE: 1/4" = 1'-0"

- 1 - 4" POURED CONCRETE SLAB OVER REINFORCED WITH 6X6X6/6 WELDED WIRE MESH GRID SLOPED 4" TO FRONT c/w THICKENED SLAB EDGE AS PER ENG. SPEC 5" GRANULAR 'A' STONE (COMPACTED)
- 2 COMPLIES WITH SPV-003 FOR EXTERIOR WALLS AS SHOWN (1hr F.R.R.)
CEMENTITIOUS STUCCO CLADDING ON WIRE MESH BACKING ON BLDG PAPER 5/8" DENSIELD SHEATHING (45 min) 2x4" STUDS @ 16" O/C, 2x6" STUDS ON GARAGE DR WALL R12+ MINERAL FIBRE INSULATION 6 MIL VAPOUR BARRIER 5/8" TYPE X GYPSUM WALL BOARD
- 3 COMPLIES WITH SPV-003
- ASPHALT SHINGLES ON # 15 FELT BUILDING PAPER 3/8" OSB OR EQ SHEATHING W/ 'H' CLIPS APPROVED WOOD TRUSSES @ 24" O/C R-40 INSULATION 6 MIL VAPOUR BARRIER 5/8" TYPE X GYPSUM CEILING BOARD
- 4 COMPLIES WITH SPV-003 FOR INTERIOR WALL SEPARATING GARAGE BAYS (1hr F.R.R.)
5/8" TYPE X GYPSUM WALL BOARD 2x6" STUDS @ 16" O/C 5/8" TYPE X GYPSUM WALL BOARD

AMENDED DRAWINGS
DP No Date Received
DP2025-05529 JUN 01 2026
THESE DRAWINGS REFER TO THE ABOVE DEVELOPMENT PERMIT NO.

DEVELOPMENT PERMIT DECISION RENDERED ON THIS PLAN



155 ELGIN TERRACE S.E.
CALGARY, AB T2Z 0G3
TEL: (403) 399 - 2930

www.designhausstudio.com

Need the Full Plans?
If you need the full set of plans or need changes, call 403.399.2930 or email info@designhausstudio.com for details.

Digital Plans
A PDF version of this plan is available. Call 403.399.2930 or email info@designhausstudio.com for copies.

Copyright
Designhaus Studio Inc. reserves the rights to these documents and to all designs contained herein. No copies or alterations are to be made without expressed written permission from the designer. All plans sold by Designhaus Studio Inc. are protected under copyright law.

Liability Disclaimer
Placement of the residence on the site plan is based on owners desired location and governing authority's regulations. Every property has inherent risks due to location, acts of God, etc., which may cause damage to structures built on said property and bodily injury and/or death to the occupants of said structures. Designhaus Studio Inc. does not in any way guarantee the suitability or any area for construction or habitation, and will not be held liable for damages based on the location of said structure. General Contractor to verify all field conditions and code requirements, insure compliance of proposed structure with said conditions, verify all dimensions & techniques in construction documents, and notify Designhaus Studio Inc. of any discrepancies before construction.

APRIL 29, 2026

GARAGE & GARBAGE ENCLOSURE PLANS
319 32nd AVENUE N.E.

Index of pages

- A1 Site plan
- A2 Landscape plans
- A3 Main floor plan
- A4 Upper floor plan
- A5 Third floor plan
- A6 Lower floor plan
- A7 North & West elevations
- A8 South & East elevations
- A9 Structural Cross Sections
- A10 Construction Details

A11